

Product availability : Stock - Normally stocked in distribution facility



Price\* : 3110.75 USD



## Main

Range of product	Modicon Quantum automation platform
Product or component type	Input/Output analog module
Type of filter	Single pole low pass - 3 dB at 21 Hz +/- 20 % input circuit

## Complementary

I/O modularity	6 channels
Addressing requirement	5 input words 2 output words
Analogue input number	4
Analogue input type	Bipolar current +/- 20 mA 15 bits DC Bipolar voltage +/- 10 V 16 bits DC Bipolar voltage +/- 5 V 15 bits DC Unipolar current 0...20 mA 15 bits DC Unipolar offset current 4...20 mA 14 bits DC Unipolar offset voltage 1...5 V 14 bits DC Unipolar voltage 0...10 V 16 bits DC Unipolar voltage 0...5 V 15 bits DC
Absolute maximum input	+/- 25 mA current +/- 50 V voltage
Input impedance	> 10 MOhm voltage > 250 Ohm current
Offset	+/- 0.0014 % of full scale maximum/°C 0...60 °C input circuit
Gain shift	+/- 0.002 of full scale maximum 0...60 °C input circuit
Common mode rejection	> 80 dB 50/60 Hz input circuit
Analogue output number	2
Analogue output range	4...20 mA
Analogue output resolution	12 bits
Loop voltage	0...60 V DC with external resistance output circuit 7...30 V DC output circuit

Disclaimer: This documentation is not intended as a substitute for and is not to be used for determining suitability or reliability of these products for specific user applications

Voltage drop	30 V DC 20 mA
Setting time	900 µs to +/- 0.1 % of the final value output circuit
External power requirement	7...30 V output circuit
Absolute accuracy error	+/- 0.03 % at 77 °F (25 °C) input circuit +/- 0.05 % of full scale maximum at 77 °F (25 °C) input circuit +/- 0.20 % of full scale at 77 °F (25 °C) output circuit +/- 0.004 % of full scale at 32...140 °F (0...60 °C) output circuit +/- 0.007 %/°C of full scale maximum at 32...140 °F (0...60 °C) output circuit
Linearity	2.4 % over and under range voltage 2.4 % over range, and - 9.6 % under range current Monotonic +/- 1 LSB input Monotonic +/- 1 LSB output
Update time	15 ms output circuit 320 ms input circuit
Fault type	Open circuit input/output circuit Overtaking scale (unipolar) input circuit Status byte output circuit
Isolation between channels	500 V AC for 1 minute 750 V DC for 1 minute
Isolation between channels and bus	500 V AC for 1 minute 750 V DC for 1 minute
Isolation between input channel and output channel	500 V for 1 minute 750 V for 1 minute
Marking	CE
Local signalling	1 LED green bus communication is present (Active) 1 LED red external fault 6 LEDs green channel is turned on 6 LEDs red channel fault
Bus current requirement	350 mA
Module format	Standard
Product weight	0.66 lb(US) (0.3 kg)

## Environment

Product certifications	FM Class 1 Division 2 C-Tick.1
Standards	UL 508 CSA C22.2 No 142
Resistance to electromagnetic fields	9.14 V/yd (10 V/m) 80...2000 MHz conforming to IEC 801-3
Ambient air temperature for operation	32...140 °F (0...60 °C)
Ambient air temperature for storage	-40...185 °F (-40...85 °C)
Relative humidity	95 % without condensation
Operating altitude	<= 16404.2 ft (5000 m)

## Ordering and shipping details

Category	18155 - QUANTUM I/O & POWER SUPPLIES
Discount Schedule	PC21
GTIN	00785901013846
Nbr. of units in pkg.	1
Package weight(Lbs)	1.02
Returnability	Y
Country of origin	FR

## Offer Sustainability

Sustainable offer status	Green Premium product
RoHS (date code: YYWW)	Compliant - since 0842 - Schneider Electric declaration of conformity <a href="#">Schneider Electric declaration of conformity</a>
REACH	Reference not containing SVHC above the threshold

Reference not containing SVHC above the threshold

---

Product environmental profile	Available
Product end of life instructions	Available

---

### Contractual warranty

---

Warranty period	18 months
-----------------	-----------

---

Racks for Modules Mounting

Dimensions of Modules and Racks

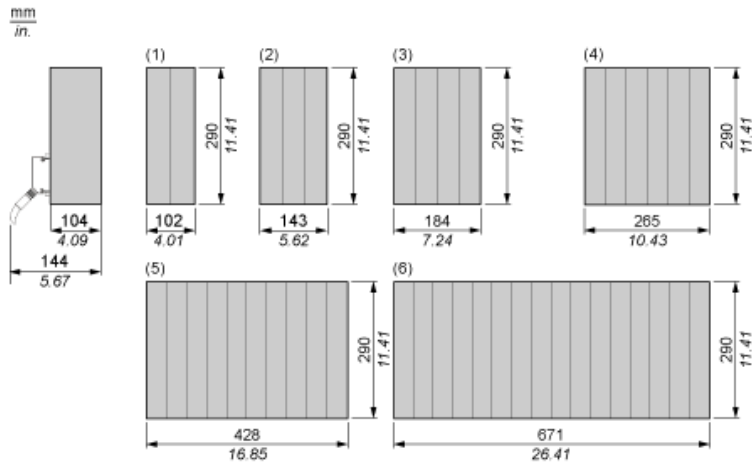

- (1) 2 slots
- (2) 3 slots
- (3) 4 slots
- (4) 6 slots
- (5) 10 slots
- (6) 16 slots

Analog Input/Output Module

Wiring Diagram

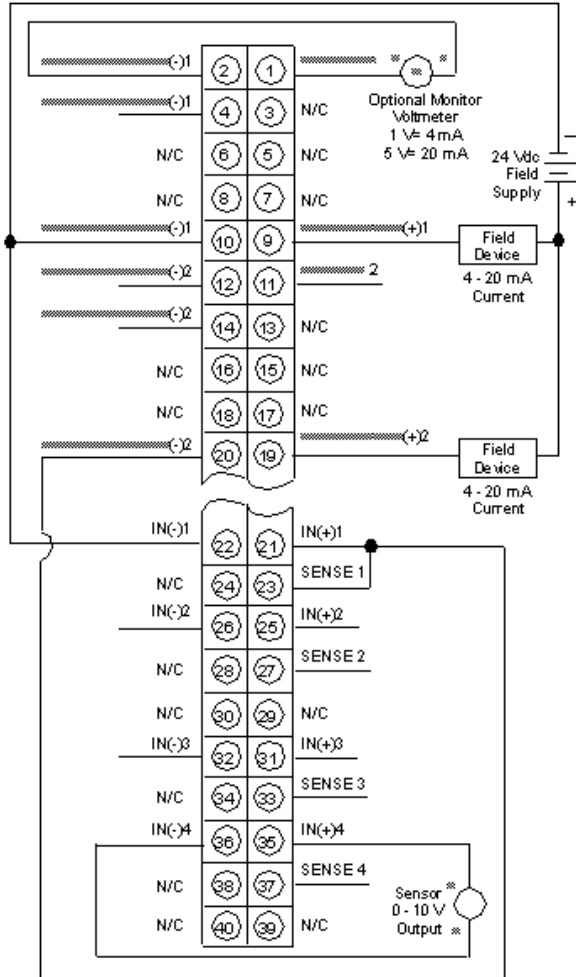

N/C Not Connected

- Jumpers are required between IN (+) and SENSE terminals for all current input ranges.
- Pins 1 ... 20 are outputs.  
Pins 21 ... 40 are inputs.
- For Inputs, the maximum channel to channel working voltage cannot exceed 30 Vdc.