

Product availability : Stock - Normally stocked in distribution facility



Price* : 3926.10 USD



Main

Range of product	Modicon Quantum automation platform
Product or component type	High-speed counter module
Number of channels	2

Complementary

Addressing requirement	6 output words 6 input words
Data format	2147483647 dec 32 bits 65535 dec 16 bits
Counting input type	Incremental or quadrature
Counting frequency	500000 Hz
Discrete input voltage	< 30 V
Operating mode	Incremental or quadrature discrete input
Input resistance	10 kOhm discrete input
Operating threshold	0 V single ended mode 12 V DC at state on >= 1.8 V differential mode 0...11 V single ended mode 24 V DC at state off 0...2 V single ended mode 5 V DC at state on 13...24 V single ended mode 24 V DC at state on 2...7 V single ended mode 12 V DC at state off 3.5...5 V single ended mode 5 V DC at state off
Discrete output number	4
Discrete output type	Field Effect Transistor (FET)
Discrete output voltage	0 V switch off DC 0.4 V switch on DC
Load current	0.5 A
Leakage current	<= 0.4 mA state off
Voltage drop	0.4 V state on

Disclaimer: This documentation is not intended as a substitute for and is not to be used for determining suitability or reliability of these products for specific user applications

Protection type	36 V transorb discrete output
Isolation between channels and bus	1780 Vrms for 60 s
Fault type	Loss of output field power
Output short-circuit protection	Blown fuse 2.5 A
Power dissipation	4 + (0.4 x total module load current)
Bus current requirement	650 mA
External power requirement	19.2...30 V
Rack type	Local Distributed Remote
Local signalling	2 LEDs channel status
Marking	CE
Current consumption	<= 1050 mA 24 V DC external power supply
Module format	Standard

Environment

Resistance to electrostatic discharge	4 kV contact conforming to IEC 801-2 8 kV on air conforming to IEC 801-2
Resistance to electromagnetic fields	9.14 V/yd (10 V/m) 80...1000 MHz conforming to IEC 801-3
Ambient air temperature for operation	32...140 °F (0...60 °C)
Ambient air temperature for storage	-40...185 °F (-40...85 °C)
Relative humidity	95 % without condensation
Operating altitude	<= 16404.2 ft (5000 m)
Standards	UL 508
Product certifications	CSA No 142 C-Tick.1 FM Class 1 Division 2 UL

Ordering and shipping details

Category	18155 - QUANTUM I/O & POWER SUPPLIES
Discount Schedule	PC21
GTIN	00785901794707
Nbr. of units in pkg.	1
Package weight(Lbs)	0.9899999999999999
Returnability	Y
Country of origin	FR

Offer Sustainability

Sustainable offer status	Green Premium product
RoHS (date code: YYWW)	Compliant - since 0901 - Schneider Electric declaration of conformity Schneider Electric declaration of conformity
REACH	Reference not containing SVHC above the threshold Reference not containing SVHC above the threshold
Product environmental profile	Available
Product end of life instructions	Available

Contractual warranty

Warranty period	18 months
-----------------	-----------

Racks for Modules Mounting

Dimensions of Modules and Racks

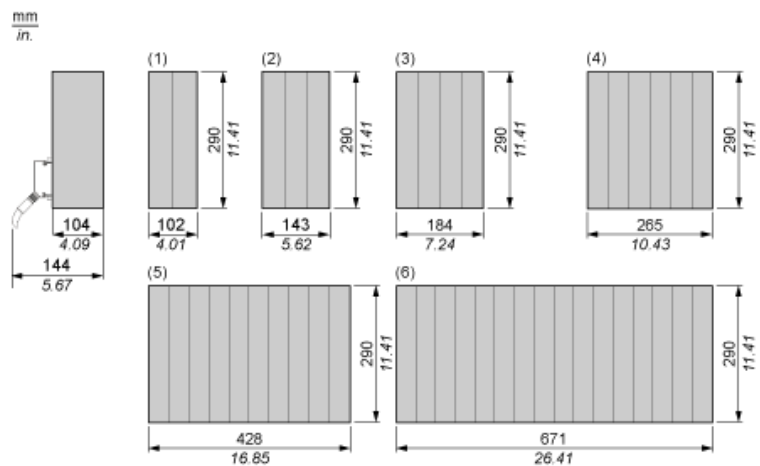

- (1) 2 slots
- (2) 3 slots
- (3) 4 slots
- (4) 6 slots
- (5) 10 slots
- (6) 16 slots

Two-Channel High Speed Counter Module

Wiring Diagram for a Single Ended Pulse Encoder

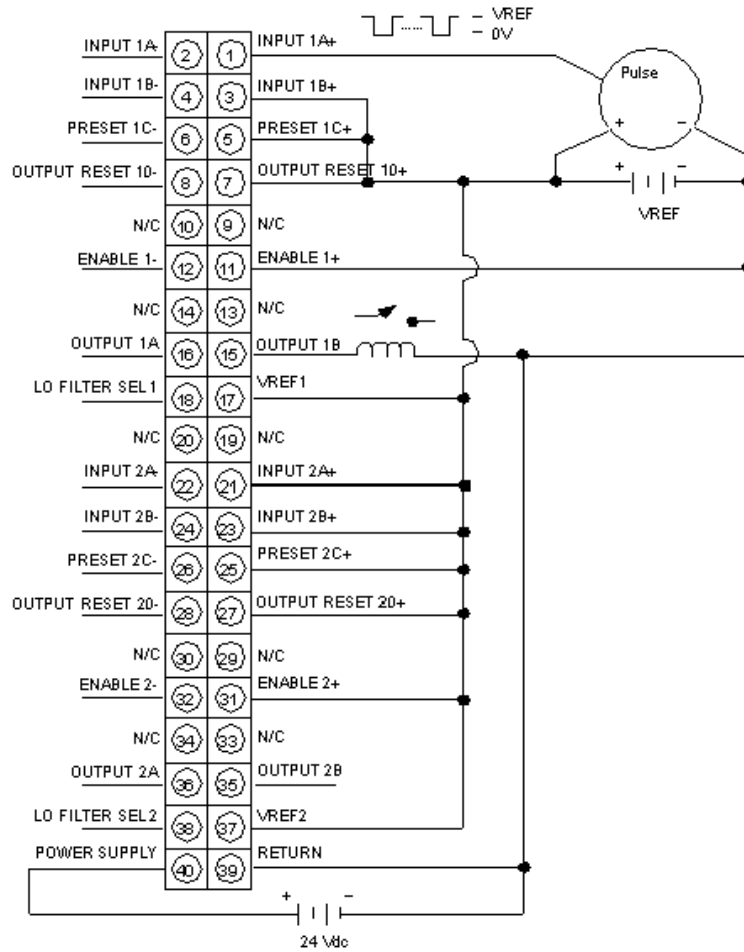

N/C Not Connected

Refer to the user guide for differential pulse encoder input and single ended/differential quadrature encoder input wiring diagrams.