

# Operating Instructions

Capacitive high temperature probe for level detection

## VEGACAP 67

Contactless electronic switch



Document ID: 31314



**VEGA**

# Contents

<b>1</b>	<b>About this document</b>	
1.1	Function .....	4
1.2	Target group .....	4
1.3	Symbols used.....	4
<b>2</b>	<b>For your safety</b>	
2.1	Authorised personnel .....	5
2.2	Appropriate use.....	5
2.3	Warning about incorrect use.....	5
2.4	General safety instructions .....	5
2.5	Safety label on the instrument .....	6
2.6	EU conformity.....	6
2.7	Installation and operation in the USA and Canada .....	6
2.8	Safety instructions for Ex areas .....	6
2.9	Environmental instructions .....	6
<b>3</b>	<b>Product description</b>	
3.1	Configuration.....	7
3.2	Principle of operation.....	9
3.3	Adjustment .....	10
3.4	Packaging, transport and storage.....	10
3.5	Accessories and replacement parts .....	11
<b>4</b>	<b>Mounting</b>	
4.1	General instructions .....	12
4.2	Mounting instructions .....	13
<b>5</b>	<b>Connecting to power supply</b>	
5.1	Preparing the connection .....	17
5.2	Connection procedure.....	17
5.3	Wiring plan, single chamber housing.....	18
<b>6</b>	<b>Setup</b>	
6.1	General information.....	21
6.2	Adjustment elements.....	21
6.3	Function table.....	23
<b>7</b>	<b>Maintenance and fault rectification</b>	
7.1	Maintenance .....	24
7.2	Rectify faults.....	24
7.3	Exchange of the electronics module.....	25
7.4	Shortening of the probe .....	27
7.5	How to proceed if a repair is necessary.....	27
<b>8</b>	<b>Dismount</b>	
8.1	Dismounting steps.....	29
8.2	Disposal .....	29
<b>9</b>	<b>Supplement</b>	
9.1	Technical data .....	30
9.2	Dimensions .....	33
9.3	Industrial property rights.....	35
9.4	Trademark .....	35

### Supplementary documentation



#### Information:

Supplementary documents appropriate to the ordered version come with the delivery. You can find them listed in chapter "*Product description*".

### Instructions manuals for accessories and replacement parts



#### Tip:

To ensure reliable setup and operation of your VEGACAP 67, we offer accessories and replacement parts. The corresponding documentations are:

- 30174 - Electronics module VEGACAP series 60
- 34296 - Protective cover
- 31088 - Flanges according to DIN-EN-ASME-JIS-GOST

Editing status: 2017-04-06

# 1 About this document

## 1.1 Function

This operating instructions manual provides all the information you need for mounting, connection and setup of the instrument. Furthermore there are important instructions for maintenance, fault rectification, the exchange of parts and the safety of the user. Please read this information before putting the instrument into operation and keep this manual accessible in the immediate vicinity of the device.

## 1.2 Target group

This operating instructions manual is directed to trained specialist personnel. The contents of this manual should be made available to these personnel and put into practice by them.

## 1.3 Symbols used



### Information, tip, note

This symbol indicates helpful additional information.



**Caution:** If this warning is ignored, faults or malfunctions can result.



**Warning:** If this warning is ignored, injury to persons and/or serious damage to the instrument can result.



**Danger:** If this warning is ignored, serious injury to persons and/or destruction of the instrument can result.



### Ex applications

This symbol indicates special instructions for Ex applications.



### SIL applications

This symbol indicates instructions for functional safety which must be taken into account particularly for safety-relevant applications.

- **List**

The dot set in front indicates a list with no implied sequence.

- **Action**

This arrow indicates a single action.

- 1 **Sequence of actions**

Numbers set in front indicate successive steps in a procedure.



### Battery disposal

This symbol indicates special information about the disposal of batteries and accumulators.

## 2 For your safety

### 2.1 Authorised personnel

All operations described in this operating instructions manual must be carried out only by trained specialist personnel authorised by the plant operator.

During work on and with the device the required personal protective equipment must always be worn.

### 2.2 Appropriate use

The VEGACAP 67 is a sensor for point level detection.

You can find detailed information about the area of application in chapter "*Product description*".

Operational reliability is ensured only if the instrument is properly used according to the specifications in the operating instructions manual as well as possible supplementary instructions.

For safety and warranty reasons, any invasive work on the device beyond that described in the operating instructions manual may be carried out only by personnel authorised by the manufacturer. Arbitrary conversions or modifications are explicitly forbidden.

### 2.3 Warning about incorrect use

Inappropriate or incorrect use of the instrument can give rise to application-specific hazards, e.g. vessel overfill or damage to system components through incorrect mounting or adjustment. Thus damage to property, to persons or environmental contamination can be caused. Also the protective characteristics of the instrument can be influenced.

### 2.4 General safety instructions

This is a state-of-the-art instrument complying with all prevailing regulations and directives. The instrument must only be operated in a technically flawless and reliable condition. The operator is responsible for the trouble-free operation of the instrument. When measuring aggressive or corrosive media where a malfunction of the instrument can cause a danger, the operator has to convince himself on the correct function of the instrument by taking suitable measures.

During the entire duration of use, the user is obliged to determine the compliance of the necessary occupational safety measures with the current valid rules and regulations and also take note of new regulations.

The safety instructions in this operating instructions manual, the national installation standards as well as the valid safety regulations and accident prevention rules must be observed by the user.

For safety and warranty reasons, any invasive work on the device beyond that described in the operating instructions manual may be carried out only by personnel authorised by the manufacturer. Arbitrary conversions or modifications are explicitly forbidden. For safety

reasons, only the accessory specified by the manufacturer must be used.

To avoid any danger, the safety approval markings and safety tips on the device must also be observed and their meaning looked up in this operating instructions manual.

## 2.5 Safety label on the instrument

The safety approval markings and safety tips on the device must be observed.

## 2.6 EU conformity

The device fulfils the legal requirements of the applicable EU directives. By affixing the CE marking, we confirm successful testing of the product.

You can find the EU conformity declaration on our website under [www.vega.com/downloads](http://www.vega.com/downloads).

## 2.7 Installation and operation in the USA and Canada

This information is only valid for USA and Canada. Hence the following text is only available in the English language.

Installations in the US shall comply with the relevant requirements of the National Electrical Code (ANSI/NFPA 70).

Installations in Canada shall comply with the relevant requirements of the Canadian Electrical Code

## 2.8 Safety instructions for Ex areas

Please note the Ex-specific safety information for installation and operation in Ex areas. These safety instructions are part of the operating instructions manual and come with the Ex-approved instruments.

## 2.9 Environmental instructions

Protection of the environment is one of our most important duties. That is why we have introduced an environment management system with the goal of continuously improving company environmental protection. The environment management system is certified according to DIN EN ISO 14001.

Please help us fulfil this obligation by observing the environmental instructions in this manual:

- Chapter "*Packaging, transport and storage*"
- Chapter "*Disposal*"

## 3 Product description

### 3.1 Configuration

#### Scope of delivery

The scope of delivery encompasses:

- VEGACAP 67 point level switch
- Documentation
  - This operating instructions manual
  - Safety Manual "*Functional safety (SIL)*" (optional)
  - Supplementary instructions manual "*Plug connector for level sensors*" (optional)
  - Ex-specific "*Safety instructions*" (with Ex versions)
  - If necessary, further certificates

#### Constituent parts

The VEGACAP 67 consists of the components:

- Process fitting with probe
- Housing with electronics
- Housing cover, optionally available with display and adjustment module

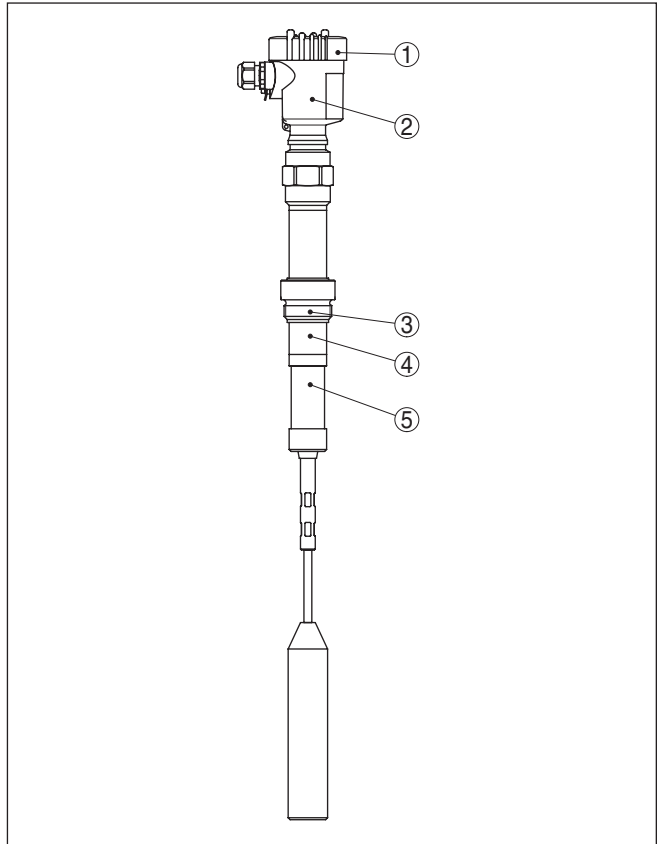

Fig. 1: VEGACAP 67 with plastic housing

- 1 Housing lid
- 2 Housing with electronics
- 3 Process fitting
- 4 Supporting tube
- 5 Ceramic insulator

**Type label**

The type label contains the most important data for identification and use of the instrument:

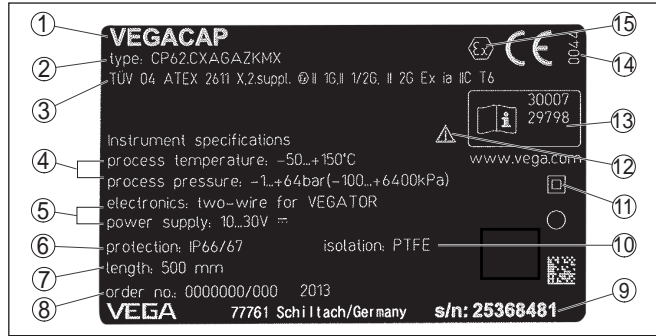

Fig. 2: Layout of the type label (example)

- 1 Instrument type
- 2 Product code
- 3 Approvals
- 4 Process and ambient temperature, process pressure
- 5 Power supply and signal output, electronics
- 6 Protection rating
- 7 Probe length
- 8 Order number
- 9 Serial number of the instrument
- 10 Material, wetted parts
- 11 Symbol of the device protection class
- 12 Reminder to observe the instrument documentation
- 13 ID numbers, instrument documentation
- 14 Notified authority for CE marking
- 15 Approval directives

With the serial number, you can access the delivery data of the instrument via "[www.vega.com](http://www.vega.com)", "VEGA Tools" and "Instrument search". You can find the serial number on the inside of the instrument as well as on the type label on the outside.

### 3.2 Principle of operation

#### Application area

The VEGACAP 67 is a point level sensor for bulk solids. The probe is designed for high temperature applications.

#### Functional principle

Probe, measured product and vessel wall form an electrical capacitor. The capacitance is influenced by three main factors.

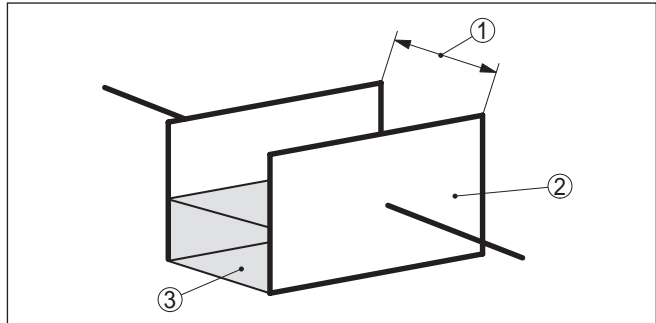

Fig. 3: Functional principle - Plate capacitor

- 1 Distance between the electrode surfaces
- 2 Size of the electrode surfaces
- 3 Type of dielectric between the electrodes

The probe and the vessel wall are the capacitor plates. The measured product is the dielectric. Due to the higher dielectric constant of the product compared to air, the capacitance increases as the probe is gradually covered.

The capacitance change is converted by the electronics module into a switching command.

## Voltage supply

VEGACAP 67 is a compact instrument, i.e. it can be operated without external evaluation system. The integrated electronics evaluates the level signal and outputs a switching signal. With this switching signal, a connected device can be operated directly (e.g. a warning system, a pump etc.).

The data for power supply are specified in chapter "*Technical data*".

## 3.3 Adjustment

The probe can be adapted to the dielectric constant of the product directly on the electronics module.

A switching command can be triggered when the probe is covered or laid bare.

On the electronics module you will find the following display and adjustment elements:

- Signal lamp for indication of the switching condition (green/red)
- Potentiometer for switching point adaptation
- DIL switch for measuring range selection
- DIL switch for mode adjustment

## 3.4 Packaging, transport and storage

### Packaging

Your instrument was protected by packaging during transport. Its capacity to handle normal loads during transport is assured by a test based on ISO 4180.

The packaging of standard instruments consists of environment-friendly, recyclable cardboard. For special versions, PE foam or PE

foil is also used. Dispose of the packaging material via specialised recycling companies.

**Transport**

Transport must be carried out in due consideration of the notes on the transport packaging. Nonobservance of these instructions can cause damage to the device.

**Transport inspection**

The delivery must be checked for completeness and possible transit damage immediately at receipt. Ascertained transit damage or concealed defects must be appropriately dealt with.

**Storage**

Up to the time of installation, the packages must be left closed and stored according to the orientation and storage markings on the outside.

Unless otherwise indicated, the packages must be stored only under the following conditions:

- Not in the open
- Dry and dust free
- Not exposed to corrosive media
- Protected against solar radiation
- Avoiding mechanical shock and vibration

**Storage and transport temperature**

- Storage and transport temperature see chapter "*Supplement - Technical data - Ambient conditions*"
- Relative humidity 20 ... 85 %

**Lifting and carrying**

With an instrument weight of more than 18 kg (39.68 lbs) suitable and approved equipment must be used for lifting and carrying.

**3.5 Accessories and replacement parts**

**Protective cover**

The protective cover protects the sensor housing against soiling and intense heat from solar radiation.

You will find additional information in the supplementary instructions manual "*Protective cover*" (Document-ID 34296).

**Flanges**

Screwed flanges are available in different versions according to the following standards: DIN 2501, EN 1092-1, BS 10, ASME B 16.5, JIS B 2210-1984, GOST 12821-80.

You can find additional information in the supplementary instructions manual "*Flanges according to DIN-EN-ASME-JIS*".

## 4 Mounting

### 4.1 General instructions

<b>Suitability for the process conditions</b>	<p>Make sure that all parts of the instrument coming in direct contact with the process, especially the sensor element, process seal and process fitting, are suitable for the existing process conditions, such as process pressure, process temperature as well as the chemical properties of the medium.</p> <p>You can find the specifications in chapter "<i>Technical data</i>" and on the nameplate.</p>
<b>Suitability for the ambient conditions</b>	<p>The instrument is suitable for standard and extended ambient conditions acc. to DIN/EN/IEC/ANSI/ISA/UL/CSA 61010-1.</p>
<b>Switching point</b>	<p>In general, VEGACAP 67 must be mounted vertically. The instrument must be mounted in such a way that the probe is at the height of the requested switching point.</p>
<b>Welding work</b>	<p>Before beginning the welding work, remove the electronics module from the sensor. By doing this, you avoid damage to the electronics through inductive coupling.</p> <p>Ground the probe before welding directly on the rod or cable.</p>
<b>Handling</b>	<p>With threaded versions, the housing must not be used to screw in the instrument! Applying tightening forces on the housing can damage its internal parts.</p> <p>Use the hexagon for screwing in.</p>
<b>Moisture</b>	<p>Use the recommended cables (see chapter "<i>Connecting to power supply</i>") and tighten the cable gland.</p> <p>You can give your instrument additional protection against moisture penetration by leading the connection cable downward in front of the cable entry. Rain and condensation water can thus drain off. This applies mainly to outdoor mounting as well as installation in areas where high humidity is expected (e.g. through cleaning processes) or on cooled or heated vessels.</p> <p>To maintain the housing protection, make sure that the housing lid is closed during operation and locked, if necessary.</p> <p>Make sure that the degree of contamination specified in chapter "<i>Technical data</i>" meets the existing ambient conditions.</p>

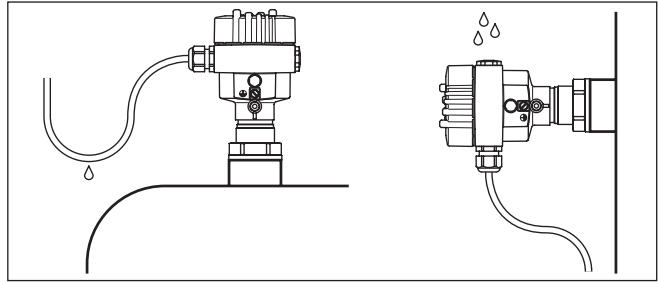

Fig. 4: Measures against moisture ingress

**Pressure/Vacuum**

The process fitting must be sealed if there is gauge or low pressure in the vessel. Before use, check if the seal material is resistant against the measured product and the process temperature.

The max. permissible pressure is specified in chapter "Technical data" or on the type label of the sensor.

**Vessel material**

**Metal vessel**

Make sure that the mechanical connection of the probe to the vessel is electrically conductive to ensure sufficient grounding.

Use conductive seals, such as those made of copper or lead, etc. Insulating measures, such as covering the thread with Teflon tape, can interrupt the necessary electrical connection with metal vessels. For this reason, ground the probe on the vessel or use a conductive seal material.

**Non-conductive vessels**

In non-conductive vessels, e.g. plastic tanks, the second pole of the capacitor must be provided separately.

**Cable entries - NPT thread  
Cable glands**

**Metric threads**

In the case of instrument housings with metric thread, the cable glands are screwed in at the factory. They are sealed with plastic plugs as transport protection.

You have to remove these plugs before electrical connection.

**NPT thread**

In the case of instrument housings with self-sealing NPT threads, it is not possible to have the cable entries screwed in at the factory. The free openings for the cable glands are therefore covered with red dust protection caps as transport protection.

Prior to setup you have to replace these protective caps with approved cable glands or close the openings with suitable blind plugs.

**4.2 Mounting instructions**

**Agitators and fluidization**

Due to the effects of agitators, equipment vibration or similar, the level switch can be subjected to strong lateral forces. For this reason, do not use an overly long electrode for VEGACAP 67, but check if you

can mount a short level switch on the side of the vessel in horizontal position.

### Inflowing medium

If the instrument is mounted in the filling stream, unwanted false measurement signals can be generated. For this reason, mount the instrument at a position in the vessel where no disturbances, e.g. from filling openings, agitators, etc., can occur.

This applies particularly to instrument versions with a longer probe.

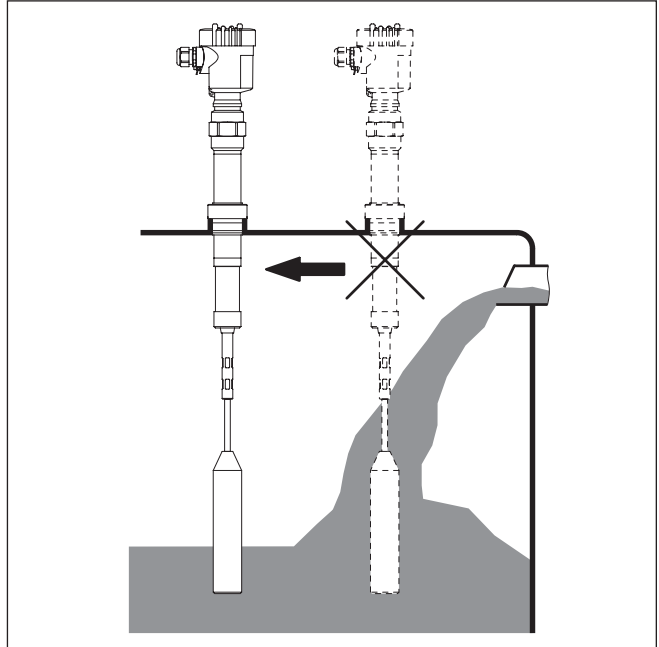

Fig. 5: Inflowing medium

### Mounting socket

The probe should protrude into the vessel to avoid buildup. For that reason, avoid using mounting bosses for flanges and screwed fittings. This applies particularly to use with adhesive products.

### Material cone

In silos with bulk solids, material cones can form which change the switching point. Please keep this in mind when installing the sensor in the vessel. We recommend selecting an installation location where the probe detects the average value of the material cone.

The probe must be mounted in a way that takes the arrangement of the filling and emptying apertures into account.

To compensate measurement errors caused by the material cone in cylindrical vessels, the sensor must be mounted at a distance of  $d/6$  from the vessel wall.

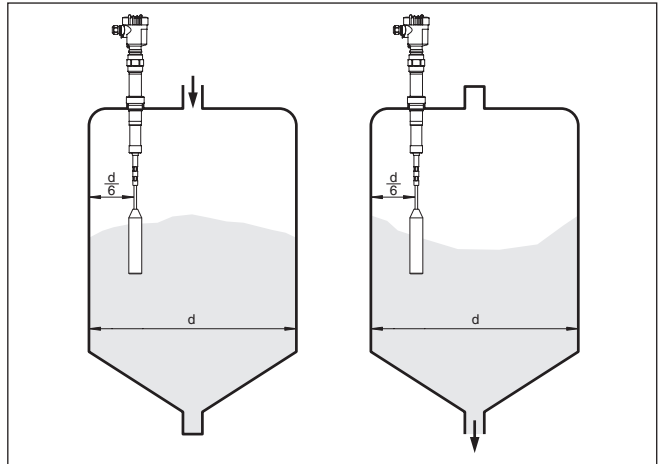

Fig. 6: Filling and emptying centred

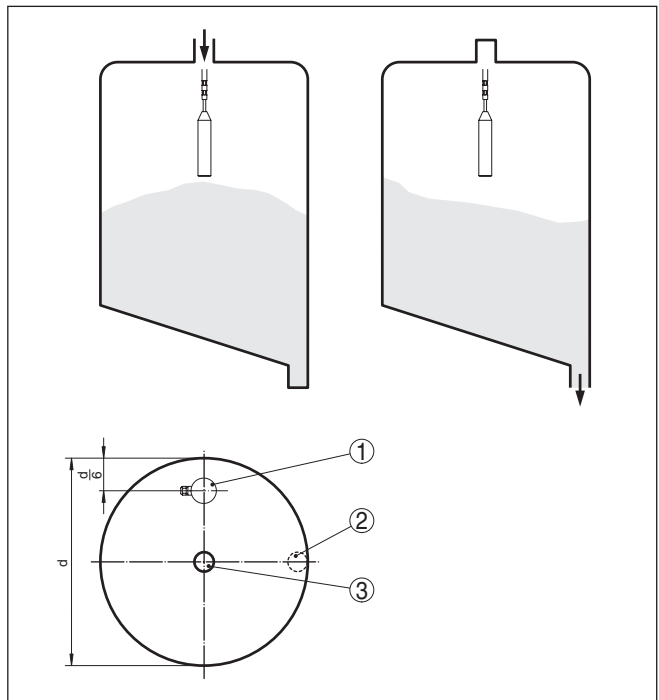

Fig. 7: Filling in the centre, emptying laterally

- 1 VEGACAP 67
- 2 Discharge opening
- 3 Filling opening

**Tensile load**

Make sure that the max. permissible tensile load of the suspension cable is not exceeded. The danger of this happening exists particularly with very heavy solids and large meas. lengths. The max. permissible load is stated in chapter "*Technical data*".

## 5 Connecting to power supply

### 5.1 Preparing the connection

**Note safety instructions** Always keep in mind the following safety instructions:



**Warning:**

Connect only in the complete absence of line voltage.

- The electrical connection must only be carried out by trained personnel authorised by the plant operator.
- Always switch off power supply, before connecting or disconnecting the instrument.



**Note:**

Install a separating facility for the instrument which is easy to access. The separating facility must be marked for the instrument (IEC/EN 61010).

#### Voltage supply

Connect mains voltage according to the connection diagrams. Take note of the general installation regulations. The electronics module CP60C is designed in protection class I. To maintain this protection class, it is absolutely necessary that the ground conductor be connected to the internal ground conductor terminal. Take note of the corresponding installation regulations for Ex applications.

The data for power supply are specified in chapter "*Technical data*".

#### Connection cable

The instrument is connected with standard three-wire cable without screen. If electromagnetic interference is expected which is above the test values of EN 61326 for industrial areas, screened cable should be used.

Make sure that the cable used has the required temperature resistance and fire safety for max. occurring ambient temperature

Use cable with round cross-section. A cable outer diameter of 5 ... 9 mm (0.2 ... 0.35 in) ensures the seal effect of the cable gland. If you are using cable with a different diameter or cross-section, exchange the seal or use a suitable cable gland.

### 5.2 Connection procedure



With Ex instruments, the housing cover may only be opened if there is no explosive atmosphere present.

Proceed as follows:

1. Unscrew the housing lid
2. Loosen compression nut of the cable gland and remove blind plug
3. Remove approx. 10 cm (4 in) of the cable mantle, strip approx. 1 cm (0.4 in) of insulation from the ends of the individual wires
4. Insert the cable into the sensor through the cable entry
5. Lift the opening levers of the terminals with a screwdriver (see following illustration)

6. Insert the wire ends into the open terminals according to the wiring plan
7. Press down the opening levers of the terminals, you will hear the terminal spring closing
8. Check the hold of the wires in the terminals by lightly pulling on them
9. Tighten the compression nut of the cable entry gland. The seal ring must completely encircle the cable
10. If necessary, carry out a fresh adjustment
11. Screw the housing lid back on

The electrical connection is finished.

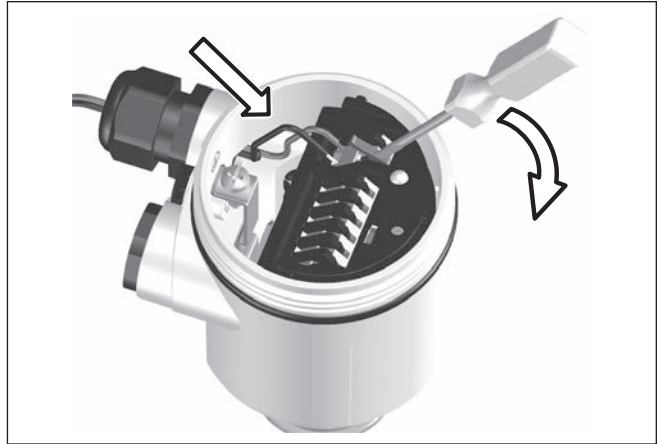

Fig. 8: Connection steps 5 and 6

### 5.3 Wiring plan, single chamber housing

#### Housing overview

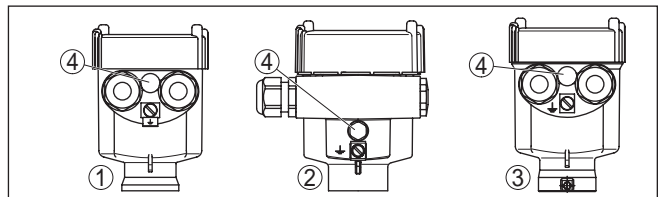

Fig. 9: Material versions, single chamber housing

- 1 Plastic (not with dust-Ex)
- 2 Aluminium
- 3 Stainless steel
- 4 Filter element for air pressure compensation

**Electronics and terminal compartment**

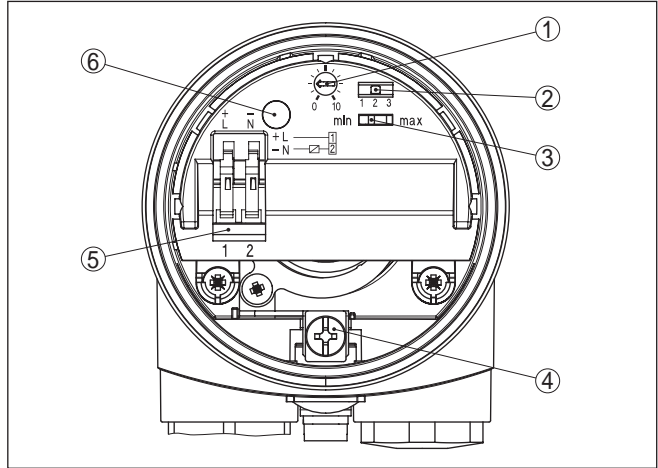

Fig. 10: Electronics and terminal compartment

- 1 Potentiometer for switching point adaptation
- 2 DIL switch for measuring range selection
- 3 DIL switch for mode adjustment
- 4 Ground terminal
- 5 Connection terminals
- 6 Control lamp

**Wiring plan**

We recommend connecting VEGACAP 67 in such a way that the switching circuit is open when there is a level signal, line break or failure (safe state).

The contactless electronic switch is always shown in non-operative condition.



**Warning:**

The instrument must not be operated without an intermediately connected load, because the electronics would be destroyed if connected directly to the mains. It is not suitable for connection to low voltage PLC inputs.

Examples for typical applications:

- Load resistance at 24 V DC: 88 ... 1800 Ω
- Rated power, relay 253 V AC: > 2.5 VA
- Rated power, relay 24 V AC: > 0.5 VA

For direct control of relays, contactors, magnet valves, warning lights, horns etc.

Domestic current is temporarily lowered below 1 mA after switching off the load so that contactors, whose holding current is lower than the constant domestic current of the electronics, are reliably switched off.

When VEGACAP 67 is used as part of an overfill protection system according to WHG, also note the regulations of the general type approval.

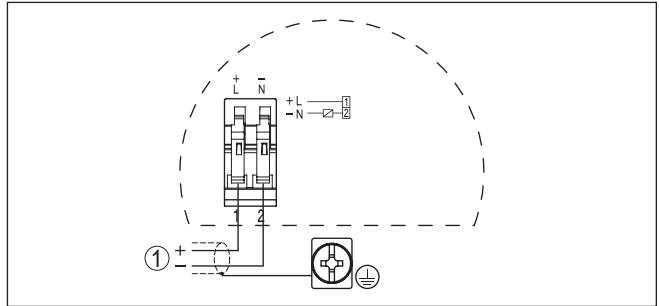

Fig. 11: Wiring plan

1 Voltage supply

## 6 Setup

### 6.1 General information

The figures in brackets refer to the following illustrations.

**Function/Configuration** On the electronics module you will find the following display and adjustment elements:

- Potentiometer for switching point adaptation
- DIL switch for measuring range selection
- DIL switch for mode adjustment - min./max.
- Control lamp



**Note:**

As a rule, always set the mode with the mode switch (3) before starting setup VEGACAP 67. The switching output will change if you set the mode switch (3) afterwards. This could possibly trigger other connected instruments or devices.

### 6.2 Adjustment elements

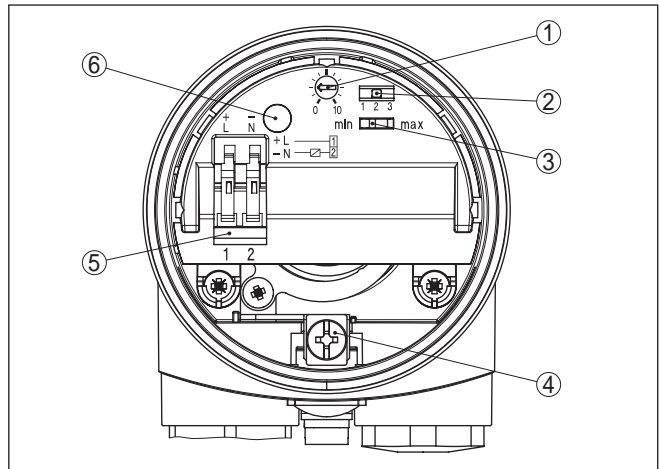

Fig. 12: Oscillator - Contactless electronic switch

- 1 Potentiometer for switching point adaptation
- 2 DIL switch for measuring range selection (with compensation button)
- 3 DIL switch for mode adjustment
- 4 Ground terminal
- 5 Connection terminals
- 6 Control lamp

The switching status of the electronics can be checked with closed housing (only plastic housing), see "Function table".



**Note:**

Screw the housing cover tightly up to the thread stop so that the inspection glass is above the control lamp (LED).

To adjust VEGACAP 67, first of all remove the housing cover.

### Switching point adaptation (1)

You can adapt the switching point to the solid with the potentiometer.

### Measuring range selection switch (2)

With the potentiometer (1) and the measuring range selection switch (2) you can change the sensitivity of the probe to the electrical properties of the product and the conditions in the vessel. This is necessary so that the level switch can also reliably detect products e.g. with very low or very high dielectric figure.

range 1: 0 ... 20 pF

Range 2: 0 ... 85 pF

Range 3: 0 ... 450 pF

### Mode adjustment (3)

With the mode switch (3) you can change the switching status of the output. The required mode can be set according to the function table.

max. - max. detection or overflow protection

min. - min. detection or dry run protection.

We recommend connecting according to the idle current principle (contactless electronic switch is open when the switching point is reached) because the contactless electronic switch takes on the same (safe) state if a failure is detected.

### Signal lamp (6)

Control lamp for indication of the switching status.

- green = switch closed
- red = switch open
- red (flashing) = failure

### Switching point adjustment

The adjustment of the switching point is only possible in installed condition.

The specifications in parenthesis refer to the preceding illustration.

### Mode max. (max. level detection)

#### Vertically mounted probes

1. Set mode switch (3) to mode max.
2. Set meas. range selection switch (2) to range 1.
3. Fill the vessel up to the requested level.
4. Turn potentiometer (1) to position 10.

When the control lamp (6) lights red: set the measuring range selection switch (2) to the next higher measuring range.

When the control lamp (6) lights green: continue with the next item.

5. Turn the potentiometer (1) very slowly anticlockwise until the control lamp (6) lights red.

The measuring system is now ready for operation.

### Mode min. (min. level detection)

















1. Set mode switch (3) to mode min.
2. Set meas. range selection switch (2) to range 1.
3. Lower the level to the requested min. level.
4. Turn the potentiometer (1) to 0, the control lamp (6) lights green.

- Turn the potentiometer (1) very slowly clockwise until the control lamp (6) lights red. If the control lamp does not light red, set the meas. range selection switch (2) to the next higher stage and repeat the setting with the potentiometer (1) until the control lamp lights red.

The measuring system is now ready for operation.

### 6.3 Function table

The following table provides an overview of the switching conditions depending on the set mode and the level.

	Level	Switching status	Control lamp
Mode max. Overflow protection		 Switch closed	 Green
Mode max. Overflow protection		 Switch open	 Red
Mode min. Dry run protection		 Switch closed	 Green
Mode min. Dry run protection		 Switch open	 Red
Failure of the supply voltage (min./max. mode)	any	 Switch open	
Fault	any	 Switch open	 flashes red

## 7 Maintenance and fault rectification

### 7.1 Maintenance

If the device is used properly, no special maintenance is required in normal operation.

### 7.2 Rectify faults

#### Reaction when malfunction occurs

The operator of the system is responsible for taking suitable measures to rectify faults.

#### Causes of malfunction

VEGACAP 67 offers maximum reliability. Nevertheless, faults can occur during operation. These may be caused by the following, e.g.:

- Sensor
- Process
- Voltage supply
- Signal processing

#### Fault rectification

The first measure to take is to check the output signal. In many cases, the causes can be determined this way and the faults quickly rectified.

#### 24 hour service hotline

Should these measures not be successful, please call in urgent cases the VEGA service hotline under the phone no. **+49 1805 858550**.

The hotline is manned 7 days a week round-the-clock. Since we offer this service worldwide, the support is only available in the English language. The service is free, only standard call charges are incurred.

#### Checking the switching signal

Error	Reason	Rectification
<ul style="list-style-type: none"> <li>● The instrument signals covered without covering with the medium</li> <li>● The instrument signals covered with covering with the medium</li> </ul>	Wrong mode selected on the signal conditioning instrument	Set the correct mode on the mode switch of the signal conditioning instrument (A: overflow protection, B: dry run protection). Wiring should be carried out according to the idle current principle.
	Operating voltage too low	Check operating voltage
	Shortcircuit in the probe, e.g. because of moisture in the housing	Remove the electronics module. Check the resistance between the marked plug connections. See the following instructions.
	Electronics defective	Push the mode switch (A/B) on the signal conditioning instrument. If the signal conditioning instrument then changes the mode, the probe may be mechanically damaged. Should the switching function in the correct mode still be faulty, return the probe for repair.  Check if there is buildup on the probe, and if so, remove it.
	Unfavourable installation location	Check if the probe is covered by buildup on the socket. Mount the instrument at a location in the vessel where e.g. no mounds can form.
Signal lamp flashes red	Electronics module has detected a failure	Exchange the instrument or send it in for repair

**Check the resistance in the probe**

Remove the electronics module. Check the resistance between the two plug connections.

There must no longer be a connection (high impedance). If there is still a connection, exchange the instrument or return it for repair

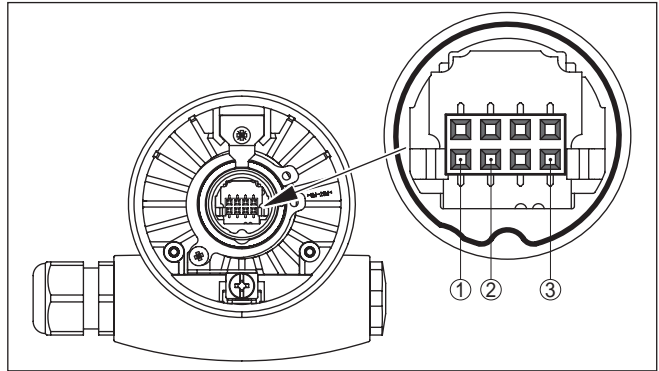

Fig. 29: Check the resistance in the probe

- 1 Shielding
- 2 Measuring probe
- 3 Ground potential

**Reaction after fault rectification**

Depending on the reason for the fault and the measures taken, the steps described in chapter "Set up" may have to be carried out again.

**7.3 Exchange of the electronics module**

In general, all electronics modules of series CP60 can be interchanged. If you want to use an electronics module with a different signal output, you can download the corresponding operating instructions manual from our homepage under Downloads.

Proceed as follows:

1. Switch off power supply
2. Unscrew the housing lid
3. Lift the opening levers of the terminals with a screwdriver
4. Pull the connection cables out of the terminals
5. Loosen the two screws with a screw driver (Torx size T10 or slot 4)

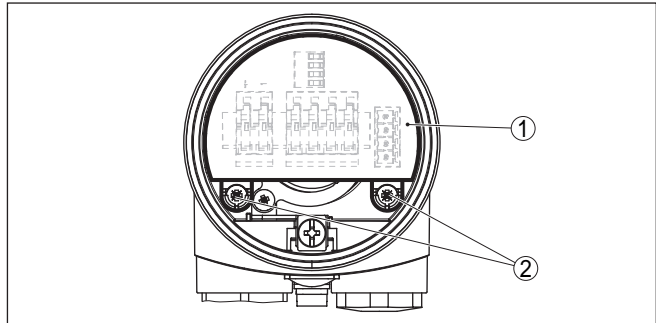

Fig. 30: Loosen the holding screws

- 1 Electronics module
- 2 Screws (2 pcs.)

6. Pull out the old electronics module
7. Compare the new electronics module with the old one. The type label of the electronics module must correspond to that of the old electronics module. This applies particularly to instruments used in hazardous areas.
8. Compare the settings of the two electronics modules. Set the adjustment elements of the new electronics module to the same setting of the old one.



#### Information:

Make sure that the housing is not rotated during the electronics exchange. Otherwise the plug may be in a different position later.

9. Insert the electronics module carefully. Make sure that the plug is in the correct position.
10. Screw in and tighten the two holding screws with a screwdriver (Torx size T10 or Phillips 4)
11. Insert the wire ends into the open terminals according to the wiring plan
12. Press down the opening levers of the terminals, you will hear the terminal spring closing
13. Check the hold of the wires in the terminals by lightly pulling on them
14. Check cable gland on tightness. The seal ring must completely encircle the cable.
15. Mount the probe into the vessel. Make sure that the probe is uncovered.

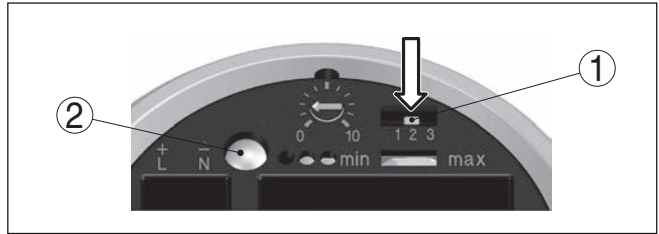

Fig. 31: Compensation key

- 1 Measuring range selection switch (compensation key)
- 2 Control lamp

- 16. Keep the measuring range selection switch (1) pushed until the control lamp (2) flashes green.
  - 17. Carry out the adjustment again. See chapter "Set-up, adjustment elements".
  - 18. Screw the housing lid back on
- The electronics exchange is now finished.

### 7.4 Shortening of the probe

The rod of the probe can be shortened to any length.

- 1. Shorten the rod probe to the requested length with a metal saw.
- 2. Mount the probe into the vessel. Make sure that the probe is uncovered.

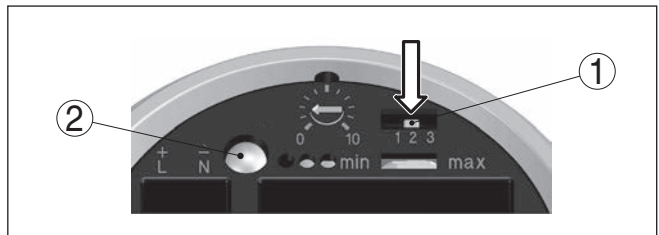

Fig. 32: Compensation key

- 1 Measuring range selection switch (compensation key)
- 2 Control lamp

- 3. Keep the measuring range selection switch (1) pushed until the control lamp (2) flashes green.
- 4. Hence the probe is compensated to the modified length.
- 5. Carry out the adjustment again. See chapter "Set-up, adjustment elements".

### 7.5 How to proceed if a repair is necessary

You can find an instrument return form as well as detailed information about the procedure in the download area of our homepage: [www.vega.com](http://www.vega.com).

By doing this you help us carry out the repair quickly and without having to call back for needed information.

If a repair is necessary, please proceed as follows:

- Print and fill out one form per instrument
- Clean the instrument and pack it damage-proof
- Attach the completed form and, if need be, also a safety data sheet outside on the packaging
- Please contact the agency serving you to get the address for the return shipment. You can find the agency on our home page [www.vega.com](http://www.vega.com).

## 8 Dismount

### 8.1 Dismounting steps

**Warning:**

Before dismantling, be aware of dangerous process conditions such as e.g. pressure in the vessel, high temperatures, corrosive or toxic products etc.

Take note of chapters "*Mounting*" and "*Connecting to power supply*" and carry out the listed steps in reverse order.

### 8.2 Disposal

The instrument consists of materials which can be recycled by specialised recycling companies. We use recyclable materials and have designed the electronics to be easily separable.

**WEEE directive 2002/96/EG**

This instrument is not subject to the WEEE directive 2002/96/EG and the respective national laws. Pass the instrument directly on to a specialised recycling company and do not use the municipal collecting points. These may be used only for privately used products according to the WEEE directive.

Correct disposal avoids negative effects on humans and the environment and ensures recycling of useful raw materials.

Materials: see chapter "*Technical data*"

If you have no way to dispose of the old instrument properly, please contact us concerning return and disposal.

## 9 Supplement

### 9.1 Technical data

#### General data

Material 316L corresponds to 1.4404 or 1.4435

Process fitting G1½, 1½ NPT

Materials, wetted parts

- Process fitting - thread 316L
- Process fitting - flange 316L
- Process seal Klingersil C-4400
- Insulation (partly insulated) Ceramic (KER 221 according to DIN 40685)
- Probe - rod, ceramic partly insulated 316L  
(ø 15 mm/0.591 in)
- Probe - cable, ceramic partly insulated 316 (1.4401)  
(ø 8 mm/0.315 in)<sup>1)</sup>
- Gravity weight 316L

Materials, non-wetted parts

- Plastic housing plastic PBT (Polyester)
- Aluminium die-cast housing Aluminium die-casting AlSi10Mg, powder-coated (basis: Polyester)
- Stainless steel housing (precision casting) 316L
- Stainless steel housing (electropolished) 316L
- Seal between housing and housing lid Silicone
- Ground terminal 316L
- Cable gland PA, stainless steel, brass
- Sealing, cable gland NBR
- Blind plug, cable gland PA

Process fittings

- Pipe thread, cylindrical (DIN 3852-A) G1½
- Pipe thread, conical (ASME B1.20.1) 1½ NPT
- Flanges DIN from DN 40, ASME from 1½"

Weight

- Instrument weight (depending on process fitting) 0.8 ... 4 kg (0.18 ... 8.82 lbs)
- Gravity weight 1800 g (64 oz)
- Rod weight: ø 15 mm (0.591 in) 1400 g/m (15 oz/ft)
- Cable weight: ø 8 mm (0.315 in) 400 g/m (4.3 oz/ft)

Sensor length (L)

- Rod (ø 15 mm/0.591 in) 0.275 ... 6 m (0.902 ... 19.69 ft)

<sup>1)</sup> Cable connected electrically conductive with the gravity weight.

– Cable (ø 8 mm/0.315 in)	0.53 ... 40 m (1.74 ... 131.23 ft)
Supporting tube length L1	0.2 ... 5.6 m (0.656 ... 18.37 ft)
Max. lateral load	10 Nm (7.4 lbf ft)
Max. tensile load (cable)	
– Ceramic partly insulated: ø 8 mm (0.315 in)	10 KN (2248 lbf)
Max. torque (process fitting - thread)	80 Nm (58 lbf ft)
Torque for NPT cable glands and Conduit tubes	
– Plastic housing	max. 10 Nm (7.376 lbf ft)
– Aluminium/Stainless steel housing	max. 50 Nm (36.88 lbf ft)
Measuring frequency	430 kHz

---

**Output variable**

Output	Contactless electronic switch
Modes (switchable)	Min./Max.
Switching delay	
– When immersed	0.7 s
– When laid bare	0.7 s
– In the event of a fault	1 s

---

**Accuracy (according to DIN EN 60770-1)**

Reference conditions according to DIN EN 61298-1	
– Temperature	+18 ... +30 °C (+64 ... +86 °F)
– Relative humidity	45 ... 75 %
– Air pressure	860 ... 1060 mbar/86 ... 106 kPa (12.5 ... 15.4 psig)
Deviation due to strong, high-frequency electromagnetic fields acc. to EN 61326	< 3 % of the adjusted measuring range <sup>2)</sup>
Influence of the ambient temperature	< 0.15 %/10 K of the adjusted measuring range <sup>3)</sup>

---

**Ambient conditions**

Ambient temperature on the housing	-40 ... +80 °C (-40 ... +176 °F)
Storage and transport temperature	-40 ... +80 °C (-40 ... +176 °F)

---

**Process conditions**

Process pressure	-1 ... 16 bar/-100 ... 1600 kPa (-14.5 ... 232 psig)
Process temperature (thread or flange temperature)	
– Standard	-50 ... +300 °C (-58 ... +572 °F)
– with external housing	-50 ... +400 °C (-58 ... +752 °F)

<sup>2)</sup> Distance from the process fittings to the set switching point.

<sup>3)</sup> Distance from the process fittings to the set switching point.

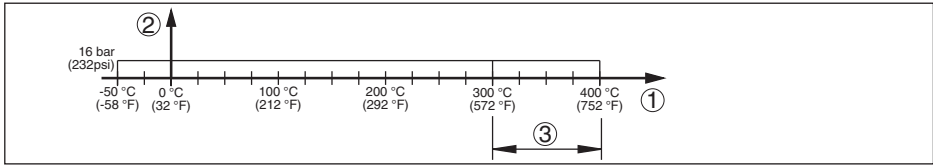

Fig. 33: Process temperature - Process pressure

- 1 Process temperature  
 2 Process pressure  
 3 Temperature range with external housing

Dielectric constant  $\geq 1.5$

### Electromechanical data

Cable entry/plug (dependent on the version)

- Single chamber housing
    - 1 x cable entry M20 x 1.5 (cable:  $\varnothing$  5 ... 9 mm),  
1 x blind plug M20 x 1.5; attached 1 x cable entry M20 x 1.5
    - or:
    - 1 x cable entry  $\frac{1}{2}$  NPT, 1 x blind plug  $\frac{1}{2}$  NPT, 1 x cable entry  $\frac{1}{2}$  NPT
    - or:
    - 1 x plug M12 x 1; 1 x blind plug M20 x 1.5
- Spring-loaded terminals for wire cross-section up to 1.5 mm<sup>2</sup> (AWG 16)

### Adjustment elements

Mode switch

- Min. Min. detection or dry run protection
- Max. Max. detection or overflow protection

DIL switch for measuring range selection

- range 1 0 ... 20 pF
- range 2 0 ... 85 pF
- range 3 0 ... 450 pF

Potentiometer

Switching point adaptation

### Voltage supply

Operating voltage 20 ... 253 V AC, 50/60 Hz, 20 ... 253 V DC

Domestic current requirement approximately 3 mA (via load circuit)

Load current

- Min. 10 mA
- Max. 400 mA (at  $I > 300$  mA the ambient temperature can be max. 60 °C/140 °F) max. 4 A up to 40 ms

### Electrical protective measures

Protection rating IP 66/IP 67 (NEMA Type 4X)

Overvoltage category III

Protection class I

## 9.2 Dimensions

### VEGACAP 67, housing

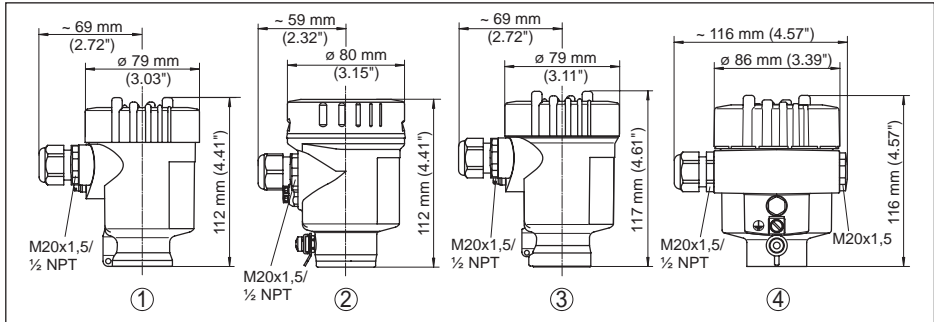

Fig. 34: Housing versions

- 1 Plastic single chamber
- 2 Stainless steel single chamber (electropolished)
- 3 Stainless steel single chamber (precision casting)
- 4 Aluminium - single chamber

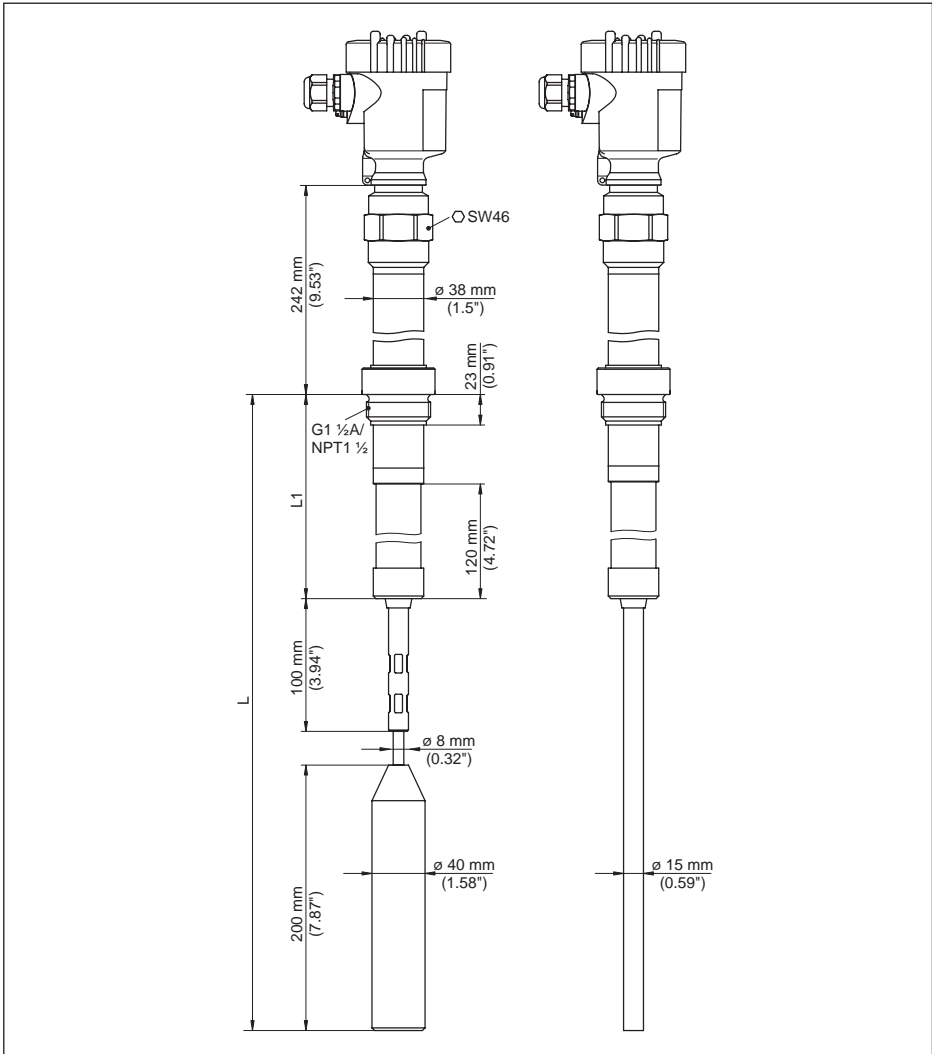

Fig. 35: VEGACAP 67, threaded version  $G1\frac{1}{2}$  (ISO 228 T1) and  $1\frac{1}{2}$  NPT,  $-50 \dots +300\text{ }^{\circ}\text{C}$  ( $-58 \dots +572\text{ }^{\circ}\text{F}$ )

Version  $-50 \dots +400\text{ }^{\circ}\text{C}$  ( $-58 \dots +752\text{ }^{\circ}\text{F}$ ) only with external housing.

See supplementary instructions manual "External housing - VEGACAP, VEGACAL"

$L$  Sensor length, see chapter "Technical data"

$L_1$  Supporting tube length, see chapter "Technical data"

### 9.3 Industrial property rights

VEGA product lines are global protected by industrial property rights. Further information see [www.vega.com](http://www.vega.com).

VEGA Produktfamilien sind weltweit geschützt durch gewerbliche Schutzrechte.

Nähere Informationen unter [www.vega.com](http://www.vega.com).

Les lignes de produits VEGA sont globalement protégées par des droits de propriété intellectuelle. Pour plus d'informations, on pourra se référer au site [www.vega.com](http://www.vega.com).

VEGA líneas de productos están protegidas por los derechos en el campo de la propiedad industrial. Para mayor información revise la pagina web [www.vega.com](http://www.vega.com).

Линии продукции фирмы ВЕГА защищаются по всему миру правами на интеллектуальную собственность. Дальнейшую информацию смотрите на сайте [www.vega.com](http://www.vega.com).

VEGA系列产品在全球享有知识产权保护。

进一步信息请参见网站[www.vega.com](http://www.vega.com)。

### 9.4 Trademark

All the brands as well as trade and company names used are property of their lawful proprietor/originator.

Printing date:

# VEGA

All statements concerning scope of delivery, application, practical use and operating conditions of the sensors and processing systems correspond to the information available at the time of printing.

Subject to change without prior notice

© VEGA Grieshaber KG, Schiltach/Germany 2017



31314-EN-170503

VEGA Grieshaber KG  
Am Hohenstein 113  
77761 Schiltach  
Germany

Phone +49 7836 50-0  
Fax +49 7836 50-201  
E-mail: [info.de@vega.com](mailto:info.de@vega.com)  
[www.vega.com](http://www.vega.com)