

3300 XL NSv* Proximity Transducer System

Bently Nevada* Asset Condition Monitoring

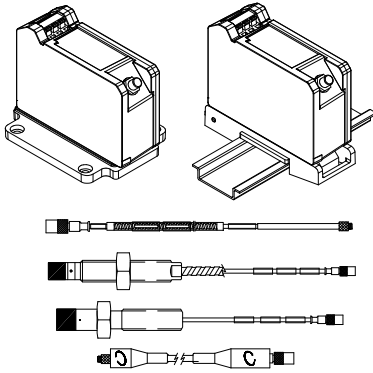

Description

The 3300 XL NSv* Proximity Transducer system is intended for use with centrifugal air compressors, refrigeration compressors, process gas compressors and other machines with tight installation requirements. The 3300 XL NSv Proximity Transducer System consists of:

- a 3300 NSv probe
- a 3300 NSv extension cable
- a 3300 XL NSv Proximito^r* Sensor.¹

The primary uses for the 3300 XL NSv Transducer System are for areas where counter bore, sideview or rearview restrictions limit the use of standard Bently Nevada* 3300 and 3300 XL 5 and 8 mm Transducer Systems. It is also ideal for small target applications, such as measuring radial vibration on shafts smaller than 51 mm (2 in) or axial position on flat targets smaller than 15 mm (0.6 in). It is primarily used in the following applications on fluid-filmed bearing machines where a small shaft or reduced side-view is present:

- Radial vibration and radial position measurements
- Axial (thrust) position measurements
- Tachometer and zero speed measurements
- Phase reference (Keyphasor*) signals

The 3300 XL NSv Transducer System design allows it to replace both the 3300 RAM Transducer Systems and the 3000-series or 7000-series 190 Transducer System. Upgrades from the 3300 RAM system to the 3300 XL NSv system may use the existing probe, extension cable, and monitoring system with 3300 XL NSv Proximito^r Sensor. Upgrades from the 3000-series or 7000-series Transducer System must replace the probe, extension cable and Proximito^r Sensor with NSv components.

The 3300 XL NSv Transducer System has an Average Scale Factor of 7.87 V/mm (200 mV/mil), which is the most common output for eddy current transducers. Its enhanced side-view and small target characteristics give it a shorter linear range than the Bently Nevada 3300 XL-series 5 and 8 mm Transducer System. With The 1.5 mm (60 mils) of linear range exceeds the linear range of the 3000-series 190 Transducer System.

Application Alert: Although the terminals and connector on the Proximito^r Sensor have protection against electrostatic discharge, take reasonable precautions to avoid electrostatic discharge during handling.

Proximito Sensor

The 3300 XL NSv Proximito Sensor has similar features to those found in the 3300 XL 8 mm Proximito Sensor. Its thin design allows the user to mount it in either a high-density DIN-rail installation or a more traditional panel mount configuration. Improved RFI/EMI immunity allows the 3300 XL NSv Proximito Sensor to achieve European CE mark approvals without any special mounting considerations. This RFI immunity also prevents nearby high frequency radio signals from adversely affecting the transducer system. SpringLoc terminal strips on the Proximito Sensor require no special installation tools and facilitate faster, highly robust field wiring connections.

Proximity Probe and Extension Cable

The 3300 NSv probe and extension cable are mechanically and electrically compatible and interchangeable with Bently Nevada's previous 3300 RAM proximity probe and extension cable. The NSv probe has increased chemical resistance compared to the 3300 RAM probe, which allows its use in many process compressor applications. The side-view characteristics of the 3300 NSv probe are also superior to those of the 3000-series 190 probe when gapping the 3300 NSv probe at the same distance from the probe target.

The 3300 NSv probe comes in varying probe case configurations, including armored and unarmored ¼ -28, ⅜ -24, M8 X 1 and M10 X 1 probe threads. The reverse mount 3300 NSv probe comes standard with either ⅜ -24 or M10 X 1 threads. All components of the transducer system have gold-plated brass ClickLoc* connectors. ClickLoc connectors lock into place and prevent the connection from loosening. The patented TipLoc* molding method provides a robust bond between the probe tip and the probe body. Bently Nevada's patented CableLoc* design provides 220 N (50 lb) of pull strength and securely attaches the probe cable to the probe tip. Connector protectors are recommended for use on the probe-to-extension cable connection, as well as on the cable-to-Proximito Sensor connection. Connector protectors prevent most liquids from entering into the ClickLoc connectors and adversely affecting the electrical signal².

Notes:

1. Proximito Sensors are supplied by default from the factory calibrated to AISI 4140 steel. Calibration to other target materials is available upon request.

2. Silicone tape is also provided with each 3300 NSv extension cable and can be used instead of connector protectors. Silicone tape is not recommended in applications where the probe-to-extension cable connection will be exposed to turbine oil.

Specifications

Unless otherwise noted, the following specifications are for a 3300 XL NSv Proximito Sensor, extension cable and probe between 0°C and +45°C (+32°F to +113°F), with a -24 Vdc power supply, a 10 kΩ load, a Bently Nevada supplied AISI 4140 steel target that is 31 mm (1.2 in) diameter or larger, and a probe gap of 1.0 mm (40 mils). The system accuracy and interchangeability specifications do not apply when using a transducer system calibrated to any target other than a Bently Nevada AISI 4140 steel target.

Electrical

Proximito Sensor Input

Accepts one non-contacting 3300 RAM or 3300 NSv Proximity Probe and Extension Cable.

Power

Requires -17.5 Vdc to -26 Vdc without barriers at 12 mA maximum consumption, -23 Vdc to -26 Vdc with barriers. Operation at a more positive voltage than -23.5 Vdc can result in reduced linear range.

Supply Sensitivity

Less than 2 mV change in output voltage per volt change in input voltage.

Output resistance

50 Ω

Probe dc resistance:

Probe Length (m)	Resistance from the Center Conductor to the Outer Conductor (R_{PROBE}) (ohms)
0.5	4.0 ± 0.5
1.0	4.2 ± 0.5
5.0	5.3 ± 0.7
7.0	5.9 ± 0.9

Extension cable dc resistance:

Center conductor: 0.220Ω/m (0.067 Ω/ft)
 Shield: 0.066 Ω/m (0.020 Ω/ft)

Extension cable capacitance:

69.9 pF/m (21.3 pF/ft) typical

Field wiring:

0.2 to 1.5 mm² (16 to 24 AWG) [0.25 to 0.75 mm² (18 to 23 AWG) with ferrules].
 Recommend using three-conductor shielded triad cable. Maximum length of 305 metres (1,000 feet) between the 3300 XL NSv Proximitor Sensor and the monitor. See the frequency response graphs Figure 16 and Figure 17 for signal rolloff at high frequencies when using longer field wiring lengths.

Linear Range:

1.5 mm (60 mils). Linear range begins at approximately 0.25 mm (10 mils) from target and is from 0.25 to 1.75 mm (10 to 70 mils) (approximately -1 to -13 Vdc).

Recommended Gap Setting:

1.0 mm (40 mils)

System performance over ambient temperature range (0°C to 45°C):

Incremental Scale Factor (ISF)

7.87 V/mm (200 mV/mil) +12.5%/-20% including interchangeability error when measured in increments of 0.25 mm (10 mils) over the 1.5 mm (60 mil) linear range.

Deviation from best fit straight line (DSL)

Less than ±0.06 mm (±2.3 mils).

Frequency Response:

0 to 10 kHz: +0, -3 dB typical, with up to 305 metres (1000 feet) of field wiring.

Target Size (flat target):

Minimum: 8.9 mm (0.35 in) diameter

Recommended minimum: 13 mm (0.5 in) diameter

Axial position measurements on shaft diameters smaller than 13mm (0.5 in) will generally result in a change in scale factor. Reducing the gap between the probe and target will help limit the change in scale factor. See Figure 12 for additional information.

Shaft Diameter

Minimum (standard X-Y probe configuration): 30 mm (1.2 in)

Minimum (X-Y proximity probes offset axially by 23 mm (0.9 in)): 20 mm (0.8 in)

Measurements on shaft diameters smaller than 30 mm (1.2 in) usually require close spacing of radial vibration or axial position transducers. This creates the potential for their

electromagnetic emitted fields to interact with one another (cross-talk), resulting in erroneous readings. To prevent cross-talk, maintain minimum separation of transducer tips of at least 25 mm (1.0 in) for axial position measurements or 23 mm (0.9 in) for radial vibration measurements (see Figure 14 and Figure 15 for additional information.) Radial vibration or radial position measurements on shaft diameters smaller than 20 mm (0.8 in) will generally result in greater than a 10% change in Average Scale Factor (ASF). See Figure 13 for additional information.

Counterbore

Minimum: 9.5 mm (0.375 in)

Recommended minimum: 13 mm (0.5 in)

Counterbores smaller than 13 mm (0.5 in) generally result in a change in scale factor at far gaps. Reducing the gap between the probe and the target will allow the transducer system to maintain its Average Scale Factor (ASF) over a reduced linear range. See Figure 9 for additional information.

Effects of 60 Hz Magnetic Fields Up to 300 Gauss (5 metre system):

Output voltage in mil pp/gauss:

Gap	Proximator Sensor	Probe	Ext. Cable
0.25 mm (10 mils)	0.006	0.001	0.001
1.0 mm (40 mils)	0.007	0.002	0.001
1.75 mm (70 mils)	0.008	0.002	0.003

Electrical Classification:

Complies with the European CE mark.

Compliance and Certifications

EMC

Standards:

EN 61000-6-2 Immunity for Industrial Environments

EN 61000-6-4 Emissions for Industrial Environments

European Community Directives:

EMC Directive 2004/108/EC

Hazardous Area Approvals

Multiple approvals for hazardous areas certified by Canadian Standards Association in North America and by BASEEFA in Europe.

North America:

Probes and Proximator Sensor

Class I, Zone 0; Ex ia IIC T1..T5 Ga:
Class I, Groups A, B, C and D; Class II Groups E, F and G; Class III, when connected to certified barriers per installation drawing 141092

Class I, Zone 2 Ex nA IIC T1...T5 Gc:
Class I, Div. 2 Groups A, B, C and D, when connected per installation drawing, 140979.

Temperature Codes

Proximity Sensors:
T4, Ta = -51°C to +100°C
T5, Ta = -35°C to +85°C

Proximity Probes:
T1, Ta = -51°C to +232°C
T2, Ta = -51°C to +177°C
T3, Ta = -51°C to +120°C
T4, Ta = -51°C to +80°C
T5, Ta = -51°C to +40°C

For further certification and approvals information please visit the following website:
http://www.ge-energy.com/prod_serv/products/oc/en/bently_nevada.htm

Probes and Proximito Sensor

Ex nA IIC; Class I, Zone 2: Class I, Div 2, Groups A, B, C, D, when installed without barriers per drawing 140979.

T₅ @ T_a = -35°C to +85°C.

ATEX:

Proximito Probes

- ⊕ II 1G Ex ia IIC T1...T5 Ga
- ⊕ II 1G Ex nA IIC T1...T5 Gc
- ⊕ II 3G Ex nA IIC T1...T5 Gc

Temperature Codes:
T1, T_a = -51°C to +232°C
T2, T_a = -51°C to +177°C
T3, T_a = -51°C to +120°C
T4, T_a = -51°C to +80°C
T5, T_a = -51°C to +40°C

Proximito Sensor

- ⊕ II 1 G Ex ia IIC T4/T5 Ga
- ⊕ II 3 G Ex nA IIC T4/T5 Gc

Temperature Codes:
T4 = -51°C ≤ T_a ≤ +100°C
T5 = -35°C ≤ T_a ≤ +85°C

IECEX:

Probes

Ex ia IIC T1..T5 Ga
Ex nA IIC T1..T5 Gc

Temperature Codes
T1, T_a = -51°C to +232°C
T2, T_a = -51°C to +177°C
T3, T_a = -51°C to +120°C
T4, T_a = -51°C to +80°C
T5, T_a = -51°C to +40°C

Proximito Sensor

Ex ia IIC T4/T5 Ga
Ex nA II T4/T5 Gc

Temperature Codes
T4 = -51°C ≤ T_a ≤ +100°C
T5 = -35°C ≤ T_a ≤ +85°C

Mechanical

Probe Tip

Material:

Polyphenylene sulfide (PPS).

Probe Case

Material:

AISI 304 stainless steel (SST).

Probe Cable

Specifications:

75 Ω coaxial, fluoroethylene propylene (FEP) insulated probe cable in the following total probe lengths: 0.5, 1, 5, or 7 metres.

Extension Cable

Material:

75 Ω coaxial, fluoroethylene propylene (FEP) insulated.

Proximito

Sensor Material:

A380 aluminum

System Length:

5 or 7 metres including extension cable

Extension Cable

Armor

(optional):

Flexible AISI 302 SST with/without FEP outer jacket.

Tensile Strength

(maximum rated):

220 N (50 lb) probe case to probe lead. 220 N (50 lb) at probe lead to extension cable connectors. 220 N (50 lb) probe case to stainless steel armor.

Connector material:

Gold-plated brass

Q

Recommended case hole and tap size for 1/4-28 case

Drill Size

0.213 in

Hole Size

0.218 to 0.222 in

Hole Depth

0.376 to 0.750 in

Tap Drill Size

#3

Recommended case hole and tap size for M8x1 case

Drill Size

7.4mm

Hole Size

7.511 to 7.622 mm

Hole Depth

12 to 24 mm

Tap Drill Size

L

Recommended case hole and tap size for 3/8-24 case

Drill Size

0.332 in

Hole Size

0.338 to 0.343 in

Hole Depth

0.562 to 0.813 in

Tap Drill Size

Recommended case hole and tap size for M10x1 case

Drill Size

9.4mm

Hole Size

9.541 to 9.662 mm

Hole Depth

15 to 30 mm

Tap Drill Size

U

Connector-to-connector torque

Probe case torque:	Maximum Rated	Recommended
1/4 -28 or M8x1 probe cases	7.3 N•m (65 in•lb)	5.1 N•m (45 in•lb)
3/8-24 or M10x1 probe cases	33.9 N•m (300 in•lb)	11.3 N•m (100 in•lb)
3/8-24 or M10x1 probe cases – first three threads	22.6 N•m (200 in•lb)	7.5 N•m (66 in•lb)
Reverse mount probes	22.6 N•m (200 in•lb)	7.5 N•m (66 in•lb)

Recommended

torque: Finger tight

Maximum torque: 0.56 N•m (5 in•lb)

Minimum Bend

Radius (with or without

ssst armor): 25.4 mm (1.0 in)

System Weight (typical):

Probe: Approximately 14 to 150 g (0.5 to 5.3 oz)

Extension Cable: 45 g/m (0.5 oz/ft)

Armored Extension

Cable: 64 g/m (0.7 oz/ft)

Proximitior

Sensor: 255 g (9 oz)

Environmental Limits

Probe Temperature Range

Operating

Temperature: -34°C to +177°C (-30°F to +351°F)

Storage

Temperature: -51°C to +177°C (-60°F to +351°F)

Note: Exposing the probe to temperatures below -34°C (-30°F) for a sustained period of time may cause premature failure of the pressure seal.

Extension Cable Temperature Range

Operating and Storage

Temperature: -51°C to +177°C (-60°F to +351°F)

Proximitior Sensor Temperature Range

Operating

Temperature: -35°C to +85°C (-31°F to +185°F)

Storage

Temperature: -51°C to +105°C (-60°F to +221°F)

Relative Humidity:

100% condensing, non-submersible when connectors are protected. Tested to IEC 68-2-3 damp heat.

Probe Pressure:

3300 NSv probes are designed to seal differential pressure between the probe tip and case. The probe sealing material consists of a Viton® O-ring. Probes are not pressure tested prior to shipment. Contact our custom design department if you require a test of the pressure seal for your application

Note: It is the responsibility of the customer or user to ensure that all liquids and gases are contained and safely controlled should leakage occur from a proximity probe. In addition, solutions with high or low pH values may erode the tip assembly of the probe causing media leakage into surrounding areas. Bently Nevada Inc. will not be held responsible for any damages resulting from leaking 3300 NSv Proximity Probes. In addition, 3300 NSv Proximity Probes will not be replaced under the service plan due to probe leakage.

Patents:

5,016,343

5,126,664

5,351,388

5,685,884

Components or procedures described in these patents apply to this product.

Ordering Information

3300 NSv Proximity Probes

330901 3300 NSv Probe, 1/4-28 UNF thread, without armor

330902 3300 NSv Probe, 1/4-28 UNF thread, with armor

330908 3300 NSv Probe, 3/8-24 UNF thread, without armor

330909 3300 NSv Probe, 3/8-24 UNF thread, with armor

Part Number-AXX-BXX-CXX-DXX-EXX

Option Descriptions

Specifications and Ordering Information
Part Number 147385-01
Rev. F (11/13)

A: Unthreaded Length Option
Note: Unthreaded length must be at least 0.7 inch less than the case length.
 Order in increments of 0.1 in
 Length configurations:
Maximum unthreaded length: 9.2 in
Minimum unthreaded length: 0.0 in
Example: 0 4 = 0.4 in

B: Overall Case Length Option
 Order in increments of 0.1 in
 Threaded length configurations:
Maximum case length: 9.9 in
Minimum case length: 0.8 in
Example: 2 4 = 2.4 in

C: Total Length Option
05 0.5 metre (20 in)
10 1.0 metre (39 in)
50 5.0 metres (16.4 feet)
70 7.0 metres (23.0 feet)

D: Connector and Cable-Type Option
01 Miniature coaxial ClickLoc connector with connector protector, standard cable
02 Miniature coaxial ClickLoc connector, standard cable
11 Miniature coaxial ClickLoc connector with connector protector, FluidLoc cable
12 Miniature coaxial ClickLoc connector, FluidLoc cable

E: Agency Approval Option
00 Not required
05 Multiple Approvals

3300 NSv Proximity Probes, Metric

330903 3300 NSv Probe, M8 x 1 thread, without armor

330904 3300 NSv Probe, M8 x 1 thread, with armor

330905 3300 NSv Probe, M10 x 1 thread, without armor

330910 3300 NSv Probe, M10 x 1 thread, with armor

Part Number-AXX-BXX-CXX-DXX-EXX

Option Descriptions

A: Unthreaded Length Option
Note: Unthreaded length must be at least 20 mm less than the case length.

Order in increments of 10 mm.
Length configuration:
Maximum unthreaded length: 230 mm

Minimum unthreaded length: 0 mm
Example: 0 6 = 60 mm

B: Overall Case Length Option
 Order in increments of 10 mm.
Metric thread configurations:
Maximum length: 250 mm
Minimum length: 20 mm
Example: 0 6 = 60 mm

C: Total Length Option
05 0.5 metre (20 in)
10 1.0 metre (39 in)
50 5.0 metres (16.4 feet)
70 7.0 metres (23.0 feet)

D: Connector and Cable-Type Option
01 Miniature coaxial ClickLoc connector with connector protector, standard cable
02 Miniature coaxial ClickLoc connector, standard cable
11 Miniature coaxial ClickLoc connector with connector protector, FluidLoc cable
12 Miniature coaxial ClickLoc connector, FluidLoc cable

E: Agency Approval Option
00 Not required
05 Multiple Approvals

3300 NSv Reverse Mount Probe

330906-02-12- CXX-DXX-EXX, 3/8-24 UNF threads

330907-05-30- CXX-DXX-EXX, M10 x 1 threads

Option Descriptions

C: Total Length Option
05 0.5 metre (20 in)
10 1.0 metre (39 in)
50 5.0 metres (16.4 feet)
70 7.0 metres (23.0 feet)

D: Connector Option
02 Miniature coaxial ClickLoc connector, standard cable
12 Miniature coaxial ClickLoc connector, FluidLoc cable

E: Agency Approval Option
00 Not required
05 Multiple Approvals

Note: For a shorter delivery time, order commonly stocked probes. Currently, stocked probes consist of the following part numbers: 330901-00-24-05-02-00, 330901-00-90-05-02-00, 330902-00-50-05-02-00, 330902-00-95-05-02-00, 330903-00-02-10-02-00, 330903-00-03-10-02-00, 330906-02-12-05-02-00.

3300 XL NSv Proximito Sensor

330980-AXX-BXX

Option Descriptions

A: Total Length and Mounting Option

- 5 0** 5.0 metre (16.4 feet) system length, panel mount
- 5 1** 5.0 metre (16.4 feet) system length, DIN mount
- 5 2** 5.0 metre (16.4 feet) system length, no mounting hardware¹
- 7 0** 7.0 metres (23.0 feet) system length, panel mount
- 7 1** 7.0 metres (23.0 feet) system length, DIN mount
- 7 2** 7.0 metres (23.0 feet) system length, no mounting hardware¹

B: Agency Approval Option

- 0 0** Not required
- 0 5** Multiple approvals

Country specific approvals may be available, consult your local Customer Care Representative for more information.

3300 NSv Extension Cable

330930-AXXX-BXX-CXX

Note: Make sure that the extension cable length and the probe length, when added together, equal the Proximito® Sensor total length.

Option Descriptions

A: Cable Length Option

- 0 4 0** 4.0 metres (13.1 feet)
- 0 4 5** 4.5 metres (14.8 feet)
- 0 6 0** 6.0 metres (19.7 feet)
- 0 6 5** 6.5 metres (21.3 feet)

B: Connector and Cable Option

- 0 0** Without stainless steel armor
- 0 1** With stainless steel armor, with FEP jacket
- 0 2** With stainless steel armor, without FEP jacket
- 0 3** Without stainless steel armor, with connector protectors
- 0 4** With stainless steel armor, with FEP jacket, with connector protectors
- 0 5** With stainless steel armor, without FEP jacket, with connector protectors
- 0 6** FluidLoc cable without stainless steel armor
- 0 7** FluidLoc cable with stainless steel armor, with FEP jacket
- 0 8** FluidLoc cable with stainless steel armor, without FEP jacket
- 0 9** FluidLoc without stainless steel armor, with connector protectors
- 1 0** FluidLoc cable with stainless steel armor, with FEP jacket, with connector protectors
- 1 1** FluidLoc cable with stainless steel armor, without FEP jacket, with connector protectors

C: Agency Approval Option

- 0 0** Not required
- 0 5** Multiple Approvals

Accessories

- 147357-01** Manual
- 02120015** Bulk field wire. 1.0 mm² (18 AWG), 3 conductor, twisted, shielded cable with drain wire. Specify length in feet.
- 138492-01** Replacement panel-mount mounting pad
- 138493-01** Replacement DIN-mount mounting pad
- 01609137** BNC (F) to banana plugs
- 01609138** Proximito Connector Test Pin wiring (two test pins to a BNC (F) connector)

40971-04 **50 Ω cable with two BNC (M) connectors.** Use this cable in combination with adapter 01609137 and adapter 01609138 when checking performance of the transducer system from the Proximitor Sensor test pin holes.

04310310 **3300 XL Proximitor Sensor Panel-mount Screws.** Package includes one 6-32 UNC thread forming mounting screw (Supplied standard with 3300 XL Proximitor Housings [3300 XL option]).

03200006 **Silicone self-fusing tape.** A 9.1 metre (10 yard) roll of silicone tape to protect connectors. It is easy to install and provides excellent electrical isolation and protection from the environment. It is not recommended for use inside the casing of the machine.

40113-03 **Connector Protector Kit.**
Connector Protector Kit for 3300 NSv probes and extension cables, including connector protectors and installation tools.

136536-01 **Connector Protector Adapter.**
Connector Protector Adapter. Allows connector protector installation tools manufactured prior to 1998 to be used with 75 Ω ClickLoc connectors.

40180-03 **Connector Protectors.** Package contains 10 pairs of connector protectors.

03800000 **Male Connector Protector.** Placed on the extension cable to connect to the female connector protector on the probe and provide environmental protection of connectors.

03800001 **Female Connector Protector.**
Placed on the probe lead to connect to the male connector protector on the extension cable and provide environmental protection of connectors. Also placed on the extension cable to slide over the Proximitor Sensor connection and protect it from the environment.

330153-05 **3300 NSv Connector Kit.** Used on 3300 NSv probes and extension cables. Contains one set of male and female ClickLoc connectors, sleeves and one strip of silicone tape.

163356 **Connector Crimp Tool Kit.** Includes one set of 75 Ω ClickLoc inserts and connector installation instructions. Supplied with carrying case.

Notes:

1. 330980 Proximitor Sensor A: options 52 and 72 come without a mounting pad and should be ordered only as spares. Each Proximitor Sensor needs a mounting pad to ensure that it is properly isolated from the housing ground.

Graphs and Dimensional Drawings

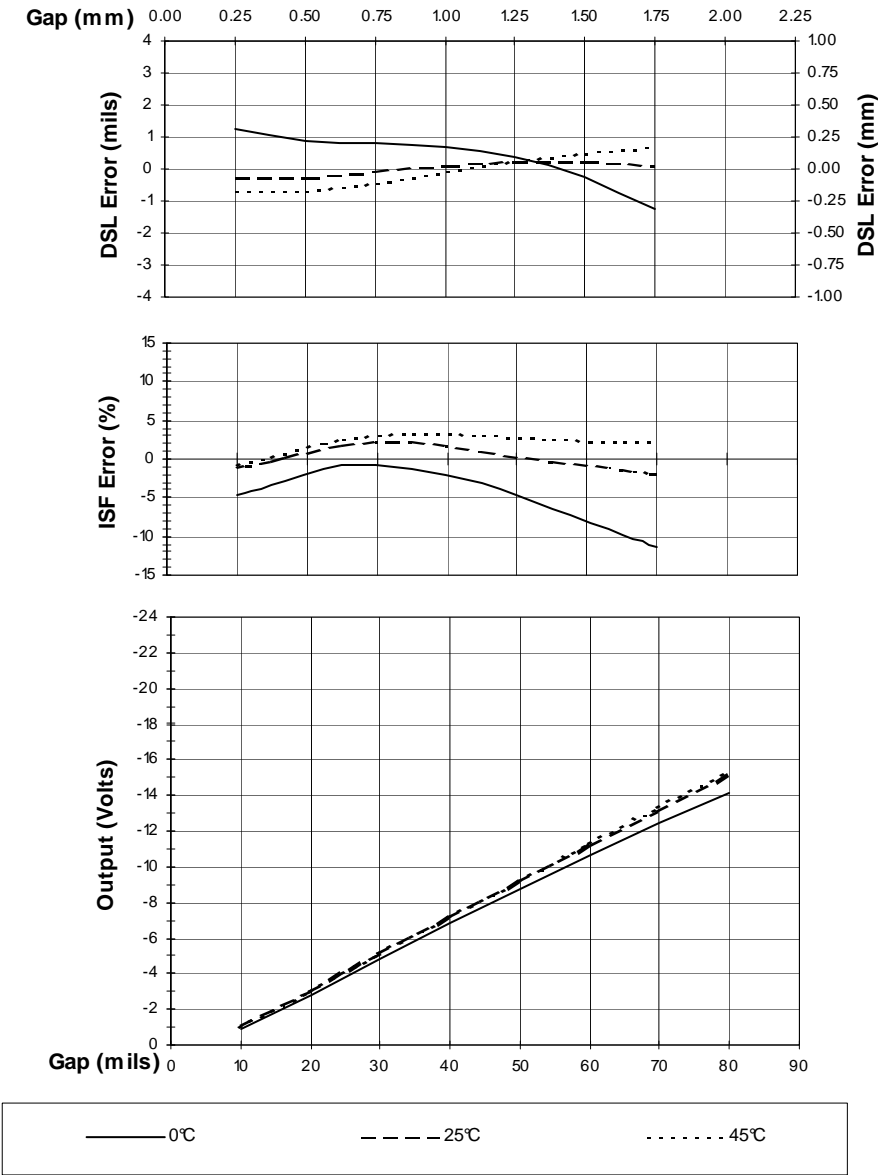

Figure 1 Typical 3300 XL NSv 5 m System over Ambient Temperature Range

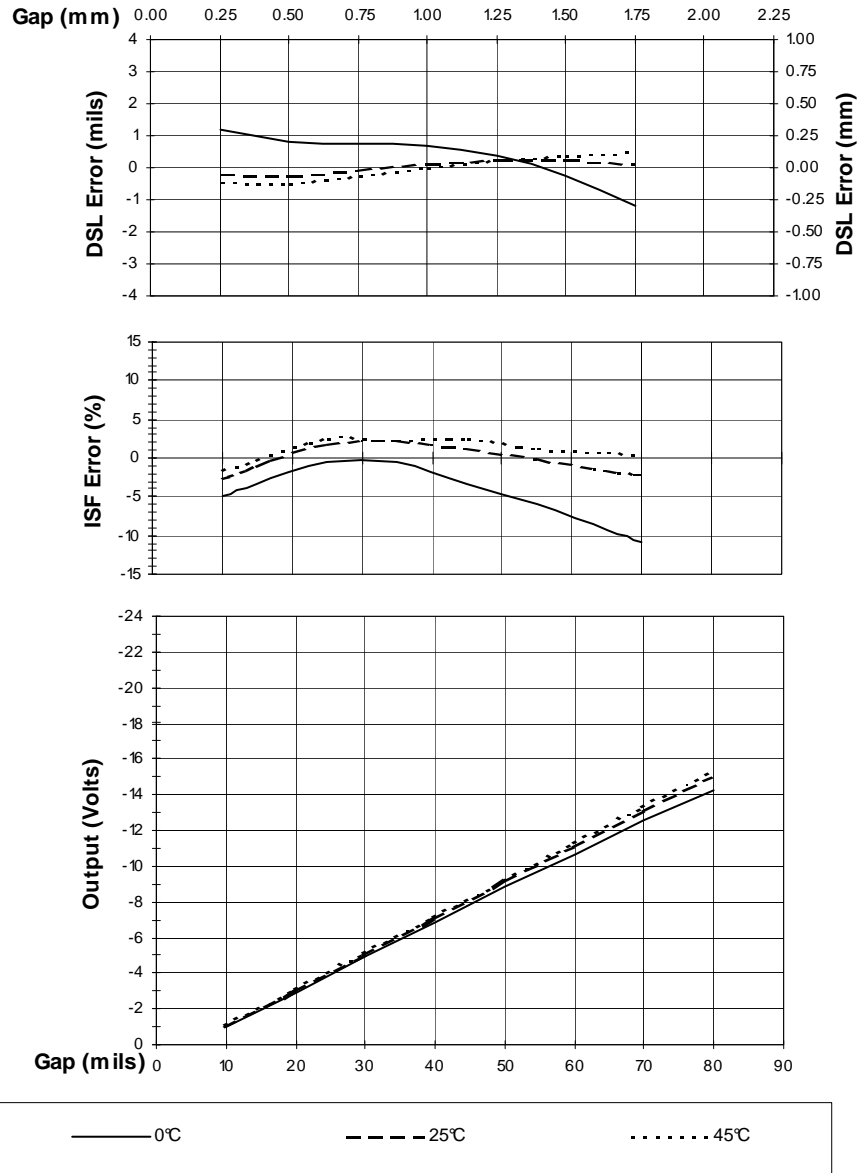

Figure 2 Typical 3300 XL NSv 7 m System over Ambient Temperature Range

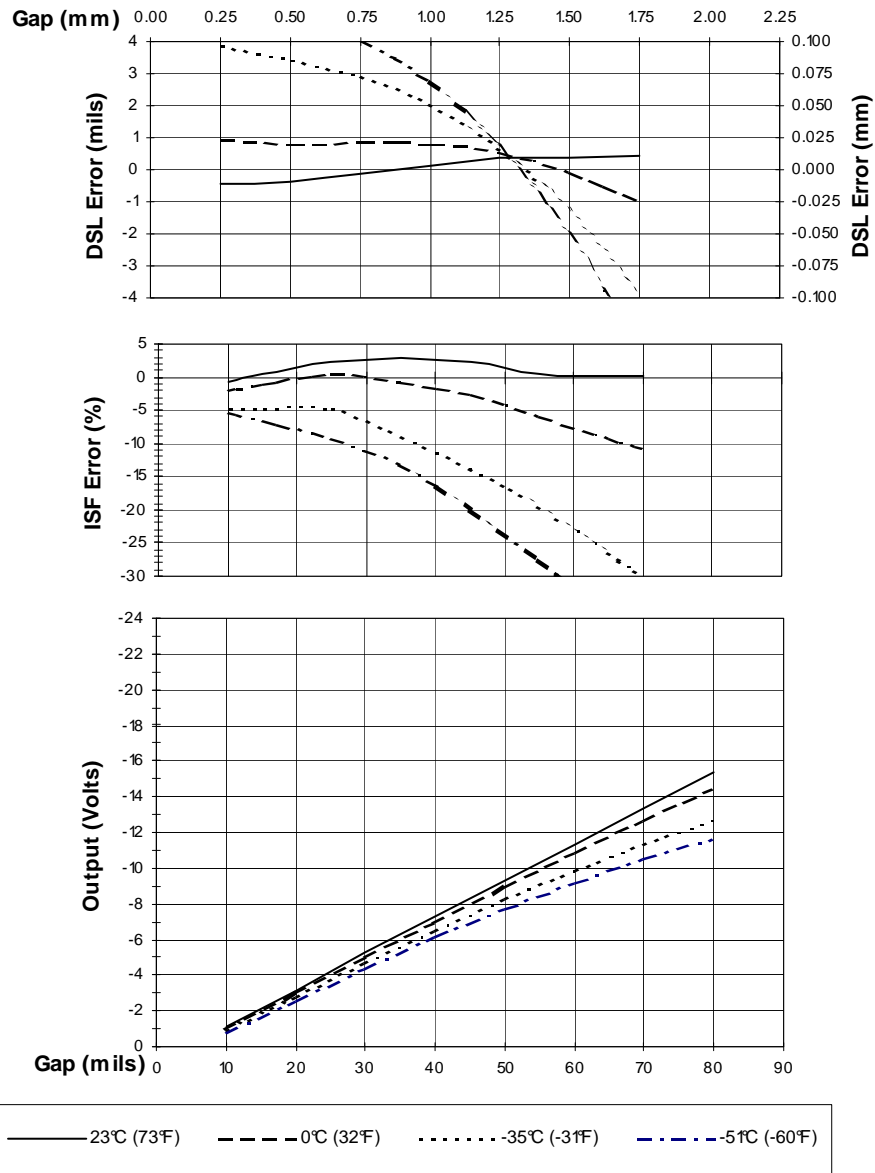

Figure 3 Typical 3300 NSv Probe + 1m Cable @ Low Temperature (Proximity Sensor + 4m of Extension Cable @ 25 °C)

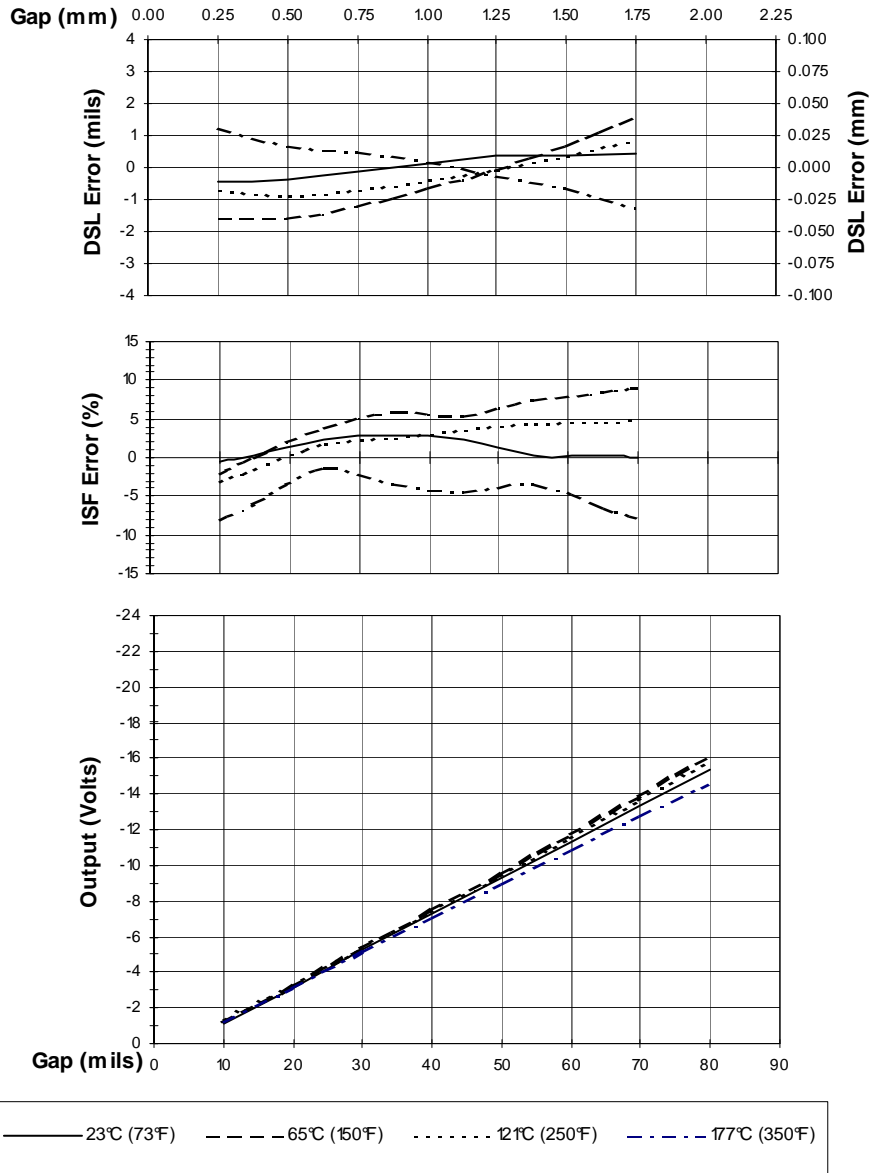

Figure 4 Typical 3300 NSv Probe + 1m Cable @ High Temperature (Proximitor Sensor + 4m of Extension Cable @ 25 °C)

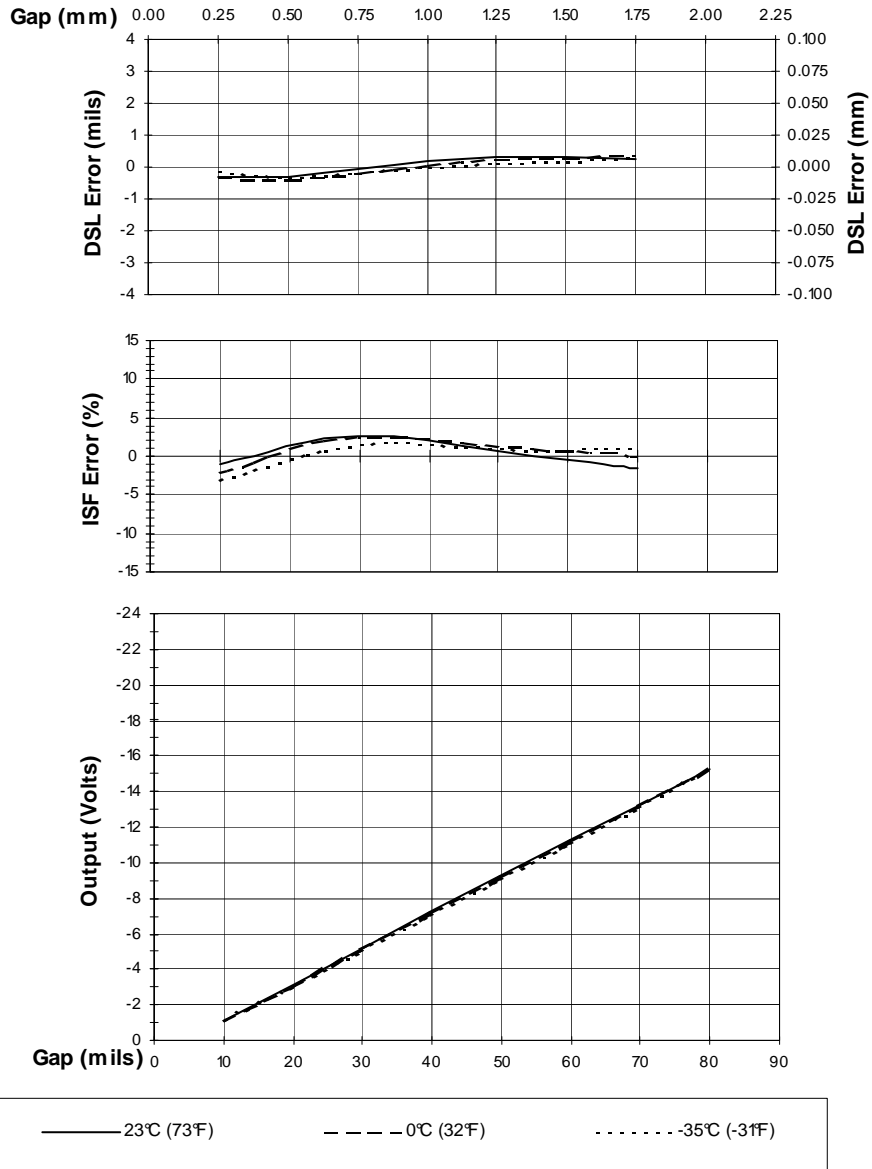

Figure 5 Typical 3300 XL NSv 5 m Proximity Sensor with 4 m of Extension Cable @ Low Temperature (Probe is at 25°C)

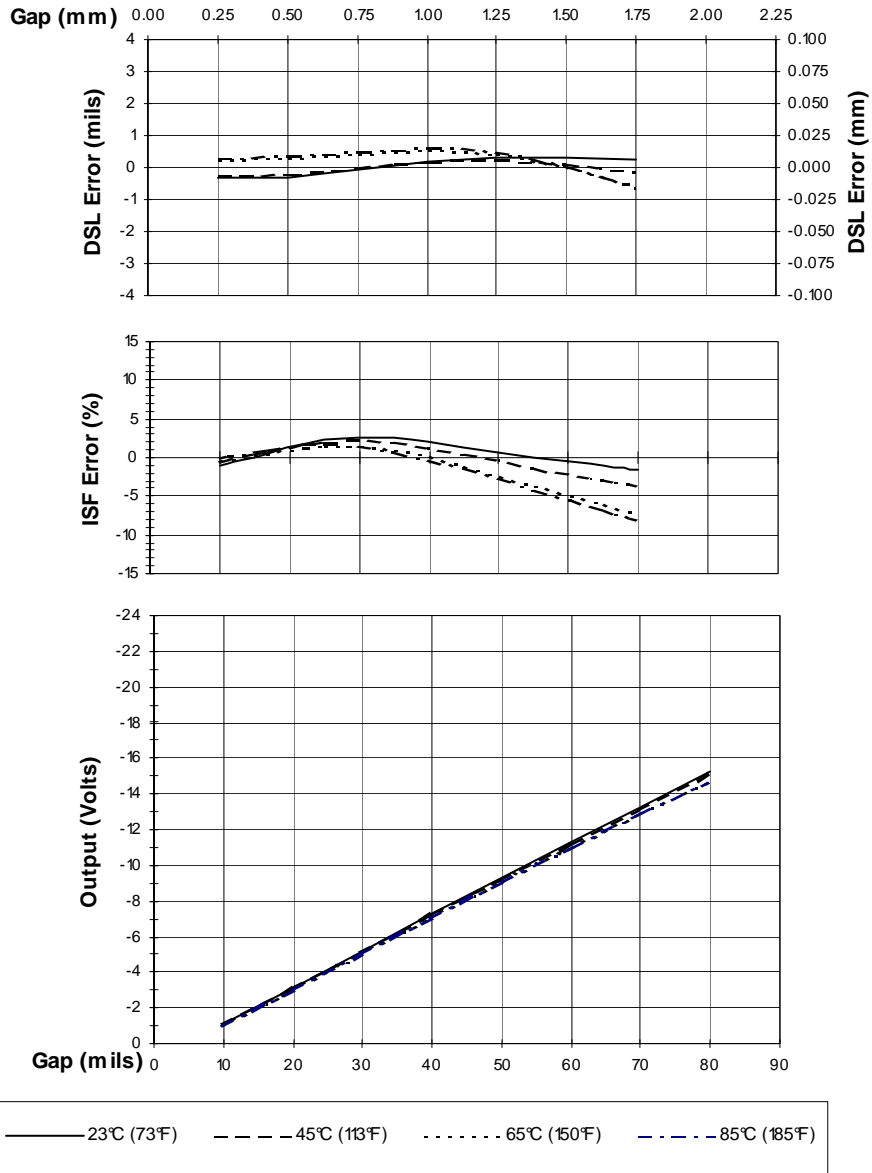

Figure 6 Typical 3300 XL NSv 5 m Proximitor Sensor with 4 m Extension Cable @ High Temperature (Probe is at 25°C)

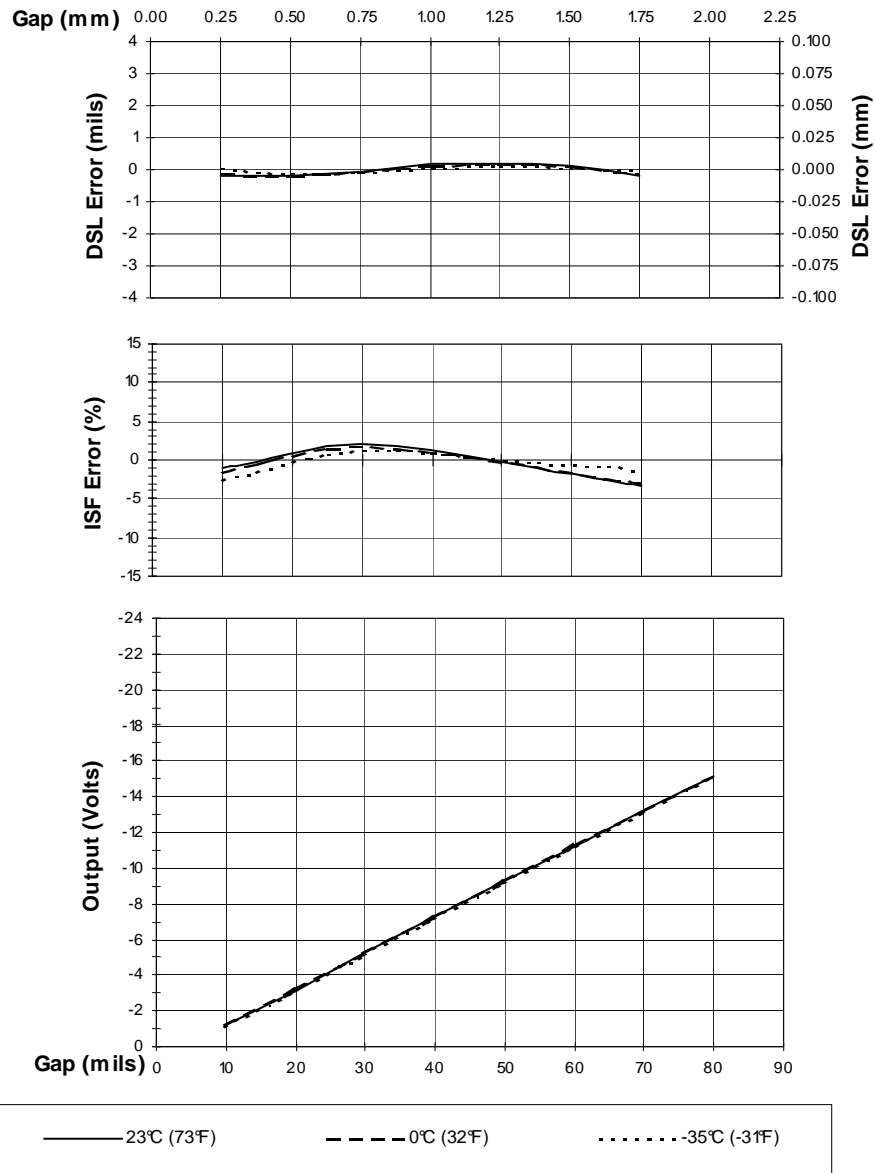

Figure 7 Typical 3300 XL NSv 7 m Proximity Sensor with 6 m of Extension Cable @ Low Temperature (Probe is at 25°C)

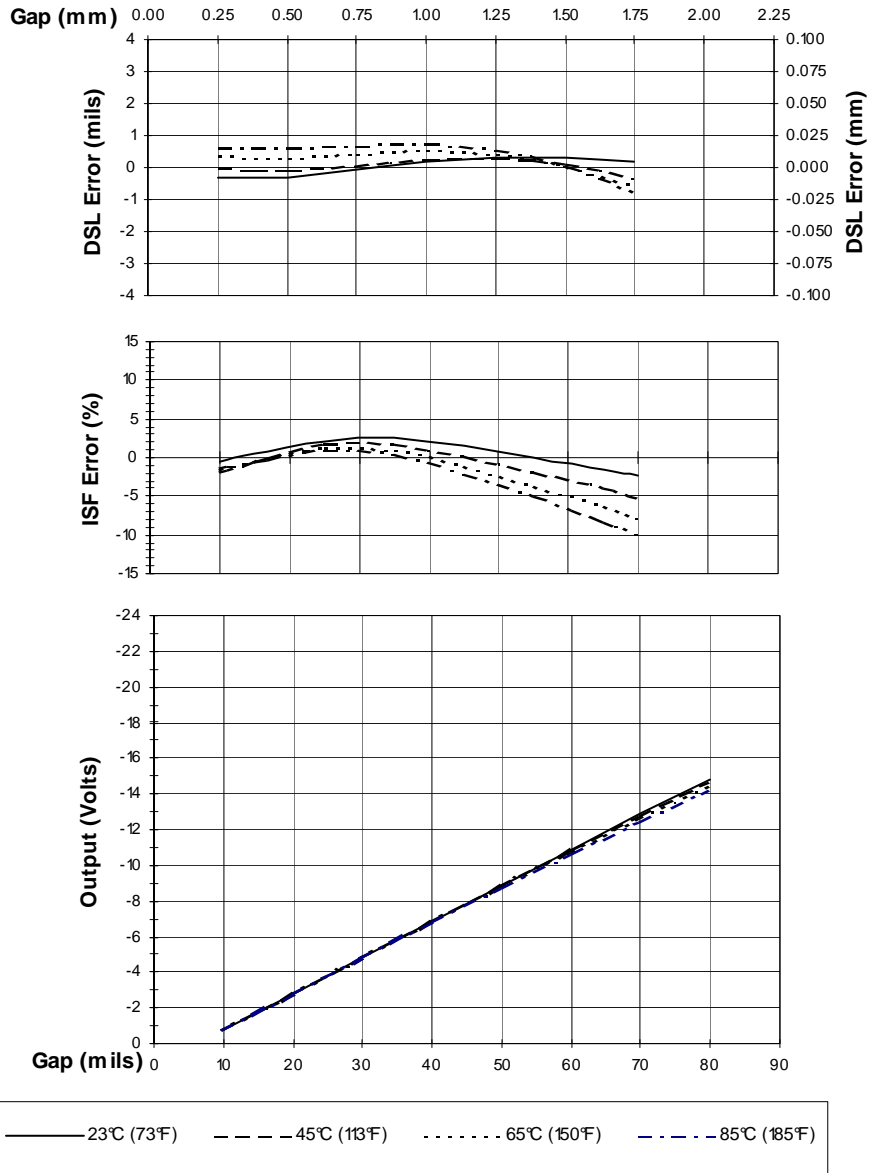

Figure 8 Typical 3300 XL NSv 7 m Proximity Sensor with 6 m of Extension Cable @ High Temperature (Probe is at 25°C)

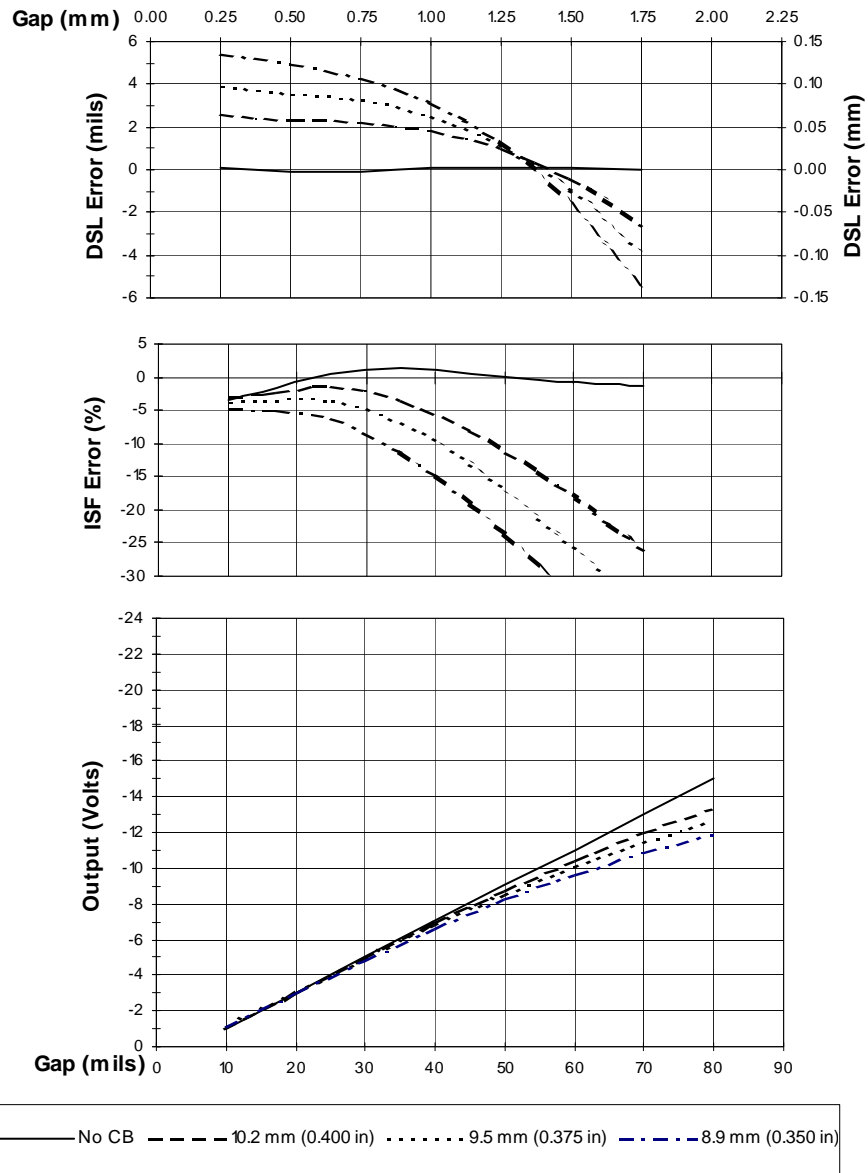

Figure 9 Effect of Counterbore Side Clearance (4140 Material)

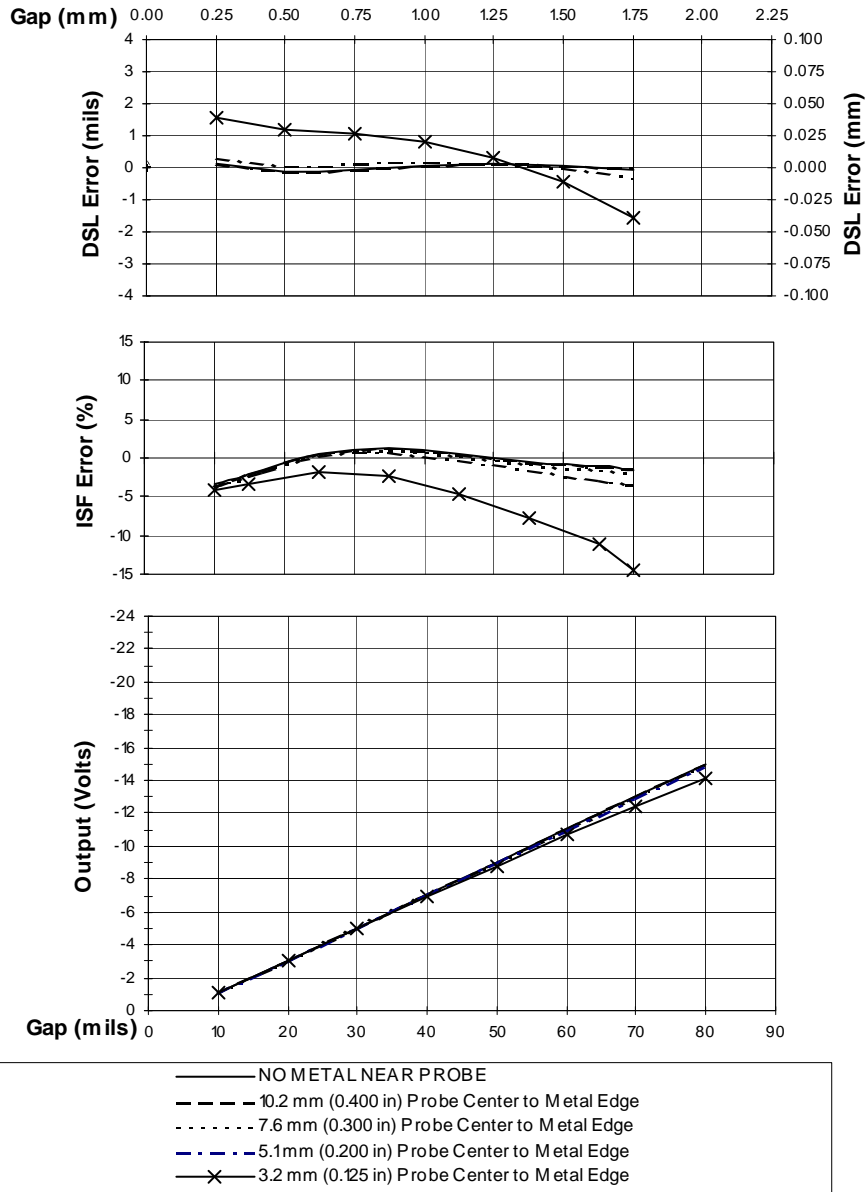

Figure 10 Effect of Flat Surface Side Clearance (4140 Material)

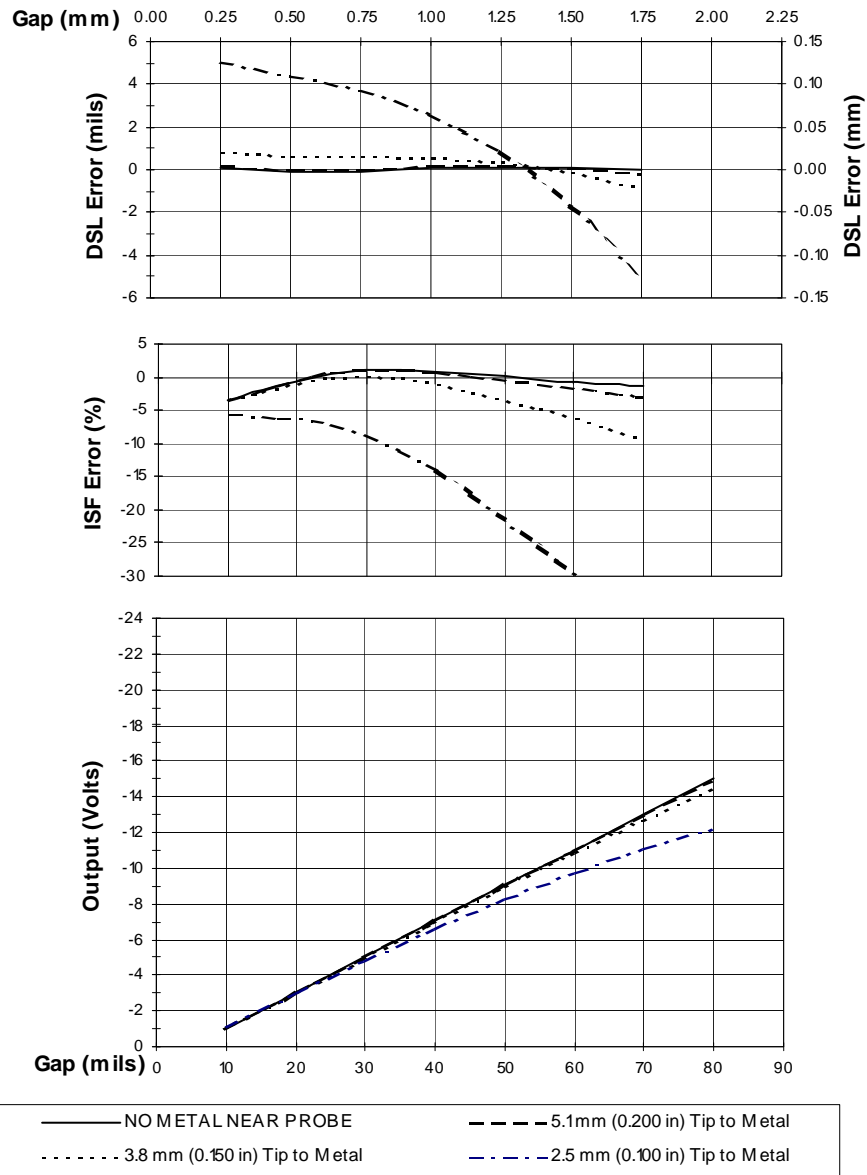

Figure 11 Effect of Rear Surface Clearance (4140 Material)

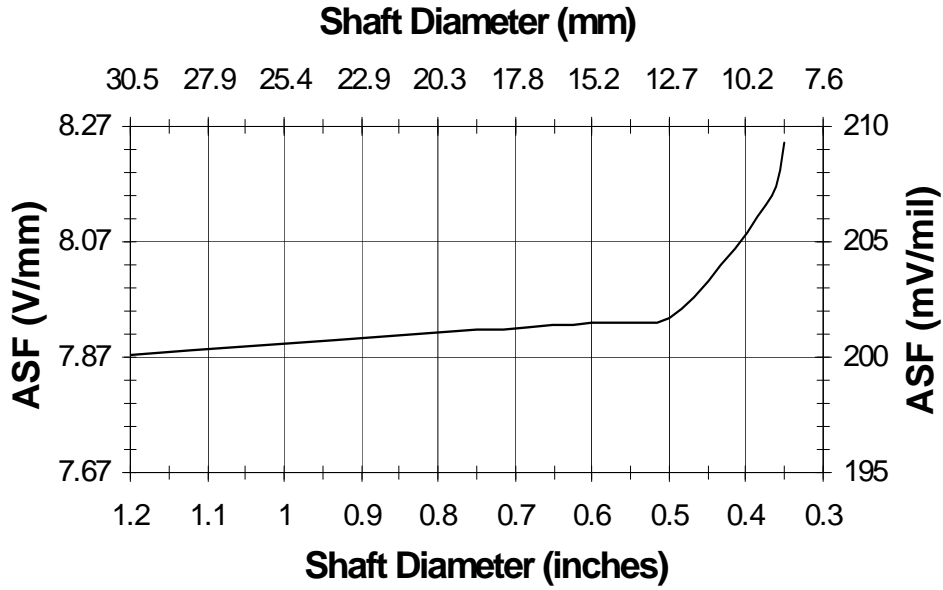

Figure 12 Axial Sensitivity to Shaft Size

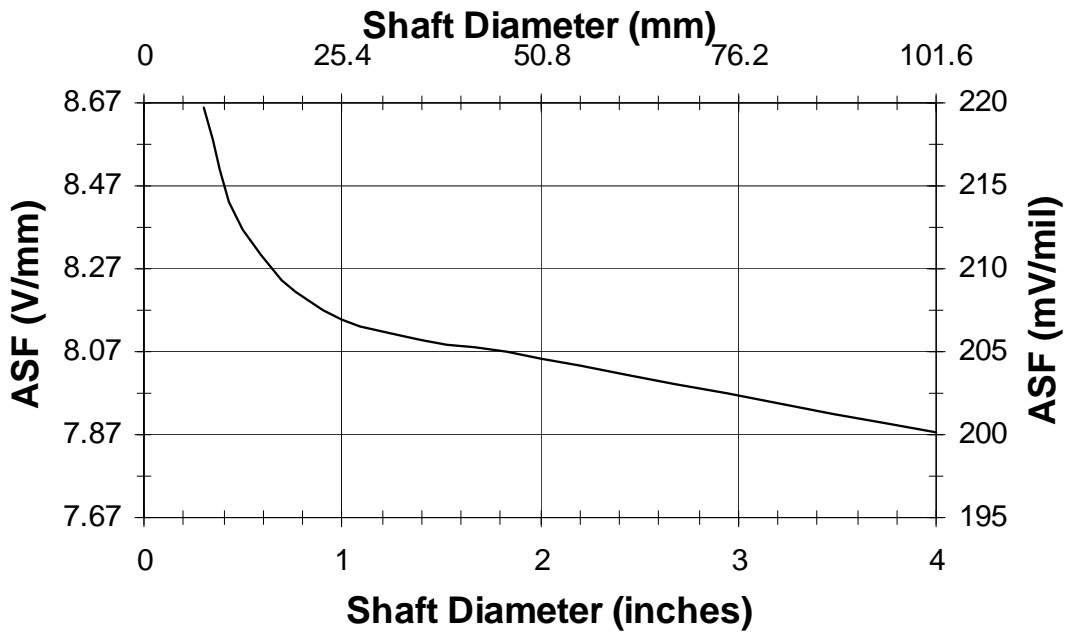

Figure 13 Radial Sensitivity to Shaft Size

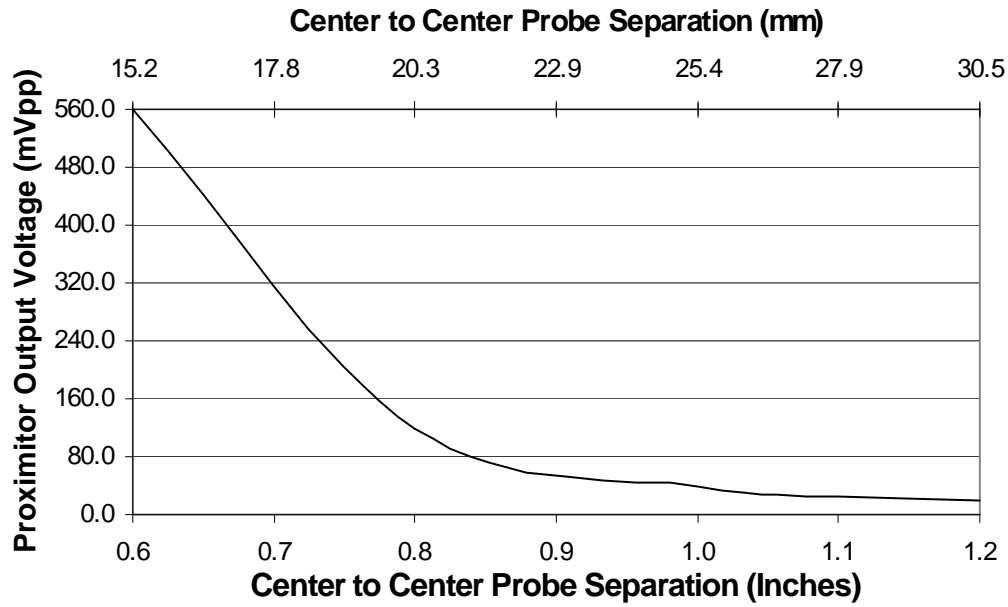

Figure 14 Probe Cross-talk with Probes Mounted in Parallel

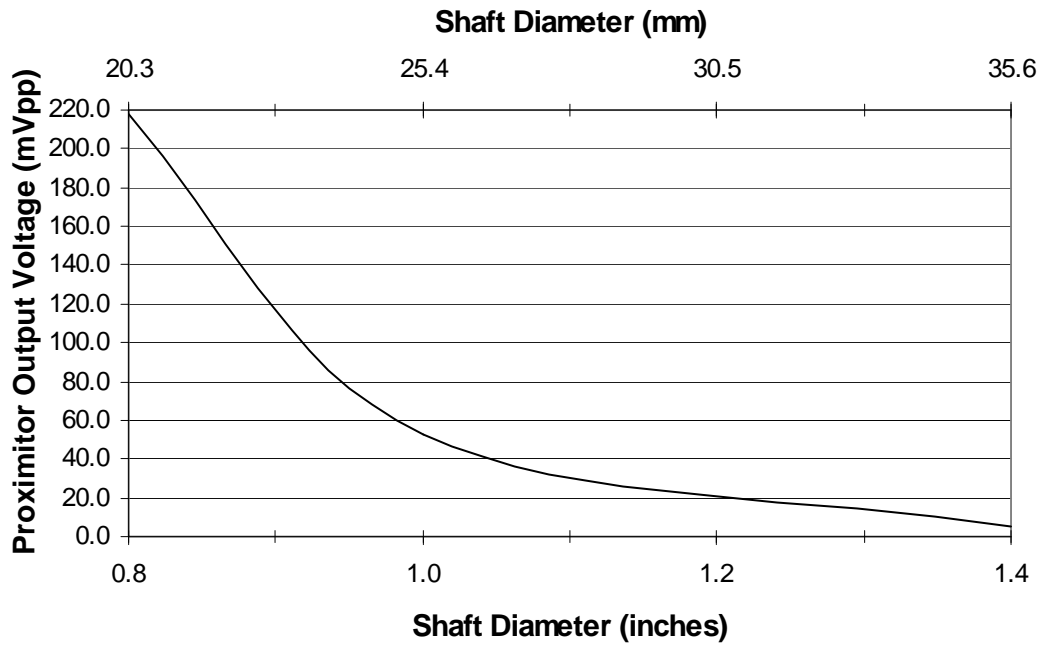

Figure 15 Probe Cross-talk with Probes Mounted in X-Y Configuration

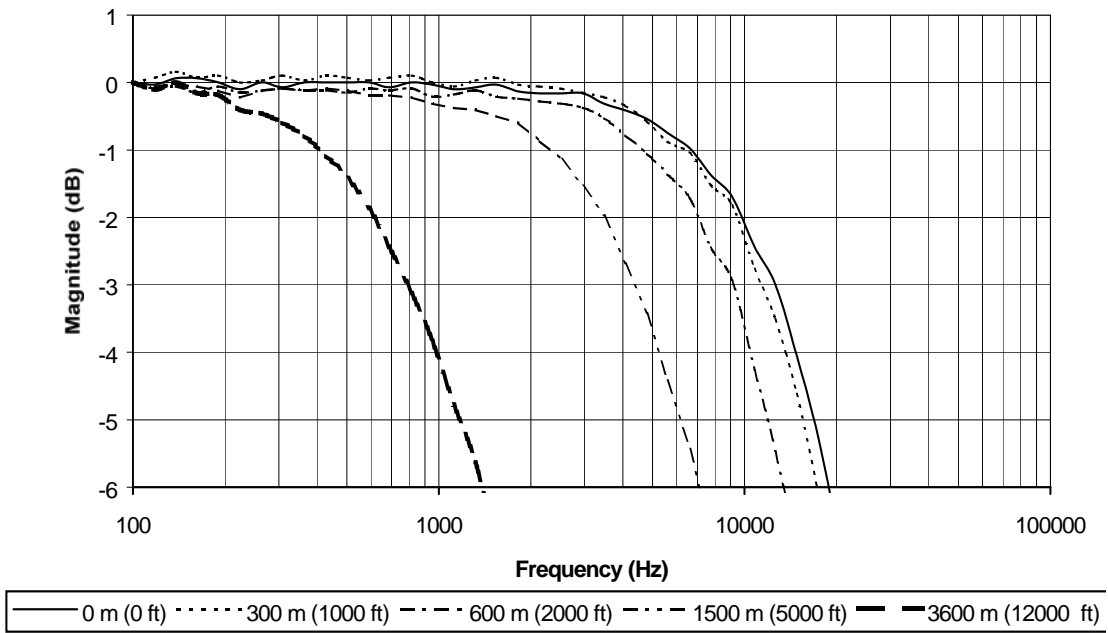

Figure 16 Frequency Response, magnitude of typical 3300 XL NSv System with various lengths of field wiring, no barriers

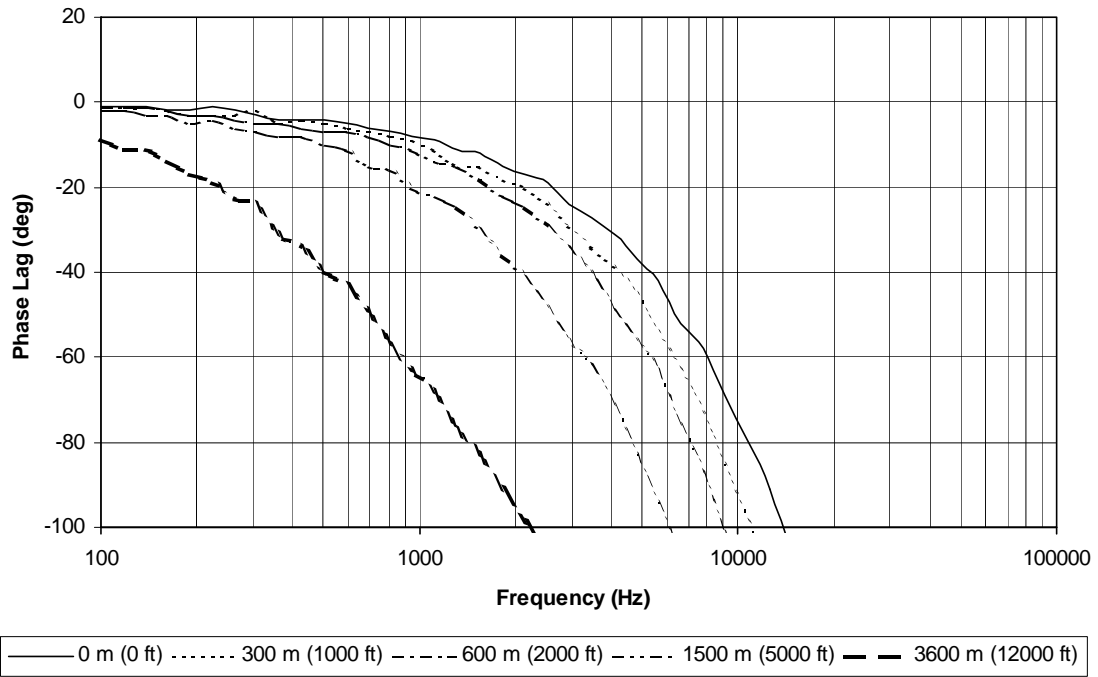

Figure 17 Frequency Response, phase change of typical 3300 XL NSv System with various lengths of field wiring, no barriers

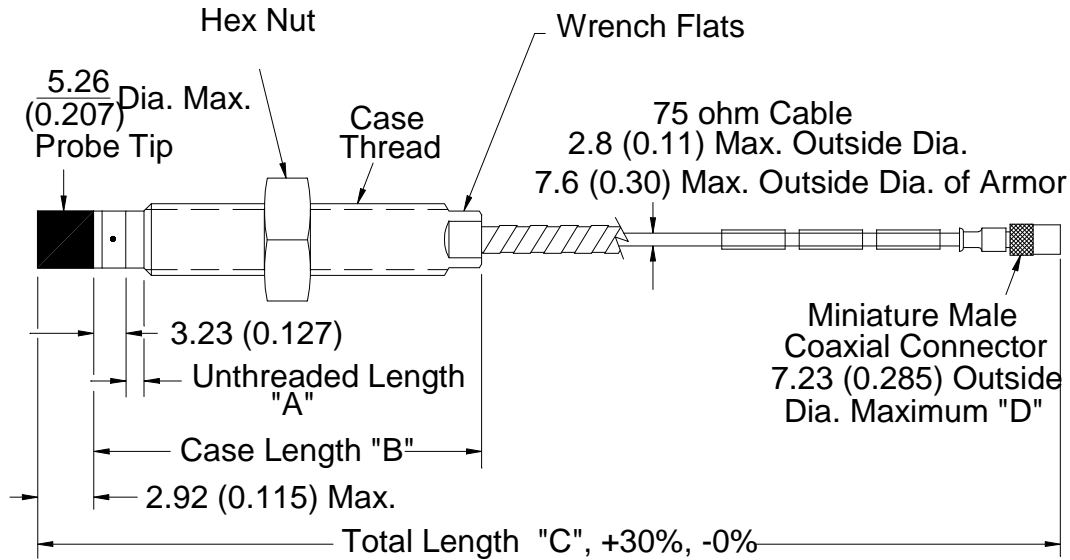

Figure 18 3300 NSv Proximity probes, Standard Mount

- 330901, ¼ -28 UNF-2A, without armor
- 330902, ¼ -28 UNF-2A, with armor
- 330903, M8x1 thread, without armor
- 330904, M8x1 thread, with armor
- 330905, M10x1 thread, without armor
- 330908, 3/8-24 UNF-2A, without armor
- 330909, 3/8-24 UNF 2A, with armor
- 330910, M10x1 thread, with armor

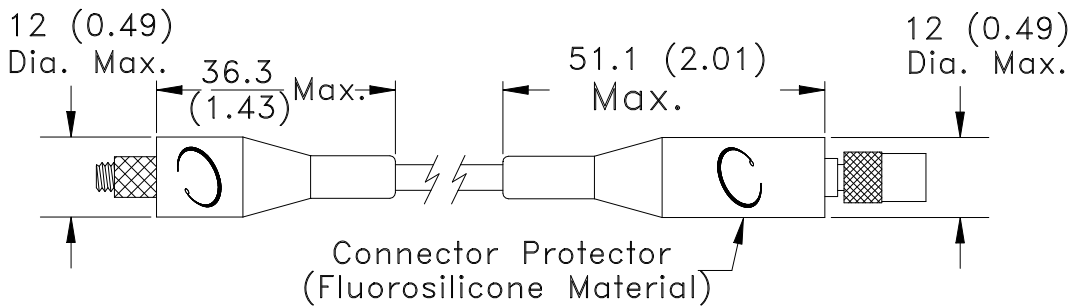

Figure 19 Installed Connector Protectors

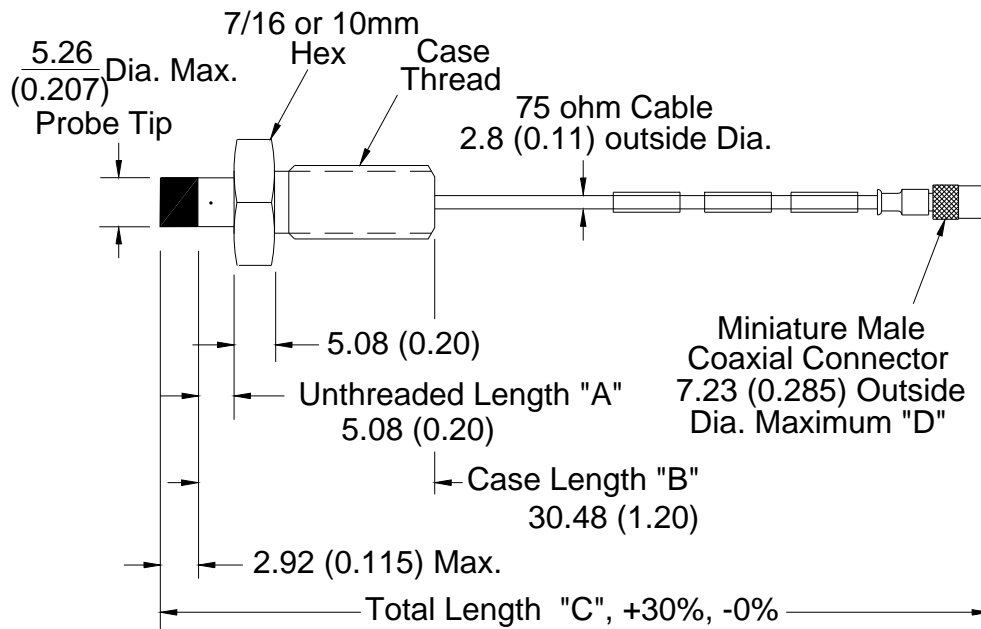

Figure 20 3300 NSv Proximity Probes, Reverse Mount

330906, 3/8-24 UNF-2A threads

330907, M10x1 threads

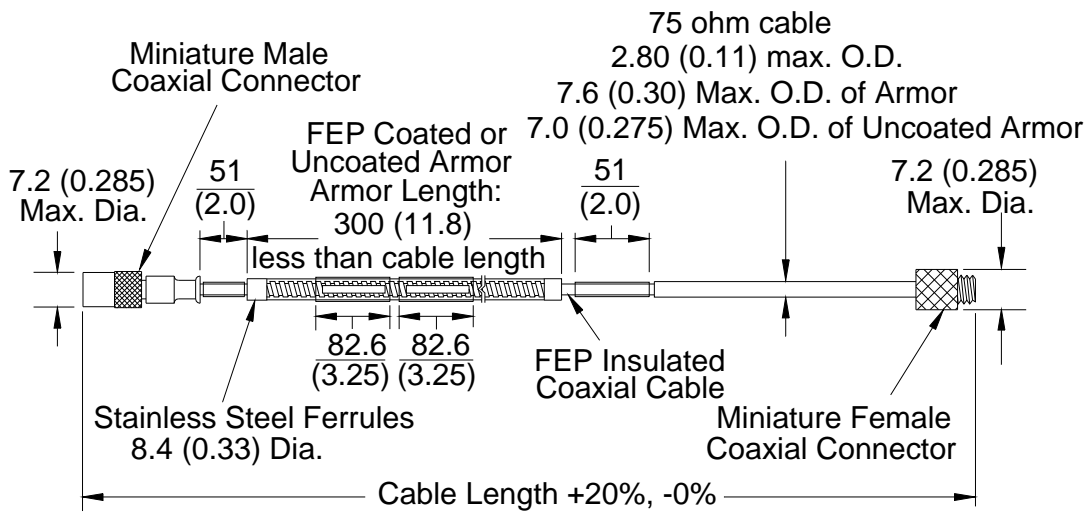

Figure 21 330930, 3300 NSv Extension Cable

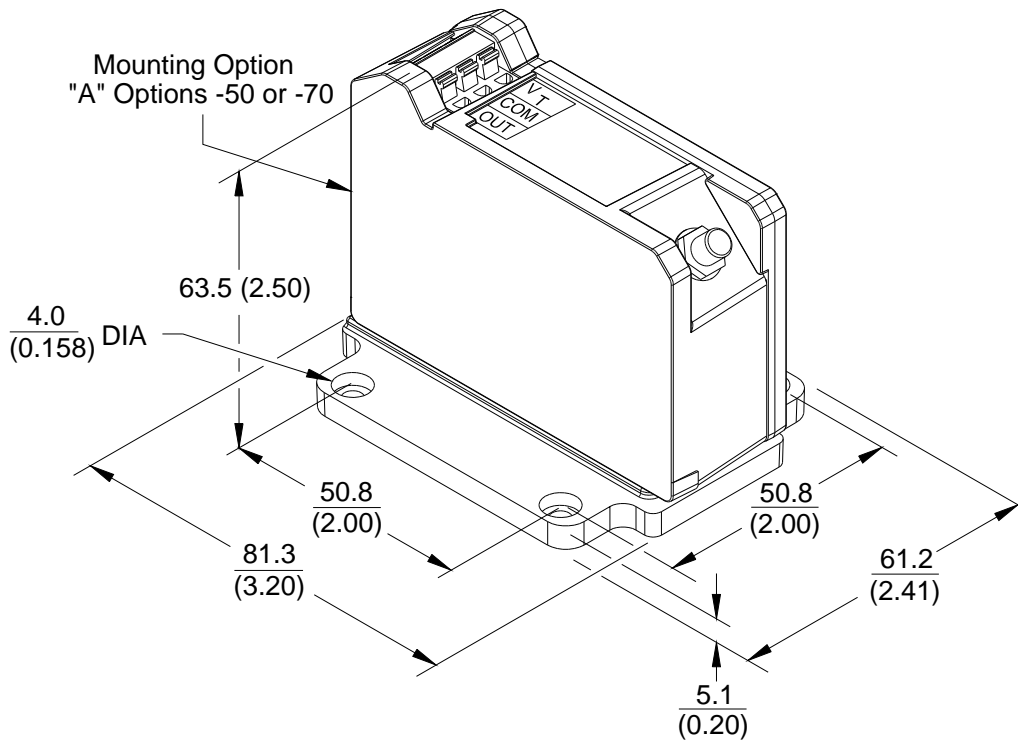

Figure 22 Panel Mount 3300 XL NSv Proximity Sensor

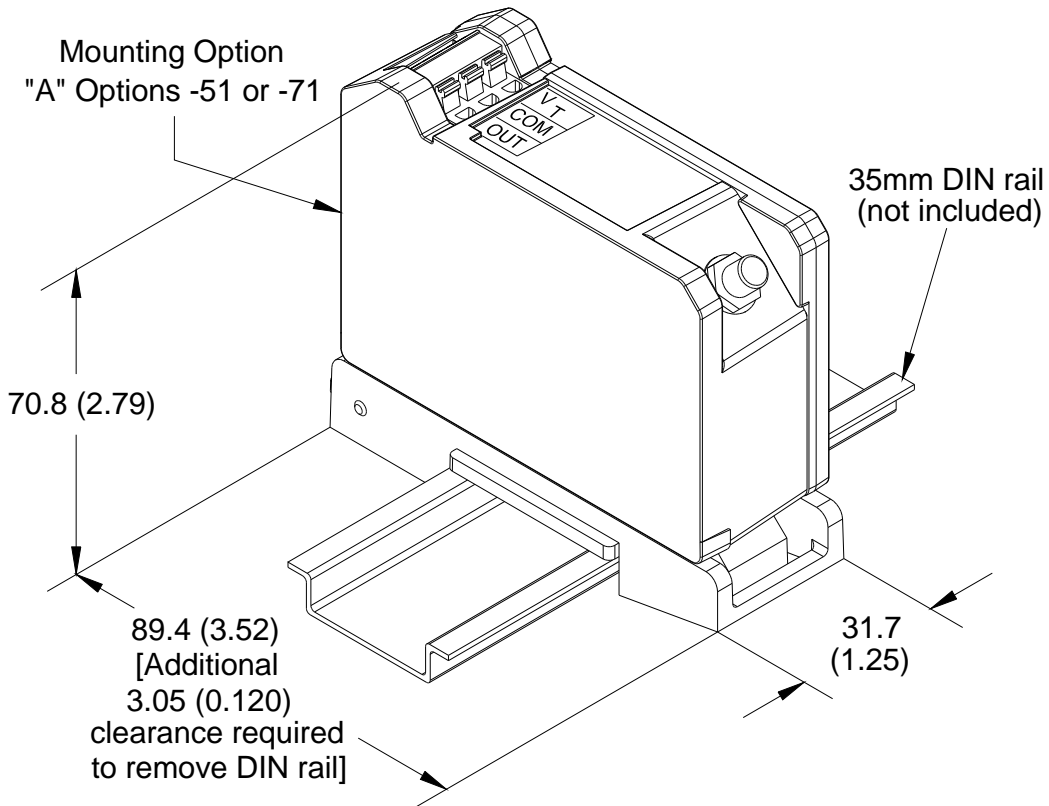

Figure 23 DIN Mount 3300 XL NSv Proximity Sensor

Notes:

All dimensions on figures are in millimeters (inches) unless otherwise noted.

Standard mount $\frac{1}{4}$ -28 UNF thread probes are supplied with $\frac{7}{16}$ inch lock nut and $\frac{7}{32}$ wrench flats.

Standard mount M8x1 thread probes are supplied with 13 mm lock nut and 7 mm wrench flats.

Standard mount $\frac{3}{8}$ -24 UNF thread probes are supplied with $\frac{5}{16}$ inch lock nut and $\frac{5}{16}$ wrench flats.

Standard mount M10x1 thread probes are supplied with 17 mm lock nut and 8 mm wrench flats.

Reverse mount probes are not available with armor or connector protector options.

Letters inside quotation marks on figures refer to probe ordering options.

Stainless steel armor is supplied with or without FEP outer jacket.

FEP jacket is standard on all non-armored probes.

* Denotes a trademark of Bently Nevada, Inc., a wholly owned subsidiary of General Electric Company.
Viton® is a trademark of DuPont.

© 2001 – 2013 Bently Nevada, Inc. All rights reserved.

Printed in USA. Uncontrolled when transmitted electronically.

1631 Bently Parkway South, Minden, Nevada USA 89423

Phone: 775.782.3611 Fax: 775.215.2873

www.ge-mcs.com/bently