



Fail-safe reversing starter, 3RM1, 500 V, 0.09 - 0.75 kW, 0.4 - 2 A, 24 V DC, screw/spring-type terminals

product brand name	SIRIUS
product category	Motor starter
product designation	Failsafe reversing starters
design of the product	With electronic overload protection and safety-related disconnection
product type designation	3RM1
General technical data	
trip class	CLASS 10A
equipment variant acc. to IEC 60947-4-2	3
product function	fail-safe reversing starter
<ul style="list-style-type: none"> intrinsic device protection 	Yes
<ul style="list-style-type: none"> for power supply reverse polarity protection 	Yes
suitability for operation device connector 3ZY12	Yes
power loss [W] for rated value of the current at AC in hot operating state per pole	0.1 W
insulation voltage rated value	500 V
overvoltage category	III
surge voltage resistance rated value	6 kV
maximum permissible voltage for safe isolation	
<ul style="list-style-type: none"> between main and auxiliary circuit 	500 V
<ul style="list-style-type: none"> between control and auxiliary circuit 	250 V
shock resistance	6g / 11 ms
vibration resistance	1 ... 6 Hz, 15 mm; 20 m/s ² , 500 Hz
operating frequency maximum	1 1/s
mechanical service life (switching cycles) typical	15 000 000
reference code acc. to IEC 81346-2	Q
Substance Prohibitance (Date)	01.03.2017
product function	
<ul style="list-style-type: none"> direct start 	No
<ul style="list-style-type: none"> reverse starting 	Yes
product function short circuit protection	No
Electromagnetic compatibility	
EMC emitted interference acc. to IEC 60947-1	class A
EMC immunity acc. to IEC 60947-1	Class A
conducted interference	
<ul style="list-style-type: none"> due to burst acc. to IEC 61000-4-4 	3 kV / 5 kHz
<ul style="list-style-type: none"> due to conductor-earth surge acc. to IEC 61000-4-5 	4 kV signal lines 2 kV
<ul style="list-style-type: none"> due to conductor-conductor surge acc. to IEC 61000-4-5 	2 kV
<ul style="list-style-type: none"> due to high-frequency radiation acc. to IEC 61000-4-6 	10 V

field-based interference acc. to IEC 61000-4-3	10 V/m
electrostatic discharge acc. to IEC 61000-4-2	6 kV contact discharge / 8 kV air discharge
conducted HF interference emissions acc. to CISPR11	Class B for the domestic, business and commercial environments
field-bound HF interference emission acc. to CISPR11	Class B for the domestic, business and commercial environments
Safety related data	
safety device type acc. to IEC 61508-2	Type B
Safety Integrity Level (SIL) acc. to IEC 61508	3
SIL Claim Limit (subsystem) acc. to EN 62061	SILCL 3
performance level (PL) acc. to EN ISO 13849-1	e
category acc. to EN ISO 13849-1	4
stop category acc. to DIN EN 60204-1	0
Safe failure fraction (SFF)	99.4 %
average diagnostic coverage level (DCavg)	99 %
diagnostics test interval by internal test function maximum	600 s
function test interval maximum	1 y
failure rate [FIT]	
• at rate of recognizable hazardous failures (λ_{dd})	1 400 FIT
• at rate of non-recognizable hazardous failures (λ_{du})	16 FIT
PFHD with high demand rate acc. to EN 62061	0.00000002 1/h
PFDAvg with low demand rate acc. to IEC 61508	0.000018
MTTFd	75 y
hardware fault tolerance acc. to IEC 61508	1
T1 value for proof test interval or service life acc. to IEC 61508	20 y
safe state	Load circuit open
protection class IP on the front acc. to IEC 60529	IP20
touch protection on the front acc. to IEC 60529	finger-safe
OFF-delay time with safety-related request	
• when switched off via control inputs maximum	43 ms
• when switched off via supply voltage maximum	120 ms
hardware fault tolerance acc. to IEC 61508 relating to ATEX	0
PFDAvg with low demand rate acc. to IEC 61508 relating to ATEX	0.0005
PFHD with high demand rate acc. to EN 62061 relating to ATEX	0.00000005 1/h
Safety Integrity Level (SIL) acc. to IEC 61508 relating to ATEX	SIL2
T1 value for proof test interval or service life acc. to IEC 61508 relating to ATEX	3 y
Main circuit	
number of poles for main current circuit	3
design of the switching contact	Hybrid
adjustable current response value current of the current-dependent overload release	0.4 ... 2 A
minimum load [%]	20 %; from set rated current
type of the motor protection	solid-state
operating voltage rated value	48 ... 500 V
relative symmetrical tolerance of the operating voltage	10 %
operating frequency 1 rated value	50 Hz
operating frequency 2 rated value	60 Hz
relative symmetrical tolerance of the operating frequency	10 %
operational current	
• at AC at 400 V rated value	2 A
• at AC-3 at 400 V rated value	2 A
• at AC-53a at 400 V at ambient temperature 40 °C rated value	2 A
ampacity when starting maximum	16 A
operating power for 3-phase motors at 400 V at 50 Hz	0.09 ... 0.75 kW

Inputs/ Outputs	
input voltage at digital input	
<ul style="list-style-type: none"> • at DC rated value • with signal <0> at DC • for signal <1> at DC 	24 V 0 ... 5 V 15 ... 30
input current at digital input	
<ul style="list-style-type: none"> • for signal <1> at DC • with signal <0> at DC 	8 mA 1 mA
number of CO contacts for auxiliary contacts	1
operational current of auxiliary contacts at AC-15 at 230 V maximum	3 A
operational current of auxiliary contacts at DC-13 at 24 V maximum	1 A
Control circuit/ Control	
type of voltage of the control supply voltage	DC
control supply voltage at DC rated value	19.2 ... 30 V
relative negative tolerance of the control supply voltage at DC	20 %
relative positive tolerance of the control supply voltage at DC	25 %
control supply voltage 1 at DC rated value	24 V
operating range factor control supply voltage rated value at DC	
<ul style="list-style-type: none"> • initial value • full-scale value 	0.8 1.25
control current at DC	
<ul style="list-style-type: none"> • in standby mode of operation • when switching on • during operation 	13 mA 150 mA 57 mA
duration of inrush current peak at 24 V	85 ms
power loss [W] in auxiliary and control circuit	
<ul style="list-style-type: none"> • in switching state OFF <ul style="list-style-type: none"> — with bypass circuit • in switching state ON <ul style="list-style-type: none"> — with bypass circuit 	0.35 W 1.37 W
Response times	
ON-delay time	65 ... 76 ms
OFF-delay time	30 ... 43 ms
Power Electronics	
operational current	
<ul style="list-style-type: none"> • at 40 °C rated value • at 50 °C rated value • at 55 °C rated value • at 60 °C rated value 	2 A 2 A 2 A 2 A
Installation/ mounting/ dimensions	
mounting position	vertical, horizontal, standing (observe derating)
fastening method	screw and snap-on mounting onto 35 mm standard mounting rail
height	100 mm
width	22.5 mm
depth	141.6 mm
required spacing	
<ul style="list-style-type: none"> • with side-by-side mounting <ul style="list-style-type: none"> — forwards — backwards — upwards — downwards — at the side • for grounded parts <ul style="list-style-type: none"> — forwards — backwards — upwards 	0 mm 0 mm 50 mm 50 mm 0 mm 0 mm 0 mm 50 mm

— at the side	3.5 mm
— downwards	50 mm
Ambient conditions	
installation altitude at height above sea level maximum	4 000 m; For derating see manual
ambient temperature	
• during operation	-25 ... +60 °C
• during storage	-40 ... +70 °C
• during transport	-40 ... +70 °C
environmental category during operation acc. to IEC 60721	3K6 (no ice formation, only occasional condensation), 3C3 (no salt mist), 3S2 (sand must not get into the devices), 3M6
relative humidity during operation	10 ... 95 %
air pressure acc. to SN 31205	900 ... 1 060 hPa
Communication/ Protocol	
protocol is supported	
• PROFINET IO protocol	No
• PROFI-safe protocol	No
product function bus communication	No
protocol is supported AS-Interface protocol	No
Connections/ Terminals	
type of electrical connection	screw-type terminals for main circuit, spring-loaded terminals (push-in) for control circuit
• for main current circuit	screw-type terminals
• for auxiliary and control circuit	spring-loaded terminals (push-in)
wire length for motor unshielded maximum	100 m
type of connectable conductor cross-sections	
• for main contacts	
— solid	1x (0,5 ... 4 mm ²), 2x (0,5 ... 2,5 mm ²)
— finely stranded with core end processing	1x (0,5 ... 4 mm ²), 2x (0,5 ... 1,5 mm ²)
• at AWG cables for main contacts	1x (20 ... 12), 2x (20 ... 14)
connectable conductor cross-section for main contacts	
• solid or stranded	0.5 ... 4 mm ²
• finely stranded with core end processing	0.5 ... 4 mm ²
connectable conductor cross-section for auxiliary contacts	
• solid or stranded	0.5 ... 1.5 mm ²
• finely stranded with core end processing	0.5 ... 1 mm ²
• finely stranded without core end processing	0.5 ... 1.5 mm ²
type of connectable conductor cross-sections	
• for auxiliary contacts	
— solid	1x (0.5 ... 1.5 mm ²), 2x (0.5 ... 1.5 mm ²)
— finely stranded with core end processing	1x (0,5 ... 1,0 mm ²), 2x (0,5 ... 1,0 mm ²)
— finely stranded without core end processing	1x (0.5 ... 1.5 mm ²), 2x (0.5 ... 1.5 mm ²)
• at AWG cables for auxiliary contacts	1x (20 ... 16), 2x (20 ... 16)
AWG number as coded connectable conductor cross section	
• for main contacts	20 ... 12
• for auxiliary contacts	20 ... 16
UL/CSA ratings	
yielded mechanical performance [hp]	
• for single-phase AC motor	
— at 230 V rated value	0.125 hp
• for 3-phase AC motor	
— at 200/208 V rated value	0.333 hp
— at 220/230 V rated value	0.333 hp
— at 460/480 V rated value	0.75 hp
operating voltage at AC	
• according to UL rated value	480 V
• according to CSA rated value	400 V
Certificates/ approvals	



Functional Safety/Safety of Machinery

Declaration of Conformity

other

[Type Examination Certificate](#)



[Confirmation](#)

Further information

Information- and Downloadcenter (Catalogs, Brochures,...)

<https://www.siemens.com/ic10>

Industry Mall (Online ordering system)

<https://mall.industry.siemens.com/mall/en/en/Catalog/product?mfb=3RM1302-3AA04>

Cax online generator

<http://support.automation.siemens.com/WW/CAXorder/default.aspx?lang=en&mfb=3RM1302-3AA04>

Service&Support (Manuals, Certificates, Characteristics, FAQs,...)

<https://support.industry.siemens.com/cs/ww/en/ps/3RM1302-3AA04>

Image database (product images, 2D dimension drawings, 3D models, device circuit diagrams, EPLAN macros, ...)

http://www.automation.siemens.com/bilddb/cax_de.aspx?mfb=3RM1302-3AA04&lang=en

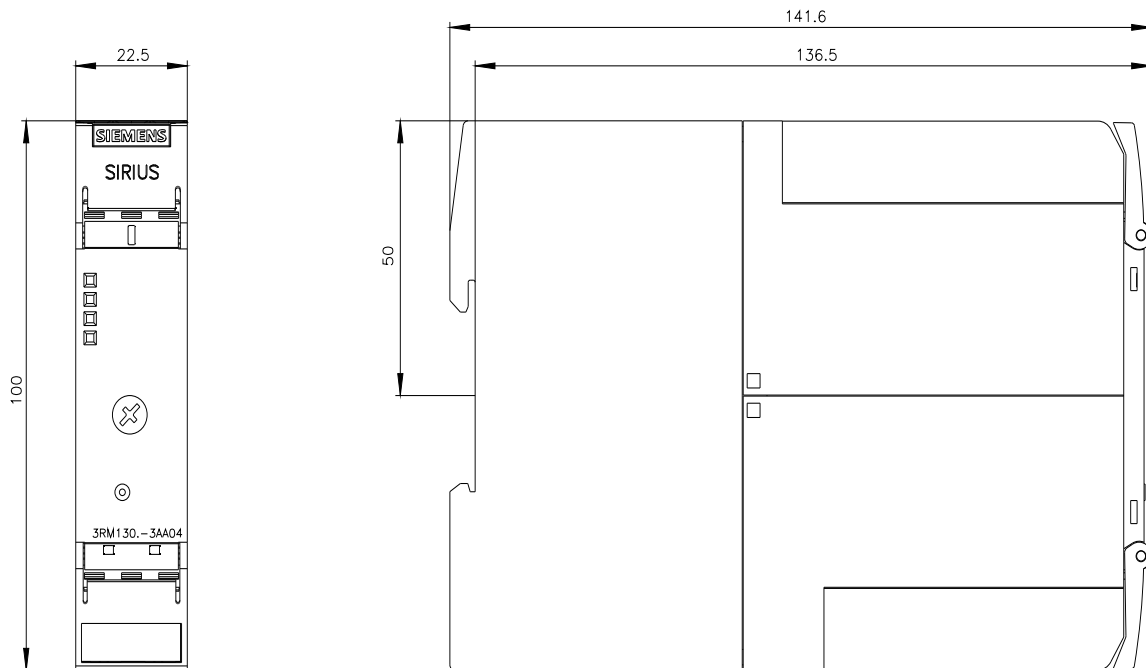

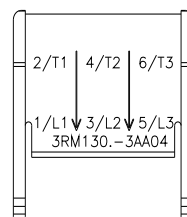
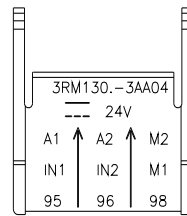
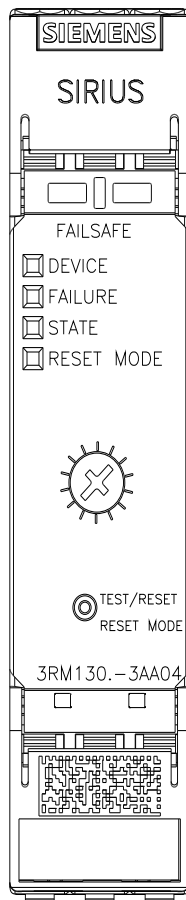
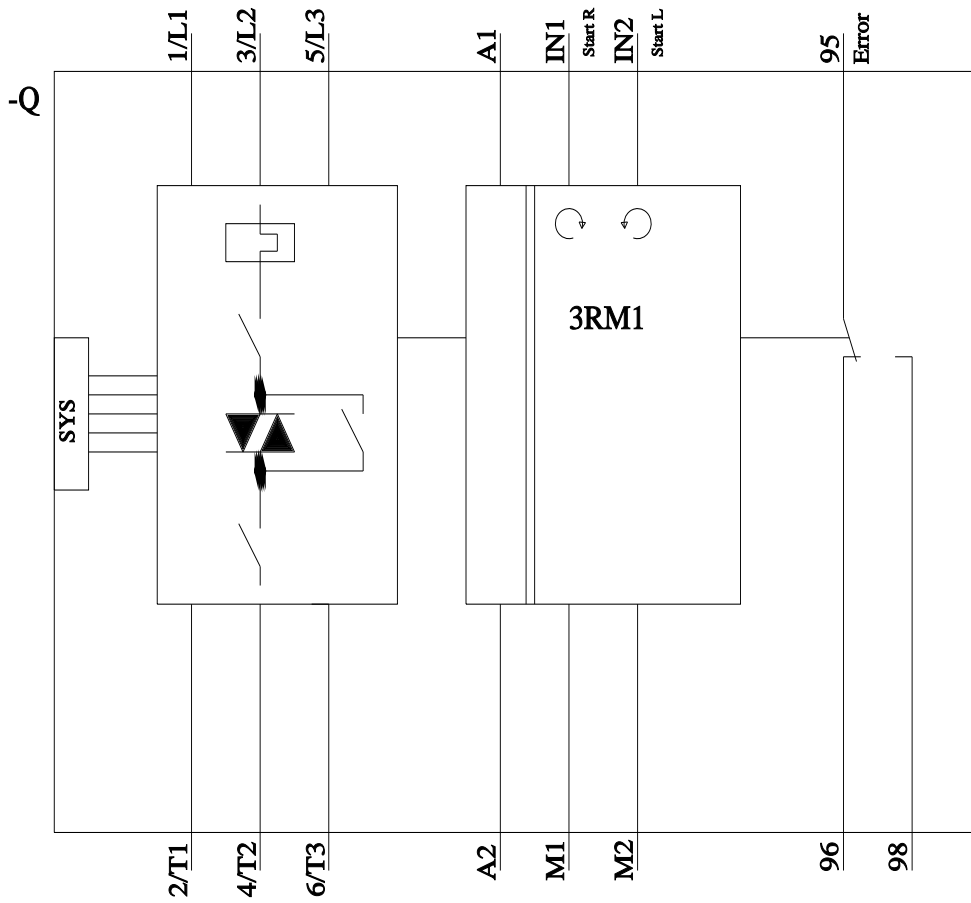

last modified:

11/3/2021