



Figure similar

SIRIUS soft starter 200-480 V 250 A, 110-250 V AC Screw terminals
Analog output

product brand name	SIRIUS
product category	Hybrid switching devices
product designation	Soft starter
product type designation	3RW50
manufacturer's article number	
<ul style="list-style-type: none"> • of standard HMI module usable • of high feature HMI module usable • of communication module PROFINET standard usable • of communication module PROFIBUS usable • of communication module Modbus TCP usable • of communication module Modbus RTU usable • of communication module Ethernet/IP • of circuit breaker usable at 400 V • of circuit breaker usable at 500 V • of the gG fuse usable up to 690 V • of full range R fuse link for semiconductor protection usable up to 690 V • of back-up R fuse link for semiconductor protection usable up to 690 V • of line contactor usable up to 480 V • of line contactor usable up to 690 V 	<ul style="list-style-type: none"> 3RW5980-OHS01 3RW5980-OHF00 3RW5980-OCS00 3RW5980-OCP00 3RW5980-OCT00 3RW5980-OCR00 3RW5980-OCE00 3VA2440-7MN32-0AA0; Type of assignment 1, I_q = 65 kA 3VA2440-7MN32-0AA0; Type of assignment 1, I_q = 65 kA 2x3NA3354-6; Type of coordination 1, I_q = 65 kA 3NE1 331-0; Type of coordination 2, I_q = 65 kA 3NE3 335; Type of coordination 2, I_q = 65 kA 3RT1065 3RT1065
General technical data	
starting voltage [%]	30 ... 100 %
stopping voltage [%]	50 ... 50 %
start-up ramp time of soft starter	0 ... 20 s
ramp-down time of soft starter	0 ... 20 s
current limiting value [%] adjustable	130 ... 700 %
accuracy class acc. to IEC 61557-12	5 %
certificate of suitability	
<ul style="list-style-type: none"> • CE marking • UL approval • CSA approval 	<ul style="list-style-type: none"> Yes Yes Yes
product component is supported	
<ul style="list-style-type: none"> • HMI-Standard • HMI-High Feature 	<ul style="list-style-type: none"> Yes Yes
product feature integrated bypass contact system	Yes
number of controlled phases	2

trip class	CLASS 10A / 10E (preset) / 20E; acc. to IEC 60947-4-2
buffering time in the event of power failure	
• for main current circuit	100 ms
• for control circuit	100 ms
insulation voltage rated value	600 V
degree of pollution	3, acc. to IEC 60947-4-2
impulse voltage rated value	6 kV
blocking voltage of the thyristor maximum	1 600 V
service factor	1
reference code acc. to IEC 81346-2	Q
product function	
• ramp-up (soft starting)	Yes
• ramp-down (soft stop)	Yes
• Soft Torque	Yes
• adjustable current limitation	Yes
• pump ramp down	Yes
• intrinsic device protection	Yes
• motor overload protection	Yes; Electronic motor overload protection
• evaluation of thermistor motor protection	No
• auto-RESET	Yes
• manual RESET	Yes
• remote reset	Yes; By turning off the control supply voltage
• communication function	Yes
• operating measured value display	Yes; Only in conjunction with special accessories
• error logbook	Yes; Only in conjunction with special accessories
• via software parameterizable	No
• via software configurable	Yes
• PROFInergy	Yes; in connection with the PROFINET Standard communication module
• voltage ramp	Yes
• torque control	No
• analog output	Yes; 4 ... 20 mA (default) / 0 ... 10 V (parameterizable with High Feature HMI)
Power Electronics	
operational current	
• at 40 °C rated value	250 A
• at 50 °C rated value	220 A
• at 60 °C rated value	200 A
operating voltage	
• rated value	200 ... 480 V
relative negative tolerance of the operating voltage	-15 %
relative positive tolerance of the operating voltage	10 %
operating power for 3-phase motors	
• at 230 V at 40 °C rated value	75 kW
• at 400 V at 40 °C rated value	132 kW
Operating frequency 1 rated value	50 Hz
Operating frequency 2 rated value	60 Hz
relative negative tolerance of the operating frequency	-10 %
relative positive tolerance of the operating frequency	10 %
adjustable motor current	
• at rotary coding switch on switch position 1	100 A
• at rotary coding switch on switch position 2	110 A
• at rotary coding switch on switch position 3	120 A
• at rotary coding switch on switch position 4	130 A
• at rotary coding switch on switch position 5	140 A
• at rotary coding switch on switch position 6	150 A
• at rotary coding switch on switch position 7	160 A
• at rotary coding switch on switch position 8	170 A
• at rotary coding switch on switch position 9	180 A

<ul style="list-style-type: none"> • at rotary coding switch on switch position 10 • at rotary coding switch on switch position 11 • at rotary coding switch on switch position 12 • at rotary coding switch on switch position 13 • at rotary coding switch on switch position 14 • at rotary coding switch on switch position 15 • at rotary coding switch on switch position 16 • minimum 	190 A 200 A 210 A 220 A 230 A 240 A 250 A 100 A
minimum load [%]	15 %; Relative to smallest settable le
power loss [W] for rated value of the current at AC	
<ul style="list-style-type: none"> • at 40 °C after startup • at 50 °C after startup • at 60 °C after startup 	23 W 18 W 15 W
power loss [W] at AC at current limitation 350 %	
<ul style="list-style-type: none"> • at 40 °C during startup • at 50 °C during startup • at 60 °C during startup 	2 454 W 2 043 W 1 786 W
type of the motor protection	Electronic, tripping in the event of thermal overload of the motor
Control circuit/ Control	
type of voltage of the control supply voltage	AC
<ul style="list-style-type: none"> • control supply voltage at AC at 50 Hz • control supply voltage at AC at 60 Hz 	110 ... 250 V 110 ... 250 V
relative negative tolerance of the control supply voltage at AC at 50 Hz	-15 %
relative positive tolerance of the control supply voltage at AC at 50 Hz	10 %
relative negative tolerance of the control supply voltage at AC at 60 Hz	-15 %
relative positive tolerance of the control supply voltage at AC at 60 Hz	10 %
control supply voltage frequency	50 ... 60 Hz
relative negative tolerance of the control supply voltage frequency	-10 %
relative positive tolerance of the control supply voltage frequency	10 %
control supply current in standby mode rated value	30 mA
holding current in bypass operation rated value	105 mA
locked-rotor current at close of bypass contact maximum	2.2 A
inrush current peak at application of control supply voltage maximum	12.2 A
duration of inrush current peak at application of control supply voltage	2.2 ms
design of the overvoltage protection	Varistor
design of short-circuit protection for control circuit	4 A gG fuse (I _{cu} =1 kA), 6 A quick-acting fuse (I _{cu} =1 kA), C1 miniature circuit breaker (I _{cu} = 600 A), C6 miniature circuit breaker (I _{cu} = 300 A); Is not part of scope of supply
Inputs/ Outputs	
number of digital inputs	1
number of inputs for thermistor connection	0
number of digital outputs	3
<ul style="list-style-type: none"> • not parameterizable 	2
digital output version	2 normally-open contacts (NO) / 1 changeover contact (CO)
number of analog outputs	1
Installation/ mounting/ dimensions	
mounting position	with vertical mounting surface +/-90° rotatable, with vertical mounting surface +/- 22.5° tiltable to the front and back
fastening method	screw fixing
height	230 mm
width	160 mm
depth	282 mm

required spacing with side-by-side mounting	
<ul style="list-style-type: none"> • forwards • backwards • upwards • downwards • at the side 	<p>10 mm</p> <p>0 mm</p> <p>100 mm</p> <p>75 mm</p> <p>5 mm</p>
weight without packaging	7.3 kg
Connections/ Terminals	
type of electrical connection	
<ul style="list-style-type: none"> • for main current circuit • for control circuit 	<p>busbar connection</p> <p>screw-type terminals</p>
width of connection bar maximum	45 mm
type of connectable conductor cross-sections	
<ul style="list-style-type: none"> • for main contacts for box terminal using the front clamping point solid 	95 ... 300 mm ²
<ul style="list-style-type: none"> • for main contacts for box terminal using the front clamping point finely stranded with core end processing 	70 ... 240 mm ²
<ul style="list-style-type: none"> • for main contacts for box terminal using the front clamping point finely stranded without core end processing 	70 ... 240 mm ²
<ul style="list-style-type: none"> • for main contacts for box terminal using the front clamping point stranded 	95 ... 300 mm ²
<ul style="list-style-type: none"> • at AWG cables for main contacts for box terminal using the front clamping point 	3/0 ... 600 kcmil
<ul style="list-style-type: none"> • for main contacts for box terminal using the back clamping point solid 	120 ... 240 mm ²
<ul style="list-style-type: none"> • at AWG cables for main contacts for box terminal using the back clamping point 	250 ... 500 kcmil
<ul style="list-style-type: none"> • for main contacts for box terminal using both clamping points solid 	min. 2x 70 mm ² , max. 2x 240 mm ²
<ul style="list-style-type: none"> • for main contacts for box terminal using both clamping points finely stranded with core end processing 	min. 2x 50 mm ² , max. 2x 185 mm ²
<ul style="list-style-type: none"> • for main contacts for box terminal using both clamping points finely stranded without core end processing 	min. 2x 50 mm ² , max. 2x 185 mm ²
<ul style="list-style-type: none"> • for main contacts for box terminal using both clamping points stranded 	min. 2x 70 mm ² , max. 2x 240 mm ²
<ul style="list-style-type: none"> • for main contacts for box terminal using the back clamping point finely stranded with core end processing 	120 ... 185 mm ²
<ul style="list-style-type: none"> • for main contacts for box terminal using the back clamping point finely stranded without core end processing 	120 ... 185 mm ²
<ul style="list-style-type: none"> • for main contacts for box terminal using the back clamping point stranded 	120 ... 240 mm ²
type of connectable conductor cross-sections	
<ul style="list-style-type: none"> • at AWG cables for main current circuit solid 	2/0 ... 500 kcmil
<ul style="list-style-type: none"> • for DIN cable lug for main contacts stranded 	50 ... 240 mm ²
<ul style="list-style-type: none"> • for DIN cable lug for main contacts finely stranded 	70 ... 240 mm ²
type of connectable conductor cross-sections	
<ul style="list-style-type: none"> • for control circuit solid 	1x (0.5 ... 4.0 mm ²), 2x (0.5 ... 2.5 mm ²)
<ul style="list-style-type: none"> • for control circuit finely stranded with core end processing 	1x (0.5 ... 2.5 mm ²), 2x (0.5 ... 1.5 mm ²)
<ul style="list-style-type: none"> • at AWG cables for control circuit solid 	1x (20 ... 12), 2x (20 ... 14)
wire length	
<ul style="list-style-type: none"> • between soft starter and motor maximum 	800 m
<ul style="list-style-type: none"> • at the digital inputs at AC maximum 	1 000 m
tightening torque	
<ul style="list-style-type: none"> • for main contacts with screw-type terminals 	14 ... 24 N·m
<ul style="list-style-type: none"> • for auxiliary and control contacts with screw-type terminals 	0.8 ... 1.2 N·m

tightening torque [lbf·in]	
<ul style="list-style-type: none"> • for main contacts with screw-type terminals • for auxiliary and control contacts with screw-type terminals 	124 ... 210 lbf·in 7 ... 10.3 lbf·in
Ambient conditions	
installation altitude at height above sea level maximum	5 000 m; Derating as of 1000 m, see manual
<ul style="list-style-type: none"> • ambient temperature during operation 	-25 ... +60 °C; Please observe derating at temperatures of 40 °C or above
<ul style="list-style-type: none"> • ambient temperature during storage and transport 	-40 ... +80 °C
environmental category	
<ul style="list-style-type: none"> • during operation acc. to IEC 60721 	3K6 (no ice formation, only occasional condensation), 3C3 (no salt mist), 3S2 (sand must not get into the devices), 3M6
<ul style="list-style-type: none"> • during storage acc. to IEC 60721 	1K6 (only occasional condensation), 1C2 (no salt mist), 1S2 (sand must not get inside the devices), 1M4
<ul style="list-style-type: none"> • during transport acc. to IEC 60721 	2K2, 2C1, 2S1, 2M2 (max. fall height 0.3 m)
EMC emitted interference	acc. to IEC 60947-4-2: Class A
Communication/ Protocol	
communication module is supported	
<ul style="list-style-type: none"> • PROFINET standard 	Yes
<ul style="list-style-type: none"> • EtherNet/IP 	Yes
<ul style="list-style-type: none"> • Modbus RTU 	Yes
<ul style="list-style-type: none"> • Modbus TCP 	Yes
<ul style="list-style-type: none"> • PROFIBUS 	Yes
UL/CSA ratings	
manufacturer's article number	
<ul style="list-style-type: none"> • of circuit breaker <ul style="list-style-type: none"> — usable for High Faults at 460/480 V according to UL 	Siemens type: 3VA54, max. 600 A; Iq max = 65 kA
<ul style="list-style-type: none"> • of the fuse <ul style="list-style-type: none"> — usable for Standard Faults up to 575/600 V according to UL — usable for High Faults up to 575/600 V according to UL 	Type: Class L, max. 800 A; Iq = 18 kA Type: Class L, max. 800 A; Iq = 100 kA
operating power [hp] for 3-phase motors	
<ul style="list-style-type: none"> • at 200/208 V at 50 °C rated value 	60 hp
<ul style="list-style-type: none"> • at 220/230 V at 50 °C rated value 	75 hp
<ul style="list-style-type: none"> • at 460/480 V at 50 °C rated value 	150 hp
Safety related data	
protection class IP on the front acc. to IEC 60529	IP00; IP20 with cover
touch protection on the front acc. to IEC 60529	finger-safe, for vertical contact from the front with cover
ATEX	
certificate of suitability	
<ul style="list-style-type: none"> • ATEX 	Yes
<ul style="list-style-type: none"> • IECEX 	Yes
hardware fault tolerance acc. to IEC 61508 relating to ATEX	0
PFDAvg with low demand rate acc. to IEC 61508 relating to ATEX	0.09
PFHD with high demand rate acc. to EN 62061 relating to ATEX	0.000009 1/h
Safety Integrity Level (SIL) acc. to IEC 61508 relating to ATEX	SIL1
T1 value for proof test interval or service life acc. to IEC 61508 relating to ATEX	3 y
Certificates/ approvals	
General Product Approval	For use in hazardous locations



Declaration of Conformity

Test Certificates

other



EG-Konf.

[Miscellaneous](#)

[Type Test
Certificates/Test
Report](#)

[Type Test
Certificates/Test
Report](#)

[Confirmation](#)

[Confirmation](#)

Further information

Information- and Downloadcenter (Catalogs, Brochures,...)

<https://www.siemens.com/ic10>

Industry Mall (Online ordering system)

<https://mall.industry.siemens.com/mall/en/en/Catalog/product?mlfb=3RW5073-6AB14>

Cax online generator

<http://support.automation.siemens.com/WW/CAXorder/default.aspx?lang=en&mlfb=3RW5073-6AB14>

Service&Support (Manuals, Certificates, Characteristics, FAQs,...)

<https://support.industry.siemens.com/cs/ww/en/ps/3RW5073-6AB14>

Image database (product images, 2D dimension drawings, 3D models, device circuit diagrams, EPLAN macros, ...)

http://www.automation.siemens.com/bilddb/cax_de.aspx?mlfb=3RW5073-6AB14&lang=en

Characteristic: Tripping characteristics, I^t, Let-through current

<https://support.industry.siemens.com/cs/ww/en/ps/3RW5073-6AB14/char>

Characteristic: Installation altitude

<http://www.automation.siemens.com/bilddb/index.aspx?view=Search&mlfb=3RW5073-6AB14&objecttype=14&gridview=view1>

Simulation Tool for Soft Starters (STS)

<https://support.industry.siemens.com/cs/ww/en/view/101494917>

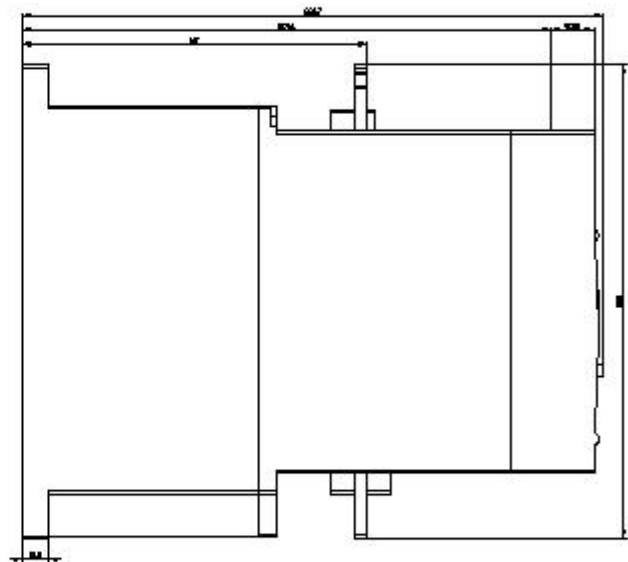
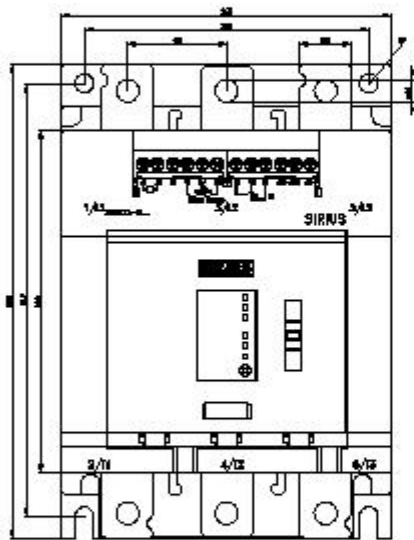

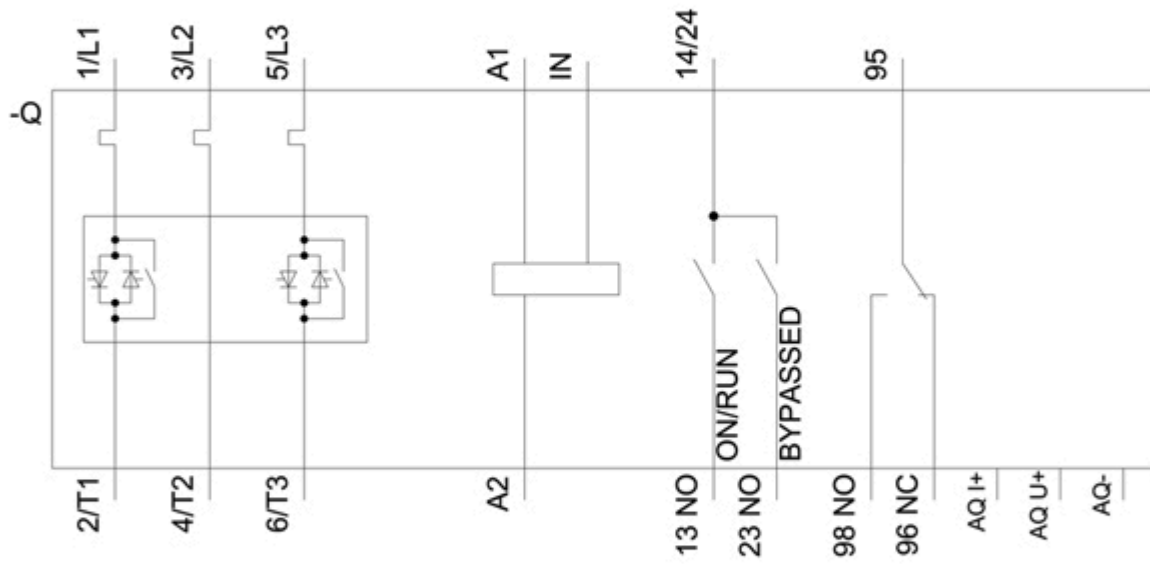

last modified:

12/15/2020 