

General Specifications

I/O Modules with Built-in Barrier (for FIO)



GS 33K50F80-50E

[Release 5]

■ GENERAL

This document describes about I/O Modules with Built-in Barrier (for FIO) which can be installed in Zone 2 or Division 2 and connected to devices located in Zone 0, 1, or Division 1.

These modules have galvanic isolation between the field interface and systems but they do not have isolation between channels.

These modules comply with ISA S71.04 class G3, and they can be located in the ambient temperature of -20 to 70 °C.

When connecting these modules to the intrinsically safe circuit, refer to documents "Explosion Protection" (TI 33Q01J30-01E) and "Explosion Protection of FIO Products" (IM 33Y06K01-90E) for CENELEC approval along with this General Specifications (GS).

Follow the EC-type Examination Certificate or FM certification for details of the rules and regulations of installing these modules in the intrinsically safe environment. It is especially important to follow the "Special Conditions" stated in these certificates.

In case these I/O modules with built-in barriers are to comply with FM approval (FM3610), install them on the following field control units (FCU), ESB bus node units, or ER bus node units equipped with power supply modules of PW481-11, PW482-11, or PW484-11.

<i>Field Control Units:</i>	<i>AFV10D-S41□11, AFV10S-S31□11, AFV10S-S41□11 AFV30D-S41□11, AFV30S-S31□11, AFV30S-S41□11</i>
<i>ESB Bus Node Units:</i>	<i>ANB10D-4□1, ANB10S-3□1, ANB10S-4□1 ANB10D-4□3, ANB10S-3□3, ANB10S-4□3</i>
<i>Optical ESB Bus Node Unit:</i>	<i>ANB11D-2□3, ANB11D-4□3 ANB11S-1□3, ANB11S-2□3, ANB11S-3□3, ANB11S-4□3</i>
<i>ER Bus Node Units:</i>	<i>ANR10D-4□3, ANR10S-3□3, ANR10S-4□3</i>

■ STANDARD SPECIFICATIONS

● Current Input Modules (Isolated)

Items		Specifications
Model		ASI133
Number of input channels		8, isolated
Input signal		4 to 20 mA
Allowable input current		22.5 mA
Withstanding voltage		1500 V AC
Input resistance	Power ON	For 2-wire: 400 Ω (I=20 mA) to 750 Ω (I=4 mA) For 4-wire: 485 Ω (I=20 mA) to 925 Ω (I=4 mA)
	Power OFF	1 MΩ or larger
Accuracy		±16 μA
Step response time		100 ms
Data update period		10 ms
Transmitter power supply		16 V DC or higher (output current limit: 20 mA)
Maximum normal mode input voltage applied to the terminals by 4-wire transmitter		25 V
Drift due to ambient temperature change		±16 μA/10 °C
Maximum current consumption		150 mA (5 V DC), 450 mA (24 V DC)
Weight		0.3 kg
External connection		Pressure clamp terminal (ATSA3□)
HART communication (*1)		Available
Barrier type		Isolated interface
Group, category ignition protection method		CENELEC: Ⓢ II (1) G D [EEx ia] II C (PTB 03 ATEX 2085) Ⓢ II 3 G EEx nA II T4 FM : Associated intrinsically safe apparatus for connection to Class I, II and III, Division 1, Groups A, B, C, D, E, F and G or Class I, Zone 0, Group II C Nonincendive for use in Class I, Division 2, Groups A, B, C, D, Temperature code T4

Note: When short circuits occur in two or more channels in the field, all channels of the module fails for intrinsic safety.

*1: When this module is installed to a ER bus node unit with HART function, the EB401 firmware must be rev. 2 or later.

● Current Output Modules (Isolated)

Items		Specifications
Model		ASI533
Number of output channels		8, isolated
Output signal		4 to 20 mA
Maximum output current		23 mA
Withstanding voltage		1500 V AC
Allowable load resistance		0 to 750 Ω at 20 mA, 0 to 600 Ω at 23 mA
Accuracy		±48 μA
Step response time		100 ms
Data update period		10 ms
Drift due to ambient temperature change		±16 μA/10 °C
Maximum current consumption		150 mA (5 V DC), 350 mA (24 V DC)
Weight		0.3 kg
External connection		Pressure clamp terminal (ATSS3□)
HART communication (*1)		Available
Barrier type		Isolated interface
Group, category ignition protection method		CENELEC: Ⓢ II (1) G D [EEx ia] II C (PTB 03 ATEX 2075) Ⓢ II 3 G EEx nA II T4 FM : Associated intrinsically safe apparatus for connection to Class I, II and III, Division 1, Groups A, B, C, D, E, F and G or Class I, Zone 0, Group II C Nonincendive for use in Class I, Division 2, Groups A, B, C, D, Temperature code T4

Note: When short circuits occur in two or more channels in the field, all channels of the module fails for intrinsic safety.

*1: When this module is installed to a ER bus node unit with HART function, the EB401 firmware must be rev. 2 or later.

● TC, mV Input/RTD/POT Input Modules (Isolated)

Items		Specifications	
Model		AST143 (*1) (*2)	ASR133 (*1)
Number of input channels		16, isolated	8, isolated
Input signal		TC: IEC60584-1995 Type B (*3), E, J, K, N, R, S, T mV: -100 to 150 mV, -50 to 75 mV	RTD: 2,3 and 4-wire type EN 60751: Pt50, Pt100, Pt200, Pt500, Pt1000 DIN 63760-1987: Ni100, Ni200 Minco standard: Ni120 POT: 3-wire type 0 to 10 kΩ
Switching input signal		TC/mV can be set individually for CH1 to CH16.	RTD/POT can be selected individually for CH1 to CH8.
Allowable input voltage		±5 V	±5 V
Withstanding voltage		1500 V AC	1500 V AC
Input resistance	Power ON	1 MΩ or larger	1 MΩ or larger
	Power OFF	1 MΩ or larger	1 MΩ or larger
Accuracy (at 23 °C)		TC: ±40 μV mV: ±80 μV	Pt50, Pt100, Ni100, Ni200, Ni120: ±150 mΩ Pt200: ±300 mΩ Pt500: ±600 mΩ Pt1000: ±1.2 Ω POT: ±2 Ω
Allowable total resistance of signal source plus wiring		1000 Ω or less	50 Ω per load (*4)
Effect of allowable signal source resistance (1000 Ω)		±20 μV	—
Reference junction compensation accuracy		±1 °C (*5) (*6)	—
Measurement current		—	150 μA
Temperature drift		TC: ±125 μV/10 °C mV: ±250 μV/10 °C	Pt50, Pt100, Ni100, Ni200, Ni120: ±325 mΩ/10 °C Pt200: ±650 mΩ/10 °C Pt500: ±1.3 Ω/10 °C Pt1000: ±2.6 Ω/10 °C POT: ±5.2 Ω/10 °C
Data update period		1 second or less	1 second or less
Burn-out		All channels can be set together. Setting : Not available/available (UP/DOWN)	
Maximum current consumption		150 mA (5 V DC), 80 mA (24 V DC)	150 mA (5 V DC), 60 mA (24 V DC)
Weight		0.3 kg	0.3 kg
External connection		Pressure clamp terminal (ATST4□)	Pressure clamp terminal (ATSR3□)
Barrier type		Isolated interface	Isolated interface
Group, category ignition protection method		CENELEC: Ⓢ II (1) G D [EEx ia] II C (PTB 03 ATEX 2062) Ⓢ II 3 G EEx nA II T4 FM : Associated intrinsically safe apparatus for connection to Class I, II and III, Division 1, Groups A, B, C, D, E, F and G or Class I, Zone 0, Group II C Nonincendive for use in Class I, Division 2, Groups A, B, C, D, Temperature code T4	CENELEC: Ⓢ II (1) G D [EEx ia] II C (PTB 03 ATEX 2076) Ⓢ II 3 G EEx nA II T4 FM : Associated intrinsically safe apparatus for connection to Class I, II and III, Division 1, Groups A, B, C, D, E, F and G or Class I, Zone 0, Group II C Nonincendive for use in Class I, Division 2, Groups A, B, C, D, Temperature code T4

*1: In order to satisfy the EMC requirements in accordance with the IEC 61000, use the shielded cable. (Shielded multi-core cable with one shield for all channel is sufficient.)

*2: Use a non-ground type thermocouple (TC) because AAT141 is an isolated type module. By connecting a ground type thermocouple (TC) to the module's multi-point channels, it becomes multi-point ground and causes a temperature error.

*3: Type B does not carry out temperature compensation and temperature under 44 °C is not measurable.

*4: Each wiring resistance must be equal.

*5: This figure varies depending on the installation conditions.
When the measured temperature is below 0 °C, multiply the following coefficient (K) with the above value.

$$K = \frac{\text{Thermoelectromotive force per degree at } 0\text{ }^{\circ}\text{C}}{\text{Thermoelectromotive force per degree at measured temperature}} \quad \text{F01E.ai}$$

*6: The reference junction compensation accuracy varies depending on the ambient temperature of the pressure clamp terminal.

For the node unit only

Ambient Temperature	Reference Junction Compensation Accuracy
-20 to 15 °C	±2 °C
15 to 45 °C	±1 °C
45 to 70 °C	±2 °C

● Digital Input Module

Items		Specifications
Model		ASD143
Number of input channels		16, isolated
Input Signal		NAMUR (IEC 60947-5-6) Compatible
Withstanding voltage		1500 V AC
Functions	Status input	Input response time: 15 ms
	Pushbutton input	Minimum ON detection time: 20 ms Maximum ON/OFF cycle: 25 Hz
Maximum current consumption		150 mA (5 V DC), 110 mA (24 V DC)
Weight		0.3 kg
External connection		Pressure clamp terminal (ATSB4□)
Barrier type		Isolated interface
Group, category ignition protection method		CENELEC: Ⓜ II (1) G D [EEx ia] II C (PTB 03 ATEX 2061) Ⓜ II 3 G EEx nA II T4 FM : Associated intrinsically safe apparatus for connection to Class I, II and III, Division 1, Groups A, B, C, D, E, F and G or Class I, Zone 0, Group II C Nonincendive for use in Class I, Division 2, Groups A, B, C, D, Temperature code T4

● Digital Output Module

Items		Specifications
Model		ASD533
Number of output channels		8, isolated
Output signal		12 V at I=40 mA, 26 V at I=0 mA
Withstanding voltage		1500 V AC
Functions		Status output
Output response time		10 ms
Maximum current consumption		150 mA (5 V DC), 500 mA (24 V DC)
Weight		0.3 kg
External connection		Pressure clamp terminal (ATSD3□)
Barrier type		Isolated interface
Group, category ignition protection method		CENELEC: Ⓜ II (1) G D [EEx ia] II C (PTB 03 ATEX 2074) Ⓜ II 3 G EEx nA II T4 FM : Associated intrinsically safe apparatus for connection to Class I, II and III, Division 1, Groups A, B, C, D, E, F and G or Class I, Zone 0, Group II C Nonincendive for use in Class I, Division 2, Groups A, B, C, D, Temperature code T4

Note: When short circuits occur in two or more channels in the field, all channels of the module fails for intrinsic safety.

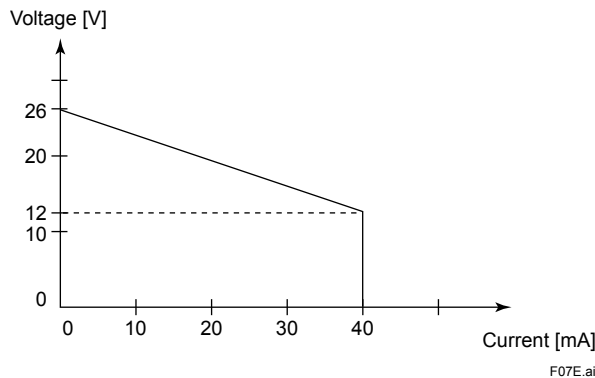

Figure Output Characteristics

Table List of Parameters (GENELEC) of Modules with Built-in Barrier

Modules		Uo (V)	Io (mA)	Po (mW)	Ui (V)	Co (nF)			Lo (mH)			Remarks (*1)
						IIC	IIB	IIA	IIC	IIB	IIA	
ASI133-S00 ASI133-H00	Single	27.8	84	584	-	84	659	659	2	18	18	2Wire
		27.8	4	28	28	84	659	659	100	100	100	4Wire
	Redundant	27.8	93	647	-	84	659	659	1.2	14	14	2Wire
		27.8	7	49	28	84	659	659	100	100	100	4Wire
ASI533-S00 ASI533-H00	Single	27.8	86	598	-	84	659	659	1.8	17	17	
	Redundant	27.8	93	647	-	84	659	659	1.2	14	14	
AST143-S00	Single	16.8	7	30	-	220	1730	8000	240	725	1930	No channel or one channel is connected to equipotential bonding.
		16.8	46	194	-	65	380	1550	5.6	22	44	Two channels up to all channels connected to equipotential bonding.
	Redundant	16.8	13	55	-	220	1730	8000	70	280	560	No channel or one channel is connected to equipotential bonding.
		16.8	92	387	-	65	380	1550	1.4	5.6	11	Two channels up to all channels connected to equipotential bonding.
ASR133-S00	Single	13.7	30	103	-	122	867	867	2.5	5	5	
	Redundant	13.7	60	206	-	94	714	714	1	5	5	
ASD143-P00	Single	9.8	21	52	-	1100	7600	11600	26	107	214	
	Redundant	9.8	41	101	-	1100	7600	11600	7	28	56	
ASD533-S00	Single	27.16	108.6	738	-	89	690	690	0.42	9.9	9.9	
	Redundant	27.16	108.6	738	-	89	690	690	0.42	9.9	9.9	

*1: These parameters are valid for the operation nodes of the corresponding modules if the model is not otherwise remarked.

Table List of Parameters (FM) of Modules with Built-in Barrier

Modules		Voc (V)	Isc (mA)	Po (mW)	Vmax (V)	Ca (nF)			La (mH)			Remarks (*1)
						A,B	C,E	D,F,G	A,B	C,E	D,F,G	
ASI133-S00 ASI133-H00	Single	27.8	84	584	-	84	659	659	2	18	18	2Wire
		27.8	4	28	28	84	659	659	100	100	100	4Wire
	Redundant	27.8	93	647	-	84	659	659	1.2	14	14	2Wire
		27.8	7	49	28	84	659	659	100	100	100	4Wire
ASI533-S00 ASI533-H00	Single	27.8	86	598	-	84	659	659	1.8	17	17	
	Redundant	27.8	93	647	-	84	659	659	1.2	14	14	
AST143-S00	Single	16.8	7	30	-	220	1730	8000	240	725	1930	No channel or one channel is connected to equipotential bonding.
		16.8	46	194	-	65	380	1550	5.6	22	44	Two channels up to all channels connected to equipotential bonding.
	Redundant	16.8	13	55	-	220	1730	8000	70	280	560	No channel or one channel is connected to equipotential bonding.
		16.8	92	387	-	65	380	1550	1.4	5.6	11	Two channels up to all channels connected to equipotential bonding.
ASR133-S00	Single	13.7	30	103	-	122	867	867	2.5	5	5	
	Redundant	13.7	60	206	-	94	714	714	1	5	5	
ASD143-P00	Single	9.8	21	52	-	1100	7600	11600	26	107	214	
	Redundant	9.8	41	101	-	1100	7600	11600	7	28	56	
ASD533-S00	Single	27.16	108.6	738	-	89	690	690	0.42	9.9	9.9	
	Redundant	27.16	108.6	738	-	89	690	690	0.42	9.9	9.9	

*1: These parameters are valid for the operation nodes of the corresponding modules if the model is not otherwise remarked.

■ OPERATING ENVIRONMENT

Hardware Requirements

The I/O modules run on the following FCS.

AFV10S, AFV10D,
AFV30S, AFV30D,
AFS30S, AFS30D, AFS40S, AFS40D,
AFG30S, AFG30D, AFG40S, AFG40D,
AFG81S, AFG81D, AFG82S, AFG82D, AFG83S, AFG83D, AFG84S, AFG84D,
AFF50S, and AFF50D

Software Requirements

The I/O modules run on the standard functions of the following FCS.

LFS1500 Control Function for Field Control Station (for AFV10□, Vnet/IP and FIO): for AFV10□
LFS1700 Control Function for Field Control Station (for AFV30□, Vnet/IP and FIO): for AFV30□
LFS1750 Node Expansion Package (for AFV30□/AFV40□)
LFS1300 Control Function for Standard Field Control Station (for V net and FIO): for AFS30□/AFS40□
LFS1330 Control Function for Enhanced Field Control Station (for V net and FIO):
for AFG30□/AFG40□ /AFG8□□
LFS1350 Control Function for Compact Field Control Station (for V net and FIO): for AFF50□

Engineering Requirements

Works on LHS5100/LHM5100 Standard Builder Function

■ ANALOG I/O MODULE WITH BUILT-IN BARRIER (WITH HART COMMUNICATION)

The analog I/O module (with HART communication function) connected to a transmitter or a valve positioner receives HART variable (*1) in addition to exchange analog input/output data by 4 – 20 mA signal with field control stations (FCS) .

*1: HART variable can be read by HART Command #3.

There are 2 types of analog I/O modules (with HART communication function).

Table Analog I/O Modules with Built-in Barrier (with HART Communication Function)

Model	Description	Function
ASI133-H	Analog input module with built-in barrier	4 – 20 mA, 8 channel, isolated
ASI533-H	Analog output module with built-in barrier	4 – 20 mA, 8 channel, isolated

● Communication with HART Devices

The analog I/O modules (with HART communication function) communicate with field devices and store analog data and HART variables in the Input/Output image area in the communication module. An FCS refers to and sets the Input/Output image by accessing the analog I/O modules (with HART communication function). The FCS utilizes the field device data via I/O terminals of the function block in the same way as other analog/digital I/O signals.

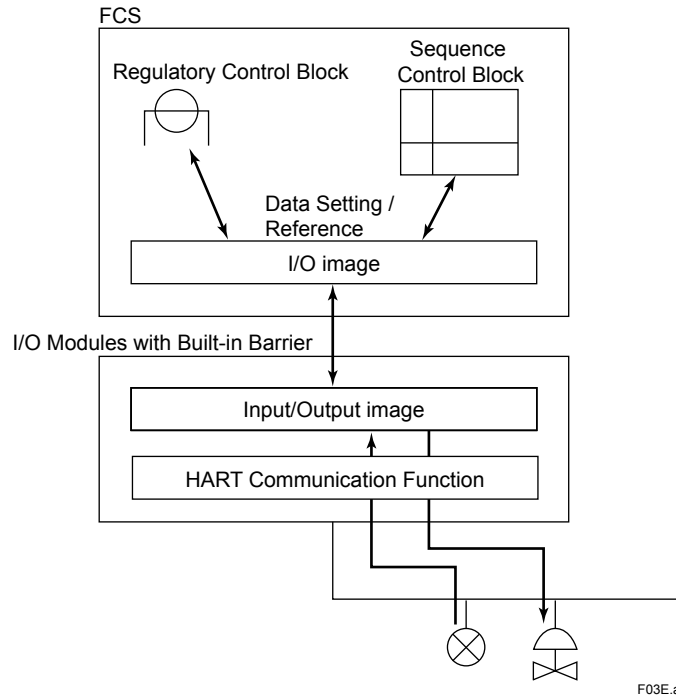

Figure Process Data Flow of HART Communication

● **HART Communication Functional Specifications**

The analog I/O modules (with HART communication function) are equipped with HART modems and enable HART communication (*1) by directly connecting the HART devices to the modules.

No. of HART devices: Max. 16 devices/module

HART variables: Max. 32 points/module

HART variables can be treated as ordinary process input data via %Z terminal connection. It is just for input.

HART multidrop connection (*2): Max. 5 devices/channel

HART variables data refresh cycle time :

1 second/device (When maximum of 16 devices are connected, it is 17 seconds per ESB bus connection and 19 seconds for ER bus connection.)

Analog data refresh cycle time (*3):

The number of ER bus node unit determines the analog data refresh cycle time in between the ER bus master interface module (EB401) and ER bus node units. With HART communication, it takes twice as much time than without HART communication.

	No. of ER bus node unit		
	2	4	6
Analog I/O (without HART communication)	50 ms	100 ms	200 ms
Analog I/O (with HART communication)	100 ms	200 ms	400 ms

*1: HART communication refers to HART variable communication, on-demand communication, and hand held terminal (HHT) communication.

*2: It is possible to connect only input devices. This connection does not support analog data value nor burst function.

*3: Field control units (AFV30□ and AFV40□) do not support ER bus node unit (ANR10□).

● **HART Communication Specifications**

Table HART Communication Specifications

Function	Description
Communication mode	Serial half-duplex, start-stop synchronization, 1 bit start/8 bit/odd number parity/1 bit stop
Applicable standard	HART Protocol Revision 5.7 (*1)
Transmission speed	1200 bps ± 1%
Modulation technique	Binary phase-continuous FSK 1: 1200 Hz ± 1%, 0: 2200 Hz ± 1%
Frame length	5 to 267 bytes Contents of max. 267 bytes Delimiter: 1 Address: 5 Command: 1 Byte count: 1 Data: 255 (including 2-byte response code) Check byte: 1
Frame detection	3-byte header byte-count carrier (ON/OFF) Preamble: 5 to 20 bytes
Error detection coding	Horizontal/vertical parity
Response time	Max. 28 characters (256.7 ms)
No response timer	Primary – 33 characters (305 ms) Secondary – 41 characters (380 ms)
Bus monitor	8 characters (75 ms)
Response window	20 ms

*1: The HART 5, 6, and 7 devices can be connected but applying the HART protocol 5.7 function.

● **HART Communication System Configuration**

The analog I/O modules (with HART communication function) can be configured dual-redundant by placing the two modules in the adjacent slots (odd number and even number slots) on the same node unit.

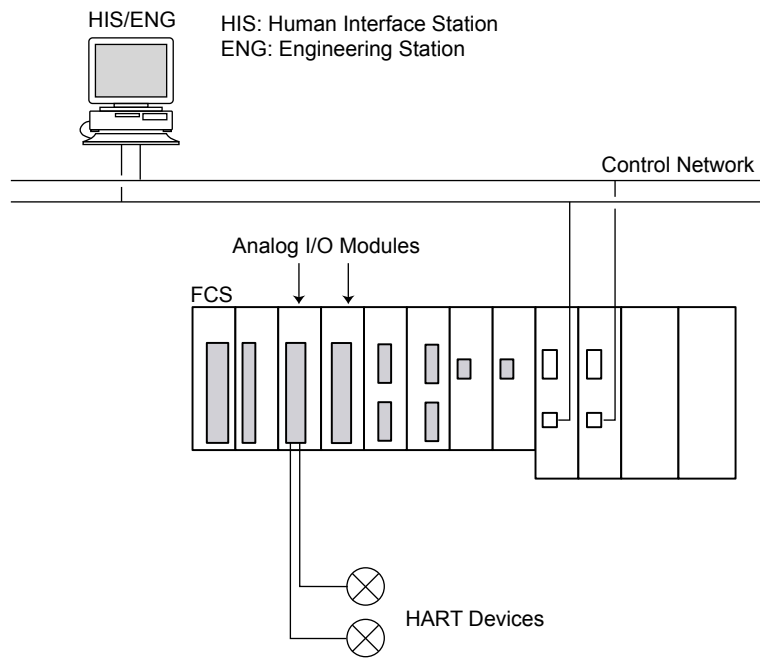

F04E.ai

Figure HART Communication System Configuration (Dual-redundant)

EXTERNAL DIMENSIONS

● ASD143 Modules with Barrier (for FIO)

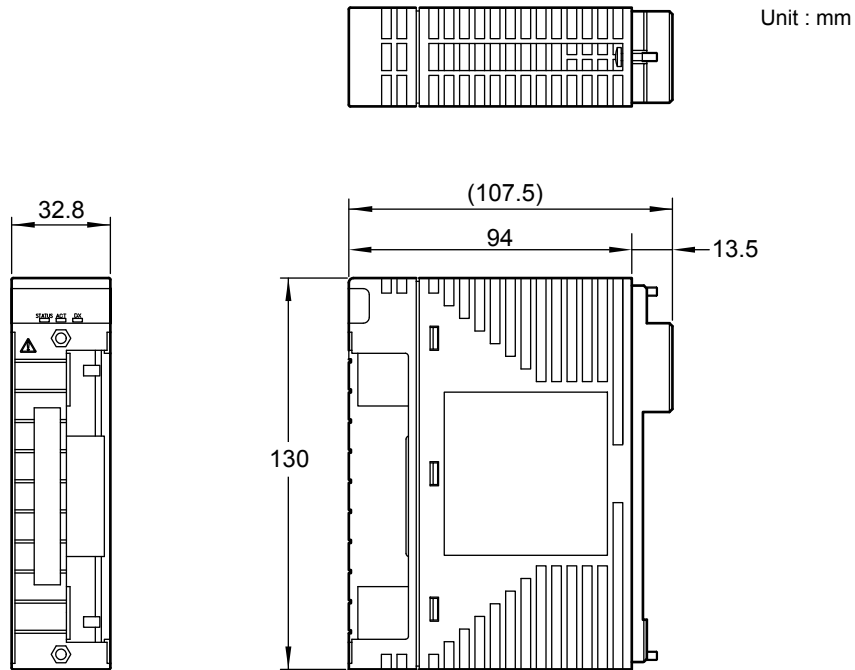

F05E.ai

● ASI133, ASI533, AST143, ASR133, ASD533

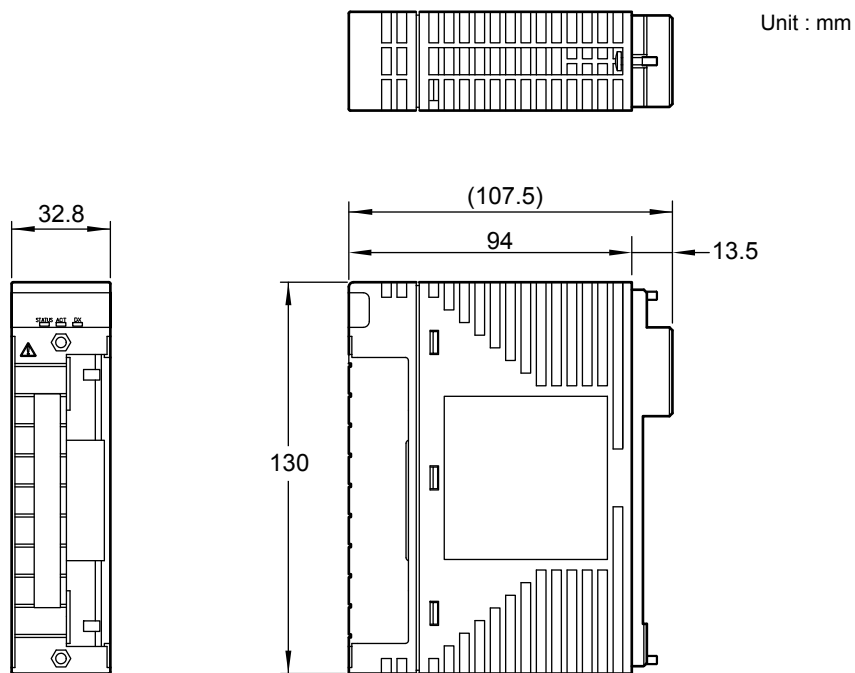

F06E.ai

■ MODELS AND SUFFIX CODES

● Analog I/O Module with Built-In Barrier

		Description
Model	ASI133	Analog Input Module with Built-In Barrier (4 to 20 mA, 8-channel, Isolated) (with ISA Standard G3 option and temperature (-20 to 70 °C) option)
Suffix Codes	-S	Standard type
	-H	With HART Communication
	0	Always 0
	0	Always 0
Option Codes	/SA3S0	With Pressure Clamp Terminal for Analog Input [Model: ATSA3S-0]
	/SA3D0	With Dual-Redundant Pressure Clamp Terminal for Analog Input [Model: ATSA3D-0]

		Description
Model	ASI533	Analog Output Module with Built-In Barrier (4 to 20 mA, 8-channel, Isolated) (with ISA Standard G3 option and temperature (-20 to 70 °C) option)
Suffix Codes	-S	Standard type
	-H	With HART Communication
	0	Always 0
	0	Always 0
Option Codes	/SS3S0	With Pressure Clamp Terminal for Analog Output [Model: ATSS3S-0]
	/SS3D0	With Dual-Redundant Pressure Clamp Terminal for Analog Output [Model: ATSS3D-0]

		Description
Model	AST143	TC/mV Input Module with Built-In Barrier (16-channel, Isolated) (with ISA Standard G3 option and temperature (-20 to 70 °C) option)
Suffix Codes	-S	Standard type
	0	Always 0
	0	Always 0
Option Codes	/ST4S0	With Pressure Clamp Terminal for TC/mV [Model: ATST4S-0]
	/ST4D0	With Dual-Redundant Pressure Clamp Terminal for TC/mV [Model: ATST4D-0]

		Description
Model	ASR133	RTD/POT Input Module with Built-In Barrier (8-channel, Isolated) (with ISA Standard G3 option and temperature (-20 to 70 °C) option)
Suffix Codes	-S	Standard type
	0	Always 0
	0	Always 0
Option Codes	/SR3S0	With Pressure Clamp Terminal for RTD/POT [Model: ATSR3S-0]
	/SR3D0	With Dual-Redundant Pressure Clamp Terminal for RTD/POT [Model: ATSR3D-0]

● **Digital I/O Module with Built-In Barrier**

		Description
Model	ASD143	Digital Input Module with Built-In Barrier (16-channel, NAMUR Compatible, Isolated) (with ISA Standard G3 option and temperature (-20 to 70 °C) option)
Suffix Codes	-P	With pulse count
	0	Always 0
	0	Always 0
Option Codes	/SB4S0	With Pressure Clamp Terminal Block for Digital Input [Model: ATSB4S-0]
	/SB4D0	With Dual-Redundant Pressure Clamp Terminal Block for Digital Input [Model: ATSB4D-0]

		Description
Model	ASD533	Digital Output Module with Built-In Barrier (8-channel, Isolated) (with ISA Standard G3 option and temperature (-20 to 70 °C) option)
Suffix Codes	-S	Standard type
	0	Always 0
	0	Always 0
Option Codes	/SD3S0	With Pressure Clamp Terminal Block for Digital Output [Model: ATSD3S-0]
	/SD3D0	With Dual-Redundant Pressure Clamp Terminal Block for Digital Output [Model: ATSD3D-0]

■ **ORDERING INFORMATION**

Specify models and suffix codes.

■ **TRADEMARK**

- CENTUM is a registered trademark of Yokogawa Electric Corporation.
- HART is a registered trademark of the HART Communication Foundation.
- Other company and product names appearing in this document are trademarks or registered trademarks of their respective holders.