



## Main

Range of product	Altivar Machine ATV340
Product or component type	Variable speed drive
Product specific application	Machine
Variant	Standard version
Mounting mode	Cabinet mount
Communication port protocol	Modbus serial
Option card	Communication module, Profibus DP V1 Communication module, Profinet Communication module, DeviceNet Communication module, CANopen Communication module, EtherCAT
Network number of phases	3 phases
Supply frequency	50...60 Hz +/- 5 %
[Us] rated supply voltage	380...480 V - 15...10 %
Nominal output current	32.0 A
Motor power kW	18.5 kW for normal duty 15 kW for heavy duty
Motor power hp	25 hp for normal duty 20 hp for heavy duty
EMC filter	Class C3 EMC filter integrated
IP degree of protection	IP20

## Complementary

Discrete input number	5
Discrete input type	PTI programmable as pulse input: 0...30 kHz, 24 V DC (30 V) DI1...DI5 safe torque off, 24 V DC (30 V), impedance: 3.5 kOhm programmable
Number of preset speeds	16 preset speeds
Discrete output number	2.0

Discrete output type	Programmable output DQ1, DQ2 30 V DC 100 mA
Analogue input number	2
Analogue input type	A11 software-configurable current: 0...20 mA, impedance: 250 Ohm, resolution 12 bits A11 software-configurable temperature probe or water level sensor A11 software-configurable voltage: 0...10 V DC, impedance: 31.5 kOhm, resolution 12 bits A12 software-configurable voltage: - 10...10 V DC, impedance: 31.5 kOhm, resolution 12 bits
Analogue output number	2
Analogue output type	Software-configurable voltage AQ1: 0...10 V DC impedance 470 Ohm, resolution 10 bits Software-configurable current AQ1: 0...20 mA impedance 500 Ohm, resolution 10 bits
Relay output number	2
Output voltage	<= power supply voltage
Relay output type	Relay outputs R1A Relay outputs R1C electrical durability 100000 cycles Relay outputs R2A Relay outputs R2C electrical durability 100000 cycles
Maximum switching current	Relay output R1C on resistive load, cos phi = 1: 3 A at 250 V AC Relay output R1C on resistive load, cos phi = 1: 3 A at 30 V DC Relay output R1C on inductive load, cos phi = 0.4 and L/R = 7 ms: 2 A at 250 V AC Relay output R1C on inductive load, cos phi = 0.4 and L/R = 7 ms: 2 A at 30 V DC Relay output R2C on resistive load, cos phi = 1: 5 A at 250 V AC Relay output R2C on resistive load, cos phi = 1: 5 A at 30 V DC Relay output R2C on inductive load, cos phi = 0.4 and L/R = 7 ms: 2 A at 250 V AC Relay output R2C on inductive load, cos phi = 0.4 and L/R = 7 ms: 2 A at 30 V DC
Minimum switching current	Relay output R1B: 5 mA at 24 V DC Relay output R2C: 5 mA at 24 V DC
Physical interface	2-wire RS 485
Connector type	1 RJ45
Method of access	Slave Modbus RTU
Transmission rate	4.8 kbit/s 9.6 kbit/s 19.2 kbit/s 38.4 kbit/s
Transmission frame	RTU
Number of addresses	1...247
Data format	8 bits, configurable odd, even or no parity
Type of polarization	No impedance
4 quadrant operation possible	True
Asynchronous motor control profile	Variable torque standard Optimized torque mode Constant torque standard
Synchronous motor control profile	Reluctance motor Permanent magnet motor
Pollution degree	2 conforming to EN/IEC 61800-5-1
Maximum output frequency	0.599 kHz
Acceleration and deceleration ramps	Linear adjustable separately from 0.01...9999 s S, U or customized
Motor slip compensation	Automatic whatever the load Adjustable Not available in permanent magnet motor law Can be suppressed
Switching frequency	2...16 kHz adjustable 7...16 kHz with derating factor
Nominal switching frequency	4 kHz
Braking to standstill	By DC injection
Brake chopper integrated	True
Line current	37.4 A at 380 V (normal duty) 30.2 A at 480 V (normal duty) 44.9 A at 380 V (heavy duty) 35.7 A at 480 V (heavy duty)
Line current	44.9 A at 380 V without line choke (heavy duty) 35.7 A at 480 V without line choke (heavy duty) 42.4 A at 380 V with external line choke (normal duty) 34.1 A at 480 V with external line choke (normal duty)

	45.5 A at 380 V with external line choke (heavy duty) 36.0 A at 480 V with external line choke (heavy duty)
Maximum input current	44.9 A
Maximum output voltage	480 V
Apparent power	28.3 kVA at 480 V (normal duty) 29.7 kVA at 480 V (heavy duty)
Maximum transient current	42.9 A during 60 s (normal duty) 48 A during 60 s (heavy duty) 52.7 A during 2 s (normal duty) 58 A during 2 s (heavy duty)
Electrical connection	Screw terminal, clamping capacity: 0.2...2.5 mm <sup>2</sup> for control Screw terminal, clamping capacity: 6...25 mm <sup>2</sup> for line side Screw terminal, clamping capacity: 6...25 mm <sup>2</sup> for DC bus Screw terminal, clamping capacity: 4...25 mm <sup>2</sup> for motor
Prospective line I <sub>sc</sub>	22 kA
Base load current at high overload	32.0 A
Base load current at low overload	39.0 A
Power dissipation in W	Natural convection: 18 W at 380 V, switching frequency 4 kHz (heavy duty) Forced convection: 346 W at 380 V, switching frequency 4 kHz (heavy duty) Natural convection: 21 W at 380 V, switching frequency 4 kHz (normal duty) Forced convection: 411 W at 380 V, switching frequency 4 kHz (normal duty)
Electrical connection	Control: screw terminal 0.2...2.5 mm <sup>2</sup> /AWG 24...AWG 12 Line side: screw terminal 6...25 mm <sup>2</sup> /AWG 8...AWG 3 DC bus: screw terminal 6...25 mm <sup>2</sup> /AWG 8...AWG 3 Motor: screw terminal 4...25 mm <sup>2</sup> /AWG 10...AWG 3
With safety function Safely Limited Speed (SLS)	True
With safety function Safe brake management (SBC/SBT)	True
With safety function Safe Operating Stop (SOS)	False
With safety function Safe Position (SP)	False
With safety function Safe programmable logic	False
With safety function Safe Speed Monitor (SSM)	False
With safety function Safe Stop 1 (SS1)	True
With sft fct Safe Stop 2 (SS2)	False
With safety function Safe torque off (STO)	True
With safety function Safely Limited Position (SLP)	False
With safety function Safe Direction (SDI)	False
Protection type	Thermal protection: motor Safe torque off: motor Motor phase loss: motor Thermal protection: drive Safe torque off: drive Overheating: drive Overcurrent: drive Output overcurrent between motor phase and earth: drive Output overcurrent between motor phases: drive Short-circuit between motor phase and earth: drive Short-circuit between motor phases: drive Motor phase loss: drive DC Bus overvoltage: drive Line supply overvoltage: drive Line supply undervoltage: drive Input supply loss: drive Exceeding limit speed: drive Break on the control circuit: drive
Width	180.0 mm
Height	385.0 mm
Depth	249.0 mm

Net weight	9.5 kg
Continuous output current	39 A at 4 kHz for normal duty 32 A at 4 kHz for heavy duty

## Environment

Operating altitude	<= 3000 m with current derating above 1000m
Operating position	Vertical +/- 10 degree
Product certifications	UL CSA TÜV EAC CTick
Marking	CE
Standards	EN/IEC 61800-3 EN/IEC 61800-5-1 IEC 60721-3 IEC 61508 IEC 13849-1 UL 618000-5-1 UL 508C
Assembly style	With heat sink
Electromagnetic compatibility	Electrostatic discharge immunity test level 3 conforming to IEC 61000-4-2 Radiated radio-frequency electromagnetic field immunity test level 3 conforming to IEC 61000-4-3 Electrical fast transient/burst immunity test level 4 conforming to IEC 61000-4-4 1.2/50 µs - 8/20 µs surge immunity test level 3 conforming to IEC 61000-4-5 Conducted radio-frequency immunity test level 3 conforming to IEC 61000-4-6
Environmental class (during operation)	Class 3C3 according to IEC 60721-3-3 Class 3S3 according to IEC 60721-3-3
Maximum acceleration under shock impact (during operation)	70 m/s <sup>2</sup> at 22 ms
Maximum acceleration under vibrational stress (during operation)	5 m/s <sup>2</sup> at 9...200 Hz
Maximum deflection under vibratory load (during operation)	1.5 mm at 2...9 Hz
Permitted relative humidity (during operation)	Class 3K5 according to EN 60721-3
Volume of cooling air	128.0 m <sup>3</sup> /h
Type of cooling	Forced convection
Overvoltage category	Class III
Regulation loop	Adjustable PID regulator
Noise level	55.6 dB
Pollution degree	2
Ambient air transport temperature	-40...70 °C
Ambient air temperature for operation	-15...50 °C without derating (vertical position) 50...60 °C with derating factor (vertical position)
Ambient air temperature for storage	-40...70 °C
Isolation	Between power and control terminals

## Packing Units

Unit Type of Package 1	PCE
Number of Units in Package 1	1
Package 1 Weight	11.14 kg
Package 1 Height	34 cm
Package 1 width	30.5 cm
Package 1 Length	56 cm
Unit Type of Package 2	BB1
Number of Units in Package 2	1
Package 2 Weight	11.35 kg

Package 2 Height	33.7 cm
Package 2 width	29.8 cm
Package 2 Length	54.8 cm
Unit Type of Package 3	P06
Number of Units in Package 3	2
Package 3 Weight	35.28 kg
Package 3 Height	80 cm
Package 3 width	80 cm
Package 3 Length	60 cm

### Offer Sustainability

Sustainable offer status	Green Premium product
REACH Regulation	<a href="#">REACH Declaration</a>
EU RoHS Directive	Pro-active compliance (Product out of EU RoHS legal scope) <a href="#">EU RoHS Declaration</a>
Mercury free	Yes
RoHS exemption information	<a href="#">Yes</a>
China RoHS Regulation	<a href="#">China RoHS declaration</a>
Environmental Disclosure	<a href="#">Product Environmental Profile</a>
Circularity Profile	<a href="#">End of Life Information</a>
WEEE	The product must be disposed on European Union markets following specific waste collection and never end up in rubbish bins
California proposition 65	WARNING: This product can expose you to chemicals including: Lead and lead compounds, which is known to the State of California to cause cancer and birth defects or other reproductive harm. For more information go to <a href="http://www.P65Warnings.ca.gov">www.P65Warnings.ca.gov</a>
Upgradeability	<a href="#">Upgraded components available</a> 

Dimensions

Views: Front - Left - Rear

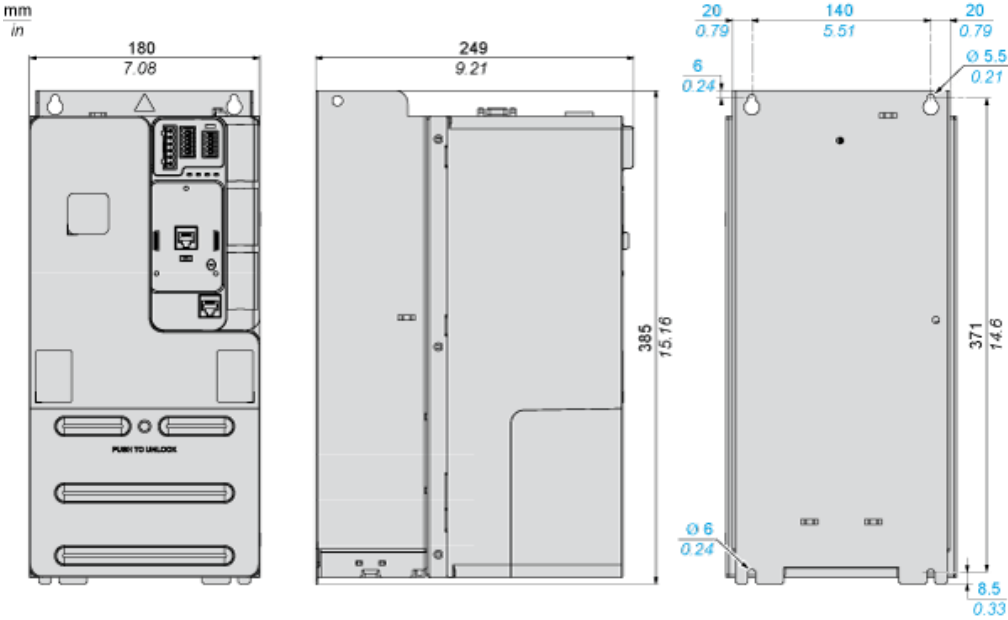

Clearance

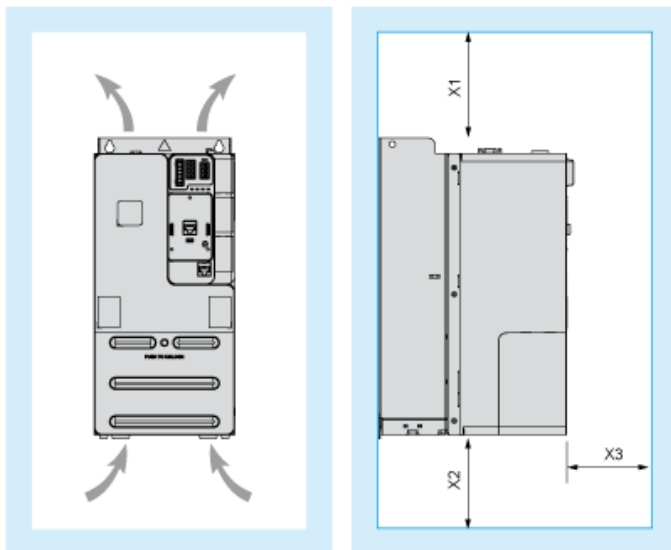

Dimensions in mm

X1	X2	X3
≥ 100	≥ 100	≥ 60

Dimensions in in.

X1	X2	X3
≥ 3.94	≥ 3.94	≥ 2.36

---

Mounting Types

---

Mounting Type A: Side by Side IP20

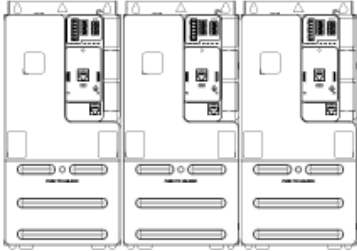

Possible, at ambient temperature  $\leq 50\text{ }^{\circ}\text{C}$  (122  $^{\circ}\text{F}$ )

Mounting Type B: Individual IP20

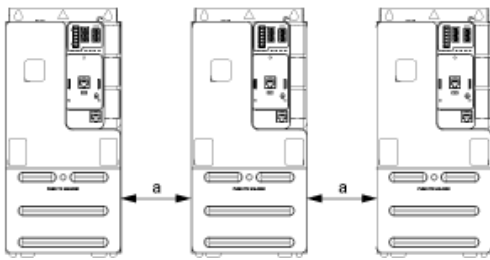

$a \geq 50\text{ mm}$  (1.97 in.) from 50...60 $^{\circ}\text{C}$ , no restriction below 50 $^{\circ}\text{C}$

Connections and Schema

Three-phase Power Supply with Upstream Breaking via Line Contactor Without Safety Function STO

Connection diagrams conforming to standards ISO13849 category 1 and IEC/EN 61508 capacity SIL1, stopping category 0 in accordance with standard IEC/EN 60204-1.

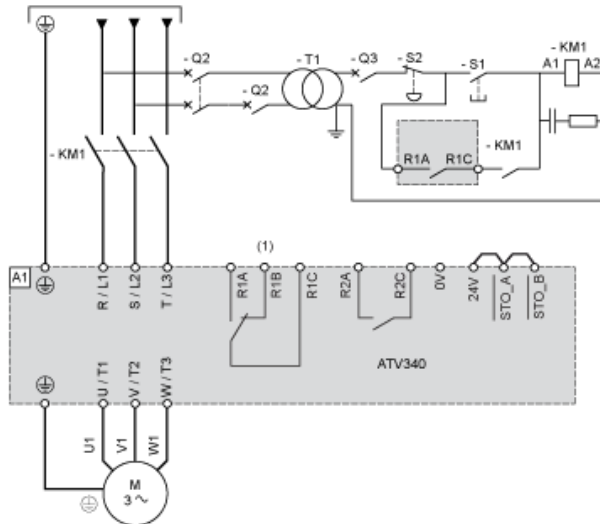

- (1) Use relay output R1 set to operating state Fault to switch Off the product once an error is detected.  
A1 : Drive  
KM1 : Line Contactor  
Q2, Q3 : Circuit breakers  
S1 : Pushbutton  
S2 : Emergency stop  
T1 : Transformer for control part

Three-phase Power Supply With Downstream Breaking via Switch Disconnecter

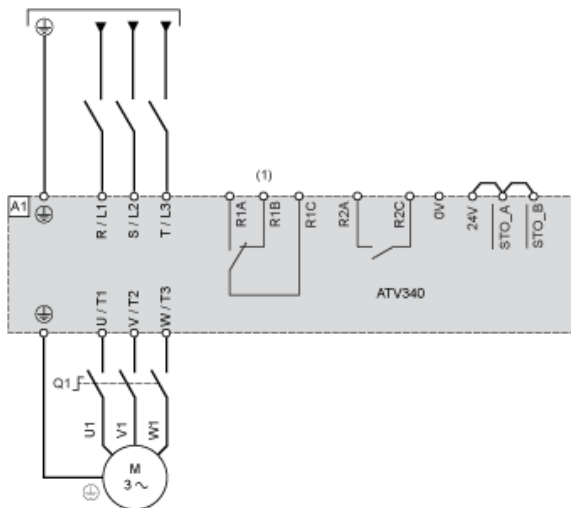

- (1) Use relay output R1 set to operating state Fault to switch Off the product once an error is detected.  
A1 : Drive  
Q1 : Switch disconnecter

# Sensor Connection

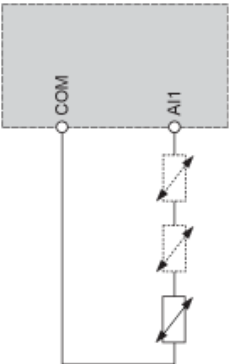

It is possible to connect either 1 or 3 sensors on terminals AI1.



## Digital Inputs Wiring

### Digital Inputs: Internal Supply

Using DISUP Signal

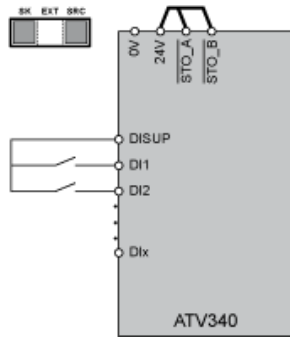

In SRC position DISUP outputs 24 V. In SK position DISUP is connected to 0 V.

### Digital Inputs: External Supply

Positive Logic, Source, European Style

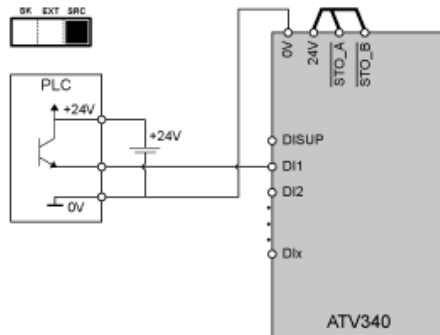

Negative Logic, Sink, Asian Style

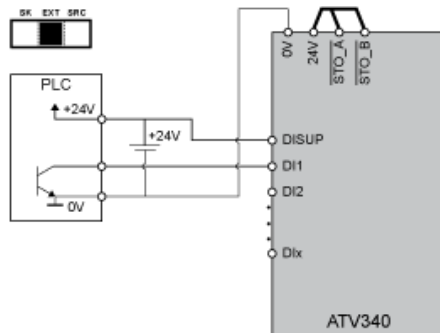

## Digital Inputs: Internal supply

Negative Logic, Sink, Asian Style

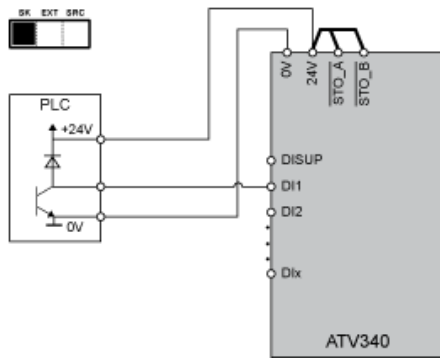

## Digital Outputs Wiring

### Digital Outputs: Internal Supply

Positive Logic, Source, European Style, DQCOM to +24V

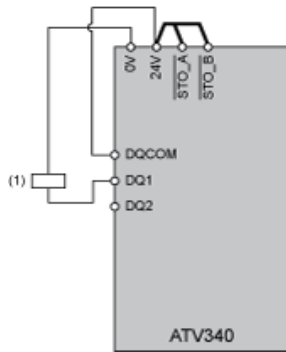

(1) Relay or valve

Negative Logic, Sink, Asian Style, DQCOM to 0V

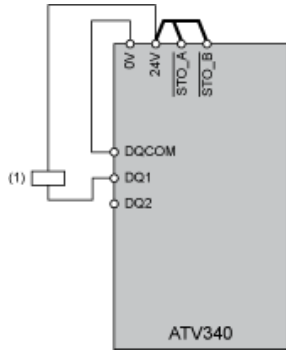

(1) Relay or valve

### Digital Outputs: External Supply

Positive Logic, Source, European Style, DQCOM to +24V

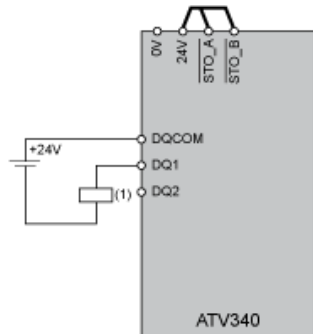

(1) Relay or valve

Negative Logic, Sink, Asian Style, DQCOM to 0V

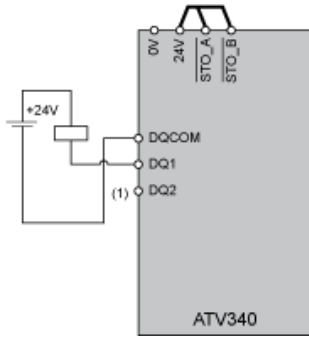

(1) Relay or valve

Open Loop Applications

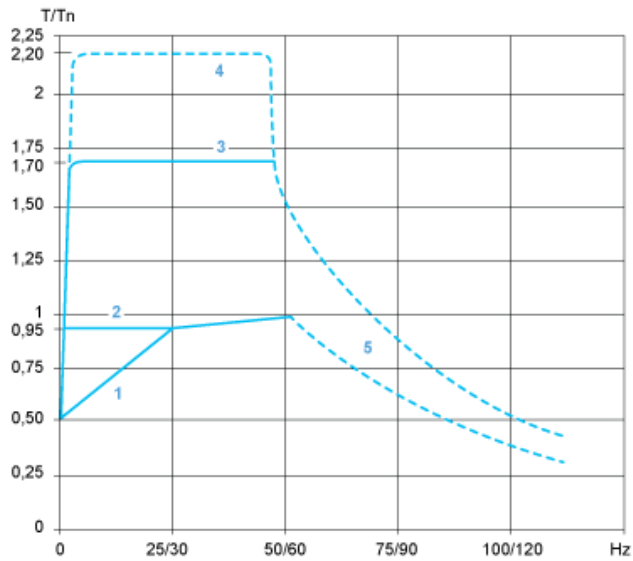

- 1 : Self-cooled motor: continuous useful torque
- 2 : Force-cooled motor: continuous useful torque
- 3 : Overtorque for 60 s maximum
- 4 : Transient overtorque for 2 s maximum
- 5 : Torque in overspeed at constant power

Closed Loop Applications

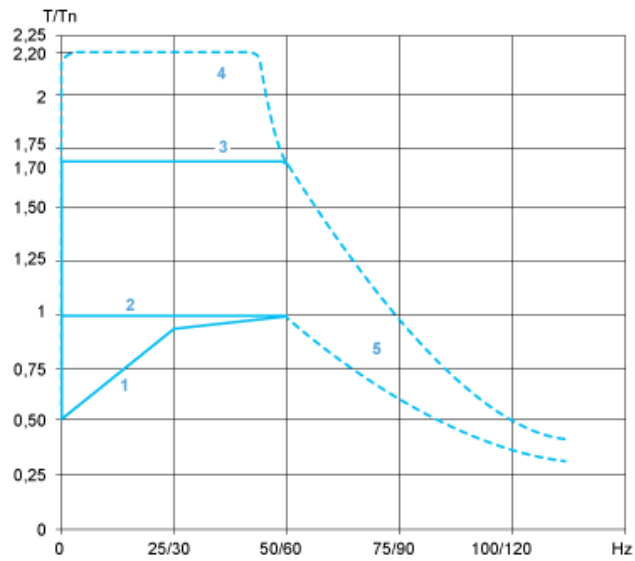

- 1 : Self-cooled motor: continuous useful torque
- 2 : Force-cooled motor: continuous useful torque
- 3 : Overtorque for 60 s maximum
- 4 : Transient overtorque for 2 s maximum
- 5 : Torque in overspeed at constant power