

General Specifications

Analog I/O Modules (for FIO)



GS 33K50F60-50E

[Release 5]

■ GENERAL

*This document describes about hardware specifications of Analog I/O Modules (for FIO) to be installed in the ESB bus node units (ANB10S and ANB10D), Optical ESB bus node units (ANB11S and ANB11D), ER bus node units (ANR10S and ANR10D) (*1), and field control units (for FIO) (AFV30S, AFV30D, AFV40S, AFV40D, AFV10S, AFV10D, AFF50S, and AFF50D).*

These analog I/O modules function as signal converters; by inputting field analog signals into these modules, it converts them to internal data for field control stations (FCS), or the FCS's internal data to analog signals for outputs.

*1: Field control units (AFV30□ and AFV40□) do not support ER bus node unit (ANR10□).

■ STANDARD SPECIFICATIONS

● Current/Voltage Input Modules (Non-Isolated)

These modules provide 16 inputs of mainly 4 to 20 mA DC or 1 to 5 V DC standardized signals from 2-wire/4-wire transmitters.

They can be used in dual-redundant configuration.

Items		Specifications			
Model		AAI141 (*1)	AAV141	AAV142	AAB141(*1) (*4)
Number of input channels		16, non-isolated	16, non-isolated (differential input)	16, non-isolated	16, non-isolated When the voltage input is selected the differential input is applied.
Input signal		4 to 20 mA DC	1 to 5 V DC (allowable common mode voltage ± 1 V or less)	-10 to 10 V DC	Voltage input : 1 to 5 V DC (allowable common mode voltage ± 1 V or less) Current input : 4 to 20 mA DC(*5)
Allowable input current/voltage		27 mA	±7.5 V	±13 V	Voltage input : ±7.5 V Current input : 25 mA
Withstanding voltage		—			
Input resistance	Power ON	400 Ω (at 20 mA) to 1000 Ω (at 4 mA) (*2)	1 MΩ or larger	1 MΩ or larger	Voltage input : 1 MΩ or larger Current input : 290 Ω (at 20 mA) to 450 Ω (at 4 mA) (*6)
	Power OFF	500 kΩ or larger	340 kΩ or larger	660 kΩ or larger	Voltage input : 340 kΩ or larger Current input : 500 kΩ or larger
Accuracy		±16 μA	±4 mV	±20 mV	Voltage input : ±4 mV Current input : ±16 μA
Data update period		10 ms			
Step response time		100 ms			
Transmitter power supply		14.8 V or higher (at 20 mA) (*3) 26.4 V or less (at 0 mA) (output current limit: 27 mA)	—		
Setting of 2-wire or 4-wire transmitter		For each channel by setting pin	—		
Drift due to ambient temperature change		±16 μA/10 °C	±4 mV/10 °C	±20 mV/10 °C	±0.1 %/10 °C
Maximum current consumption		310 mA (5 V DC), 450 mA (24 V DC)	350 mA (5 V DC)	350 mA (5 V DC)	480 mA (5 V DC), 120 mA (24 V DC)
Weight		0.2 kg	0.2 kg	0.2 kg	0.3 kg
External connection		Pressure clamp terminal, KS cable, MIL connector cable			KS cable
HART communication (*7)		Available	—	—	Available (at current input)

*1: A Zener barrier is not allowed to be connected with this module. Use an isolation barrier when the module is used in intrinsically safe application.

*2: The module input resistance viewed from the terminals depends on the current strength as calculated as below:

$$250 \Omega + \frac{\text{voltage drop in the input protection circuit}}{\text{current value}} \quad \text{F01E.ai}$$

*3: This voltage is generated between the connecting terminals for 2-wire transmitters for this module. When calculating the minimum operating voltage for transmitters, consider to allow margins for voltage drop in external wiring.

*4: This module can be used only with the following FCSs – AFG30□, AFG40□, AFG8□□, AFF50□, AFV10□, AFV30□, or AFV40□.

*5: Input mode for each channel is selectable by software.

*6: The module input resistance viewed from the terminals depends on the current strength as calculated as below:

$$250 \Omega + \frac{\text{voltage drop in the input protection circuit}}{\text{current value}} \quad \text{F02E.ai}$$

*7: When this module is installed to a ER bus node unit with HART function, the EB401 firmware must be rev. 2 or later.

● **Current/Voltage I/O Modules (Non-Isolated)**

These modules provide 8 inputs and 8 outputs to support up to 8 loops. They can be used in dual-redundant configuration.

Items		Specifications						
Model		AAI841 (*1)		AAB841 (*5)		AAB842 (*5) (*6)		
Number of I/O channels		8-channel input/8-channel output, non-isolated		8-channel input/8-channel output, non-isolated (differential input)		8-channel input/8-channel output, non-isolated When the voltage input is selected the differential input is applied.		
I/O signal		Input: 4 to 20 mA	Output: 4 to 20 mA	Input: 1 to 5 V (allowable common mode voltage ±1 V or less)	Output: 4 to 20 mA	Input (*7) Voltage input: 1 to 5 V DC (allowable common mode voltage ±1 V or less) Current input: 4 to 20 mA DC	Output: 4 to 20 mA	
Allowable input current/voltage		25 mA	—	±7.5 V	—	Voltage input : ±7.5 V Current input : 25 mA	—	
Withstanding voltage		—						
Input resistance		Power ON	400 Ω (at 20 mA) to 1000 Ω (at 4 mA) (*2)	—	1 MΩ or larger	—	Voltage input: 1 MΩ or larger Current input: 290 Ω (at 20 mA) to 450 Ω (at 4 mA) (*2)	—
		Power OFF	500 kΩ or larger	—	340 kΩ or larger	—	Voltage input: 340 kΩ or larger Current input: 500 kΩ or larger	—
Allowable load resistance		—	0 to 750 Ω (*3)	—	0 to 750 Ω	—	0 to 750 Ω (*4)	
Circuit-open detection		—	Less than 0.65 mA	—	Less than 0.65 mA	—	Less than 0.65 mA	
Accuracy		Input: ±16 μA	output: ±48 μA	Input: ±4 mV	output: ±48 μA	Voltage input : ±4 mV Current input : ±16 μA	±48 μA	
Data update period		10 ms						
Input step response time		100 ms						
Output step response time		40 ms						
Transmitter power supply		14.8 V or higher (at 20 mA) 26.4 V or less (at 0 mA) (*4)		—				
Setting of 2-wire or 4-wire transmitter		For each channel by setting pin		—				
Temperature drift		±0.1 %/10 °C						
Maximum current consumption		310 mA (5 V DC), 500 mA (24 V DC)		310 mA (5 V DC), 250 mA (24 V DC)		410 mA (5 V DC), 290 mA (24 V DC)		
Weight		0.3 kg						
External connection		Pressure clamp terminal, KS cable, MIL connector cable				KS cable		
HART communication (*8)		Available		—		Available (at Current input and output)		

*1: A Zener barrier is not allowed to be connected with this module. Use an isolation barrier when the module is used in intrinsically safe application.

*2: The module input resistance viewed from the terminals depends on the current strength as calculated as below:

$$250 \Omega + \frac{\text{voltage drop in the input protection circuit}}{\text{current value}}$$

F03E.ai

*3: When this module is used in the ambient temperature of 60 to 70 °C by being installed in a node unit that conforms to the temperature environment, the allowable load resistance is 200 to 750 Ω.

*4: This voltage is generated between the connecting terminals for 2-wire transmitters for this module. When calculating the minimum operating voltage for transmitters, consider to allow margins for voltage drop in external wiring.

*5: A Zener barrier is not allowed to be connected with this module for current output. Use an isolation barrier when the module is used in intrinsically safe application.

*6: A Zener barrier is not allowed to be connected with this module for current input. Use an isolation barrier when the module is used in intrinsically safe application. And this module can be used only with the following FCSs – AFG30□, AFG40□, AFG8□□, AFF50□, AFV10□, AFV30□, or AFV40□.

*7: Input mode for each channel is selectable by software.

*8: When this module is installed to a ER bus node unit with HART function, the EB401 firmware must be rev. 2 or later.

● **Voltage Output Module (Non-Isolated)**

This module provides 16 outputs of -10 to +10 V DC signal. It can be used in dual-redundant configuration.

Items	Specifications
Model	AAV542
Number of output channels	16, non-isolated
Output signal	-10 to 10 V
Withstanding voltage	—
Allowable load resistance	10 kΩ or larger
Accuracy	Larger of ±0.3 %/FS and ±12 mV
Data update period	10 ms
Output step response time	40 ms
Temperature drift	Larger of ±0.1 %/10 °C and ±10 mV/10 °C
Maximum current consumption	450 mA (5 V DC)
Weight	0.2 kg
External connection	Pressure clamp terminal, KS cable, MIL connector cable

● **Current Input Modules (Isolated)**

This module provides 16 inputs of 4 to 20 mA signal. It can be used in dual-redundant configuration.

Items	Specifications	
Model	AAI143 (*1)	
Number of input channels	16, isolated	
Input signal	4 to 20 mA	
Allowable input current	24 mA	
Withstanding voltage	Between input and system: 1500 V AC, for 1 minute (*4)	
Input resistance	Power ON	270 Ω (20 mA) to 350 Ω (4 mA) (*2)
	Power OFF	500 kΩ or larger
Accuracy	±16 μA	
Data update period	10 ms	
Transmitter power supply	19.0 V or higher (at 20 mA) 25.5 V or less (at 0 mA) (output current limit: 25 mA) (*5)	
Setting of 2-wire or 4-wire transmitter	For each channel by setting pin	
Drift due to ambient temperature change	±16 μA/10 °C	
Maximum current consumption	230 mA (5 V DC), 540 mA (24 V DC)	
Weight	0.3 kg	
External communication	Pressure clamp terminal, MIL connector cable, dedicated cable (KS1)	
HART communication (*3)	Available	

*1: A Zener barrier is not allowed to be connected with this module. Use an isolation barrier when the module is used in intrinsically safe application.

*2: The module input resistance viewed from the terminals depends on the current strength as calculated as below:

$$250 \Omega + \frac{\text{voltage drop in the input protection circuit}}{\text{current value}} \quad \text{F04E.ai}$$

*3: When this module is installed to a ER bus node unit with HART function, the EB401 firmware must be rev. 2 or later.

*4: When the dedicated cable is used, the withstanding voltage is 500 V AC (between the input signal and the system). When the ML connector cable is used, the withstanding voltage depends on the electrical specifications of the cable.

*5: This voltage is generated between the connecting terminals for 2-wire transmitters for this module. When calculating the minimum operating voltage for transmitters, consider to allow margins for voltage drop in external wiring.

● **Current Output Module (Isolated)**

This module provides 16 outputs of 4 – 20 mA signal. It can be used in dual-redundant configuration. (*1)

Items	Specifications	
	Model	AAI543-□5□/-□E□
Number of output channels	16, isolated, standard switch-over response in redundant configuration (*3)	16, isolated, fast switch-over response in redundant configuration (*3)
Output signal	4 to 20 mA	
Withstanding voltage	Between output and system: 1500 V AC, for 1 minute (*4)	
Allowable load resistance	0 to 750 Ω	
Circuit-open detection	Less than 0.65 mA	
Accuracy	±48 μA	
Data update period	10 ms	
Drift due to ambient temperature change	±16 μA/10 °C	
Maximum current consumption	230 mA (5 V DC), 540 mA (24 V DC)	
Weight	0.4 kg	
External communication	Pressure clamp terminal, MIL connector cable, dedicated cable (KS1)	
HART communication (*5)	Available	

- *1: A dual-redundant configuration is enabled by using two identical modules with the same suffix codes.
- *2: When AAI543-□6□/-□F□ is installed in a node unit that conforms to the temperature environment, use it in the ambient temperature within 0 to 60 °C range.
- *3: When a switch over from control to stand-by module takes place in the dual-redundant configuration, the maximum period of time when the field output falls below 4 mA is 100 ms for AAI543-□5□/-□E□ (standard switch-over response) and 2 ms for AAI543-□6□/-□F□ (fast switch-over response). In case of connecting fast response type field devices, use AAI543-□6□/-□F□ (fast switch-over response) in the dual-redundant configuration.
- *4: When the dedicated cable is used, the withstanding voltage is 500 V AC (between the input signal and the system). When the ML connector cable is used, the withstanding voltage depends on the electrical specifications of the cable.
- *5: When this module is installed in a ER bus node unit with HART function, the EB401 firmware must be rev. 2 or later.

● **Voltage Input Module (Isolated)**

This module is for 16 inputs of 1 to 5 V or -10 to 10 V signal. It can be used in dual-redundant configuration.

Items	Specifications		
	Model	AAV144	
Number of input channels	16, isolated		
Input signal	1 to 5 V	-10 to 10 V	
Switching input signals	Input signals can be set together for CH1 to CH16		
Allowable input voltage	±30 V		
Withstanding isolated voltage	Between input and system: 1500 V AC withstanding voltage, for 1 minute (*1)		
Input resistance	Power ON	1 MΩ	
	Power OFF	200 kΩ	
Accuracy	±4 mV	±20 mV	
Data update period	10 ms		
Drift due to ambient temperature change	±4 mV/10 °C	±20 mV/10 °C	
Maximum current consumption	500 mA (5 V DC)		
Weight	0.2 kg		
External communication	Pressure clamp terminal, MIL connector cable, dedicated cable (KS1)		

- *1: When the dedicated cable is used, the withstanding voltage is 500 V AC (between the input signal and the system). When the ML connector cable is used, the withstanding voltage depends on the electrical specifications of the cable.

● Voltage Output Modules (Isolated)

This module is for 16 outputs of -10 to 10V signal. It can be used in dual-redundant configuration.

Items	Specifications
Model	AAV544
Number of output channels	16, isolated
Output signal	-10 to 10 V
Withstanding voltage	Between output and system: 1500 V AC withstanding voltage, for 1 minute (*1)
Allowable load resistance	5 k Ω or larger
Accuracy	The larger of ± 12 mV or ± 0.3 % FS
Data update period	10 ms
Drift due to ambient temperature change	The larger of ± 0.1 %/10 °C or ± 10 mV/10 °C
Maximum current consumption	860 mA (5 V DC)
Weight	0.2 kg
External communication	Pressure clamp terminal, MIL connector cable, dedicated cable (KS1)

*1: When the dedicated cable is used, the withstanding voltage is 500 V AC (between the input signal and the system). When the ML connector cable is used, the withstanding voltage depends on the electrical specifications of the cable.

● **TC/RTD Input Modules (Isolated)**

These modules receive signals from mV, thermocouple (TC), and RTD. They can be used in dual-redundant configuration.

Items	Specifications	
	AAT141	AAR181
Number of input channels	16, isolated (*7)	12, isolated
Input signal	TC: JIS C1602:1995, IEC584:1995 Type J, K, E, B(*1), R, S, T, N mV: -100 to 150 mV, -20 to 80 mV	RTD: JIS C1604:1997, IEC751:1995 Pt100 (3-wire type)(*6)
Switching input signals	TC/mV can be set individually for CH1 to CH16.	CH1 to CH12 are RTD inputs.
Allowable input voltage	±5 V	±5 V
Withstanding voltage	Between input and system: 1500 V AC, for 1 minute	
Input resistance	Power ON	2 MΩ or larger
	Power OFF	2 MΩ or larger
Accuracy	TC: ±30 μV mV: ±80 μV for span (-100 to 150 mV) ±30 μV for span (-20 to 80 mV)	RTD: ±120 mΩ
Allowable total resistance of signal source plus wiring	1000 Ω or less	40 Ω or less (wiring resistance per wire) (*2)
Effect of allowable signal source resistance (1000 Ω)	±20 μV(*3)	—
Reference junction compensation accuracy	Within ±1 °C (*4) (*5)	—
Measurement current	—	RTD: 1 mA
Temperature drift	±80 μV/10 °C (-100 to 150 mV input) ±30 μV/10 °C (TC/-20 to 80 mV input)	±120 mΩ/10 °C (RTD input)
Data update period	1 s	
Burn-out	All channels can be set together. Setting: Not available/available (UP/DOWN) Detection time: 60 s	
Maximum current consumption	450 mA (5 V DC)	450 mA (5 V DC)
Weight	0.2 kg	
External connection	Pressure clamp terminal	

- *1: Type B does not carry out temperature compensation and temperature under 44 °C is not measurable.
- *2: Wiring resistance for the signal cables of IN□A and IN□C must be identical.
- *3: In dual-redundant configuration, it is ±40 μV.
- *4: This figure varies depending on the installation conditions.
When the measured temperature is below 0 °C, multiply the following coefficient (K) with the above value.

$$K = \frac{\text{Thermoelectromotive force per degree at } 0\text{ }^{\circ}\text{C}}{\text{Thermoelectromotive force per degree at measured temperature}}$$

F05E.ai

- *5: The reference junction compensation accuracy varies depending on the ambient temperature of the pressure clamp terminal.

By the Node Unit Only

Temperature Environment	Reference Junction Compensation Accuracy
-20 to 15 °C	±2 °C
15 to 45 °C	±1 °C
45 to 70 °C	±2 °C

Installed in the Standard Cabinet

Temperature Environment	Reference Junction Compensation Accuracy
0 to 50 °C	±2 °C

- *6: AAR181 also supports JPt 100.
- *7: Use a non-ground type thermocouple (TC) because AAT141 is an isolated type module. When the ground type TC is used with the module's multiple channels, it causes a temperature error due to the multi-point ground.

● **Current Input Module and Current I/O Module (Isolated Channels)**

The current input module receives signal of 4 to 20 mA, and the current I/O module sends and receives signals of 4 to 20 mA. These modules are isolated between the field and the system as well as in between each channel. They can be used in dual-redundant configuration.

Items		Specifications	
Model		AAI135 (*1)	AAI835 (*1)
Number of I/O channels		8-channel input, isolated channels	4-channel input/4-channel output, isolated channels
I/O signal		4 to 20 mA	Input: 4 to 20 mA Output: 4 to 20 mA
Allowable input current		25 mA	25 mA —
Withstanding voltage		Between input and system: 500 V AC, for 1 minute Between input channels: 500 V AC, for 1 minute (*2)	Between input/output and system: 500 V AC, for 1 minute Between input/output channels: 500 V AC, for 1 minute (*2)
Input resistance	Power ON	290 Ω (at 20 mA) to 450 Ω (at 4 mA) (*3)	
	Power OFF	500 kΩ or larger	
Allowable load resistance		—	0 to 750 Ω (*4)
Circuit-open detection		—	Less than 0.65 mA
Accuracy		±16 μA	Input: ±16 μA Output: ±48 μA
Data update period		10 ms	
Transmitter power supply		15.0 V or higher (at 20 mA) 29.3 V or less (at 0 mA) (*5)	15.0 V or higher (at 20 mA) 29.3 V or less (at 0 mA) (*5) —
Temperature drift		±16 μA/10 °C	
Maximum current consumption		360 mA (5 V DC), 450 mA (24 V DC)	360 mA (5 V DC), 450 mA (24 V DC)
Weight		0.3 kg	
External connection		Pressure clamp terminal, MIL connector cable, dedicated cable (KS1)	
HART communication (*6)		Available	Available

*1: A Zener barrier is not allowed to be connected with this module. Use an isolation barrier when the module is used in intrinsically safe applications.

*2: When the ML connector cable is used, the withstanding voltage depends on the electrical specifications of the cable.

*3: The module input resistance viewed from the terminals depends on the current strength as calculated as below:

$$250 \Omega + \frac{\text{voltage drop in the input protection circuit}}{\text{current value}}$$

F06E.ai

*4: When this module is used in the ambient temperature of 60 to 70 °C by being installed in a ER bus node unit that conforms to the temperature environment, the allowable load resistance is 200 to 750 Ω.

*5: This voltage is generated between the connecting terminals for 2-wire transmitters for this module. When calculating the minimum operating voltage for transmitters, consider to allow margins for voltage drop in external wiring.

*6: When this module is installed to a ER bus node unit with HART function, the EB401 firmware must be rev. 2 or later.

● **TC/RTD Input Modules (Isolated Channels)**

These modules receive signals from mV, thermocouple (TC), RTD, and potentiometer (POT), and they are isolated between the field and the system as well as in between each channel. They can be used in dual-redundant configuration.

Items		Specifications	
Model		AAT145	AAR145
Number of input channels		16, isolated channels	16, isolated channels
Input signal		TC: JIS C1602:1995 (*1), IEC584:1995 Type J, K, E, B (*2), R, S, T, N mV: -100 to 150 mV, -20 to 80 mV	RTD: JIS C1604:1997 (*3), IEC751:1995 Pt100 (3-wire type) POT: Total resistance 100 Ω to 10 kΩ Span resistance: 50 % or larger of total resistance
Switching input signals		TC/mV can be set individually for CH1 to CH16.	RTD/POT can be selected individually for CH1 to CH16.
Allowable input voltage		±5 V	±5 V
Withstanding voltage		Between input and system: 500 V AC (for single card: 1500 V AC), For 1 minute Between input channels: 200 V AC, For 1 minute	
Input resistance	Power ON	1 MΩ or larger	
	Power OFF	1 MΩ or larger	
Accuracy		±40 μV	RTD: ±150 mΩ POT: ±0.2 %/FS
Allowable total resistance of signal source plus wiring		1000 Ω or less	150 Ω or less (wiring resistance per wire) (*4)
Effect of allowable signal source resistance (1000 Ω)		±20 μV	—
Reference junction compensation accuracy		±1 °C (*5) (6)	—
Measurement current		—	RTD: 1 mA
Data update period		1 s	
Burn-out		All channels can be set together. Setting: not available/available (UP/DOWN) Detection time: 60 s	
Temperature drift		±80 μV/10 °C	RTD: ±0.3 Ω/10 °C POT: ±0.4 %/10 °C
Maximum current consumption		350 mA (5 V DC)	350 mA (5 V DC)
Weight		0.3 kg	
External connection		Dedicated cable (KS1)	Dedicated cable (KS8/AKB335)

- *1: AAT145 also complies with JIS C1602:1981.
- *2: Type B does not carry out temperature compensation and temperature under 44 °C is not measurable.
- *3: AAR145 also complies with JIS C1604:1989 (Pt100, JPt100).
- *4: Wiring resistance for the signal cables of IN□A and IN□C must be identical.
- *5: This figure varies depending on the installation conditions.
When the measured temperature is below 0 °C, multiply the following coefficient (K) with the above value.

$$K = \frac{\text{Thermoelectromotive force per degree at } 0\text{ }^{\circ}\text{C}}{\text{Thermoelectromotive force per degree at measured temperature}}$$

F07E.ai

- *5: The reference junction compensation accuracy varies depending on the ambient temperature of the terminal board (AET4D).

By the Terminal Board Only

Temperature Environment	Reference Junction Compensation Accuracy
-20 to 0 °C	±1.5 °C
0 to 30 °C	±1.0 °C
30 to 70 °C	±1.5 °C

Installing in the Standard Cabinet

Temperature Environment	Reference Junction Compensation Accuracy
0 to 30 °C	±1.0 °C
30 to 50 °C	±1.5 °C

● Pulse Input Module (Isolated Channels)

This module receives contact ON/OFF, voltage pulse, and current pulse signals. It is isolated between the field and the system as well as in between each channel, and can be used in dual-redundant configuration.

Items	Specifications
Model	AAP135
Number of input channels	8, isolated channels
Input signal (*3)	2-wire type: Contact ON/OFF, voltage pulse, current pulse (possible to supply transmitter power supply) 3-wire type: Power-supply-type voltage pulse
Input frequency	0 to 10 kHz (*4)
Withstanding voltage	Between input and system: 500 V AC, for 1 minute Between channels: 500 V AC, for 1 minute (*1)
Minimum input pulse width	40 μ s
Input signal level	Contact input Open/close levels of relay contact and transistor contact Open: 100 k Ω or larger, Close: 200 Ω or less Contact capacity When supplying 12 V DC: 15 V DC 15 mA or higher When supplying 24 V DC: 30 V DC 30 mA or higher Voltage/current pulse input (Current input is converted to voltage.) VH (high level): 3 to 24 V DC VL (low level): -1 to 8 V DC VH-VL (swing value): 3 V or higher Signal source resistance: 1 k Ω or less
Shunt resistance	Can be selected from none/200/500/1000 Ω . (Open when power is OFF and for the standby side in a dual-redundant configuration)
Pull-up resistance	68 k Ω (12 V DC or 24 V DC)
Filter	Filter for eliminating chattering can be set. (*2)
Data update period	2 ms
Transmitter power supply	Can select 24 V DC/12 V DC. Limiter value 12 V DC \pm 10 %: 40 mA, 24 V DC \pm 10 %: 30 mA
Maximum current consumption	300 mA (5 V DC), 400 mA (24 V DC)
Weight	0.3 kg
External connection	Pressure clamp terminal, KS cable, MIL connector cable

*1: When the ML connector cable is used, the withstanding voltage depends on the electrical specifications of the cable.

*2: When the pulse input signal is a dry contact (e. g. mechanical relay) up to 10 Hz, chattering can be eliminated.

*3: Connection methods with field devices vary by the input signals. Refer to the Installation Guidance (TI 33K01J10-50E) for details.

*4: The input frequency is 0 to 800 Hz in between terminals B and C to receive non-voltage contact signals.

● Pulse Input Module Compatible with PM1

This module counts pulses by receiving 16-channel pulse train signal from pulse train input signal conditioner cards.

Items	Specifications
Model	AAP149
Number of input channels	16, non-isolated
Input signal	Transistor contact (open collector)
Input frequency	0 to 6 kHz
Withstanding voltage	–
Pulse detection edge	Trailing edge
Data update period	2 ms
Maximum current consumption	400 mA (5 V DC)
Weight	0.3 kg
External connection	Dedicated cable (KS2)

● Pulse Input Module/Analog Output Module Compatible with PAC

This module receives 8-channel pulse train signal and outputs 4 to 20mA signal. It can be used in dual-redundant configuration.

Items	Specifications	
Model	AAP849	
Number of I/O channels	8-channel input /8-channel output, non-isolated	
I/O signal	Input: transistor contact (open collector)	Output: 4 to 20 mA
Input frequency	0 to 12 kHz	–
Pulse detection edge	Trailing edge	–
Allowable load resistance	–	0 to 750 Ω
Circuit-open detection	–	Less than 0.65 mA
Accuracy	–	$\pm 48 \mu\text{A}$
Data update period	1 ms	10 ms
Output step response time	–	40 ms
Temperature drift	–	$\pm 16 \mu\text{A}/10 \text{ }^\circ\text{C}$
Maximum current consumption	310 mA (5 V DC), 250 mA (24 V DC)	–
Weight	0.3 kg	
External connection	Dedicated cable (KS1)	

■ OPERATING ENVIRONMENT

Hardware Requirements

The analog I/O modules run on the following FCS.

AFV30S, AFV30D, AFV40S, AFV40D, AFV10S, AFV10D,
 AFS30S, AFS30D, AFS40S, AFS40D,
 AFG30S, AFG30D, AFG40S, AFG40D,
 AFG81S, AFG81D, AFG82S, AFG82D, AFG83S, AFG83D, AFG84S, AFG84D,
 AFF50S, and AFF50D

Software Requirements

The analog I/O modules run on the control functions of the following FCS.

LFS1700 Control Function for Field Control Station (for AFV30□/AFV40□, Vnet/IP, and FIO):
 for AFV30□/AFV40□
 LFS1500 Control Function for Field Control Station (for AFV10□, Vnet/IP and FIO): for AFV10□
 LFS1300 Control Function for Standard Field Control Station (for V net and FIO): for AFS30□/AFS40□
 LFS1330 Control Function for Enhanced Field Control Station (for V net and FIO):
 for AFG30□/AFG40□ /AFG8□□
 LFS1350 Control Function for Compact Field Control Station (for V net and FIO): for AFF50□

Engineering Requirements

Works on LHS5100/LHMS5100 Standard Builder Function.

■ ANALOG I/O MODULE (WITH HART COMMUNICATION)

The analog I/O module (with HART communication function) connected to a transmitter or a valve positioner receives HART variable (*1) in addition to exchange analog input/output data by 4 – 20 mA signal with field control stations (FCS). There are 8 types of analog I/O modules (with HART communication function).

*1: HART variable can be read by HART Command #3.

There are 8 types of analog I/O modules (with HART communication function).

Model	Model Name	Function
AAI141-H	Analog Input Module (Current Input)	16-channel, 4 to 20 mA, non-isolated
AAB141-H	Analog Input Module (Voltage/current Input)	16-channel, 1 to 5 V/4 to 20 mA, non-isolated
AAI841-H	Analog I/O Module (Current I/O)	8-channel input/8-channel output, 4 to 20 mA, non-isolated
AAB842-H	Analog I/O Module (Voltage/current Input, Current Output)	8-channel input/8-channel output, 1 to 5 V/4 to 20 mA input, 4 to 20 mA output, non-isolated
AAI135-H	Analog Input Module (Current Input)	8-channel, 4 to 20 mA, isolated channels
AAI835-H	Analog I/O Module (Current I/O)	4-channel input/4-channel output, 4 to 20 mA, isolated channels
AAI143-H	Analog Input Module (Current Input)	16-channel, 4 to 20 mA, isolated
AAI543-H	Analog Output Module (Current Output)	16-channel, 4 to 20 mA, isolated

● Communication with HART Devices

The analog I/O modules (with HART communication function) communicate with field devices and store analog data and HART variables in the Input/Output image area in the communication module. An FCS refers to and sets the Input/Output image by accessing the analog I/O modules (with HART communication function). The FCS utilizes the field device data via I/O terminals of the function block in the same way as other analog/digital I/O signals.

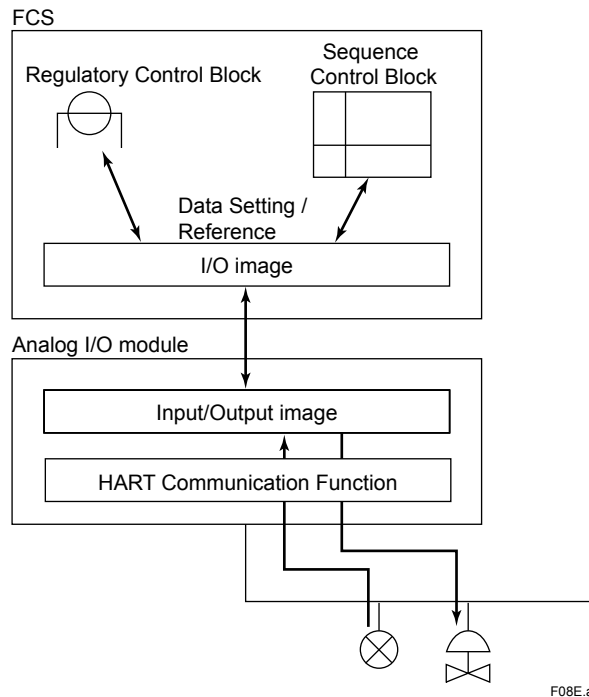

Figure Process Data Flow of HART Communications

● **HART Communication Functional Specifications**

The analog I/O modules (with HART communication function) are equipped with HART modems and enable HART communication (*1) by directly connecting the HART devices to the modules.

No. of HART devices: Max. 16 devices/module

HART variables: Max. 32 points/module

HART variables can be treated as ordinary process input data via %Z terminal connection.

It is just for input.

HART multidrop connection (*2): Max. 5 devices/channel

HART variables data refresh cycle time :

1 second/device (When maximum of 16 devices are connected, it is 17 seconds per ESB bus connection and 19 seconds for ER bus connection.)

Analog data refresh cycle time (*3):

The number of ER bus node unit determines the analog data refresh cycle time in between the ER bus master interface module (EB401) and ER bus node units.

With HART communication, it takes twice as much time than without HART communication.

	No. of ER bus node unit		
	2	4	6
Analog I/O (without HART communication)	50 ms	100 ms	200 ms
Analog I/O (with HART communication)	100 ms	200 ms	400 ms

*1: HART communication refers to HART variable communication, on-demand communication, and hand held terminal (HHT) communication.

*2: It is possible to connect only input devices. This connection does not support analog data value nor burst function.

*3: Field control units (AFV30□ and AFV40□) do not support ER bus node unit (ANR10□).

● **HART Communication Specifications**

Table HART Communication Specifications

Function	Description
Communication mode	Serial half duplex, start-stop synchronization, 1 start/ 8 bit/ odd parity/ 1 stop
Applicable standard	HART Protocol Revision 5.7 (*1)
Transmission speed	1200 ±2 bps
Modulation technique	Binary phase-continuous FSK 1: 1200 Hz ±1 %, 0: 2200 Hz ±1%
Frame length	5 to 267 bytes Contents of max. 267 bytes: Delimiter: 1 Address: 5 Command: 1 Byte count: 1 Data: 255 (includes two bytes of response code) Check byte: 1
Frame detection	3 byte header byte-count carrier (ON/OFF) Preamble: 5 to 20 bytes
Error detection coding	Longitudinal/vertical parity
Response time	Max. 28 characters (256.7 ms)
No response timer	33 characters (305 ms) for primary, 41 characters (380 ms) for secondary
Bus monitor	8 characters (75 ms)
Response window	20 ms

*1: The HART 5, 6, and 7 devices can be connected but applying the HART protocol 5.7 function.

● **HART Communication System Configuration**

The analog I/O modules (with HART communication function) can be configured dual-redundant by placing the two modules in the adjacent slots (odd number and even number slots) on the same node unit.

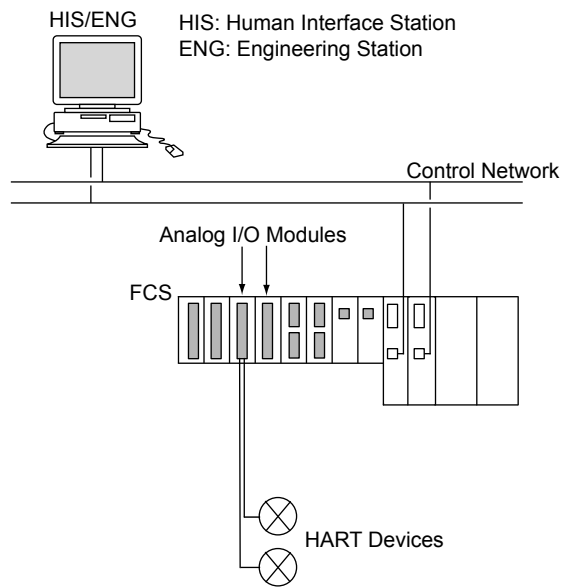

F09E.ai

Figure HART Communication System Configuration (Dual-redundant)

EXTERNAL DIMENSIONS

- AAI141, AAV141, AAV142, AAV144, AAI841, AAB841, AAV542, AAV544, AAI143, AAI543, AAT141, AAR181, AAI135, AAI835, AAP135, AAB141, AAB842

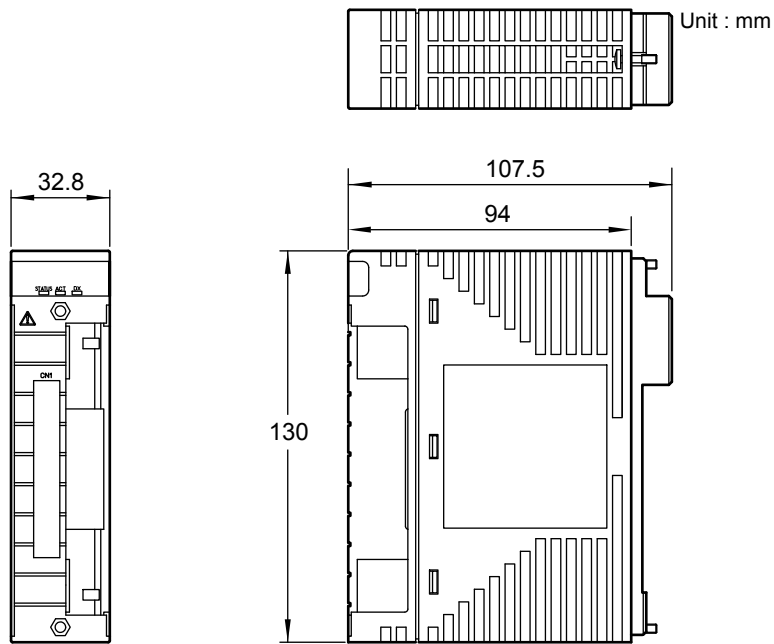

F10E.ai

- AAT145, AAP849

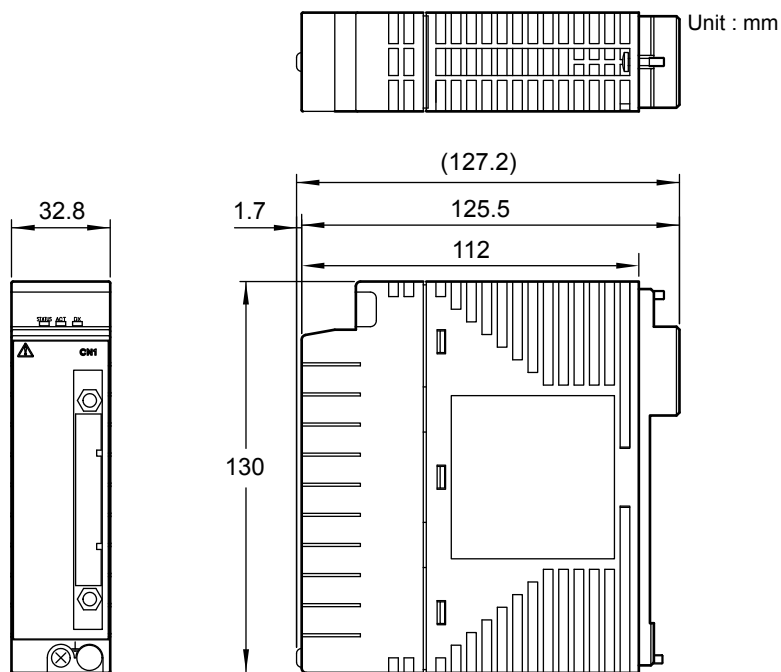

F11E.ai

● AAR145

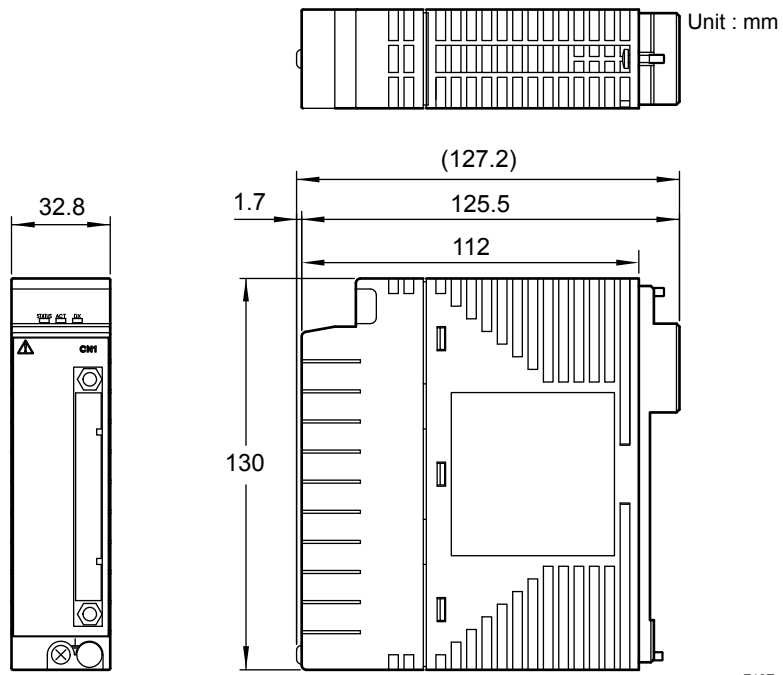

● AAP149

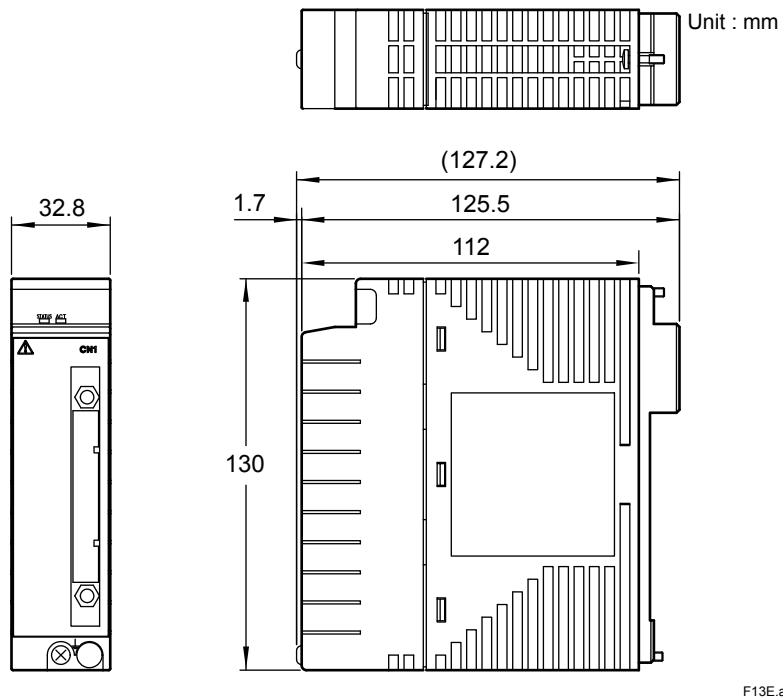

■ MODEL AND SUFFIX CODES

		Description
Model	AAI141	Analog Input Module (4 to 20 mA, 16-channel, Non-Isolated)
Suffix Codes	-S	Standard type
	-H	With digital communication (HART protocol)
	5	With no explosion protection
	E	With explosion protection
	0	Basic type
Option Codes	3	With ISA Standard G3 option and temperature (-20 to 70 °C) option
	/K4A00	With KS Cable Interface Adapter [Model: ATK4A-00]
	/A4S00	With Pressure Clamp Terminal Block for Analog [Model: ATA4S-00]
	/A4S10	With Pressure Clamp Terminal Block for Analog (surge absorber) [Model: ATA4S-10]
	/A4D00	With Dual Pressure Clamp Terminal Block for Analog [Model: ATA4D-00]
	/A4D10	With Dual Pressure Clamp Terminal Block for Analog (surge absorber) [Model: ATA4D-10]
	/CCC01	With Connector Cover for MIL Cable [Model: ACCC01]

		Description
Model	AAV141	Analog Input Module (1 to 5 V, 16-channel, Non-Isolated)
Suffix Codes	-S	Standard type
	5	With no explosion protection
	E	With explosion protection
	0	Basic type
	3	With ISA Standard G3 option and temperature (-20 to 70 °C) option
Option Codes	/K4A00	With KS Cable Interface Adapter [Model: ATK4A-00]
	/A4S00	With Pressure Clamp Terminal Block for Analog [Model: ATA4S-00]
	/A4S10	With Pressure Clamp Terminal Block for Analog (surge absorber) [Model: ATA4S-10]
	/A4D00	With Dual Pressure Clamp Terminal Block for Analog [Model: ATA4D-00]
	/A4D10	With Dual Pressure Clamp Terminal Block for Analog (surge absorber) [Model: ATA4D-10]
	/CCC01	With Connector Cover for MIL Cable [Model: ACCC01]

		Description
Model	AAV142	Analog Input Module (-10 to +10 V, 16-channel, Non-Isolated)
Suffix Codes	-S	Standard type
	5	With no explosion protection
	E	With explosion protection
	0	Basic type
	3	With ISA Standard G3 option and temperature (-20 to 70 °C) option
Option Codes	/K4A00	With KS Cable Interface Adapter [Model: ATK4A-00]
	/A4S00	With Pressure Clamp Terminal Block for Analog [Model: ATA4S-00]
	/A4S10	With Pressure Clamp Terminal Block for Analog (surge absorber) [Model: ATA4S-10]
	/A4D00	With Dual Pressure Clamp Terminal Block for Analog [Model: ATA4D-00]
	/A4D10	With Dual Pressure Clamp Terminal Block for Analog (surge absorber) [Model: ATA4D-10]
	/CCC01	With Connector Cover for MIL Cable [Model: ACCC01]

		Description
Model	AAB141	Analog Input Module (1 to 5 V/4 to 20 mA, 16-channel, Non-Isolated)
Suffix Codes	-H	With digital communication (HART protocol)
	5	With no explosion protection
	E	With explosion protection
	0	Basic type
	3	With ISA Standard G3 option and temperature (-20 to 70 °C) option
Option Codes	/K4A00	With KS Cable Interface Adapter [Model: ATK4A-00]

		Description
Model	AAI841	Analog I/O Module (4 to 20 mA input , 4 to 20 mA output, 8-channel input/8-channel output, Non-Isolated)
Suffix Codes	-S	Standard type
	-H	With digital communication (HART protocol)
	5	With no explosion protection
	E	With explosion protection
	0	Basic type
Option Codes	3	With ISA Standard G3 option and temperature (-20 to 70 °C) option
	/K4A00	With KS Cable Interface Adapter [Model : ATK4A-00]
	/A4S00	With Pressure Clamp Terminal Block for Analog [Model : ATA4S-00]
	/A4S10	With Pressure Clamp Terminal Block for Analog (surge absorber) [Model : ATA4S-10]
	/A4D00	With Dual Pressure Clamp Terminal Block for Analog [Model : ATA4D-00]
	/A4D10	With Dual Pressure Clamp Terminal Block for Analog (surge absorber) [Model : ATA4D-10]
	/CCC01	With Connector Cover for MIL Cable [Model : ACCC01]

		Description
Model	AAB841	Analog I/O Module (1 to 5 V input, 4 to 20 mA output, 8-channel input/8-channel output, Non-Isolated)
Suffix Codes	-S	Standard type
	5	With no explosion protection
	E	With explosion protection
	0	Basic type
	3	With ISA Standard G3 option and temperature (-20 to 70 °C) option
Option Codes	/K4A00	With KS Cable Interface Adapter [Model : ATK4A-00]
	/M4A00	With MAC2 Compatible Adapter [Model : ATM4A-00]
	/V4A00	With VM2 Compatible Adapter [Model : ATV4A-00] (*1)
	/A4S00	With Pressure Clamp Terminal Block for Analog [Model : ATA4S-00]
	/A4S10	With Pressure Clamp Terminal Block for Analog (surge absorber) [Model : ATA4S-10]
	/A4D00	With Dual Pressure Clamp Terminal Block for Analog [Model : ATA4D-00]
	/A4D10	With Dual Pressure Clamp Terminal Block for Analog (surge absorber) [Model : ATA4D-10]
		/CCC01

*1: When using this adapter, 4 to 20 mA output (8-channel) of AAB841 varies to 1 to 5 V output.

		Description
Model	AAB842	Analog I/O Module (1 to 5 V/4 to 20 mA input, 4 to 20 mA output, 8-channel input/8-channel output, Non-Isolated)
Suffix Codes	-H	With digital communication (HART protocol)
	5	With no explosion protection
	E	With explosion protection
	0	Basic type
	3	With ISA Standard G3 option and temperature (-20 to 70 °C) option
Option Codes	/M4A00	With MAC2 Compatible Adapter [Model : ATM4A-00]
	/V4A00	With VM2 Compatible Adapter [Model : ATV4A-00] (*1)

*1: When using this adapter, 4 to 20 mA output (8-channel) of AAB842 varies to 1 to 5 V output.

		Description
Model	AAV542	Analog Output Module (-10 to +10 V, 16-channel, Non-Isolated)
Suffix Codes	-S	Standard Type
	5	With no explosion protection
	E	With explosion protection
	0	Basic type
	3	With ISA Standard G3 option and temperature (-20 to 70 °C) option
Option Codes	/K4A00	With KS Cable Interface Adapter [Model : ATK4A-00]
	/A4S00	With Pressure Clamp Terminal Block for Analog [Model : ATA4S-00]
	/A4S10	With Pressure Clamp Terminal Block for Analog (surge absorber) [Model : ATA4S-10]
	/A4D00	With Dual Pressure Clamp Terminal Block for Analog [Model : ATA4D-00]
	/A4D10	With Dual Pressure Clamp Terminal Block for Analog (surge absorber) [Model : ATA4D-10]
		/CCC01

		Description
Model	AAI143	Analog Input Module (4 to 20 mA, 16-channel, Isolated)
Suffix Codes	-S	Standard type
	-H	With digital communication (HART protocol)
	5	With no explosion protection
	E	With explosion protection
	0	Basic type
Option Codes	3	With ISA Standard G3 option and temperature (-20 to 70 °C) option
	/K4A00	With KS Cable Interface Adapter (For connecting AEA4D Terminal Board) [Model: ATK4A-00]
	/A4S00	With Pressure Clamp Terminal Block [Model: ATA4S-00]
	/A4S10	With Pressure Clamp Terminal Block (surge absorber) [Model: ATA4S-10]
	/A4D00	With Dual Pressure Clamp Terminal Block [Model: ATA4D-00]
	/A4D10	With Dual Pressure Clamp Terminal Block (surge absorber) [Model: ATA4D-10]
/CCC01	With Connector Cover for MIL Cable [Model: ACCC01]	

		Description
Model	AAI543	Analog Output Module (4 to 20 mA, 16-channel, Isolated)
Suffix Codes	-S	Standard type
	-H	With digital communication (HART protocol)
	5	Standard switch-over response in redundant configuration with no explosion protection(*1)
	6	Fast switch-over response in redundant configuration with no explosion protection(*2)
	E	Standard switch-over response in redundant configuration with explosion protection(*1)
	F	Fast switch-over response in redundant configuration with explosion protection(*2)
	0	Basic type
	1	With ISA Standard G3 option
Option Codes	3	With ISA Standard G3 option and temperature (-20 to 70 °C) option
	/K4A00	With KS Cable Interface Adapter (For connecting AEA4D Terminal Board) [Model: ATK4A-00]
	/A4S00	With Pressure Clamp Terminal Block [Model: ATA4S-00]
	/A4S10	With Pressure Clamp Terminal Block (surge absorber) [Model: ATA4S-10]
	/A4D00	With Dual Pressure Clamp Terminal Block [Model: ATA4D-00]
	/A4D10	With Dual Pressure Clamp Terminal Block (surge absorber) [Model: ATA4D-10]
/CCC01	With Connector Cover for MIL Cable [Model: ACCC01]	

*1: If "standard switch-over response in redundant configuration" is selected, "basic type" or "with ISA Standard G3 option and temperature (-20 to 70 °C) option" may be specified.

*2: If "fast switch-over response in redundant configuration" is selected, "basic type" or "with ISA Standard G3 option" may be specified.

		Description
Model	AAV144	Analog Input Module (-10 to +10 V, 16-channel, Isolated)
Suffix Codes	-S	Standard type
	5	With no explosion protection
	E	With explosion protection
	0	Basic type
Option Codes	3	With ISA Standard G3 option and temperature (-20 to 70 °C) option
	/K4A00	With KS Cable Interface Adapter [Model: ATK4A-00]
	/A4S00	With Pressure Clamp Terminal Block for Analog [Model: ATA4S-00]
	/A4S10	With Pressure Clamp Terminal Block for Analog (surge absorber) [Model: ATA4S-10]
	/A4D00	With Dual Pressure Clamp Terminal Block for Analog [Model: ATA4D-00]
	/A4D10	With Dual Pressure Clamp Terminal Block for Analog (surge absorber) [Model: ATA4D-10]
	/CCC01	With Connector Cover for MIL Cable [Model: ACCC01]

		Description
Model	AAV544	Analog Output Module (-10 to +10 V, 16-channel, Isolated)
Suffix Codes	-S	Standard Type
	5	With no explosion protection
	E	With explosion protection
	0	Basic type
	3	With ISA Standard G3 option and temperature (-20 to 70 °C) option
Option Codes	/K4A00	With KS Cable Interface Adapter [Model : ATK4A-00]
	/A4S00	With Pressure Clamp Terminal Block for Analog [Model : ATA4S-00]
	/A4S10	With Pressure Clamp Terminal Block for Analog (surge absorber) [Model : ATA4S-10]
	/A4D00	With Dual Pressure Clamp Terminal Block for Analog [Model : ATA4D-00]
	/A4D10	With Dual Pressure Clamp Terminal Block for Analog (surge absorber) [Model : ATA4D-10]
	/CCC01	With Connector Cover for MIL Cable [Model : ACCC01]

		Description
Model	AAT141	TC/mV Input Module (16-channel, Isolated)
Suffix Codes	-S	Standard type
	5	With no explosion protection
	E	With explosion protection
	0	Basic type
	3	With ISA Standard G3 option and temperature (-20 to 70 °C) option
Option Codes	/T4S00	With Pressure Clamp Terminal Block for Thermocouple/mV [Model: ATT4S-00]
	/T4S10	With Pressure Clamp Terminal Block for Thermocouple/mV (surge absorber) [Model: ATT4S-10]
	/T4D00	With Dual Pressure Clamp Terminal Block for Thermocouple/mV [Model: ATT4D-00]
	/T4D10	With Dual Pressure Clamp Terminal Block for Thermocouple/mV (surge absorber) [Model: ATT4D-10]
	/CCC01	With Connector Cover for MIL Cable [Model: ACCC01]

		Description
Model	AAR181	RTD Input Module (12-channel, Isolated)
Suffix Codes	-S	Standard type
	5	With no explosion protection
	E	With explosion protection
	0	Basic type
	3	With ISA Standard G3 option and temperature (-20 to 70 °C) option
Option Codes	/R8S00	With Pressure Clamp Terminal Block for RTD [Model: ATR8S-00]
	/R8S10	With Pressure Clamp Terminal Block for RTD (surge absorber) [Model: ATR8S-10]
	/R8D00	With Dual Pressure Clamp Terminal Block for RTD [Model: ATR8D-00]
	/R8D10	With Dual Pressure Clamp Terminal Block for RTD (surge absorber) [Model: ATR8D-10]
	/CCC01	With Connector Cover for MIL Cable [Model: ACCC01]

		Description
Model	AAI135	Analog Input Module (4 to 20 mA, 8-channel, Isolated channels)
Suffix Codes	-S	Standard type
	-H	With digital communication (HART protocol)
	5	With no explosion protection
	E	With explosion protection
	0	Basic type
	3	With ISA Standard G3 option and temperature (-20 to 70 °C) option
Option Codes	/I3A00	With KS Cable Interface Adapter [Model: ATI3A-00]
	/K4A00	With KS Cable Interface Adapter [Model: ATK4A-00]
	/I3S00	With Pressure Clamp Terminal Block for Isolated Analog [Model: ATI3S-00]
	/I3S10	With Pressure Clamp Terminal Block for Isolated Analog (surge absorber) [Model: ATI3S-10]
	/I3D00	With Dual Pressure Clamp Terminal Block for Isolated Analog [Model: ATI3D-00]
	/I3D10	With Dual Pressure Clamp Terminal Block for Isolated Analog (surge absorber) [Model: ATI3D-10]
	/CCC01	With Connector Cover for MIL Cable [Model: ACCC01]

		Description
Model	AAI835	Analog I/O Module (4 to 20 mA, 4-channel input/4-channel output, Isolated channels)
Suffix Codes	-S	Standard type
	-H	With digital communication (HART protocol)
	5	With no explosion protection
	E	With explosion protection
	0	Basic type
	3	With ISA Standard G3 option and temperature (-20 to 70 °C) option
Option Codes	/B3A00	With KS Cable Interface Adapter [Model: ATB3A-00]
	/K4A00	With KS Cable Interface Adapter [Model: ATK4A-00]
	/13S00	With Pressure Clamp Terminal Block for Isolated Analog [Model: ATI3S-00]
	/13S10	With Pressure Clamp Terminal Block for Isolated Analog (surge absorber) [Model: ATI3S-10]
	/13D00	With Dual Pressure Clamp Terminal Block for Isolated Analog [Model: ATI3D-00]
	/13D10	With Dual Pressure Clamp Terminal Block for Isolated Analog (surge absorber) [Model: ATI3D-10]
	/CCC01	With Connector Cover for MIL Cable [Model: ACCC01]

		Description
Model	AAT145	TC/mV Input Module (16-channel, Isolated channels)
Suffix Codes	-S	Standard type
	5	With no explosion protection
	E	With explosion protection
	0	Basic type
	3	With ISA Standard G3 option and temperature (-20 to 70 °C) option

		Description
Model	AAR145	RTD/POT Input Module (16-channel, Isolated channels)
Suffix Codes	-S	Standard type
	5	With no explosion protection
	E	With explosion protection
	0	Basic type
	3	With ISA Standard G3 option and temperature (-20 to 70 °C) option

		Description
Model	AAP135	Pulse Input Module (8-channel, Pulse count, 0 to 10 kHz, Isolated channels)
Suffix Codes	-S	Standard type
	5	With no explosion protection
	E	With explosion protection
	0	Basic type
	3	With ISA Standard G3 option and temperature (-20 to 70 °C) option
Option Codes	/13A00	With KS Cable Interface Adapter [Model: ATI3A-00]
	/K4A00	With KS Cable Interface Adapter [Model: ATK4A-00]
	/13S00	With Pressure Clamp Terminal Block for Pulse [Model: ATI3S-00]
	/13S10	With Pressure Clamp Terminal Block for Pulse (surge absorber) [Model: ATI3S-10]
	/13D00	With Dual Pressure Clamp Terminal Block for Pulse [Model: ATI3D-00]
	/13D10	With Dual Pressure Clamp Terminal Block for Pulse (surge absorber) [Model: ATI3D-10]
	/CCC01	With Connector Cover for MIL Cable [Model: ACCC01]

		Description
Model	AAP149	Pulse Input Module PM1 compatible (16-channel, Pulse count, 0 to 6 kHz, Non-Isolated)
Suffix Codes	-S	Standard type
	0	Always 0
	0	Basic type
	1	With ISA Standard G3 option

		Description
Model	AAP849	Pulse Input Module/ Analog Output Module for compatible PAC (Pulse count Input, 4 to 20 mA output, 8-channel input / 8-channel output, Non-Isolated)
Suffix Codes	-S	Standard type
	0	Always 0
	0	Basic type
	1	With ISA Standard G3 option

■ ORDERING INFORMATION

Specify the model and suffix codes.

For selecting the right products for explosion protection, please refer to TI 33Q01J30-01E without fail.

■ TRADEMARKS

- CENTUM is a registered trademark of Yokogawa Electric Corporation.
- HART is a registered trademark of the HART Communication Foundation.
- Other company and product names appearing in this document are trademarks or registered trademarks of their respective holders.