



Price\* : 398.00 USD



## Main

Range of product	Modicon X80
Product or component type	Discrete output module
Product specific application	For severe environments
Electrical connection	20-way connector
Discrete output number	8 conforming to EN/IEC 61131-2
Discrete output type	Relay
Discrete output voltage	12...24 V 10...34 V DC 24...240 V 10...264 V AC

## Complementary

[I <sub>th</sub> ] conventional free air thermal current	3 A
Insulation resistance	> 10 MOhm 500 V DC
Power dissipation in W	<= 2.7 W
Response time on output	<= 10 ms activation <= 8 ms deactivation
Typical current consumption	100 mA at 3.3 V DC
MTBF reliability	1573341 H
Protection type	Overvoltage protection, inductive AC network Overvoltage protection, inductive DC network External overload protection External short-circuit protection
Output overload protection	Use 1 fast blow fuse per channel or group of channel
Output overvoltage protection	Use discharge diode on each output DC Use RC circuit on each output AC Use ZNO surge limiter on each output AC
Output short-circuit protection	Use 1 fast blow fuse per channel or group of channel
Minimum switching current	1 mA 5 V DC

Electrical durability	1000000 cycles AC-12 30 VA 48 V at 158 °F (70 °C) 1000000 cycles DC-12 14.4 VA 24 V at 158 °F (70 °C) 1000000 cycles DC-13 14.4 VA 24 V at 158 °F (70 °C) 2000000 cycles AC-15 14.4 VA 48 V 0.35 at 158 °F (70 °C) 2000000 cycles DC-13 6 VA 24 V at 158 °F (70 °C) 3000000 cycles DC-12 24 VA 24 V at 158 °F (70 °C) 5000000 cycles AC-12 66 VA 48 V at 158 °F (70 °C) 5000000 cycles AC-15 14.4 VA 24 V 0.35 at 158 °F (70 °C) 5000000 cycles AC-15 6 VA 48 V 0.35 at 158 °F (70 °C) 700000 cycles AC-12 30 VA 24 V at 158 °F (70 °C) 100000 cycles AC-15 132 VA 200...240 V at 158 °F (70 °C) 100000 cycles AC-15 220 VA 200...240 V 0.35 at -13...140 °F (-25...60 °C) 1000000 cycles AC-12 110 VA 110...120 V at -13...140 °F (-25...60 °C) 1000000 cycles AC-12 132 VA 200...240 V at 158 °F (70 °C) 1000000 cycles AC-12 220 VA 200...240 V at -13...140 °F (-25...60 °C) 1000000 cycles AC-12 50 VA 48 V at -13...140 °F (-25...60 °C) 1000000 cycles AC-12 66 VA 110...120 V at 158 °F (70 °C) 1000000 cycles AC-15 110 VA 200...240 V 0.35 at -13...140 °F (-25...60 °C) 1000000 cycles AC-15 60 VA 200...240 V at 158 °F (70 °C) 1000000 cycles DC-12 24 W 24 V at -13...140 °F (-25...60 °C) 1000000 cycles DC-13 24 W 24 V at -13...140 °F (-25...60 °C) 10000000 cycles AC-15 10 VA 110...120 V 0.35 at -13...140 °F (-25...60 °C) 10000000 cycles AC-15 10 VA 200...240 V 0.35 at -13...140 °F (-25...60 °C) 10000000 cycles AC-15 6 VA 110...120 V 0.35 at 158 °F (70 °C) 10000000 cycles AC-15 6 VA 200...240 V at 158 °F (70 °C) 1500000 cycles AC-15 110 VA 110...120 V 0.35 at -13...140 °F (-25...60 °C) 1500000 cycles AC-15 60 VA 110...120 V 0.35 at 158 °F (70 °C) 1500000 cycles AC-15 30 VA 110...120 V 0.35 at 158 °F (70 °C) 1500000 cycles AC-15 50 VA 110...120 V 0.35 at -13...140 °F (-25...60 °C) 2000000 cycles AC-15 24 VA 48 V 0.35 at -13...140 °F (-25...60 °C) 2000000 cycles DC-13 10 W 24 V at -13...140 °F (-25...60 °C) 3000000 cycles DC-12 40 W 24 V at -13...140 °F (-25...60 °C) 3000000 cycles AC-15 30 VA 200...240 V at 158 °F (70 °C) 3000000 cycles AC-15 50 VA 200...240 V 0.35 at -13...140 °F (-25...60 °C) 500000 cycles AC-12 110 VA 48 V at -13...140 °F (-25...60 °C) 500000 cycles AC-12 132 VA 110...120 V at 158 °F (70 °C) 500000 cycles AC-12 220 VA 110...120 V at -13...140 °F (-25...60 °C) 500000 cycles AC-15 10 VA 48 V 0.35 at -13...140 °F (-25...60 °C) 500000 cycles AC-15 24 VA 24 V 0.35 at -13...140 °F (-25...60 °C) 700000 cycles AC-12 50 VA 24 V at -13...140 °F (-25...60 °C)
Status LED	1 LED green module operating (RUN) 1 LED per channel green channel diagnostic 1 LED red module I/O 1 LED red module error (ERR)
Product weight	0.32 lb(US) (0.145 kg)

## Environment

IP degree of protection	IP20
Product certifications	IEC-Ex CSA ATEX UL EAC Merchant Navy RCM CE
Standards	EN/IEC 61010-2-201 EN/IEC 61131-2 CSA C22.2 No 61010-2-201 UL 61010-2-201
Dielectric strength	2000 V AC at 50/60 Hz 1 min
Vibration resistance	3 gn
Shock resistance	30 gn
Ambient air temperature for storage	-40...185 °F (-40...85 °C)
Ambient air temperature for operation	-13...158 °F (-25...70 °C)
Relative humidity	5...95 % without condensation 55 °C
Protective treatment	TC Conformal coating Humiseal 1A33
Environmental characteristic	Corrosion resistance

Dust resistant

Operating altitude	0...6561.68 ft (0...2000 m) 2000...5000 m (with derating factor)
--------------------	---

### Ordering and shipping details

Category	18160 - MODICON M340
Discount Schedule	PC34
GTIN	00785901340300
Nbr. of units in pkg.	1
Package weight(Lbs)	0.4199999999999998
Returnability	Y
Country of origin	FR

### Offer Sustainability

Sustainable offer status	Green Premium product
RoHS (date code: YYWW)	Compliant - since 0901 - Schneider Electric declaration of conformity <a href="#">Schneider Electric declaration of conformity</a>
REACH	Reference not containing SVHC above the threshold <a href="#">Reference not containing SVHC above the threshold</a>
Product environmental profile	Available
Product end of life instructions	Available

### Contractual warranty

Warranty period	18 months
-----------------	-----------

Modules Mounted on Racks

Dimensions

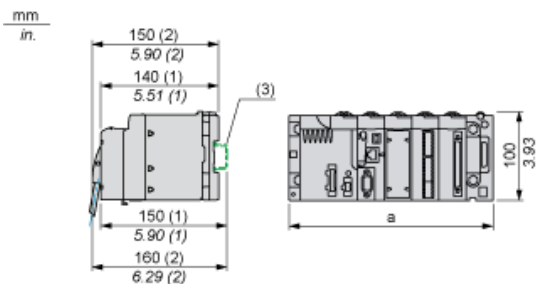

- (1) With removable terminal block (cage, screw or spring).
- (2) With FCN connector.
- (3) On AM1 ED rail: 35 mm wide, 15 mm deep. Only possible with BMXXBP0400/0400H/0600/0600H/0800/0800H rack.

Rack references	a in mm	a in in.
BMXXBP0400 and BMXXBP0400H	242.4	09.54
BMXXBP0600 and BMXXBP0600H	307.6	12.11
BMXXBP0800 and BMXXBP0800H	372.8	14.68
BMXXBP1200 and BMXXBP1200H	503.2	19.81

Connecting the Module

Output Circuit Diagram

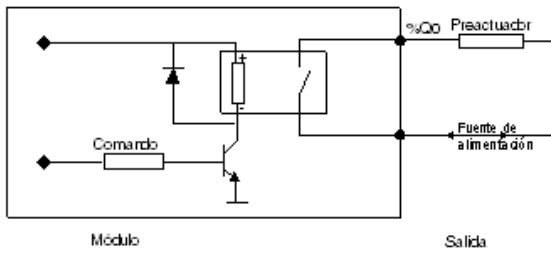

Module Connection

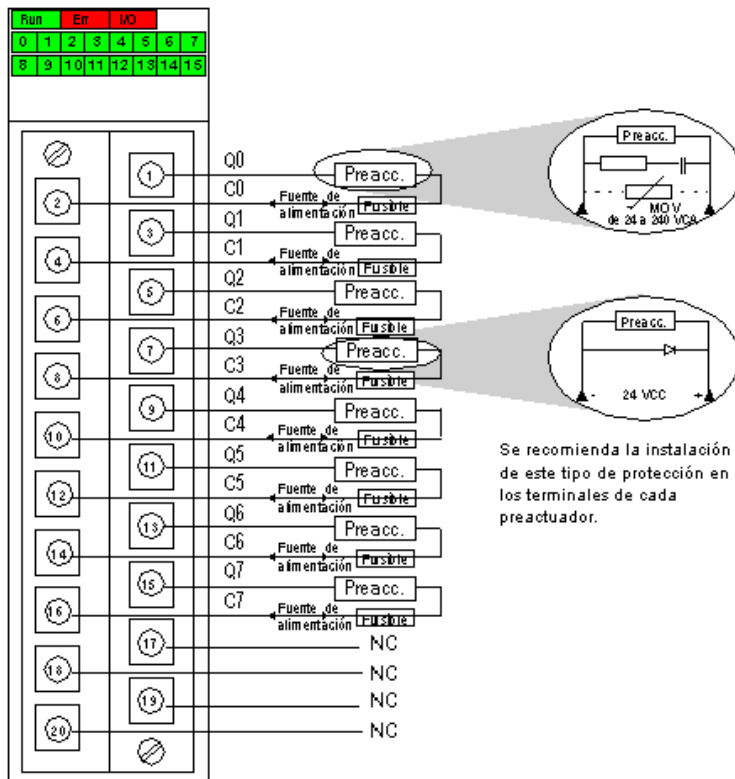

power supply 24VDC or 24...240 VAC  
 fuse 1 fast blow fuse of 3 A for each relay  
 NC not connected