

TZIDC-120

Electro-Pneumatic Positioner

Compact, well-proven, and flexible



For FOUNDATION Fieldbus

Compact and efficient

- With proven technology and intelligence

Communication-ready for FOUNDATION Fieldbus

- Fieldbus connection acc. to IEC 61158-2
- Power consumption 11.5 mA, 9 ... 32 V DC

Easy to commission, user-friendly

- Fully automatic autoadjust
- Setup via integrated operator panel or remote configuration
- Mechanical position indicator

EMV and CE conformity

Robust and environmentally ruggedized

- Shock and vibration influence < 1 %
- Aluminum housing, protection class IP 65

Additional temperature range

- -40 ... 85 °C (-40 ... 185 °F)

Mounting on pneumatic linear actuators or rotary actuators

Optional with pressure gauge block and filter regulator

Low operating cost

- Air consumption < 0.03 kg/h

ATEX, FM, CSA, GOST and IECEx approvals

Contents

1	Description	3
1.1	Pneumatics.....	3
1.2	Operation.....	3
1.3	Communication	3
1.4	Modular design.....	3
2	Mounting versions	5
2.1	To linear actuators in accordance with the standard	5
2.2	To rotary actuators in accordance with the standard	5
2.3	Integral mounting to control valves	5
2.4	Special actuator-specific mounting	5
3	Operation	7
3.1	General.....	7
3.2	Operator panel	8
4	Communication	9
4.1	General.....	9
4.2	Configuration	9
4.3	FOUNDATION Fieldbus H1	9
4.4	Benefits of FF communication.....	9
4.5	FF communication for TZIDC-220.....	9
5	Specifications	10
5.1	Communication	10
5.2	Designation	10
5.3	Output.....	10
5.4	Travel.....	10
5.5	Air supply.....	10
5.6	Transmission data and influences.....	11
5.7	Environmental capabilities	11
5.8	Housing	11
5.9	Explosion protection	12
5.10	Options	12
5.11	Accessories	13
6	Electrical connections	14
7	Dimensions	16
8	Ordering information	19
8.1	Accessories	20

1 Description

The TZIDC-120 is an electronically configurable positioner with communication capabilities designed for mounting to pneumatic linear or rotary actuators. It features a small and compact design, a modular construction, and an excellent cost-performance ratio.

Fully automatic determination of the control parameters and adaptation to the final control element yield considerable time savings and an optimal control behavior.

1.1 Pneumatics

An I/P module with subsequent pneumatic amplifier is used to control the pneumatic actuator. The well-proven I/P module proportionally converts the permanent electrical setpoint signal from the CPU into a pneumatic signal used to adjust a 3/3-way valve.

The air flow for pressurizing or depressurizing the actuator is continuously adjusted. As a result, excellent control is achieved. When reaching the set point, the 3/3-way valve is closed in center position to minimize the air consumption.

Four different pneumatics versions are available: for single-acting or double-acting actuators, each with "fail-safe" or "fail-freeze" function.

1.1.1 "Fail-safe" function

If the electrical power supply fails, the positioner output 1 is depressurized, and the pneumatic actuator's return spring moves the valve to the defined safe position. In case of a double-acting actuator the second output 2 is additionally pressurized.

1.1.2 "Fail-freeze" function

If the electrical power supply should fail, the positioner output 1 (and 2, if applicable) is closed and the pneumatic actuator stops ("freezes") the valve in the current position. If compressed air supply should fail, the positioner depressurizes the actuator.

1.2 Operation

The positioner has a built-in operating panel providing a 2-line LCD and 4 pushbuttons for optimal local configuration, commissioning and operational monitoring.

Alternatively, the appropriate configuration program and the available communication option can be used.

1.3 Communication

Communication with the TZIDC-120 positioner occurs via FOUNDATION Fieldbus.

1.4 Modular design

The TZIDC-120 basic model can be enhanced at any time by retrofitting optional equipment. Option modules for analog or digital position feedback or a shutdown-module can be installed. Additionally, a mechanical position indicator, proximity switches or 24 V microswitches are available for indicating the position independently of the mother board function.

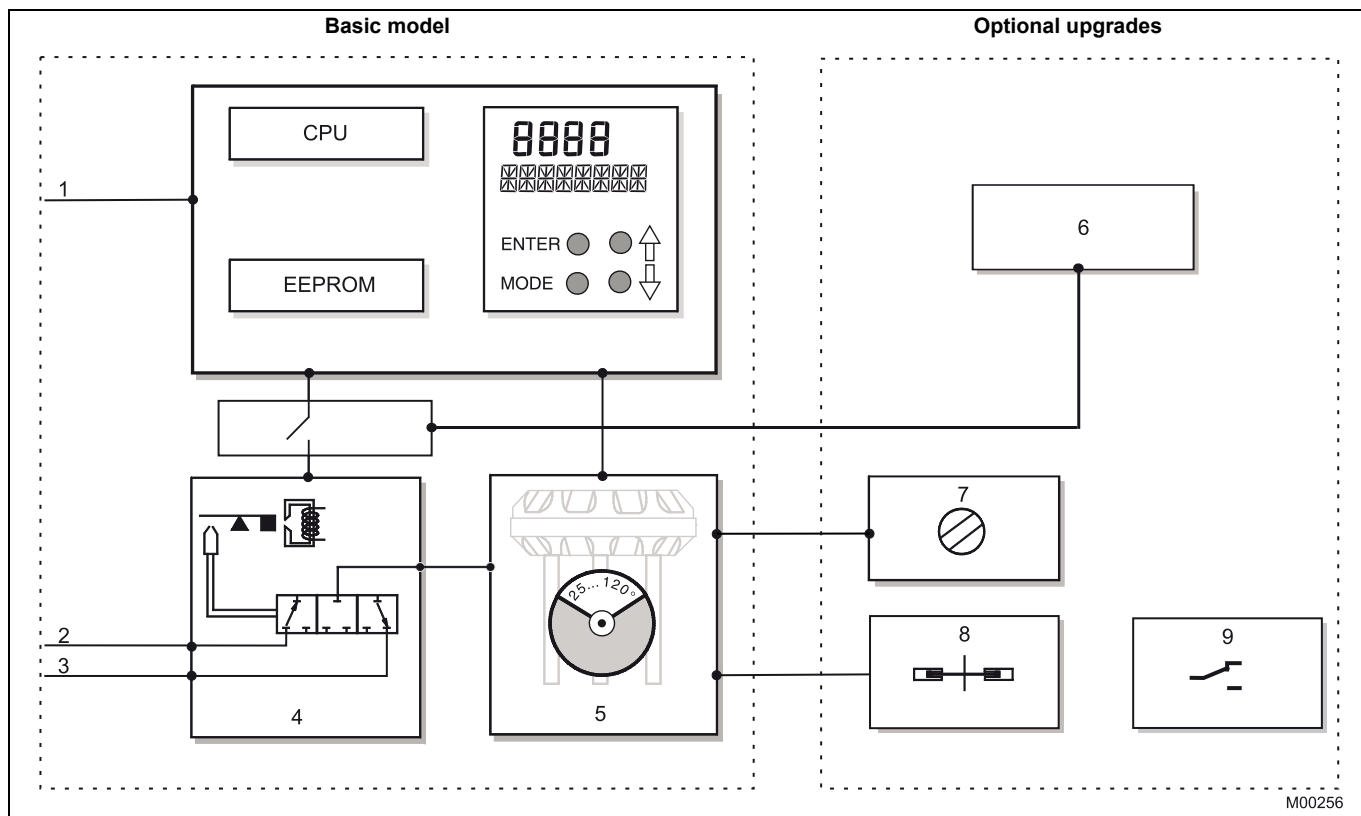

Fig. 1: TZIDC-120 schematic diagram

Basic model

- 1 Bus connector
- 2 Supply, 1.4 ... 6 bar
- 3 Exhaust
- 4 I/P module with 3/3-way valve
- 5 Position sensor (optional up to 270° rotation angle)

Optional upgrades

- 6 Plug-in module for safety shutdown (forced depressurization)
- 7 Mechanical position indicator
- 8 Mechanical feedback with proximity switches
- 9 Mechanical feedback with microswitches 24 V



Important

With optional upgrades either the “mechanical feedback with proximity switches” (8) or the “mechanical feedback with microswitches 24 V” (9) can be used.

In both cases, the “mechanical position indicator” (7) must be installed.

2 Mounting versions

2.1 To linear actuators in accordance with the standard

Lateral attachment is in accordance with DIN / IEC 534 (lateral attachment to NAMUR). The required attachment kit is a complete set of attachment material, but does not include the screwed pipe connections and air pipes.

2.2 To rotary actuators in accordance with the standard

This attachment is designed for mounting according to the standard VDI/VDE 3845. The attachment kit consists of a console with mounting screws for mounting on a rotary actuator. The adapter for coupling the positioner feedback shaft to the actuator shaft has to be ordered separately. Screwed pipe connections and air pipes have to be provided on site.

2.3 Integral mounting to control valves

The TZIDC-120 positioner featuring standard pneumatic action is available as an option for integral mounting.

The required holes are found at the back of the device.

The benefit of this design is that the point for mechanical stroke measurement is protected and that the positioner and actuator are linked internally. No external tubing is required.

2.4 Special actuator-specific mounting

In addition to the mounting methods described above, there are special actuator-specific attachments.

Please contact us for details.

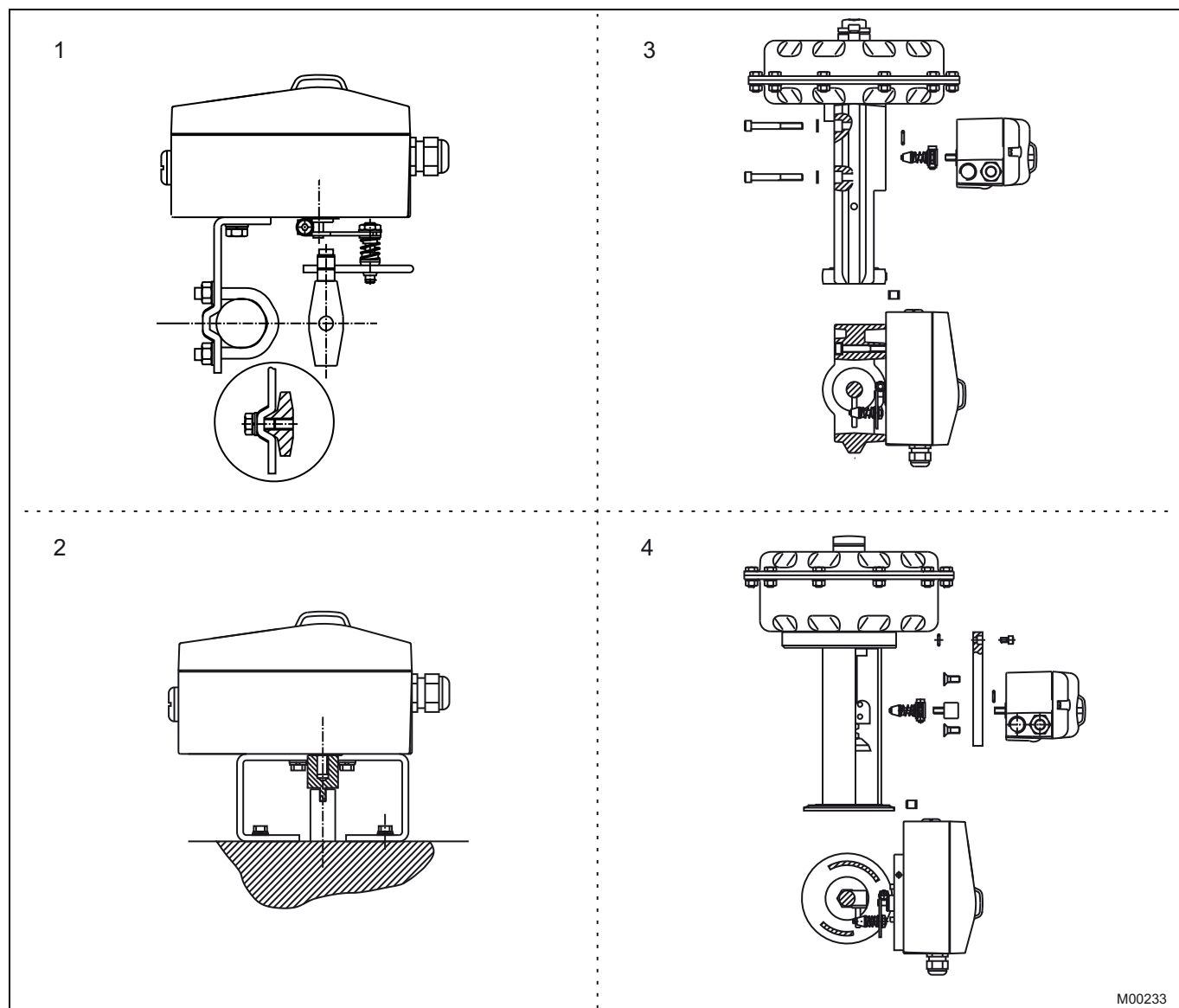

M00233

Fig. 2: Mounting options

- 1 Mounting to linear actuators acc. to DIN / IEC 534
- 2 Mounting to rotary actuators to VDI / VDE 3845

- 3 Integral mounting to control valves
- 4 Integral mounting to control valves by using an adapter panel

3 Operation

3.1 General

The intelligent, microprocessor-controlled TZIDC-120 positioner allows you to obtain optimal results. The positioner features high-precision control functions and high operational reliability. The optimal parameters are set automatically during autoadjust. If necessary, corrections can be made manually.

The total range of parameters includes:

- Operating parameters
- Adjustment parameters
- Monitoring parameters

3.1.1 Operating parameters

The following operating parameters can be activated and configured:

Characteristic curve (travel = f {signal})

Linear, equal percentage 1:25 or 1:50 or 25:1 or 50:1 or freely configurable with 20 reference points.

Tolerance band

When the tolerance band is reached, the position is considered as corrected. From this point on, the position is further slowly re-adjusted until the dead band is reached. The factory setting for this parameter is 0.3 %.

Dead band (sensitivity)

When reaching the dead band, the position is held. The factory setting for this parameter is 0,1 %. The tolerance band and dead zone are automatically calculated as part of the controller's self-optimization process.

Travel limit

The positioning travel, i.e. the stroke or angle of rotation, can be reduced as required within the full range of 0 ... 100 %, provided that a minimum value of 20 % is observed.

Shut-off function

This function can be selected separately for each end position. When the respective configured limit value is exceeded, the shut-off function causes the actuator to travel immediately to the selected end position.

Travel time prolongation

This function can be used to increase the max. travel time for full travel. This time parameter can be set separately for each direction.



Important

This function can only be used with the pneumatics with the safety function "fail-safe".

Rules in end position

For both end positions, you can select whether the pneumatic actuator is vented fully or whether the position is controlled.

3.1.2 Adjustment parameters

The TZIDC-120 positioner has a special function for automatic adjustment of the parameters. The function is launched either via the integrated operator's panel or the user interface.

The following adjustment parameters can be activated and configured:

Parameters for control block

To optimally adjust the actuator position, the control parameters can be set individually for the control behavior of the valve.

Range 0 ... 100 %

Configuration of end positions for the valve to be adjusted to start position "0" and end position "100 %".

Direction of the actuator

Calibration to both possible directions of action:

Air opens / spring force closes

or

Air closes / spring force opens

Display 0 ... 100 %

Adjusting the display (0 ... 100 %) to the direction of action for opening or closing the valve.

3.1.3 Monitoring parameters

Various functions for permanent operational monitoring are implemented in the TZIDC-120 operating program, e.g.:

- Internal positioning time-out
- Sensor monitoring
- Backup monitoring

While automatic commissioning is in progress, the current state is continuously indicated on the integrated LCD. Remaining messages can be retrieved via the user interface.

The fieldbus enables users to implement enhanced monitoring in the control system. A special window displays the most important process variables ONLINE such as the positioning signal (in %), the position (in %), the control deviation (in %) as well as the status messages.

3.2 Operator panel

The TZIDC-120 positioner's operator panel with four pushbuttons allows for

- operational monitoring
- manual control
- configuration
- fully automatic commissioning

The operator panel is protected by a cover which avoids unauthorized access to the operating elements.

3.2.1 Single-button commissioning

Commissioning the TZIDC-120 positioner is especially easy. The standard Autoadjust function for automatic adaptation of the device parameters can be started by simply pressing a single front panel button, and without knowing parameterization details.

Depending on the selected actuator type (linear or rotary), the displayed zero position is automatically adapted:

- for linear actuators counter-clockwise (CTCLOCKW)
- for rotary actuators clockwise (CLOCKW).

Besides this standard function, a customized "Autoadjust" function is available. The function is launched either via the operator's panel or the configuration program.

3.2.2 Operation

The four pushbuttons enable users to select operating levels, configure the device and store settings. In addition to the known operating functions, a simplified autoadjust can be performed. This enables you to launch the device's automatic configuration function in a few steps and without detailed knowledge regarding parameters.

When changing the actuator type from linear to rotary, the zero position of the display is automatically updated. This is indicated in the display for valves closing on the right in the closed position 0 %.

3.2.3 Display

The information indicated by the 2-line LCD is permanently updated and adapted during operation, to inform the operator in an optimal way.

During control operation the following TZIDC-120 data can be called up by pressing the pushbuttons briefly:

Up button	Cyclic communication:
	- Setpoint (%)
	- Setpoint status
	Acyclic communication:
	- Status of communication
Down button	Operating mode on the bus and bus address
Enter	Software Version



Fig. 3: TZIDC-120 with removed cover, view of the operator panel

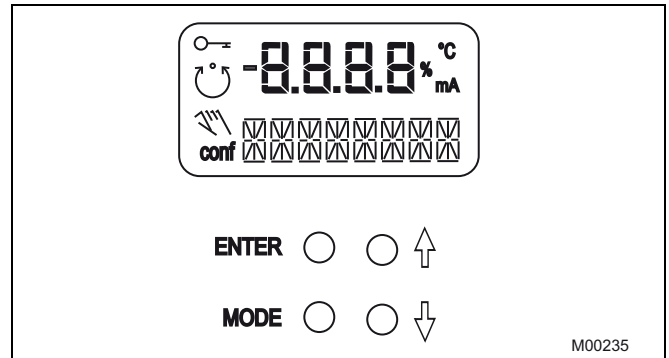

Fig. 4: TZIDC-120 operating elements and display

4 Communication

4.1 General

Communication occurs via the fieldbus connection. In conformance with bus convention, device data is read in cyclic operation (operating mode AUT, MAN or RCAS) and data is written in the O/S (out-of-service) mode. Newly set parameters are saved in the non-volatile memory directly after writing to the field device, and become active immediately.

FOUNDATION Fieldbus is an open bus standard that enables users to integrate devices from various manufacturers in a system and supports interoperability.

Communication occurs via an FF system using the fast, superordinate HSE bus (high-speed ethernet) and the slower but intrinsically safe H1 bus. It is layer-oriented and based on the ISO/OSI model (International Standards Organization's Open System Interconnect).

A device description (DD) provided in file format by the manufacturer contains all the necessary information on the FF device and its functions.

4.2 Configuration

The user interface for the TZIDC-120 positioner is integrated in the control system. This allows you to work with the fieldbus in the commissioning phase, during operation and for service tasks when monitoring the device, setting parameters and uploading data.

4.3 FOUNDATION Fieldbus H1

The FOUNDATION Fieldbus H1 was developed primarily for use in process automation. The transmission method (physical layer) complies with IEC 61158. The power supply for the field devices is provided concurrent with signal transmission via the fieldbus line. FOUNDATION Fieldbus H1 is also well suited for use in explosion-proof installations.

4.4 Benefits of FF communication

- Standardized function blocks and an interoperability test ensure smooth integration of devices from various manufacturers
- Acyclic access to device data (even during operation) for configuration, diagnostics and service
- High system uptimes based on comprehensive device and bus diagnostics as well as default value strategies in the event of an error
- Support for efficient facility management through provision of operating values

4.5 FF communication for TZIDC-120

Using the FOUNDATION Fieldbus in combination with a suitable configuration program installed in the control system, the TZIDC-120 can be easily monitored, configured and queried. Newly set parameters are saved in the non-volatile memory directly upon download to the device, and become active immediately.

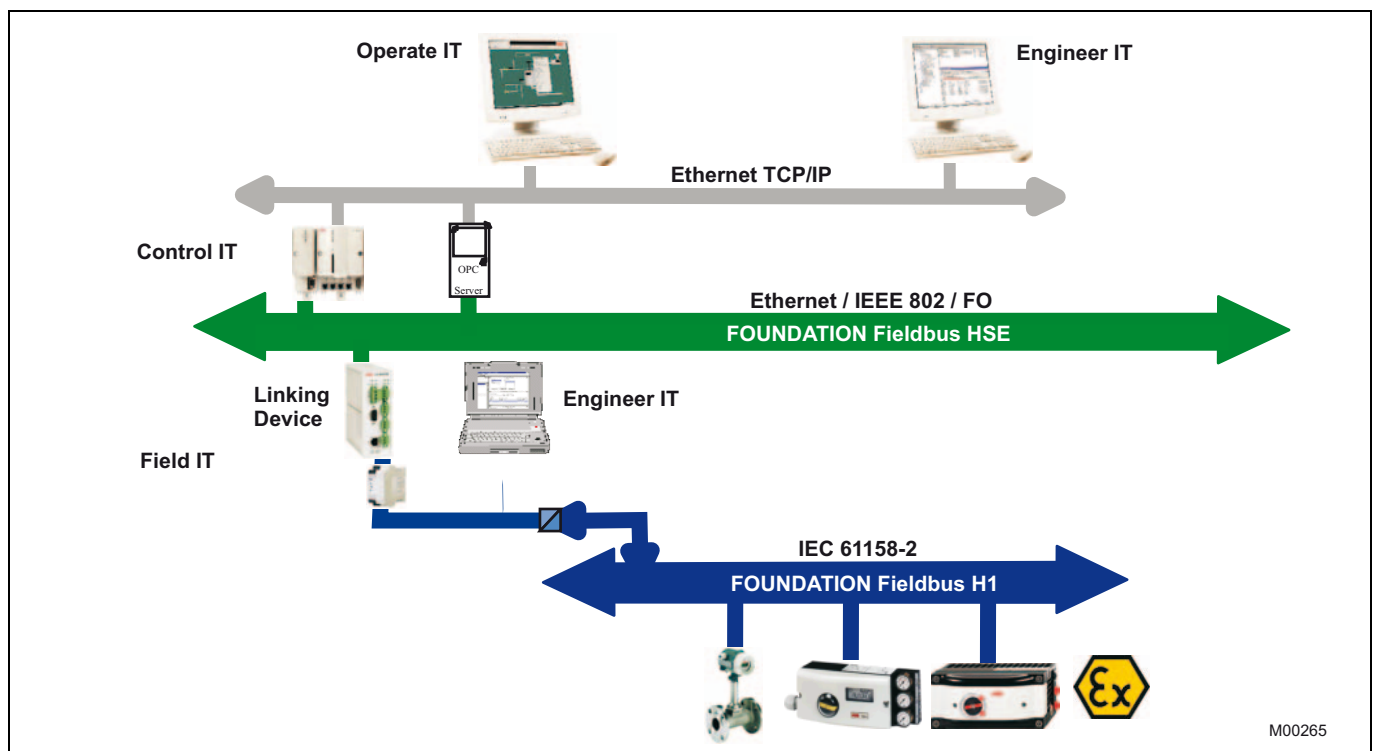

Fig. 5: Communication via FOUNDATION Fieldbus

5 Specifications

5.1 Communication

Specification	FOUNDATION Fieldbus, version 1.5
Physical Layer	Model 113, 121 (IEC 61158-2)
Transmission rate	31.25 Kbit/s
Block types	1 AO Function block 1 PID block 1 Resource block 1 Transducer block 1 physical block
Block class	AO block: standard PID block: enhanced Resource block: enhanced Transducer block: custom
Number of linkage objects	22
Device description (DD)	Rev. No. 1 (file name 0201.ffo, 0201.sym)
File	Common file format (file name: 020101.cff)
Max. execution time	AO block: 40 milliseconds PID block: 50 milliseconds
Supply voltage	Power feed from the fieldbus 9.0 ... c 32.0 V DC
Max. permissible voltage	35 V DC
Power consumption	11.5 mA
Current in the event of an error	15 mA (11.5 mA + 3.5 mA)
FF Certification	Registered with ITK 4.51, Dec.2003 IT Camp. Number IT023200
Device name	ABB TZIDC-120-TAG
Dev. ID	0003200028-TZIDC-120XXXXXXXXXX
Device address	Between 10 and 247, default address 23
ATEX certificate for FISCO	Yes
Insensitive to reversed polarity	Yes
Class	LM profile 32L, 31 PS
Factory default	The positioner is not delivered in an aligned state. To adjust the operating range and control parameters, an automatic configuration must be run on the unit. Otherwise, the transducer block remains in out-of-service mode.
Diagnostic functions	Self-diagnostics for the positioner hardware and software, valve diagnostics with enhanced alarm handling

5.2 Designation

Device name	ABB TZID-C120-TAG
Dev. ID	0003200028-TZID-C120XXXXXXXXXX

5.3 Output

Range	0 ... 6 bar (0 ... 90 psi)
Air capacity at 1.4 bar (20 psi) supply pressure	5.0 kg/h = 3.9 Nm ³ /h = 2.3 scfm
at 6 bar (90 psi) supply pressure	13 kg/h = 10 Nm ³ /h = 6.0 scfm
Output function	For single or double-acting actuators, air is vented from actuator or actuator is blocked in case of (electrical) power failure
Shut-off values	End Position 0 % = 0 ... 45 % End position 100 % = 55 ... 100 %

5.4 Travel

Rotation angle Used range	
25 ... 120°	rotary actuators, optionally 270°
25 ... 60°	linear actuators

Travel time prolongation

Setting range	0 ... 200 seconds, separately for each direction
---------------	--

5.5 Air supply

Instrument air	free of oil, water and dust to DIN/ISO 8573-1. Pollution and oil content according to Class 3 (purity: max. particle size = 5 µm, max. particle density = 5 mg / m ³ ; oil content: max. concentration = 1 mg / m ³ ; pressure dew point: 10 K below operating temperature)
Supply pressure	1.4 ... 6 bar (20 ... 90 psi)



Important

Do not exceed the maximum operating pressure of the actuator!

Air consumption	< 0.03 kg/h / 0.015 scfm (independent of supply pressure)
------------------------	---

5.6 Transmission data and influences

Direction of action (output signal or pressure in actuator)

Increasing	Increasing output signal 0 ... 100 % Increasing pressure y1 in the actuator
Decreasing	Increasing output signal 0 ... 100 % Decreasing pressure y1 in the actuator

Characteristic deviation	< 0.5 %
Tolerance band	0.3 ... 10 %, adjustable
Dead band	0.1 ... 5 %, adjustable
Resolution (A/D conversion)	> 16000 steps
Sample rate	20 ms
Influence of ambient temperature	< 0.5 % for each 10 K
Influence of vibration	$\leq \pm 1$ % to 10 g and 80 Hz

Seismic requirements

Meets requirements of DIN / IEC 68-3-3 Class III for strong and strongest earthquakes.

Influence of mounting orientation

Not measurable.

Meets the requirements of the following directives

- EMC Directive 2004/108/EC as of December 2004
- EC Directive for CE conformity marking

5.7 Environmental capabilities

Ambient temperature

For operation, storage and transport:	-40 ... 85 °C (-40 ... 185 °F)
When using proximity switches SJ2-S1N (NO):	-25 ... 85 °C (-13 ... 185 °F)

Relative humidity

Operational (with closed housing and air supply switched on):	95 % (annual average), condensation permissible
Transport and storage:	75 % (annual average), non- condensing

5.8 Housing

Material / protection

Aluminum, protection class IP 65 (optional IP 66) / NEMA 4X

Surface / color

Electrostatic dipping varnish with epoxy resin, stove-hardened. Case varnished black, RAL 9005, matte, housing cover Pantone 420.

Electrical connections

Screw terminals: Max. 1.0 mm² (AWG 17) for options
Max. 2.5 mm² (AWG 14) for bus connector



Important

Do not expose the terminals to strain.

Cable entry: 2 cable glands 1/2-14 NPT or M20 x 1.5
(1 x with cable gland and 1 x with pipe plug)

Pneumatic connections

Threads G 1/4 or 1/4-18 NPT

Weight

1.7 kg (3.75 lb)

Mounting orientation

any

5.9 Explosion protection

Important

The values indicated here are taken from the respective approval certificates.

Always observe the specifications and supplements in the certificates (see operating instructions).

Factory Mutual (FM)

IS

CL I, II, III, Div. 1, Grp. A-B-C-D-E-F-G

T6, T5, T4, Ta = 40 °C, 55 °C, 85 °C

901265 Entity, FISCO

NI

Class I, Div. 2, Grp. A-B-C-D

T6, T5, T4, Ta = 40 °C, 55 °C, 85 °C

S

CL II, III, Div. 2, Grp. E-F-G

T6, T5, T4, Ta = 40 °C, 55 °C, 85 °C

Enclosure type 4X

Canadian standard (CSA)

Intrinsically safe

Class I, Div. 1 Grp. A-B-C-D

Class II, Div. 1 Grp. E-F-G

CL III, Div. 1

Enclosure type 4X

ATEX / GOST Russia / GOST Ukraine

II 2G EEx ia IIC T6

Prototype test certificate:

TÜV 02 ATEX 1834 X

Type:

Intrinsically safe equipment

Device class:

II 2G (EEx ia IIC)

Temperature class:

T4, T5, T6

Permissible ambient temperature:

T4: $-40\text{ °C} \leq T_{amb} \leq 85\text{ °C}$

T5: $-40\text{ °C} \leq T_{amb} \leq 55\text{ °C}$

T6: $-40\text{ °C} \leq T_{amb} \leq 40\text{ °C}$

ATEX

II 3G EEx n A II T6

Prototype test certificate:

TÜV 02 ATEX 1943 X

Type:

Explosion-proof equipment
(Zone 2)

Device class:

II 3G (EEx n A II)

Temperature class:

T4, T5, T6

Permissible ambient temperature:

T4: $-40\text{ °C} \leq T_{amb} \leq 85\text{ °C}$

T5: $-40\text{ °C} \leq T_{amb} \leq 65\text{ °C}$

T6: $-40\text{ °C} \leq T_{amb} \leq 50\text{ °C}$

Signal circuit for FOUNDATION Fieldbus only for connecting a certified intrinsically safe circuit (e.g., FISCO power supply or barriers) with max. values acc. to:

	FISCO power supply ia/ib for Grp. IIB/IIC	FISCO power supply ia/ib for Grp. IIB/IIC	Barriers or power supply ia/ib for Grp. IIB/IIC
Voltage	Ui = 17.5 V	Ui = 17.5 V	Ui = 24 V
Current	li = 380 mA	li = 360 mA	li = 250 mA
Power	Pi = 5.32 W	Pi = 2.52 W	Pi = 1.2 W
Characteristic	rectangular	trapezoidal	linear

5.10 Options

Module for the emergency shutdown function

Supply voltage	24 V DC (20 ... 30 V DC) (galvanically isolated from input signal)
Safe position is activated when	voltage < 5 V
Explosion protection	see certificate (operating instructions)

A separate 24 V DC signal is normally applied to the emergency shutdown module, which connects through the signal from the microprocessor to the I/P module.

When the 24 V DC signal is interrupted, the pneumatic module executes the respective safety function, depending on the mechanical construction:

The positioner output Y1 is depressurized, and the valve is moved to the safe position. In case of a double-acting actuator the second output Y2 is additionally pressurized.

Important

The emergency shutdown module can only be used with pneumatics with the safe position "fail-safe".

The emergency shutdown module works independently of the mother board, i.e. all information from the final control element is available in the supervisory process control system at any time.

Mechanical position indicator

- Indicator disk
- Cover with transparent dome
- Symbol label
- Extension shaft

Digital position feedback with proximity switches

Two proximity switches for independent position signaling. Switching points adjustable between 0 ... 100 %

Current circuits acc. to DIN 19234 / NAMUR

Supply voltage	5 ... 11 V DC
Signal current < 1.0 mA	Switching state logical "0"
Signal current > 2.0 mA	Switching state logical "1"

(function dependent on software and electronics for actuator)

Direction of action (logical state)

Proximity switch	Position			
	< Lim. 1	> Lim. 1	< Lim. 2	> Lim. 2
SJ2-SN (NC)	0	1	1	0
SJ2-S1N (NO)	1	0	0	1

Digital position feedback with 24 V microswitches*

Two microswitches for independent position signaling. Switching points adjustable between 0 ... 100 %.

Voltage max. 24 V AC / DC
Load rating max. 2 A
Contact surface 10 µm Gold (AU)

Mechanical position indicator

Indicator disk in enclosure cover, linked with positioner feedback shaft.

*The "digital feedback" is activated directly from the axis of rotation for the variable pick-off and can only be used with the "mechanical position indicator".



Important

These options are also available for retrofitting by Service.

5.11 Accessories

Mounting material

- Attachment kit for linear actuators to DIN/IEC 534 / NAMUR
- Attachment kit for rotary actuators to VDI/VDE 3845
- Attachment kit for integral mounting to control valves
- Attachment kit for actuator-specific attachment upon request

Pressure gauge block

- Pressure gauges for supply and output pressure
- Pressure gauges with housing ø 28 mm
- Aluminum connection block in black
- Installation material for mounting on positioner

Filter regulator

All metal version in brass, varnished black, bronze filter element (40 µm) and condensate drain.

Max. pre-pressure 16 bar (232 psi), output adjustable to 1.4 ... 6 bar (20.31 ... 90 psi)

6 Electrical connections

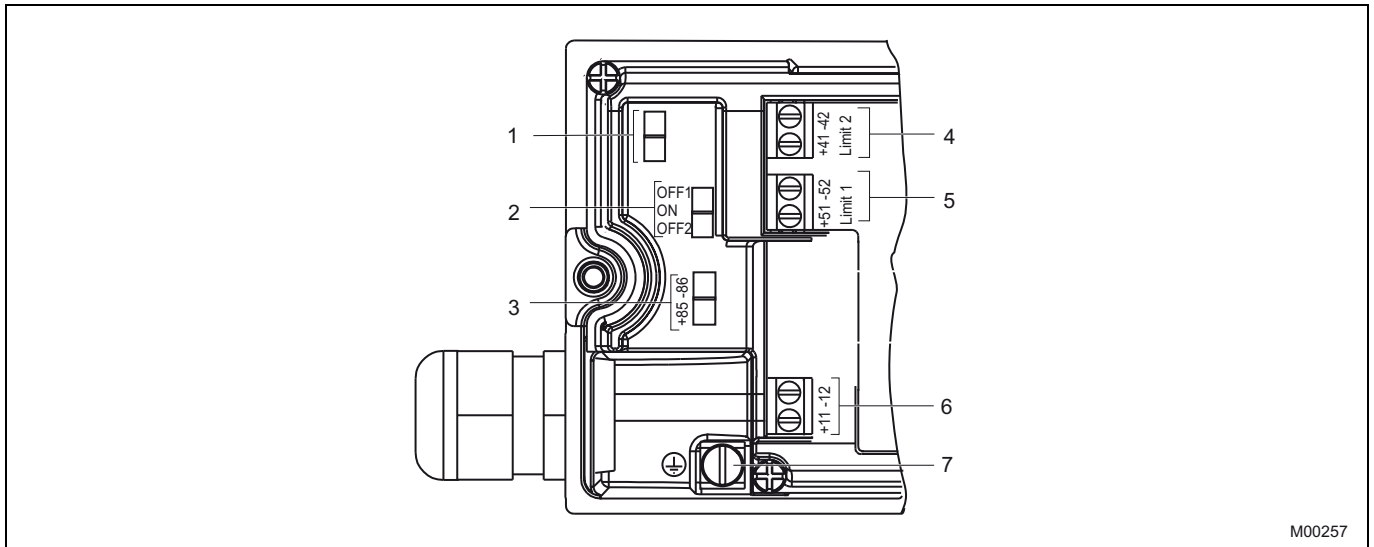

M00257

Fig. 6: Screw terminals, overview

- | | | | |
|---|--|---|-----------------|
| 1 | Not assigned | 5 | Same as 4 |
| 2 | Service switch for emergency shutdown module | 6 | Bus connector |
| 3 | Terminals of the shutdown module | 7 | Grounding screw |
| 4 | Digital position feedback, either proximity switches or 24 V microswitches | | |

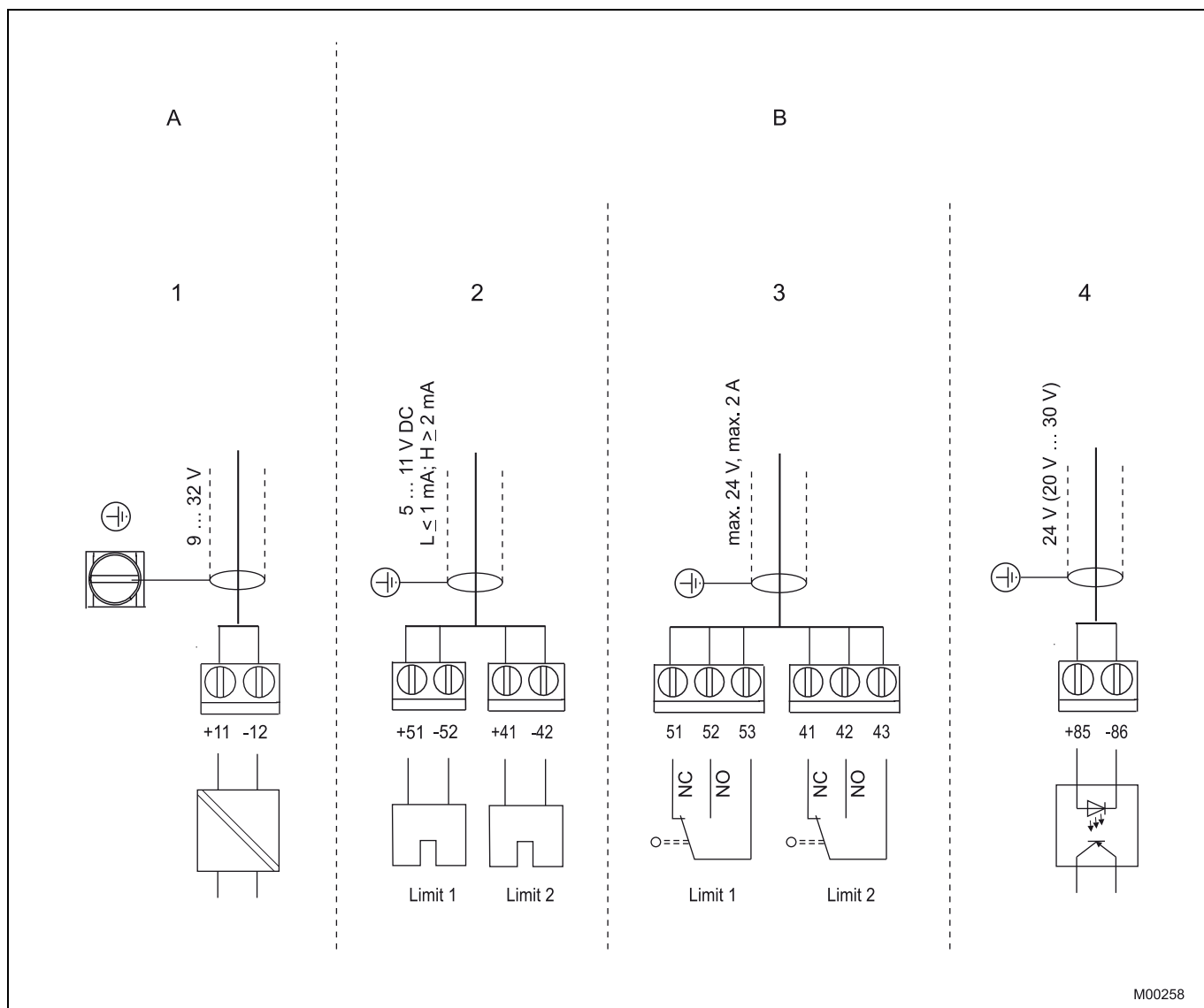

M00258

Fig. 7: Pin configuration

- A Basic model
- B Options

- 1 Fieldbus, bus feed
- 2 Proximity switches
- 3 Microswitches
- 4 Emergency shutdown module



Important

Keep cable shields as short as possible and connect on both sides.

7 Dimensions

All dimensions in mm (inch)

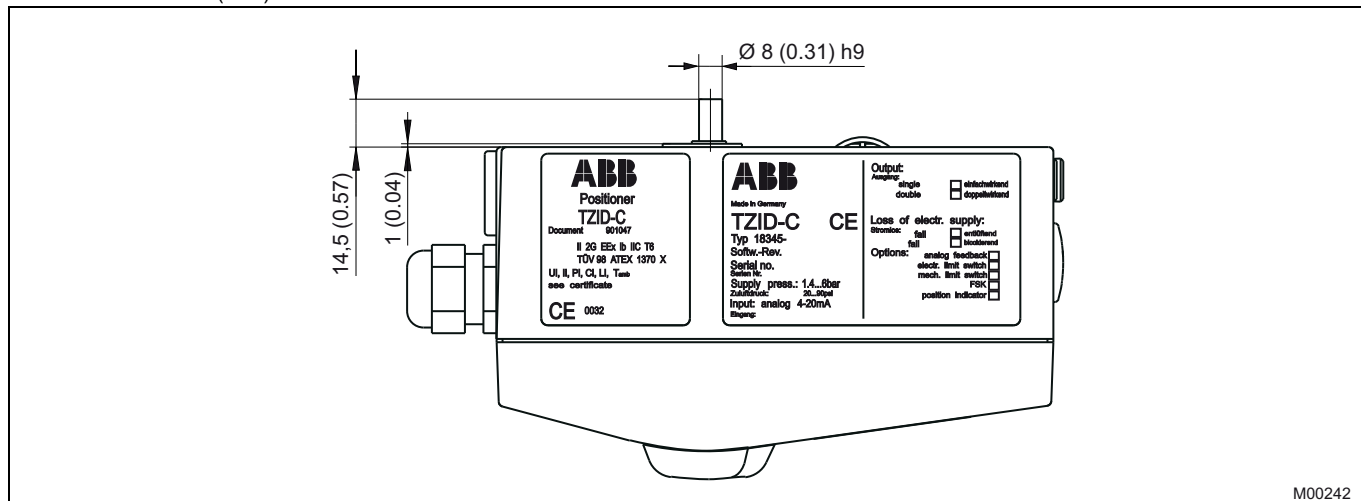

M00242

Fig. 8: Top view

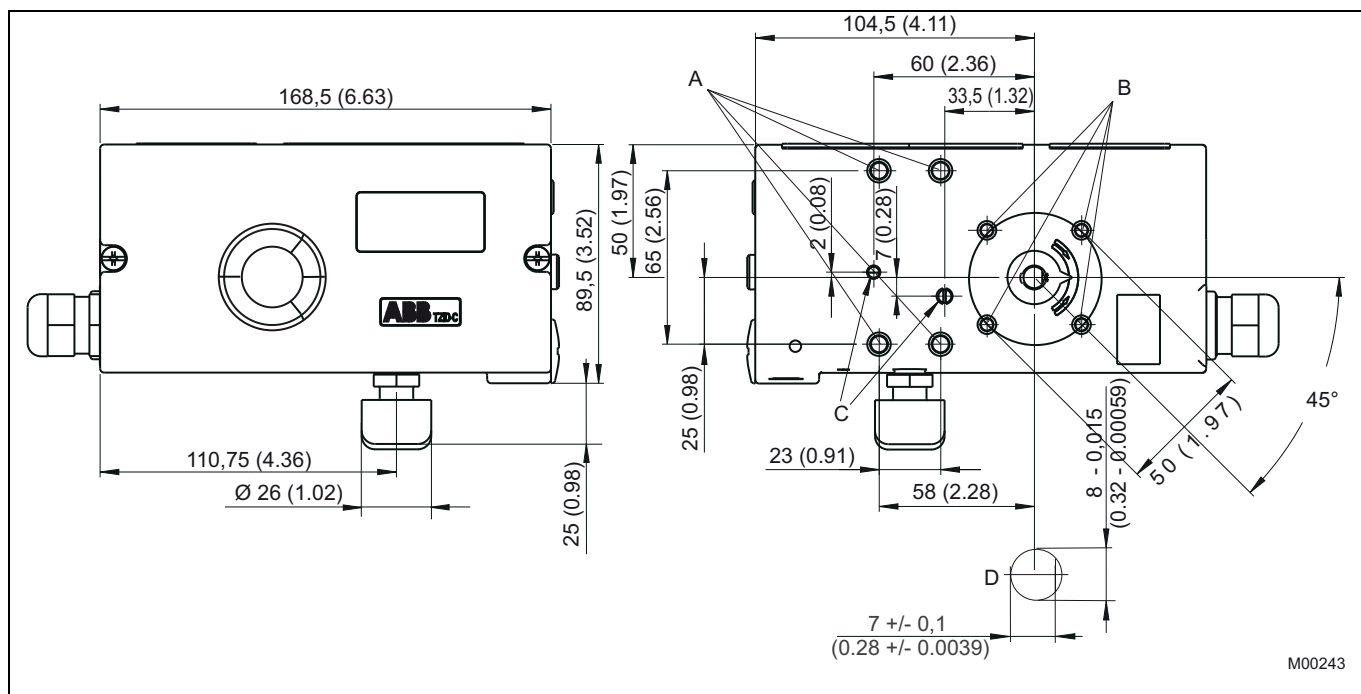

M00243

Fig. 9: Front and rear views

- A Tap hole M8 (10 mm low)
- B Tap hole M6 (8 mm low)

- C Tap hole M5 x 0.5 (air vents for direct mount)
- D Sensor shaft (larger than scale)

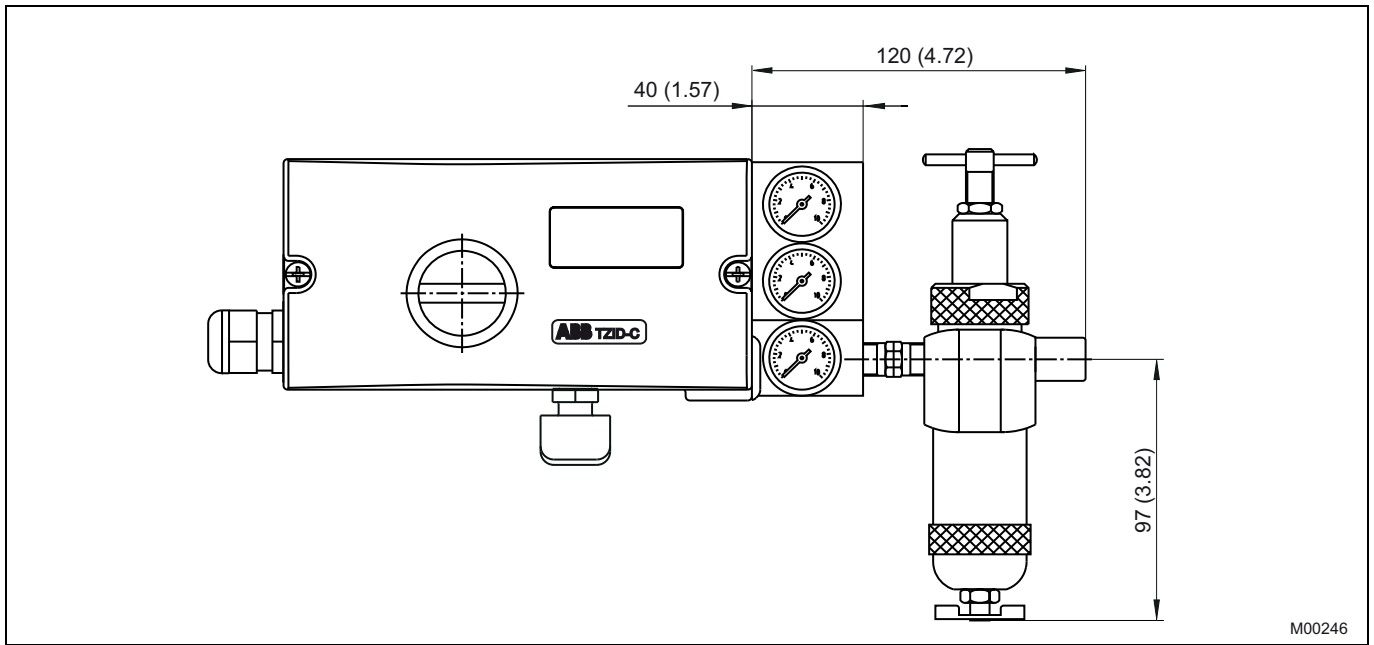

Fig. 12: Positioner TZIDC-120 with pressure gauge block and filter regulator

8 Ordering information

	Main Code											Add. Code	
	Variant digit No.	1 – 6	7	8	9	10	11	12	13	14	15		16
TZIDC-120 Electro-Pneumatic Positioner, for FOUNDATION Fieldbus, intelligent, configurable, with indicator and operator panel	V18347	X	X	X	X	X	X	X	X	X	X	X	XXX
Case / Mounting													XXX
Case made of aluminium, varnished, for mounting to linear actuators acc. DIN/IEC 534 / NAMUR or to rotary actuators acc. VDI/VDE 3845		1	0										
Case made of aluminium, varnished, with mechanical position indicator, for mounting to linear actuators acc. DIN/IEC 534 / NAMUR or to rotary actuators acc. VDI/VDE 3845		2	0										
Case made of aluminium, varnished, for integral mounting to control valves		3	0										
Case made of aluminium, varnished, with mechanical position indicator, for integral mounting to control valves		4	0										
Case made of aluminium, varnished, for mounting to rotary actuators acc. VDI/VDE 3845 with extended rotation angle up to 270°		5	0										
Case made of aluminium, varnished, with mechanical position indicator, for mounting to rotary actuators acc. VDI/VDE 3845 with extended rotation angle up to 270°		6	0										
Input / Communication Port													
FOUNDATION Fieldbus				4									
Explosion Protection													
Without						0							
ATEX EEx ia IIC T6						1							
FM / CSA						2							
ATEX EEx n A II T6						4							
IECEX Ex ia IIC T6						5							
IECEX Ex nA II T6						6							
GOST Russia Ex II 2 G EEx ia II C T6						A							
GOST Russia EEx n A II T6						C							
Output / Safe Position (in case of an electrical power failure)													
Single acting, fail safe						1							
Single acting, fail freeze						2							
Double acting, fail safe						4							
Double acting, fail freeze						5							
Connections													
Cable: Thread 1/2-14 NPT, air pipe: Thread 1/4-18 NPT							2						
Cable: Thread M20 x 1.5, air pipe: Thread 1/4-18 NPT							5						
Kabe Cable: Thread M20 x 1.5, air pipe: Thread G 1/4							6						
Option Module for Shutdown Function													
Without								0					
Plug-in module for shutdown function							1)	4					
Optional Mechanical Kit for Digital Position Feedback													
Without									0	0			
Mechanisc Mechanical kit for digital position feedback with proximity switches SJ2-SN (NC or logical 1)								2)	1	0			
Mechanical kit for digital position feedback with proximity switches SJ2-S1N (NO or logical 0)								3)	3	0			
Mechanical kit for digital position feedback with 24 V AC / DC microswitches (change-over contacts)								4)	5	0			

Continued on next page

- 1) Only for fail safe pneumatic
- 2) Only for model with mechanical position indicator
- 3) Only for model with mechanical position indicator and only for ambient temperature range -25 ... 85 °C
- 4) Not for explosion protected version and only for model with mechanical position indicator

Main Code												Add. Code
Variant digit No.	1 – 6	7	8	9	10	11	12	13	14	15	16	XXX
TZIDC-120 Electro-Pneumatic Positioner, for FOUNDATION Fieldbus, intelligent, configurable, with indicator and operator panel		V18347	X	X	X	X	X	X	X	X	X	XXX
Design (Varnish / Coding)												
Standard											1	
Special version for Chemical Industries											5) E	
Protection Class IP 66 / NEMA 4X											P	
Certificate of Compliance												
Certificate of compliance with the order acc. EN 10204-2.1 (DIN 50049-2.1)											CF1	
Certificate of compliance with the order acc. EN 10204-2.1 (DIN 50049-2.1) with item description											CF2	
Test report acc. EN 10204-2.2 (DIN 50049-2.2)											CF3	
Inspection Certificate												
Inspection certificate 3.1 acc. EN 10204											CBA	
Device Identification Label												
Stainless steel 11.5 x 60 mm (0.45 x 2.36 in.)											MK1	
Sticker 11 x 25 mm (0.43 x 0.98 in.)											MK3	

5) Details on request

8.1 Accessories

Accessories	Order number
TZIDC Mounting bracket	
TZIDC Mounting bracket for rotary actuators (mounting to VDI / VDE 3845), dimension A/B = 80/20 mm	319603
TZIDC Mounting bracket for rotary actuators (mounting to VDI / VDE 3845), dimension A/B = 80/30 mm	319604
TZIDC Mounting bracket for rotary actuators (mounting to VDI / VDE 3845), dimension A/B = 130/30 mm	319605
TZIDC Mounting bracket for rotary actuators (mounting to VDI / VDE 3845), dimension A/B = 130/50 mm	319606
TZIDC Attachment kit for linear actuators	
TZIDC Attachment kit for linear actuators, stroke 10 ... 35 mm	7959125
TZIDC Attachment kit for linear actuators, stroke 20 ... 100 mm	7959126
TZIDC Lever	
TZIDC Lever 30 mm	7959151
TZIDC Lever 100 mm	7959152
TZIDC Adapter	
TZIDC Adapter (shaft coupler) for rotary actuators (mounting to VDI / VDE 3845)	7959110

Continued on next page

Accessories	Order number
TZIDC Pressure gauge block	
TZIDC Pressure gauge block, for single acting TZIDC, 0 ... 6 bar (0 ... 90 psi), G 1/4 connections	7959111
TZIDC Pressure gauge block, for single acting TZIDC, 0 ... 10 bar (0 ... 140 psi), G 1/4 connections	7959112
TZIDC Pressure gauge block, 0.6 MPa, single acting, G 1/4 connection	7959364
TZIDC Pressure gauge block, 0.6 MPa, single acting, Rc 1/4 connection	7959358
TZIDC Pressure gauge block, 0.6 MPa, single acting, NPT 1/4 connection	7959360
TZIDC Pressure gauge block, for single acting TZIDC, 0 ... 6 bar (0 ... 90 psi), 1/4-18 NPT connections	7959113
TZIDC Pressure gauge block, for single acting TZIDC, 0 ... 10 bar (0 ... 140 psi), 1/4-18 NPT connections	7959114
TZIDC Pressure gauge block, for double acting TZIDC, 0 ... 6 bar (0 ... 90 psi), G 1/4 connections	7959115
TZIDC Pressure gauge block, for double acting TZIDC, 0 ... 10 bar (0 ... 140 psi), G 1/4 connections	7959116
TZIDC Pressure gauge block, 0.6 MPa, double acting, G 1/4 connection	7959365
TZIDC Pressure gauge block, 0.6 MPa, double acting, Rc 1/4 connection	7959359
TZIDC Pressure gauge block, 0.6 MPa, double acting, NPT 1/4 connection	7959361
TZIDC Pressure gauge block, for double acting TZIDC, 0 ... 6 bar (0 ... 90 psi), 1/4-18 NPT connections	7959117
TZIDC Pressure gauge block, for double acting TZIDC, 0 ... 10 bar (0 ... 140 psi), 1/4-18 NPT connections	7959118
TZIDC Filter regulator	
TZIDC Filter regulator, brass, connections thread G 1/4, incl. material for mounting to pressure gauge block	7959119
TZIDC Filter regulator, brass, connections thread 1/4-18 NPT, incl. material for mounting to pressure gauge block	7959120
TZIDC Attachment kit	
TZIDC Attachment kit for Badger Meter ATC 754/755	7959123
TZIDC Attachment kit for Fisher 1051-30, 1052-30	7959214
TZIDC Attachment kit for Fisher 1061 size 130	7959206
TZIDC Attachment kit for Fisher 471	7959195
TZIDC Attachment kit for Fisher 585 C	7959250
TZIDC Attachment kit for Fisher 657 / 667 Size 10 ... 30 mm	7959177
TZIDC Attachment kit for GEMÜ 690/25 and 50	7959103
TZIDC Attachment kit for Gulde DK	7959161
TZIDC Attachment kit for Keystone 79U/E-002(S) ... 79U/E-181(S)	7959147
TZIDC Mounting kit Koso short lever	7959362
TZIDC Mounting kit Koso long lever	7959363
TZIDC Attachment kit for Masoneilan CAMFLEX II, VARIMAX, MINITORK II	7959144
TZIDC Attachment kit for Masoneilan VariPak 28000 series	7959163
TZIDC Attachment kit for MaxFlo MaxFlo	7959140
TZIDC Attachment kit for NAF 791290	7959207
TZIDC Attachment kit for NAMUR stroke 100 ... 170 mm	7959339
TZIDC Attachment kit for NELES BC6-20, B1C6-20, BJ8-20, B1J8-20	7959146
TZIDC Attachment kit for Valves Nuovo Pignone, lever for linear stroke, length 150 ... 250 mm	7959210
TZIDC Attachment kit for Valves Nuovo Pignone, pressure gauge block with 2 manometers, material stainless steel	7959181
TZIDC Attachment kit for Samson 241, 271, 3271	7959145
TZIDC Attachment kit for Samson 3277	7959136
TZIDC Attachment kit for Schubert&Salzer GS 8020 / 8021 / 8023	7959200
TZIDC Attachment kit for SED SED stroke 100 mm	7959141

Contact us

ABB Ltd.

Process Automation

Salterbeck Trading Estate
Workington, Cumbria
CA14 5DS
UK

Phone: +44 (0)1946 830 611

Fax: +44 (0)1946 832 661

ABB Inc.

Process Automation

125 E. County Line Road
Warminster, PA 18974
USA

Phone: +1 215 674 6000

Fax: +1 215 674 7183

ABB Automation Products GmbH

Process Automation

Schillerstr. 72
32425 Minden
Germany

Phone: +49 551 905-534

Fax: +49 551 905-555

www.abb.com

Note

We reserve the right to make technical changes or modify the contents of this document without prior notice. With regard to purchase orders, the agreed particulars shall prevail. ABB does not accept any responsibility whatsoever for potential errors or possible lack of information in this document.

We reserve all rights in this document and in the subject matter and illustrations contained therein. Any reproduction, disclosure to third parties or utilization of its contents - in whole or in parts - is forbidden without prior written consent of ABB.

Copyright© 2010 ABB

All rights reserved