

Programmable Controller

FP-XH Series

User Manual

Basics

- Applicable Models

- FP-XH C14R/C14T/C30R/C30T/C40R/C40T/
C60R/C60T

SAFETY PRECAUTIONS

To prevent accidents or personal injuries, please be sure to comply with the following items.
Prior to installation, operation, maintenance and check, please read this manual carefully for proper use.
Before using, please fully understand the knowledge related to the equipment, safety precautions and all other precautions.

Safety precautions are divided into two levels in this manual: Warning and Caution.



Warning Incorrect operation may lead to death or serious injury.

- Take appropriate safety measures to the external circuit of the product to ensure the security of the whole system in case of abnormalities caused by product failure or external factors.
- Do not use this product in areas with inflammable gases.
Otherwise it may lead to an explosion.
- Do not put this product into a fire.
Otherwise it could cause damage to the battery or other electronic parts.
- Do not impact, charge or heat the lithium battery, and do not put it into a fire.
Otherwise it may lead to fire or damage.



Caution Incorrect operation may lead to injury or material loss.

- To prevent the excessive exothermic heat or smoke generation of the product, a certain margin is required for guaranteed characteristics and performance ratings of relative products.
- Do not decompose or transform it.
Otherwise it will lead to the excessive exothermic heat or smoke generation of the product.
- Do not touch terminal blocks during power-on.
Otherwise it may result in an electric shock.
- Set an emergency stop and interlock circuit in the external devices.
- Connect wires and connectors reliably.
Otherwise it may lead to the excessive exothermic heat or smoke generation of the product.
- Ground the protective earth (PE) terminal (Class D grounding).
Otherwise it may result in an electric shock.
- There shall be no foreign matters such as liquids, flammable materials and metals inside the product.
Otherwise it will lead to the excessive exothermic heat or smoke generation of the product.
- Do not carry out construction (wiring, removal, etc.) during power-on.
Otherwise it may result in an electric shock.

Description on Copyright and Trademarks

- This manual is copyrighted by Panasonic Shenshi (Suzhou) Co., Ltd. all.
- Unauthorized reproduction of this manual is strictly prohibited.
- Windows is a registered trademark of Microsoft Corporation in the U.S. and other countries.
- Ethernet is a registered trademark of Fuji Xerox Co., Ltd. and Xerox Corporation.
- Other company and product names are trademarks or registered trademarks of their respective companies.

Foreword

Thanks a lot for purchasing Panasonic products! Before using, please carefully read the Construction Manual and User Manual to fully understand relevant contents. Make sure to use this product properly.

Type of Manual

- FP-XH series user manual types are as follows. Please use it according to the used unit and its usage.
- Download the manual from the company's home page
http://industrial.panasonic.com/ac/c/dl_center/manual/

Unit Name or Usage	Manual Name	Manual Symbol
FP-XH Control Unit	FP-XH User Manual (Basic Section)	WUMC-FPXHBAS
	FP Series Programming Manual	ARCT1F353C
Position Control/PWM Output/ High-speed Counter Function	FP-XH User Manual (Position Control/PWM Output/High-speed Counter Section)	WUMC-FPXHPOS
Communication Function	FP-XH User Manual (Communication Section)	WUMC-FPXHCOM
FP-X Expansion (Communication) Card		
FP-X Expansion Unit	FP-X Series User Manual	ARCT1F409C
FP-X Function Card		

Compatibility with old FP-X / FP-X0 series

Although the FP-XH series is highly compatible with the old FP-X / FP-X0 control units, you may still need to keep in mind the following.

■ Hardware Compatibility

- FP-X expansion unit can be used with FP-X0 expansion unit.
- You can also use FP-X expansion card (communication card) and FP-X expansion card (function card). In the FP-XH control unit, there are less installation location limitations.
- The wiring of transistor type control units is different. No need for an external power supply (24 VDC) for output circuit drive to supply power.
- Backup battery types are different. Batteries for FP-XH series are required.
- The programming port uses USB 2.0 (miniB type) to connect to the computer.

■ Software compatibility

- The position control function is greatly strengthened. The data sheet setting mode is added to simplify setup and procedure. In addition, the position control mode and the origin return mode are added.
- When using programs (program, comment, system register) created by old model FP-X, you must use the model conversion function of the tool software to convert it to programs for FP-XH (program, comment, system register).
- Supports all instructions for old model FP-X.

Command	Division	Differences Between Main Specifications
SYS1	Communication condition setting	Expand the range of port number and communication speed that can be specified.
F12 (ICRD)	F-ROM read	Expand the range of block number to be specified when executing instructions.
P13 (PICWT)	F-ROM write	
F145 (SEND)	Data transmission instruction	Expand the range of COM port number to be specified when the MEWTOCOL or MODBUS master station is transmitted.
F146 (RECV)	Data transmission instruction	
F172 (PLSH)	Pulse output (JOG operation) instruction	Characteristics of acceleration and deceleration intervals are different.
F173 (PWMH)	PWM output instruction	Simplifies parameter setting.
F380 (POST)	Position control data sheet start up	Added to the position control function (data sheet setting mode).
F381 (JOGST)	JOG operation start	
F382 (ORGST)	Origin return start	
F383 (MPOST)	Start position control and data sheet at the same time	
F384 (PTBLR)	Read position control parameters	
F385 (PTBLW)	Write position control parameters	

Contents

1. System Structure 1-1

- 1.1 Unit List..... 1-2
 - 1.1.1 FP-XH Control Unit..... 1-2
 - 1.1.2 FP-X / FP-X0 Expansion Unit..... 1-2
 - 1.1.3 FP-X Expansion FP0 Adapter 1-3
 - 1.1.4 FP-X Expansion Card (Communication Card) 1-3
 - 1.1.5 FP-X Expansion Card (Function Card) 1-3
- 1.2 Unit Type Summary 1-4
 - 1.2.1 FP-XH Control Unit..... 1-4
 - 1.2.2 FP-X Expansion Unit..... 1-4
 - 1.2.3 FP-X0 Expansion Unit..... 1-5
 - 1.2.4 FP-X Expansion FP0 Adapter 1-5
 - 1.2.5 FP-X Expansion Card (Communication Card) 1-5
 - 1.2.6 FP-X Expansion Card (Function Card) 1-6
 - 1.2.7 Options 1-6
 - 1.2.8 Repair Parts 1-6
- 1.3 Unit Combination Restrictions 1-7
 - 1.3.1 Use Restrictions of FP-X Expansion Units..... 1-7
 - 1.3.2 Use Restrictions of FP-X Expansion Adapter 1-9
 - 1.3.3 Limitations on Expansion Card Combination 1-10
 - 1.3.4 Use limitations on Communication Function..... 1-12
 - 1.3.5 Limitations on Function Combination 1-13
- 1.4 Programming Tools..... 1-14
 - 1.4.1 Software Environment and Applicable Cables..... 1-14
 - 1.4.2 Corresponding Version of the Software 1-14

2. Control Unit Specifications 2-1

- 2.1 Name and Function of Each Part.....2-2
 - 2.1.1 Name and Function of Each Part2-2
 - 2.1.2 Action Display LED Unit Specifications.....2-4
 - 2.1.3 COM0 Port Specifications2-5
- 2.2 Power Specifications2-6
 - 2.2.1 AC Power Supply Type2-6
 - 2.2.2 AC Power Supply Type: Universal Power Supply for Input Circuit2-6
 - 2.2.3 DC Power Supply Type2-7
- 2.3 Input and Output Specifications (Relay Output Type)2-8
 - 2.3.1 Input Specifications2-8
 - 2.3.2 Output Specifications2-9
- 2.4 Input and Output Specifications (Transistor Output Type).....2-10
 - 2.4.1 Input Specifications2-10
 - 2.4.2 Output Specifications2-11
- 2.5 Terminal arrangement2-12
 - 2.5.1 Relay Output AC Power Supply Type2-12
 - 2.5.2 Relay Output DC Power Supply Type.....2-14
 - 2.5.3 Transistor Output AC Power Supply Type2-16
 - 2.5.4 Transistor Output DC Power Supply Type2-18

3. I/O Number Assignment 3-1

- 3.1 Basic I/O Assignment3-2
 - 3.1.1 Counting Method of I/O Numbers3-2
 - 3.1.2 I/O Number Assignment Method.....3-2
- 3.2 List of I/O Numbers for Units3-4
 - 3.2.1 FP-XH Control Unit.....3-4
 - 3.2.2 FP-X Expansion Unit3-4
 - 3.2.3 FP-X0 Expansion Unit.....3-4

3.2.4	FP-X Function Card.....	3-5
3.3	Assignment of FP0 Expansion Units	3-6
3.3.1	I/O Number Assignment Method.....	3-6
3.3.2	Types and I/O Numbers of FP0R Expansion Units	3-7
3.3.3	Types and I/O Numbers of FP0 Expansion Unit.....	3-8
4.	Installation and Wiring.....	4-1
4.1	Installation.....	4-2
4.1.1	Installation Environment and Space.....	4-2
4.2	Backup Battery Installation.....	4-4
4.2.1	Backup Battery Installation.....	4-4
4.3	Expansion Card Installation.....	4-5
4.3.1	Precautions for Installing Expansion Cards	4-5
4.3.2	Communications Card Installation	4-5
4.3.3	Function Card Installation	4-6
4.4	Connecting FP-X expansion unit.....	4-7
4.4.1	Setup of Terminal Setting Switches	4-7
4.4.2	Confirmation of FP-X Expansion Cables	4-7
4.4.3	Connecting FP-X expansion unit.....	4-8
4.5	Connecting FP0 Expansion Unit	4-9
4.5.1	Connecting FP0 Expansion Unit	4-9
4.5.2	Connecting FP-X Expansion FP0 Adapter.....	4-10
4.6	Installation.....	4-11
4.6.1	Installation and Removal for DIN Rail	4-11
4.6.2	Mounting with Screws	4-12
4.7	Power Wiring	4-13
4.7.1	General Precautions	4-13
4.7.2	Grounding.....	4-13
4.7.3	Power Supply of Control Unit / Expansion Unit.....	4-14
4.7.4	Power Supply of FP-X Expansion FP0 Adapter / FP0 Expansion Unit.....	4-16

- 4.8 Input and Output Wiring.....4-18
 - 4.8.1 Common Considerations for Input and Output4-18
 - 4.8.2 Universal Power for Input and Output (Control Unit and Expansion Unit E30).....4-18
 - 4.8.3 Wiring of the Input Side4-19
 - 4.8.4 Wiring of the Output Side4-21
- 4.9 Terminal Block Wiring.....4-22
 - 4.9.1 Applicable wires4-22
 - 4.9.2 Terminal Block Cover4-22
 - 4.9.3 Removal and Installation of the Terminal Block (C30 / C40 / C60).....4-23
- 4.10 Safety Measures4-24
 - 4.10.1 Safety Measures4-24
 - 4.10.2 Temporal Outage4-25
 - 4.10.3 Watchdog Timer4-25

5. Steps Before Running 5-1

- 5.1 Before Turning on the Power.....5-2
 - 5.1.1 Check Items5-2
 - 5.1.2 Steps Before Running5-3
- 5.2 Offline Editing of the Program.....5-4
 - 5.2.1 Program Elements.....5-4
 - 5.2.2 Settings of the System Register.....5-4
 - 5.2.3 Setting of Position Control Parameters5-5
- 5.3 Program Download and Run5-6
 - 5.3.1 Before Turning on the Power5-6
 - 5.3.2 Overall Program Check.....5-7
 - 5.3.3 Program Downloading and Mode Switching5-7
 - 5.3.4 Program Check5-10
- 5.4 Online Editing5-11
 - 5.4.1 Online Editing Summary.....5-11

5.4.2	Online Editing of the Program	5-11
5.4.3	Online Editing of the System Register	5-13
5.4.4	Download Function in RUN Mode	5-14

6. Memory / Main Memory Card..... 6-1

6.1	Storage Backup	6-2
6.1.1	Program Memory Backup	6-2
6.1.2	Operational Memory Backup.....	6-2
6.1.3	Operational Memory Backup (When Battery Installed).....	6-3
6.1.4	Alarm Battery Error / Setting of the Hold Area	6-4
6.2	RAM / ROM Transfer Function	6-5
6.2.1	Function Outline	6-5
6.2.2	Operations Using the Tool Software	6-5
6.3	Functions of the Main Memory Card	6-6
6.3.1	Function Outline	6-6
6.3.2	Setting of the Main Memory Unit.....	6-6
6.4	Main memory function.....	6-7
6.4.1	Function Outline	6-7
6.4.2	Before Turning on the Power	6-8
6.4.3	Transferring Data to the Main Memory Card	6-9
6.4.4	Transfer from the Main Memory Card to the Unit Controller.....	6-11
6.4.5	Use between the Main Memory Card Models.....	6-12
6.5	Calendar clock	6-13
6.5.1	Function Outline	6-13
6.5.2	Calendar Clock Setting	6-13
6.5.3	Calendar Clock Application Examples	6-14

7. Security Functions..... 7-1

7.1	Password Protection Function.....	7-2
7.1.1	Function Outline	7-2

7.1.2	Tool software setting	7-2
7.2	Program Upload Prohibited Function	7-8
7.2.1	Function Outline	7-8
7.2.2	Tool software setting	7-9
7.3	Security Function Applicability List.....	7-10
7.3.1	Control Unit Controller.....	7-10
8.	Other Functions	8-1
8.1	Analog potentiometer	8-2
8.1.1	Function Outline	8-2
8.1.2	Analog Potentiometer Application Examples	8-2
8.2	Input Time Constant Setting Function.....	8-3
8.2.1	Function Outline	8-3
9.	Troubleshooting	9-1
9.1	Self-diagnosis function	9-2
9.1.1	Status display LED of the control unit	9-2
9.1.2	Status Display LED of the FP-X Expansion FP0 Adapter.....	9-3
9.1.3	Operation mode in case of exception.....	9-3
9.2	Troubleshooting Exceptions	9-4
9.2.1	ERROR LED blinking	9-4
9.2.2	When Not Switched to RUN Mode	9-6
9.2.3	When ERR.LED Lights Up	9-6
9.2.4	If all LEDs are not lit	9-7
9.2.5	When Protection Error Message Shows	9-7
9.2.6	When the Output is Not Normal	9-8
9.2.7	If Expansion Units Not Operated.....	9-9
9.2.8	If a Communication Error Occurs (RS-232C).....	9-10
9.2.9	If a Communication Error Occurs (RS-422)	9-10
9.2.10	If a Communication Error Occurs (RS-485)	9-11

9.2.11 If a Communication Error Occurs (Ethernet).....9-12

10. Maintenance and Inspection..... 10-1

10.1 Precautions for Using Backup Battery 10-2
 10.1.1 Backup Battery Replacement.....10-2
 10.1.2 Backup Battery Lifetime and Replacement Time.....10-3
 10.2 Inspection 10-4

11. Specification 11-1

11.1 Control Unit Specifications 11-2
 11.1.1 General Specification 11-2
 11.1.2 Performance specification..... 11-4
 11.1.3 Communication Specifications 11-6
 11.2 Operational Storage Area 11-7
 11.3 System Register List 11-8
 11.4 Special Relay List 11-19
 11.5 Special Data Register List..... 11-32
 11.6 Error Code List..... 11-49
 11.6.1 Syntax Check Error List 11-49
 11.6.2 Self-diagnostic Error List 11-50
 11.6.3 MEWTOCOL-COM Communication Error Code List..... 11-52
 11.7 Dimensions 11-53
 11.7.1 Dimensions..... 11-53
 11.7.2 Installation Dimensions 11-54

1

System Structure

1.1 Unit List

1.1.1 FP-XH Control Unit

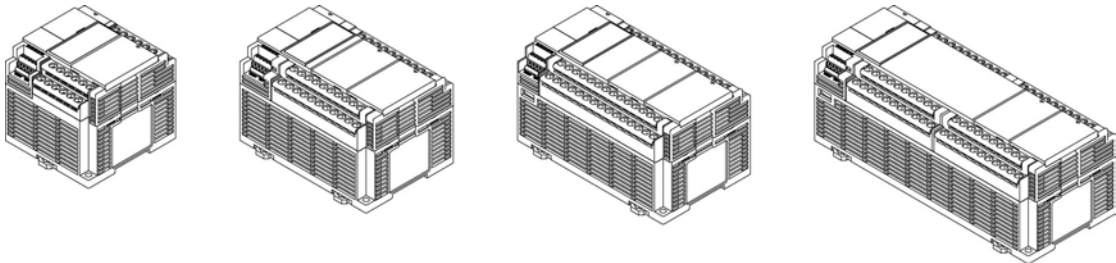

Divided into the following types according to points, power supply and output type.

Points	14 points / 30 points / 40 points / 60 points
Power supply	100-240 VAC or 24 VDC
Output	Relay or transistor (NPN output)

1.1.2 FP-X / FP-X0 Expansion Unit

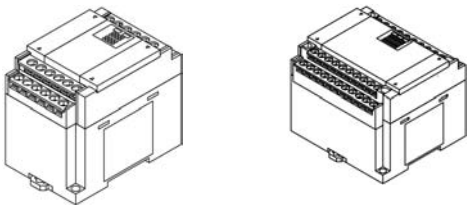

Divided into the following types according to points, power supply and output type. Can be used with the old models FP-X, FP-X0.

■ FP-X Expansion Unit

Points	14 points (for output) / 16 points (for input) / 16 points	30 points
Power supply	No power supply	100-240 VAC or 24 VDC
Output	Relay or transistor (NPN output or PNP output)	

■ FP-X0 Expansion Unit

Points	24 points	40 points
Power supply	No power supply	24 VDC
Output	Relay or transistor (NPN output or PNP output)	

1.1.3 FP-X Expansion FP0 Adapter

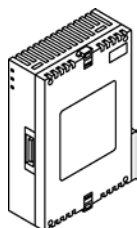

Interface adapters enabling connection with FP0 series expansion unit / high function unit.

1.1.4 FP-X Expansion Card (Communication Card)

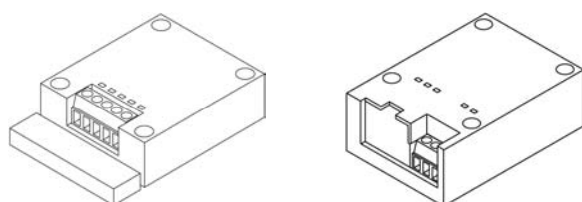

Divided into the following types according to the type of communication interface and the number of channels.

Communication pattern	RS-232C (5-wire) × 1ch
	RS-232C (3-wire) × 2ch
	RS-485 / RS-422 × 1ch
	RS-485 × 1ch + RS-232C (3-wire) × 1ch
	RS-485 × 2ch
	Ethernet × 1ch + RS-232C (3-wire) × 1ch

1.1.5 FP-X Expansion Card (Function Card)

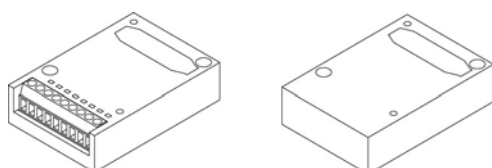

Divided into the following types according to the output type and function.

Analog input and output	Analog input × 2ch Analog output × 2ch Analog input × 2ch + analog output × 1ch
Digital input and output	Input 8 points, transistor output 8 points Input 4 points + transistor output 3 points
Pulse input and output	High-speed counter × 2ch + pulse output × 1ch
Main memory	Main memory + real-time clock

1.2 Unit Type Summary

1.2.1 FP-XH Control Unit

Product Name	Specification		Order Number
	Input / Output Specifications	Power supply	
FP-XH C14R control unit	DC input 8 points, relay output 6 points	100-240 VAC	AFPXHC14R
		24 VDC	AFPXHC14RD
FP-XH C14T control unit	DC input 8 points, transistor (NPN) output 6 points	100-240 VAC	AFPXHC14T
		24 VDC	AFPXHC14TD
FP-XH C30R control unit	DC input 16 points, relay output 14 points	100-240 VAC	AFPXHC30R
		24 VDC	AFPXHC30RD
FP-XH C30T control unit	DC input 16 points, transistor (NPN) output 14 points	100-240 VAC	AFPXHC30T
		24 VDC	AFPXHC30TD
FP-XH C40R control unit	DC input 24 points, relay output 16 points	100-240 VAC	AFPXHC40R
		24 VDC	AFPXHC40RD
FP-XH C40T control unit	DC input 24 points, transistor (NPN) output 16 points	100-240 VAC	AFPXHC40T
		24 VDC	AFPXHC40TD
FP-XH C60R control unit	DC input 32 points, relay output 28 points	100-240 VAC	AFPXHC60R
		24 VDC	AFPXHC60RD
FP-XH C60T control unit	DC input 32 points, transistor (NPN) output 28 points	100-240 VAC	AFPXHC60T
		24 VDC	AFPXHC60TD

1.2.2 FP-X Expansion Unit

Product Name	Specification		Order Number
	Input / Output Specifications	Power supply	
FP-X E16 expansion I/O unit	DC input 8 points, relay output 8 points	-	AFPX-E16R
	DC input 8 points, transistor output (NPN) 8 points	-	AFPX-E16T
	DC input 8 points, transistor output (PNP) 8 points	-	AFPX-E16P
FP-X E30 expansion I/O unit	DC input 16 points, relay output 14 points	100-240 VAC	AFPX-E30R
		24 VDC	AFPX-E30RD
	DC input 16 points, transistor output (NPN) 14 points	100-240 VAC	AFPX-E30T
		24 VDC	AFPX-E30TD
DC input 16 points, transistor output (PNP) 14 points	100-240 VAC	AFPX-E30P	
	24 VDC	AFPX-E30PD	
FP-X E16 expansion input unit	DC input 16 points	-	AFPX-E16X
FP-X E14R expansion output unit	Relay output 14 points	-	AFPX-E14YR

(Note) Comes with expansion cables (8 cm type).

1.2.3 FP-X0 Expansion Unit

Product Name	Specification		Order Number
	Input / Output Specifications	Power supply	
FP-X0 E24 expansion I/O unit	DC input 16 points, relay output 8 points	-	AFPX0E24R
	DC input 16 points, transistor output (NPN) 8 points	-	AFPX0E24T
	DC input 16 points, transistor output (PNP) 8 points	-	AFPX0E24P
FP-X0 E40 expansion I/O unit	DC input 24 points, relay output 16 points	24 VDC	AFPX0E40RD
	DC input 24 points, transistor output (NPN) 16 points	24 VDC	AFPX0E40TD
	DC input 24 points, transistor output (PNP) 16 points	24 VDC	AFPX0E40PD

(Note) Comes with expansion cables (8 cm type).

1.2.4 FP-X Expansion FP0 Adapter

Name	Specification	Order Number
FP-X Expansion FP0 Adapter	Used to connect with the FP0 expansion unit	AFPX-EFP0

(Note) Comes with expansion cables (8 cm type).

1.2.5 FP-X Expansion Card (Communication Card)

Name	Specification	Order Number
FP-X communication card	RS-232C 5-wire × 1 channel	AFPX-COM1
	RS-232C 3-wire × 2 channel	AFPX-COM2
	RS-485 / RS-422 (insulated) × 1 channel	AFPX-COM3
	RS-485 (insulated) × 1 channel + RS-232C 3-wire × 1 channel	AFPX-COM4
	RS-485 (insulated) × 2 channels (non-insulated between channels)	AFPX-COM6
	Ethernet port + RS-232C 3-wire × 1 channel	AFPX-COM5



1.2.6 FP-X Expansion Card (Function Card)

Name		Specification	Order Number
Analog input and output	FP-X analog input card	Analog input (non-isolated) × 2 channels	AFPX-AD2
	FP-X analog output card	Analog output (insulated) × 2 channels (insulated between channels)	AFPX-DA2
	FP-X analog I/O card	Analog input (insulated) × 2 channels (non-insulated between channels) + analog output (insulated) × 1 channel	AFPX-A21
	FP-X thermocouple card	Thermocouple input (insulated) × 2 channels (insulated between channels)	AFPX-TC2
	FP-X temperature measuring resistor card	Temperature measuring resistor input (insulated) × 2 channels (insulated between channels)	AFPX-RTD2
Digit input and output	FP-X input card	8-point DC input	AFPX-IN8
	FP-X output card	8-point transistor output (NPN)	AFPX-TR8
	FP-X output card	6-point transistor output (PNP)	AFPX-TR6P
	FP-X input and output card	4-point DC input + 3-point transistor output (NPN)	AFPX-IN4T3
FP-X pulse input and output card		High-speed counter 2ch + pulse output 1ch	AFPX-PLS
FP-X main memory card		Main memory + real-time clock	AFPX-MRTC

1.2.7 Options

Name	Specification	Order Number
FP-XH backup battery	Required when expanding operational memory keeping area and using the calendar clock function.	AFPXHBATT

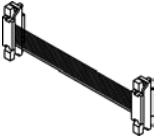
1.2.8 Repair Parts

	Name	Specification	Order Number
	FP-X expansion cable (note)	8 cm	AFPX-EC08
		30 cm	AFPX-EC30
		80 cm	AFPX-EC80
	FP0 power cable	For expansion FP0 adapters, 1 m long	AFP0581

(Note 1): The FP0 expansion unit and high-function unit include 8 cm expansion cables. Please limit the total length to less than 160 cm when using.

(Note 2): when using long expansion cables, I/O checking error may occur due to noises and other effects. In this case, it is recommended to take measures such as using ferrite cores.

1.3 Unit Combination Restrictions

1.3.1 Use Restrictions of FP-X Expansion Units

■ Expansion Number and Order Limitations (1)

- Connect up to 8 expansion units.

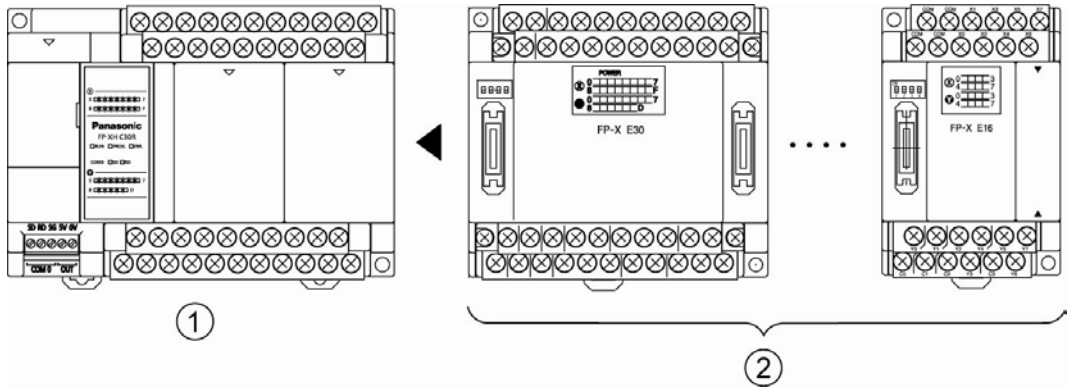

①	FP-XH Control Unit	②	FP-X / FP-X0 Expansion Unit
---	--------------------	---	-----------------------------

■ Maximum Control I/O Points

Type of Control Unit	I/O Points for Single Control Unit	I/O Points for FP-X E30 Expansion	I/O Points for FP-X0 E40 Expansion
FP-XH C14 control unit	14 points	Maximum 254 points	Maximum 334 points
FP-XH C30 control unit	30 points	Maximum 270 points	Maximum 350 points
FP-XH C40 control unit	40 points	Maximum 280 points	Maximum 360 points
FP-XH C60 control unit	60 points	Maximum 300 points	Maximum 380 points

■ Expansion Cable Combination Limitations

- Please limit the total length of the expansion cable to less than 160 cm.

■ Expansion Cable Combination Limitations (2)

- The number of expansion units can be connected and expanded varies with its types.

	Unit Type	Remarks
①	FP-XH Control Unit	
②	FP-X Expansion I/O Unit	E14YR, E16R
		E16X, E16T, E16P Ver.3.0 or below
③	FP-X Expansion I/O Unit	E16X, E16T, E16P Ver.3.0 or above
	FP-X0 Expansion I/O Unit	E24R, E24T, E24P
④	FP-X Expansion I/O Unit	E30
	FP-X0 Expansion I/O Unit	E40

- In the FP-X expansion I/O unit, connecting two units in group ② shown in the above table is not possible. However, it can be expanded on the right side of the expansion I/O unit with built-in power supply.

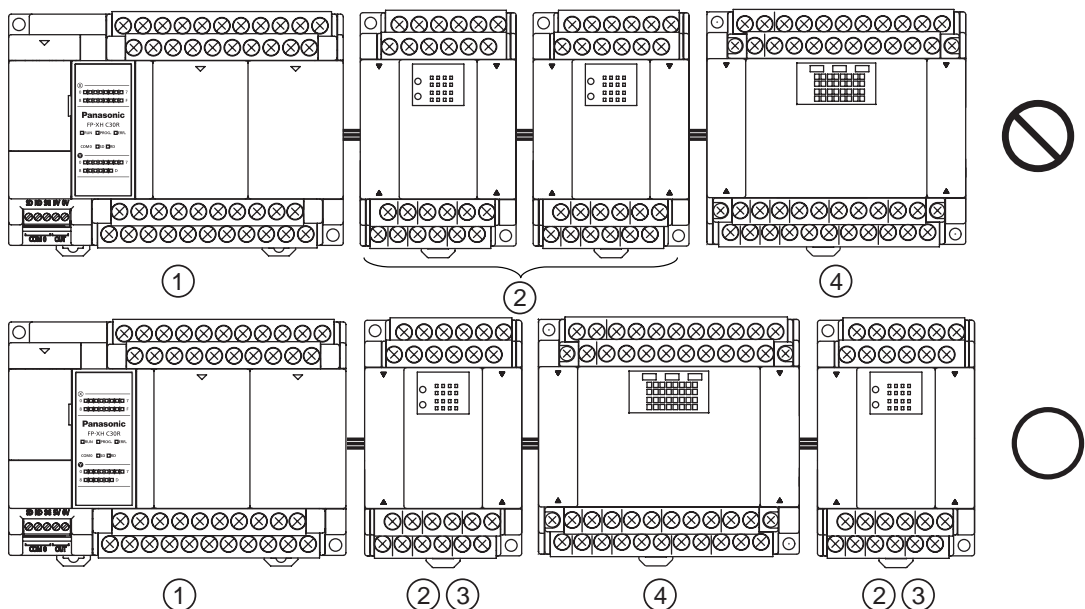

- In the FP-X expansion I/O unit and unit without built-in power supply, up to three units in group ③ shown in the above table can be connected.

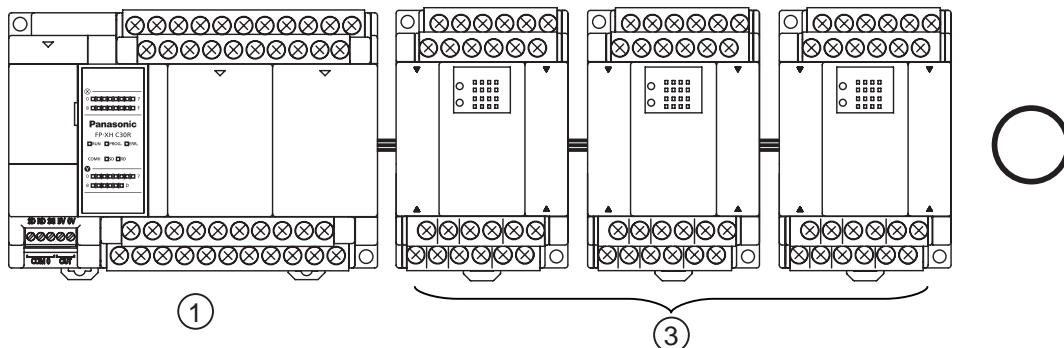

1.3.2 Use Restrictions of FP-X Expansion Adapter

■ Expansion position of FP-X expansion FP0 adapter

- With the FP-X expansion FP0 adapter, up to three FP0 expansion units can be connected.
- When using the FP-X expansion FP0 adapter, up to seven FP-X expansion units can be connected.
- The end of the FP-X expansion bus can only connect with one FP-X expansion FP0 adapter. Please expand on the right side of FP-X / FP-X0 expansion units.

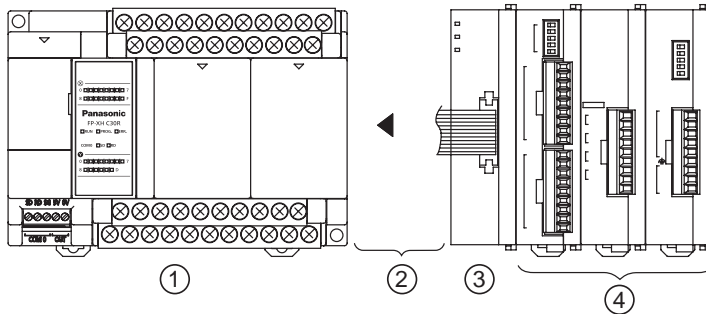

①	FP-XH Control Unit	②	FP-X / FP-X0 Expansion Unit	③	FP-X Expansion FP0 Adapter	④	FP0 Expansion Unit High Function Unit
---	-----------------------	---	-----------------------------------	---	----------------------------------	---	--

■ Expansion sequence of FP0 expansion unit / FP0 high functional unit

- Please connect the FP0 thermocouple input unit to the right side of the other FP0 units. Connecting to the left side reduces overall accuracy.
- Please connect the FP0 CC-Link unit to the right side of the other FP0 units. No expansion connector.

1.3.3 Limitations on Expansion Card Combination

■ Expansion card installation position (1)

- The FP-XH control unit contains 2 expansion card installation parts. C14 only has card installation part 1.

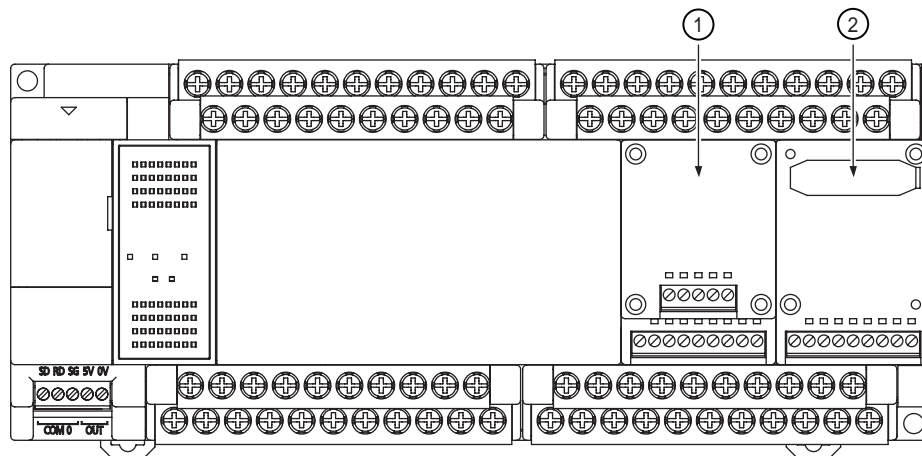

①	Card installation part 1	②	Card installation part 2
---	--------------------------	---	--------------------------

■ Expansion card installation position (2)

- Function and communication card can be overlapped and installed into the same card installation part. In this case, make sure the communication card is installed over the function card.

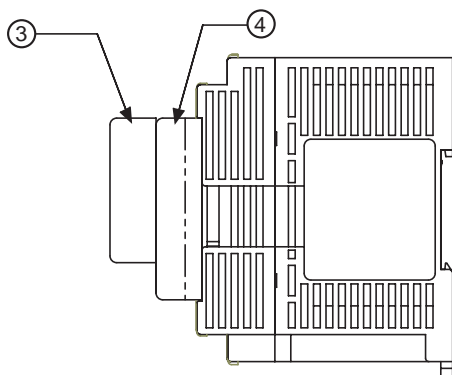

③	Communication card	④	Function card
---	--------------------	---	---------------

■ Expansion card installation number

- Up to two function plugs and two communication plugs can be installed.

- Expansion card type and installation location (●: available, ○: conditional, no notation: not available)

Card type			Installation part of the control unit	
			Card installation part 1	Card installation part 2
Type	Product Name	No.	C14 / C30 / C40 / C60	C30 / C40 / C60
Communication card (note 1)	Communication card	AFPX-COM1	○ (note 2)	○ (note 2)
		AFPX-COM2	●	●
		AFPX-COM3	●	●
		AFPX-COM4	●	●
		AFPX-COM5	●	●
		AFPX-COM6	●	●
Function card (Note 3)	Analog input card	AFPX- AD2	●	●
	Analog output card	AFPX-DA2	●	●
	Analog I/O card	AFPX-A21	●	●
	Thermocouple card	AFPX-TC2	●	●
	Temperature measuring resistor card	AFPX-RTD2	●	●
	Input card	AFPX-IN8	●	●
	Output card	AFPX-TR8	●	●
	Output card	AFPX-TR6P	●	●
	Input / output card	AFPX-IN4T3	●	●
	Pulse input / output card	AFPX-PLS	○ (note 4)	○ (note 4)
	Main memory card	AFPX-MRTC	○ (note 5)	○ (note 5)

(Note 1): When installed with the function card together, mount it over the function card.

(Note 2): RS / CS control available for AFPX-COM1.

(Note 3): When installing the function card on C30, C40 and C60, it can be installed at card installation part 1 or card installation part 2.

(Note 4): You can not install pulse input and output card on the transistor output type control unit. If installed, a self-diagnosis error will occur (27: Unit installation is restricted).

(Note 5): Only one FP-X main memory card can be installed. A self-diagnosis error will occur if 2 sets are installed (27: Unit installation is restricted).

1.3.4 Use limitations on Communication Function

- When using the standard communication port and communication card of the control unit, the following limitations exist depending on the different functions of use.
- The communication port number assigned varies according to the card installation position.

■ Type of communication port / communication card (●: available, no notation: not available)

Order Number	Communication Interface	Communication Port No. Assigned				
		Main unit	Card installation part 1		Card installation part 2	
		COM0	COM1	COM2	COM3	COM4
Control unit standard configuration	RS-232C (3-wire) × 1 channel	●				
AFPX-COM1	RS-232C (5-wire) × 1 channel		●		●	
AFPX-COM2	RS-232C (3-wire) × 2 channel		●	●	●	●
AFPX-COM3	RS-485 / RS-422 × 1 channel		●		●	
AFPX-COM4	RS-485 × 1 channel		●		●	
	RS-232C (3-wire) × 1 channel			●		●
AFPX-COM5	Ethernet × 1 channel		●		●	
	RS-232C (3-wire) × 1 channel			●		●
AFPX-COM6	RS-485 × 2 channel		●	●	●	●

(Note 1): With 5-wire RS-232C, the RS / CS control can be enabled for the RS-232C port of the AFPX-COM1.

(Note 2): Choose either of the RS-485 or RS-422 when using AFPX-COM3. It can be shifted by the switch on the communication card.

(Note 3): AFPX-COM4 can use RS-485 × 1 channel and RS-232C (3-wire) × 1 channel.

(Note 4): AFPX-COM5 can use Ethernet × 1 channel and RS-232C (3-wire) × 1 channel.

■ Function of the communication port (●: available, ○: conditional, no notation: not available)

Communication function used		Communication Port No. Assigned				
		Main unit	Card installation part 1		Card installation part 2	
		COM0	COM1	COM2	COM3	COM4
PLC Link		○	○			
MEWTOCOL-COM	Master station	●	●	●	●	●
	Slave station	●	●	●	●	●
MODBUS-RTU	Master station	●	●	●	●	
	Slave station	●	●	●	●	
General communication		●	●	●	●	

(Note 1): PLC link can only use either the COM0 port comes with the control unit or COM1 port on the card.

(Note 2): The COM4 port only supports MEWTOCOL-COM communication. In addition, the communication parameters (station number, communication format, communication speed) when the power is ON are same as the settings of the COM3 port. After RUN, you can also change the conditions by SYS1 instruction.

1.3.5 Limitations on Function Combination

- Combining FP-XH series with the COM0 port, communication plug-in COM1 - COM4 ports come with the main body, up to 5 communication interfaces can be used to communicate with external machine.
- When all 5 ports of the COM0 - COM4 are used, the maximum speed of communication is 115.2 kbps, and pulse output functions of up to 2 axes can be used. When 4 or less communication ports are used, the maximum speed of communication is 230.4 kbps, and pulse output functions of up to 6 axes can be used.

1.4 Programming Tools

1.4.1 Required Tools

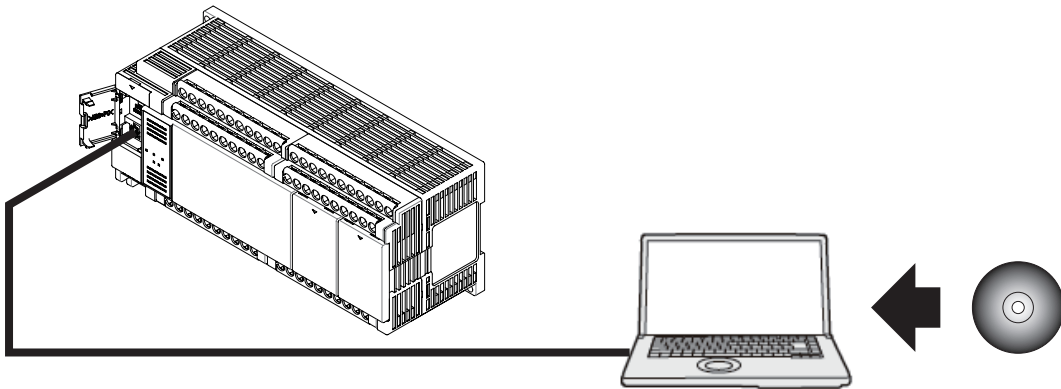

1.4.2 Software Environment and Applicable Cables

■ Standard trapezoidal software FPWIN GR Ver.2

Software Category	OS	Hard Drive Capacity	Order Number
FPWIN GR Ver.2 (Chinese)	Windows®7 (32 bit / 64 bit)	40MB or more	AFPS10820

(Note 1): When upgrading from Ver2 to the latest version, you can use the company HP (http://industrial.panasonic.com/ac/c/dl_center/software/) for a free upgrade. Please use the latest version.

■ Computer connection cable

- Use a commercially available USB cable.

Cable Type	Length
USB 2.0 cable (A: miniB)	Up to 5 m

1.4.3 Corresponding Version of the Software

The following versions of software are required for using the FP-XH.

Item	Corresponding Version
Programming Tool Software FPWIN GR	Ver.2.93 or later
Configurator PMX	Use it after using the pulse output function based on the data sheet setting mode. Embedded in the FPWIN GR, started through the "Options" menu.

2

Control Unit Specifications

2.1 Name and Function of Each Part

2.1.1 Name and Function of Each Part

■ FP-XH C14 control unit

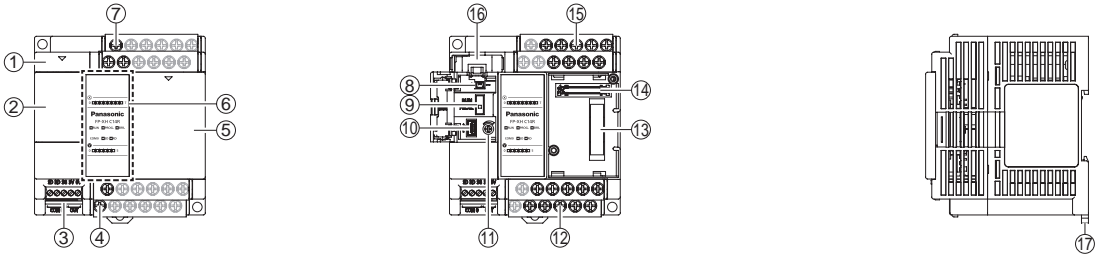

■ FP-XH C30 control unit

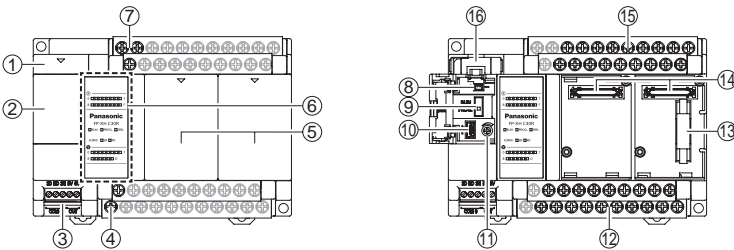

■ FP-XH C40 control unit

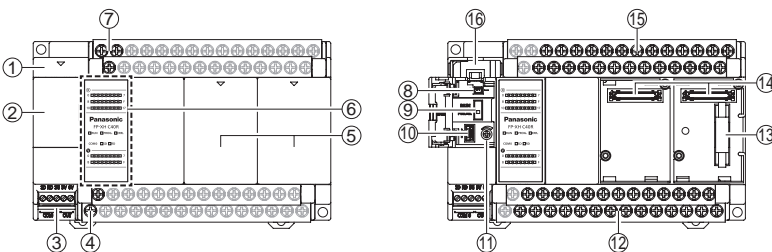

■ FP-XH C60 control unit

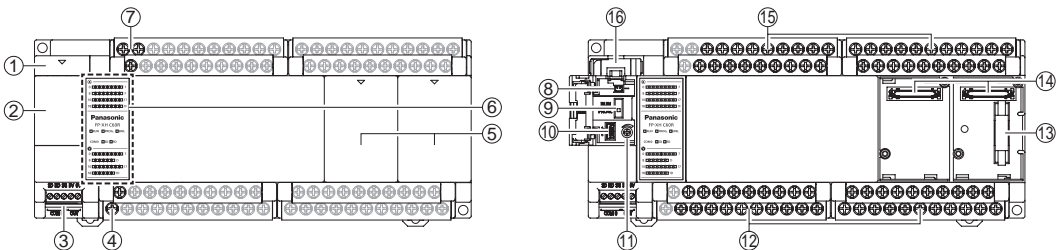

(Note): The side is universal for all models.

■ Name and Function of Each Part

No.	Name	Function
①	Battery cover	Backup battery insertion space for options.
②	Operating unit cap	Has built-in battery connector, RUN / PROG. mode switch, USB port connector and analog potentiometer.
③	COM0 port	3-wire RS-232C port. Also equipped with a 5V power supply terminal for connecting to GT series monitor.
④	General power supply terminals for input	Can be used as a universal power supply for input circuit.
⑤	Card installation part cover	Installation space for communication card and function card of the options.
⑥	Status display LED / input / output display LED	Displays operation mode, error conditions and the communication status and input / output status of the COM0 port.
⑦	Power supply terminals	Connected to the drive control unit power supply.
⑧	Battery connector	Insert special battery (AFPXHBATT) connector.
⑨	RUN / PROG. mode switch	RUN (upper) Set to RUN mode. Program execution begins.
		PROG (lower) Set to programming mode.
⑩	USB port connector	Connecting to a PC using the tool software.
⑪	Analog potentiometer	The special DT value changes when rotating potentiometer. It can be applied to analog timers etc.
⑫	Output terminal	Connect with the output device.
⑬	Expansion unit connector	Connect with an expansion cable for installing expansion unit.
⑭	Expansion card connector	For installing an optional expansion card (communication card or function card).
⑮	Input terminal	Connect with input devices.
⑯	Battery holder	When using the calendar clock function, it is used to install a special battery when expanding the backup area of memory area for operation. The special Battery (AFPXHBATT) is required to purchase separately.
⑰	DIN hook	Used for DIN rail fixing.

(Note 1): Whether the switch is on "RUN" or "PROG", the mode can be switched by tool software via remote operation. When the power is reconnected, it will operate under the mode at the switch position.

2.1.2 Action Display LED Unit Specifications

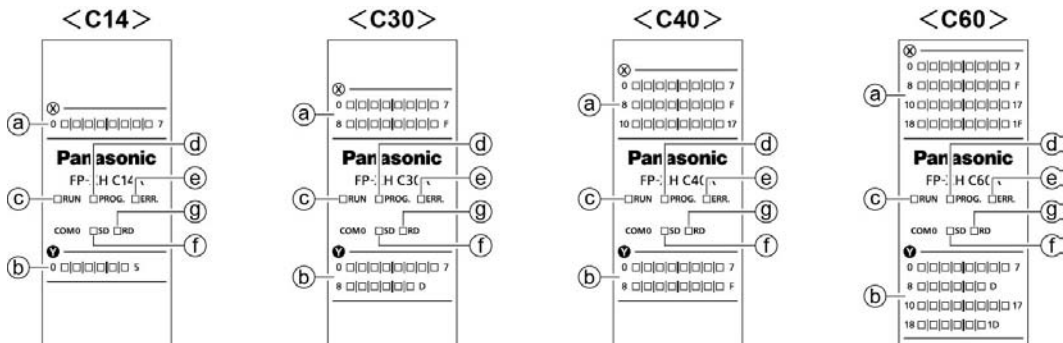

No.	Controller Display		Color	Display Content	
(a)	X		Green	Indicate the status of inputs.	
(b)	Y		Green	Indicate the status of outputs.	
(c)	RUN	Green	Lights	Lighted when running the program in RUN mode.	
			Flashes	When performing the mandatory input and output function, RUN / PROGLED will flash alternately.	
(d)	PROG.	Green	Lights	Lighted when stopping running in PROG. mode.	
			Flashes	When performing the mandatory input and output function, RUN / PROGLED will flash alternately.	
(f)	COM0	SD	Green	Flashes when sending from the COM0 port.	
(g)		RD	Green	Flashes when receiving from the COM0 port.	
(e)	ERR	Red	Flashes	Lit when detecting errors through self diagnosis.	
			Lights	The light is on during hardware exceptions, program operation stagnation and monitoring timer operation.	

2.1.3 COM0 Port Specifications

- Universal 3-wire RS-232C port.
- Equipped with a 5 V power supply terminal for supplying power to the GT02 / GT02L series programmable display.

■ Terminal arrangement

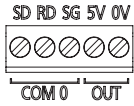

Controller Display		Description	
COM 0	SD	Send data (unit → external device)	Universal 3-wire RS-232C port.
	RD	Receive data (external device → unit)	
	SG	Signal ground	
OUT	5V	As power supply for GT series display, 5 VDC output.	
	0V		

2.2 Power Specifications

2.2.1 AC Power Supply Type

■ AC Power Supply Type

Item		Specification	
		C14	C30 / C40 / C60
Rated voltage		100 - 240 VAC	
Allowable voltage range		85 - 264 VAC	
Impact current (240 VAC, at 25°C ambient temperature)		45 A or less	
Allowable temporal outage time		10 ms (when using 200 VAC)	
Frequency		50 / 60Hz (47 - 63Hz)	
Leakage current		0.75 mA or less between input - protection ground terminals	
Built-in power supply unit to ensure long service life		30,000 hours (at 55°C ambient temperature)	
Fuse		Built-in (not replaceable)	
Insulation mode		Transformer insulation	
Terminal screw		M3	
Current consumption	100 VAC	C14R : 185 mA or less C14T : 175 mA or less	C30R : 330 mA or less C30T : 310 mA or less C40R : 345 mA or less C40T : 320 mA or less C60R : 380 mA or less C60T : 335 mA or less
	200 VAC	C14R : 115 mA or less C14T : 110 mA or less	C30R : 200 mA or less C30T : 190 mA or less C40R : 215 mA or less C40T : 195 mA or less C60R : 235 mA or less C60T : 205 mA or less

2.2.2 AC Power Supply Type: Universal Power Supply for Input Circuit

■ AC Power Supply Type: Specifications of Universal Power Supply for Input Circuit

Item		Specification	
		C14	C30 / C40 / C60
Rated voltage		24 VDC	
Allowable voltage range		21.6 - 26.4 VDC	
Rated output current		0.15A	0.4A
Over-current protection		Yes	
Terminal screw		M3	

2.2.3 DC Power Supply Type

■ DC Power Supply Type

Item	Specification
	C14 / C30 / C40 / C60
Rated voltage	24 VDC
Allowable voltage range	21.6 - 26.4 VDC
Impact current	12 A or less (24 VAC, at 25°C ambient temperature)
Allowable temporal outage time	10 ms
Built-in power supply unit to ensure long service life	30,000 hours (at 55°C ambient temperature)
Fuse	Built-in (not replaceable)
Insulation mode	Non-insulated
Terminal screw	M3
Current consumption	C14R : 95 mA or less C14T : 90 mA or less C30R : 160 mA or less C30T : 115 mA or less C40R : 185 mA or less C40T : 130 mA or less C60RD : 275 mA or less C60TD : 170 mA or less

2.3 Input and Output Specifications (Relay Output Type)

2.3.1 Input Specifications

■ Specification

Item	Specification			
	C14R	C30R	C40R	C60R
Insulation mode	Optocoupler insulation			
Rated input voltage	24 VDC			
Service voltage range	21.6 - 26.4 VDC			
Rated input current	Appr. 4.7mA (X0 - X7) / appr. 4.3mA (X8 and above)			
COM mode	8 points / COM	16 points / COM	24 points / COM	16 points / COM × 2
	(± polarity of the input power supply are both allowable)			
Minimum ON voltage / minimum ON current	19.2 VDC / 3 mA			
Maximum OFF voltage / maximum OFF current	2.4 VDC / 1 mA			
Input resistance	5.1 kΩ (X0 - X7) / 5.6 kΩ (X8 and above)			
Response time (note)	OFF → ON	X0 - X7	0.6 ms or less (general input) 50 μs or less (high-speed counter, pulse catch, interrupt input setting)	
		X8 and above	0.6 ms or less	
	ON → OFF	Ditto		
Action indication	LED			
EN61131-2 applicable	TYPE3 reference (required to follow the above specifications)			

(Note): Specifications at rated 24 VDC, 25°C ambient temperature.

■ Internal circuit diagram

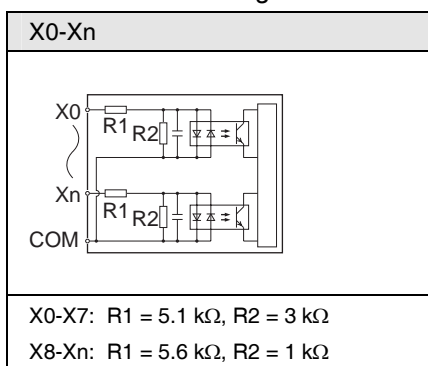

2.3.2 Output Specifications

■ Specification

Item	Specification			
	C14R	C30R	C40R	C60R
Insulation mode	Relay insulation			
Output type	1a relay output			
Rated control capacity	2 A 250 VAC, 2 A 30 VDC (resistive load)			
	Each COM	6 A or less	8 A or less	
COM mode	1 point COM × 3 3-point COM × 1	1 point COM × 2 4-point COM × 3	1 point COM × 2 2-point COM × 1 4-point COM × 3	1 point COM × 6 2-point COM × 1 4-point COM × 5
Response time	OFF → ON	About 10 ms		
	ON → OFF	About 8 ms		
Lifetime	Mechanical	More than 20 million times (on-off frequency of 180 times/min)		
	Electrical	More than 0.1 million times (on-off frequency of 20 times/min at rated control capacity)		
Action indication	LED			
EN61131-2 applicable	TYPE3 reference (required to follow the above specifications)			

■ Internal circuit diagram

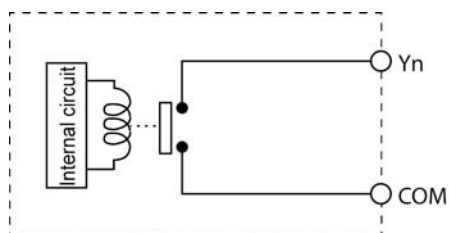

2.4 Input and Output Specifications (Transistor Output Type)

2.4.1 Input Specifications

■ Specification

Item		Specification			
		C14T	C30T	C40T	C60T
Insulation mode		Optocoupler insulation			
Rated input voltage		24 VDC			
Service voltage range		21.6 - 26.4 VDC			
Rated input current		Appr. 12 mA (X0 - X3) / appr. 4.7 mA (X4 - X7) / appr. 4.3 mA (X8 and above)			
COM mode		8 points / COM	16 points / COM	24 points / COM	16 points / COM × 2
		(± polarity of the input power supply are both allowable)			
Minimum ON voltage / minimum ON current		19.2 VDC / 3 mA			
Maximum OFF voltage / maximum OFF current		2.4 VDC / 1 mA			
Input resistance		Appr. 2 kΩ (X0 - X3) / appr. 5.1 kΩ (X4 - X7) / appr. 5.6 kΩ (X8 and above)			
Response time (note)	OFF → ON	X0 - X3	135 μs or less (general input) 5 μs or less (high-speed counter, pulse catch, interrupt input setting)		
		X4 - X7	135 μs or less (general input) 50 μs or less (high-speed counter, pulse catch, interrupt input setting)		
		X8 and above	0.6 ms or less		
	ON → OFF	Ditto			
Action indication		LED			
EN61131-2 applicable		TYPE3 reference (required to follow the above specifications)			

(Note): Specifications at rated 24 VDC, 25°C ambient temperature.

■ Internal circuit diagram

X0-X3	X4-Xn
R1 = 2 kΩ, R2 = 680 kΩ	X4-X7: R1 = 5.1 kΩ, R2 = 3 kΩ X8-Xn: R1 = 5.6 kΩ, R2 = 1 kΩ

2.4.2 Output Specifications

■ Specification

Item	Specification			
	C14T	C30T	C40T	C60T
Insulation mode	Optocoupler insulation			
Output type	NPN open collector			
Rated load voltage	5 - 24 VDC			
Allowable load voltage range	4.75 - 26.4 VDC			
Rated load current	0.5 A			
Maximum impact current	1.5 A			
OFF leakage current	1 μ A or less			
ON maximum voltage drop	0.3 VDC or less			
COM mode	6-point COM	6 point COM \times 1 8-point COM \times 1	8-point COM \times 2	6 point COM \times 2 8-point COM \times 2
Response time (note)	OFF \rightarrow ON	2 μ s or less (Y0-Y5)	2 μ s or less (Y0-Y7) 1 ms or less (Y8 -)	2 μ s or less (Y0-YB) 1 ms or less (YC -)
	ON \rightarrow OFF	8 μ s or less (Y0-Y5)	8 μ s or less (Y0-Y7) 1 ms or less (Y8 -)	8 μ s or less (Y0-YB) 1 ms or less (YC -)
Surge suppressor	Zener diode			
Action indication	LED			
EN61131-2 applicable	TYPE3 reference (required to follow the above specifications)			

(Note) Specifications at 25°C ambient temperature.

■ Internal circuit diagram

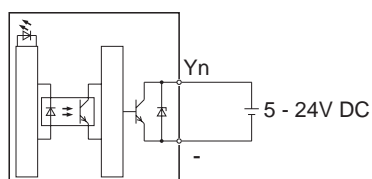

2.5 Terminal arrangement

2.5.1 Relay Output AC Power Supply Type

■ AFPXHC14R

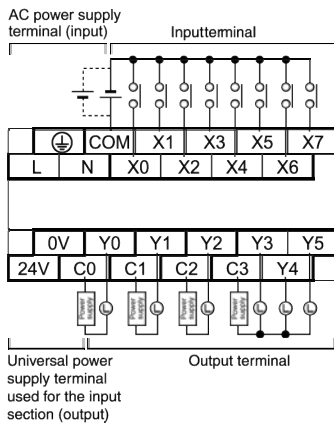

■ AFPXHC30R

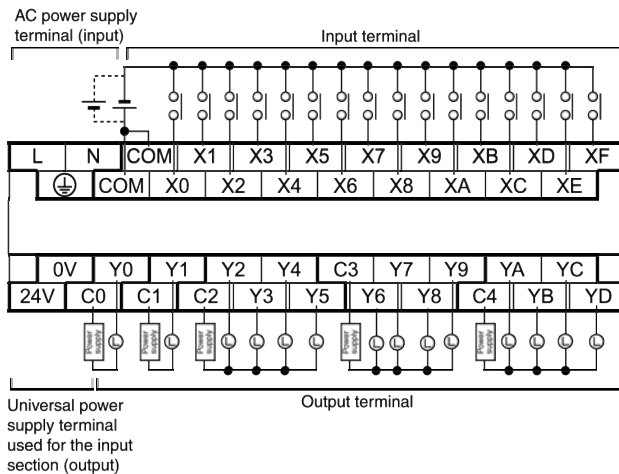

■ AFPXHC40R

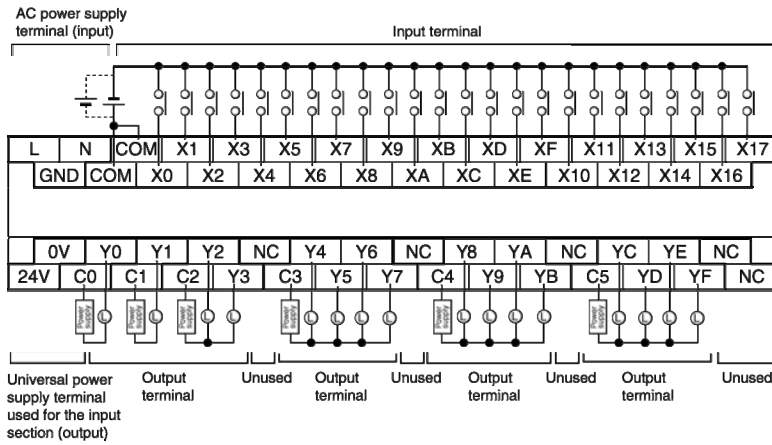

■ AFPXHC60R

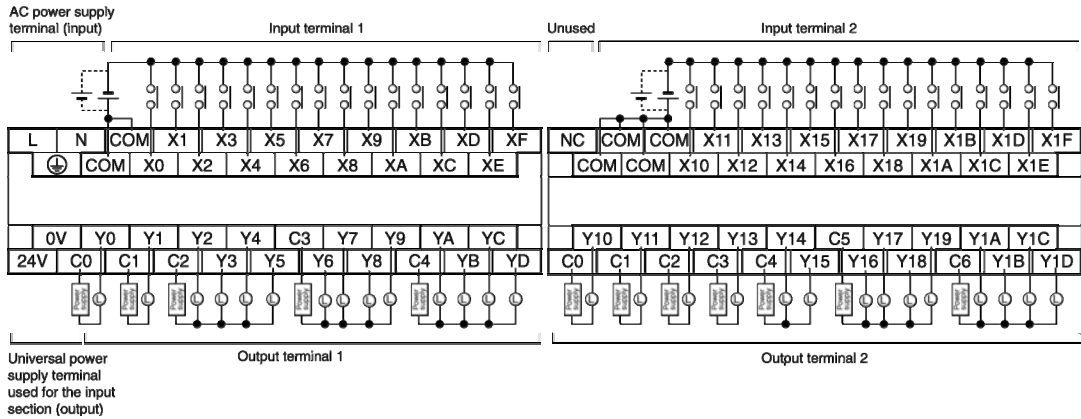

Input terminals: COM terminals within the same terminal block have been connected inside the unit. However, the input terminal 1 of C60 and the COM of input terminal 2 are independent. (Not connected internally)
 Output terminals: COM terminals (C0, C1...) are independent. Please use within the enclosed range.

2.5.2 Relay Output DC Power Supply Type

■ AFPXHC14RD

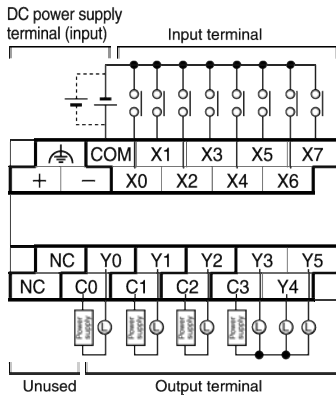

■ AFPXHC30RD

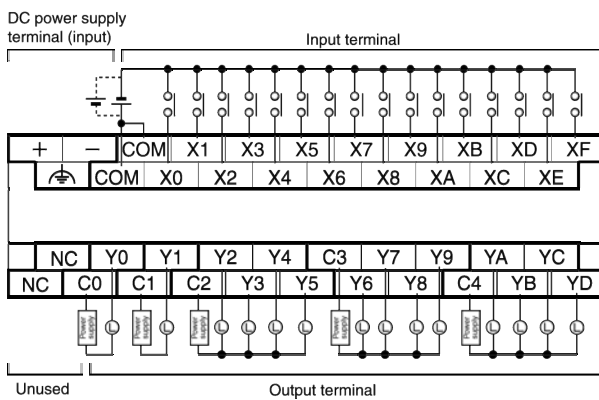

■ AFPX-C40RD

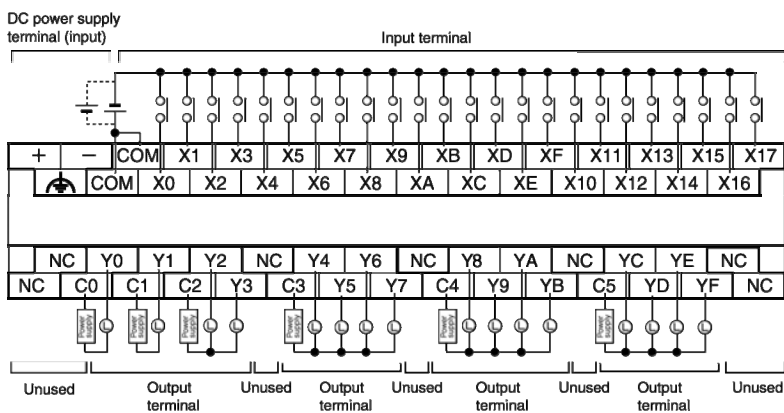

■ AFPXC60RD

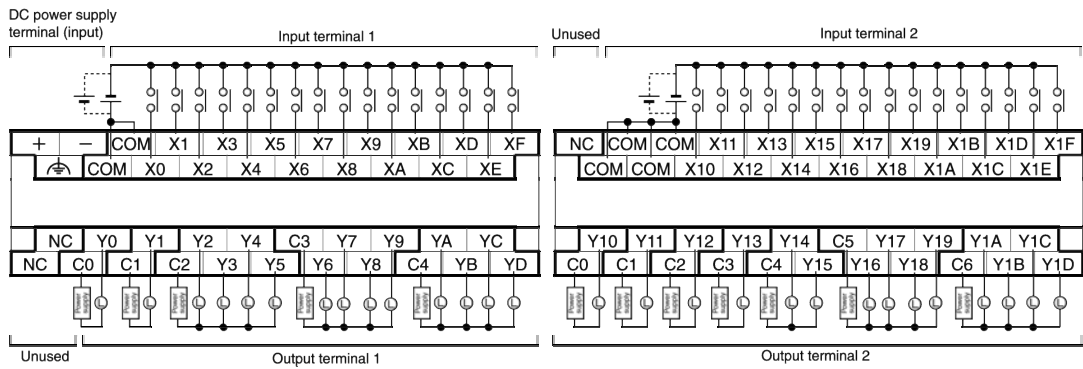

Input terminals: COM terminals within the same terminal block have been connected inside the unit. However, the input terminal 1 of C60 and the COM of input terminal 2 are independent. (Not connected internally)

Output terminals: COM terminals (C0, C1...) are independent. Please use within the enclosed range.

2.5.3 Transistor Output AC Power Supply Type

■ AFPXHC14T

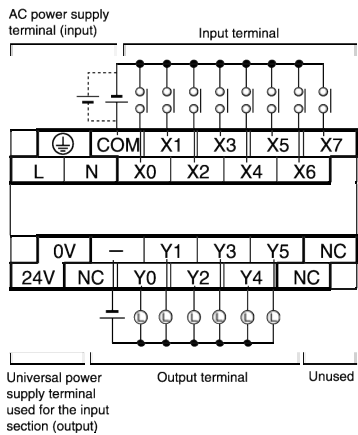

■ AFPXHC30T

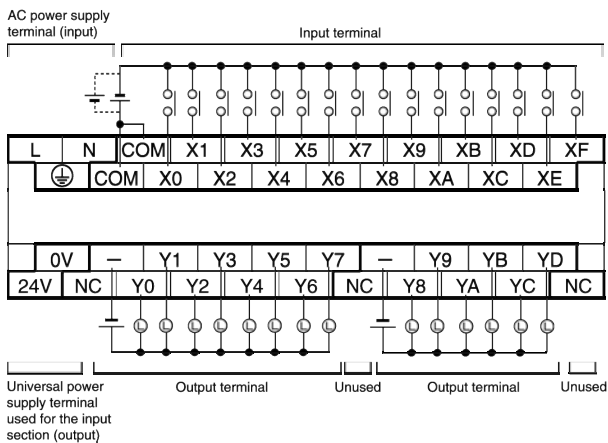

■ AFPXHC40T

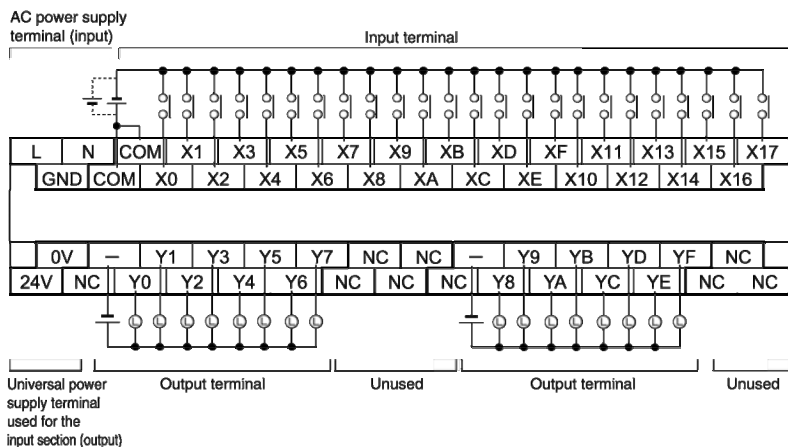

■ AFPXHC60T

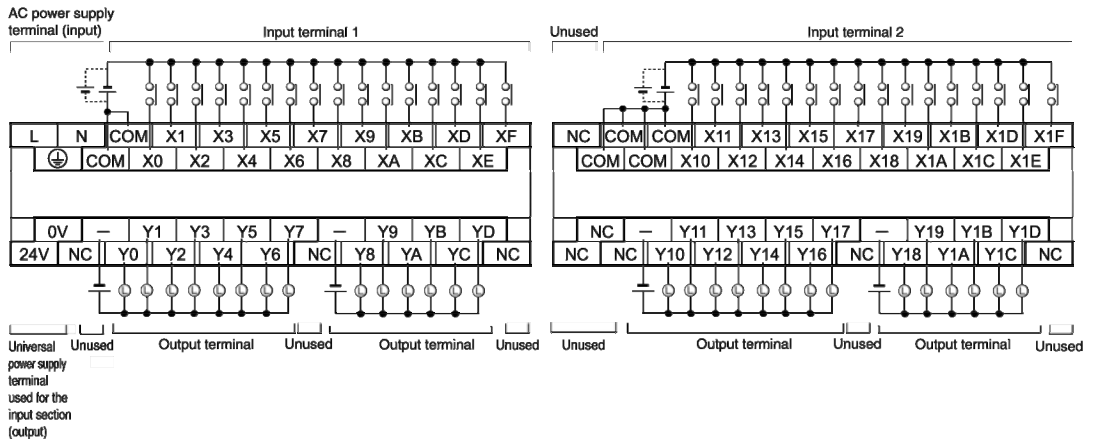

Input terminals: COM terminals within the same terminal block have been connected inside the unit. However, the input terminal 1 of C60 and the COM of input terminal 2 are independent. (Not connected internally)

Output terminals: COM terminals within the same terminal block have been connected inside the unit.

2.5.4 Transistor Output DC Power Supply Type

■ AFPXHC14TD

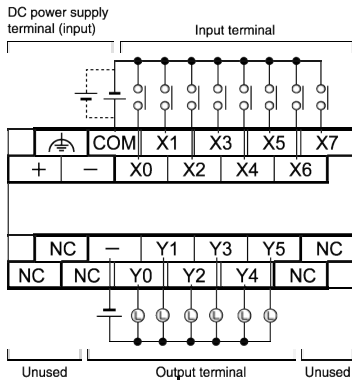

■ AFPXHC30TD

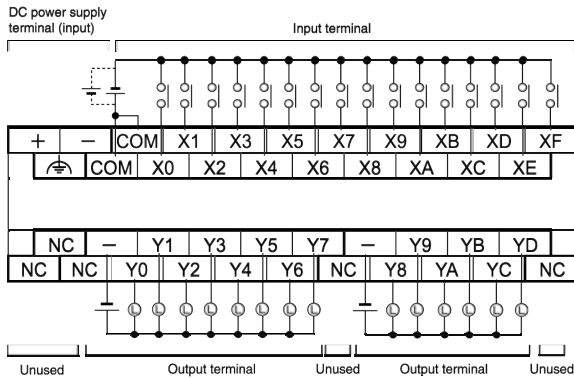

■ AFPXHC40TD

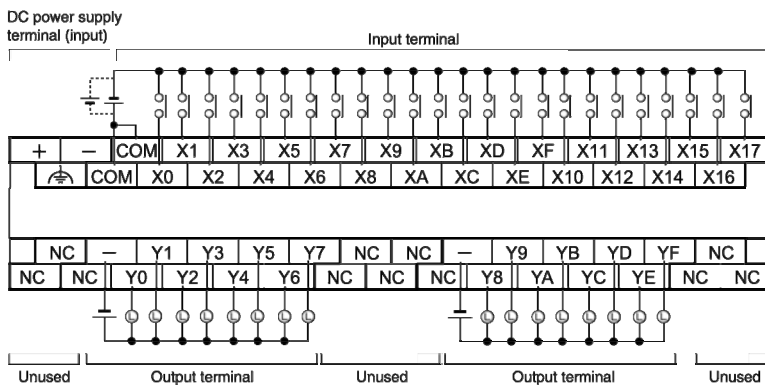

■ AFPXC60TD

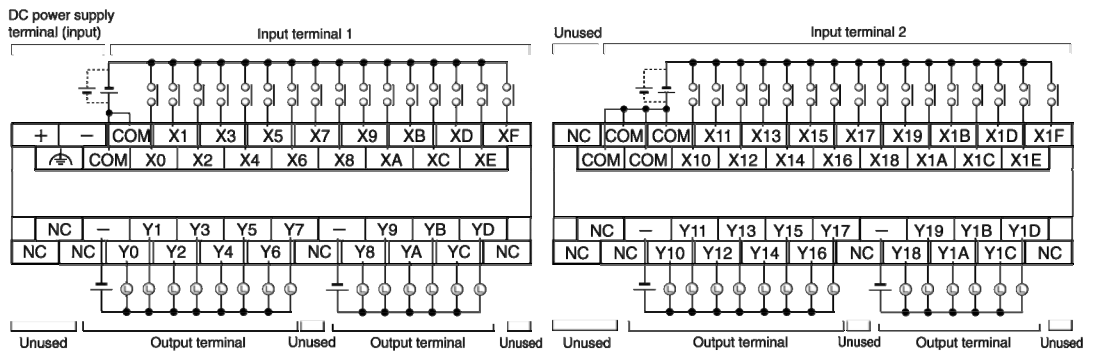

Input terminals: COM terminals within the same terminal block have been connected inside the unit. However, the input terminal 1 of C60 and the COM of input terminal 2 are independent. (Not connected internally)

Output terminals: COM terminals within the same terminal block have been connected inside the unit.

3

I/O Number Assignment

3.1 Basic I/O Assignment

3.1.1 Counting Method of I/O Numbers

■ Counting method and representation of I/O numbers

- I/O numbers are counted in 16 points, representing the next bit combination of device type symbol and decimal and hexadecimal numbers.
- For external input, represented as X0-X9, XA-XF. For external output, represented as Y0-Y9, YA-YF.



3.1.2 I/O Number Assignment Method

■ I/O numbers of control unit

I/O numbers are assigned a fixed area.

■ I/O numbers of expansion unit

The starting number assigned to each expansion unit will change depending on the installation location.

■ I/O number assigned to each function card

Depending on the installation location, I/O number assigned a fixed area.

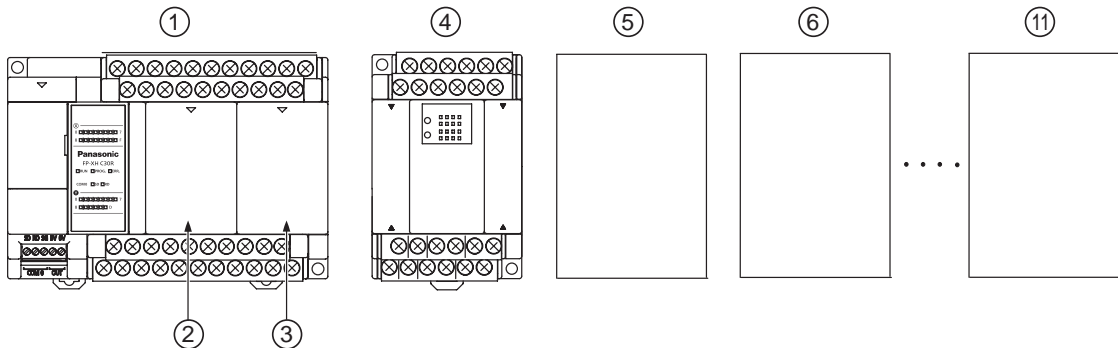

■ I/O numbers list

Unit Type and Installation Location		Input		Output	
		I/O Number		I/O Number	
①	Control unit	X0-X9F	WX0-WX9	Y0-Y9F	WY0-WY9
②	Card installation part 1 (slot 0)	X100-X19F	WX10-WX19	Y100-Y19F	WY10-WY19
③	Card installation part 2 (slot 1)	X200-X29F	WX20-WX29	Y200-Y29F	WY20-WY29
④	1st expansion	X300-X39F	WX30-WX39	Y300-Y39F	WY30-WY39
⑤	2nd expansion	X400-X49F	WX40-WX49	Y400-Y49F	WY40-WY49
⑥	3rd expansion	X500-X59F	WX50-WX59	Y500-Y59F	WY50-WY59
⑦	4th expansion	X600-X69F	WX60-WX69	Y600-Y69F	WY60-WY69
⑧	5th expansion	X700-X79F	WX70-WX79	Y700-Y79F	WY70-WY79
⑨	6th expansion	X800-X89F	WX80-WX89	Y800-Y89F	WY80-WY89
⑩	7th expansion	X900-X99F	WX90-WX99	Y900-Y99F	WY90-WY99
⑪	8th expansion	X1000-X109F	WX100-WX109	Y1000-Y109F	WY100-WY109

(Note): The I/O number can be used practically varies from the types of cards and expansion units.

3.2 List of I/O Numbers for Units

3.2.1 FP-XH Control Unit

■ I/O numbers list

Unit Type	Input		Output	
	Input Points	I/O Number	Output Points	I/O Number
C14	8 points	X0-X7	6 points	Y0-Y5
C30	16 points	X0-X9, XA-XF	14 points	Y0-Y9, YA-YD
C40	24 points	X0-X9, XA-XF X10-X17	16 points	Y0-Y9, YA-YF
C60	32 points	X0-X9, XA-XF X10-X19, X1A-X1F	28 points	Y0-Y9, YA-YD Y10-Y19, Y1A-Y1D

3.2.2 FP-X Expansion Unit

■ I/O numbers list

Unit Type	Input		Output	
	Input Points	I/O Number	Output Points	I/O Number
E16	8 points	X300-X307	8 points	Y300-Y305
E30	16 points	X300-X309, X30A-X30F	14 points	Y300-Y309, Y30A-Y30D
E16X	16 points	X300-X309, X30A-X30F	-	-
E14YR	-	-	14 points	Y300-Y309, Y30A-Y30D

(Note): I/O numbers in the above table represent the I/O number for expansion units connected to the first unit. The I/O number varies from the installation order.

3.2.3 FP-X0 Expansion Unit

■ I/O numbers list

Unit Type	Input		Output	
	Input Points	I/O Number	Output Points	I/O Number
E24	16 points	X300-X309, X30A-X30F	8 points	Y300-Y307
E40	24 points	X300-X309, X30A-X30F X310-X317	16 points	Y300-Y309, Y30A-Y30F

(Note): I/O numbers in the above table represent the I/O number for expansion units connected to the first unit. The I/O number varies from the installation order.

3.2.4 FP-X Function Card

■ I/O numbers list (analog input and output cards)

Installation location	Type	Input		Output	
		Input Points	I/O Number	Output Points	I/O Number
Insert card install part 1	Analog input card AD2	2ch	WX10, WX11	-	-
	Analog output DA2	-	-	2ch	WY10, WY11
	Analog input and output card A21	2ch	WX10, WX11	1ch	WY10
	TC2 thermocouple input card	2ch	WX10, WX11	-	-
	Temperature measuring resistor card RTD2	2ch	WX10, WX11	-	-
Insert card install part 2	Analog input card AD2	2ch	WX20, WX21	-	-
	Analog output DA2	-	-	2ch	WY20, WY21
	Analog input and output card A21	2ch	WX20, WX21	1ch	WY20
	TC2 thermocouple input card	2ch	WX20, WX21	-	-
	Temperature measuring resistor card RTD2	2ch	WX20, WX21	-	-

■ I/O numbers list (digital input and output cards)

Installation location	Type	Input		Output	
		Input Points	I/O Number	Output Points	I/O Number
Insert card install part 1	Input card IN8	8 points	X100-X107	-	-
	Output card TR8	-	-	8 points	Y100-Y107
	Output card TR6P	-	-	6 points	Y100-Y105
	Input and output card IN4T3	4 points	X100-X103	3 points	Y100-Y102
Insert card install part 2	Input card IN8	8 points	X200-X207	-	-
	Output card TR8	-	-	8 points	Y200-Y207
	Output card TR6P	-	-	6 points	Y200-Y205
	Input and output card IN4T3	4 points	200-X203	3 points	Y200-Y202

■ I/O numbers list (pulse input and output cards)

Installation location	Type	Input		Output	
		Input Points	I/O Number	Output Points	I/O Number
Insert card install part 1	High speed counter	3 points	X100-X102	-	-
	Pulse output	-	-	3 points	Y100-Y102
Insert card install part 2	High-speed counter input	3 points	X200-X202	-	-
	Pulse output	-	-	3 points	Y200-Y202

3.3 Assignment of FP0 Expansion Units

3.3.1 I/O Number Assignment Method

- I/O numbers of FP0 expansion units and FP0 high function units
- The starting number assigned to each FP0 expansion block varies from the installation location of FP-X expansion FP0 adapters.
- The starting number assigned to each unit varies from the installation sequences of FP0 expansion units and FP0 high function units.

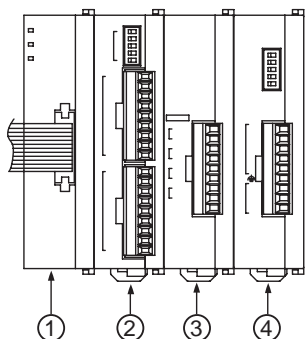

①	FP-X Expansion FP0 Adapter	②	FP0 Expansion Unit 1	③	FP0 Expansion Unit 2	④	FP0 Expansion Unit 3
---	----------------------------	---	----------------------	---	----------------------	---	----------------------

■ I/O numbers list

FP-X Expansion FP0 Adapter Installation Location	Installation Sequence of FP0 Expansion Units					
	Expansion Unit 1		Expansion Unit 2		Expansion Unit 3	
	Input	Output	Input	Output	Input	Output
1st Expansion	X300-X31F	Y300-Y31F	X320-X33F	Y320-Y33F	X340-X35F	Y340-Y35F
2nd expansion	X400-X41F	Y400-Y41F	X420-X43F	Y420-Y43F	X440-X45F	Y440-Y45F
3rd expansion	X500-X51F	Y500-Y51F	X520-X53F	Y520-Y53F	X540-X55F	Y540-Y55F
4th expansion	X600-X61F	Y600-Y61F	X620-X63F	Y620-Y63F	X640-X65F	Y640-Y65F
5th expansion	X700-X71F	Y700-Y71F	X720-X73F	Y720-Y73F	X740-X75F	Y740-Y75F
6th expansion	X800-X81F	Y800-Y81F	X820-X83F	Y820-Y83F	X840-X85F	Y840-Y85F
7th expansion	X900-X91F	Y900-Y91F	X920-X93F	Y920-Y93F	X940-X95F	Y940-Y95F
8th expansion	X1000 -X101F	Y1000 -Y101F	X1020 -X103F	Y1020 -Y103F	X1040 -X105F	Y1040 -Y105F

(Note): The I/O number can be used practically varies from the types of cards and expansion units.

3.3.2 Types and I/O Numbers of FP0 Expansion Units

I/O numbers when the FP-X expansion FP0 adapter connecting as the first expansion unit of the control unit are shown below.

■ I/O numbers list (first expansion unit)

Unit Type		Points Assigned	Expansion Unit 1	Expansion Unit 2	Expansion Unit 3
FP0R expansion unit	FP0R-E8X	Input (8 points)	X300 - X307	X320 - X327	X340 - X347
	FP0R-E8R	Input (4 points)	X300 - X303	X320 - X323	X340 - X343
		Output (4 points)	Y300 - Y303	Y320 - Y323	Y340 - Y343
	FP0R-E8YT / P FP0R-E8YR	Output (8 points)	Y300 - Y307	Y320 - Y327	Y340 - Y347
	FP0R-E16X	Input (16 points)	X300 - X30F	X320 - X32F	X340 - X34F
	FP0R-E16R FP0R-E16T / P	Input (8 points)	X300 - X307	X320 - X327	X340 - X347
		Output (8 points)	Y300 - Y307	Y320 - Y327	Y340 - Y347
	FP0R-E16YT / P	Output (16 points)	Y300 - Y30F	Y320 - Y32F	Y340 - Y34F
FP0R-E32T / P	Input (16 points)	X300 - X30F	X320 - X32F	X340 - X34F	
	Output (16 points)	Y300 - Y30F	Y320 - Y32F	Y340 - Y34F	
FP0 analog I/O unit	FP0-A21	Input (16 points) CH0	WX30 (X300-X30F)	WX32 (X320-X32F)	WX34 (X340-X34F)
		Input (16 points) CH1	WX31 (X310-X31F)	WX33 (X330-X33F)	WX35 (X350-X35F)
		Output (16 points)	WY30 (Y300-Y30F)	WY32 (Y320-Y32F)	WY34 (Y340-Y34F)
FP0 A / D converter unit FP0 thermocouple unit	FP0-A80 FP0-TC4 FP0-TC8	Input (16 points) CH0, 2, 4, 6	WX30 (X300-X30F)	WX32 (X320-X32F)	WX34 (X340-X34F)
		Input (16 points) CH1, 3, 5, 7	WX31 (X310-X31F)	WX33 (X330-X33F)	WX35 (X350-X35F)
FP0 D / A converter unit	FP0-A04V FP0-A04I	Input (16 points)	WX30 (X300-X30F)	WX32 (X320-X32F)	WX34 (X340-X34F)
		Output (16 points) CH0, 2	WY30 (Y300-Y30F)	WY32 (Y320-Y32F)	WY34 (Y340-Y34F)
		Output (16 points) CH1, 3	WY31 (Y310-Y31F)	WY33 (Y330-Y33F)	WY35 (Y350-Y35F)
FP0 I/O link unit	FP0-IOL	Input 32 points	X300 - X31F	X320 - X33F	X340 - X35F
		Output 32 points	Y300 - Y31F	Y320 - Y33F	Y340 - Y35F

(Note 1): The channel datum of FP0 A / D converter unit (FP0-A80), FP0 thermocouple unit (FP0-TC4 / FP0-TC8) and FP0 D / A converter unit (FP0-A04V / FP0-A04I) are shifted, read and wrote according to the user program including conversion data switching flags.

(Note 2): For FP0 CC-Link slave unit, please confirm it according to the appropriate manual (the starting address must be read).

4

Installation and Wiring

4.1 Installation

4.1.1 Installation Environment and Space

■ Installation environment

Please install and use it in the range of the general specifications.

- Ambient temperature: 0 - + 55°C
- Humidity: 10 - 95% RH (non-condensing at 25°C)
- Contamination level: 2
- Operating altitude: 2000 m or less
- Installation class: Class 1
- Overvoltage category: II or less
- Installation place: inside the control cabinet

Do not use it in the following environments.

- Locations subject to direct sunlight
- Places where sudden temperature changes may cause condensation
- Environments containing corrosive gases and flammable gases
- Places containing much dust, iron powder and salt, etc.
- Places and environments may be contaminated by dust, gasoline, thinner, and alcohol or other organic solvents or ammonia, sodium hydroxide and other strong alkaline substances.
- Facilities which may be directly affected by vibration or shock and places directly exposed to water splashes
- Near high voltage power lines, high voltage equipment, power lines, power equipment or amateur radio transmitting apparatus and equipment that may generate large switching impact current (must be at least 100 mm away)

■ Static electricity

- In order to prevent damage caused by static electricity, release static electricity from the body before operating.
- Do not directly touch the connector pins.

■ Heat dissipation considerations

- In order to facilitate heat dissipation, set the LED display section toward the upper left side.

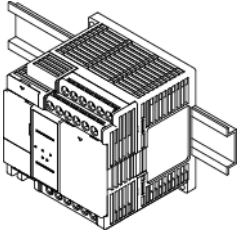

- Vertical, horizontal or upside down installation are prohibited because they will result in insufficient heat dissipation, leading to abnormal internal heat.
- Do not install directly above the heater, transformer, large capacity resistance and other equipment with large heat radiation.

■ Installation space

- To ensure ample ventilation space, please separate its upper and lower part and other equipment with the trunking etc. by 50 mm when installing.
- To avoid being affected by the radiation, the surface of each unit and the power line or electromagnetic switches should be separated by 100 mm or more when installing. Make sure it separated with other devices by a certain distance, especially when it is installed on the back side of the control cabinet.
- Please ensure space for the cable connecting to the programming tool.

4.2 Backup Battery Installation

4.2.1 Backup Battery Installation

- Please install the backup battery according to the following steps.

- Installation steps



◆ Steps

1. Open the operating unit cover and battery cover.
2. Insert the backup battery into the battery holder.
3. Connect the battery connector.
4. Close the operating unit cover and battery cover.

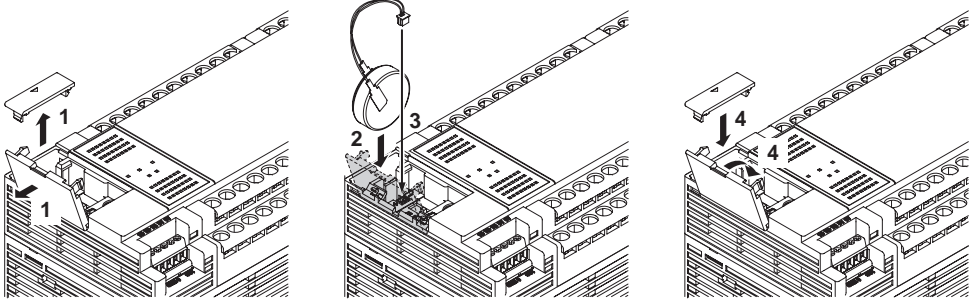

- When removing the backup battery, remove the unlocking portion.

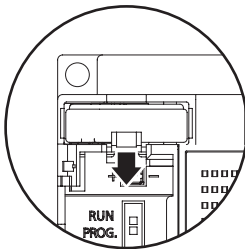

◆ Emphasis

- Backup battery is used for calendar clock function and the expansion of the backup area of the operational storage.
- As for the role of the backup battery, its battery life and setup of storage area, please refer to 6.1 Storage Backup.

4.3 Expansion Card Installation

4.3.1 Precautions for Installing Expansion Cards

- Use the supplied screws to fix the expansion card on the control unit.
- The screw tightening torque is 0.3 - 0.5 N m, please fasten it securely.

■ Recommended screws

Type	Size and other	Number
Self-tapping screw	Material: SW coil (+) P fasten 2.6-16 Zinc plated, trivalent chromate (black)	2/1 card



◆ CAUTION

- Make sure to turn off the power to install. Installing with the control unit is powered ON will cause failure.
- Do not touch the back of the expansion card and connector. IC may be damaged due to static electricity.

4.3.2 Communications Card Installation

The communication card can be installed on the control unit or function card.

■ Mounted on the control unit

- Connect the connector on the back of the communication card and the connector of the control unit card installation part, fix the communication card with screws at the bottom left and upper right.
- If the flange is retained, there shouldn't be any problem. AFPX-COM5 does not have flange.

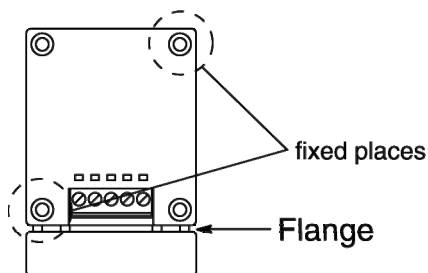
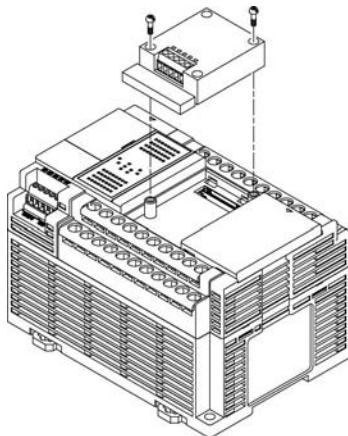

■ Mounted on the function card

- Connect the connector on the back of the function card and the connector of the control unit card installation part, fix the function card with screws at the bottom left and upper right.

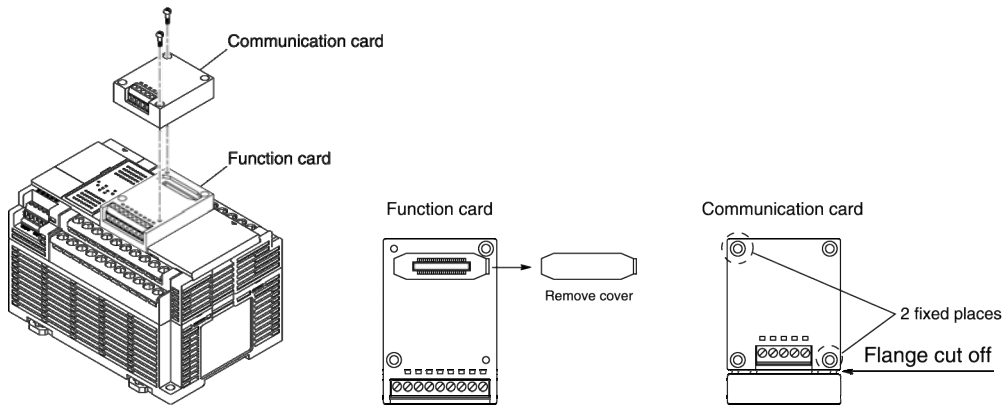

4.3.3 Function Card Installation

Function cards can only be installed on the control unit.

■ Mounted on the control unit

- Connect the connector on the back of the function card and the connector of the control unit card installation part, fix the function card with screws at the bottom left and upper right.

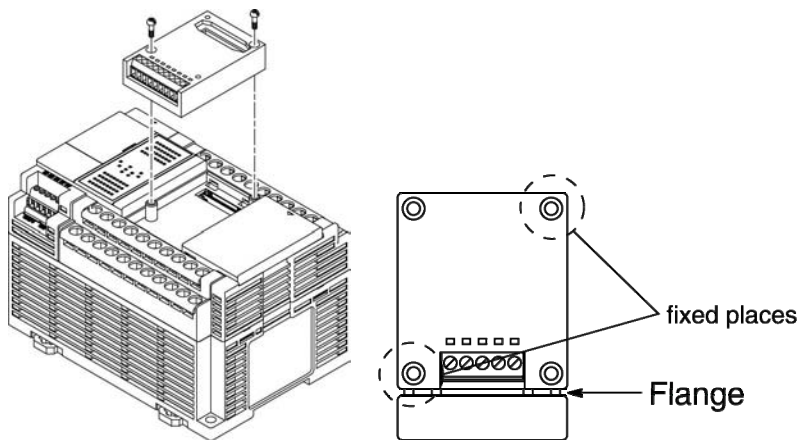

4.4 Connecting FP-X expansion unit

4.4.1 Setup of Terminal Setting Switches

- All switches of the expansion unit terminal setting DIP switch are set to ON.

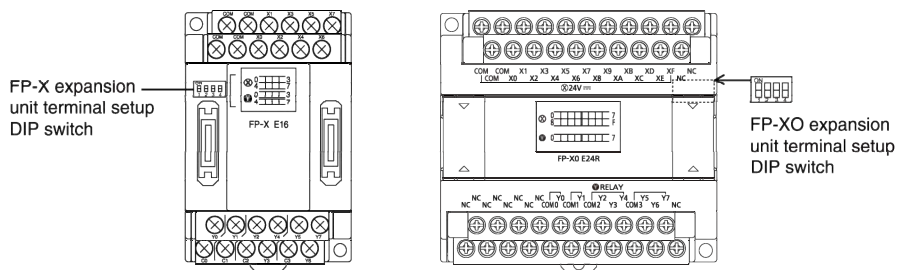

4.4.2 Confirmation of FP-X Expansion Cables

- FP-X expansion units and FP-X expansion FP0 adapters are connected to the control unit via a dedicated expansion cable.
- FP-X expansion units and FP-X expansion FP0 adapters come with an 8 cm type expansion cable (AFPX-EC08).
- When setting the unit on the upper and lower part, a long expansion cable must be used, please order 30 cm type (AFPX-EC30) or 80 cm type (AFPX-EC80) separately.



◆ CAUTION

- Please limit the total length of the expansion cable to less than 160 cm when using.
- Please try to keep the expansion cable (AFPX-EC30, EC80) away from interfering devices and wires.

4.4.3 Connecting FP-X expansion unit

Please connect FP-X expansion unit in accordance with the following procedure.

■ Installation steps



◆ Steps

1. Remove the control unit, the expansion unit expansion cover.
2. Install an expansion connector cable on the control unit expansion connector portion and expansion I/O unit expansion connector portion (left).

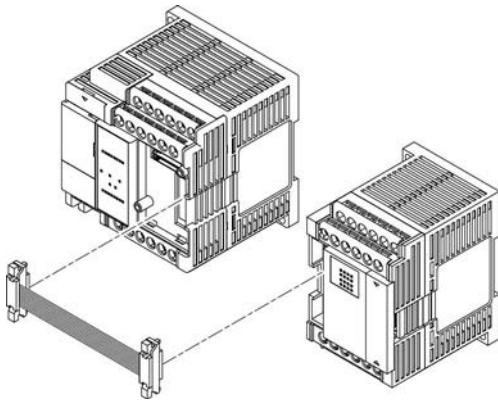

3. Units should be close together to ensure that the expansion cable is housed between the units.

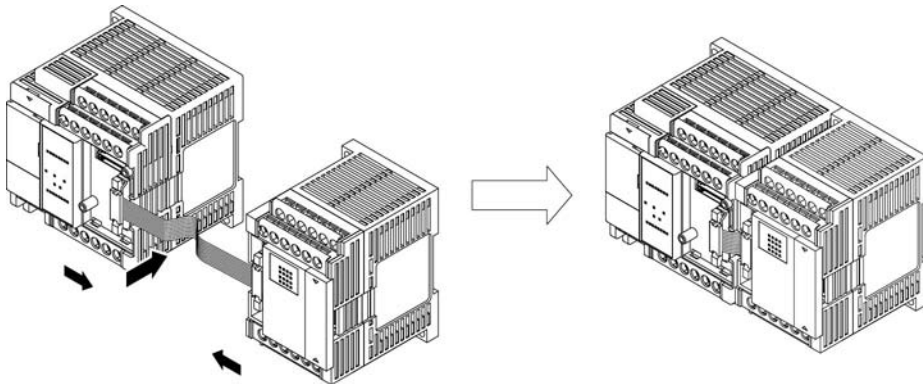

4. Install expansion cover.

4.5 Connecting FP0 Expansion Unit

4.5.1 Connecting FP0 Expansion Unit

- FP0 expansion units (expansion unit, high function unit) shall expand on the right side of FP-X expansion FP0 adapters.
- When the unit is expanded, use the FP0 right connector for expansion and the expansion hook on the side of the unit.

■ Installation steps



◆ Steps

1. Please use a screwdriver to move the expansion hook.
2. Install after the lug bosses on the expanded unit side are aligned.

Please make the connector tightly fitted to eliminate the gap between the units.

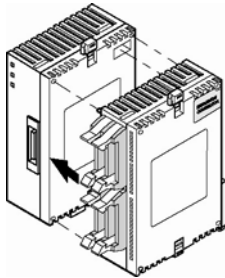

3. Please lift the expansion hook according to step 1 to fix the unit.

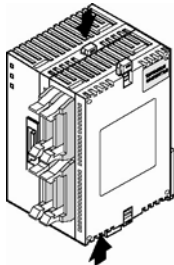

4.5.2 Connecting FP-X Expansion FP0 Adapter

Please connect FP-X expansion unit in accordance with the following procedure.

■ Installation steps



◆ Steps

1. Remove the control unit, the expansion unit expansion cover.
2. Install an expansion connector cable on the control unit expansion connector portion and FP-X expansion FP0 adapter expansion connector portion (left).

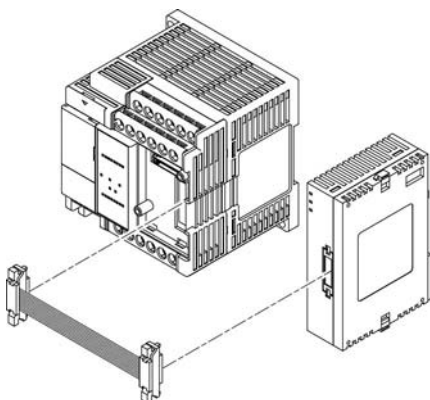

3. Units should be close together to ensure that the expansion cable is housed between the units.

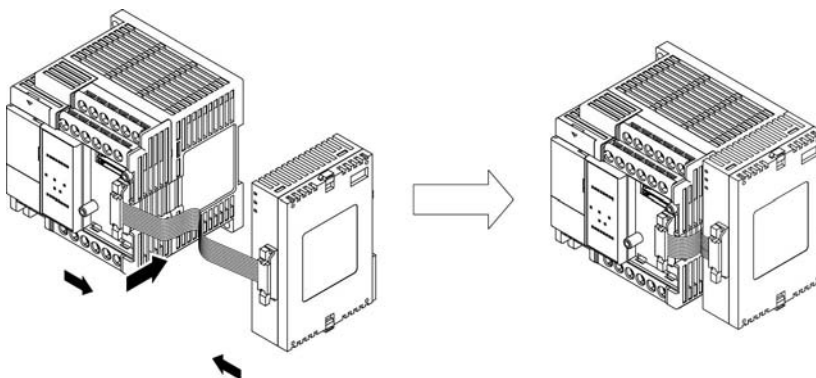

4. Install expansion cover.



◆ Emphasis

- The expansion FP0 adapter has no terminal setting switch, but the terminal is set inside it. Set the terminal setting switch of other expansion units to OFF.

4.6 Installation

4.6.1 Installation and Removal for DIN Rail

■ Installation steps



◆ Steps

1. Pull out all DIN rail mounting stems on the back of the unit from underside.
2. Embed the upper part of the unit installing part into the DIN rail.
3. Embed the lower part of the unit installing part into the DIN rail while pushing the unit installing part into the DIN rail.
4. Push up the DIN rail mounting stem on the back of the unit and lock until you hear a "click" sound.

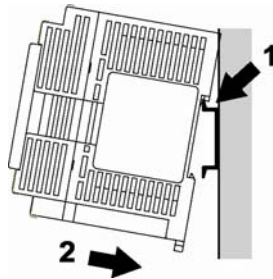

■ Removal steps



◆ Steps

1. Pull out all DIN rail mounting stems on the back of the unit from underside.
2. Pull the lower side of the unit toward you.
3. Remove it from the DIN rail while lifting the unit.

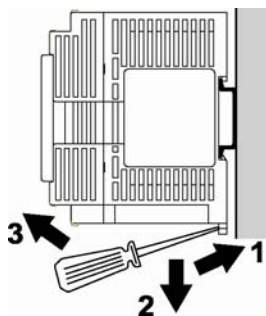

4.6.2 Mounting with Screws

Please use M4 screws for mounting.



◆ Reference

For installation dimensions, refer to 11.7.2 Dimensions.

4.7 Power Wiring

4.7.1 General Precautions

■ Power supply selection

- Please use a power supply with less interference whenever possible.
- Although overlap in the power line interference has sufficient interference tolerance, but we still recommend using the insulated transformer / insulated power supply for further interference attenuation.

■ Isolation of power system

Please separate wires for the unit, input and output device, and power equipment.

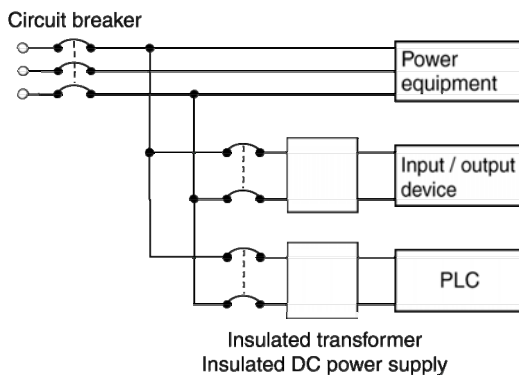

■ Power sequence

- Take the power sequence into consideration and cut off the PLC power supply before the power supply for input and output is shut off.
- If the input and output power is shut off before cutting off the PLC power supply, the control unit may sometimes detect the change of the input value and cause an unexpected sequence of actions.

4.7.2 Grounding

- To obtain adequate anti-interference performance, please make sure the power supply is grounded.
- Grounding location shall be as close as possible to the PLC to shorten the length of the grounding wire.
- When used in common with other devices, it can sometimes lead to an opposite effect, so dedicated grounding must be used.
- For grounding terminal of the AC power supply unit, carry out the grounding with a grounding resistance at 100Ω or lower.

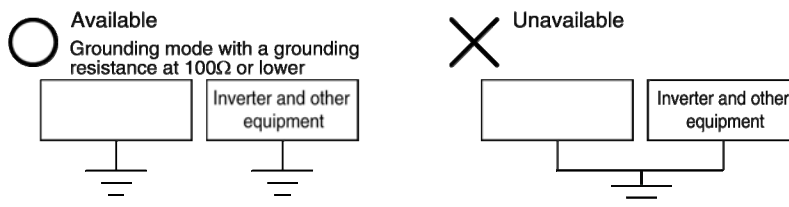

4.7.3 Power Supply of Control Unit / Expansion Unit

■ Power wiring (FP-XH control unit and FP-X expansion unit)

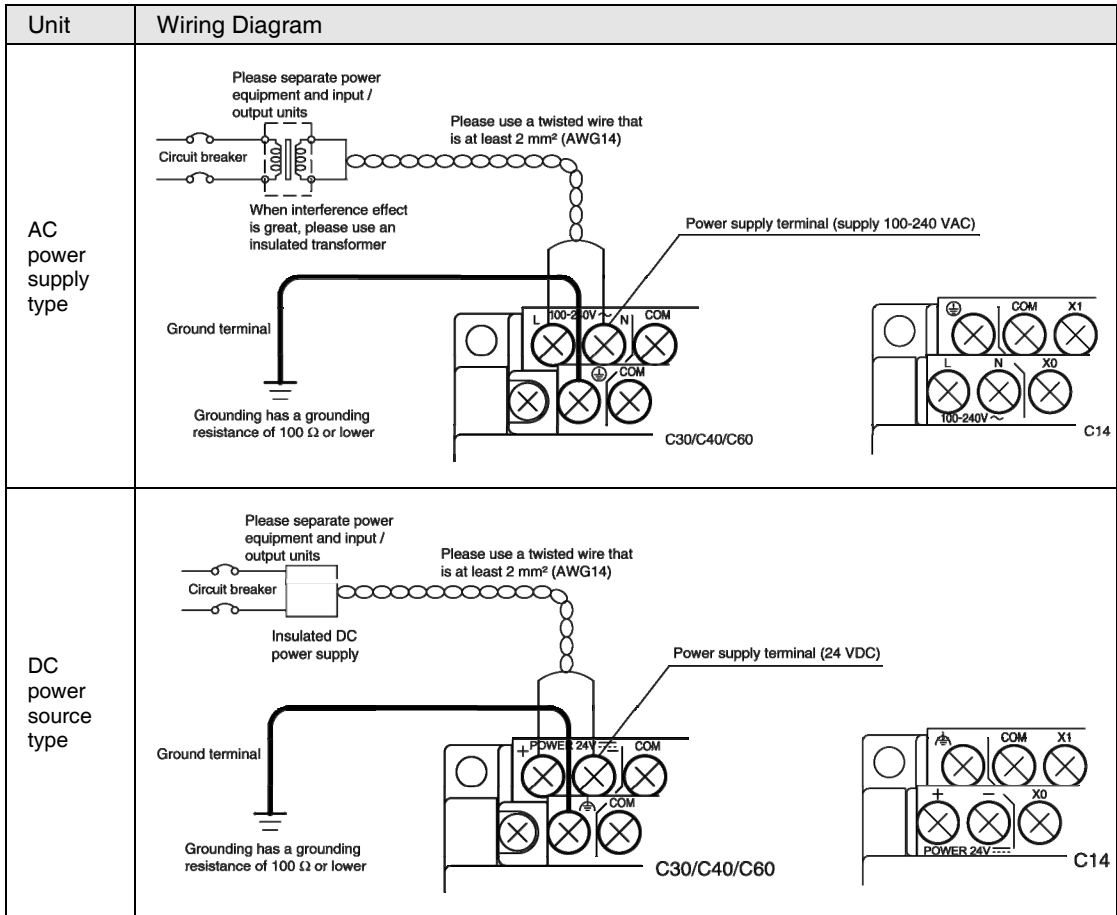

■ Supply voltage

Please confirm that the voltage of the power supply to be connected is within the allowed range.

Model	Rated input voltage	Allowable voltage range	Rated frequency	Allowable frequency range
AC Power Supply Type	100 - 240 VAC	85 - 264 VAC	50 / 60 Hz	47 - 63 Hz
DC Power Supply Type	24 VDC	20.4 - 28.8 VDC	—	—



◆ CAUTION

- For C14 and C30 / C40 / C60, the location of the power supply terminal is different.

■ Power supply cables

- To reduce the voltage drop, use a wire that is at least 2 mm² (AWG14).
- To reduce the influence of interference, the power cable shall be stranded (strand processing).

■ Applicable wires

Applicable wires	Tightening torque
AWG22-14 (0.3 mm ² -2.0 mm ²)	0.5 - 0.6 N m

■ Applicable crimp terminals

M3 terminal screws are used for the terminals. Please use the following crimp terminals to connect terminals.

Fork type terminal

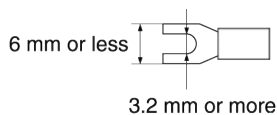

Ring type terminal

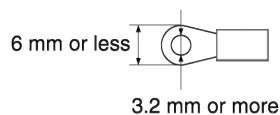

■ Applicable crimp terminals

Shape	Model	Applicable wires
Round	2-MS3	1.04-2.63 mm ²
Fork type	2-N3A	

(Note) Use a wire that is at least 2 mm².



◆ CAUTION

- If the voltage or frequency of the power supply exceeds the allowable range, or a wire outside the specified range is used, the power unit of the PLC may fail.

4.7.4 Power Supply of FP-X Expansion FP0 Adapter / FP0 Expansion Unit

■ Power wiring (FP-X expansion FP0 adapter / FP0 expansion unit)

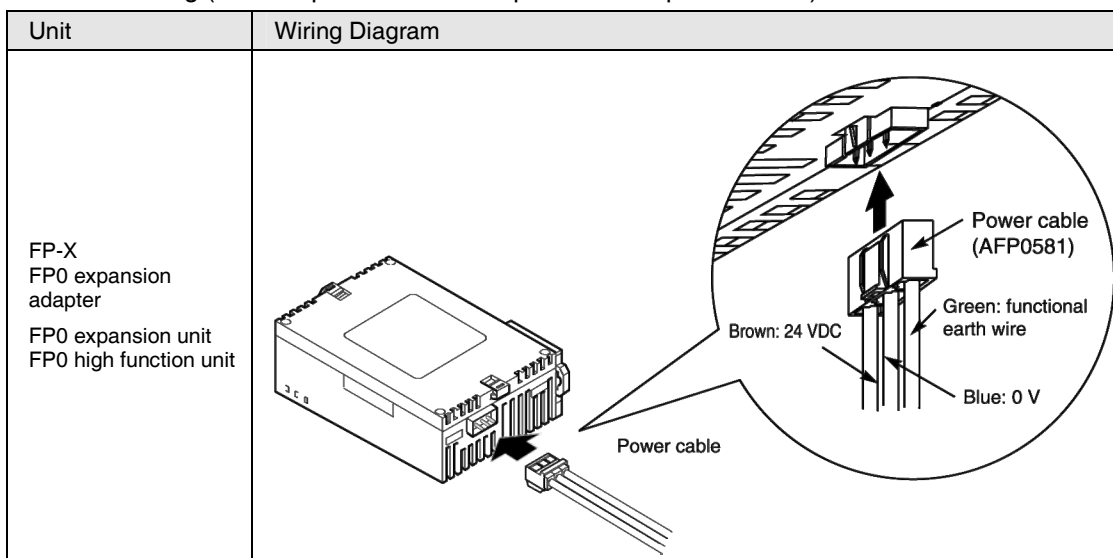

■ About power supply selection

- To prevent against the abnormal voltage from the power line, use a insulated power with built-in protection circuit (reinforced insulation or double insulation wire).
- The built-in regulator of the unit uses a non-insulated type.
- In order to simultaneously start the power supply, the power of the expansion FP0 adapter shall be supplied by a universal power supply for FP-XH control unit input.

■ Supply voltage

- Please confirm that the voltage of the power supply to be connected is within the allowed range.

Rated input voltage	Allowable voltage range
24 VDC	20.4 - 28.8 VDC

■ Power supply cables

- Use the supplied power cable (model: AFP0581) to connect the power supply.
Brown: 24 VDC Blue: 0 V Green: functional earth wire
- To reduce the influence of interference, the power cable shall be stranded (strand processing).

■ Power sequence

- In order to effectively and easily achieve the expansion FP0 adapter power sequence, the power of the expansion FP0 adapter shall be supplied by a universal power supply for FP-XH input.
- Power on the FP0 expansion unit before turning on the FP-X system power.
- Note the power sequence, the power of the FP-X system and the FP0 expansion unit shall be turned off before the input and output power is switched off. If the input and output power is shut off first, the control unit may sometimes detect the change of the input value and cause an unexpected sequence of actions.

Operation	Power sequence
ON	FP0 power → FP-X power, expansion FP0 adapter → input and output power
OFF	FP-X power, expansion FP0 adapter → FP0 power → input and output power

■ Grounding of the FP-X expansion FP0 adapter and FP0 expansion unit

- The functional grounding wire (green) of the included cable shall be grounded. Depending on the different service environments, sometimes there will be problems if grounded.
- The power line of the FP-X expansion FP0 adapter connects to the functional grounding through a varistor. The varistor may be shorted when there is an abnormal potential between the power line and the ground.

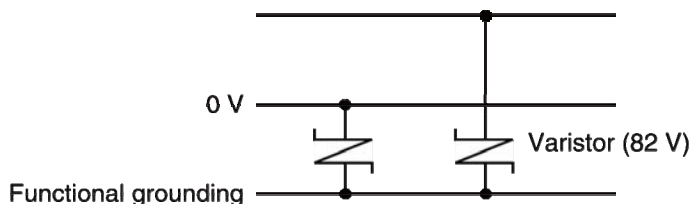

Extended FP0 adapter power circuit

4.8 Input and Output Wiring

4.8.1 Common Considerations for Input and Output

■ Wiring location

The input wire, output wire and power line shall be separated from each other, try to keep their distance when wiring. Don't put them in the same conduit or tie them up. The input wire, output wire, power line and high-voltage line shall be separated by at least 100 mm.

■ Wire selection

When wiring the input line and output line, select the wire diameter according to the current capacity.

■ Power supply

Switch off the PLC power supply before wiring. The control units, expansion units and all cards shall be connected with the power supply switched off. If you make the connection with the power supply switched on, a failure or malfunction may occur.

4.8.2 Universal Power for Input and Output (Control Unit and Expansion Unit E30)

■ Uses of the universal power for input

- Please use it for the input circuit and expansion FP0 adapter.
- For the power of the FP0 expansion unit, use an external power supply.
- For other devices, make the connection after the consumption current of the device is fully recognized.
- If overcurrent condition is continued for a prolonged time, it may cause damage to the power supply.

4.8.3 Wiring of the Input Side

- Connection with photoelectric sensors and proximity sensors

Relay Output Type

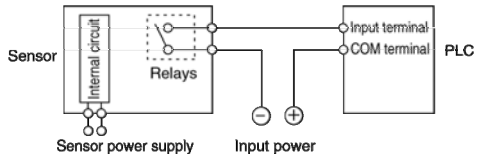

NPN Open Collector Output Type

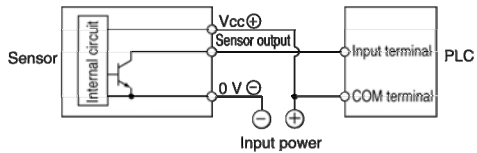

Voltage Output Type

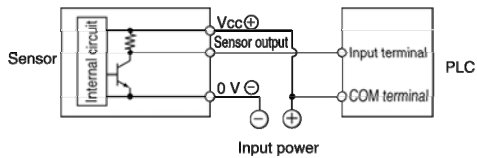

Two-Wire Output Type

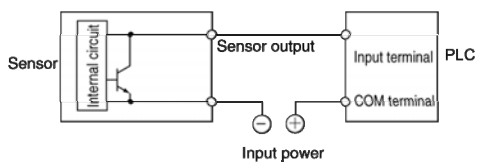

■ Precautions when using a reed switch with LED

If the LED is connected in series to the input contacts (such as a reed switch with LED, etc.), apply a voltage greater than the ON voltage to the input terminal of the PLC. Please pay special attention when several switches are connected in series.

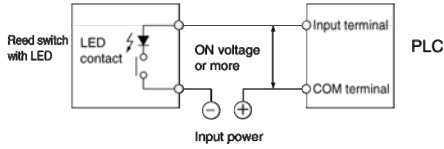

■ Precautions when using a two-wire sensor

When using a two-wire photoelectric sensor or proximity sensor, if cutting off the input current flowing to PLC is not possible due to the leakage current, connect the bleeder resistor as shown in the left chart.

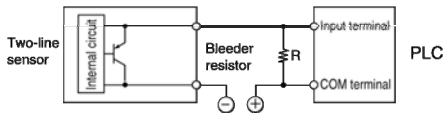

■ Precautions when using a limit switch with LED

When using a limit switch with LED, if cutting off the input current flowing to PLC is not possible due to the leakage current, connect the bleeder resistor as shown in the left chart.

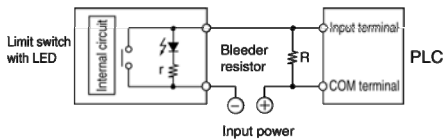

4.8.4 Wiring of the Output Side

■ Protection circuit of the inductive load

For inductive load, please install a protection circuit parallel with the load. When the DC inductive load is switched on/off, the protection circuit has a great positive influence on the service life, particularly for the relay output type. Therefore, make sure the diode is connected at both ends of the load.

For AC load

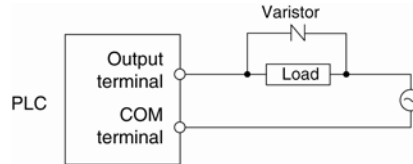
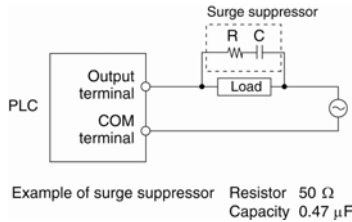

For DC load

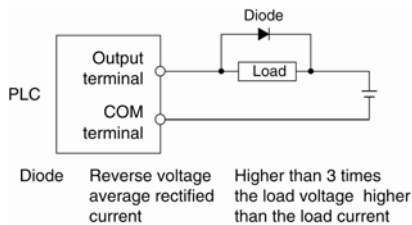

■ Precautions on using capacitive loads

When connecting a load with a large impact current, please set up the protection circuit as the following figure to minimize its impact.

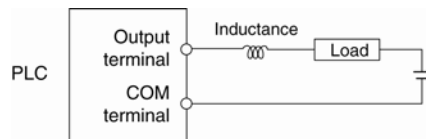
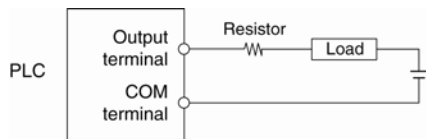

4.9 Terminal Block Wiring

4.9.1 Applicable wires

■ Applicable wires

Applicable wires	Tightening torque
AWG22-14 (0.3 mm ² -2.0 mm ²)	0.5 - 0.6 N m

■ Applicable crimp terminals

- M3 terminal screws are used for the terminals. Please use the following crimp terminals to connect terminals.
- When using round terminals, remove the terminal block cover before operating.

Fork type terminal

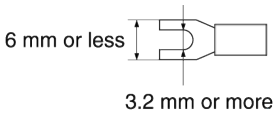

Ring type terminal

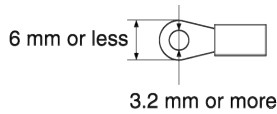

4.9.2 Terminal Block Cover

- When using round terminals, remove the terminal block cover before operating.

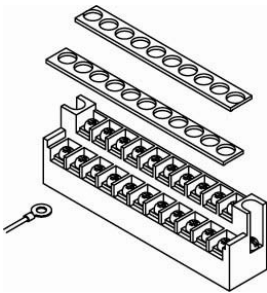

◆ CAUTION

- To prevent electric shock, make sure to install the terminal block outer cover as is after wiring.

4.9.3 Removal and Installation of the Terminal Block (C30 / C40 / C60)

The terminals used by C30 / C40 / C60 are installed with screws, so they can be removed.

■ Removal of the terminal block

Loosen the 2 mounting screws to remove the terminal block. The screws are fixed on the terminal block, they can not be removed.

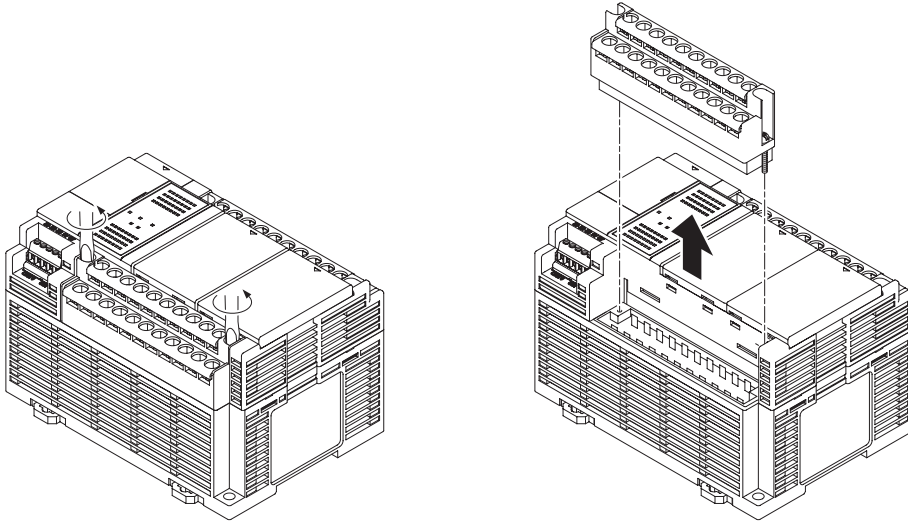

■ Installation of the terminal block

- Tighten the screws when the terminal block is lifted up. After tightening the screws, the terminal box is fixed.
- Please set tightening torque to 0.25 - 0.35 N m.

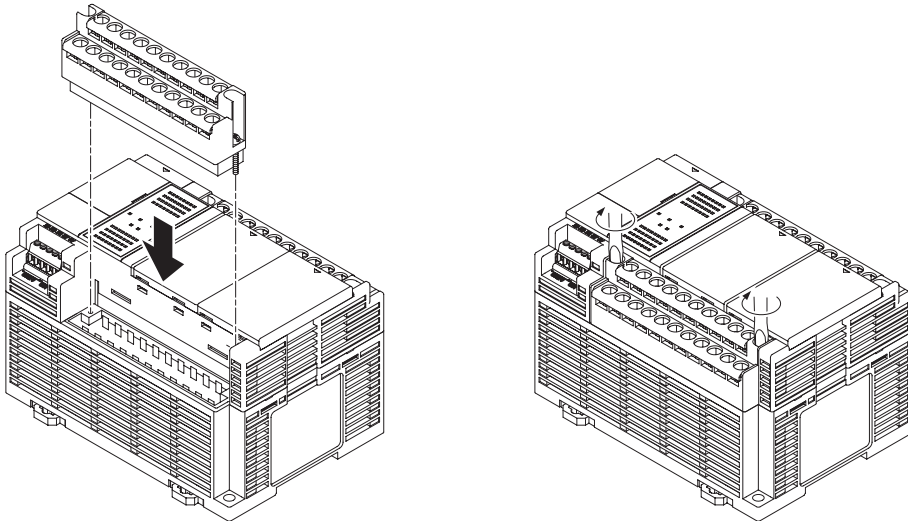

4.10 Safety Measures

4.10.1 Safety Measures

■ Precautions on system design

- In a system using PLC, a malfunction may occur due to the following causes.
 - The start and stop time between the PLC power supply and the input / output device and power equipment are inconsistent.
 - Response time deviation caused by momentary power failure.
 - PLC unit, external power supplies and other devices are abnormal.

Take safety measures to prevent the entire system from anomalies or accidents caused by this malfunction.

■ Setting of the interlock circuit

- Set the interlock circuit outside the PLC when controlling forward, reverse and other operations of the motor.

■ Setting of the emergency stop circuit

- In an emergency, the circuit to cut off the power supply of the output device shall be set up outside of the PLC.

■ Power sequence

- Start the PLC after the input and output device and power equipment are started.
- When stopping the PLC, please also stop running the PLC before stopping input and output devices and power equipment.

■ Grounding

- When installing PLC near the device that will generate high voltage due to the switching action of inverters, etc., common grounding shall be avoided. Please use at least a dedicated grounding of D type grounding (third grounding).

■ Electric shock prevention

- Do not forget to install the terminal cover after wiring.

4.10.2 Temporal Outage

- Actions during temporal outage
- If the temporal outage time is shorter than 10 ms, the FP-XH control unit will continue to operate. When it exceeds 10 ms, the action of the control unit will be changed according to the conditions such as combination of the unit and the supply voltage. Sometimes the same action as the power supply reset will generate.
- Although the temporal outage time of the expansion FP0 adapter is 10 ms, please determine the allowable time of the system after confirming the allowable temporal outage time of the DC power supplying power to the expansion FP0 adapter. In addition, the power of the FP-X expansion FP0 adapter shall be supplied by a universal power supply for FP-X control unit input.
- When using the expansion unit including other power (E30, expansion FP0 adapter), according to the temporal outage time, sometimes only one of the units will experience temporal outage and I/O checking error. In this case, reconnect the power supply.

4.10.3 Watchdog Timer

- The watchdog timer detects abnormal program or hardware.
- When using the FP-XH control unit, it is set to 640 ms.
- The ERR LED at the front of the controller unit lights up after the watchdog timer is operated. At this time, the output of all output units turned to OFF and brought to a standstill.

5

Steps Before Running

5.1 Before Turning on the Power

5.1.1 Check Items

After wiring, check the following items before turning on the power.

■ Check Items

	Item	Contents
1	Unit mounting	<ul style="list-style-type: none">● The name of each unit matches the device list as designed.● Mounting screws on the unit are securely tightened. No looseness.
2	Wiring	<ul style="list-style-type: none">● The terminal screws are securely tightened and with no looseness.● Wiring and signal names of the terminals are consistent.● Wire specifications fully fit the current size.
3	Cable connection	<ul style="list-style-type: none">● Cables are securely connected?
4	Mode setting	<ul style="list-style-type: none">● The mode toggle switch is set to "PROG." mode.
5	Others	<ul style="list-style-type: none">● Please carefully confirm the possibility of accidents.

5.1.2 Steps Before Running

For configuration after wiring, the steps before running are as follows.

1. Power ON

- (1) Before switching on the power, refer to "5.1.1 Check Items" to check.
- (2) After switching on the power of the control unit, please confirm that the control unit's PROG. LED (green) is lit.



2. Input the program

- (1) Use the tool software to create a program.
- (2) Use the "Overall Check Function" of the tool software to check for syntax errors.



3. Confirm the output wiring

Use the mandatory input / output function etc. to check the output wiring.



4. Confirm the input wiring

Check the input wiring through the input display LED or the monitoring function of the tool software.



5. Test run

- (1) Set the mode toggle switch to "RUN" mode, confirm that the "RUN" LED is lit.
- (2) Confirm the serial actions.



6. Commissioning

- (1) When there is an abnormal action, use the monitoring function of the tool software to confirm the program's abnormality.
- (2) Modify the program.



7. Save the program

Save the program created.

5.2 Offline Editing of the Program

5.2.1 Program Elements

Create the following items as program data according to the following steps.

■ Program composition

Type	Contents
Program	Any program
Comments	Maximum 2 MB I/O comments, description, comments between the lines
System register	Set the holding area using the operational storage, the operation mode during an abnormality, communications, high-speed counter and the allocation when using pulse output function.
Position control parameter Position control data sheet data	When using the pulse output function through the data sheet setting mode, please set via the Configurator PMX. Position control parameters have been set and the position control data sheet data are saved as part of the program file. You can export or import it via the Configurator PMX, and save only the position control related data as other file.

5.2.2 Settings of the System Register

Follow these steps to set the system register. Explain it as belows assuming that the FPWIN GR has been started.



◆ Steps

- 1 In the menu bar, select "Option" → "PLC System Register Setting".

The "PLC System Register Setting" dialog box displays.

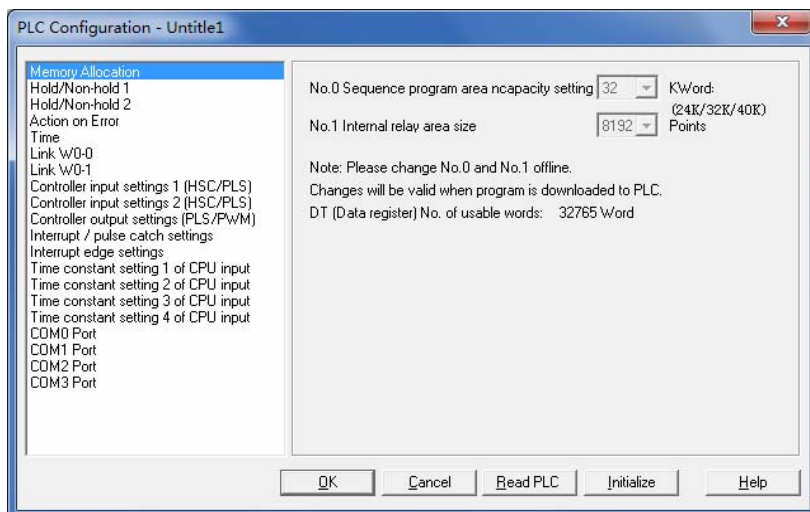

2. Select any item to set.

3. Press the [OK] button.

The contents have been set are saved as part of the program.

■ Type of system registers

Type	Contents
Memory allocation	Set when changing program capacity and internal relay points.
Hold / non-hold	Set when changing holding areas of internal relays, data registers and other operational storages. To ensure these settings are effect, you must install the memory backup battery (sold separately).
Operate during abnormality	Select the operating mode used when an operation error occurs. In addition, the abnormality warning function shall be set as active when installing memory backup battery.
Time setting	Set the timeout time when using the communication function and the time for constant scanning.
PC link W0 setting	Allocate the station number and the link area when using the inter-PLC link function.
Controller input settings (HSC / PLS / PWM)	Allocate the input and output signal and channel when using the function of HSC (High SpeedCounter), PLS (Pulse Output) and PWM (PWM Output).
Interruption and pulse catch setting	Specify the inputs allocated when using interrupt input or pulse catch input. When the input is interrupted, an effective pulse edge can be selected.
Interrupt pulse edge setting	
Constant setting for controller input	Assign a input for filter constant when the input is set as active.
COM port setting	Set the station number and communication speed, transmission format and other communication parameters via the COM port when using the communication function.



◆ Emphasis

- Set the system register when using functions and changing the holding area from default state. There is no need to set when the appropriate function is not in use.

5.2.3 Setting of Position Control Parameters

When using the pulse output function through the data sheet setting mode, please set via the Configurator PMX. Start the Configurator PMX from the "Options" menu of FPWIN GR.



◆ Reference

- For details on the system register, refer to 11.3 System Register List.
- For pulse output functions based on data sheet setting mode and operations of the Configurator PMX, refer to FP-XH User Manual (Position Control / PWM Output Function).

5.3 Program Download and Run

5.3.1 Before Turning on the Power

Before turning on the power, verify the mode toggle switch of the control unit. According to the different states when the power is on, the behavior will change as following.

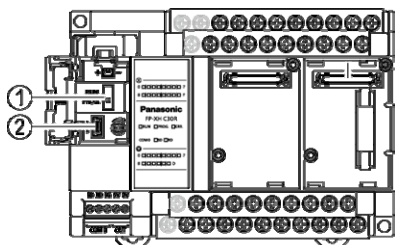

①	Mode toggle switch	②	USB port
---	--------------------	---	----------

■ Difference between mode behaviors

Type	Contents
When the power is turned on in the PROG. mode	<ul style="list-style-type: none"> ● When the power is turned on, show as the state of data saved in the control unit controller and computer (program, comments, system register data, data register). ● Through the operation of the tool software, it can change to status: computer → download to the control unit controller, or control unit → upload to your computer. ● If the program and other required data are not written in the control unit controller, turn on the power via PROG. mode.
When the power is turned on in the RUN mode	<ul style="list-style-type: none"> ● When the power is turned on, transmit the datum saved in the control unit controller's built-in memory (F-ROM) to the control unit Controller memory, then start running. ● When the program and other required data have been saved, turn on the power via RUN mode when running.

■ Mode switch based on the tool software

- If it is online after the power is on, the operation mode can be switched by the tool software. However, when the power is turned on again after the power is turned off, run in the the mode selected by the mode toggle switch.

■ Connection of the computer and control unit

- The USB port of the control unit is connected to the computer. Use USB 2.0 cable (A: mini B) when connecting

5.3.2 Overall Program Check

- Before you download the program, perform a overall check to verify if there is a syntax error.
- You can check for dual use of the coil and match instruction (MC and MCE, JP and LBL, SUB and RET, etc.) defects.



◆ Steps

1. Select "Debug" → "Overall Check" from the menu bar.

The overall check dialog box displays.

2. Click the [Run] Button.

The check result displays. When there is an error, click the "Jump" button to jump to the appropriate location.

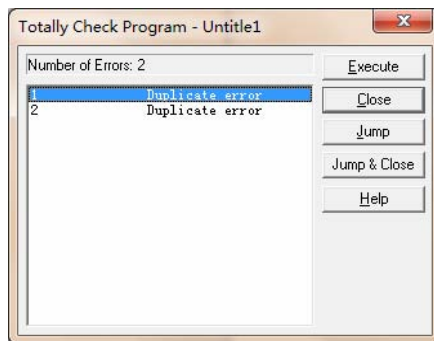

5.3.3 Program Downloading and Mode Switching

- Programs created by the tool software can be downloaded to the control unit controller.
- The downloaded program are saved to the program memory (F-ROM). It can be saved even in case of power outage.

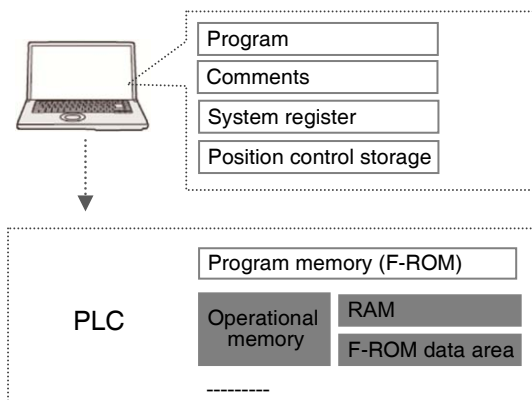

■ Download steps

Use the following steps to download the program data. Explain it as belows assuming that the FPWIN GR has been started.



◆ Steps

1. Select "Online" → "Online Editing" from the menu bar.
2. Select "File" → "Download to PLC" from the menu bar.

The confirmation dialog box displays.

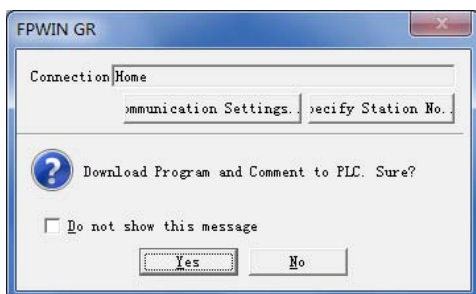

3. Click the [Yes] button.

Start downloading, and the status bar displays "Program in the step xx has been downloaded" message. In addition, the information dialog box for confirming whether to switch the mode displays.

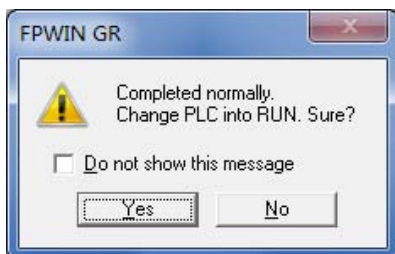

4. Click [Yes] or [No] button.

Click "Yes" to switch to RUN mode. Click "No" to switch to monitoring mode.



◆ Emphasis

- When you switch to RUN mode, operate it after confirming that there will be no danger even the PLC is in motion.
- When you switch to RUN mode, the ERR LED lights up after an error occurs, and then return to PROG. mode. Please refer to 9.2 Troubleshooting Exceptions.

■ When "MEWNET device open circuit error" appears

Follow these steps to clear the error status.



◆ Steps

1. Verify that the power of the control unit is switched on.
2. Verify that the computer and the control unit are connected via a USB cable.
3. Select "Options" → "Communication Setting" from the menu bar.

The "Communication Setting" dialog displays.

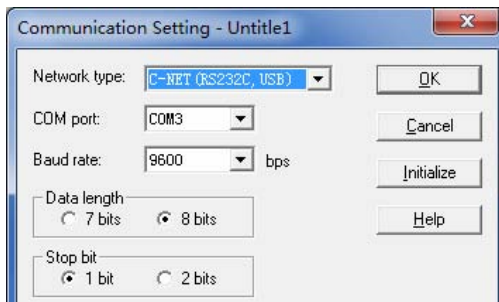

4. Confirm the port number and click [OK] button.

Make sure the computer and the control unit can communicate.



◆ Emphasis

- Port No. can be confirmed through the computer's device manager.

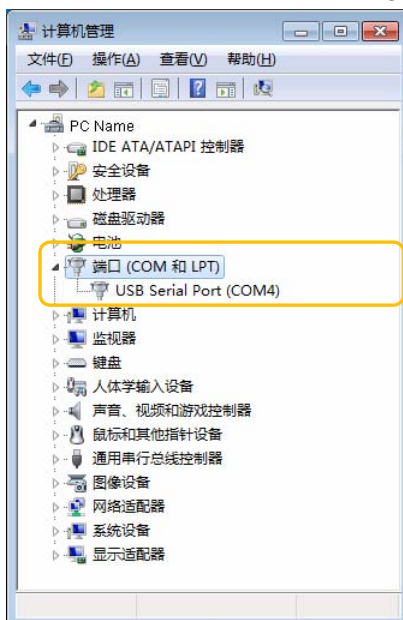

5.3.4 Program Check

To confirm that the program being edited on the computer is the same as that on the control unit controller, check it when necessary. Explain it as belows assuming that the FPWIN GR has been started.



◆ Steps

1. Select "Online" → "Online Editing" from the menu bar.
2. Select "Debug" → "Program Check" from the menu bar.
The Program Check dialog box displays.
3. Click the [Run] Button.

Start checking, and the result displays. Shows as below if not consistent. Click the "Details" button to display corresponding addresses.

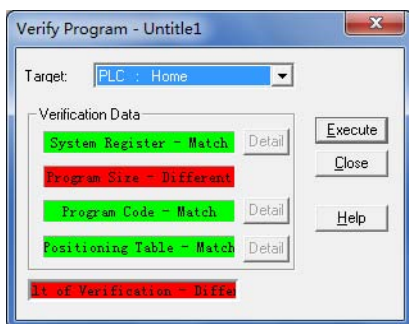

■ Check result

Check contents	Example in case of inconsistency
System register	Shows inconsistent error when the setting contents of the system register are not consistent.
Program size	Recognize as inconsistent error when the program size and code are different.
Program code	When the program code is consistent, contact, coil number, and operands may be inconsistent.
Position control data sheet	Recognize as inconsistent error when the position control parameters and position control data sheet are different. When the system register is inconsistent, axis parameters may also be inconsistent.



◆ Emphasis

- When switching from offline to online, if the program and system register are inconsistent, the message box showing the content displays.

5.4 Online Editing

5.4.1 Online Editing Summary

In the FP-XH control unit, even if the computer and the PLC are connected online, it can also be edited using the following conditions.

■ Online Editing

Type	Mode		Emphasis
	PROG	RUN	
Program	Possible	Possible	<ul style="list-style-type: none"> ● For pixel input mode, up to 512 steps can be rewritten. ● To ensure the compatibility of the program, rewriting in RUN mode is conditional. ● You can download the program and all comments even in RUN mode.
Comments	Unavailable	Unavailable	<ul style="list-style-type: none"> ● Online rewriting is not available. You must download all programs. ● You can download the program and all comments even in RUN mode.
System register	Possible	Unavailable	<ul style="list-style-type: none"> ● Rewriting is only possible in PROG. mode. To rewrite in RUN mode, it will show a confirmation message box to switch to PROG. mode.
Position control data	Unavailable	Unavailable	<ul style="list-style-type: none"> ● Online rewriting is not available. You are required to edit offline and download all programs.

(Note 1): In case of online editing, although the entered comments show, you can not save them to the memory of the control unit.

5.4.2 Online Editing of the Program

 Warning	When changing the program during operation, make sure it is safe before changing.
--	--

■ Online Editing of the Program

You can execute online editing of the program in PROG. mode or RUN mode.



◆ Reference

- For details and restrictions on rewriting during RUN, refer to FP-X User Manual (No.ARCT1F409C).

■ Block rewrite steps

You can change the program in PROG. mode or RUN mode. The following is a description of the contents being edited online by GR FPWIN.



◆ Steps

1. After changing any program, press <Ctrl> button + <F1> button to perform PG conversion.

The confirmation dialog box displays.

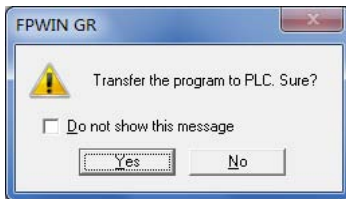

2. Click the [Yes] button.

The "Block comments display abnormal warning" dialog box displays.



3. Click the [Yes] button.

At the end of the normal conversion, the information displays in the status bar.



◆ Emphasis

- The block comment is connected with the Boolean address of the program and managed within the PLC. When changing the program online, download the program to match the position of the block comment. In addition, confirm the position of the block comment address via the FPWIN GR block comment list dialog box.

5.4.3 Online Editing of the System Register

Changing the system register is only possible in PROG. mode. The following is a description of the contents being edited online by GR FPWIN.



◆ Steps

- 1 In the menu bar, select "Option"→"PLC System Register Setting".

The "PLC System Register Setting" dialog box displays.

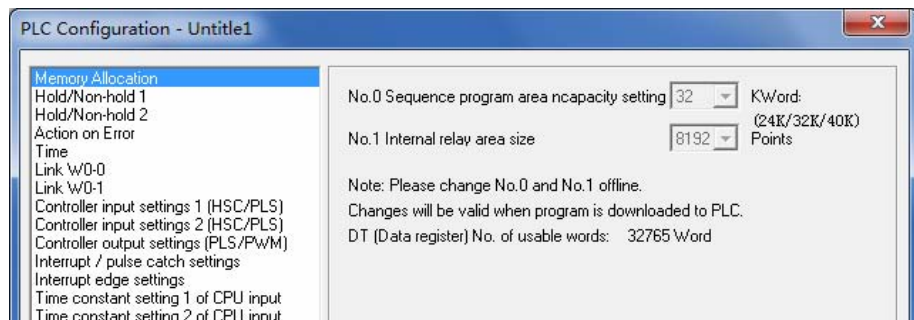

2. Change any system register and click [OK] button.

The confirmation dialog box displays.

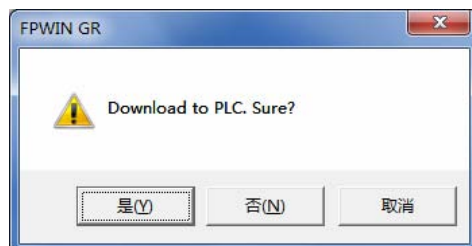

3. Click the [Yes] button.

The information indicating system register writing is completed shows in the PLC.

5.4.4 Download Function in RUN Mode



Warning

When changing the program during operation, make sure it is safe before changing.

In RUN mode, you also can download all programs and comments. Downloading in RUN mode can be performed according to the following steps. The following is a description of the online contents in the FPWIN GR.



◆ Steps

1. Select "File" → "Download to PLC" from the menu bar.

A confirmation message box appears.



2. Click the [Yes] button.

A message box to determine the download method in RUN mode displays.



3. Select the download method, click [OK] button.

Perform the download.

■ Download method in RUN mode

Method	Emphasis
Download the program in RUN mode	Download the program and comments. Do not download system register and position control data.
Switch to PROG. mode to download programs and system registers.	Download programs, comments, system registers and position control data.

6

Memory / Main Memory Card

6.1 Storage Backup

6.1.1 Program Memory Backup

The contents downloaded to the control unit controller can be saved even in case of power outage.

■ Program Memory Backup

Type	Remarks
Program	
Comments	Maximum 2MB I/O comments, description, comments between the lines
System register	
Position control data	Contains position control parameters and position control data sheet data set by the Configurator PMX.

6.1.2 Operational Memory Backup

- The operational memory includes outage hold and non-hold area.
- In the FP-XH control unit, backup fixed area in case of a power outage or mode switching (RUN → PROG.).

■ Non-hold and hold area

Type	Description
Non-hold area	In case of a power outage or mode switching (RUN → PROG.), the data content is reset to 0.
Hold area	In case of a power outage or mode switching (RUN → PROG.), maintain the previous operational data.

■ Automatic backup in case of an outage

Type	Hold Area	
Counter	16 points	C1008 - C1023
Counter elapsed value area	16 words	EV1008 - EV1023 (note 1)
Internal relay	128 points	R5040 - R511F or R2480 - R255F (note 2)
Data register	315 words	C14 DT11970 - DT12284
		C30 / C40 / C60 (note 3) DT11970 - DT12284 (When 40k step program capacity is selected) DT32450 - DT32764 (When 32k step program capacity is selected) DT65218 - DT65532 (When 12k step program capacity is selected)

(Note 1): You can not hold counter target value area SV.

(Note 2): The internal relay range varies from the system register No.2 internal relay capacity setting.

(Note 3): For C30 / C40 / C60, the data register range varies from the system register No.1 internal relay capacity setting.

■ Backup based on user program P13 (ICWT) instruction

Type	Description
How to use	The user program allows you to write P13 (ICWT) instruction and transfer the data register to the F-ROM area. Specifies the continuous range for using the 2K character as 1 storage block. Read from the F-ROM area to the data register by F12 (ICRD) instruction.
Write numbers	Less than 10 thousand times

6.1.3 Operational Memory Backup (When Battery Installed)

- Initially, install the backup battery sold separately when the hold area is insufficient or using the calendar clock function.
- After installing the battery, all the following areas also can be backed up in case of a power outage or mode switching (RUN → PROG.).

■ Backup using a backup battery

Type		Hold Area	
Operational memory	Timer	The tool software allows you to set the system register No. 6 - No.13 and specify any hold / non-hold area. (You can also keep the whole point)	
	Timer elapsed value area		
	Internal relay		
	Data register		
	Step ladder diagram		
	Link relay		
	Link register		
Special data register	Calendar clock	Monitoring area	DT90053: hour/min (read only)
		Setting and monitoring area	DT90054: min/sec, DT90055: day/hour, DT90056: year/month, DT90057: week

(Note 1): If detects that the battery is running out when the power is on, the operational memory of the hold area will be cleared to 0.

■ Backup battery type (sold separately)

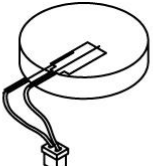
Appearance	Product Name	Specification	Order Number
	Backup battery for FP-XH	With connector	AFPXHBATT

(Note): You can not use the old model FP-X series battery.

■ Number of installed batteries

For FP-XH, only one battery can be installed.



◆ Reference

For battery installation methods, refer to 4.2 Backup Battery Installation.

6.1.4 Alarm Battery Error / Setting of the Hold Area

■ Setting of alarm battery error

- If a backup battery installed, select the "System Register No. 4 Alarm Battery Error" check box.
- When the battery capacity is low, the ERR.LED of the control unit controller lights and an error alarm occurs.

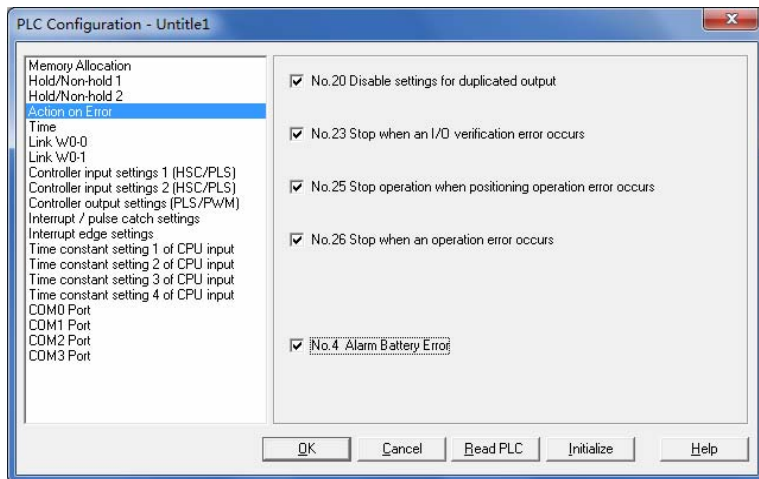

■ Setting of the hold / non-hold area

When changing the range of the hold area of data registers and other operational memory areas, set the system register No. 6 - No. 14.

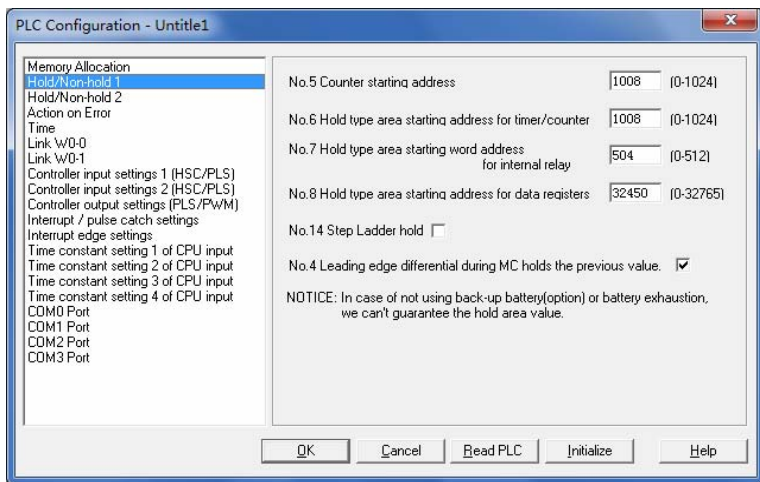

◆ Emphasis

- If the "Alarm Battery Error" is not set, the ERR.LED will not blink even if a battery error is detected.
- The setting of the system register No. 6 - No. 14 are only effective when the backup battery is installed. Use the initial values directly when the battery is not installed.

6.2 RAM / ROM Transfer Function

6.2.1 Function Outline

Through an operation based on the tool software, the contents of the hold area of the data register DT can be backed up to the F-ROM area of the control unit built-in memory.

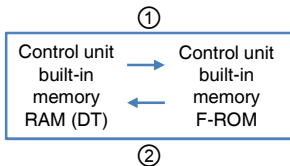

6.2.2 Operations Using the Tool Software

Explain it as belows assuming that the FPWIN GR has been started.



◆ Steps

1. Select "Online" → "Online Editing" from the menu bar.
2. Select "Tools" → "ROM↔RAM Transfer" from the menu bar.

The "ROM <=> RAM Transfer" dialog box displays.

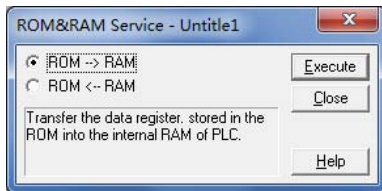

3. Select a transfer direction. Click the [Run] button.

For ROM-> RAM transfer, transfer from the F-ROM area to the data register area.

For RAM-> ROM transfer, transfer from the data register area to the F-ROM area.



◆ Emphasis

- Only PROG. mode can be performed.
- All area data in the data register set as hold type will be transferred.

6.3 Functions of the Main Memory Card

6.3.1 Function Outline

The main memory card includes functions such as storage backup, replication and real-time clock. Only one of the functions can be installed to the FP-XH control unit.

■ Main memory function

Item	Specification	
Calendar clock function (real-time clock)	Setting items	Year (last 2 numbers in the Gregorian calendar), month, day, hour (24-hour) minute, second, week
	Accuracy	0°C: Month error in 104 seconds or less, 25°C: Month error in 51 seconds or less, 55°C: Month error in 155 seconds or less
Main memory function	Memory capacity	Flash-ROM (512kB)
	Storable data	System register, ladder diagram program, comment data (328 kB) F-ROM data area, security function (password, upload prohibited)

6.3.2 Setting of the Main Memory Unit

■ Setting of the Function Toggle Switch

Confirm the switch position before installation.

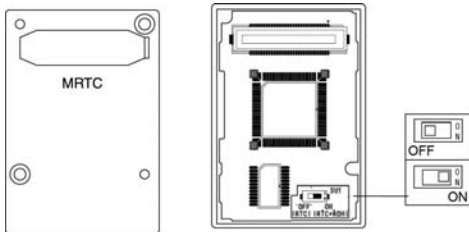

Switch position	Specification
OFF (RTC)	Position of factory setting. Only runs the real-time clock function.
ON (RTC + ROM)	The real-time clock function and main memory function are activated.

6.4 Main memory function

6.4.1 Function Outline

Use the main memory function when backuping and duplicating the program and data saved in the control unit controller.

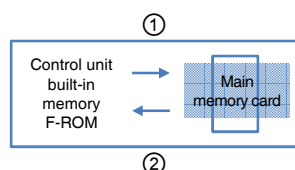

■ Control unit ← → main memory transfer

Transfer direction	Transfer method	Transfer content
①	Operations Using the Tool Software	(Data must be transmitted) Ladder diagram program, system register, position control data, safety information (password)
		(Data selected via dialog boxes) Safety information (upload prohibited), comment data, F-ROM data area (note 1) (note 2)
②	Operations Using the Tool Software	(Data must be transmitted) Ladder diagram program, system register, position control data, safety information
		(Data selected via dialog boxes) (note 3) comment data, F-ROM data area
	Switch to RUN mode Power ON in RUN mode	All contents written into the main memory unit are transferred to the internal memory of the control unit (F-ROM).

(Note 1): According to storage block No., specify the F-ROM data area in 2K character unit.

(Note 2): Delete the items unselected during built-in memory → main memory transferring from the main memory.

(Note 3): There is no comment data on the main memory. For the F-ROM data area, select via the menu is not available.

6.4.2 Before Turning on the Power

When the main memory card function toggle switch is ON (RTC + ROM) and the main memory function is active, depending on the different modes when the power is ON, the operation changes as follows.

- When the power is turned on in PROG. mode
 - When the power is turned on, change to the state indicating that data exists in all control units and main memory units (program, comments, system register data, data register).
 - Through the operation of the tool software, built-in memory → main memory transfer or main memory → built-in memory transfer can be performed.
 - When you copy the data saved in the control unit controller to the main memory card, turn on the power in PROG. mode. When you switch to RUN mode, transfer the contents of the main memory card to the built-in memory.
- When the power is turned on in RUN mode
 - When the power is turned on, transfer the data saved in the main memory unit (program, comments, system register data, data register) to the memory of the control unit controller.
 - Data saved in the control unit controller before powering on will be overwritten.
 - When the required data (program, comments, system register data, data register) has already saved to the main memory, turn on the power in RUN mode.



◆ Emphasis

- Perform the installation of the main memory card and the data transmission from the control unit controller to the main memory card after the setting and program editing are completed. Depending on the different operating conditions, the following errors will occur.

Error message	Operating conditions
42FromPLC: Basic step error NOT support error	When the program before conversion has been saved in the offline state
63FromPLC: Application error mode error	When you want to perform the transfer operation of the main memory card in RUN mode.
65FromPLC: Application error protection error	When you want to edit the program with the main memory card installed.
The main memory is not installed in the PLC connected.	The function toggle switch in the main memory card can not switch to ON (RTC + ROM side). Or the main memory card is not installed.

- When performing card assembly and disassembly with the power turned on, a I/O check exception error will occur.

6.4.3 Transferring Data to the Main Memory Card

Comments and data register set through the program, system register and options can be transferred to the main memory card.

■ Operating steps

When transferring data from the control unit to the main memory card, use the FPWIN GR to operate by following the steps below. Explain it as belows assuming that the FPWIN GR has been started.



◆ Steps

1. Select "Online" → "Online Editing" from the menu bar.
2. Select "Tools" → "Memory ↔ Main Storage" from the menu bar.

The "Memory <=> Main Memory Transmission" dialog box displays.

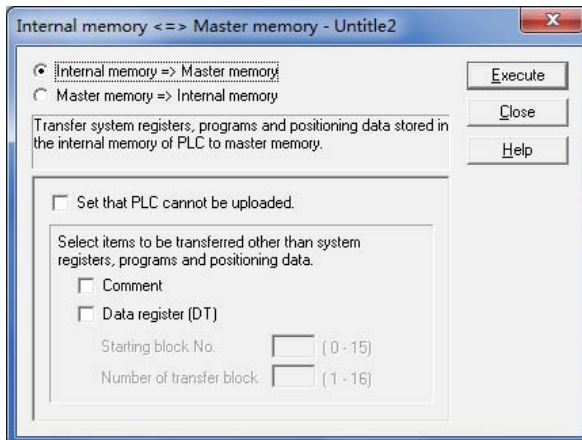

3. Select a transfer direction. Click the [Run] button.

The message is displayed at the end of the transmission.



■ Option setting

Type	Description
Upload prohibited	Create the main memory card set in the upload prohibited status when the check box is selected. The control unit in which installed the main memory card and perform transferring changes to upload prohibited status.
Comments	Transfer the comments saved in the control unit controller built-in memory (F-ROM) (I/O comments, descriptions, comments between the lines) when the check box is selected.
F-ROM data area (for data register transfer)	Transfer the data for data register saved in the F-ROM data area of the control unit controller to the main memory card when the check box is selected. Specify the starting block No. and the number of the transfer blocks. The unit of the storage block is 2 characters. The maximum number of the storage blocks can be transferred to the main memory is 20 (40,960 characters).

■ Assigning of the F-ROM data area

Storage block No.	DT number conversion range		Storage block No.	DT number conversion range	
0	DT0	DT2047	16	DT30768	DT32815
1	DT2048	DT4095	17	DT32816	DT34863
2	DT4096	DT6143	18	DT34864	DT36911
3	DT6144	DT8191	19	DT36912	DT38959
4	DT8192	DT10239	20	DT38960	DT41007
5	DT10240	DT12287	21	DT41008	DT43055
6	DT12288	DT14335	22	DT43056	DT45103
7	DT14336	DT16383	23	DT45104	DT47151
8	DT16384	DT18431	24	DT47152	DT49199
9	DT18432	DT20479	25	DT49200	DT51247
10	DT20480	DT22527	26	DT51248	DT53295
11	DT22528	DT24575	27	DT53296	DT55343
12	DT24576	DT26623	28	DT55344	DT57391
13	DT26624	DT28671	29	DT57392	DT59439
14	DT28672	DT30719	30	DT59440	DT61487
15	DT30720	DT30767	31	DT61488	DT65535



◆ Emphasis

- Temporarily delete all data in the main memory card when the transmission begins. Comments and F-ROM data values that are not selected as the transmission range will not be saved in the main memory card.
- Transfer data from the control unit built-in RAM to the F-ROM area through the "RAM → Transfer Function" of the tool software or P13 (ICWT) instruction.
- Writing by P13 (ICWT) instruction and reading by F12 (ICRD) instruction can perform up to 32 blocks (up to 65536 characters).

6.4.4 Transfer from the Main Memory Card to the Unit Controller

The data saved in the main memory card can be transferred to the control unit controller by the following methods.

■ Operating steps

Use FPWIN GR and follow these steps to transfer data to the main memory card from the control unit. Explain it as belows assuming that the FPWIN GR has been started.



◆ Steps

1. Select "Online" → "Online Editing" from the menu bar.
2. Select "Tools" → "Built-in Memory⇔Main Storage" from the menu bar.

The "Built-in Memory <=> Main Memory Transfer" dialog box displays.

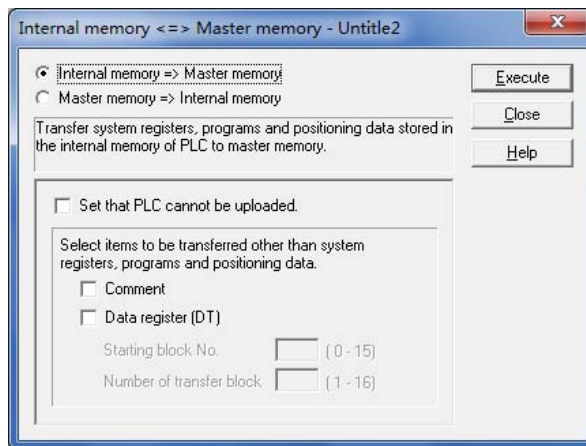

3. Change the transfer direction to "Main Memory => Built-in Memory", click the "Run" button.

The message displays after the transfer is completed.



◆ Emphasis

- After the temporary transfer, the contents in the main memory card and the built-in memory are checked. The transfer process is not performed if consistent.

■ Option setting

Type	Description
Comments	Comments saved in the main memory card (I/O comments, descriptions, comments between the lines) are transferred to the control unit controller built-in memory (F-ROM) when the check box is selected. The check box is not displayed when there is no comment data saved in the main memory unit.
F-ROM data area data register	The data saved in the main memory card is transferred to the F-ROM data area of the control unit controller when the check box is selected. The check box is not displayed when there is no data saved in the main memory unit.

6.4.5 Use between the Main Memory Card Models

The PLC creating a main memory card and the PLC to install have the following restrictions.

■ Use between FP-XH control unit models

- It can be used when the output type and I/O points are consistent. 30 points, 40 points and 60 points are operated as the same group.
- When the combination can not be used, a self-diagnostic error (E25) will occur.

		PLC creating a main memory									
		Relay Output Type				Transistor Output Type					
		C14	C30	C40	C60	C14	C30	C40	C60		
PLC to be installed	Relay Output Type	C14	●	E25	E25	E25	E25	E25	E25	E25	E25
		C30	E25	●	●	●	E25	E25	E25	E25	E25
		C40	E25	●	●	●	E25	E25	E25	E25	E25
		C60	E25	●	●	●	E25	E25	E25	E25	E25
	Transistor Output Type	C14	E25	E25	E25	E25	●	E25	E25	E25	E25
		C30	E25	E25	E25	E25	E25	●	●	●	●
		C40	E25	E25	E25	E25	E25	●	●	●	●
		C60	E25	E25	E25	E25	E25	●	●	●	●

(Note) ●: Operable, E25: A self-diagnostic error occurs

■ Actions when a self-diagnostic error (E25) occurs

- You can not switch to RUN mode. Unable to perform the transfer from the main memory to the built-in memory.
- Transferring from the built-in memory to the main memory can be performed.

■ Use between main memory units created by the old model FP-X control unit

- Under the same conditions on the above table, the main memory units created by the old model FP-X control unit can be installed to the FP-XH control unit for using.
- Main memories created by the FP-XH can not be used in the FP-X control unit.

6.5 Calendar clock

6.5.1 Function Outline

- The main memory card has calendar clock function.
- The time data is stored in the special data register for reading and using via the user program.

■ Functions of the main memory unit

Item	Specification	
Calendar clock function (real-time clock)	Function	Year (last 2 numbers in the Gregorian calendar), month, day, hour (24-hour) minute, second, week Applicable until 2099. Applicable during leap years.
	Accuracy	0°C: Month error in 104 seconds or less, 25°C: Month error in 51 seconds or less, 55°C: Month error in 155 seconds or less

■ Areas used via the calendar clock

Special DT number	Data content				Read	Write
	High byte		Low byte			
DT90053	Time data	H00 - H23	Minute data	H00 - H59	○	×
DT90054	Minute data	H00 - H59	Second data	H00 - H59	○	○
DT90055	Day data	H00 - H31	Time data	H00 - H23	○	○
DT90056	Year data	H00 - H99	Month data	H00 - H12	○	○
DT90057	-		Week data	H00 - H06	○	○

(Note 1): Specifies any week data within the range of H00 - H06.

6.5.2 Calendar Clock Setting

You can set the calendar clock through the tool software or the user program.

■ Tool software setting

Select the "PLC Date / Time Setting" menu. If the week data is required to set, please set through the user program.

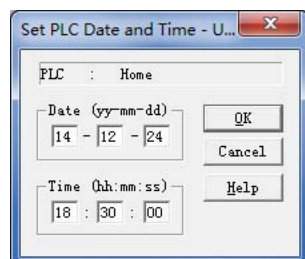

◆ Emphasis

- Backup the calendar clock data through a battery. Install the battery before setting.

■ Setting based on the user program

- After the time data is written in the special data register DT90057 - DT90054, write H8000 in DT90058. Perform the transmission by using differential instruction or following the order of H8000 -> H0000. Remember not to input H8000 continuously.

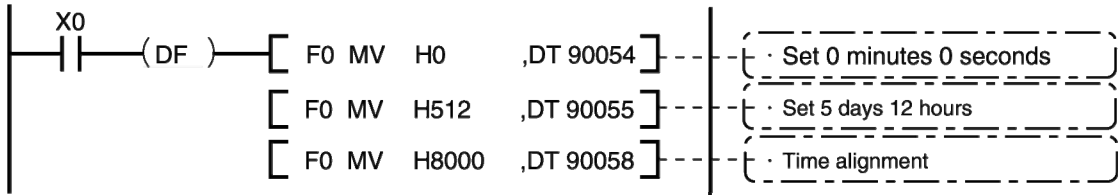

6.5.3 Calendar Clock Application Examples

■ Application example (regular automatic start)

Use the calendar clock (real-time clock) function to output 1 second (Y0) signal at 8:30 am every day. In this example, the "hour, minute data" stored in the special data register DT90053 are used to output signal regularly.

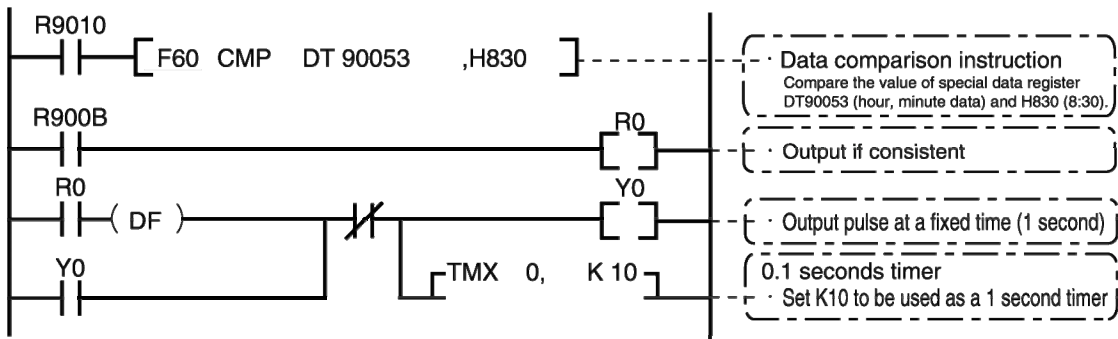

In DT90053, the "hour data" and "minute data" are respectively stored in the high 8 bytes and low 8 bytes in the form of BCD. When compare this "hour, minute data" and the value of any time (BCD), use the special internal relay R900B (= flag) to check if the time is consistent.

7

Security Functions

7.1 Password Protection Function

7.1.1 Function Outline

■ Password protection function outline

The function that forbid the reading out and writing in of the program and system register by setting a password. The password setting method has the following two types.

1. Set by using the programming tool
2. Set by instructions (SYS1 instructions)

■ Characters can be used by the password

Password digits	Characters can be used
4-digit password	4 characters of the "0" to "9" and "A" to "F" (16 characters) can be used.
8-digit password	You can use 8 or less half-width alphanumeric characters (case sensitive) and symbols.
32-digit password	You can use 32 or less half-width alphanumeric characters (case sensitive) and symbols.

(Note 1): When using the 32-digit password function, the version of the FP-XH control unit controller must reach Ver1.1 or later, and the FPWINGR must reach Ver.2.94 or later.



◆ CAUTION

- Never forget your password. You can not read the program if you forget your password. This is not possible even you ask for help from our company.

7.1.2 Tool software setting

■ Setting based on FPWIN GR

1. Select [Online (L)] → [Online Editing (N)] from the menu bar, or press <CTRL> + <F2> keys simultaneously.

The screen switches to [Online Monitoring].

2. Select [Tools (T)] → [PLC Password Setting (P)] from the menu bar.

The "PLC Password Setting" dialog box displays.

■ PLC password setting dialog box

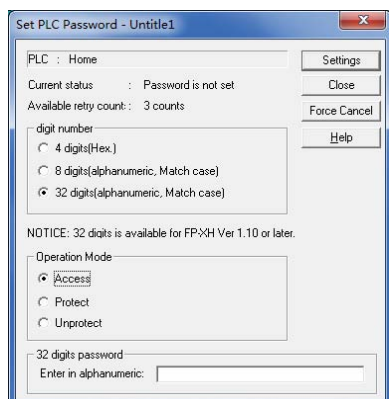

①	Display the current status of the password setting.
②	Specify the type of passwords used.
③	Specify password behavior. Allow Access: enter the password for program access operation. No Access: a password is set. Remove Password: remove the password setting.
④	Enter the password.

■ Confirmation of password setting contents

Item		Setting Contents
Current state	Password is not set	No password is set.
	xx bit no access (note)	A password is set, no access.
	xx bit allow access (note)	A password is set, allow access. (Password input is completed, the program can be accessed.)
Retry number		The maximum number for consecutive password input. Each time the password is entered incorrectly, the retry number decreased (up to 3 times). If there has been three consecutive failed password attempts, you can not access the program. To reenter the password, set the PLC's power to OFF / ON and reboot.

(Note): XX is one of 4, 8, 32 depending on the digits of the password set.



◆ CAUTION

- When the "Allow Access" status stays unchanged, if the PLC power supply is set to OFF / ON, it will become password protection status again.

■ Setting to prohibit access with a password

1. Select [Tools (T)] → [PLC Password Setting (P)] from the menu bar.
The "PLC Password Setting" dialog box displays.



2. Set the items in the table below, click [Set] key.

Item	Setting content
Digits	Select "4 digits" or "8 digits".
Operation mode	Select "No Access".
4, 8, 32-digit password	Enter any password to be set.

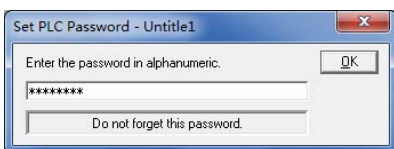

3. In order to confirm, enter the password again, click [OK] key.
The following information is displayed when entering a state (protected state) that is forbidden to write / read.

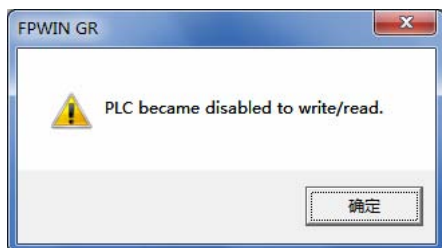

4. Click [OK] key.

■ Setting to allow access with a password

1. Select [Tools (T)] → [PLC Password Setting (P)] from the menu bar.
The "PLC Password Setting" dialog box displays.

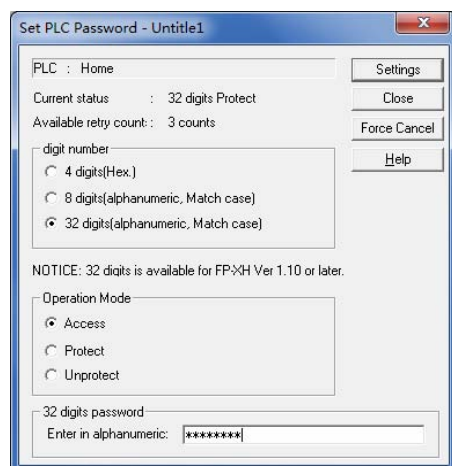

2. Set the items in the table below, click [Set] key.

Item	Setting content
Digits	Select "4 digits" or "8 digits".
Operation mode	Select "Allow Access".
4, 8, 32-digit password	Enter a set password.

When allowing access, the following information displays.

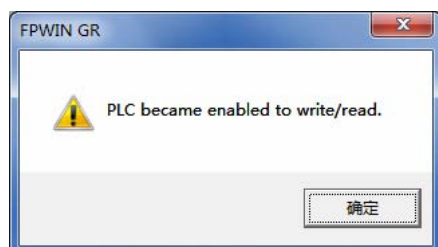

3. Click [OK] key.



◆ CAUTION

- When the "Allow Access" status stays unchanged, if the PLC power supply is set to OFF / ON, it will become password protection status again.

■ Password protection removal

The following 2 methods can be used to remove password setting.

	Contents	Program
Password removal	Specify and remove the logged password.	Hold all
Compulsory removal	Remove the password by deleting all programs and security information.	Delete all (also delete upload prohibited setting)

■ Password protection removal

1. Select [Tools (T)] → [PLC Password Setting (P)] from the menu bar.

The "PLC Password Setting" dialog box displays.



2. Set the items in the table below, click [Set] key.

Item	Setting content
Digits	Select "4 digits" or "8 digits".
Operation mode	Select "Remove Password".
4, 8, 32-digit password	Enter a set password.

After the password removal is completed, the following message displays.

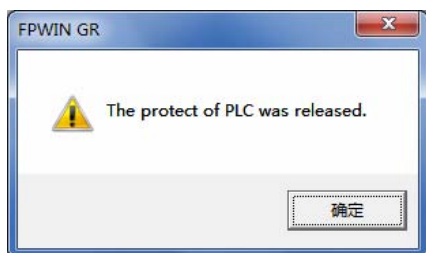

3. Click [OK] key.



◆ CAUTION

- The password removal operation can only be performed in the "Allow Access" status.

■ Compulsory removal method (programs and security information all deleted)

1. Select [Tools (T)] → [PLC Password Setting (P)] from the menu bar.
The "PLC Password Setting" dialog box displays.

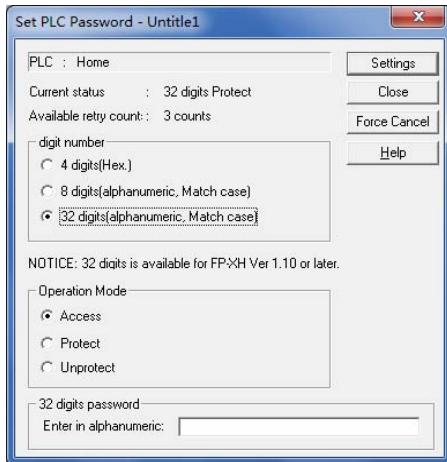

2. Click [Compulsory Removal] key.
The confirmation message displays.

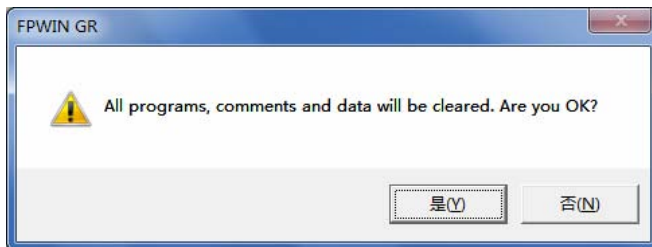

3. Confirm the message and click [Yes] key.
The current status is displayed as "No Password Set". All programs and security information have been deleted.

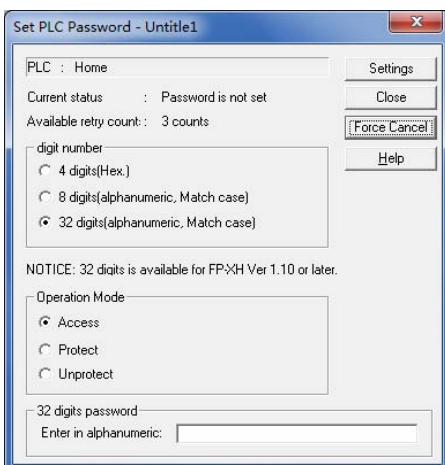

7.2 Program Upload Prohibited Function

7.2.1 Function Outline

- Overview of the program upload prohibited function
- The function that prohibit access to program and system register through the setting of program upload prohibited.
- Please note that uploading the ladder diagram program and system register is not possible after setting as upload prohibited.
- Use the programming tool to remove the setting. However, all ladder diagram programs or system registers, password information, etc. will be deleted when removing.
- On the computer, you can use the programming tool to read out the management file for online editing. However, when the program is not consistent, it indicates that the program is damaged. In the case of using this function, please save the ladder diagram program in the form of file and conduct management.
- Setting relation with the password protection function
- For PLC that has been set this function, the password setting is also available.
- For PLC that has been set a password, this function is also available.



◆ CAUTION

- If compulsorily remove the upload prohibited setting, all programs and security information will be deleted. It is impossible to recover the deleted programs even you ask for help from our company.

7.2.2 Tool software setting

■ Setting based on FPWIN GR

1. Select [Online (L)] → [Online Editing (N)] from the menu bar, or press <CTRL> + <F2> keys simultaneously.

The screen switches to [Online Monitoring].

2. Select [Tools (T)] → [Upload Setting (U)] from the menu bar.

The "Upload Setting" dialog box displays.



3. Select "Set as can not upload the program from the PLC" and press the "Execute (E)" button.

■ Compulsory removal based on FPWIN GR

In the "Upload Setting" dialog box, select "Remove upload protection compulsorily", and then press the [Execute (E)] key.

7.3 Security Function Applicability List

7.3.1 Control Unit Controller

The safe operating conditions of the control unit controller vary according to the presence or absence of the main memory card.

■ No main memory card

		Security status				
		Security function is not set	Upload prohibited	4-digit password	8-digit password	32-digit password
Setting / removing operation	Upload prohibited	○		○	○	○
	4-digit password	○	○		×	×
	8-digit password	○	○	×		×
	32-digit password	○	○	×	×	

○: Available ×: Not available

■ When a main memory card is installed

		Security status				
		Security function is not set	Upload prohibited	4-digit password	8-digit password	32-digit password
Setting / removing operation	Upload prohibited	×		×	×	×
	4-digit password	×	×		×	×
	8-digit password	×	×	×		×
	32-digit password	×	×	×	×	

○: Available ×: Not available

8

Other Functions

8.1 Analog potentiometer

8.1.1 Function Outline

■ Function Outline

- The FP-XH control unit equipped with an analog potentiometer.
- When rotating the potentiometer, the value of the special data register DT90040 changes between K0 - K4000. The set values inside the PLC can be changed without using a programming tool, therefore, it can be used to analog timers that change the set values by external rotary potentiometer.

8.1.2 Analog Potentiometer Application Examples

■ Timer application examples

The value of the special data register (DT90040) corresponding to the analog potentiometer V0 is transmitted to the set value area (SV0) of TMX0, and the timer time is set.

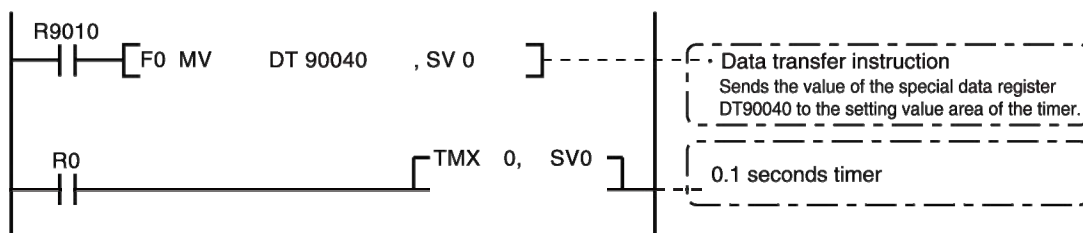

8.2 Input Time Constant Setting Function

8.2.1 Function Outline

- Actions when setting the input time constant processing
- It is easy to set the time constant of the control unit controller input after changing the value of the system register 430 - 437 with the programming tool.
- If this setting is carried out, it will run in accordance with the following equivalent circuit. Once set, you can remove the input interference and vibration.

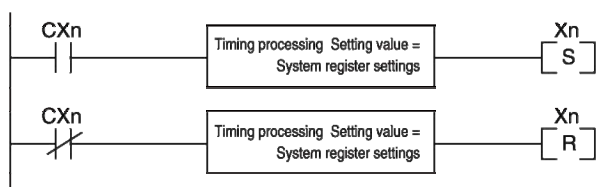

CXn=Xn node input signal
Xn=input Xn image storage



◆ CAUTION

- Receiving an input signal of the X contact can be performed by the common I/O refresh time.
- For the input in the time constant processing, such as executing part of the refresh instructions, the time constant processing is invalid, and the input status at this time is read out for setting.
- If use the F182 (FILTR) instruction, the time constant processing can be set even for the input outside the control unit controller (expansion unit).
- Using the time processing in the equivalent circuit requires no time instruction.
- For the setting to interrupt the high-speed counter or pulse catch, the time constant processing is ineffective.

■ Input time constant setting function and applicable models

System register number	Control unit controller I/O number	Applicable models	
		C14	C30 / C40 / C60
430	X0 - X3	○	○
431	X4 - X7	○	○
432	X8 - XB	○	○
433	XC - XF	○	○
434	X10 - X13	○	○
435	X14 - X17	○	○
436	X18 - X1B	○	○
437	X1C - X1F	○	○

9

Troubleshooting

9.1 Self-diagnosis function

9.1.1 Status display LED of the control unit

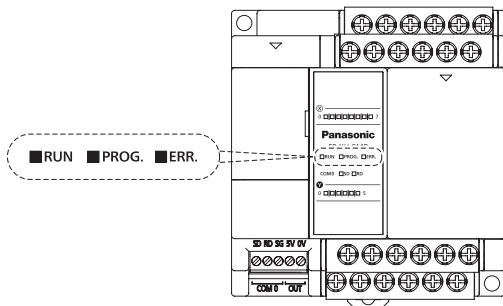

- When an error occurs in the embedded control unit, judge the current situation and stop the running self-diagnosis function as needed.
- When an error occurs, the status display LED of the control unit controller is as shown in below table.

■ Self-diagnosis related LED display

	LED display			Contents	Run
	RUN	PROG.	ERR.		
Normal	○	×	×	In normal operation	Run
	×	○	×	Prog mode In prog mode, even if forcible output is performed, LED does not blink.	Stop
	△	△	×	In RUN mode, during forcible input/output, RUN and PROG. LEDs will blink one by one.	Run
Exception	○	×	△	Self-diagnosis error (in operation)	Run
	×	○	△	Self-diagnosis error (being stopped)	Stop
	—	○	○	System monitoring timer stops working	Stop

○: ON, △: Blink, ×: off, —: on or off

9.1.2 Status Display LED of the FP-X Expansion FP0 Adapter

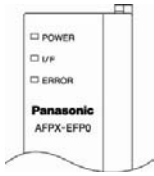

- When an error occurs in the FP-X expansion FP0 adapter, judge the current situation and stop the running self-diagnosis function as needed.
- When an error occurs, the status display LED of the control unit controller is as shown in below table.

■ Self-diagnosis related LED display

	LED display			Contents
	POWER	I / F	ERROR	
Normal	○	○	×	In normal operation
Abnormal	○	△	×	FP0 / FP0R expansion unit is not connected.
	○	○	△	When the power of the control unit is turned on, the connected FP0 expansion unit detached. The data access between the expansion FP0 adapter and the FP0 / FP0R expansion unit failed due to interference.
	○	×	×	The expansion FP0 adapter power is turned on after the control unit.

○: ON, △: Blink, ×: off, —: on or off

9.1.3 Operation mode in case of exception

- When an error occurs, the system usually stops running. Depending on various type of exception, you can set the system register to choose between keep running or stop.

■ FPWIN GR system register setting dialog box

If an error occurs when FPWIN GR is used to set PLC, select "Option (O)"→"PLC System Registrar Setting" in the menu bar, and click "Action on Error" tab. The following screen shows.

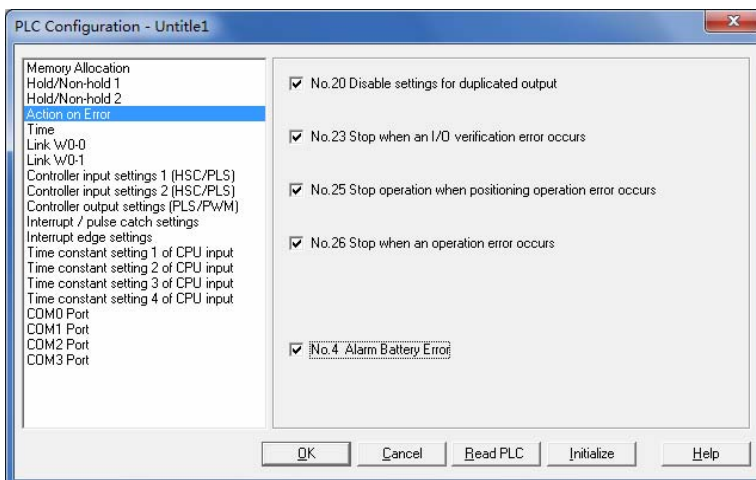

9.2 Troubleshooting Exceptions

9.2.1 ERROR LED blinking

■ Situation

A syntax error or self-diagnosis error occurs.

■ Handling method



◆ Steps

- 1 Use the programming tool to confirm the error code.

When a PLC error occurs during programming and commissioning, the Show Status dialog box will be displayed automatically. Please confirm the contents of self-diagnosis errors.

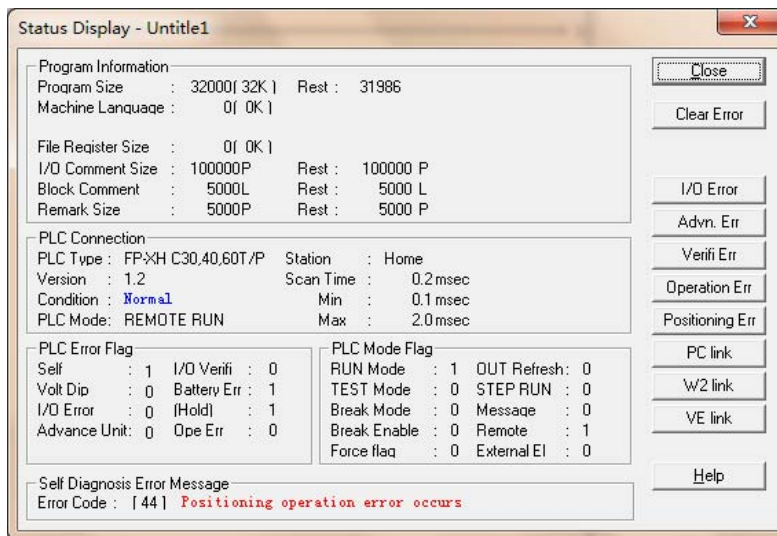

2. Confirm the error code and modify the error reason.

■ Error code and handling method

Error code	Situation	Handling method
1 - 9	A syntax error occurs.	<ul style="list-style-type: none"> ● Switch PLC to PROG mode and clear error status. ● Use FPWIN GR for overall check and identify the address of syntax error and modify the program.
above 20	A self-diagnosis error occurs.	<ul style="list-style-type: none"> ● Adjust settings and programs according to the error code list. ● Use the programming tool in PROG mode and resolve the error status.



◆ Emphasis

- When an error with a code above 43 occurs, press the Clear Error button in the status display dialog box to clear the error status. In PROG mode, connecting to power supply again also can clear an error. However, contents of the computation storage except data for keeping will be cleared.
- When a position control error (an error with a code of 44) occurs, you can confirm the details of the error. Click the Position Control Error button to confirm the error code.
- When a computation error (code 45) occurs, the address in which an error occurred is saved to special data register DT90017 and DT90018. Before resolving the error status, click the Computation Error button in the dialog box and view the address in which an error occurs.



◆ Reference

For how to handle the position control error (error code 44), see the next page.

9.2.2 When Not Switched to RUN Mode

■ Situation

When a syntax error occurs or running stops, a self-diagnostic error occurs.

■ Handling method

Confirm the situation according to the following steps.



◆ Steps

1. Confirm whether the ERR. is lit or not.
2. Use the tool software to perform "Overall Check" to confirm the syntax error.

9.2.3 When ERR.LED Lights Up

■ Situation

The system monitoring timer is in operation, the controller stops running.

■ Handling method



◆ Steps

1. Switch to PROG. mode and turn on the power supply again.
If the ERR. LED lights again, it may be due to abnormal unit. If off, it may be caused by interference and other temporary reasons.
2. Switch to RUN mode.
If the ERR. LED lights up after switching to RUN mode, it means that the program has timed out. Rerun the program.
3. Check the surrounding environment to confirm if there is interference.
If the program itself is OK, it may be due to the surrounding environment. Check wirings (includes grounding wire).



◆ Emphasis

- When rechecking the program, confirm the following items.
Example 1) Confirm whether the program is an infinite loop according to the instructions controlling JP instruction, LOOP instruction and other program processes.
Example 2) The interrupt instruction is continuously executed?

9.2.4 If all LEDs are not lit

■ Situation

It may be due to insufficient power supply.

■ Handling method

Confirm the situation according to the following steps.



◆ Steps

1. Recheck the terminal and wiring for looseness after turning off the power.
2. Check that the voltage is applied within the allowable range.
3. Check whether the voltage fluctuation is too large.
4. When sharing power with other devices, disconnect the power from the other devices.

If the unit LED lights up during this operation, it may be due to insufficient power supply capacity. Redesign the power supply.

9.2.5 When Protection Error Message Shows

■ Situation

It may be due to the main memory card is used or a password is set.

■ Handling method (when using the main memory card)

In the case of using the main memory card, the program can not be edited. Turn the power off and remove the main memory card.

■ Handling method (when using the password function)



◆ Steps

1. Select "Tools" → "PLC Password Setting" in FPWIN GR.
The "PLC Password Setting" dialog box displays.
2. Select "Allow Access" and click [Set] button.
Remove the protection status.



◆ Emphasis

- Pressing [Compulsory Removal] button will delete all programs saved to the PLC.

9.2.6 When the Output is Not Normal

■ Situation

It may be due to the program, I/O assignment and other software problems combined with the wiring, power supply and other hardware problems.

■ Handling method (check of the output side)

Follow the check order of the output and input side to confirm the situation.



◆ Steps

1. Verify if the output display LEDs of the input and output units are lit.
If lit, perform the next step; if not lit, perform step 4.
2. Recheck the terminal for loose and the wiring status of the load.
If the unit LED lights up during this operation, it may be due to insufficient power supply capacity. Redesign the power supply.
3. Verify if the voltage across the load is normal.
If the voltage is normal, it may be due to an abnormal load. If the voltage is not applied, it may be due to an abnormality in the unit's output.
4. Use the tool software to monitor the output status.
If the monitor state is ON, it may be due to a dual output is used.
5. Use the forcible input / output function of the tool software to force the corresponding outputs turn to ON / OFF.
When the unit output LED is lit, make further checks on the input side. If not lit, it may be due to abnormal unit output part.

■ Handling method (check of the input side)

Confirm the situation according to the following steps.



◆ Steps

1. Verify if the input display LED of the unit is lit.
If not lit, perform the next step; if lit, perform step 3.
2. Recheck the terminal for loose and the wiring status of the input device.
If the unit LED lights up during this operation, it may be due to insufficient power supply capacity. Redesign the power supply.
3. Verify if the voltage across the input terminal is normal.
If the voltage is normal, it may be due to an abnormal unit input. If the voltage is not applied, it may be due to an abnormal power or input device.

4. Use the tool software to monitor the input status.

If the monitor state is OFF, it may be due to an abnormal unit input. If the monitor state is ON, recheck the program. When the input device is two-wire sensor, it may be caused by a leakage current.



◆ Emphasis

- When rechecking the program, note the following items.
 1. Check if the output has been rewrote, for example, a dual output is used.
 2. Check if the program process has changed via control instructions such as MCR and JMP instruction.
 3. Check if the allocation of the I/O mapping is consistent with the installation state.

9.2.7 If Expansion Units Not Operated

■ Situation

The setting of the expansion unit may be incorrect.



◆ Steps

1. Verify if the expansion unit terminal is set correctly.

Verify if the terminal setting of several units is made.
2. Verify if the expansion FP0 adapter is attached to the end.

When the FP-X expansion FP0 adapter is attached to the end, the other expansion unit does not need to be set in the terminal.
3. Verify if a momentary outage or other short time power on/off are occurred.

Sometimes, it is unable to identify the expansion unit due to momentary outage and other short time power on/off. Reconnect the power.

9.2.8 If a Communication Error Occurs (RS-232C)

■ Object

Order Number	Communication Interface	Communication Port No. Assigned				
		Master computer	Card installation part 1		Card installation part 2	
		COM0	COM1	COM2	COM3	COM4
Control unit standard configuration	RS-232C (3-wire) × 1 channel	●				
AFPX-COM1	RS-232C (5-wire) × 1 channel		●		●	
AFPX-COM2	RS-232C (3-wire) × 2 channel		●	●	●	●
AFPX-COM4	RS-232C (3-wire) × 1 channel			●		●
AFPX-COM5	RS-232C (3-wire) × 1 channel			●		●

■ Situation

Connections and settings may be incorrect.



◆ Steps

1. Confirm the setting of the system register.
Verify if the setting corresponding to the communication port number assigned is correct. When selecting the inter-PLC link, verify if the connection area is repeated.
2. Verify if the CS signal is ON.
When using 3-wire type, set the connection RS signal and CS signal to ON. When using 5-wire type, verify the RS signals of the communication card LED and the matched devices.
3. Verify the connection with the matched devices.
Confirm that the SD terminal of the matched device is connected to the RD terminal at the PLC side, and the RD terminal of the matched device is connected to the SD terminal at the PLC side. Also, make sure the SG terminals from both devices are connected.

9.2.9 If a Communication Error Occurs (RS-422)

■ Object

Order Number	Communication Interface	Communication Port No. Assigned				
		Master computer	Card installation part 1		Card installation part 2	
		COM0	COM1	COM2	COM3	COM4
AFPX-COM3	RS-485 / RS-422 × 1 channel		●		●	

■ Situation

Connections and settings may be incorrect.



◆ Steps

1. Confirm the setting of the system register.
Verify if the setting corresponding to the communication port number assigned is correct. When selecting the inter-PLC link, verify if the connection area is repeated.
2. Verify if the terminal station is connected properly.
3. Verify if the transmission cable is securely connected to the data send terminal and data receive terminal.
4. Verify if the transmission cable is within the specifications.

9.2.10 If a Communication Error Occurs (RS-485)

■ Object

Order Number	Communication Interface	Communication Port No. Assigned				
		Master computer	Card installation part 1		Card installation part 2	
		COM0	COM1	COM2	COM3	COM4
AFPX-COM3	RS-485 / RS-422 × 1 channel		●		●	
AFPX-COM4	RS-485 × 1 channel		●		●	
AFPX-COM6	RS-485 × 2 channel		●	●	●	●

■ Situation

Connections and settings may be incorrect.



◆ Steps

1. Confirm the setting of the system register.
Verify if the setting corresponding to the communication port number assigned is correct. When selecting the inter-PLC link, verify if the connection area is repeated.
2. Verify if the terminal station is connected properly.
Do not set the unit outside both sides of the network as the terminal station.
3. Verify if the transmission cable is securely connected to the transmission terminals of the devices by (+) and (+), (-) and (-).
4. Verify if the transmission cable is within the specifications.
Do not use more than one type of cable.

9.2.11 If a Communication Error Occurs (Ethernet)

■ Object

Order Number	Communication Interface	Communication Port No. Assigned				
		Master computer	Card installation part 1		Card installation part 2	
		COM0	COM1	COM2	COM3	COM4
AFPX-COM5	Ethernet x 1 channel		●		●	

■ Situation

Connections and settings may be incorrect.

■ Verification steps (when the ERR.LED is not lit)

Connections and settings may be incorrect.



◆ Steps

1. Confirm the setting of the system register.
Verify if the setting corresponding to the communication port number assigned is correct.
2. Verify if the LAN cable is securely connected to the card or computer.
3. When using the HUB during connection, verify if the power of the HUB has been connected.
4. Verify if the LINK / ACT LED is lit.
If not lit, it indicates that the LAN cable is not connected properly.
5. Verify the IP address and the IP address of the other end of the connection.
6. Verify if the transmission mode and speed of the COM1 port of the control unit controller are consistent with the communication environment setting of the FP-X communication card (AFPX-COM5).

■ Verification steps (when the ERR.LED is lit)

Connections and settings may be incorrect.



◆ Steps

1. Verify the status via the Configurator WD.
There is an IP address conflict on the network if the status displays "IP Conflict Error". Do not set conflicted IP address.
It is unable to get IP from the DHCP server if the status displays "DHCP Error". Verify if there is an exception in the network system.

10

Maintenance and Inspection

10.1 Precautions for Using Backup Battery

10.1.1 Backup Battery Replacement

You can replace the backup battery of the FP-XH control unit when the power is on. Please replace the backup battery according to the following steps.

■ Backup battery type (sold separately)

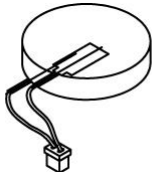
Appearance	Product Name	Specification	Order Number
	Backup battery for FP-XH	With connector	AFPXHBATT

■ Number of installed batteries

For FP-XH, only one battery can be installed.

■ Steps



◆ Steps

1. Power up the controller unit for more than five minutes.
When replacing the battery, charge up the built-in capacitor to maintain the memory contents.
2. Turn the power off.
3. Open the cover.
4. Remove the used batteries.
5. Install the new battery within 2 minutes after cutting off the power supply.
6. Close the card cover.



◆ Emphasis

- You can replace the battery of the FP-XH control unit when the power is on. If perform the replacement after cutting off the power, in order to charge up the built-in capacitor, power up for more than 5 minutes, and complete the replacement in less than 2 minutes. If the charging is not sufficient, it may lead to unstable calendar clock data. When closing the card cover, do not let the battery connector cable clap into the card cover.

10.1.2 Backup Battery Lifetime and Replacement Time

■ Backup Battery Lifetime

Main memory card	Type of Control Unit	Backup Battery Lifetime	Description
If installed	C14 / C30 / C40 / C60	More than 5 years	Run 8 hours per day
If not installed	C14 / C30 / C40 / C60		

(Note) Please note that the lifetime may be shortened due to different use conditions.

■ Backup battery abnormality detection and battery replacement time

- If the battery voltage drops, special internal relays (R9005, R9006) will turn to ON. Develop an program to send an outside abnormal warning as needed.
- If the system register No. 4 "Alarm Battery Error" setting is effective, the ERR.LED of the controller unit controller will flash.
- After the backup battery error is detected, the data can be maintained for about one week without power. However, please replace the battery immediately.



◆ CAUTION

- When special internal relays (R9005, R9006) are ON or the ERR.LED of the control unit is flashed, if the power outage lasts a week, the data saved in the memory may be unstable.
- Special internal relays (R9006, R9005) are independent of the system register setting, if a backup battery error has been detected, it will turn to ON.
- Regardless of when the backup battery error was detected, power up the control unit for more than 2 minutes when replacing the backup battery.

10.2 Inspection

Perform routine or periodic inspection to ensure the best use conditions.

■ Check Items

Check Items	Check Contents	Determination Criteria	Related Page
Power supply	Verify the control unit RUN / PROG.LED's lighting state	Normal if "Lit"	P.2-2 - P.2-4
Status display LED display	Verify RUN mode LED display Verify the ERR.LED	Lit when in RUN status Normal if "Unlit"	P.2-2 - P.2-4
Installation status	DIN rail installation, looseness Unit looseness and shaking	Required to be installed securely.	P.4-3, P.4-11 - P.4-12
Connection status	Terminal screw looseness near to crimp terminals connector looseness	No looseness Fastened in parallel Locked. The connector shall be tight.	P.4-5 - P.4-23
Unit supply voltage	Voltage between terminals	100-240 VAC or 24 VDC (all types)	P.2-6 - P.2-7
Input and output circuit supply voltage	Power supply voltage	100-240 VAC or 24 VDC (all types)	P.2-8 - P.2-11
Ambient environment	Ambient temperature, internal temperature ambient humidity, internal humidity environment	0 - +55°C 10-95%RH There should be no dust and corrosive gas	P.4-2
Backup battery	Control unit backup battery	Periodic replacement	P.4-4, P.10-2 - P.10-3

11

Specification

11.1 Control Unit Specifications

11.1.1 General Specification

■ General Specification

Item	Specification			
Ambient temperature	0 - + 55°C			
Storage temperature	-40 - + 70°C			
Ambient humidity	10 - 95% RH (non-condensing at 25°C)			
Storage humidity	10 - 95% RH (non-condensing at 25°C)			
Voltage resistance (detection current 5 mA)	Relay Output Type	Power terminals - grounding terminals	AC Power Supply Type 1500 VAC 1 minute	DC Power Supply Type 500 VAC 1 minute
		Power terminals - universal power supply terminals	1500 VAC 1 minute	-
		Input terminals - grounding terminals	1500 VAC 1 minute	500 VAC 1 minute
		Output terminals - grounding terminals	1500 VAC 1 minute	1500 VAC 1 minute
	Transistor Output Type	Power terminals - grounding terminals	1500 VAC 1 minute	500 VAC 1 minute
		Power terminals - internal circuit	1500 VAC 1 minute	
		Input terminals - grounding terminals	1500 VAC 1 minute	500 VAC 1 minute
		Output terminals - grounding terminals	500 VAC 1 minute	500 VAC 1 minute
	Insulation resistance (Test voltage 500 VDC)	Power terminals - grounding terminals	100 MΩ or more	100 MΩ or more
		Power terminals - universal power supply terminals		
Input terminals - grounding terminals				
Output terminals - grounding terminals				
Vibration resistance	5 - 8.4 Hz, single amplitude 3.5 mm 8.4 - 150 Hz, acceleration speed 9.8 m / s ² 10 minutes for X, Y, Z directions (1 octave/min)			
Shock resistance	147 m/s ² , 4 times for X, Y, Z directions			
Anti-interference performance	1000 V [P-P] pulse width 50 ns, 1 μ s (based on noise simulation method) (power terminal)			

■ Current consumption list (AC power supply type)

Model	For 100 VAC	For 200 VAC
C14R	185 mA or less	115 mA or less
C14T	175 mA or less	110 mA or less
C30R	330 mA or less	200 mA or less
C30T	310 mA or less	190 mA or less
C40R	345 mA or less	215 mA or less
C40T	320 mA or less	195 mA or less
C60R	380 mA or less	235 mA or less
C60T	335 mA or less	205 mA or less

■ Current consumption list (DC power supply type)

Model	For 24 VDC
C14RD	95 mA or less
C14TD	90 mA or less
C30RD	160 mA or less
C30TD	115 mA or less
C40RD	185 mA or less
C40TD	130 mA or less
C60RD	275 mA or less
C60TD	170 mA or less

■ Quality list

Model	Quality	Model	Quality
C14R	320 g	C40R	590 g
C14RD	280 g	C40RD	515 g
C14T	300 g	C40T	545 g
C14TD	265 g	C40TD	470 g
C30R	510 g	C60R	785 g
C30RD	440 g	C60RD	715 g
C30T	475 g	C60T	710 g
C30TD	405 g	C60TD	635 g

11.1.2 Performance specification

Item		Specification			
		C14	C30	C40	C60
Control IO points		14 points Input: 8 points Output: 6 points	30 points Input: 16 points Output: 14 points	40 points Input: 24 points Output: 16 points	60 points Input: 32 points Output: 28 points
Program mode / control mode		Relay symbol / cyclic operation mode			
Program memory		Built-in Flash-ROM (requires no backup battery)			
Comments storage		For I/O comments, descriptions, comments between the lines (requires no backup battery 1M byte)			
Instructions number	Basic instructions	About 110 kinds			
	Application instructions	About 220 kinds			
Program capacity		16k step:	24k / 32k / 40k step (switching) (note 1)		
Operation processing speed		Before 5k step : basic instruction 0.04 μ s / step, application instruction 0.22 μ s / step After 5k step : basic instruction 0.7 μ s / step, application instruction 1.73 μ s / step			
Basic scanning time IO refresh + basic time		CPU only: 0.12 ms or less Increases the time when using E16: 0.34 ms \times expansion unit number Increases the time when using E30: 0.47 ms \times expansion unit number Increases the time when using expansion FP0 adapter: 1.4 ms + FP0 expansion unit refresh time			
Operational memory	Link relay	External input (X)	1760 points (X0 - X109F) (note 2)		
		External output (Y)	1760 points (Y0 - Y109F) (note 2)		
		Internal relay (R)	8192 points (R0 - R511F) / 4096 points (R0 - R255F) (note 3)		
		Timer, counter (T / C)	Measures 1024 points (1008 points for the initial setting timer, 16 points for the counter) (note 4) timer (1msec / 10msec / 100msec / 1sec unit) \times 32767 measures counter 1-32767		
		Link relay (L)	2048 points (L0 - L127F)		
	Storage region	Data register (DT)	12k characters	64k, 32k, 12k characters (DT0 - 32764) (note 1)	
		Link data register (LD)	256 characters (LD0 - LD255)		
		Index register (I)	14 words (I0 - ID)		
Differential points (DF, DF /, DFI)		Program capacity			
Master control relay points (MCR)		256 points			
Label number (JMP + LOOP)		256 points			
Step ladder diagram number		1000 stroke			
Subprogram number		500 subprograms			
Interrupt program		Interruption via external input or interruption when the target value of the high-speed counter is consistent \times 8 programs Timer interrupt (0.5 ms unit or 10 ms unit) \times 1 program			
Sampling and tracking		Instruction or regular sampling, +3 words per 16 bits / sampling \times 1000 sampling			

(Note 1): When changing the system register No.0 (sequence program capacity), the data register (DT) capacity will also change.

(Note 2): The number of points in the above table is the point number of the operational storage. The actual number of points is determined by the combination of hardware.

(Note 3): It can be selected by the capacity of the system register No. 1 internal relay. When it is required to be compatible with the old model FP-X series control unit, choose 4096 points.

(Note 4): The number of timer points can be changed by the setting of the system register No. 5.

Item		Specification	
		Relay Output Type	Transistor Output Type
Inter-PLC link function		Up to 16 units, link relay 1024 points, link register 128 words	
Fixed scanning		Available	
Security Functions		Password (4-digit and 8-digit), program upload prohibited	
Self-diagnosis function		Watchdog timer, program syntax checking	
Program editing in RUN		Available (download in RUN, program rewrite in RUN, up to 512 steps)	
High speed counter (Note 5) (Note 6)	Controller input	Single phase 8ch or 2-phase 4ch single phase 8ch: each 10 kHz 2-phase 4ch: each 5 kHz	Single phase 8ch or 2 phase 4ch high speed single phase (4ch): 100 kHz medium speed single phase (4ch): 10 kHz high speed 2-phase (2ch): each 50 kHz medium speed 2-phase (2ch): 10 kHz
	Pulse input and output When the card installed	C14: single-phase 2ch or 2-phase 1ch C30 / 60 / 40: single phase 4ch or 2-phase 2ch (when the card installed) Single phase: 100 kHz, 2-phase: 50 kHz	Can not be installed
Pulse output / PWM output (Note 5) (Note 6)	Controller output	No	Pulse output: C14: 3ch, C30 / 40: 4ch, C60: 6ch Maximum output frequency: 100 kHz PWM output: 3ch (C14), 4ch (C14) 1 - 70 kHz (1000 resolution) 70.001 k - 100 kHz (100 resolution)
	Pulse input and output When the card installed	Pulse output: C14: 1ch, C30 / 40/60: 2ch 2 installed Maximum output frequency: each 100 kHz PWM output: 2ch 2 installed 1 - 70 kHz (1000 resolution) 70.001 - 100 kHz (100 resolution)	Can not be installed
Pulse catch input, interrupt input (note 6)		14 points (master input 8 points, pulse input and output card 3 points × 2)	8 points (master input 8 points)
Timer interrupt (note 6)		0.5 ms - 1.5 s (0.5 ms unit), 10 ms - 30 s (10 ms unit)	
Potentiometer input		1ch (K0 - K4000)	
Calendar clock		Year (last 2 numbers in the Gregorian calendar), month, day, hour (24h), minute, second, week. As of 2099. Applicable during leap years. Available only when the main memory card AFPX-MRTC and battery are installed	
Flash-ROM backup		Write guarantee times: less than 10000 times Automatic backup in case of power outage Counter 16 points, internal relay 128 points, data register 315 characters Can be operated through the tool software or F-ROM read and write instruction (F12 / P13) Backup in data register 2K characters	
Backup battery		The hold / non-hold area can be set with the system register.	
Battery lifetime		More than 5 years depending on the actual use condition (run 8 hours per day)	

(Note 5): The maximum counting speed of high-speed counter, pulse output, PWM output and the maximum output frequency indicate the specifications at 24 VDC and ambient temperature 25°C. Depending on the different voltage, temperature and function combination to be used, the frequency may be reduced.

(Note 6): The input and output used in the high-speed counter, pulse output, PWM output, pulse catch input and interrupt input functions can not be repeatedly allocated.

11.1.3 Communication Specifications

■ USB port (for tool software)

Item	Specification
Specification	USB2.0 Fullspeed
Communication Function	MEWTOCOL (slave)
Connector shape	USB miniB type

■ Communication port interface

Item		Specification		
Interface		RS-232C (non-insulated)	RS-422 (insulated)	RS-485 (insulated)
Communication type		1: 1 communication	1: 1 communication	1: N communication
Communication pattern		Half duplex	Half duplex	Two-wire half-duplex mode
Synchronous mode		Start-stop synchronous mode		
Transmission line		Multi-core shielded wire	Multi-core shielded wire	Shielded twisted pair wire or VCTF
Transmission distance (m)		15 m	Up to 1200m	Up to 1200m
Rate		2400, 4800, 9600, 19200, 38400, 57600, 115200, 230400/s		
Transmission code	Computer link	ASCII		
	Universal serial communication	ASCII, binary		
	MODBUS-RTU	Binary		
Transmission format	Data length	7 bit / 8 bit		
	Parity check	No / Yes (odd / even)		
	Stop bit	1 bit / 2 bit		
	Start character	STX Yes / STX No		
	End character	CR / CR + LF / No / ETX / Time (0 - 100ms)		
Connected stations		2 stations	2 stations	Up to 99 stations (up to 32 stations when C-NET adapter connected)

(Note 1): When connecting a commercially available device, please confirm it according to the device actually used. The number of stations, transmission distance and speed can be changed with the connected device.

(Note 2): The transmission distance, speed and the number of stations are within the range given in the following table.

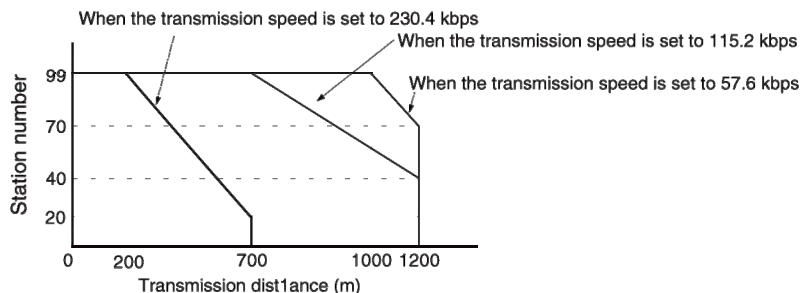

(Note 3): For functions used and combination limitations, refer to 1.3.4 Use limitations on Communication Function, 1.3.5 Limitations on Function Combination.

11.2 Operational Storage Area

■ List of operational memory area

Item		Specification	
Relays	External input (X) (note 1)	1760 points (X0 - X109F)	
	External output (Y) (note 1)	1760 points (Y0 - Y109F)	
	Internal relay (R) (note 2)	4096 (R0 - R255F) or 8192 points (R0 - R511F)	
	Link relay (L)	2048 points (L0 - L127F)	
	Timer / counter (T/C) (note 3)	Measures 1024 points (1008 points for the timer: T0 - T1007, 16 points for the counter: C1008 - C1023) timer (1msec / 10msec / 100msec / 1sec unit) x 32767 measures counter 1 - 32767	
	Special internal relay (R)	256 points (R9000 - R915F)	
Storage region	External input (WX)	110 words (WX0 - WX109)	
	External output (WY)	110 words (WY0 - WY109)	
	Internal relay (WR)	256 words (WR0 - WR255) or 512 words (WR0 - WR511) (note 2)	
	Link relay (WL)	128 words (WL0 - WL127)	
	Data register (DT)	C14:	12285 words (DT0 - DT12284)
		C30 / C40 / C60: (note 4)	12285 words (DT0-DT12284) 32765 words (DT0-DT32764) 65533 words (DT0-DT65532)
		Special data register (DT)	500 words (DT90000 - DT90499)
	Link data register (LD)	256 characters (LD0 - LD255)	
	Timer / counter set value area (SV)	1024 words (SV0 - SV1023)	
	Timer / counter elapsed value area (EV)	1024 words (EV0 - EV1023)	
Index register (I)	14 words (I0 - ID)		
Constant	Decimal constant (K)	K-32,768 - K32,767 (16-bit operation) K-2,147,483,648 - K2,147,483,647(32-bit operation)	
	Hexadecimal constant (H)	H0-HFFFF (16-bit operation) H0-HFFFFFFF (32-bit operation)	
	Floating-point type real numbers (f)	F-1.175494×10 ⁻³⁸ - F-3.402823×10 ³⁸ F 1.175494×10 ⁻³⁸ - F 3.402823×10 ³⁸	
Position control storage		1800 words in the position control data sheet area: 20 data sheets for each channel, 250 words	

(Note 1): The number of points in the above table is the point number of the operational storage. The actual number of points is determined by the combination of hardware.

(Note 2): It can be selected by the capacity of the system register No. 1 internal relay. When it is required to be compatible with the old model FP-X series control unit, choose 4096 points.

(Note 3): The number of timer points can be changed by the setting of the system register No. 5.

(Note 4): When changing the system register No.0 (sequence program capacity), the data register (DT) capacity will also change.

Program capacity	24K	32K	40K
Data register capacity	65533 words	32765 words	12285 words

(Note 5): For details on hold / non-hold area, refer to 6.1 Storage Backup.

(Note 6): For details about the position control storage, refer to "FP-XH User Manual (Position Control / PWM Output Function)."

11.3 System Register List

	No.	Name	Initial value	Set value range and description	
Memory allocation	0	Sequential control program area capacity setting	16	C14: 16k words (fixed)	
			32	C30 / C40 / C60: 24, 32, 40 k words (note 1) (note 2)	
	1	Internal relay capacity	8192	4096,8192 (note 3)	
Hold / non-hold 1	5	Counter starting number	1008	0 - 1024	
	6	Timer / counter hold area starting number	1008	0 - 1024	
	7	Internal relay hold area starting number	504	0 - 512	
	8	Data register hold area starting number	C14:12230 C30C40 C60: 32450	0 - 65533	(Note 2) (Note 4)
	14	Selection of hold / non-hold in the step ladder diagram program	Non-hold	Hold / non-hold	
4	The differential rising edge execution instruction in MC is detected, hold the previous value	Hold	Hold / non-hold		
Hold / non-hold 2	10	Link relay for PC (PLC) link W0-0 Hold area starting word number	64	0 - 64	
	11	Link relay for PC (PLC) link W0-1 Hold area starting word number	128	64 - 128	
	12	Link register for PC (PLC) link W0-0 Hold area starting number	128	0 - 128	
	13	Link register for PC (PLC) link W0-1 Hold area starting number	256	128 - 256	
Operate during abnormality	20	Selection of dual output (disable / enable)	Disable	Disable / enable	
	23	Selection of operation mode in case of I/O check exception (stop / run)	Stop	Stop / run	
	25	Selection of operation mode in case of position control error (stop / run)	Run	Run / stop	
	26	Selection of operation mode in case of operational error (stop / run)	Stop	Stop / run	
	4	Selection of operation mode in case of battery error	Not execute	Not execute: Do not notify the self-diagnostic error when the battery is abnormal, the ERR.LED does not flash. Execute: Do not notify the self-diagnostic error when the battery is abnormal, the ERR.LED flashes.	

(Note 1): The system register No. 0 can be set only when editing offline: sequential control program area capacity setting. To set the content effectively, you need to download it to the control unit controller.

(Note 2): If you change the system register No. 0: sequential control program area capacity setting, the capacity of the data register DT will be changed.

(Note 3): The system register No. 1: if the internal relay capacity is required to compatible with the hold area when the older model FP-X control unit kept powered down, select "4096" spot.

(Note 4): The data within the setting range of the register can be kept only when equipped with the optional battery. Use the initial values directly when the battery is not installed.

	No.	Name	Initial value	Set value range and description
Time setting	31	Multi-frame processing waiting time	6500.0 ms	10 - 81900 ms (2.5 ms unit)
	32	Timeout time for SEND / RECV, RMRD / RMWT instructions	10000.0 ms	10 - 81900 ms (2.5 ms unit)
	34	Constant scanning time	Normal scanning	0: normal scanning (0.5 ms unit) 0 - 350 ms: scan once at a specified time interval
	36	Expansion unit recognition time	0	0 - 10 seconds (unit: 0.1 seconds) 0: no waiting time
	37	Task time priority setting	Standard	Standard / operation
PC link W0-0 setting	40	Usage range of the link relay	0	0 - 64 words
	41	Usage range of the link register	0	0 - 128 words
	42	Starting word number sent by the link relay	0	0 - 63
	43	Link relay sending capacity	0	0 - 64 words
	44	Starting number sent by the link register	0	0 - 127
	45	Link register sending capacity	0	0 - 127 words
	46	PC (PLC) link switching flag	Standard	Normal / reverse
	47	MEWNET-W0 PC (PLC) link maximum station number assignment	16	1 - 16
	48	PLC link communication speed (note 2)	115200 bps	115200 bps / 230400 bps
PC link W0-1 setting	50	Usage range of the link relay	0	0 - 64 words
	51	Usage range of the link register	0	0 - 128 words
	52	Starting word number sent by the link relay	64	64 - 127
	53	Link relay sending capacity	0	0 - 64 words
	54	Starting number sent by the link register	128	128 - 255
	55	Link register sending capacity	0	0 - 127 words
	57	MEWNET-W0 PC (PLC) link maximum station number assignment	16	1 - 16

(Note 1): When the system register No. 37 task time is set as "Operation" preferentially, after every scan, the time required for the communication process is reduced to 1 port, the operation processing has priority.

(Note 2): The system register No. 48 PLC link communication speed is set in the same dialog box that the COM0 port and COM1 port setting used.

■ FP-XH transistor type

	No.	Name	Initial value	Set value range and description
Master input setting 1 (HSC)	400	High-speed counter settings (X0-X3)	CH0: X0 is not set as a high speed counter	X0 is not set as a high speed counter addition input (X0) subtraction input (X0) 2-phase input (X0, X1) individual input (X0, X1) direction identification (X0, X1)
			X0: General input	General input Pulse output CH0 J point position control input starts
			CH:1 X1 is not set as a high speed counter	X1 is not set as a high speed counter addition input (X1) subtraction input (X1)
			X1: General input	General input Pulse output CH1 J point position control input starts
			CH2: X2 is not set as a high speed counter	X2 is not set as a high speed counter addition input (X2) subtraction input (X2) 2-phase input (X2, X3) individual input (X2, X3) direction identification (X2, X3)
			X2: General input	General input Origin input of the pulse output CH4 (C60 only)
			CH3: X3 is not set as a high speed counter	X3 is not set as a high speed counter addition input (X3) subtraction input (X3)
			X3: General input	General input Origin input of the pulse output CH5 (C60 only)

- (Note 1): When the high-speed counter CH0, CH2, CH4 and CH6 are set to one of 2-phase, alone and direction identification, the setting of CH1, CH3, CH5 and CH7 are invalid.
- (Note 2): The high-speed counter hardware reset input can only use CH0 and CH2. X6 and X7 can be allocated for CH0 and CH2 respectively.
- (Note 3): When the same input is set to one of high-speed counter, pulse catch and interrupt input, the priority order is high-speed counter → pulse catch → interrupt input.

	No.	Name	Initial value	Set value range and description
Master input setting 2 (HSC / PLS)	401	High speed counter output pulse setting (X4-X7)	CH4: X4 is not set as a high speed counter	X4 is not set as a high speed counter addition input (X4) subtraction input (X4) 2-phase input (X4, X5) individual input (X4, X5) direction identification (X4, X5)
			X4: General input	General input Origin input of the pulse output CH0
			CH5: X5 is not set as a high speed counter	X5 is not set as a high speed counter addition input (X5) subtraction input (X5)
			X5: General input	General input Origin input of the pulse output CH1
			CH6: X6 is not set as a high speed counter	X6 is not set as a high speed counter addition input (X6) subtraction input (X6) 2-phase input (X6, X7) individual input (X6, X7) direction identification (X6, X7)
			X6: General input	General input Origin input of the pulse output CH2 Reset input of the high speed counter CH0
			CH7: X7 is not set as a high speed counter	X7 is not set as a high speed counter addition input (X7) subtraction input (X7)
			X7: General input	General input Origin input of the pulse output CH3 Reset input of the high speed counter CH2

(Note 1): When the high-speed counter CH0, CH2, CH4 and CH6 are set to one of 2-phase, alone and direction identification, the setting of CH1, CH3, CH5 and CH7 are invalid.

(Note 2): The high-speed counter hardware reset input can only use CH0 and CH2. X6 and X7 can be allocated for CH0 and CH2 respectively.

(Note 3): When the same input is set to one of high-speed counter, pulse catch and interrupt input, the priority order is high-speed counter → pulse catch → interrupt input.

(Note 4): X4 - X7 can also be used as a origin input of the pulse output CH0 - CH3. When using the origin input through the pulse output origin return function, please select it. In this case, X4 - X7 can not be set as a high speed counter.

■ FP-XH transistor type

	No.	Name	Initial value	Set value range and description																																
Master output setting 2 (PLS / PWM)	407	Position control start setting	Data sheet setting mode	Data sheet setting mode FP-X compatible instruction mode.																																
	402	Pulse-PWM output setting (Y0-YB)	CH0:	Normal output (Y0, Y1)	Typical output (Y0, Y1) PWM output (Y0), typical output (Y1) pulse output [data sheet setting mode (Y0, Y1) pulse output (Y0, Y1)																															
			CH1:	Normal output (Y2, Y3)	Typical output (Y2, Y3) PWM output (Y2), typical output (Y3) pulse output [data sheet setting mode (Y2, Y3) pulse output (Y2, Y3)																															
			CH2:	Normal output (Y4, Y5)	Typical output (Y4, Y5) PWM output (Y4), typical output (Y5) pulse output [data sheet setting mode (Y4, Y5) pulse output (Y4, Y5)																															
			CH3:	Normal output (Y6, Y7)	Typical output (Y6, Y7) PWM output (Y6), typical output (Y7) pulse output [data sheet setting mode (Y6, Y7) pulse output (Y0, Y1)																															
			CH4:	Normal output (Y8, Y9)	Typical output (Y8, Y9) pulse output [data sheet setting mode (Y8, Y9) pulse output (Y8, Y9)																															
CH5:	Normal output (YA, YB)	Typical output (YA, YB) pulse output (YA, YB) PWM output (YA), typical output (YB)																																		
Interrupt / pulse catch setting	403	Pulse catch input setting	Do not set	<table border="1" style="margin-left: auto; margin-right: auto;"> <tr> <td>X0</td><td>X1</td><td>X2</td><td>X3</td><td>X4</td><td>X5</td><td>X6</td><td>X7</td> </tr> <tr> <td><input type="checkbox"/></td><td><input type="checkbox"/></td><td><input type="checkbox"/></td><td><input type="checkbox"/></td><td><input type="checkbox"/></td><td><input type="checkbox"/></td><td><input type="checkbox"/></td><td><input type="checkbox"/></td> </tr> </table> Mainframe input The contact pressed is set as pulse catch input.	X0	X1	X2	X3	X4	X5	X6	X7	<input type="checkbox"/>	<input type="checkbox"/>	<input type="checkbox"/>	<input type="checkbox"/>	<input type="checkbox"/>	<input type="checkbox"/>	<input type="checkbox"/>	<input type="checkbox"/>																
	X0	X1	X2	X3	X4	X5	X6	X7																												
<input type="checkbox"/>	<input type="checkbox"/>	<input type="checkbox"/>	<input type="checkbox"/>	<input type="checkbox"/>	<input type="checkbox"/>	<input type="checkbox"/>	<input type="checkbox"/>																													
404	Interrupt input setting	Do not set	<table border="1" style="margin-left: auto; margin-right: auto;"> <tr> <td>X0</td><td>X1</td><td>X2</td><td>X3</td><td>X4</td><td>X5</td><td>X6</td><td>X7</td> </tr> <tr> <td><input type="checkbox"/></td><td><input type="checkbox"/></td><td><input type="checkbox"/></td><td><input type="checkbox"/></td><td><input type="checkbox"/></td><td><input type="checkbox"/></td><td><input type="checkbox"/></td><td><input type="checkbox"/></td> </tr> </table> Mainframe input The contact pressed is set as pulse catch input.	X0	X1	X2	X3	X4	X5	X6	X7	<input type="checkbox"/>	<input type="checkbox"/>	<input type="checkbox"/>	<input type="checkbox"/>	<input type="checkbox"/>	<input type="checkbox"/>	<input type="checkbox"/>	<input type="checkbox"/>																	
X0	X1	X2	X3	X4	X5	X6	X7																													
<input type="checkbox"/>	<input type="checkbox"/>	<input type="checkbox"/>	<input type="checkbox"/>	<input type="checkbox"/>	<input type="checkbox"/>	<input type="checkbox"/>	<input type="checkbox"/>																													
Interrupt pulse edge setting	405	Interrupt input pulse setting	Rising edge	<table border="1" style="margin-left: auto; margin-right: auto;"> <tr> <td>X0</td><td>X1</td><td>X2</td><td>X3</td><td>X4</td><td>X5</td><td>X6</td><td>X7</td> </tr> <tr> <td><input type="checkbox"/></td><td><input type="checkbox"/></td><td><input type="checkbox"/></td><td><input type="checkbox"/></td><td><input type="checkbox"/></td><td><input type="checkbox"/></td><td><input type="checkbox"/></td><td><input type="checkbox"/></td> </tr> </table> Pulse rising edge <table border="1" style="margin-left: auto; margin-right: auto;"> <tr> <td>X0</td><td>X1</td><td>X2</td><td>X3</td><td>X4</td><td>X5</td><td>X6</td><td>X7</td> </tr> <tr> <td><input type="checkbox"/></td><td><input type="checkbox"/></td><td><input type="checkbox"/></td><td><input type="checkbox"/></td><td><input type="checkbox"/></td><td><input type="checkbox"/></td><td><input type="checkbox"/></td><td><input type="checkbox"/></td> </tr> </table> Pulse falling edge The contact pressed is set as rising edge and falling edge.	X0	X1	X2	X3	X4	X5	X6	X7	<input type="checkbox"/>	<input type="checkbox"/>	<input type="checkbox"/>	<input type="checkbox"/>	<input type="checkbox"/>	<input type="checkbox"/>	<input type="checkbox"/>	<input type="checkbox"/>	X0	X1	X2	X3	X4	X5	X6	X7	<input type="checkbox"/>	<input type="checkbox"/>	<input type="checkbox"/>	<input type="checkbox"/>	<input type="checkbox"/>	<input type="checkbox"/>	<input type="checkbox"/>	<input type="checkbox"/>
X0	X1	X2	X3	X4	X5	X6	X7																													
<input type="checkbox"/>	<input type="checkbox"/>	<input type="checkbox"/>	<input type="checkbox"/>	<input type="checkbox"/>	<input type="checkbox"/>	<input type="checkbox"/>	<input type="checkbox"/>																													
X0	X1	X2	X3	X4	X5	X6	X7																													
<input type="checkbox"/>	<input type="checkbox"/>	<input type="checkbox"/>	<input type="checkbox"/>	<input type="checkbox"/>	<input type="checkbox"/>	<input type="checkbox"/>	<input type="checkbox"/>																													

(Note 1): If changes No.407: position control starts as set, No.402: The PWM pulse output setting selection item will be switched.

(Note 2): When using the pulse output [data sheet setting mode], pulse output and PWM output function, the controller output must be set. In addition, the output set in the pulse output and PWM output can not be used as a normal output.

(Note 3): When the same input is set to one of high-speed counter, pulse catch and interrupt input, the priority order is high-speed counter → pulse catch → interrupt input.

■ FP-XH relay type

	No.	Name	Initial value	Set value range and description
Pulse input and output card setting (HSC / PLS)	407	Position control start setting	Data sheet setting mode	Data sheet setting mode FP-X compatible instruction mode.
	400	High speed counter settings (X100-X102)	CH8: X00 is not set as a high speed counter	X00 is not set as a high speed counter 2 phase input (X100, X101) 2 phase input (X100, X101) Reset input (X102) addition input (X100) addition input (X100) Reset input (X102) subtraction input (X100) subtraction input (X100) Reset input (X102) individual input (X100, X101) individual input (X100, X101) Reset input (X102) direction identification (X100, X101) direction identification (X100, X101) Reset input (X102)
			X100: General input	General input Pulse output CH0 J point position control input starts
			CH9: X101 is not set as a high speed counter	X101 is not set as a high speed counter Addition input (X101) addition input (X101) Reset input (X102) subtraction input (X101) subtraction input (X101) Reset input (X102)
		Pulse output setting (Y100-Y101)	CH0: Typical output	Typical output (Y100, Y101) pulse output [data sheet setting mode (Y100, Y101) pulse output (Y100, Y101) PWM output (Y100), typical output (Y101)

- (Note 1): If changes No.407: position control starts as set, No.402: The PWM pulse output setting selection item will be switched.
- (Note 2): When the operation mode is set to one of 2-phase, alone and direction identification, the CH9 setting in the system register No. 400 is invalid.
- (Note 3): When the reset input setting is repeated, the CH9 setting in the system register No. 400 has priority.
- (Note 4): If the operation mode of the pulse output CH0 and CH1 is set, it can not be used as a normal output. If the operation mode of the pulse output CH0 is set to 1, the reset input of the high speed counter CH8 and CH9 is invalid.
- (Note 5): When using the pulse output [data sheet setting mode], pulse output and PWM output function, the controller output must be set. In addition, the output set in the pulse output and PWM output can not be used as a normal output.

	No.	Name	Initial value	Set value range and description
Pulse input and output card setting (HSC / PLS)	401	High speed counter settings (X200-X202)	CHA: X200 is not set as a high speed counter	X200 is not set as a high speed counter 2 phase input (X200, X201) 2 phase input (X200, X201) Reset input (X202) addition input (X200) addition input (X200) Reset input (X202) subtraction input (X200) subtraction input (X200) Reset input (X202) individual input (X200, X201) individual input (X200, X201) Reset input (X202) direction identification (X200, X201) direction identification (X200, X201) Reset input (X202)
			X200: General input	General input Pulse output CH1 J point position control input starts
			CHB: X201 is not set as a high speed counter	X201 is not set as a high speed counter Addition input (X201) addition input (X201) Reset input (X202) subtraction input (X201) subtraction input (X201) Reset input (X202)
	Pulse output setting (Y200-Y201)	CH1: Typical output	Typical output (Y200, Y201) pulse output [data sheet setting mode (Y200, Y201) pulse output (Y200, Y201) PWM output (Y200), typical output (Y201)	

- (Note 1): If changes No.407: position control starts as set, No.402: The PWM pulse output setting selection item will be switched.
- (Note 2): When the operation mode is set to one of 2-phase, alone and direction identification, the CHB setting in the system register No. 401 is invalid.
- (Note 3): When the reset input setting is repeated, the CH9 setting in the system register No. 400 has priority; the CHB setting in the No. 401 has priority.
- (Note 4): The CHA, CHB and CH1 input signal in No. 401 refers to the signal when the pulse input and output card (AFPX-PLS) is mounted on the card installation part 2.
- (Note 5): If the operation mode of the pulse output CH1 is set, it can not be used as a normal output. If the operation mode of the pulse output CH1 is set to 1, the reset input of the high speed counter CHB is invalid.
- (Note 6): When using the pulse output [data sheet setting mode], pulse output and PWM output function, the controller output must be set. In addition, the output set in the pulse output and PWM output can not be used as a normal output.

■ FP-XH relay type

	No.	Name	Initial value	Set value range and description
Master input setting (HSC)	402	High-speed counter settings (X0-X7)	CH0: X0 is not set as a high speed counter	X0 is not set as a high speed counter addition input (X0) subtraction input (X0) 2-phase input (X0, X1)
			CH1: X1 is not set as a high speed counter	X1 is not set as a high speed counter addition input (X1) subtraction input (X1) 2-phase input (X0, X1)
			CH2: X2 is not set as a high speed counter	X2 is not set as a high speed counter addition input (X2) subtraction input (X2) 2-phase input (X2, X3)
			CH3: X3 is not set as a high speed counter	X3 is not set as a high speed counter addition input (X3) subtraction input (X3) 2-phase input (X2, X3)
			CH4: X4 is not set as a high speed counter	X4 is not set as a high speed counter addition input (X4) subtraction input (X4) 2-phase input (X4, X5)
			CH5: X5 is not set as a high speed counter	X5 is not set as a high speed counter addition input (X5) subtraction input (X5) 2-phase input (X4, X5)
			CH6: X6 is not set as a high speed counter	X6 is not set as a high speed counter addition input (X6) subtraction input (X6) 2-phase input (X6, X7)
			CH7: X7 is not set as a high speed counter	X7 is not set as a high speed counter addition input (X7) subtraction input (X7) 2-phase input (X6, X7)

(Note 1): When counting 2-phase input, use only CH0, CH2, CH4 and CH6. When specifying the 2-phase input in CH0, CH2, CH4 and CH6, the CH1, CH3, CH5 and CH7 settings corresponding to each CH number are ignored, please set it as the same.

(Note 2): For the same input contact, when setting No. 400 - No. 404 at the same time, the priority order is high-speed counter → pulse catch → interrupt input.
 <Example> When using the high speed counter in the addition input mode, X0 is valid as a counter input of the high speed counter, even if X0 is specified as an interrupt input or pulse catch input.

	No.	Name	Initial value	Set value range and description																				
Interrupt / pulse catch setting	403	Pulse catch input setting	Do not set	<table border="1"> <tr> <td>Mainframe input</td> <td>X0</td><td>X1</td><td>X2</td><td>X3</td><td>X4</td><td>X5</td><td>X6</td><td>X7</td> </tr> <tr> <td>Pulse input and output card</td> <td>X100</td><td>X101</td><td>X102</td><td>X200</td><td>X201</td><td>X202</td> <td colspan="3"></td> </tr> </table> <p>The contact pressed is set as pulse catch input.</p>	Mainframe input	X0	X1	X2	X3	X4	X5	X6	X7	Pulse input and output card	X100	X101	X102	X200	X201	X202				
	Mainframe input	X0	X1	X2	X3	X4	X5	X6	X7															
Pulse input and output card	X100	X101	X102	X200	X201	X202																		
404	Interrupt input setting	Do not set	<table border="1"> <tr> <td>Mainframe input</td> <td>X0</td><td>X1</td><td>X2</td><td>X3</td><td>X4</td><td>X5</td><td>X6</td><td>X7</td> </tr> <tr> <td>Pulse input and output card</td> <td>X100</td><td>X101</td><td>X102</td><td>X200</td><td>X201</td><td>X202</td> <td colspan="3"></td> </tr> </table> <p>The contact pressed is set as interrupt input.</p>	Mainframe input	X0	X1	X2	X3	X4	X5	X6	X7	Pulse input and output card	X100	X101	X102	X200	X201	X202					
Mainframe input	X0	X1	X2	X3	X4	X5	X6	X7																
Pulse input and output card	X100	X101	X102	X200	X201	X202																		
Interrupt pulse edge setting	405	Master input interrupt pulse edge setting	Rising edge	<table border="1"> <tr> <td>Pulse rising edge</td> <td>X100</td><td>X101</td><td>X102</td><td>X200</td><td>X201</td><td>X202</td> <td colspan="3"></td> </tr> <tr> <td>Pulse falling edge</td> <td>X100</td><td>X101</td><td>X102</td><td>X200</td><td>X201</td><td>X202</td> <td colspan="3"></td> </tr> </table> <p>The contact pressed is set as rising edge and falling edge.</p>	Pulse rising edge	X100	X101	X102	X200	X201	X202				Pulse falling edge	X100	X101	X102	X200	X201	X202			
	Pulse rising edge	X100	X101	X102	X200	X201	X202																	
Pulse falling edge	X100	X101	X102	X200	X201	X202																		
406	Pulse input and output card interrupt pulse edge setting	Rising edge	<table border="1"> <tr> <td>Pulse rising edge</td> <td>X100</td><td>X101</td><td>X102</td><td>X200</td><td>X201</td><td>X202</td> <td colspan="3"></td> </tr> <tr> <td>Pulse falling edge</td> <td>X100</td><td>X101</td><td>X102</td><td>X200</td><td>X201</td><td>X202</td> <td colspan="3"></td> </tr> </table> <p>The contact pressed is set as rising edge and falling edge.</p>	Pulse rising edge	X100	X101	X102	X200	X201	X202				Pulse falling edge	X100	X101	X102	X200	X201	X202				
Pulse rising edge	X100	X101	X102	X200	X201	X202																		
Pulse falling edge	X100	X101	X102	X200	X201	X202																		

- (Note 1): When counting 2-phase input, use only CH0, CH2, CH4 and CH6. When specifying the 2-phase input in CH0, CH2, CH4 and CH6, the CH1, CH3, CH5 and CH7 settings corresponding to each CH number are ignored, please set it as the same.
- (Note 2): Set No. 403 - 406 according to each contact on the screen.
- (Note 3): For the same input contact, when setting No. 400 - No. 404 at the same time, the priority order is high-speed counter → pulse catch → interrupt input.
 <Example> When using the high speed counter in the addition input mode, X0 is valid as a counter input of the high speed counter, even if X0 is specified as an interrupt input or pulse catch input.

	No.	Name	Initial value	Set value range and description
COM0 / COM1 / COM2 / COM3 port setting	410 411	Unit number	1	1 - 99
	412	Communication mode	Computer link	Computer link universal communication PC (PLC) link MODBUS RTU
		Selection of the modem connection	Not execute	Conduct/ not conduct
	413 414	Transmission format	Data length: 8 bit Parity: odd Stop bit: 1 bit	Data length: 7 bit / 8 bit Parity: none / odd / even Stop bit: 1 / 2 End character option: code / time Terminal code: CR / CR+LF / none Start character: STX none / STX has
	415	Rate setting	9600 bps	2400 bps, 4800 bps, 9600 bps, 19200 bps 38400 bps, 57600 bps, 115200 bps, 230400 bps
	416	(COM1) general communication receive buffer starting address	0	0 - 65532
	417	(COM1) general communication receive buffer capacity	2048	0 - 2048
	418	(COM2) general communication receive buffer starting address	2048	0 - 65532
	419	(COM2) general communication receive buffer capacity	2048	0 - 2048
	420	(COM0) general communication receive buffer starting number	4096	0 - 65532
	421	(COM0) general communication receive buffer capacity	2048	0 - 2048
	422	(COM3) general communication receive buffer starting address	6144	0 - 65532
	423	(COM3) general communication receive buffer capacity	2048	0 - 2048
	424	(COM0) Terminal judgment time (x0.01ms)	0	0 - 10000
	425	(COM1) Terminal judgment time (x0.01ms)	0	0 - 10000
	426	(COM2) Terminal judgment time (x0.01ms)	0	0 - 10000
	427	(COM3) Terminal judgment time (x0.01ms)	0	0 - 10000

(Note 1): Select No. 412: when you select a computer link or MODBUS RTU in the communication mode, the No. 413 transmission format and No. 415 communication speed can be set.

(Note 2): Select No. 412: when selecting only the universal communication in the communication mode, you can set No. 413: transmission format terminal selection, terminal code and start character. In addition, when selecting the terminal as time only through No. 413, you can select No. 420 - No. 427.

(Note 3): The PC (PLC) link function is only available for COM0 or COM1 port. Data length for transmission format: 8 bits, Parity: odd, stop bit: fixed to 1 In addition, select the communication speed in PC link W0-0 system register No. 48 item.

Specification

	No.	Name	Initial value	Set value range and description
Constant setting for controller input	430	Master input constant setting 1 X0-X3	No	No 1 ms 2 ms 4 ms 8 ms 16 ms 32 ms 64 ms 128 ms 256 ms
	431	Master input constant setting 1 X4-X7		
	432	Master input time constant setting 2 X8-XB		
	433	Master input time constant setting 2 XC-XF		
	434	Master input time constant setting 3 X10-X13		
	435	Master input time constant setting 3 X14-X17		
	436	Master input time constant setting 4 X18-X1B		
	437	Master input time constant setting 4 X1C-X1F		

11.4 Special Relay List



WR900 (specified in word)

Relay number	Name	Contents
R9000	Self-diagnostic error flag	When an error flag self-diagnostic error occurs, it is ON. → Self-diagnostic result stored in DT90000.
R9001	Unused	
R9002	Function card I/O error flag	When an abnormality is detected in the input and output card, it is ON.
R9003	Function card exception flag	When an abnormality is detected in the function card, it is ON.
R9004	I/O check error flag	When a I/O check error is detected, it is ON.
R9005	Backup battery error flag (current type)	When a battery error is detected, it turns to ON. Even if you choose not to notify battery error in the system register, it is also ON when the battery runs out.
R9006	Backup battery error flag (hold)	When a battery error is detected, it turns to ON. Even if you choose not to notify battery error in the system register, it is also ON when the battery runs out. When a battery error is detected, it is maintained after the reset. → If you turn off the power or perform initialization operation, it turns to OFF.
R9007	Operation error flag (hold) (ER flag)	When you start running, it is ON if an error occurs, and it is maintained during operation. → The address where an error occurred stored in DT90017. (Display the operation error occurred initially.)
R9008	Operation error flag (latest) (ER flag)	It is ON whenever an operation error occurs. → The address where an error occurred stored in DT90018. Every time a new error occurs, the content will be updated.
R9009	Carry flag (CY flag)	When the operation result overflows or underflows, or when performing the result of the shift system instruction, the flag resets.
R900A	> Flag	Execute comparison instruction, if the comparison result is large, it is ON.
R900B	= Flag	Execute comparison instruction, if the comparison result is equal, it is ON. Execute operation instruction, if the comparison result is 0, it is ON.
R900C	< Flag	Execute comparison instruction, if the comparison result is small, it is ON.
R900D	Auxiliary timer contact	Execute auxiliary timing instruction (F137 / F138), it turns to ON after a set time. If the execution condition turns to OFF, the flag is OFF.
R900E (R9130)	COM0 port communication error	When using COM0 port, if it detects a communication error, it is ON.
R900F	Constant scan error flag	When performing constant scanning, if the scan time exceeds the value of the set timer (system register No. 34), it is ON. In the system register No. 34, it also turns to ON when 0 is set.

(Note 1): The special internal relay in parentheses is also allocated the same function.

Specification

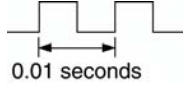
WR9001 (specified in word)

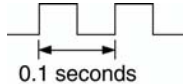
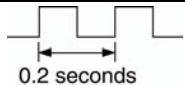
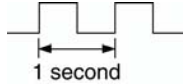
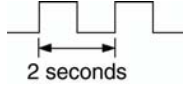
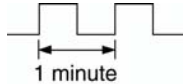
Relay number	Name	Contents	
R9010	NO relay	Always in the ON state.	
R9011	NC relay	Always in the OFF state.	
R9012	Scan pulse relay	Each scan cycle repeats ON / OFF action.	
R9013	Initial pulse relay (ON)	Only ON at the first scan cycle after the run (RUN), turns to OFF from the second scan cycle.	
R9014	Initial pulse relay (OFF)	Only OFF at the first scan cycle after the run (RUN), turns to ON from the second scan cycle.	
R9015	Step ladder diagram initial pulse relay (ON)	When performing step ladder diagram control, it is ON only at the first scan cycle after a progress starts.	
R9016	Unused		
R9017	Unused		
R9018	0.01 seconds clock pulse relay	The clock pulse with a cycle of 0.01 seconds.	
R9019	0.02 seconds clock pulse relay	The clock pulse with a cycle of 0.02 seconds.	
R901A	0.1 seconds clock pulse relay	The clock pulse with a cycle of 0.1 seconds.	
R901B	0.2 seconds clock pulse relay	The clock pulse with a cycle of 0.2 seconds.	
R901C	1 seconds clock pulse relay	The clock pulse with a cycle of 1 seconds.	
R901D	2 seconds clock pulse relay	The clock pulse with a cycle of 2 seconds.	
R901E	1 min clock pulse relay	The clock pulse with a cycle of 1 minute.	
R901F	Unused		

WR902 (specified in word)

Relay number	Name	Contents
R9020	RUN mode flag	If you switch to PROG. mode, it is OFF. If you switch to RUN mode, it is ON.
R9021	Unused	
R9022	Unused	
R9023	Unused	
R9024	Unused	
R9025	Unused	
R9026	There are information sign	If you execute the information display instruction (F149), it is ON.
R9027	Unused	
R9028	Unused	
R9029	Force flag	When performing force ON / OFF for the input / output relay, timer / counter contacts, it is ON.
R902A	Interrupt flag	When an external interrupt is permitted, it is ON.
R902B	Interrupt exception flag	When an interrupt exception occurs, it is ON.
R902C	Sampling point mark	Sample according to instructions: 0, sample at certain interval: 1
R902D	Sampling and tracking completed flag	When the sampling operation stops: 1, starts: 0
R902E	Sample stop trigger flag	When the sample stop trigger starts: 1, stops: 0
R902F	Sampling permission flag	Sampling starts: 1, stops: 0

Specification

WR903 (specified in word)

Relay number	Name	Contents
R9030	Unused	
R9031	Unused	
R9032 (R9139)	COM1 port operation mode flag	When using the general communication function, it is ON. When using a function outside of the general communication function, it is OFF.
R9033	Print instruction executing flag	OFF: not executed. ON: executing
R9034	Program editing flag in RUN mode	The special internal relay that is ON only at the first scan cycle after program editing completed in RUN mode.
R9035	Unused	
R9036	Unused	
R9037 (R9138)	COM1 port communication error flag	When perform data communication, if a transmission error occurs, it is ON. When executing F159 (MTRN) instruction, if transmitting is required, it is OFF.
R9038 (R913A)	Reception completion flag for COM1 port general communication	For general communication, if the terminal code is received, it is ON.
R9039 (R913B)	Transmission completion flag for COM1 port general communication	For general communication, if end the transmission, it is ON. For general communication, if transmitting is required, it is OFF.
R903A	Unused	
R903B	Unused	
R903C	Unused	
R903D	Unused	
R903E (R9132)	Reception completion flag for COM0 port general communication	For general communication, if the terminal code is received, it is ON.
R903F (R9133)	Transmission completion flag for COM0 port general communication	For general communication, if end the transmission, it is ON. For general communication, if transmitting is required, it is OFF.

(Note 1): R9030 - R903F will change even during one scanning cycle. In addition, the special internal relay in parentheses is also allocated the same function.

WR904 (specified in word)

Relay number	Name	Contents
R9040 (R9131)	COM0 port operation mode flag	When using the general communication function, it is ON. When using a function outside of the general communication function, it is OFF.
R9041 (R913E)	COM1 port PC (PLC) link flag	When using the PC (PLC) link function, it is ON.
R9042 (R9141)	COM2 port operation mode flag	When using the general communication function, it is ON. When using a function outside of the general communication function, it is OFF.
R9043	Unused	
R9044 (R913C)	COM1 port SEND / RECV command executable flag	Indicates the instruction with respect to the F145 (SEND) or F146 (RECV) instruction of the COM1 port is executable / non-executable. OFF: non-executable (instruction executing) ON: executable
R9045 (R913D)	COM1 port SEND / RECV command execution completion Flag	Indicates the status with respect to the F145 (SEND) or F146 (RECV) instruction of the COM1 port. OFF: normal completion ON: abnormal completion (a communication error occurs) The error code is stored to DT90124.
R9046	Unused	
R9047 (R9140)	COM2 port communication error flag	When perform data communication, if a transmission error occurs, it is ON. When executing F159 (MTRN) instruction, if transmitting is required, it is OFF.
R9048 (R9142)	Reception completion flag for COM2 port general communication	For general communication, if the terminal code is received, it is ON.
R9049 (R9143)	Transmission completion flag for COM2 port general communication	For general communication, if end the transmission, it is ON. For general communication, if transmitting is required, it is OFF.
R904A (R9144)	COM2 port SEND / RECV command execution completion Flag	Indicates the instruction with respect to the F145 (SEND) or F146 (RECV) instruction of the COM2 port is executable / non-executable. OFF: non-executable (instruction executing) ON: executable
R904B (R9145)	COM2 port SEND / RECV command execution completion flag	Indicates the status with respect to the F145 (SEND) or F146 (RECV) instruction of the COM2 port. OFF: normal completion ON: abnormal completion (a communication error occurs) The error code is stored to DT90125.
R904C- R904F	Unused	

(Note 1): R9040 - R904F will change even during a scanning cycle. In addition, the special internal relay in parentheses is also allocated the same function.

WR905 (specified in word)

Relay number	Name	Contents
R9050	MEWNET-W0 PC (PLC) link transmission error flag	When using MEWNET-W0 When a transmission error sent through the PC (PLC) link, it is ON. When the setting of the PC (PLC) link area is abnormal, it is ON.
R9051- R905F	Unused	

Specification

WR906 (specified in word)

Relay number	Name	Contents
R9060	MEWNET-W0 PC (PLC) link 0 transmit guarantee relay	Unit No.1 For normal communication in the PC (PLC) link mode: ON When stopping, error occurs or PC (PLC) is not linked: OFF
R9061		Unit No.2 For normal communication in the PC (PLC) link mode: ON When stopping, error occurs or PC (PLC) is not linked: OFF
R9062		Unit No.3 For normal communication in the PC (PLC) link mode: ON When stopping, error occurs or PC (PLC) is not linked: OFF
R9063		Unit No.4 For normal communication in the PC (PLC) link mode: ON When stopping, error occurs or PC (PLC) is not linked: OFF
R9064		Unit No.5 For normal communication in the PC (PLC) link mode: ON When stopping, error occurs or PC (PLC) is not linked: OFF
R9065		Unit No.6 For normal communication in the PC (PLC) link mode: ON When stopping, error occurs or PC (PLC) is not linked: OFF
R9066		Unit No.7 For normal communication in the PC (PLC) link mode: ON When stopping, error occurs or PC (PLC) is not linked: OFF
R9067		Unit No.8 For normal communication in the PC (PLC) link mode: ON When stopping, error occurs or PC (PLC) is not linked: OFF
R9068		Unit No.9 For normal communication in the PC (PLC) link mode: ON When stopping, error occurs or PC (PLC) is not linked: OFF
R9069		Unit No.10 For normal communication in the PC (PLC) link mode: ON When stopping, error occurs or PC (PLC) is not linked: OFF
R906A		Unit No.11 For normal communication in the PC (PLC) link mode: ON When stopping, error occurs or PC (PLC) is not linked: OFF
R906B		Unit No.12 For normal communication in the PC (PLC) link mode: ON When stopping, error occurs or PC (PLC) is not linked: OFF
R906C		Unit No.13 For normal communication in the PC (PLC) link mode: ON When stopping, error occurs or PC (PLC) is not linked: OFF
R906D		Unit No.14 For normal communication in the PC (PLC) link mode: ON When stopping, error occurs or PC (PLC) is not linked: OFF
R906E		Unit No.15 For normal communication in the PC (PLC) link mode: ON When stopping, error occurs or PC (PLC) is not linked: OFF
R906F		Unit No.16 For normal communication in the PC (PLC) link mode: ON When stopping, error occurs or PC (PLC) is not linked: OFF

WR907 (specified in word)

Relay number	Name	Contents
R9070	MEWNET-W0 PC (PLC) link 0 operation mode relay	Unit No. 1 When the unit No. 1 is in RUN mode: ON. When in PROG mode: OFF.
R9071		Unit No. 2 When the unit No. 2 is in RUN mode: ON. When in PROG mode: OFF.
R9072		Unit No. 3 When the unit No. 3 is in RUN mode: ON. When in PROG mode: OFF.
R9073		Unit No. 4 When the unit No. 4 is in RUN mode: ON. When in PROG mode: OFF.
R9074		Unit No. 5 When the unit No. 5 is in RUN mode: ON. When in PROG mode: OFF.
R9075		Unit No. 6 When the unit No. 6 is in RUN mode: ON. When in PROG mode: OFF.
R9076		Unit No. 7 When the unit No. 7 is in RUN mode: ON. When in PROG mode: OFF.
R9077		Unit No. 8 When the unit No. 8 is in RUN mode: ON. When in PROG mode: OFF.
R9078		Unit No. 9 When the unit No. 9 is in RUN mode: ON. When in PROG mode: OFF.
R9079		Unit No. 10 When the unit No. 10 is in RUN mode: ON. When in PROG mode: OFF.
R907A		Unit No. 11 When the unit No. 11 is in RUN mode: ON. When in PROG mode: OFF.
R907B		Unit No. 12 When the unit No. 12 is in RUN mode: ON. When in PROG mode: OFF.
R907C		Unit No. 13 When the unit No. 13 is in RUN mode: ON. When in PROG mode: OFF.
R907D		Unit No. 14 When the unit No. 14 is in RUN mode: ON. When in PROG mode: OFF.
R907E		Unit No. 15 When the unit No. 15 is in RUN mode: ON. When in PROG mode: OFF.
R907F		Unit No. 16 When the unit No. 16 is in RUN mode: ON. When in PROG mode: OFF.

Specification

WR908 (specified in word)

Relay number	Name	Contents
R9080	MEWNET-W0 PC (PLC) link 1 transmit guarantee relay	Unit No.1 For normal communication in the PC (PLC) link mode: ON When stopping, error occurs or PC (PLC) is not linked: OFF
R9081		Unit No.2 For normal communication in the PC (PLC) link mode: ON When stopping, error occurs or PC (PLC) is not linked: OFF
R9082		Unit No.3 For normal communication in the PC (PLC) link mode: ON When stopping, error occurs or PC (PLC) is not linked: OFF
R9083		Unit No.4 For normal communication in the PC (PLC) link mode: ON When stopping, error occurs or PC (PLC) is not linked: OFF
R9084		Unit No.5 For normal communication in the PC (PLC) link mode: ON When stopping, error occurs or PC (PLC) is not linked: OFF
R9085		Unit No.6 For normal communication in the PC (PLC) link mode: ON When stopping, error occurs or PC (PLC) is not linked: OFF
R9086		Unit No.7 For normal communication in the PC (PLC) link mode: ON When stopping, error occurs or PC (PLC) is not linked: OFF
R9087		Unit No.8 For normal communication in the PC (PLC) link mode: ON When stopping, error occurs or PC (PLC) is not linked: OFF
R9088		Unit No.9 For normal communication in the PC (PLC) link mode: ON When stopping, error occurs or PC (PLC) is not linked: OFF
R9089		Unit No.10 For normal communication in the PC (PLC) link mode: ON When stopping, error occurs or PC (PLC) is not linked: OFF
R908A		Unit No.11 For normal communication in the PC (PLC) link mode: ON When stopping, error occurs or PC (PLC) is not linked: OFF
R908B		Unit No.12 For normal communication in the PC (PLC) link mode: ON When stopping, error occurs or PC (PLC) is not linked: OFF
R908C		Unit No.13 For normal communication in the PC (PLC) link mode: ON When stopping, error occurs or PC (PLC) is not linked: OFF
R908D		Unit No.14 For normal communication in the PC (PLC) link mode: ON When stopping, error occurs or PC (PLC) is not linked: OFF
R908E		Unit No.15 For normal communication in the PC (PLC) link mode: ON When stopping, error occurs or PC (PLC) is not linked: OFF
R908F		Unit No.16 For normal communication in the PC (PLC) link mode: ON When stopping, error occurs or PC (PLC) is not linked: OFF

WR909 (specified in word)

Relay number	Name	Contents
R9090	MEWNET-W0 PC (PLC) link 1 operation mode relay	Unit No. 1 When the unit No. 1 is in RUN mode: ON. When in PROG mode: OFF.
R9091		Unit No. 2 When the unit No. 2 is in RUN mode: ON. When in PROG mode: OFF.
R9092		Unit No. 3 When the unit No. 3 is in RUN mode: ON. When in PROG mode: OFF.
R9093		Unit No. 4 When the unit No. 4 is in RUN mode: ON. When in PROG mode: OFF.
R9094		Unit No. 5 When the unit No. 5 is in RUN mode: ON. When in PROG mode: OFF.
R9095		Unit No. 6 When the unit No. 6 is in RUN mode: ON. When in PROG mode: OFF.
R9096		Unit No. 7 When the unit No. 7 is in RUN mode: ON. When in PROG mode: OFF.
R9097		Unit No. 8 When the unit No. 8 is in RUN mode: ON. When in PROG mode: OFF.
R9098		Unit No. 9 When the unit No. 9 is in RUN mode: ON. When in PROG mode: OFF.
R9099		Unit No. 10 When the unit No. 10 is in RUN mode: ON. When in PROG mode: OFF.
R909A		Unit No. 11 When the unit No. 11 is in RUN mode: ON. When in PROG mode: OFF.
R909B		Unit No. 12 When the unit No. 12 is in RUN mode: ON. When in PROG mode: OFF.
R909C		Unit No. 13 When the unit No. 13 is in RUN mode: ON. When in PROG mode: OFF.
R909D		Unit No. 14 When the unit No. 14 is in RUN mode: ON. When in PROG mode: OFF.
R909E		Unit No. 15 When the unit No. 15 is in RUN mode: ON. When in PROG mode: OFF.
R909F		Unit No. 16 When the unit No. 16 is in RUN mode: ON. When in PROG mode: OFF.

Specification

WR910 - WR912 (specified in word)

Relay number	Name	Contents
R9100-R910F	Unused	
R9110	High-speed counter in-control flag	HSC-CH0
R9111		HSC-CH1
R9112		HSC-CH2
R9113		HSC-CH3
R9114		HSC-CH4
R9115		HSC-CH5
R9116		HSC-CH6
R9117		HSC-CH7
R9118		HSC-CH8
R9119		HSC-CH9
R911A		HSC-CHA
R911B		HSC-CHB
When using high-speed counter function, it is ON during the execution of F166 (HC1S) and F167 (HC1R) instructions. It is OFF when the instruction is completed. (Note 1)		
R911C	Pulse output in-control mark	PLS-CH0
R911D		PLS-CH1
R911E		PLS-CH2
R911F		PLS-CH3
R9120		PLS-CH4
R9121		PLS-CH5
When using the pulse output function or PWM output function based on the F17x instruction, start the F171 (SPDH), F172 (PLSH), F173 (PWMH), F174 (SP0H) and F175 (SPSH) instruction, it is ON during the pulse output. It is OFF when the action is completed. (Note 2)		
R9122-R912F	Unused	

(Note 1): When a pulse output card is installed only in the relay type control unit, R9118 - R911B is valid.

(Note 2): R9120 - R9121 is valid only for the transistor type control unit.

WR913 (specified in word)

Relay number	Name	Contents
R9130 (R900E)	COM0 port communication error flag	When perform data communication, if a transmission error occurs, it is ON. When executing F159 (MTRN) instruction, if transmitting is required, it is OFF.
R9131 (R9040)	COM0 port operation mode flag	When using the general communication function, it is ON. When using a function outside of the general communication function, it is OFF.
R9132 (R903E)	Reception completion flag for COM0 port general communication	For general communication, if the terminal code is received, it is ON.
R9133 (R903F)	Transmission completion flag for COM0 port general communication	For general communication, if end the transmission, it is ON. For general communication, if transmitting is required, it is OFF.
R9134	COM0 port SEND / RECV command executable flag	Indicates the instruction with respect to the F145 (SEND) or F146 (RECV) instruction of the COM0 port is executable / non-executable. OFF: non-executable (instruction executing) ON: executable
R9135	COM0 port SEND / RECV command execution completion flag	Indicates the status with respect to the F145 (SEND) or F146 (RECV) instruction of the COM0 port. OFF: normal completion ON: abnormal completion (a communication error occurs) The error code is stored to DT90123.
R9136 (R9041)	COM0 port PC (PLC) link flag	When using the PC (PLC) link function, it is ON.
R9137	Unused	
R9138 (R9037)	COM1 port communication error flag	When perform data communication, if a transmission error occurs, it is ON. When executing F159 (MTRN) instruction, if transmitting is required, it is OFF.
R9139 (R9032)	COM1 port operation mode flag	When using the general communication function, it is ON. When using a function outside of the general communication function, it is OFF.
R913A (R9038)	Reception completion flag for COM1 port general communication	For general communication, if the terminal code is received, it is ON.
R913B (R9039)	Transmission completion flag for COM1 port general communication	For general communication, if end the transmission, it is ON. For general communication, if transmitting is required, it is OFF.
R913C (R9044)	COM1 port SEND / RECV command executable flag	Indicates the instruction with respect to the F145 (SEND) or F146 (RECV) instruction of the COM1 port is executable / non-executable. OFF: non-executable (instruction executing) ON: executable
R913D (R9045)	COM1 port SEND / RECV command execution completion Flag	Indicates the status with respect to the F145 (SEND) or F146 (RECV) instruction of the COM1 port. OFF: normal completion ON: abnormal completion (a communication error occurs) The error code is stored to DT90124.
R913E (R9041)	COM1 port PC (PLC) link flag	When using the PC (PLC) link function, it is ON.
R913F	Unused	

(Note 1): R9130 - R913F will change even during one scanning cycle. In addition, it is compatible with the older model FP-X control unit, the special internal relay in parentheses also can be allocated the same function.

Specification

WR914 (specified in word)

Relay number	Name	Contents
R9140 (R9047)	COM2 port communication error flag	When perform data communication, if a transmission error occurs, it is ON. When executing F159 (MTRN) instruction, if transmitting is required, it is OFF.
R9141 (R9042)	COM2 port operation mode flag	When using the general communication function, it is ON. When using a function outside of the general communication function, it is OFF.
R9142 (R9048)	Reception completion flag for COM2 port general communication	For general communication, if the terminal code is received, it is ON.
R9143 (R9049)	Transmission completion flag for COM2 port general communication	For general communication, if end the transmission, it is ON. For general communication, if transmitting is required, it is OFF.
R9144 (R904A)	COM2 port SEND / RECV command executable flag	Indicates the instruction with respect to the F145 (SEND) or F146 (RECV) instruction of the COM2 port is executable / non-executable. OFF: non-executable (instruction executing) ON: executable
R9145 (R904B)	COM2 port SEND / RECV command execution completion flag	Indicates the status with respect to the F145 (SEND) or F146 (RECV) instruction of the COM2 port. OFF: normal completion ON: abnormal completion (a communication error occurs) The error code is stored to DT90125.
R9146	Unused	
R9147	Unused	
R9148	COM3 port communication error flag	When perform data communication, if a transmission error occurs, it is ON. When executing F159 (MTRN) instruction, if transmitting is required, it is OFF.
R9149	COM3 port operation mode flag	When using the general communication function, it is ON. When using a function outside of the general communication function, it is OFF.
R914A	Reception completion flag for COM3 port general communication	For general communication, if the terminal code is received, it is ON.
R914B	Transmission completion flag for COM3 port general communication	For general communication, if end the transmission, it is ON. For general communication, if transmitting is required, it is OFF.
R914C	COM3 port SEND / RECV command executable flag	Indicates the instruction with respect to the F145 (SEND) or F146 (RECV) instruction of the COM3 port is executable / non-executable. OFF: non-executable (instruction executing) ON: executable
R914D	COM3 port SEND / RECV command execution completion flag	Indicates the status with respect to the F145 (SEND) or F146 (RECV) instruction of the COM3 port. OFF: normal completion ON: abnormal completion (a communication error occurs) The error code is stored to DT90127.
R914E	Unused	
R914F	Unused	

(Note 1): R9040 - R904F will change even during a scanning cycle. In addition, it is compatible with the older model FP-X control unit, the special internal relay in parentheses also can be allocated the same function.

WR915 (specified in word)

Relay number	Name	Contents
R9150	COM4 port communication error flag	When perform data communication, if a transmission error occurs, it is ON. When executing F159 (MTRN) instruction, if transmitting is required, it is OFF.
R9151 -R9153	Unused	
R9154	COM4 port SEND / RECV command executable flag	Indicates the instruction with respect to the F145 (SEND) or F146 (RECV) instruction of the COM4 port is executable / non-executable. OFF: non-executable (instruction executing) ON: executable
R9155	COM4 port SEND / RECV command execution completion flag	Indicates the status with respect to the F145 (SEND) or F146 (RECV) instruction of the COM4 port. OFF: normal completion ON: abnormal completion (a communication error occurs) The error code is stored to DT90128.
R9156 -R915F	Unused	

11.5 Special Data Register List

Register Number	Name	Contents	Read	Write
DT90000	Self-diagnostic error code	When a self-diagnostic error occurs, the error code is stored.	○	×
DT90001	Unused		×	×
DT90002	Function card I/O error occurring location	<p>When an error occurs in the function card, the corresponding bit is ON.</p> <p>15 11 7 3 2 1 0 (Bit No.)</p> <p>ON (1): Abnormal OFF (0): Normal</p>	○	×
DT90003 -DT90005	Unused		×	×
DT90006	Function card error occurring location	<p>When an error occurs in the function card, the corresponding bit is ON.</p> <p>15 11 7 3 2 1 0 (Bit No.)</p> <p>ON (1): Abnormal OFF (0): Normal</p>	○	×
DT90007	System register error number	When there is mismatch in the setting content of the system register, save the object system register number.	○	×
DT90008	Communication error flag COM4 port	<p>Save error contents when using the COM4 port.</p> <p>bit no. 15 8 7 0</p> <p>H00 Fixed COM4 Overflow error COM4 Parity error COM4 Framing error COM4 Run overflow error</p>	○	×
DT90009	Communication error flag COM2 port / COM3 port	<p>Save error contents when using the COM2 / COM3 port.</p> <p>bit no. 15 8 7 0</p> <p>COM3 Overflow error COM3 Parity error COM3 Framing error COM3 Run overflow error COM2 Overflow error COM2 Parity error COM2 Framing error COM2 Run overflow error</p>	○	×
DT90010	FP-X expansion I/O check inconsistent unit location	<p>When the FP-X expansion I/O unit installation state turns to power ON, the corresponding bit to the unit number is ON (1). Monitor with BIN display.</p> <p>15 11 7 6 5 4 3 2 1 0 (Bit No.)</p> <p>ON (1): Abnormal OFF (0): Normal</p>	○	×

Register Number	Name	Contents	Read	Write																					
DT90011	Expansion card check inconsistent unit location	When the FP-X expansion card installation state turns to power ON, the corresponding bit to the expansion card number is ON (1). Monitor with BIN display. <div style="text-align: center;"> <table style="border-collapse: collapse; margin: auto;"> <tr> <td style="padding: 0 10px;">15</td> <td style="padding: 0 10px;">11</td> <td style="padding: 0 10px;">7</td> <td style="padding: 0 10px;">3</td> <td style="padding: 0 10px;">2</td> <td style="padding: 0 10px;">1</td> <td style="padding: 0 10px;">0 (Bit No.)</td> </tr> <tr> <td colspan="6" style="border-top: 1px solid black; border-bottom: 1px solid black;"></td> <td style="border-top: 1px solid black; border-bottom: 1px solid black;"></td> </tr> <tr> <td colspan="6"></td> <td style="text-align: center;">2 1 (Expansion No.)</td> </tr> </table> </div> ON (1): Abnormal OFF (0): Normal	15	11	7	3	2	1	0 (Bit No.)														2 1 (Expansion No.)	○	×
15	11	7	3	2	1	0 (Bit No.)																			
						2 1 (Expansion No.)																			
DT90012 -DT90013	Unused		×	×																					
DT90014	Operation auxiliary register of the data shift instruction	After executing the data shift instruction F105 (BSR) or F106 (BSL), the 1 digit data removed out is saved to the bit 0 - 3. Execute F0 (MV) instruction, values can be read and write.	○	○																					
DT90015	Operation auxiliary register of the division instruction	When executing 16-bit division instruction F32 (%), F52 (B%), the 16 bit of the remainder is saved to DT90015.	○	○																					
DT90016		When executing 32-bit division instruction F33 (D%), F53 (DB%), the 32 bit of the remainder is saved to DT90015-DT90016. Execute F1 (DMV) instruction, values can be read and write.	○	○																					
DT90017	Operation error address (hold)	After running, the address occurs an operation error first is stored. Please use decimalism display to perform monitoring.	○	×																					
DT90018	Operation error address (latest)	The address where an error occurred is stored. Update when each time an error occurs. Scanning start bit is 0. Please use decimalism display to perform monitoring.	○	×																					
DT90019	2.5 ms RING counter ^(Note 2)	The stored value is increased by 1 every 2.5 ms. (H0-HFFFF) The difference between 2 points (absolute value) × 2.5 ms = elapsed time between 2 points	○	×																					
DT90020	10 μs RING counter ^(Note 2, 3)	Saved value +1 every 10.67 μs. (H0-HFFFF) The difference between 2 points (absolute value) × 10.67 μs = (elapsed time between 2 points) note) the correct value is 10.67 μs.	○	×																					
DT90021	Unused		×	×																					
DT90022	Scanning time (current value) ^(Note 1)	The current value of the scanning time is saved. [Saved value (decimal)] × 0.1 ms (Example) For K50, it indicates within 5 ms.	○	×																					
DT90023	Scanning time (min) ^(Note 1)	The minimum value of the scanning time is saved. [Saved value (decimal)] × 0.1 ms (Example) For K50, it indicates within 5 ms.	○	×																					
DT90024	Scanning time (max) ^(Note 1)	The maximum value of the scanning time is saved. [Saved value (decimal)] × 0.1 ms (Example) For K125, it indicates within 12.5 ms.	○	×																					

(Note 1): The scanning time and operation cycle time only display in RUN mode. The scanning time of the operation is not displayed in PROG. mode. When the maximum and minimum value are shifted between RUN mode and PROG. mode, they are temporarily cleared.

(Note 2): During one scan, it is updated once at the beginning.

(Note 3): DT90020 is also updated when executing F0 (MV), therefore, it can be used to measure the time interval.

Register Number	Name	Contents	Read	Write
DT90025	Interrupt enable (mask) state (INT0 - 13)	<p>The content set by the ICTL instruction is saved. Monitor with BIN display.</p> <p>INT0 - INT7: interrupt input X0 - X7 INT8 - INT10: interrupt input X100 - X102 INT11 - INT13: interrupt input X200 - X202 INT0 - INT9: high-speed counter match interrupt CH0 - CH9 INT11 - INT12: high-speed counter match interrupt CHA, CHB</p>	○	×
DT90026	Unused		×	×
DT90027	Timer interrupt interval (INT24)	<p>The content set by the ICTL instruction is saved. K0: do not use the timer interrupt. K1 - K3000: 0.5 ms - 1.5 s or 10 ms - 30 s</p>	○	×
DT90028	Sampling and tracking interval	<p>K0: changed to sampling performed according to the SMPL instruction. K1 - K3000 (× 10ms): 10 ms - 30 s</p>	○	×
DT90029	Unused		×	×
DT90030	Save characters by F149MSG instruction	Save contents set through the information display instruction (F149) (character).	○	×
DT90031				
DT90032				
DT90033				
DT90034				
DT90035				
DT90036	Unused		×	×
DT90037	Job 1 for search instruction	When executing F96 (SRC) instruction, the number that is consistent with the search data is saved.	○	×
DT90038	Job 2 for search instruction	When executing F96 (SRC) instruction, a consistent relative position is saved.	○	×
DT90039	Unused		×	×
DT90040	Potentiometer input	<p>Save potentiometer value (K0 - K4000). Read to the data register by the user program, and it can be used in the analog timer.</p>	○	×
DT90041 -DT90043	Unused		×	×
DT90044	System job	Used in the system.	○	×
DT90045 -DT90051	Unused		×	×

Register Number	Name	Contents	Read	Write												
DT90053	Real-time clock monitoring (hour and minute)	<p>Save the hour and minute data of the real-time clock. You can only read, can not write.</p> <p style="text-align: center;">High byte Low byte</p> <p style="text-align: center;">Time data Minute data H00~H23 H00~H59</p>	○	×												
DT90054	Real-time clock (minute and second)	<p>Save the month, day, hour, minute, second, day and week data of the real-time clock. The built-in real time clock is applicable until 2099, also applicable for leap years. The real-time clock can be set (time adjustment) by using the programming tool or transfer instruction (F0) program to write in values.</p> <p style="text-align: center;">High byte Low byte</p> <table border="1" style="margin: 10px auto;"> <tr> <td>DT90054</td> <td>Minute data (H00-H59)</td> <td>Second data (H00-H59)</td> </tr> <tr> <td>DT90055</td> <td>Day data (H01-H31)</td> <td>Time data (H00-H23)</td> </tr> <tr> <td>DT90056</td> <td>Year data (H00-H99)</td> <td>Month data (H01-H12)</td> </tr> <tr> <td>DT90057</td> <td style="text-align: center;">—</td> <td>Week data (H00-H06)</td> </tr> </table> <p>The week data is not automatically set. Allocate any value within the range of H0 - 6.</p>	DT90054	Minute data (H00-H59)	Second data (H00-H59)	DT90055	Day data (H01-H31)	Time data (H00-H23)	DT90056	Year data (H00-H99)	Month data (H01-H12)	DT90057	—	Week data (H00-H06)	○	○
DT90054	Minute data (H00-H59)		Second data (H00-H59)													
DT90055	Day data (H01-H31)		Time data (H00-H23)													
DT90056	Year data (H00-H99)		Month data (H01-H12)													
DT90057	—		Week data (H00-H06)													
DT90055	Real-time clock (day and hour)															
DT90056	Real-time clock (year and month)															
DT90057	Real-time clock (week)															
DT90058	Real-time clock time setting and 30 seconds correction register	<p>Time adjustment for real-time clock.</p> <p>● Use the program to adjust the time</p> <p>If the highest bit of the DT90058 MSB is set to 1, it turns to the time written into the DT90054 - DT90057 by the instruction F0. After executing time adjustment, the DT90058 is cleared. (You can not execute instructions other than F0.)</p> <p><Example> When X0 is ON, adjust the time to 5 days 12 hours 0 minute 0 second.</p> <p style="text-align: right;">Set 0 minutes 0 seconds Set 5 minutes 12 hours Time adjustment</p> <p>● Correct the error within 30 seconds</p> <p>If the lowest bit of the DT90058 MSB is set to 1, it will increase or decrease and turn to 0 second. After performing the correction, the DT90058 is cleared.</p> <p><Example> When X0 is ON, correct it to 0 second.</p> <p style="text-align: right;">Corrected to 0 second</p> <p>Decrease when the execution time is 0-29 seconds, increase when it is 30-59 seconds. In the above example, if the time is 5 minutes and 29 seconds, it turns to 5 minutes 0 seconds. If the time is 5 minutes and 35 seconds, it turns to 6 minutes 0 seconds.</p>	○	○												

(Note 1): If use the programming tool to rewrite the value of DT90054 - DT90057, the time adjustment is performed when writing. Therefor, there is no need to execute DT90058 writing.

Register Number	Name	Contents	Read	Write
DT90059	Communication error code COM0 port / COM1 port	<p>When a communication error occurs, the error code is saved.</p> <p>bit no. 15 8 7 0</p> <p>0 0 0 0 0 0 0 0 0 0</p> <p>COM1 Overflow error</p> <p>COM1 Parity error</p> <p>COM1 Framing error</p> <p>COM1 Run overflow error</p> <p>COM0 Overflow error</p> <p>COM0 Parity error</p> <p>COM0 Framing error</p> <p>COM0 Run overflow error</p>	○	×
DT90060	Step ladder diagram program process (0 - 15)	<p>It indicates the starting status of the step ladder diagram program process. When the process starts, the bit corresponding to its process number is ON. Monitor with BIN display.</p> <p><Example></p> <p>DT90060 15 11 7 3 0 (Bit No.)</p> <p> 15 11 7 3 0 (Procedure No.)</p> <p> 1: Starting 0: Stopping</p> <p>The data can be written using a programming tool.</p>	○	○
DT90061	Step ladder diagram program process (16 - 31)			
DT90062	Step ladder diagram program process (32 - 47)			
DT90063	Step ladder diagram program process (48 - 63)			
DT90064	Step ladder diagram program process (64 - 79)			
DT90065	Step ladder diagram program process (80 - 95)			
DT90066	Step ladder diagram program process (96 - 111)			
DT90067	Step ladder diagram program process (112 - 127)			
DT90068	Step ladder diagram program process (128 - 143)			
DT90069	Step ladder diagram program process (144 - 159)			
DT90070	Step ladder diagram program process (160 - 175)			
DT90071	Step ladder diagram program process (176 - 191)			
DT90072	Step ladder diagram program process (192 - 207)			
DT90073	Step ladder diagram program process (208 - 223)			
DT90074	Step ladder diagram program process (224 - 239)			
DT90075	Step ladder diagram program process (240 - 255)			
DT90076	Step ladder diagram program process (256 - 271)			

Specification

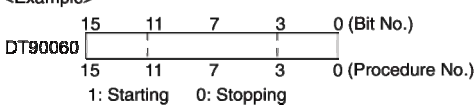
Register Number	Name	Contents	Read	Write
DT90077	Step ladder diagram program process (272 - 287)	<p>It indicates the starting status of the step ladder diagram program process. When the process starts, the bit corresponding to its process number is ON. Monitor with BIN display. <Example>  1: Starting 0: Stopping</p> <p>The data can be written using a programming tool.</p>	○	○
DT90078	Step ladder diagram program process (288 - 303)			
DT90079	Step ladder diagram program process (304 - 319)			
DT90080	Step ladder diagram program process (320 - 335)			
DT90081	Step ladder diagram program process (336 - 351)			
DT90082	Step ladder diagram program process (352 - 367)			
DT90083	Step ladder diagram program process (368 - 383)			
DT90084	Step ladder diagram program process (384 - 399)			
DT90085	Step ladder diagram program process (400 - 415)			
DT90086	Step ladder diagram program process (416 - 431)			
DT90087	Step ladder diagram program process (432 - 447)			
DT90088	Step ladder diagram program process (448 - 463)			
DT90089	Step ladder diagram program process (464 - 479)			
DT90090	Step ladder diagram program process (480 - 495)			
DT90091	Step ladder diagram program process (496 - 511)			
DT90092	Step ladder diagram program process (512 - 527)			
DT90093	Step ladder diagram program process (528 - 543)			
DT90094	Step ladder diagram program process (544 - 559)			
DT90095	Step ladder diagram program process (560 - 575)			
DT90096	Step ladder diagram program process (576 - 591)			
DT90097	Step ladder diagram program process (592 - 607)			
DT90098	Step ladder diagram program process (608 - 623)			
DT90099	Step ladder diagram program process (624 - 639)			
DT90100	Step ladder diagram program process (640 - 655)			
DT90101	Step ladder diagram program process (656 - 671)			

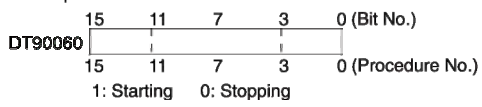
Register Number	Name	Contents	Read	Write
DT90102	Step ladder diagram program process (672 - 687)	<p>It indicates the starting status of the step ladder diagram program process. When the process starts, the bit corresponding to its process number is ON.</p> <p>Monitor with BIN display.</p> <p><Example></p>  <p>DT90060</p> <p>15 11 7 3 0 (Bit No.)</p> <p>15 11 7 3 0 (Procedure No.)</p> <p>1: Starting 0: Stopping</p>	○	○
DT90103	Step ladder diagram program process (688 - 703)			
DT90104	Step ladder diagram program process (704 - 719)			
DT90105	Step ladder diagram program process (720 - 735)			
DT90106	Step ladder diagram program process (736 - 751)			
DT90107	Step ladder diagram program process (752 - 767)			
DT90108	Step ladder diagram program process (768 - 783)			
DT90109	Step ladder diagram program process (784 - 799)			
DT90110	Step ladder diagram program process (800 - 815)			
DT90111	Step ladder diagram program process (816 - 831)			
DT90112	Step ladder diagram program process (832 - 847)			
DT90113	Step ladder diagram program process (848 - 863)			
DT90114	Step ladder diagram program process (864 - 879)			
DT90115	Step ladder diagram program process (880 - 895)			
DT90116	Step ladder diagram program process (896 - 911)			
DT90117	Step ladder diagram program process (912 - 927)			
DT90118	Step ladder diagram program process (928 - 943)			
DT90119	Step ladder diagram program process (944 - 959)			
DT90120	Step ladder diagram program process (960 - 975)			
DT90121	Step ladder diagram program process (976 - 991)			
DT90122	Step ladder diagram program process (992 - 999) (high byte not used)			

The data can be written using a programming tool.

Specification

Register Number	Name	Contents	Read	Write
DT90123	COM0 SEND / RECV end code	If an error occurs when executing SEND / RECV instruction, the error code is saved.	○	×
DT90124	COM1 SEND / RECV end code		○	×
DT90125	COM2 SEND / RECV end code		○	×
DT90126	Forcible input and output in process unit number	Used in the system.	○	×
DT90127	COM3 SEND / RECV end code	If an error occurs when executing SEND / RECV instruction, the error code is saved.	○	×
DT90128	COM4 SEND / RECV end code		○	×
DT90129 - DT90139	Unused		×	×

Register Number	Name	Contents	Read	Write
DT90140	MEWNET-W0 PC (PLC) link 0 status	PC (PLC) link 0 reception times	○	×
DT90141		PC (PLC) link 0 reception interval (current value) (× 2.5 ms)		
DT90142		PC (PLC) link 0 reception interval (minimum value) (× 2.5 ms)		
DT90143		PC (PLC) link 0 reception interval (maximum value) (× 2.5 ms)		
DT90144		PC (PLC) link 0 transmission times		
DT90145		PC (PLC) link 0 transmission interval (current value) (× 2.5 ms)		
DT90146		PC (PLC) link 0 transmission interval (minimum value) (× 2.5 ms)		
DT90147		PC (PLC) link 0 transmission interval (maximum value) (× 2.5 ms)		
DT90148	MEWNET-W0 PC (PLC) link 1 status	PC (PLC) link 1 reception times	○	×
DT90149		PC (PLC) link 1 reception interval (current value) (× 2.5 ms)		
DT90150		PC (PLC) link 1 reception interval (minimum value) (× 2.5 ms)		
DT90151		PC (PLC) link 1 reception interval (maximum value) (× 2.5 ms)		
DT90152		PC (PLC) link 1 transmission times		
DT90153		PC (PLC) link 1 transmission interval (current value) (× 2.5 ms)		
DT90154		PC (PLC) link 1 transmission interval (minimum value) (× 2.5 ms)		
DT90155		PC (PLC) link 1 transmission interval (maximum value) (× 2.5 ms)		
DT90156	MEWNET-W0 PC (PLC) link 0 status	PC (PLC) link 0 reception interval measurement job	○	×
DT90157		PC (PLC) link 0 send interval measurement job		
DT90158	MEWNET-W0 PC (PLC) link 1 status	PC (PLC) link 1 reception interval measurement job	○	×
DT90159		PC (PLC) link 1 send interval measurement job		
DT90160	MEWNET-W0 PC (PLC) link 0 unit No.	The PC (PLC) link 0 unit No. is saved.	○	×
DT90161	MEWNET-W0 PC (PLC) link 0 error flag	The error content of PC (PLC) link 0 is saved.	○	×
DT90162- DT90169	Unused		×	×
DT90170	MEWNET-W0 PC (PLC) link 0 status	PC (PLC) link address repeat target	○	×
DT90171		Token missing number		
DT90172		Double tokens number		
DT90173		No signal state number		
DT90174		Undefined instruction reception number		
DT90175		Reception sum check error number		
DT90176		Received data format error number		
DT90177		Transmission error occurrence number		
DT90178		Handler error occurrence number		
DT90179		Master station overlapping occurrence number		
DT90180 -DT90218	Unused		×	×

Register Number	Name	Contents	Read	Write		
DT90219	Station number switch of DT90220 - DT90251	0: Station number 1-8, 1: Station number 9-16	○	×		
DT90220	PC (PLC) link station 1 or 9	System registers 40 and 41	<p>The setting contents of the system register related to each station number PC (PLC) link function are saved as following.</p> <p>< Example > When the DT90219 is 0</p> <p>DT90220- DT90223 (Station number 1)</p>	○	×	
DT90221		System registers 42 and 43				
DT90222		System registers 44 and 45				
DT90223		System registers 46 and 47				
DT90224	PC (PLC) link station 2 or 10	System registers 40 and 41				
DT90225		System registers 42 and 43				
DT90226		System registers 44 and 45				
DT90227		System registers 46 and 47				
DT90228		System registers 40 and 41				
DT90229	PC (PLC) link station 3 or 11	System registers 42 and 43				If the master station system register 46 is standard setting, left 46, 47 will copy the value of the master station.
DT90230		System registers 44 and 45				If the master station system register 46 is set reversely, it indicates the left master station part 40-45 and 47 are set to 50-55 and 57, 46 remain unchanged.
DT90231		System registers 46 and 47				In addition, it indicates the other station part 40-45 are set to values after correcting the received values, while 46 and 47 are set to 46 and 57 of the master station.
DT90232	PC (PLC) link station 4 or 12	System registers 40 and 41				
DT90233		System registers 42 and 43				
DT90234		System registers 44 and 45				
DT90235		System registers 46 and 47				

Register Number	Name		Contents	Read	Write			
DT90236	PC (PLC) link station 5 or 13	System registers 40 and 41	<p>The setting contents of the system register related to each station number PC (PLC) link function are saved as following.</p> <p><Example></p>	○	×			
DT90237		System registers 42 and 43						
DT90238		System registers 44 and 45						
DT90239		System registers 46 and 47						
DT90240	PC (PLC) link station 6 or 14	System registers 40 and 41						
DT90241		System registers 42 and 43						
DT90242		System registers 44 and 45						
DT90243		System registers 46 and 47						
DT90244	PC (PLC) link station 7 or 15	System registers 40 and 41				<p>If the master station system register 46 is standard setting, left 46, 47 will copy the value of the master station.</p> <p>If the master station system register 46 is set reversely, it indicates the left master station part 40-45 and 47 are set to 50-55 and 57, 46 remain unchanged.</p> <p>In addition, it indicates the other station part 40-45 are set to values after correcting the received values, while 46 and 47 are set to 46 and 57 of the master station.</p>	○	×
DT90245		System registers 42 and 43						
DT90246		System registers 44 and 45						
DT90247		System registers 46 and 47						
DT90248	PC (PLC) link station 8 or 16	System registers 40 and 41						
DT90249		System registers 42 and 43						
DT90250		System registers 44 and 45						
DT90251		System registers 46 and 47						
DT90252 -DT90299	Unused			×	×			

Universal for FP-XH CxxR / CxxT

Register Number	Name		Contents	Read	Write
DT90300	Elapsed value area	Low byte word	The counting area of the high-speed counter controller input CH0 (X0) or (X0, X1). When executing the F166 (HC1S) and F167 (HC1R) instruction, the target value is saved.	<input type="radio"/>	<input type="radio"/>
DT90301		High byte word		<input type="radio"/>	<input type="radio"/>
DT90302	Target value area	Low byte word		<input type="radio"/>	<input type="radio"/>
DT90303		High byte word		<input type="radio"/>	<input type="radio"/>
DT90304	Elapsed value area	Low byte word	The counting area of the high-speed counter controller input (X1). When executing the F166 (HC1S) and F167 (HC1R) instruction, the target value is saved.	<input type="radio"/>	<input type="radio"/>
DT90305		High byte word		<input type="radio"/>	<input type="radio"/>
DT90306	Target value area	Low byte word		<input type="radio"/>	<input type="radio"/>
DT90307		High byte word		<input type="radio"/>	<input type="radio"/>
DT90308	Elapsed value area	Low byte word	The counting area of the high-speed counter controller input (X2) or (X2, X3). When executing the F166 (HC1S) and F167 (HC1R) instruction, the target value is saved.	<input type="radio"/>	<input type="radio"/>
DT90309		High byte word		<input type="radio"/>	<input type="radio"/>
DT90310	Target value area	Low byte word		<input type="radio"/>	<input type="radio"/>
DT90311		High byte word		<input type="radio"/>	<input type="radio"/>
DT90312	Elapsed value area	Low byte word	The counting area of the high-speed counter controller input (X3). When executing the F166 (HC1S) and F167 (HC1R) instruction, the target value is saved.	<input type="radio"/>	<input type="radio"/>
DT90313		High byte word		<input type="radio"/>	<input type="radio"/>
DT90314	Target value area	Low byte word		<input type="radio"/>	<input type="radio"/>
DT90315		High byte word		<input type="radio"/>	<input type="radio"/>
DT90316	Elapsed value area	Low byte word	The counting area of the high-speed counter controller input (X4) or (X4, X5). When executing the F166 (HC1S) and F167 (HC1R) instruction, the target value is saved.	<input type="radio"/>	<input type="radio"/>
DT90317		High byte word		<input type="radio"/>	<input type="radio"/>
DT90318	Target value area	Low byte word		<input type="radio"/>	<input type="radio"/>
DT90319		High byte word		<input type="radio"/>	<input type="radio"/>
DT90320	Elapsed value area	Low byte word	The counting area of the high-speed counter controller input (X5). When executing the F166 (HC1S) and F167 (HC1R) instruction, the target value is saved.	<input type="radio"/>	<input type="radio"/>
DT90321		High byte word		<input type="radio"/>	<input type="radio"/>
DT90322	Target value area	Low byte word		<input type="radio"/>	<input type="radio"/>
DT90323		High byte word		<input type="radio"/>	<input type="radio"/>
DT90324	Elapsed value area	Low byte word	The counting area of the high-speed counter controller input (X6) or (X6, X7). When executing the F166 (HC1S) and F167 (HC1R) instruction, the target value is saved.	<input type="radio"/>	<input type="radio"/>
DT90325		High byte word		<input type="radio"/>	<input type="radio"/>
DT90326	Target value area	Low byte word		<input type="radio"/>	<input type="radio"/>
DT90327		High byte word		<input type="radio"/>	<input type="radio"/>
DT90328	Elapsed value area	Low byte word	The counting area of the high-speed counter controller input (X7). When executing the F166 (HC1S) and F167 (HC1R) instruction, the target value is saved.	<input type="radio"/>	<input type="radio"/>
DT90329		High byte word		<input type="radio"/>	<input type="radio"/>
DT90330	Target value area	Low byte word		<input type="radio"/>	<input type="radio"/>
DT90331		High byte word		<input type="radio"/>	<input type="radio"/>

(Note 1): Only F1 (DMV) instruction can perform the reading and writing of process value region.

(Note 2): When executing the high-speed counter target value consistent instruction F166 (HC1S) or F167 (HC1R) instruction, the target value area is set. It can not be written by the user program.

For FP-XH CxxR

Register Number	Name		Contents	Read	Write
DT90332	Elapsed value area	Low byte word	The counting area of the pulse input and output card high-speed counter input (X100) or (X100, X101).	<input type="radio"/>	<input type="radio"/>
DT90333		High byte word		<input type="radio"/>	<input type="radio"/>
DT90334	Target value area	Low byte word	When executing the F166 (HC1S) and F167 (HC1R) instruction, the target value is saved.	<input type="radio"/>	<input type="radio"/>
DT90335		High byte word		<input type="radio"/>	<input type="radio"/>
DT90336	Elapsed value area	Low byte word	The counting area of the pulse input and output card high-speed counter input (X101).	<input type="radio"/>	<input type="radio"/>
DT90337		High byte word		<input type="radio"/>	<input type="radio"/>
DT90338	Target value area	Low byte word	When executing the F166 (HC1S) and F167 (HC1R) instruction, the target value is saved.	<input type="radio"/>	<input type="radio"/>
DT90339		High byte word		<input type="radio"/>	<input type="radio"/>
DT90340	Elapsed value area	Low byte word	The counting area of the pulse input and output card high-speed counter input (X200) or (X200, X201).	<input type="radio"/>	<input type="radio"/>
DT90341		High byte word		<input type="radio"/>	<input type="radio"/>
DT90342	Target value area	Low byte word	When executing the F166 (HC1S) and F167 (HC1R) instruction, the target value is saved.	<input type="radio"/>	<input type="radio"/>
DT90343		High byte word		<input type="radio"/>	<input type="radio"/>
DT90344	Elapsed value area	Low byte word	The counting area of the pulse input and output card high-speed counter input (X201).	<input type="radio"/>	<input type="radio"/>
DT90345		High byte word		<input type="radio"/>	<input type="radio"/>
DT90346	Target value area	Low byte word	When executing the F166 (HC1S) and F167 (HC1R) instruction, the target value is saved.	<input type="radio"/>	<input type="radio"/>
DT90347		High byte word		<input type="radio"/>	<input type="radio"/>

(Note 1): Only F1 (DMV) instruction can perform the reading and writing of process value region.

(Note 2): When executing the high-speed counter target value consistent instruction F166 (HC1S) or F167 (HC1R) instruction, the target value area is set. It can not be written by the user program.

(Note 3): When the pulse input and output card is used only through the relay type control unit, the DT90332 - DT90347 are effective.

Specification

FP-XH CxxR (FP-X compatible instruction mode)

Register Number	Name		Contents	Read	Write	
DT90348	Elapsed value area	Low byte word	PLS-CH0	The counting area of the pulse input and output card pulse output (Y100, Y101).	○	○
DT90349		High byte word			○	○
DT90350	Target value area	Low byte word		When executing the pulse output instruction (F17x), the target value is set.	○	○
DT90351		High byte word			○	○
DT90352	Elapsed value area	Low byte word	PLS-CH1	The counting area of the pulse input and output card pulse output (Y200, Y201).	○	○
DT90353		High byte word			○	○
DT90354	Target value area	Low byte word		When executing the pulse output instruction (F17x), the target value is set.	○	○
DT90355		High byte word			○	○
DT90356 -DT90371	Unused			×	×	

(Note 1): Only F1 (DMV) instruction can perform the reading and writing of process value region.

(Note 2): Only F1 (DMV) instruction can perform the reading and writing of target value region.

(Note 3): When executing the pulse output instruction F171 (SPDH), F172 (PLSH), F174 (SP0H) and F175 (SPSH) instruction, the target value area is set. It can not be written by the user program.

For FP-XH CxxT (FP-X compatible instruction mode)

Register Number	Name		Contents	Read	Write	
DT90348	Elapsed value area	Low byte word	PLS-CH0	The counting area of the pulse output CH0 (Y0, Y1).	○	○
DT90349		High byte word			○	○
DT90350	Target value area	Low byte word		When executing the pulse output instruction (F17x), the target value is set.	○	○
DT90351		High byte word			○	○
DT90352	Elapsed value area	Low byte word	PLS-CH1	The counting area of the pulse output CH1 (Y2, Y3).	○	○
DT90353		High byte word			○	○
DT90354	Target value area	Low byte word		When executing the pulse output instruction (F17x), the target value is set.	○	○
DT90355		High byte word			○	○
DT90356	Elapsed value area	Low byte word	PLS-CH2	The counting area of the pulse output CH2 (Y4, Y5).	○	○
DT90357		High byte word			○	○
DT90358	Target value area	Low byte word		When executing the pulse output instruction (F17x), the target value is set.	○	○
DT90359		High byte word			○	○
DT90360	Elapsed value area	Low byte word	PLS-CH3	The counting area of the pulse output CH3 (Y6, Y7).	○	○
DT90361		High byte word			○	○
DT90362	Target value area	Low byte word		When executing the pulse output instruction (F17x), the target value is set.	○	○
DT90363		High byte word			○	○
DT90364	Elapsed value area	Low byte word	PLS-CH4	The counting area of the pulse output CH4 (Y8, Y9).	○	○
DT90365		High byte word			○	○
DT90366	Target value area	Low byte word		When executing the pulse output instruction (F17x), the target value is set.	○	○
DT90367		High byte word			○	○
DT90368	Elapsed value area	Low byte word	PLS-CH5	The counting area of the pulse output CH5 (YA, YB).	○	○
DT90369		High byte word			○	○
DT90370	Target value area	Low byte word		When executing the pulse output instruction (F17x), the target value is set.	○	○
DT90371		High byte word			○	○

(Note 1): Only F1 (DMV) instruction can perform the reading and writing of process value region.

(Note 2): Only F1 (DMV) instruction can perform the reading and writing of target value region.

(Note 3): When executing the pulse output instruction F171 (SPDH), F172 (PLSH), F174 (SP0H) and F175 (SPSH) instruction, the target value area is set. It can not be written by the user program.

11.6 Error Code List

11.6.1 Syntax Check Error List

Error Codes 1-8

Code	Name	Run	Error content and handling method
E1	Syntax error	Stop	<ul style="list-style-type: none"> ● A sequencer with syntax errors has been written in. ● Switch to PROG. mode and correct the error.
E2	Reuse (definition) error (note 1)	Stop	<ul style="list-style-type: none"> ● The same relay was used repeatedly in the output instruction and hold instruction. It also happens when using the same timer / counter number. ● Switch to PROG. mode and revise the program to ensure that the relay is only outputted once in the program. Or, select to allow dual output by the system register No. 20. However, even in the choice of running dual output, a timer / counter instruction reuse definition error is still detected.
E3	Match not established error	Stop	<ul style="list-style-type: none"> ● Executing by the instruction for matching (JP and LBL etc.) is not possible due to one is missing or there is a wrong positioning relation. ● Switch to PROG. mode and enter the 2 instructions for matching into the correct position.
E4	Parameter mismatch error	Stop	<ul style="list-style-type: none"> ● An instruction word inconsistent with the system register settings was written in. The range setting of the timer / counter is inconsistent with the number assignment in the program. ● Switch to PROG. mode to confirm the contents of the system register, and reconcile the setting and instruction word.
E5	Instruction position error (note 1)	Stop	<ul style="list-style-type: none"> ● The instruction to determine executable area (main program area, deputy program area) is written into a position outside of the area (the subroutine SUB - RET etc. were recorded before the ED instruction). ● Switch to PROG. mode, and enter the instruction into the specified area.
E6	The compiler memory is full	Stop	<ul style="list-style-type: none"> ● Unable to compile all programs. ● Switch to PROG. mode to reduce the total number of steps of the program.
E7	Application instructions combination error	Stop	<ul style="list-style-type: none"> ● The executing for each scan type and differential execution type are mixed in multiple application instructions that perform continuous writing. ● Concentrate the executing for each scan type and differential execution type and add individual execution condition.
E8	Application instructions operand combinations error	Stop	<ul style="list-style-type: none"> ● The combination instruction is determined by multiple operands (unify types etc.), and the combination is wrong. ● Log operands with the correct combination.

(Note 1): The E2 and E5 error codes means that a syntax error can be detected even when performing the rewrite in which exists execution error in RUN mode. In this case, the control unit does not write anything, continue to run.

11.6.2 Self-diagnostic Error List

Code	Name	Run	Error content and handling method
E20	Watchdog timer timeout	Stop	<ul style="list-style-type: none"> ● The watchdog timer is started, but stops running. A hardware error or operation stagnation has occurred. ● Check if there is a infinite loop in the control instructions (JP, LOOP, etc.) used to change the program handling process. If the program itself is OK, it may be due to a hardware error.
E25	Inconsistent main memory models	Stop	<ul style="list-style-type: none"> ● The main memory models are inconsistent. Use a main memory created by the same model.
E26	User ROM error	Stop	<ul style="list-style-type: none"> ● When installing the main memory card, the main memory may be corrupted. ● Remove the main memory card to check for errors. If there is no error, the contents of the main memory may be corrupted. ● Use it after rewriting the main memory. If the error can not be cleared, please contact our company.
E27	Unit installation is restricted.	Stop	<ul style="list-style-type: none"> ● The unit installation number exceeds the limits. ● Turn off the power to confirm whether the combination unit is within the limit range.
E34	Abnormal I/O status	Stop	<ul style="list-style-type: none"> ● An abnormal unit is installed. ● Confirm the slot number by DT90036, replace the abnormal unit with a normal one.
E40	I/O error	Select	<ul style="list-style-type: none"> ● The function card may be abnormal. Confirm its location through the data register DT90002 and repair it. ● You can use the tool software to confirm it by the [I/O Error] button in the status display dialog box.
E41	Special unit collapse	Select	<ul style="list-style-type: none"> ● It may be due to abnormal high function unit. Confirm its location through the data register DT90006 and repair it. ● You can use the tool software to confirm it by the [Special Error] button in the status display dialog box.
E42	I/O check error	Select	<ul style="list-style-type: none"> ● The connection status of the input and output unit (expansion unit) is different from that when the power is turned on. ● Verify the input and output unit whose connection status changed through the special data registers DT90010 and DT90011. Or, verify the chimerism of the expansion unit. ● You can use the tool software to confirm it by the [Check Error] button in the status display dialog box.

Code	Name	Run	Error content and handling method
E44	A position control operation error occurred	Select	<ul style="list-style-type: none"> ● An error occurs when using the data sheet running function. ● Parameter settings may be incorrect, or there was a limit error. ● Check if the parameters are within the range that can be specified. ● The operation error address can be confirmed by one of the special register DT90017 and DT90018. You can use the tool software to confirm it by the [Position Control Error] button in the status display dialog box.
E45	Operation error occurred	Select	<ul style="list-style-type: none"> ● An operation error can not be performed occurred. ● The operation error address can be confirmed by one of the special register DT90017 and DT90018. You can use the tool software to confirm it by the [Operation Error] button in the status display dialog box.
E48	Abnormal system register setting	Stop running	<ul style="list-style-type: none"> ● The settings of the system register are abnormal. Check the settings again. Example) If the data register and internal relay ranges set by the system register No. 0 and No. 1 are not matched with the setting of the system register No. 7 and No. 8 hold / non-hold area and the setting of the system register No. 416-No. 423 universal communication buffer area, an error will occur. ● Verify the number of the system register through the special register DT90007.
E49	Abnormal expansion power sequence	Stop running	<ul style="list-style-type: none"> ● The power of the expansion Unit is turned on later than the control unit. Make sure it is powered on before the control unit or at the same time.
E50	Abnormal battery (battery fall off or voltage reduced)	Stop running	<ul style="list-style-type: none"> ● The backup battery voltage is lower than the specified voltage, or the control unit is not connected to the battery. Verify the backup battery, pay attention to the replacement and connection work. ● You can set whether to notify the self-diagnostic error through the system register No. 4.
E100- E199	Self-diagnosis error set by F148	Stop	<ul style="list-style-type: none"> ● An error set by the application instruction F148 occurred. ● Handle it according to the detection conditions set.
E200- E299		Operation continues	

11.6.3 MEWTOCOL-COM Communication Error Code List

Code	Name	Error Contents
! 26	Unit number setting error	An instruction can not be used in the global area (station number FF) is received.
! 40	BCC error	A transmission error occurs in the received data.
! 41	Wrong format	An instruction inconsistent with the format is received.
! 42	NOT support error	An unsupported instruction is received.
! 43	Multiple frames procedure error	In the multi-frame processing, another instruction is received.
! 60	Parameter error	The specified parameter content does not exist or can not be used.
! 61	Data error	There is an error in the contact, data area, data number assignment, size assignment, range and format assignment.
! 62	Login overrun error	Exceeds login times or operate without logging in.
! 63	PC mode error	An instruction can not be processed was executed in RUN mode.
! 64	Bad external recording error	Bad hardware. The built-in ROM (F-ROM) / main memory may be abnormal. The capacity of the specified content was exceeded during ROM transmission. A read / write error occurred.
! 65	Protection error	A write operation of the program or system register was performed under the protection status or with the main memory card installed.
! 66	Address error	There is an error in the code format of the address data. In addition, there is an error in the range assignment when it is exceeded or insufficient.
! 67	No program error / no data error	It is not possible to read due to the program area has no program or abnormal memory contents. Or you want to read an unregistered data.
! 68	Can not rewrite in RUN error	Edit instructions can not be rewritten in RUN (ED, SUB, RET, INT, IRET, SSTP, STPE). Nothing has written into the control unit.
! 70	SIM overrun error	Exceeds the program area during program write processing.
! 71	Exclusive control error	Execution of the instruction can not be processed simultaneously with the instructions in process.

11.7 Dimensions

11.7.1 Dimensions

■ FP-XH C14 control unit

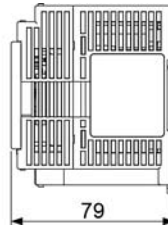
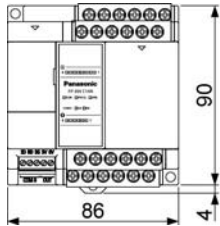

■ FP-XH C30 control unit

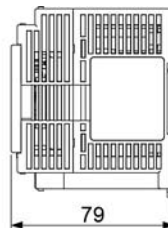
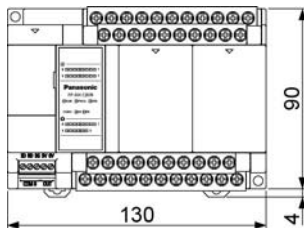

■ FP-XH C40 control unit

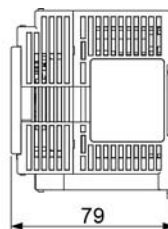
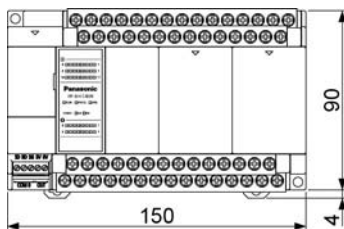

■ FP-XH C60 control unit

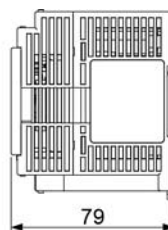
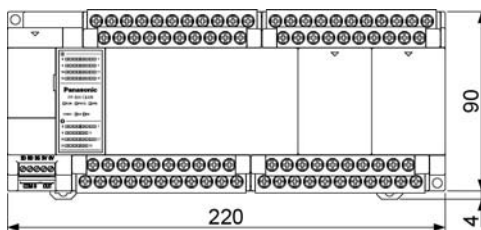

Unit: mm

11.7.2 Installation Dimensions

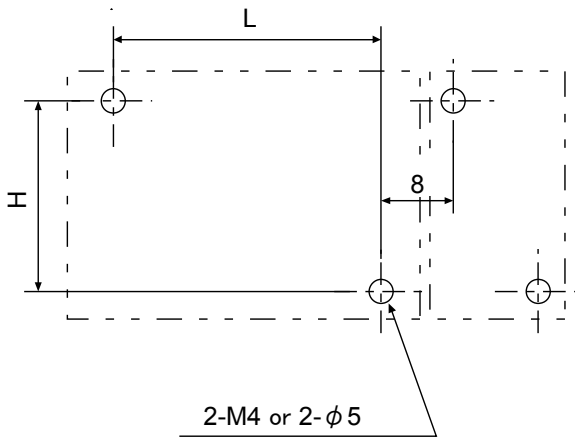

Model	L	H
C14	78	82
C30	122	82
C40	142	82
C60	212	82

Unit: mm

Revision History

The manual No. is recorded beneath the cover.

Issue Date	Manual No.	Revision Contents
June 2014	WUMC-FPXHBAS-01	First Edition
December 2014	WUMC-FPXHBAS-02	Second Edition
		<ul style="list-style-type: none">• Additional Features 32 Character Password Feature <ul style="list-style-type: none">• Corrected Errors

About Warranty

The products and specifications listed in this document are subject to change without prior notice as occasioned by the improvements that we introduce into our products. Therefore, when you consider the use of the product and place orders for the product, you may contact our customer service representatives and check that the details listed in this document are commensurate with the most up-to-date information.

We spare no efforts to give the utmost care and attention to the quality of this product. However, to ensure optimal performance, we recommend that:

- 1) When our product is used beyond the range of the specifications, environment or conditions listed herein, or it is used in any environment or conditions not listed herein, or when you are considering the use of product in any condition or environment that is not specified herein, or when you are considering the use of our product for particular purposes for which high reliability is required such as safety environment and control systems used for the railroad, aviation or medical care industries, you should contact our customer service representatives and obtain proper specification sheets.
- 2) Consult with us for the specifications of your own products, end users, environment and conditions of use, installation locations, etc. to prevent accidents caused by the items not listed herein.
- 3) Take safety measures (such as double interlock, etc.) to the external circuit of the product to ensure the safety of the whole system in case of abnormalities caused by product failure or external factors. Also, please use this product within its limits and capacity mentioned in this document.
- 4) For the product you have purchased from us or with the product delivered to your premises, promptly perform an acceptance inspection; for handling of our product both before and during the acceptance inspection, give full attention to the control and preservation of our product.

Warranty period

The warranty period of this product is 3 years from either the date of purchase or the date on which the product is delivered to the location specified by the Buyer. However, the warranty period (the so-called "3 years") shall be valid only until 42 months from the date of manufacture which includes a maximum of 6-month distribution period.

Warranty scope

In the event of any failure or obvious defect in the product due to the reasons solely attributable to Panasonic Electric Works, Panasonic Electric Works shall remedy such malfunctioning or defective product at its own cost in one of the following ways: i) repair such product; ii) replace such product; iii) supply of replacement parts. However, the warranty shall not cover the failures or defects arising from any of the following reasons.

1. Specifications, standards and handling procedures specified by the Buyer;
2. Modifications to the structure, performance or specifications performed by a party other than the Seller after the date of purchase or the date on which the product is delivered;
3. Phenomena that could not be foreseen with the technology that has been put into practical use after purchase or at the time of signing;
4. Cases that the range of conditions, circumstances or environment described in the manual or specification sheet are exceeded;
5. Damages that could be avoided if Buyer's product provides the function and structure generally accepted in the industry when this product is incorporated into Buyer's product;
6. Natural disasters or force majeure;
7. Consumable goods such as battery and relay or optional accessories such as cables.

In addition, the warranty described herein shall only cover the single unit purchased or delivered by Panasonic Electric Works. Damages arising from failures or defects of this product are excluded from this warranty.

●Please contact us

Panasonic Industrial Devices Sales (China) Co., Ltd.

2F, Buildings 7 & 8, No. 88, Maji Road, China (Shanghai) Pilot Free Trade Zone
Tel: 021-3855-2000

Customer Service Center of Panasonic Semiconductor (Suzhou) Co., Ltd.

Customer Service Hotline : 400-920-9200

Panasonic Industrial Devices SUNX (Suzhou) Co., Ltd.

Address: No.97 Huoju Road, New District Suzhou, Jiangsu Province, China

Postal Code: 215009

Tel: 0512-6843-2580

Fax: 0512-6843-2590

URL: panasonic.net/id/pidsx/global

© Panasonic Industrial Devices SUNX (Suzhou) Co., Ltd. 2015

Issued in October 2015 PRINTED IN CHINA WUMC-FPXHBAS-03