

# General Specifications

## Conductivity Detectors/Sensors

### GS 12D08G02-E

#### ■ GENERAL

YOKOGAWA has been supplying superior on-line analyzers for monitoring or controlling the conductivity of liquid or solutions.

Now, YOKOGAWA provides the four-wire Conductivity Converter (SC450G), the 4-Wire Converter (FLXA™402), the 2-Wire Liquid Analyzer (FLXA™202, FLXA™21).

YOKOGAWA also provides many kinds of detectors/sensors for accurately measuring liquid conductivity when using analyzers.

The combination of YOKOGAWA's analyzers and detectors/sensors meets the demanding ultrapurewater requirements of the growing semiconductor and pharmaceutical markets in addition to traditional water quality measurements for standard power plant and chemical applications.



Refer to GS 12D08N05-01E    Refer to GS 12A01F01-01EN    Refer to GS 12A01A02-01E    Refer to GS 12A01A03-01EN

FLEXA, FLXA, EXA SC are registered trademarks or trademarks of Yokogawa Electric Corporation.  
All other company and product names mentioned in this GS are registered trademarks or trademarks of their respective companies.

■ Models of Conductivity Detectors/Sensors

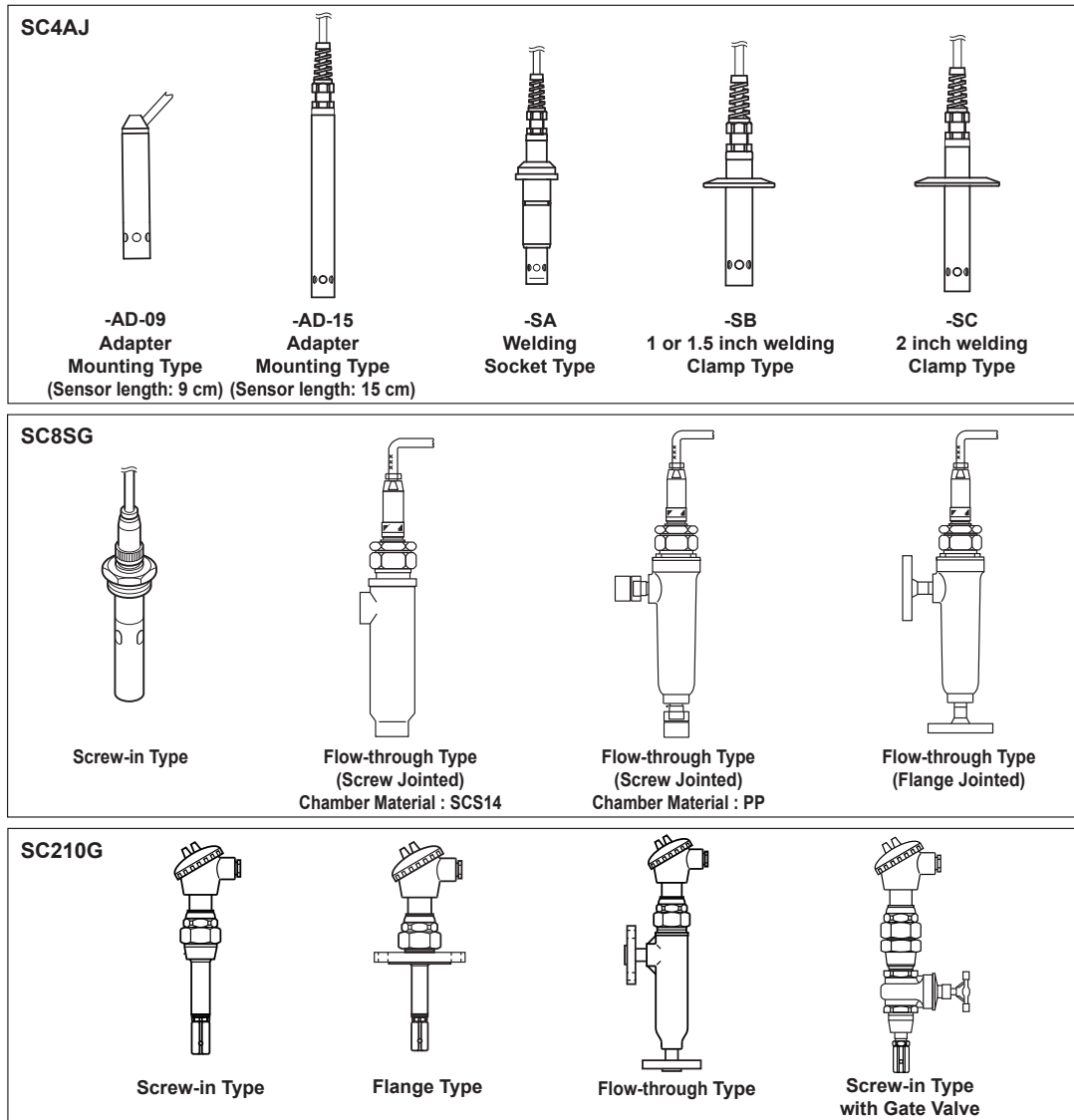

F01.ai

■ RANGE OF MEASURING UPPER RANGE LIMIT OF EACH SENSORS

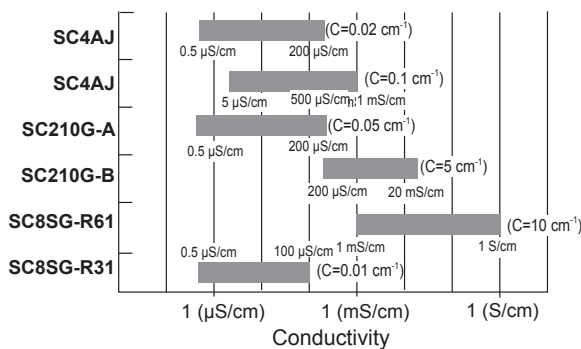

**NOTE:**  
 The bar graph at the left shows the range of the upper range limit of each sensor. For example, in the case of SC8SG-R61, the measuring range is from 0-1 mS/cm to 0-1 S/cm. In measurement in high conductivity range, polluted solution may affect measured values of any sensors. C represents cell constant.

F02.ai

## ■ GENERAL SPECIFICATIONS

### 1. SC4AJ:

- Cable with pin terminals (applicable to FLXA202, FLXA21)
- Cable with M3 ring terminals (applicable to FLXA402, SC450G)
- Cable with M4 ring terminals (applicable to FLXA202, FLXA21)
- Object of measurement: Conductivity of solutions
- Measuring principle: Two-electrode system
- Cell constant: 0.02 cm<sup>-1</sup>, 0.1 cm<sup>-1</sup>
- Measuring range:
  - For a cell constant: 0.02 cm<sup>-1</sup>:  
0-0.5 μS/cm to 0-200 μS/cm
  - For a cell constant: 0.1 cm<sup>-1</sup>:  
0-5 μS/cm to 1 mS/cm
- Temperature Range: For electrode, 0 to 110°C  
For holder, see Figure 1
- Sterilization for electrode:  
135°C (275°F), within 30 minutes in Steam Sterilization
- Pressure range : For electrode, 0 to 1 MPa  
For holder, see Figure 1

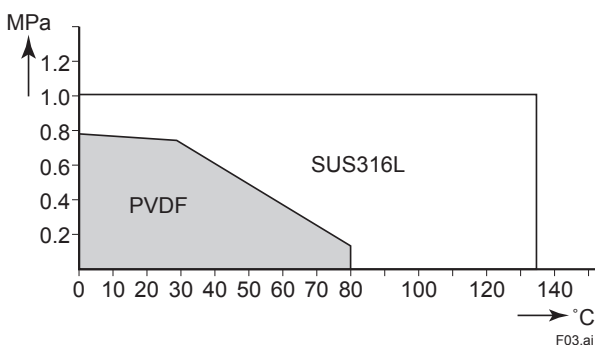

**Figure1: The range of tolerance of holders (option: /PS, /PF, /RS, /RF, /SA1, /SA2, /SB1, /SB2, /SC1) for temperature and pressure**

- Sample solution condition:
  - Although flow rate is not limited in measurement, air bubbles should not be mixed in the sample solutions to obtain correct measured values.
- Temperature sensor: Pt1000
- Materials: Stainless steel (316L SS) (for all Fitting-type) or Titanium (only for adapter mounting type-AD), polyetheretherketone (PEEK), Fluoro rubber (FKM) O-ring.
- Mounting adapter: Polyvinylidene difluoride (for /PF and /RF) or Stainless steel (316 SS), Stainless steel (316L SS)
- Weight:
  - Sensors:
    - Adapter mounting type (SC4AJ-S-AD-09-002-05): approx.450 g
    - Adapter mounting type (SC4AJ-S-AD-15-002-05): approx.520 g
    - Welding socket type (SC4AJ-S-SA-NN-002-05): approx.670 g
    - 1 or 1.5 inch welding clamp type (SC4AJ-S-SB-NN-002-05): approx.550 g
    - 2 inch welding clamp type (SC4AJ-S-SC-NN-002-05): approx.670 g

Note: There are weight differences among SC4AJ sensors. In order to know the more accurate weight of each type of sensors, please calculate it from following information. The cable weighs 75 g/m. The SC4AJ with 0.02 cm<sup>-1</sup> cell constant is 15 g heavier than the SC4AJ with 0.1 cm<sup>-1</sup> cell constant. 314L SS electrode is 40 g heavier than Titanium electrode.

- Adapters:
  - 3/4NPT stainless steel adapter (/PS): approx. 110 g
  - R3/4 stainless steel adapter (/RS): approx. 110 g
  - 3/4NPT PVDF adapter (/PF): approx. 35 g
  - R3/4 PVDF adapter (/RF): approx. 35 g
  - Straight welding socket (/SA1): approx. 300 g
  - Angle welding socket 15 (/SA2): approx. 320 g
  - Welding clamp 1 inch (/SB1): approx. 330 g
  - Welding clamp 1.5 inch (/SB2): approx. 305 g
  - Welding clamp 2 inch (/SC1): approx. 350 g
- note: Do not submerge the sensor itself in process water, as the seams between the mold and the metal of the sensor are not waterproof.

### 2. SC8SG:

- Cable with pin terminals (applicable to FLXA202, FLXA21)
- Cable with M3 ring terminals (applicable to FLXA402, SC450G)
- Cable with M4 ring terminals (applicable to FLXA202, FLXA21)
- Object of measurement: Conductivity of liquids
- Measuring Principle: 2-electrode system or 4-electrode system
- Cell Constants: 0.01 cm<sup>-1</sup> or 10 cm<sup>-1</sup> (for two-electrode system) 10 cm<sup>-1</sup> (for four-electrode system)
- Measuring Ranges: 0-0.5 μS/cm to 0-100 μS/cm for a cell constant of 0.01 cm<sup>-1</sup> 0-1 mS/cm to 0-1000 mS/cm for a cell constant of 10 cm<sup>-1</sup>
- Temperature Range: 0° to 100°C (130°C maximum only for 0.01 cm<sup>-1</sup> cell constant detectors, excluding those with polypropylene chambers)
- Pressure: 1000 kPa max. (500 kPa maximum for detectors with polypropylene chambers)
- Flow rate of Sample Solution: No particular limitation applies, although a value of less than 20 L/min. is recommended for flow-through detectors.
- Note: No limitation applies to flow rate (flow velocity) as far as measurement is concerned. Take care, however, when using flow-through detectors. Electrodes or the inner walls of a liquid chamber may wear put drastically at higher flow speeds if a measured solution contains slurry. Air bubbles should not be mixed in the sample solutions to obtain correct measured values.
- RTD for Temperature Compensation: Pt1000 (built into the sensor)
- Construction: Direct insertion (in-situ) type or flow-through types. Rainproof encapsulation (compatible with the JIS C0920 Japanese Industrial Standard)

**Installation :**

- Screw-in type: held by the process piping
- Flow-through type (polypropylene chamber)
  - : mounted on a pipe (nominal diameter of 50 mm  $\pm$ 2 in.)
- Flow-through type (SCS14 chamber)
  - : held by the process piping

Process Connection: Screw-in or flow-through

**Construction of Wetted Part:**

- Sensor-holding base:
  - Stainless steel (316 SS) and Fluoro rubber when using screw-in type holder or the chamber made of stainless steel.
  - PP and Fluoro rubber when using the chamber made of PP.
- 0.01 cm<sup>-1</sup> cell constant, two-electrode sensor:
  - Stainless steel (316 SS) and ethylene chloride trifluoride
- 10 cm<sup>-1</sup> cell constant, two-electrode sensor:
  - reinforced epoxy resin and graphite
- 10 cm<sup>-1</sup> cell constant, four-electrode sensor:
  - polyvinylidene difluoride, glass and platinum
- Stem (flow-through type):
  - SCS14 or polypropylene resin

**Weight:**

- Screw-in type
  - approximately 1.3 kg (excluding the cable)
- Flow-through type (SCS14 chamber)
  - approximately 3.1 kg (excluding the cable)
- Flow-through type (SCS14 chamber, flanged)
  - approximately 4.5 kg (excluding the cable)
- Flow-through type (polypropylene chamber)
  - approximately 2.7 kg (excluding the cable)
- Flow-through type (polypropylene chamber, flanged)
  - approximately 3.2 kg (excluding the cable)
- Cable
  - ; 0.3 kg for 5.5 m length
  - ; 0.5 kg for 10 m length
  - ; 0.9 kg for 20 m length.

**3. WU41: Dedicated cable for the SC8SG**

- Cable : Six multicore wire
- Diameter: 9.2 mm
- Material : Thermoplastic PVC

**4. SC210G:**

- Cable with pin terminals (applicable to FLXA202, FLXA21)
- Cable with M3 ring terminals (applicable to FLXA402, SC450G)
- Cable with M4 ring terminals (applicable to FLXA202, FLXA21)

**Object of measurement:**

Conductivity of solutions

Measuring principle: Two-electrode system

Cell constant : 0.05 cm<sup>-1</sup>, 5 cm<sup>-1</sup>

Measuring range : 0-0.5  $\mu$ S/cm to 0-200  $\mu$ S/cm  
(Cell constant: 0.05 cm<sup>-1</sup>)  
0-200  $\mu$ S/cm to 0-20 mS/cm  
(Cell constant: 5 cm<sup>-1</sup>)

Temperature Range: 0 to 105°C  
(chamber material: SCS14)  
0 to 100°C  
(chamber material: Polypropylene)

Pressure range : 0 to 1 MPa  
(chamber material: SCS14)  
0 to 500 kPa  
(chamber material: Polypropylene)

**Measuring solution condition:**

Although flow rate is not limited in measurement, less than 20 L/min is recommended for flow-through type. If slurry is included in sample solutions in flow-through type detectors, the electrode part and the inside of solution chamber may be worn significantly.

Air bubbles should not be mixed in the sample solutions to obtain correct measured values.

Temperature sensor: Thermistor (PB36NTC)

**Wet part Materials**

- SC210G-A: For sensor, Stainless steel (316 SS), Fluoro rubber (FKM) (O-ring) and Polytrifluorochloroethylene For body, Stainless steel (316 SS), polypropylene and Fluoro rubber (FKM) (O-ring)
- SC210G-B: For sensor, Platinum, glass and Fluoro rubber (FKM) (O-ring) For body, Stainless steel (316 SS), polypropylene and Fluoro rubber (FKM) (O-ring)

Flange (Flange type): Stainless steel (316 SS)

Flow-through type holder: SCS14 or polypropylene resin, Fluororubber(FKM) (O-ring)

Gate valve: SCS13A, Stainless steel (304 SS), Stainless steel (316 SS Hard chrome plating), Expanded graphite, PTFE

Construction: JIS C0920 watertight (equal to NEMA 4)

**■ Compliance with the simple apparatus requirements**

SC210G and SC4AJ meet the simple apparatus requirements defined in the following standards.

Note: TIS certified types cannot be connected.

Use the sensors under the conditions of use required by the standards.

**Applicable standards:**

- ANSI/ISA-60079-11 (2014)
- ANSI/ISA-60079-0 (2009)
- CAN/CSA-C22.2 NO. 60079-11:14
- CAN/CSA-C22.2 NO. 60079-0:11

방호장치 의무안전인증 고시  
GB 3836.4-2010

**Conditions of use:**

- (1) Use in combination with an internally isolated analyzer, or use with, an analyzer in combination with isolated barrier.  
The FLXA202/FLXA21 is internally isolated.
- (2) Upper limit of the process temperature.  
The upper limit of process temperature is indicated below when the sensor is used in combination with a YOKOGAWA analyzer.  
For FLXA202/FLXA21, model and suffix code below is available.
  - FLXA21-D-□-D-◇-C1-○-A-N-LA-N-NN
    - : can be any value.
    - ◇: must be EA, CD, CH, or EG.
    - : must be NN or C1.
    - Any option code is available.
  - FLXA202-D-□-D-◇-C1-○-A-N-LA-N-NN
    - : can be any value.
    - ◇: must be CD, CH, or CG.
    - : must be NN or C1.
    - Any option code is available.

**Upper limit of process temperature on the SC210G**

| Analyzer used in combination<br>Ambient temperature Ta<br>Temperature class | FLXA202/FLXA21 |      |
|---|----------------|------|
|   | 40°C           | 60°C |
| T6  | 30             | 30   |
| T5  | 95 (*1)        | 35   |
| T4  | 105            | 45   |
| T3  | 105            | 65   |
| T2  | 105            | 105  |
| T1  | 105            | 105  |

\*1: Care about upper limit 100°C of temperature class T5 should be taken.

**Upper limit of process temperature on the SC4AJ**

| Analyzer used in combination<br>Ambient temperature Ta<br>Temperature class | FLXA202/FLXA21 |      |
|---|----------------|------|
|   | 40°C           | 60°C |
| T6  | 49             | 49   |
| T5  | 95 (*1)        | 64   |
| T4  | 110            | 99   |
| T3  | 110            | 110  |
| T2  | 110            | 110  |
| T1  | 110            | 110  |

\*1: Care about upper limit 100°C of temperature class T5 should be taken.

Other warnings are provided in the user's manual.

**■ Applicable analyzer with various detectors**

| Detector                   | SC4AJ |         |         | SC8SG |         |         | SC210G |         |         |
|----------------------------|-------|---------|---------|-------|---------|---------|--------|---------|---------|
|                            | Pin   | Ring M4 | Ring M3 | Pin   | Ring M4 | Ring M3 | Pin    | Ring M4 | Ring M3 |
| Type of terminals          | Pin   | Ring M4 | Ring M3 | Pin   | Ring M4 | Ring M3 | Pin    | Ring M4 | Ring M3 |
| Converter: FLXA402, SC450G | (*1)  | N.A.    | Yes     | (*1)  | N.A.    | Yes     | (*1)   | N.A.    | Yes     |
| Analyzer: FLXA202, FLXA21  | Yes   | Yes     | N.A.    | Yes   | Yes     | N.A.    | Yes    | Yes     | N.A.    |

\*1: Both pin and M3 ring can be used, but M3 ring are recommended.

## MODEL AND SUFFIX CODES

### 1. SC4AJ

| Model              | Suffix Code   | Option Code  | Description  |
|--------------------|---|--|--|
| SC4AJ              |   |  | Conductivity sensor  |
| Material           | -T<br>-S  |  | Titanium (Only for -AD)<br>316L SS   |
| Fitting type       | -AD<br>-SA<br>-SB<br>-SC  |  | Adapter mounting type<br>Welding socket type (*1)<br>1 or 1.5 inch welding clamp type (*2)<br>2 inch welding clamp type (*2)   |
| Sensor length      | -09<br>-15<br>-NN   |  | 9 cm (Code for -AD)<br>15 cm (Code for -AD)<br>fixed length (Code for -SA, -SB, -SC)   |
| Cell constant      | -002<br>-010  |  | 0.02 cm <sup>-1</sup><br>0.1 cm <sup>-1</sup>  |
| Cable length       | -03<br>-05<br>-10<br>-15<br>-20<br>-X1<br>-X2<br>-X3<br>-X4<br>-X5<br>-Y1<br>-Y2<br>-Y3<br>-Y4<br>-Y5 |  | 3 m (pin terminals)<br>5 m (pin terminals)<br>10 m (pin terminals)<br>15 m (pin terminals)<br>20 m (pin terminals)<br>3 m (M4 ring terminals) (*4)<br>5 m (M4 ring terminals) (*4)<br>10 m (M4 ring terminals) (*4)<br>15 m (M4 ring terminals) (*4)<br>20 m (M4 ring terminals) (*4)<br>3 m (M3 ring terminals) (*4)<br>5 m (M3 ring terminals) (*4)<br>10 m (M3 ring terminals) (*4)<br>15 m (M3 ring terminals) (*4)<br>20 m (M3 ring terminals) (*4) |
| Temperature sensor | -T1   |  | Pt1000   |
| Option             | For AD only<br>For SA only<br>For SB only<br>For SC only<br>Oil prohibit                              | /PS<br>/PF<br>/RS<br>/RF<br>/SA1<br>/SA2<br>/SB1<br>/SB2<br>/SC1<br>/DG1 | 3/4NPT adapter 316 SS<br>3/4NPT adapter PVDF<br>R3/4 adapter 316 SS<br>R3/4 adapter PVDF<br>Straight welding socket 316L SS<br>Angled welding socket 15° 316L SS<br>Welding clamp 1 inch 316L SS<br>Welding clamp 1.5 inch 316L SS<br>Welding clamp 2 inch 316L SS<br>Oil-prohibited use (*3)  |

- \*1: When you select fitting type -SA, place an order on the SC4AJ with option code /SA1 or /SA2.  
 \*2: When you select fitting type -SB, place an order on the SC4AJ with option code /SB1 or /SB2 (including seal ring),  
 When you select fitting type -SC, place an order on the SC4AJ with option code /SC1 (including seal ring).  
 \*3: Washing treatment of wet part with alcohol.  
 \*4: Used for connection to FLXA202, FLXA21.  
 \*5: Used for connection to FLXA402, SC450G.

### Spare parts for SC4AJ

| Parts No. | Description                                    |
|-----------|--|
| K9670MA   | O-ring set for -SA                             |
| K9670MK   | Seal rings for /SB1 or /SB2                    |
| K9670MP   | Seal rings for /SC1                            |
| K9670MT   | 3/4 NPT Stainless steel adapter for -AD        |
| K9670MU   | 3/4 NPT PVDF Adapter for -AD                   |
| K9670MV   | R3/4 Stainless steel adapter for -AD           |
| K9670MW   | R3/4 PVDF Adapter for -AD                      |
| K9670MD   | Angled welding socket and mounting nut for -SA |
| K9670ME   | Straight welding socket for -SA                |
| K9670MB   | Angled welding socket for -SA                  |
| K9670MC   | Straight welding socket for -SA                |
| K9670ML   | Welding clamp 1 or 1.5 inch for -SB            |
| K9670MQ   | Welding clamp 2 inch for -SC                   |

## 2. SC8SG

| Model                   | Suffix Code  | Option Code   | Description  |
|-------------------------|--|---|--|
| <b>SC8SG</b>            | .....  | .....   | Conductivity detector  |
| Measuring range         | <b>-R31</b><br><b>-R61</b>   | .....<br>.....  | Low range; cell constant: 0.01 cm <sup>-1</sup><br>High range; cell constant: 10 cm <sup>-1</sup>  |
| Electrode configuration | <b>-T</b><br><b>-F</b>   | .....<br>.....  | 2-electrode system (for both 0.01 cm <sup>-1</sup> and 10cm <sup>-1</sup> cell constants)<br>- for general measurements (*1)<br>4-electrode system (for 10 cm <sup>-1</sup> cell constant only)<br>- for countermeasures against polarization due to contamination (*2)  |
| Construction            | Screw-in type  | <b>-100</b><br><b>-101</b>  | .....<br>.....   |
|                         | Flow-through type (*7)   | <b>-302</b>   | .....  |
|                         |  | <b>-312</b>   | .....  |
|                         |  | <b>-303</b>   | .....  |
|                         |  | <b>-313</b>   | .....  |
|                         |  | <b>-304</b>   | .....  |
|                         |  | <b>-314</b>   | .....  |
|                         | <b>-305</b>  | .....   |  |
|                         | <b>-315</b>  | .....   |  |
| Cable length            | <b>-P1</b><br><b>-P2</b><br><b>-P3</b><br><b>-F1</b><br><b>-F2</b><br><b>-F3</b><br><b>-X1</b><br><b>-X2</b><br><b>-X3</b><br><b>-Y1</b><br><b>-Y2</b><br><b>-Y3</b> | .....<br>.....<br>.....<br>.....<br>.....<br>.....<br>.....<br>.....<br>.....<br>.....<br>.....<br>.....<br>..... | 5.5 m (special cable supplied with detector) (pin terminals)<br>10 m (special cable supplied with detector) (pin terminals)<br>20 m (special cable supplied with detector) (pin terminals)<br>5.5 m (special cable supplied with detector) (fork terminal)<br>10 m (special cable supplied with detector) (fork terminal)<br>20 m (special cable supplied with detector) (fork terminal)<br>5.5 m (special cable supplied with detector) (M4 ring terminal) (*4)<br>10 m (special cable supplied with detector) (M4 ring terminal) (*4)<br>20 m (special cable supplied with detector) (M4 ring terminal) (*4)<br>5.5 m (special cable supplied with detector) (M3 ring terminal) (*5)<br>10 m (special cable supplied with detector) (M3 ring terminal) (*5)<br>20 m (special cable supplied with detector) (M3 ring terminal) (*5) |
| Style code              | <b>*A</b>  | .....   | Style A  |
| Option                  |  | <b>/PS</b><br><b>/SS</b>  | Stainless Steel Mounting hardware (for PP chamber)<br>Stainless Steel Mounting hardware (for SCS14 chamber)  |

\*1: The cell constant is 0.01 cm<sup>-1</sup> when the combination of measuring range -R31 and Electrode configuration -T is chosen.

The cell constant is 10 cm<sup>-1</sup> when the combination of measuring range -R61 and Electrode configuration -T is chosen.

\*2: Electrode configuration -F cannot be chosen when -R31 is chosen. For process where can give contamination to a detector, a four-electrode detector, the combination of -R61 and -F, should be used.

\*3: If a welding socket (K9208BK) needs to be ordered beforehand, either place a separate order or prepare one by referring to the external view later in this brochure.

\*4: Used for connection to FLXA202, FLXA21.

\*5: Used for connection to FLXA402, SC450G.

\*6: The model is not equipped with a mounting hardware, please place an order on the SC8SG with option code /PS or /SS when you select flow-through model.

The PP chamber can have cracks or splits unless it is not supported by a mounting hardware.

### Spare Parts for SC8SG

| Parts No. | Description   |
|-----------|---|
| K9208BA   | 0.01 cm <sup>-1</sup> cell constant, two-electrode sensor |
| K9208BC   | 10 cm <sup>-1</sup> cell constant, two-electrode sensor   |
| K9208BD   | 10 cm <sup>-1</sup> cell constant, four-electrode sensor  |
| K9208BK   | Welding socket for screw-in model                         |
| G9303EB   | O-ring  |

## 3. WU41

| Model        | Suffix code                                      | Option code                      | Description   |
|--------------|--|----------------------------------|---|
| <b>WU41</b>  | .....  | .....                            | Dedicated Cable for SC8SG   |
| Cable end    | <b>-F</b><br><b>-P</b><br><b>-X</b><br><b>-Y</b> | .....<br>.....<br>.....<br>..... | fork terminals<br>pin terminals<br>M4 ring terminals (*1)<br>M3 ring terminals (*2) |
| Cable length | <b>-05</b><br><b>-10</b><br><b>-20</b>           | .....<br>.....<br>.....          | 5.5 m<br>10 m<br>20 m   |

\*1: Used for connection to FLXA202, FLXA21.

\*2: Used for connection to FLXA402, SC450G

## 4. SC210G

| Model           | Suffix Code            | Option Code   | Description   |
|-----------------|------------------------|---|---|
| <b>SC210G</b>   | .....                  | .....   | Conductivity detector   |
| Measuring range | <b>-A</b>              | .....   | Low range; cell constant: 0.05 cm <sup>-1</sup>   |
|                 | <b>-B</b>              | .....   | Medium range; cell constant: 5 cm <sup>-1</sup>   |
| Construction    | Screw-in type          | <b>-100</b>   | ..... R1-1/2  |
|                 |                        | <b>-103</b>   | ..... 1-1/2NPT male   |
|                 | Flange type            | <b>-206</b>   | ..... JIS 10K 50 RF flange  |
|                 |                        | <b>-207</b>   | ..... ANSI Class150 2 RF flange (with serration)  |
|                 |                        | <b>-208</b>   | ..... JPI Class150 2 RF flange  |
|                 | Flow-through type (*1) | <b>-302</b>   | ..... Rc1/2 female, chamber material: SCS14   |
|                 |                        | <b>-312</b>   | ..... Rc1/2 female, chamber material: PP  |
|                 |                        | <b>-303</b>   | ..... 1/2NPT female, chamber material: SCS14  |
|                 |                        | <b>-313</b>   | ..... 1/2NPT female, chamber material: PP   |
|                 |                        | <b>-304</b>   | ..... JIS 10K 15 RF flange, chamber material: SCS14   |
|                 |                        | <b>-314</b>   | ..... JIS 10K 15 FF flange, chamber material: PP  |
|                 |                        | <b>-305</b>   | ..... ANSI Class150 1/2 RF flange with serration, chamber material: SCS14   |
|                 | With gate valve        | <b>-315</b>   | ..... ANSI Class150 1/2 FF flange, chamber material: PP   |
| <b>-306</b>     |                        | ..... JPI Class150 1/2 RF flange, chamber material: SCS14   |   |
| <b>-402</b>     |                        | ..... R1-1/4  |   |
| <b>-403</b>     |                        | ..... 1-1/4NPT male   |   |
| Sensor length   | <b>-L015</b>           | .....   | 150 mm (Standard)   |
|                 | <b>-L030</b>           | .....   | 300 mm (*2)   |
|                 | <b>-L050</b>           | .....   | 500 mm (*2)   |
|                 | <b>-L100</b>           | .....   | 1000 mm (*2)  |
|                 | <b>-L150</b>           | .....   | 1500 mm (*2)  |
|                 | <b>-L200</b>           | .....   | 2000 mm (*2)  |
| Cable length    | <b>-03</b>             | .....   | 3 m (M4 ring terminals) (*3)  |
|                 | <b>-05</b>             | .....   | 5 m (M4 ring terminals) (*3)  |
|                 | <b>-10</b>             | .....   | 10 m (M4 ring terminals) (*3)   |
|                 | <b>-15</b>             | .....   | 15 m (M4 ring terminals) (*3)   |
|                 | <b>-20</b>             | .....   | 20 m (M4 ring terminals) (*3)   |
|                 | <b>-AA</b>             | .....   | 3 m (pin terminals)   |
|                 | <b>-BB</b>             | .....   | 5 m (pin terminals)   |
|                 | <b>-CC</b>             | .....   | 10 m (pin terminals)  |
|                 | <b>-DD</b>             | .....   | 15 m (pin terminals)  |
|                 | <b>-EE</b>             | .....   | 20 m (pin terminals)  |
|                 | <b>-Y1</b>             | .....   | 3 m (M3 ring terminals) (*4)  |
|                 | <b>-Y2</b>             | .....   | 5 m (M3 ring terminals) (*4)  |
|                 | <b>-Y3</b>             | .....   | 10 m (M3 ring terminals) (*4)   |
|                 | <b>-Y4</b>             | .....   | 15 m (M3 ring terminals) (*4)   |
|                 | <b>-Y5</b>             | .....   | 20 m (M3 ring terminals) (*4)   |
| Style code      | <b>*A</b>              | .....   | Style A   |
| Option          |                        | <b>/SCT</b><br><b>/ANSI</b><br><b>/PF</b><br><b>/PS</b><br><b>/SS</b><br><b>/X1</b><br><b>/DG1</b><br><b>/MCT</b> | Stainless steel tag plate<br>With ANSI connection adaptor (*5)<br>DAI-ELperfrow (perfluoro-elastomer) specification (*6)<br>SUS mounting hardware (for PP construction)<br>SUS mounting hardware (for SCS14 construction)<br>Epoxy-coated (baked)<br>Oil-prohibited use (Degrease cleaning treatment)<br>(except for the type with gate valve)<br>Material Certificate (*7) (except for gate valve) |

\*1: The model is not equipped with a mounting brackets, place an order on the SC210G with option code /PS or /SS when you select flow-through model. The PP chamber material can have cracks or splits unless it is not supported by a mounting hardware.

\*2: Only for Screw-in type and Flange type

\*3: Used for connection to FLXA202, FLXA21.

\*4: Used for connection to FLXA402, SC450G.

\*5: Adaptor for cable inlet (carbon steel)

\*6: Materials for O-ring of electrode assembly and chamber seal become perfluoro-elastomer. But, in construction -402 and -403, the sealing part of gate valve doesn't become the elastomer.

\*7: Additional lead time is required.

## Spare Parts for SC210G

| Name                                      | Part No.  | Remarks  |
|---|---|--|
| Electrode Assembly (*1)<br>(for SC210G-A) | K9208EA   | 150 mm (C=0.05cm <sup>-1</sup> )   |
|   | K9208EB   | 500 mm (C=0.05cm <sup>-1</sup> )   |
|   | K9208EC   | 1000 mm (C=0.05cm <sup>-1</sup> )  |
|   | K9208ED   | 1500 mm (C=0.05cm <sup>-1</sup> )  |
|   | K9208EE   | 2000 mm (C=0.05cm <sup>-1</sup> )  |
|   | K9208EF   | 300 mm (C=0.05cm <sup>-1</sup> )   |
|   | K9315NA   | 150 mm (C=0.05cm <sup>-1</sup> ) with perfluoro-elastomer  |
|   | K9315NB   | 300 mm (C=0.05cm <sup>-1</sup> ) with perfluoro-elastomer  |
|   | K9315NC   | 500 mm (C=0.05cm <sup>-1</sup> ) with perfluoro-elastomer  |
|   | K9315ND   | 1000 mm (C=0.05cm <sup>-1</sup> ) with perfluoro-elastomer   |
|   | K9315NE   | 1500 mm (C=0.05cm <sup>-1</sup> ) with perfluoro-elastomer   |
|   | K9315NF   | 2000 mm (C=0.05cm <sup>-1</sup> ) with perfluoro-elastomer   |
|   | Electrode Assembly (*2)<br>(for SC210G-A with gate valve) | K9208KA  |
| K9315NN                                   |   | (C=0.05cm <sup>-1</sup> ) with perfluoro-elastomer   |
| Electrode Assembly (*1)<br>(for SC210G-B) | K9208JA   | 150 mm (C=5cm <sup>-1</sup> ) (for Construction except Flow-through type*3)                          |
|   | K9208JH   | 150 mm (C=5cm <sup>-1</sup> ) (for Flow-through type *3)   |
|   | K9208JF   | 300 mm (C=5cm <sup>-1</sup> )  |
|   | K9208JB   | 500 mm (C=5cm <sup>-1</sup> )  |
|   | K9208JC   | 1000 mm (C=5cm <sup>-1</sup> )   |
|   | K9208JD   | 1500 mm (C=5cm <sup>-1</sup> )   |
|   | K9208JE   | 2000 mm (C=5cm <sup>-1</sup> )   |
|   | K9315NG   | 150 mm (C=5cm <sup>-1</sup> ) with perfluoro-elastomer (for Construction except Flow-through type*3) |
|   | K9208JJ   | 150 mm (C=5cm <sup>-1</sup> ) with perfluoro-elastomer (for Flow-through type *3)                    |
|   | K9315NH   | 300 mm (C=5cm <sup>-1</sup> ) with perfluoro-elastomer   |
|   | K9315NJ   | 500 mm (C=5cm <sup>-1</sup> ) with perfluoro-elastomer   |
|   | K9315NK   | 1000 mm (C=5cm <sup>-1</sup> ) with perfluoro-elastomer  |
|   | K9315NL   | 1500 mm (C=5cm <sup>-1</sup> ) with perfluoro-elastomer  |
|   | K9315NM   | 2000 mm (C=5cm <sup>-1</sup> ) with perfluoro-elastomer  |
|   | Electrode Assembly (*2)<br>(for SC210G-B with gate valve) | K9208MA  |
| K9315NP                                   |   | (C=5cm <sup>-1</sup> ) with perfluoro-elastomer  |
| Cable                                     | K9315QA   | 3 m (M4 ring terminals, SC210G...-03)  |
|   | K9315QB   | 5 m (M4 ring terminals, SC210G...-05)  |
|   | K9315QC   | 10 m (M4 ring terminals, SC210G...-10)   |
|   | K9315QF   | 15 m (M4 ring terminals, SC210G...-15)   |
|   | K9315QG   | 20 m (M4 ring terminals, SC210G...-20)   |
|   | K9315QR   | 3 m (pin terminals)  |
|   | K9315QS   | 5 m (pin terminals)  |
|   | K9315QT   | 10 m (pin terminals)   |
|   | K9315QU   | 15 m (pin terminals)   |
|   | K9315QV   | 20 m (pin terminals)   |
|   | K9315QJ   | 3 m (M3 ring terminals)  |
|   | K9315QK   | 5 m (M3 ring terminals)  |
|   | K9315QL   | 10 m (M3 ring terminals)   |
|   | K9315QM   | 15 m (M3 ring terminals)   |
|   | K9315QQ   | 20 m (M3 ring terminals)   |
| O-ring                                    | K9050AT   | Fluoro-rubber (FKM) O-ring (for screw-in type, flange type and flow-through type)                    |
|   | K9050MR   | Fluoro-rubber (FKM) O-ring (for gate valve type)   |
|   | K9319RN   | Perfluoro-elastomer O-ring (for all types)   |

\*1: For the electrode assembly for oil-prohibited use (/DG1) and/or with material certificate (/MCT), please contact Yokogawa.

\*2: For the electrode assembly with material certificate (/MCT), please contact Yokogawa.

\*3: K9208JA or K9315NG can be attached to Flow-through type, but Yokogawa recommends K9208JH or K9208JJ instead.

## DIMENSIONS

### 1. SC4AJ

<Adapter mounting type>

SC4AJ-□-AD-09

Sensor length: 09 (9 cm)

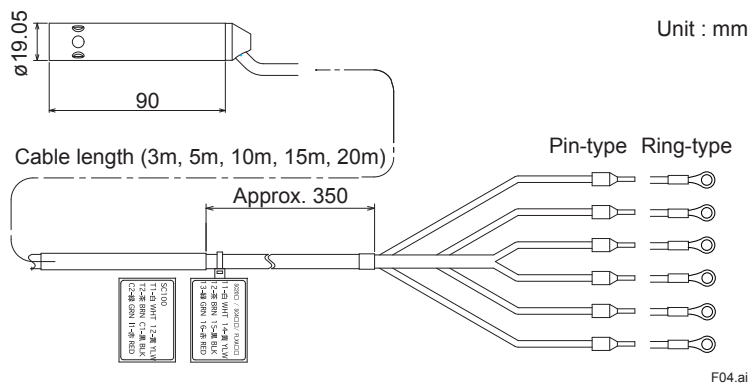

SC4AJ-□-AD-15

Sensor length: 15 (15 cm)

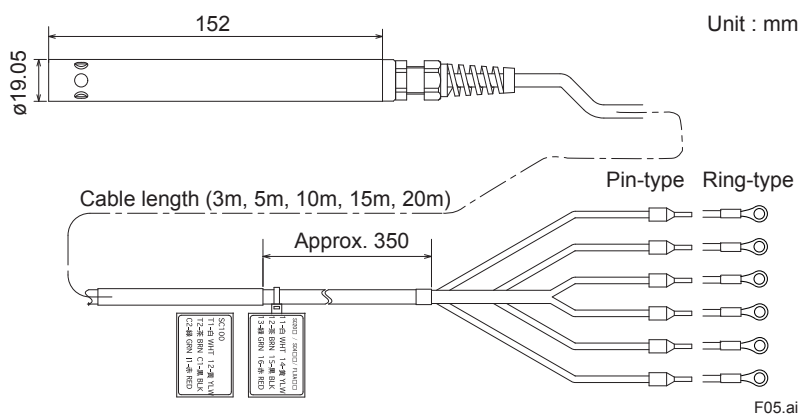

• Option: Adapter mounting type (-AD)

/PS (Stainless Steel)  
/RS (Stainless Steel)

/PF (PVDF)  
/RF (PVDF)

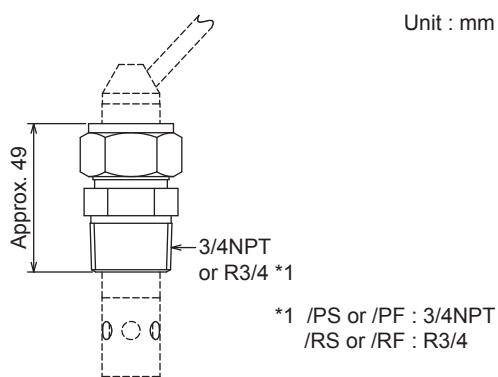

\*1 /PS or /PF : 3/4NPT  
/RS or /RF : R3/4



**<Welding clamp type>  
SC4AJ-□-SB-NN**

Unit : mm

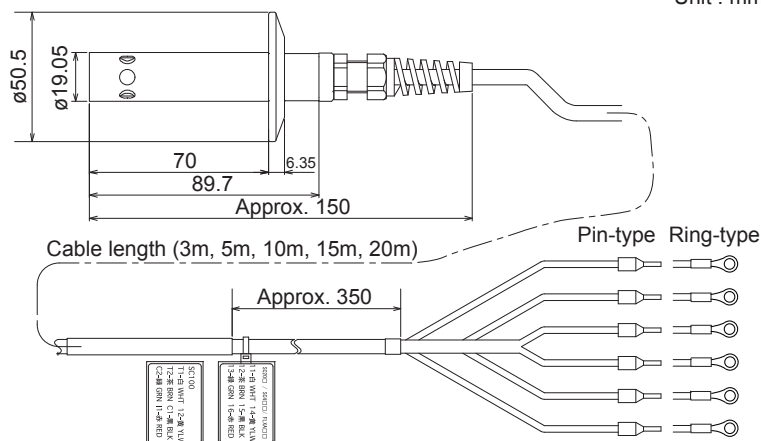

F09.ai

● Option: Welding clamp type (-SB)

Unit : mm

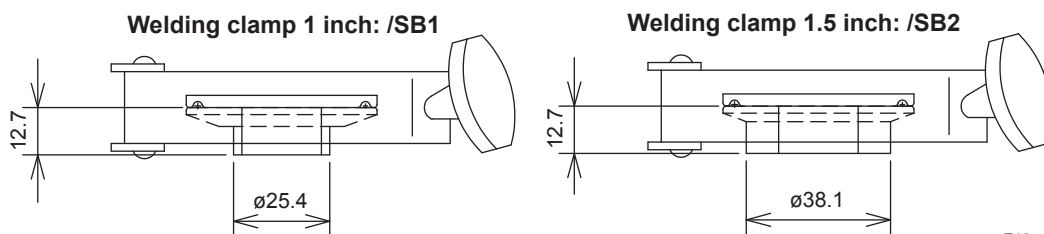

F10.ai

**Sensor SC4AJ-□-SC-NN**

Unit : mm

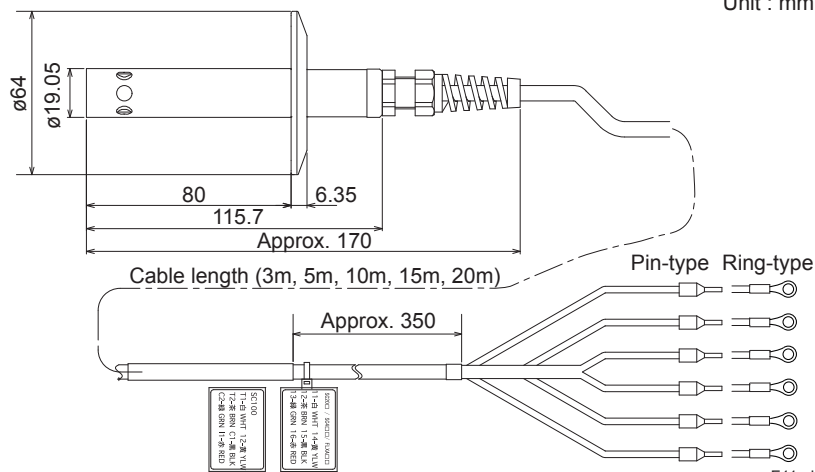

F11.ai

● Option: Welding clamp type (-SC)

Unit : mm

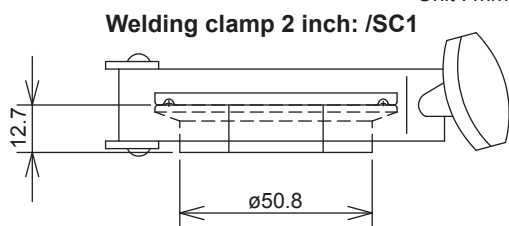

F12.ai

## 2. SC8SG

### <Screw-in type>

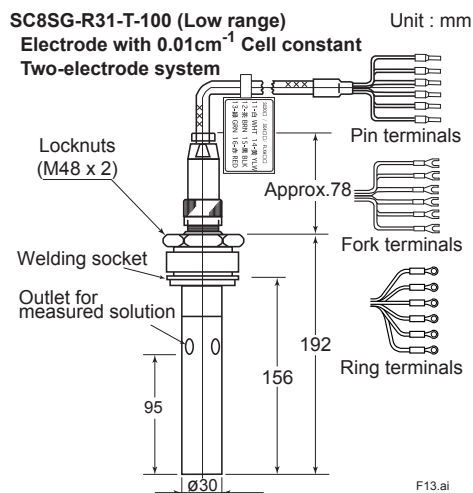

### Welding socket Parts No: K9208BK

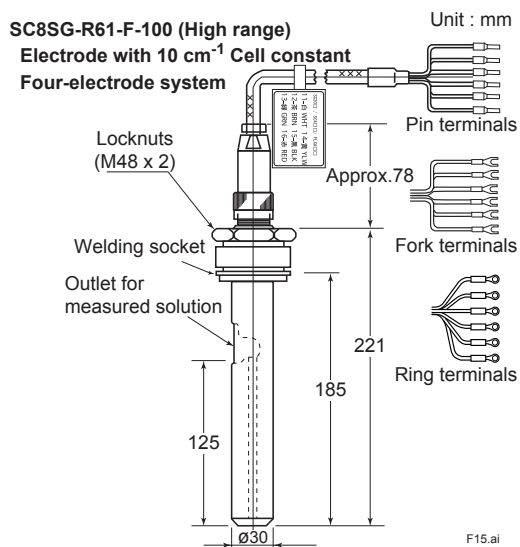
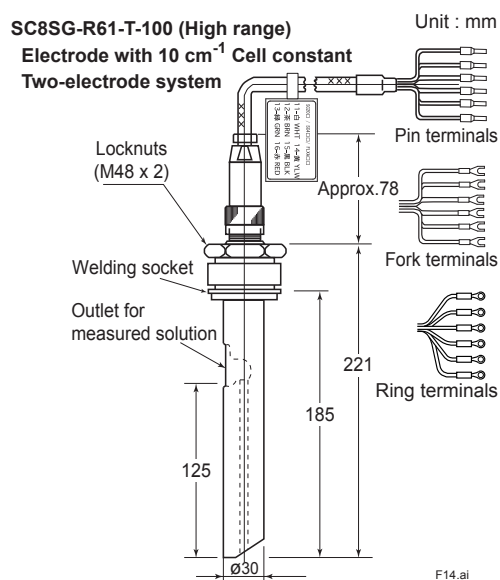
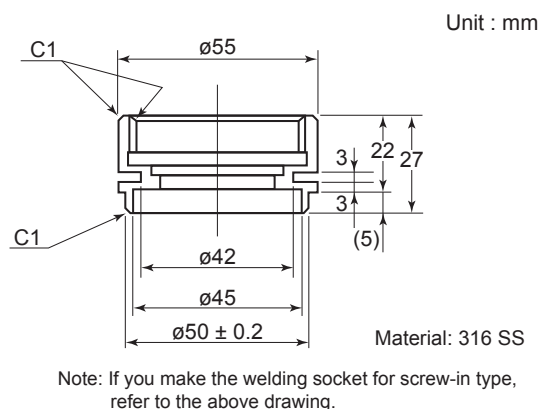

**<Flow-through type>**  
**SC8SG-R□1-□-302,**  
**SC8SG-R□1-□-303,**  
**Screw connection (Chamber Material: SCS14)**

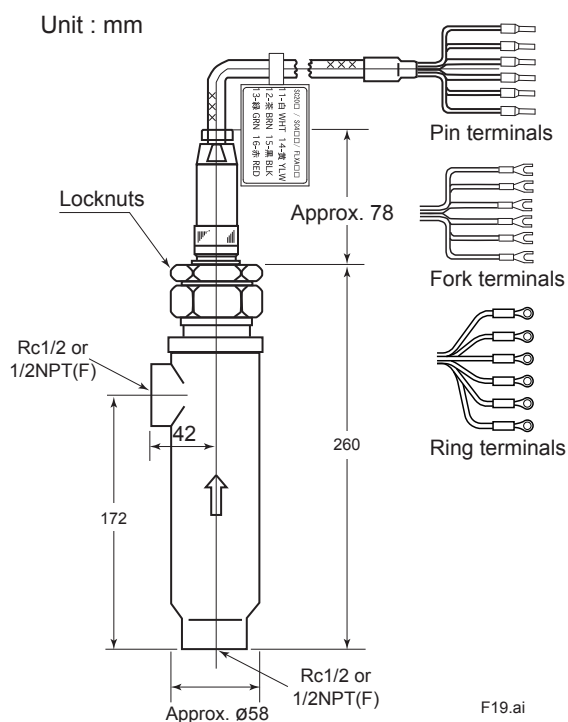

● Option: Mounting hardware (-SS)

Unit : mm

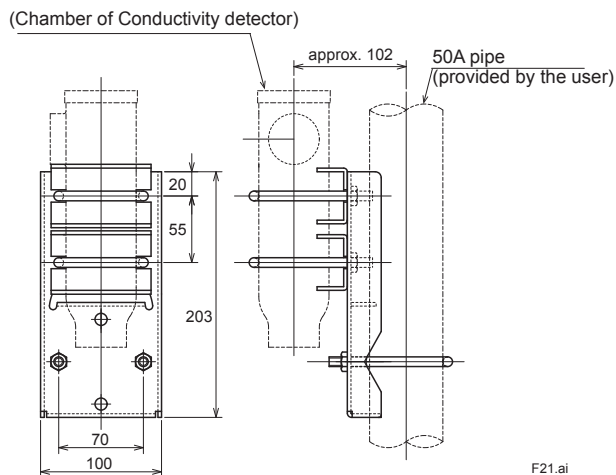

**SC8SG-R□1-□-304,**  
**SC8SG-R□1-□-305,**  
**Flange connection (Chamber Material: SCS14)**

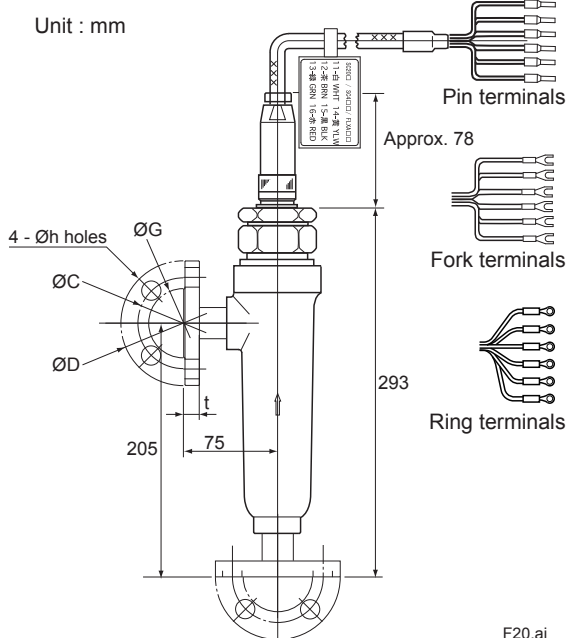

| Flange rating                            | $\phi$ C | $\phi$ D | $\phi$ G | $\phi$ h | t    |
|--|----------|----------|----------|----------|------|
| JIS 10K 15 RF                            | 70       | 95       | 52       | 15       | 12   |
| ANSI Class150 1/2 RF<br>(with serration) | 60.5     | 88.9     | 34.9     | 15.7     | 11.2 |

**SC8SG-R□1-□-312, SC8SG-R□1-□-313,  
Screw connection (Chamber Material: PP) + Option (Mounting hardware (/PS))**

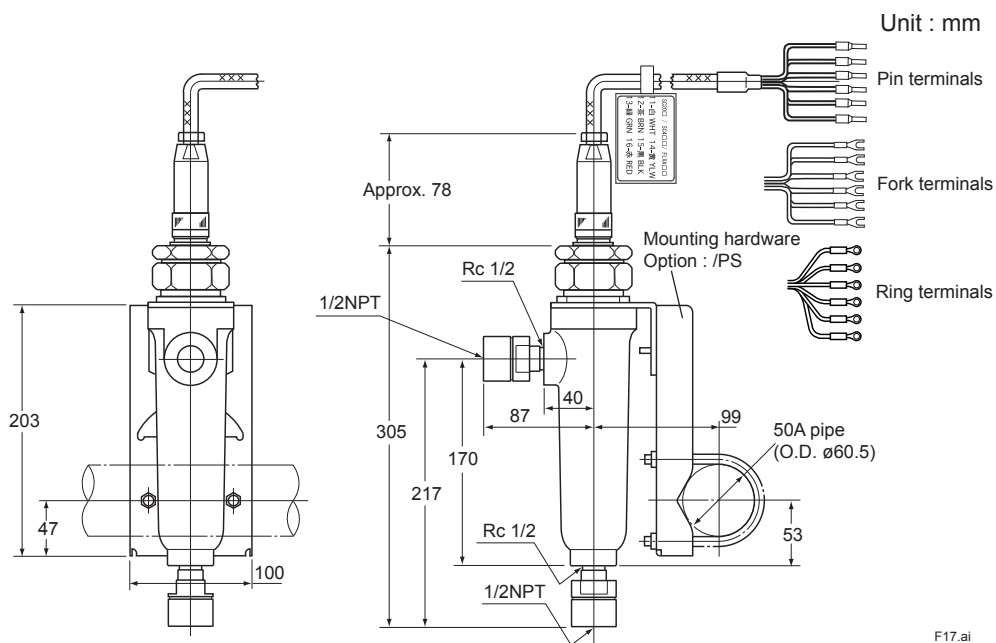

**SC8SG-R□1-□-314, SC8SG-R□1-□-315,  
Flange connection (Chamber Material: PP) + Option (Mounting hardware (/PS))**

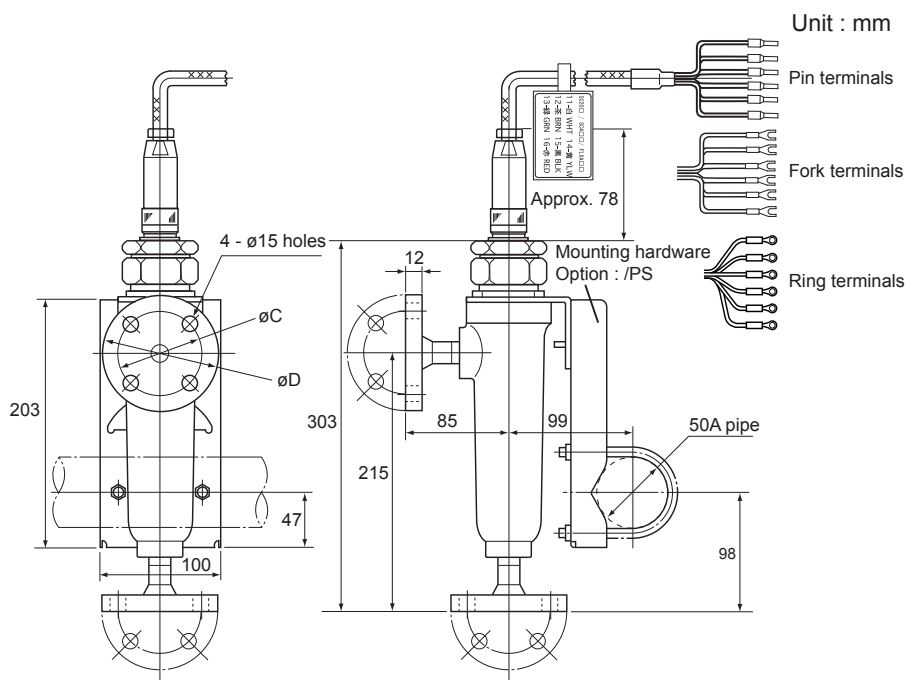

| Flange rating        | øC   | øD   |
|----------------------|------|------|
| JIS 10K 15 FF        | 70   | 95   |
| ANSI Class150 1/2 FF | 60.5 | 88.9 |

F18.ai



**<Flange Type>**  
**SC210G-□-206, SC210G-□-207, SC210G-□-208**

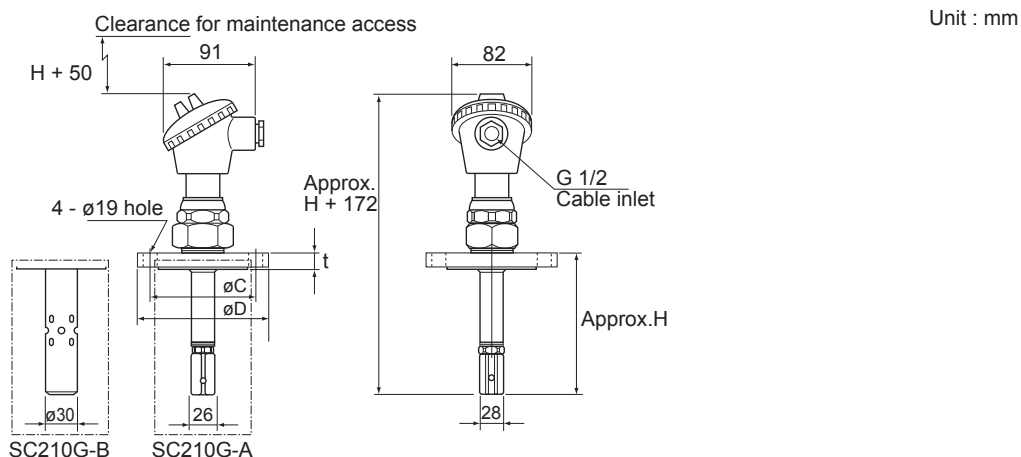

**<Flange>**

| Sensor length code     | Flange rating      | øC    | øD    | t    |
|------------------------|--------------------|-------|-------|------|
| SC210G-□-206-L□□□-□□*A | JIS 10K 50 RF      | 120   | 155   | 16   |
| SC210G-□-207-L□□□-□□*A | ANSI Class150 2 RF | 120.7 | 152.4 | 19.1 |
| SC210G-□-208-L□□□-□□*A | JPI Class150 2 RF  | 120.6 | 152   | 19.5 |

Note : ANSI flange with serrations.

**<Sensor length>**

| Sensor length code     | H    |
|------------------------|------|
| SC210G-□-20□-L015-□□*A | 162  |
| SC210G-□-20□-L030-□□*A | 312  |
| SC210G-□-20□-L050-□□*A | 512  |
| SC210G-□-20□-L100-□□*A | 1012 |
| SC210G-□-20□-L150-□□*A | 1512 |
| SC210G-□-20□-L200-□□*A | 2012 |

F24.ai

**<Flow-through type>**  
**SC210G-□-302, SC210G-□-303 \*1**  
**Screw connection (Chamber Material: SCS14)**

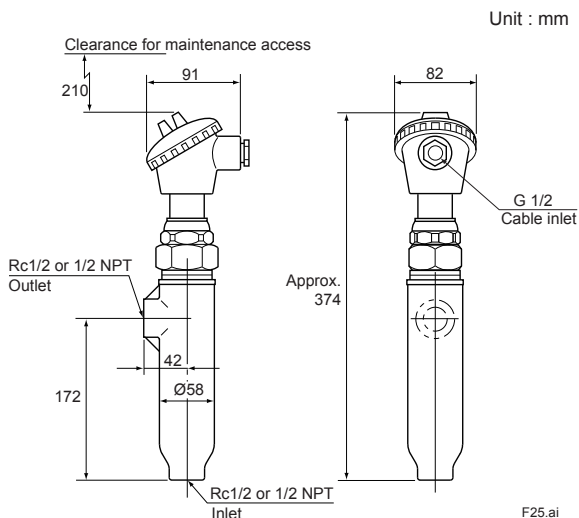

F25.ai

**SC210G-□-312, SC210G-□-313**  
**Screw connection (Chamber Material: PP)**

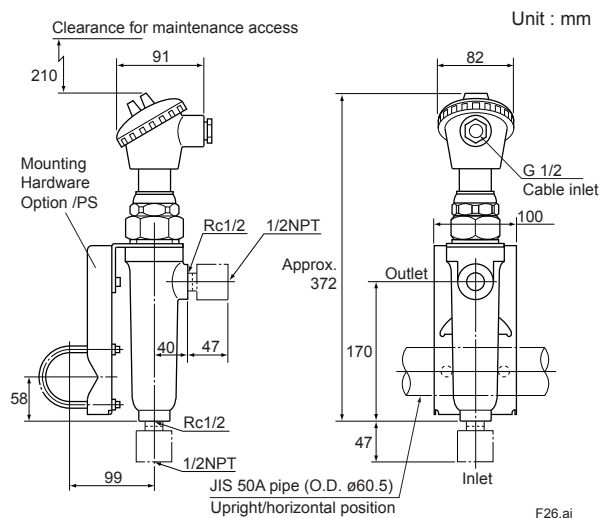

F26.ai

\*1: Dimension and Fitting of Option (Mounting hardware (/SS)) refer to p13.

**SC210G-□-304, SC210G-□-305  
SC210G-□-306**  
Flange connection (Chamber Material: SCS14)

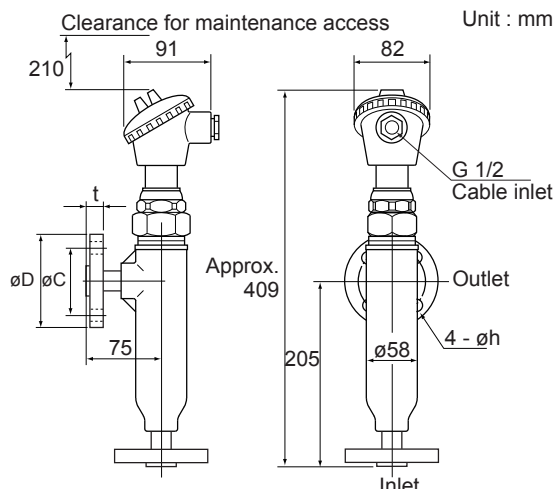

| Flange rating        | øC   | øD   | t    | øh   |
|----------------------|------|------|------|------|
| JIS 10K 15 RF        | 70   | 95   | 12   | 15   |
| ANSI Class150 1/2 RF | 60.5 | 88.9 | 11.2 | 15.7 |
| JPI Class150 1/2 RF  | 60.3 | 89   | 10.9 | 16   |

Note: ANSI flange is serration.

F28.ai

**SC210G-□-314, SC210G-□-315**  
Flange connection (Chamber Material: PP)

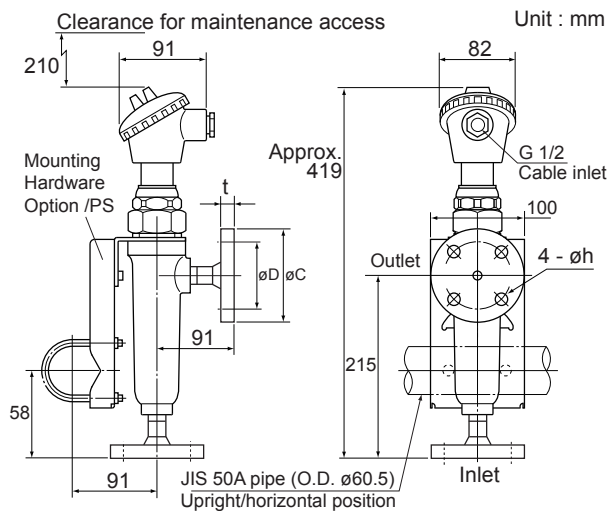

| Flange rating        | øC   | øD   | t  | øh |
|----------------------|------|------|----|----|
| JIS 10K 15 FF        | 70   | 95   | 12 | 15 |
| ANSI Class150 1/2 FF | 60.5 | 88.9 | 12 | 15 |

F27.ai

**<With gate valve>**  
**SC210G-□-402, SC210G-□-403**

SC210G-A (Low range)

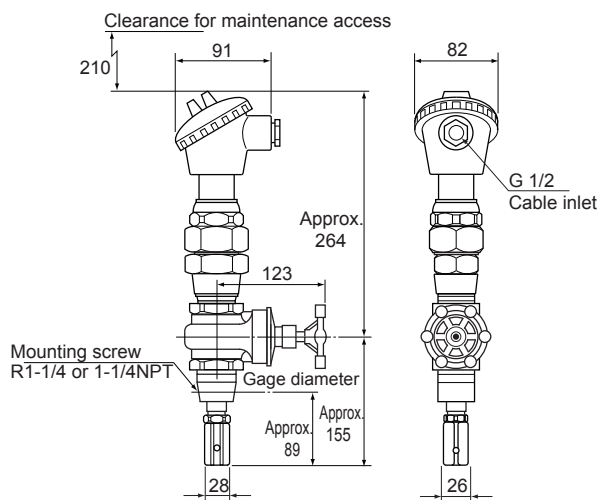

SC210G-B (Medium range)

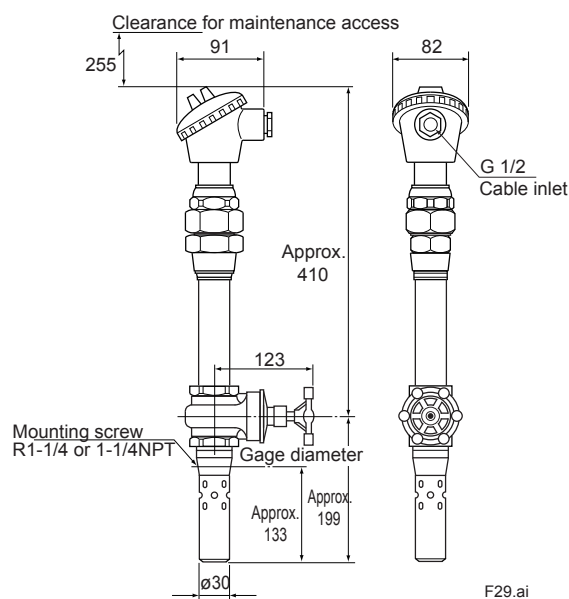

F29.ai

## ■ WIRING DIAGRAM

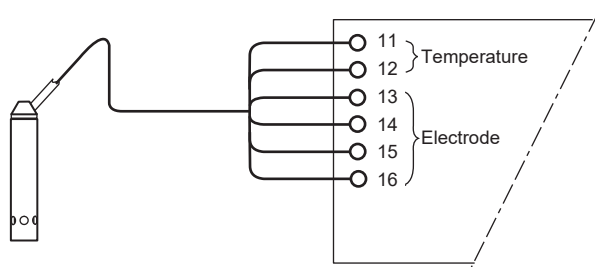

**SC4AJ Conductivity Sensor**  
(two-electrode system)  
Applicable Analyzer:  
FLXA402, SC450G, FLXA202, FLXA21

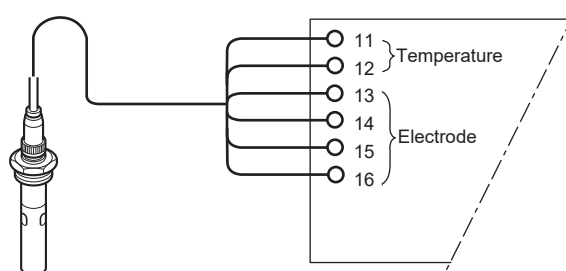

**SC8SG Conductivity Detector**  
(two-electrode system, four-electrode system)  
Applicable Analyzer:  
FLXA402, SC450G, FLXA202, FLXA21

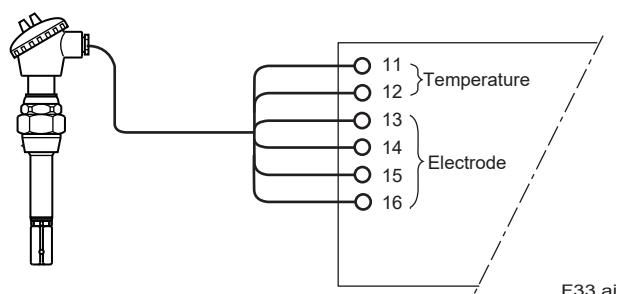

**SC210G Conductivity Detector**  
(two-electrode system)  
Applicable Analyzer:  
FLXA402, SC450G, FLXA202, FLXA21

F33.ai

## ■ TABLE OF CORROSION-RESISTANT MATERIALS

**Note:** This table shows corrosion resistances against each specified chemical only. If two or more kinds of chemical are mixed in a sample, the properties may be different from those shown in this table.

- ◎ Very suitable
- Suitable
- △ Slightly unsuitable
- × Unusable

Example of Description  
Concentration %      Temperature °C

Judgement  
◎

|                 |   | Holder material   |                     |                     | Electrode material  |                                  |             |  | Seal O-ring material |
|-----------------|---|---|---------------------|---------------------|---------------------|----------------------------------|-------------|--|----------------------|
|                 |   | Polypropylene   |                     |                     | 316 SS              |                                  | Epoxy resin |  | PVDF                 |
| Inorganic acids | Hydrochloric acid                                   | 5 20 ◎<br>80 ◎  | 5 30 ×              | 5 30 ○<br>10 60 ×   | 5 30 ◎<br>1 30 ×    | Strong acid ◎<br>Weak acid ◎     |             |  |                      |
|                 | Hypochlorous acid                                   | 10 20 ◎<br>40 ○   | 14 30 ×             | 15 30 ×             | 20 40 ◎             |                                  |             |  |                      |
|                 | Nitric acid   | 10 20 ◎<br>80 ◎   | 10 30 ◎             | 10 30 ◎<br>25 60 ×  | 10 100 ○            |                                  |             |  |                      |
|                 | Sulfuric acid                                       | 3 20 ◎<br>3 100 ◎   | 5 30 ◎<br>5 100 ×   | 5 20 ○<br>10 60 ×   | 5 30 ◎<br>5 100 ×   |                                  |             |  |                      |
|                 | Phosphoric acid                                     | 30 60 ◎<br>30 100 △                                       | 15 30 ◎<br>5 b ◎    | 5 30 ◎<br>25 100 ×  | 5 30 ◎<br>5 60 ○    |                                  |             |  |                      |
| Alkali          | Ammonia water                                       | 15 80 ◎<br>15 100 ○                                       | 10 b ◎<br>28 65 ◎   | 10 b ◎<br>28 65 ◎   | 10 b ◎<br>28 65 ◎   | Strong alkali ×<br>Weak alkali △ |             |  |                      |
|                 | Caustic potash                                      |   | 10 b ◎<br>25 b ◎    | 10 60 ○<br>25 b ×   | 10 b ◎<br>25 b ○    |                                  |             |  |                      |
|                 | Caustic soda  | 20 80 ◎<br>20 100 ◎                                       | 20 30 ◎<br>20 b ◎   | 20 60 ◎<br>20 b ×   | 20 30 ◎<br>20 b ◎   |                                  |             |  |                      |
|                 | Potassium carbonate                                 |   | 5 b ◎<br>35 b ◎     | 5 b ◎<br>35 b ◎     | 5 b ◎<br>35 b ○     |                                  |             |  |                      |
|                 | Sodium carbonate                                    | sat. 100 ◎  | 25 b ◎              | 25 b ◎              | 25 b ◎              |                                  |             |  |                      |
| Chlorides       | Zinc chloride                                       |   | 20 b △              | 20 60 ○             | 20 b ◎              |                                  |             |  |                      |
|                 | Aluminum chloride                                   |   | 25 25 ×<br>25 25 ×  |                     | 10 b ◎<br>25 b ×    |                                  |             |  |                      |
|                 | Ammonium chloride                                   | 35 40 ◎   | 25 b △              | 25 20 ○             | 25 b ◎              |                                  |             |  |                      |
|                 | Potassium chloride                                  |   | sat. 60 ◎           | sat. 60 ◎           | sat. 60 ◎           |                                  |             |  |                      |
|                 | Calcium chloride                                    | sat. 80 ◎<br>sat. 100 ◎                                   | 25 b ○              | 25 b ◎              | 25 b ◎              |                                  |             |  |                      |
|                 | Ferric chloride                                     | 20 40 ◎<br>60 ◎   | 30 b ×              | 30 60 ○<br>100 ×    | 30 b ◎              |                                  |             |  |                      |
|                 | Sodium chloride 20% + C12 (saturated) (Electrolyte) | 100 ◎   | 90 ×                | 90 ×                | 90 ◎                |                                  |             |  |                      |
|                 | Sea water   | 24 ◎  | 24 △                | 60 ○                | 24 ◎                |                                  |             |  |                      |
| Sulfates        | Ammonium sulfate                                    | 5 60 ◎  | 20 b ◎<br>sat. 30 ◎ | 20 b ◎<br>sat. 30 ○ | 20 b ◎<br>sat. 30 ◎ |                                  |             |  |                      |
|                 | Potassium sulfate                                   |   | 10 b ◎              | 10 b ◎              | 10 b ◎              |                                  |             |  |                      |
|                 | Sodium sulfate                                      |   | 20 b ◎              | 20 b ◎              | 20 b ◎              |                                  |             |  |                      |
| Nitrates        | Ammonium nitrate                                    | Good corrosion resistance against all salts normally used | 20 b ◎              | 20 b ◎              | 20 b ◎              |                                  |             |  |                      |
|                 | Sodium nitrate                                      |   | 50 b ◎              | 50 b ◎              | 50 b ◎              |                                  |             |  |                      |
| Others          | Sodium sulfite                                      |   | 20 b ◎              |                     | 20 b ◎              |                                  |             |  |                      |
|                 | Hydrogen peroxide                                   |   | 10 30 ◎             | 10 30 ◎             | 10 30 ◎             |                                  |             |  |                      |
|                 | Sodium hypochlorite                                 | 10 90 ◎<br>20 80 ◎  | 2 60 to 90 ×        | 2 60 to 90 ×        | 15 30 ◎             |                                  |             |  |                      |
|                 | Potassium bichromate                                |   | 10 b ◎              | 10 20 ○             | 10 b ◎              |                                  |             |  |                      |
|                 | Alcohol   | 96 70 ◎   | 100 b ◎             | 80 60 ○             | 80 100 ○            |                                  |             |  |                      |
|                 | Acetic acid   | 100 70 ◎  | 100 70 ◎            | 10 60 ○             | 10 100 ○            |                                  |             |  |                      |
|                 | Phenol  | 100 20 ◎  | 95 30 ◎             | 100 20 ×            | 100 20 ○            |                                  |             |  |                      |
|                 | Aromatic solvent                                    | 100 20 ×  | 100 25 ◎            | 100 20 ×            | 100 ○               |                                  |             |  |                      |

(Note) b: Shows temperatures up to the boiling point. PVDF: Polyvinylidene difluoride

### CAUTION



Select the material of wetted parts with careful consideration of process characteristics. Inappropriate selection may cause leakage of process fluids, which greatly affects facilities. Considerable care must be taken particularly in the case of strongly corrosive process fluid such as hydrochloric acid, sulfuric acid, hydrogen sulfide, and sodium hypochlorite. If you have any questions about the wetted part construction of the product, be sure to contact Yokogawa.

