

■ Standard Performance

Accuracy rating: $\pm 0.1\%$ of span or 0.1°C , whichever is greater; for Pt50, $\pm 0.2\%$ of span or 0.2°C , whichever is greater; accuracy is not guaranteed for output level less than 0.5% of the span of a 0 to X mA output range type.

Response speed: 150 ms, 63% response (10 to 90%)

Burnout function: One of the three options is selected - Up, Down or Off; the maximum burnout time is specified as 60 seconds.

Effects of power line regulation: Up to $\pm 0.1\%$ of span for the regulation within allowable range of each supply voltage range

Effects of ambient temperature variations: Up to $\pm 0.15\%$ of span per 10°C

Effects of leadwire resistance variations: Up to $\pm 0.2^\circ\text{C}$ per $10\ \Omega/\text{leadwire}$

■ Power Supply and Isolation

Supply rated voltage range: 100-240 V AC/DC \approx 50/60 Hz or 15-30 V DC \approx

Supply input voltage range: 100-240 V AC/DC \approx (-15, +10%) 50/60 Hz or 15-30 V DC \approx ($\pm 20\%$)

Power consumption: 2.2 W at 24 V DC ; 2.1 W at 110 V DC; 4.2 VA at 100 V AC; 6.1 VA at 200 V AC

Insulation resistance: 100 M Ω minimum at 500 V DC between input, output-1, output-2, power supply and grounding terminals mutually

Withstanding voltage: 2000 V AC for one minute between input, (output-1 and output-2), power supply and grounding terminals mutually;
1000 V AC for one minute between output-1 and output-2 terminals

■ Environmental Conditions

Operating temperature range: 0 to 50°C

Operating humidity range: 5 to 90% RH (no condensation)

Operating conditions: Avoid installation in such environments as corrosive gas like sulfide hydrogen, dust, sea breeze and direct sunlight.

Installation altitude: 2000 m or less above sea level.

■ Mounting and Appearance

Material: Modified polyphenylene oxide (casing)

Mounting method: Wall, DIN rail or dedicated VJ mounting base (VJCE) mounting

Connection method: M3 screw terminals

External dimensions: 76 (H)x29.5 (W)x124.5 (D) mm (including a socket)

Weight: Approx. 122 g (main unit), approx. 51 g (socket)

■ Accessories

Tag number label: One

■ Customized Signal Specifications

<Input range>

Special RTD with temperature table. The measuring range is between 0 and 2000 Ω in resistance value.

Table 1 Manufacturable Ranges

	Current Signal	Voltage Signal
Output range (DC)	0 to 24 mA	-10 to +10 V
Span (DC)	1 to 24 mA	10 mV to 20 V
Zero elevation	0 to 200%	-100 to +200%

Terminal Assignments

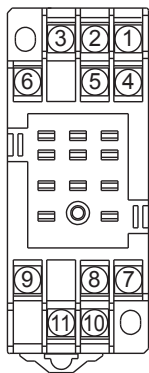

1	INPUT	(A)
2	OUTPUT-2	(+)
3	INPUT	(B)
4	INPUT	(B)
5	OUTPUT-2	(-)
6	N.C.	
7	OUTPUT-1	(+)
8	GND	
9	OUTPUT-1	(-)
10	SUPPLY	(L+)
11	SUPPLY	(N-)

Note: For single-output type, OUTPUT-2 is N.C.

Block Diagram

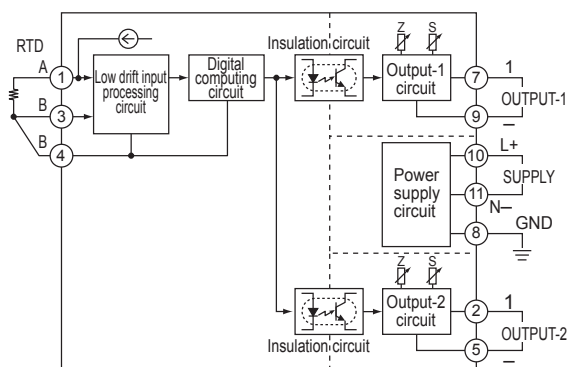

External Dimensions

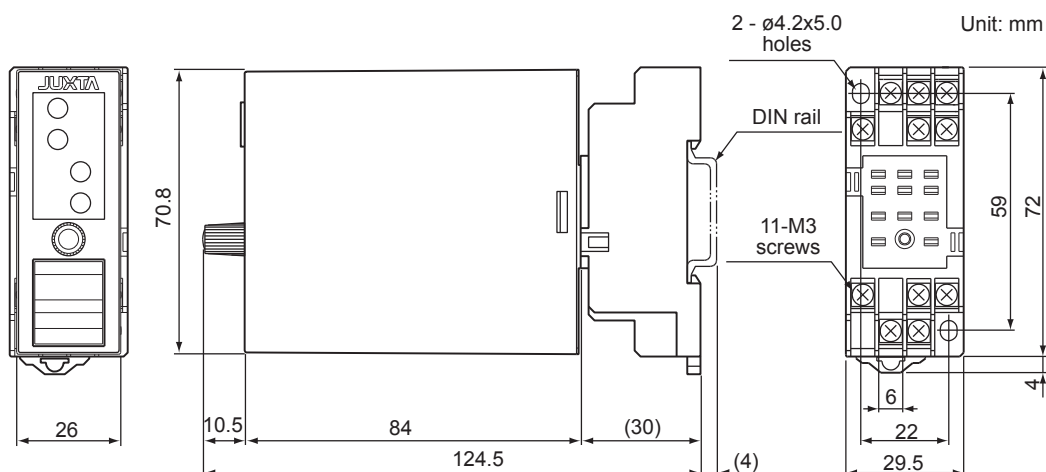

- The information covered in this document is subject to change without notice for reasons of improvements in quality and/or performance.