

General Specifications

Conductivity Detectors/Sensors

GS 12D08G02-E

■ GENERAL

YOKOGAWA has been supplying superior on-line analyzers for monitoring or controlling the conductivity of liquid or solutions.

Now, YOKOGAWA provides the 4-Wire Converter (FLXA™402), the 2-Wire Liquid Analyzer (FLXA™202, FLXA™21).

YOKOGAWA also provides many kinds of detectors/sensors for accurately measuring liquid conductivity when using analyzers.

The combination of YOKOGAWA's analyzers and detectors/sensors meets the demanding ultrapurewater requirements of the growing semiconductor and pharmaceutical markets in addition to traditional water quality measurements for standard power plant and chemical applications.



Refer to GS 12A01F01-01EN



Refer to GS 12A01A02-01E

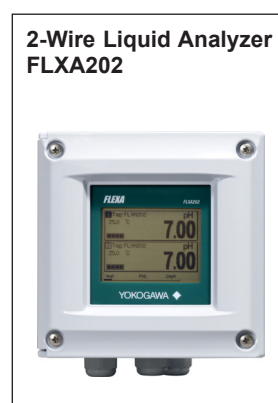

Refer to GS 12A01A03-01EN

FLEXA, FLXA, EXA SC are registered trademarks or trademarks of Yokogawa Electric Corporation.
All other company and product names mentioned in this GS are registered trademarks or trademarks of their respective companies.

Models of Conductivity Detectors/Sensors

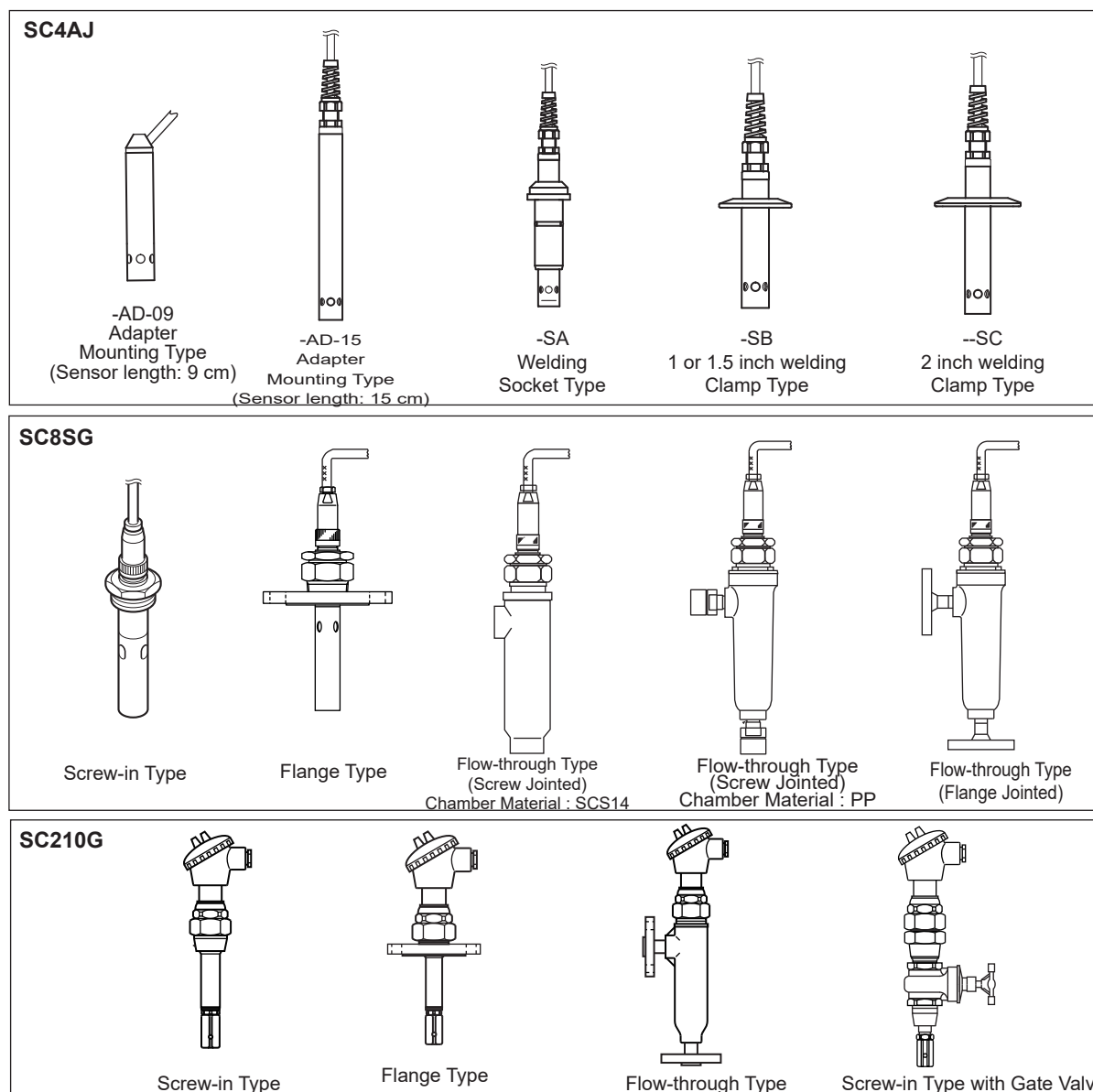

F01.ai

RANGE OF MEASURING UPPER RANGE LIMIT OF EACH SENSORS

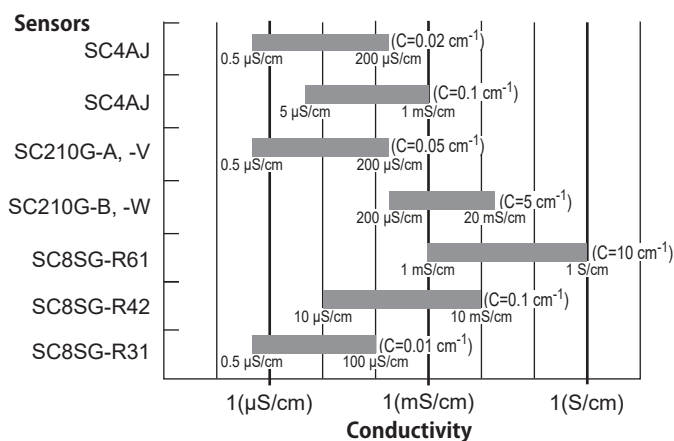

Note

The bar graph at the left shows the range of the upper range limit of each sensor.

For example, in the case of SC8SG-R61, the measuring range is from 0-1 mS/cm to 0-1 S/cm.

In measurement in high conductivity range, polluted solution may affect measured values of any sensors. C represents cell constant.

■ GENERAL SPECIFICATIONS

1. SC4AJ:

- Cable with pin terminals (applicable to FLXA202, FLXA21, FLXA402)
- Cable with M4 ring terminals (applicable to FLXA202, FLXA21)
- Cable with M3 ring terminals (applicable to FLXA402)
- Variopin connector (applicable to SA11)
- Object of measurement: Conductivity of solutions
- Measuring principle: Two-electrode system
- Cell constant: 0.02 cm⁻¹, 0.1 cm⁻¹
- Measuring range:
 - For a cell constant: 0.02 cm⁻¹:
0-0.5 μS/cm to 0-200 μS/cm
 - For a cell constant: 0.1 cm⁻¹:
0-5 μS/cm to 1 mS/cm
- Temperature Range: For electrode, 0 to 110°C
For holder, see Figure 1
- Sterilization for electrode:
135°C (275°F), within 30 minutes in
Steam Sterilization
- Pressure range : For electrode, 0 to 1 MPa
For holder, see Figure 1

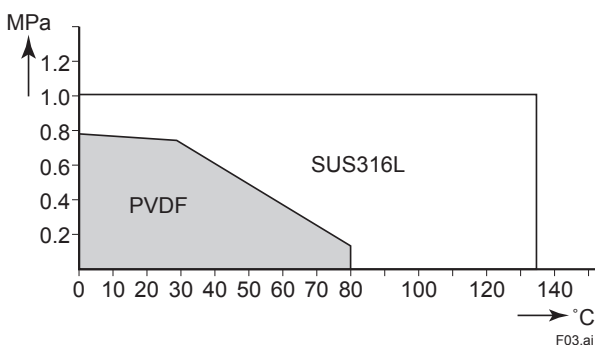

Figure1: The range of tolerance of holders (option: /PS, /PF, /RS, /RF, /SA1, /SA2, /SB1, /SB2, /SC1) for temperature and pressure

- Sample solution condition:
 - Although flow rate is not limited in measurement, air bubbles should not be mixed in the sample solutions to obtain correct measured values.
- Temperature sensor: Pt1000
- Materials: Stainless steel (316L SS) (for all Fitting-type) or Titanium (only for adapter mounting type-AD), Fluoro rubber (FKM) O-ring. EPDM O-ring (for -SA with Variopin)
- Mounting adapter: Polyvinylidene difluoride (for /PF and /RF) or Stainless steel (316 SS), Stainless steel (316L SS)
- Weight:
 - Sensors:
 - Adapter mounting type (SC4AJ-S-AD-09-002-03): approx. 0.3 kg
 - Adapter mounting type (SC4AJ-S-AD-15-002-03): approx. 0.4 kg
 - Welding socket type (SC4AJ-S-SA-NN-002-03): approx. 0.5 kg
 - 1 or 1.5 inch welding clamp type (SC4AJ-S-SB-NN-002-03): approx. 0.4 kg
 - 2 inch welding clamp type (SC4AJ-S-SC-NN-002-03): approx. 0.5 kg

Note: There are weight differences among SC4AJ sensors. In order to know the more accurate weight of each type of sensors, please calculate it from following information. The cable weighs 0.07 kg/m. The SC4AJ with 0.02 cm⁻¹ cell constant is 0.02 kg heavier than the SC4AJ with 0.1 cm⁻¹ cell constant. 316L SS electrode is 0.04 kg heavier than Titanium electrode.

Adapters:

- 3/4NPT stainless steel adapter (/PS): approx. 0.1 kg
- R3/4 stainless steel adapter (/RS): approx. 0.1 kg
- 3/4NPT PVDF adapter (/PF): approx. 0.04 kg
- R3/4 PVDF adapter (/RF): approx. 0.04 kg
- Straight welding socket (/SA1): approx. 0.3 kg
- Angle welding socket 15 (/SA2): approx. 0.3 kg
- Welding clamp 1 inch (/SB1): approx. 0.3 kg
- Welding clamp 1.5 inch (/SB2): approx. 0.3 kg
- Welding clamp 2 inch (/SC1): approx. 0.4 kg

note: Do not submerge the sensor itself in process water, as the seams between the mold and the metal of the sensor are not waterproof.

2. SC8SG:

- Cable with pin terminals (applicable to FLXA202, FLXA21, FLXA402)
- Cable with M4 ring terminals (applicable to FLXA202, FLXA21)
- Cable with M3 ring terminals (applicable to FLXA402)
- Variopin connector (applicable to SA11)
- Object of measurement: Conductivity of liquids
- Measuring Principle: 2-electrode system or 4-electrode system
- Cell Constants: 0.01 cm⁻¹, 0.1 cm⁻¹, 10 cm⁻¹ (for two-electrode system) 10 cm⁻¹ (for four-electrode system)
- Measuring Ranges: 0-0.5 μS/cm to 0-100 μS/cm for a cell constant of 0.01 cm⁻¹ 0-10 μS/cm to 0-10 mS/cm for a cell constant of 0.1 cm⁻¹ 0-1 mS/cm to 0-1000 mS/cm for a cell constant of 10 cm⁻¹
- Temperature Range: 0° to 100°C (130°C maximum only for 0.01 cm⁻¹ cell constant detectors, excluding those with polypropylene chambers)
- Pressure: 1000 kPa max. (500 kPa maximum for detectors with polypropylene chambers)
- Flow rate of Sample Solution: No particular limitation applies, although a value of less than 20 L/min. is recommended for flow-through detectors.
- Note: No limitation applies to flow rate (flow velocity) as far as measurement is concerned. However, when using flow-through detectors, electrodes or the inner walls of a liquid chamber may be worn out drastically at higher flow speeds if a measured solution contains slurry. Air bubbles should not be mixed in the sample solutions to obtain correct measured values.
- RTD for Temperature Compensation: Pt1000 (built into the sensor)
- Construction: Direct insertion (in-situ) type or flow-through types. Rainproof encapsulation (equivalent to JIS C0920 Japanese Industrial Standard)

Installation :

- Screw-in type: held by the process piping
- Flange type: held by the process piping
- Flow-through type (polypropylene chamber)
 - : mounted on a pipe (nominal diameter of 50 mm \pm 2 in.)
- Flow-through type (SCS14 chamber)
 - : held by the process piping

Process Connection: Screw-in, Flange, flow-through

Construction of Wetted Part:

- Sensor-holding base:
 - Stainless steel (316 SS) and Fluoro rubber when using screw-in type holder or the chamber made of stainless steel.
 - PP and Fluoro rubber when using the chamber made of PP.
- 0.01 cm⁻¹, 0.1 cm⁻¹ cell constant, two-electrode sensor:
 - Stainless steel (316 SS) and ethylene chloride trifluoride
- 10 cm⁻¹ cell constant, two-electrode sensor:
 - reinforced epoxy resin and graphite
- 10 cm⁻¹ cell constant, four-electrode sensor:
 - polyvinylidene difluoride (PVDF), glass and platinum
- Stem (flow-through type):
 - SCS14 or polypropylene resin

Weight:

- Screw-in type
 - approx. 0.9 kg (-R31) (excluding the cable)
- Flange type
 - approx. 2.8 kg (-R31) (excluding the cable)
- Flow-through type (SCS14 chamber)
 - approx. 3.1 kg (excluding the cable)
- Flow-through type (SCS14 chamber, flanged)
 - approx. 4.5 kg (excluding the cable)
- Flow-through type (polypropylene chamber)
 - approx. 2.7 kg (excluding the cable)
- Flow-through type (polypropylene chamber, flanged)
 - approx. 3.2 kg (excluding the cable)
- Cable
 - ; approx. 0.3 kg for 5.5 m length
 - ; approx. 0.5 kg for 10 m length
 - ; approx. 0.9 kg for 20 m length.

- **WU41: Dedicated cable for the SC8SG**

- Cable : Six multicore wire
- Diameter: 9.2 mm
- Material : Thermoplastic PVC

3. SC210G:

- Cable with pin terminals (applicable to FLXA202, FLXA21, FLXA402)
- Cable with M4 ring terminals (applicable to FLXA202, FLXA21)
- Cable with M3 ring terminals (applicable to FLXA402)

Object of measurement:

- Conductivity of solutions
- Measuring principle : Two-electrode system
- Cell constant : 0.05 cm⁻¹, 5 cm⁻¹
- Measuring range : 0-0.5 μ S/cm to 0-200 μ S/cm
 - (Cell constant: 0.05 cm⁻¹)
 - 0-200 μ S/cm to 0-20 mS/cm
 - (Cell constant: 5 cm⁻¹)
- Temperature Range: 0 to 105°C
 - (chamber material: SCS14)
 - 0 to 100°C
 - (chamber material: Polypropylene)
- Pressure range : 0 to 1 MPa
 - (chamber material: SCS14)
 - 0 to 500 kPa
 - (chamber material: Polypropylene)

Flow rate of Sample Solution:

No particular limitation applies, although a value of less than 20 L/min. is recommended for flow-through detectors.

Note: No limitation applies to flow rate (flow velocity) as far as measurement is concerned. However, when using flow-through detectors, electrodes or the inner walls of a liquid chamber may be worn out drastically at higher flow speeds if a measured solution contains slurry. Air bubbles should not be mixed in the sample solutions to obtain correct measured values.

Temperature sensor: Thermistor (PB36NTC)

Wet part Materials

- SC210G-A: For sensor, Stainless steel (316 SS), Fluoro rubber (FKM) (O-ring) and Polytrifluorochloroethylene For body, Stainless steel (316 SS), polypropylene and Fluoro rubber (FKM) (O-ring)
- SC210G-B: For sensor, Platinum, glass and Fluoro rubber (FKM) (O-ring) For body, Stainless steel (316 SS), polypropylene and Fluoro rubber (FKM) (O-ring)
- Flange (Flange type): Stainless steel (316 SS)
- Flow-through type holder: SCS14 or polypropylene resin, Fluororubber(FKM) (O-ring)
- Gate valve: SCS13A, Stainless steel (304 SS), Stainless steel (316 SS Hard chrome plating), Expanded graphite, PTFE

Construction: JIS C0920 watertight (equal to NEMA 4)

Weight:

- Screw-in type
 - approx. 2.1 kg (-L015) (excluding the cable)
- Flange type
 - approx. 4.3 kg (-L015) (excluding the cable)
- Flow-through type (SCS14 chamber)
 - approx. 3.7 kg (excluding the cable)
- Flow-through type (SCS14 chamber, flanged)
 - approx. 5.0 kg (excluding the cable)
- Flow-through type (polypropylene chamber)
 - approx. 3.1 kg (excluding the cable)
- Flow-through type (polypropylene chamber, flanged)
 - approx. 3.3 kg (excluding the cable)
- With gate valve
 - approx. 3.9 kg (excluding the cable)
- Cable
 - ; approx. 0.9 kg for 3 m length
 - ; approx. 1.5 kg for 5 m length
 - ; approx. 3.0 kg for 10 m length
 - ; approx. 1.5 kg for 15 m length
 - ; approx. 6.0 kg for 20 m length.

■ Compliance with the simple apparatus requirements

SC210G and SC4AJ meet the simple apparatus requirements defined in the following standards.

Note: TIS certified types cannot be connected.

Use the sensors under the conditions of use required by the standards.

Applicable standards:

- ANSI/ISA-60079-11 (2014)
- ANSI/ISA-60079-0 (2009)
- CAN/CSA-C22.2 NO. 60079-11:14
- CAN/CSA-C22.2 NO. 60079-0:11

방호장치 의무안전인증 고시
GB 3836.4-2010

Conditions of use:

(1) Use in combination with an internally isolated analyzer, or use with, an analyzer in combination with isolated barrier.

The FLXA202/FLXA21 is internally isolated.

(2) Upper limit of the process temperature.

The upper limit of process temperature is indicated below when the sensor is used in combination with a YOKOGAWA analyzer.

For FLXA202/FLXA21, model and suffix code below is available.

FLXA21-D-□-D-◇-C1-○-A-N-LA-N-NN

□: can be any value.

◇: must be EA, CD, CH, or EG.

○: must be NN or C1.

Any option code is available.

FLXA202-D-□-D-◇-C1-○-A-N-LA-N-NN

□: can be any value.

◇: must be CD, CH, or CG.

○: must be NN or C1.

Any option code is available.

Upper limit of process temperature on the SC210G

Analyzer used in combination Ambient temperature Ta Temperature class	FLXA202/FLXA21	
	40°C	60°C
T6	30	30
T5	95 (*1)	35
T4	105	45
T3	105	65
T2	105	105
T1	105	105

*1: Care about upper limit 100°C of temperature class T5 should be taken.

Upper limit of process temperature on the SC4AJ

Analyzer used in combination Ambient temperature Ta Temperature class	FLXA202/FLXA21	
	40°C	60°C
T6	49	49
T5	95 (*1)	64
T4	110	99
T3	110	110
T2	110	110
T1	110	110

*1: Care about upper limit 100°C of temperature class T5 should be taken.

Other warnings are provided in the user's manual.

■ Applicable analyzer with various detectors

Detector Type of terminals	SC4AJ			SC8SG			SC210G		
	Pin	Ring M4	Ring M3	Pin	Ring M4	Ring M3	Pin	Ring M4	Ring M3
Analyzer: FLXA402 (*)	Yes	N.A.	Yes	Yes	N.A.	Yes	Yes	N.A.	Yes
Analyzer: FLXA202 (*), FLXA21	Yes	Yes	N.A.	Yes	Yes	N.A.	Yes	Yes	N.A.

*: FLXA402 or FLXA202 when connected to a SA11 can be connected with sensors equipped with Variopin connector.
(SC4A...-VS, SC42-□V, SX42...□V, SC4AJ...-VS, SC8SG...-VS)

■ MODEL AND SUFFIX CODES

1. SC4AJ

Model	Suffix Code	Option Code	Description
SC4AJ	Conductivity sensor
Material	-T -S	Titanium (Only for -AD) 316L SS
Fitting type	-AD -SA -SB -SC	Adapter mounting type Welding socket type (*1) 1 or 1.5 inch welding clamp type (*2) 2 inch welding clamp type (*2)
Sensor length	-09 -15 -NN	9 cm (Code for -AD) 15 cm (Code for -AD) fixed length (Code for -SA, -SB, -SC)
Cell constant	-002 -010	0.02 cm ⁻¹ 0.1 cm ⁻¹
Cable length	-03 -05 -10 -15 -20 -X1 -X2 -X3 -X4 -X5 -Y1 -Y2 -Y3 -Y4 -Y5 -VS	3 m (pin terminals) 5 m (pin terminals) 10 m (pin terminals) 15 m (pin terminals) 20 m (pin terminals) 3 m (M4 ring terminals) (*4) 5 m (M4 ring terminals) (*4) 10 m (M4 ring terminals) (*4) 15 m (M4 ring terminals) (*4) 20 m (M4 ring terminals) (*4) 3 m (M3 ring terminals) (*4) 5 m (M3 ring terminals) (*4) 10 m (M3 ring terminals) (*4) 15 m (M3 ring terminals) (*4) 20 m (M3 ring terminals) (*4) Variopin connector (*6)
Temperature sensor	-T1	Pt1000
Option	For AD only For SA only For SB only For SC only Oil prohibit	/PS /PF /RS /RF /SA1 /SA2 /SB1 /SB2 /SC1 /DG1	3/4NPT adapter 316 SS 3/4NPT adapter PVDF R3/4 adapter 316 SS R3/4 adapter PVDF Straight welding socket 316L SS Angled welding socket 15° 316L SS Welding clamp 1 inch 316L SS Welding clamp 1.5 inch 316L SS Welding clamp 2 inch 316L SS Oil-prohibited use (*3)

- *1: When you select Fitting type -SA, place an order on the SC4AJ with Option code /SA1 or /SA2.
 *2: When you select Fitting type -SB, place an order on the SC4AJ with Option code /SB1 or /SB2 (including seal ring),
 When you select Fitting type -SC, place an order on the SC4AJ with Option code /SC1 (including seal ring).
 *3: Washing treatment of wet part with alcohol.
 *4: Used for connection to FLXA202, FLXA21.
 *5: Used for connection to FLXA402, SC450G.
 *6: Used for connection with SA11. Sensor length -09 is not selectable.

Spare parts for SC4AJ

Parts No.	Description
K9670MA	O-ring for -SA (excluding -VS)
K9675VY	O-ring set for -SA (for -VS)
K9670MK	Seal rings for /SB1 or /SB2
K9670MP	Seal rings for /SC1
K9670MT	3/4 NPT Stainless steel adapter for -AD
K9670MU	3/4 NPT PVDF Adapter for -AD
K9670MV	R3/4 Stainless steel adapter for -AD
K9670MW	R3/4 PVDF Adapter for -AD
K9670MD	Angled welding socket and mounting nut for -SA
K9670ME	Straight welding socket for -SA
K9670MB	Angled welding socket for -SA
K9670MC	Straight welding socket for -SA
K9670ML	Welding clamp 1 or 1.5 inch for -SB
K9670MQ	Welding clamp 2 inch for -SC

2. SC8SG

Model	Suffix Code	Option Code	Description	
SC8SG	Conductivity detector	
Measuring range	-R31 -R42 -R61	Low range; cell constant: 0.01 cm ⁻¹ Medium range; cell constant: 0.1 cm ⁻¹ High range; cell constant: 10 cm ⁻¹	
Electrode configuration	-T -F	2-electrode system (for both 0.01 cm ⁻¹ , 0.1 cm ⁻¹ , 10cm ⁻¹ cell constants) - for general measurements 4-electrode system (for 10 cm ⁻¹ cell constant only) - for countermeasures against polarization due to contamination (*1)	
Construction	Screw-in type	-100	with welding socket (*2)
		-101	without welding socket (a welding socket [K9208BK] should be ordered separately)
	Flange type	-102	R1-1/2 material: SCS14
		-206	JIS 10 K 50 RF Flange
		-207	ANSI Class 150 2 RF flange (with serration)
	Flow-through type (*3)	-208	JPI Class 150 2 RF flange
		-302	Rc1/2 female threaded; chamber material: SCS14
		-312	Rc1/2 female threaded; chamber material: PP
		-303	1/2NPT female threaded; chamber material: SCS14
		-313	1/2NPT female threaded; chamber material: PP
		-304	JIS 10K 15 RF flange; chamber material: SCS14
-314		JIS 10K 15 FF flange; chamber material: PP	
-305	ANSI Class150 1/2 RF flange with serration; chamber material: SCS14		
-315	ANSI Class150 1/2 FF flange; chamber material: PP		
Cable length	-P1 -P2 -P3	5.5 m (special cable supplied with detector) (pin terminals)	
		10 m (special cable supplied with detector) (pin terminals)	
		20 m (special cable supplied with detector) (pin terminals)	
	-F1 -F2 -F3	5.5 m (special cable supplied with detector) (fork terminal)	
		10 m (special cable supplied with detector) (fork terminal)	
		20 m (special cable supplied with detector) (fork terminal)	
	-X1 -X2 -X3	5.5 m (special cable supplied with detector) (M4 ring terminal) (*4)	
		10 m (special cable supplied with detector) (M4 ring terminal) (*4)	
		20 m (special cable supplied with detector) (M4 ring terminal) (*4)	
	-Y1 -Y2 -Y3	5.5 m (special cable supplied with detector) (M3 ring terminal) (*5)	
		10 m (special cable supplied with detector) (M3 ring terminal) (*5)	
		20 m (special cable supplied with detector) (M3 ring terminal) (*5)	
	-VS	Variopin connector (*6)	
Style code	*A	Style A	
Option		/PS /SS	Stainless Steel Mounting hardware (for PP chamber) Stainless Steel Mounting hardware (for SCS14 chamber)	

*1: Electrode configuration -F cannot be selected when -R31 or -R42 is selected.

When -R61 is selected, 2-electrode system -T is normally used, however, for process where detectors are susceptible to contamination, a 4-electrode system -F should be used.

*2: If a welding socket (K9208BK) needs to be ordered beforehand, either place a separate order or prepare one by referring to the external view later in this brochure.

*3: No chamber is equipped with a mounting hardware. Please place an order on the SC8SG with option code /PS or /SS when you select flow-through model.

The PP chamber can have cracks or splits unless it is supported by a mounting hardware.

*4: Used for connection to FLXA202, FLXA21.

*5: Used for connection to FLXA402, SC450G.

*6: Used for connection with SA11. SC8SG-R61-T (Measuring range: -R61 with Electrode configuration -T) is not selectable.

Spare Parts for SC8SG

Parts No.	Description
K9208BA	0.01 cm ⁻¹ cell constant, two-electrode sensor
K9208BB	0.1 cm ⁻¹ cell constant, two-electrode sensor
K9208BC	10 cm ⁻¹ cell constant, two-electrode sensor
K9208BD	10 cm ⁻¹ cell constant, four-electrode sensor
K9208BV	0.01 cm ⁻¹ cell constant, two-electrode sensor, Variopin connector
K9208BY	0.1 cm ⁻¹ cell constant, two-electrode sensor, Variopin connector
K9208BZ	10 cm ⁻¹ cell constant, four-electrode sensor, Variopin connecto
K9208BK	Welding socket for screw-in model
G9303EB	O-ring

WU41

This cable can be purchased additionally. SC8SG is supplied with cables of selected length.

Model	Suffix code	Option code	Description
WU41	Dedicated Cable for SC8SG
Cable end	-F	fork terminals
	-P	pin terminals
	-X	M4 ring terminals (*1)
	-Y	M3 ring terminals (*2)
Cable length	-05	5.5 m
	-10	10 m
	-20	20 m

*1: Used for connection to FLXA202, FLXA21.

*2: Used for connection to FLXA402, SC450G

3. SC210G

Model	Suffix Code	Option Code	Description
SC210G	Conductivity detector
Measuring range	-A	Low range; cell constant: 0.05 cm ⁻¹
	-B	Medium range; cell constant: 5 cm ⁻¹
Construction	Screw-in type	-100	R1-1/2 male
		-103	1-1/2NPT male
	Flange type	-206	JIS 10K 50 RF flange
		-207	ANSI Class150 2 RF flange (with serration)
		-208	JPI Class150 2 RF flange
	Flow-through type (*1)	-302	Rc1/2 female, chamber material: SCS14
		-312	Rc1/2 female, chamber material: PP
		-303	1/2NPT female, chamber material: SCS14
		-313	1/2NPT female, chamber material: PP
		-304	JIS 10K 15 RF flange, chamber material: SCS14
		-314	JIS 10K 15 FF flange, chamber material: PP
		-305	ANSI Class150 1/2 RF flange with serration, chamber material: SCS14
	With gate valve	-315	ANSI Class150 1/2 FF flange, chamber material: PP
-306		JPI Class150 1/2 RF flange, chamber material: SCS14	
-402		R1-1/4 male	
-403		1-1/4NPT male	
Sensor length	-L015	150 mm (Standard)
	-L030	300 mm (*2)
	-L050	500 mm (*2)
	-L100	1000 mm (*2)
	-L150	1500 mm (*2)
	-L200	2000 mm (*2)
Cable length	-03	3 m (M4 ring terminals) (*3)
	-05	5 m (M4 ring terminals) (*3)
	-10	10 m (M4 ring terminals) (*3)
	-15	15 m (M4 ring terminals) (*3)
	-20	20 m (M4 ring terminals) (*3)
	-AA	3 m (pin terminals)
	-BB	5 m (pin terminals)
	-CC	10 m (pin terminals)
	-DD	15 m (pin terminals)
	-EE	20 m (pin terminals)
	-Y1	3 m (M3 ring terminals) (*4)
	-Y2	5 m (M3 ring terminals) (*4)
	-Y3	10 m (M3 ring terminals) (*4)
	-Y4	15 m (M3 ring terminals) (*4)
	-Y5	20 m (M3 ring terminals) (*4)
Style code	*A	Style A
Option	/SCT	Stainless steel tag plate
	/ANSI	With ANSI connection adaptor (*5)
	/PF	DAI-ELperflow (perfluoro-elastomer) specification (*6)
	/PS	SUS mounting hardware (for PP construction)
	/SS	SUS mounting hardware (for SCS14 construction)
	/X1	Epoxy-coated (baked)
	/DG1	Oil-prohibited use (Degrease cleaning treatment) (except for the type with gate valve)
	/MCT	Material Certificate (*7) (except for gate valve)

*1: The model is not equipped with a mounting brackets, place an order on the SC210G with option code /PS or /SS when you select flow-through model. The PP chamber material can have cracks or splits unless it is not supported by a mounting hardware.

*2: Only for Screw-in type and Flange type

- *3: Used for connection to FLXA202, FLXA21.
 *4: Used for connection to FLXA402, SC450G.
 *5: Adaptor for cable inlet (carbon steel)
 *6: Materials for O-ring of electrode assembly and chamber seal become perfluoro-elastomer. But, in construction -402 and -403, the sealing part of gate valve doesn't become the elastomer.
 *7: Additional lead time is required.

Spare Parts for SC210G

Name	Part No.	Remarks
Electrode Assembly (*1) (for SC210G-A)	K9208EA K9208EB K9208EC K9208ED K9208EE K9208EF K9315NA K9315NB K9315NC K9315ND K9315NE K9315NF	150 mm (C=0.05cm ⁻¹) 500 mm (C=0.05cm ⁻¹) 1000 mm (C=0.05cm ⁻¹) 1500 mm (C=0.05cm ⁻¹) 2000 mm (C=0.05cm ⁻¹) 300 mm (C=0.05cm ⁻¹) 150 mm (C=0.05cm ⁻¹) with perfluoro-elastomer 300 mm (C=0.05cm ⁻¹) with perfluoro-elastomer 500 mm (C=0.05cm ⁻¹) with perfluoro-elastomer 1000 mm (C=0.05cm ⁻¹) with perfluoro-elastomer 1500 mm (C=0.05cm ⁻¹) with perfluoro-elastomer 2000 mm (C=0.05cm ⁻¹) with perfluoro-elastomer
Electrode Assembly (*2) (for SC210G-A with gate valve)	K9208KA K9315NN	(C=0.05cm ⁻¹) (C=0.05cm ⁻¹) with perfluoro-elastomer
Electrode Assembly (*1) (for SC210G-B)	K9208JH K9208JF K9208JB K9208JC K9208JD K9208JE K9208JJ K9315NH K9315NJ K9315NK K9315NL K9315NM	150 mm (C=5cm ⁻¹) 300 mm (C=5cm ⁻¹) 500 mm (C=5cm ⁻¹) 1000 mm (C=5cm ⁻¹) 1500 mm (C=5cm ⁻¹) 2000 mm (C=5cm ⁻¹) 150 mm (C=5cm ⁻¹) with perfluoro-elastomer 300 mm (C=5cm ⁻¹) with perfluoro-elastomer 500 mm (C=5cm ⁻¹) with perfluoro-elastomer 1000 mm (C=5cm ⁻¹) with perfluoro-elastomer 1500 mm (C=5cm ⁻¹) with perfluoro-elastomer 2000 mm (C=5cm ⁻¹) with perfluoro-elastomer
Electrode Assembly (*2) (for SC210G-B with gate valve)	K9208MA K9315NP	(C=5cm ⁻¹) (C=5cm ⁻¹) with perfluoro-elastomer
Cable	K9315QA K9315QB K9315QC K9315QF K9315QG K9315QR K9315QS K9315QT K9315QU K9315QV K9315QJ K9315QK K9315QL K9315QM K9315QQ	3 m (M4 ring terminals, SC210G...-03) 5 m (M4 ring terminals, SC210G...-05) 10 m (M4 ring terminals, SC210G...-10) 15 m (M4 ring terminals, SC210G...-15) 20 m (M4 ring terminals, SC210G...-20) 3 m (pin terminals) 5 m (pin terminals) 10 m (pin terminals) 15 m (pin terminals) 20 m (pin terminals) 3 m (M3 ring terminals) 5 m (M3 ring terminals) 10 m (M3 ring terminals) 15 m (M3 ring terminals) 20 m (M3 ring terminals)
O-ring	K9050AT K9050MR K9319RN	Fluoro-rubber (FKM) O-ring (for screw-in type, flange type and flow-through type) Fluoro-rubber (FKM) O-ring (for gate valve type) Perfluoro-elastomer O-ring (for all types)

- *1: For the electrode assembly for oil-prohibited use (/DG1) and/or with material certificate (/MCT), please contact Yokogawa.
 *2: For the electrode assembly with material certificate (/MCT), please contact Yokogawa.

DIMENSIONS

1. SC4AJ

<Adapter mounting type>

SC4AJ-□-AD-09

Sensor length: 09 (9 cm)

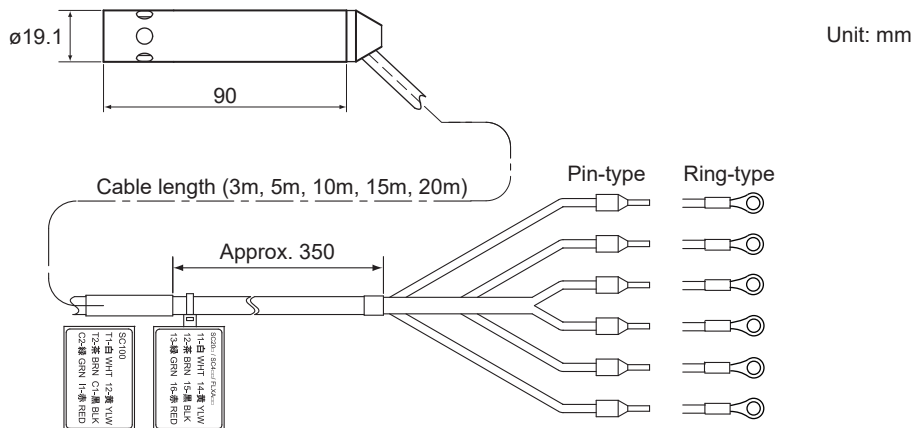

SC4AJ-□-AD-15

Sensor length: 15 (15 cm)

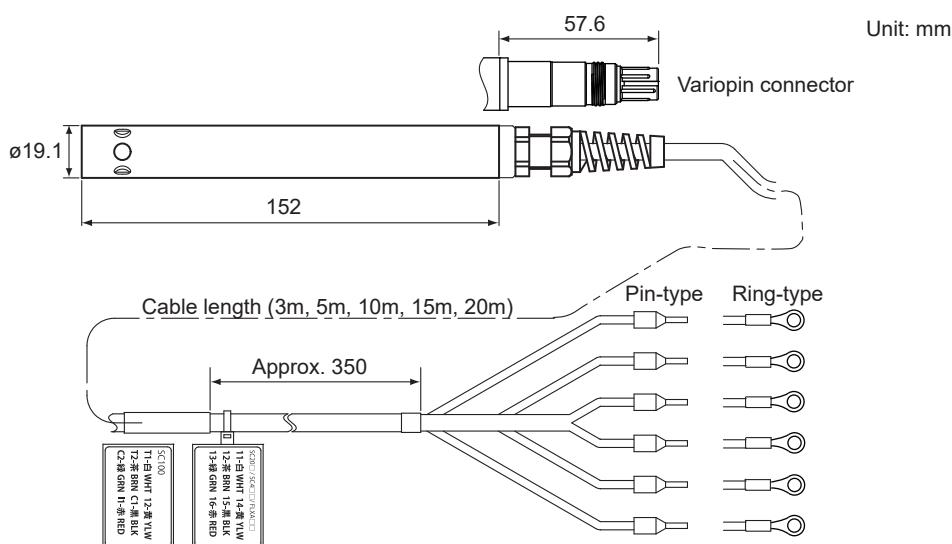

● Option: Adapter mounting type (-AD)

/PS (Stainless Steel)

/RS (Stainless Steel)

/PF (PVDF)

/RF (PVDF)

Unit: mm

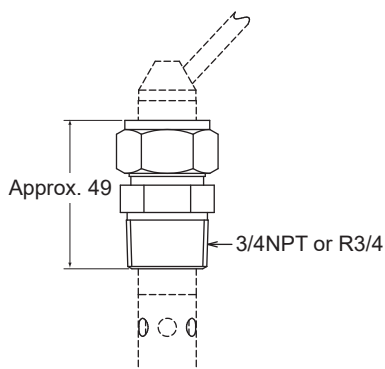

**<Welding socket type>
SC4AJ-□-SA-NN**

Unit: mm

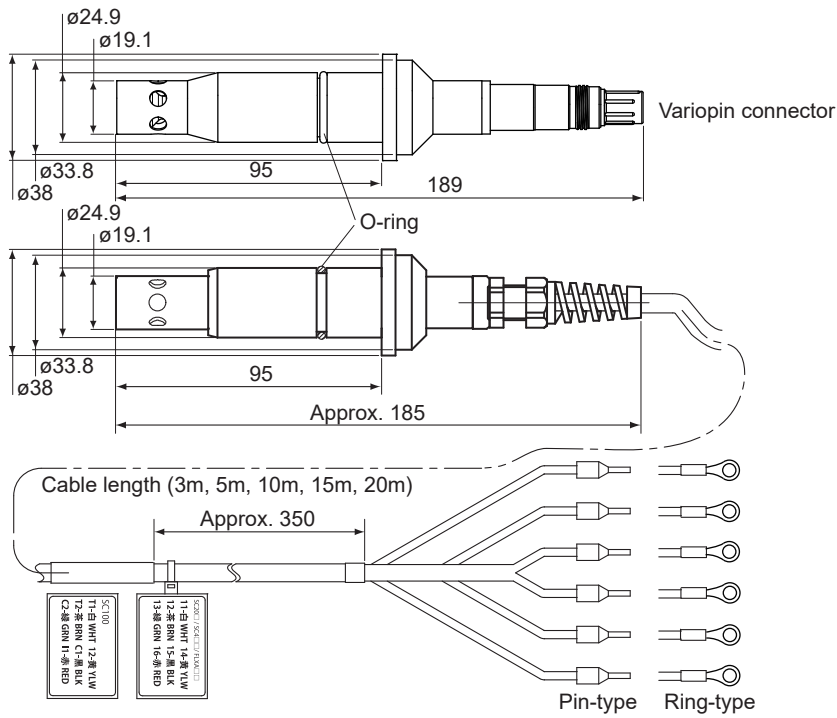

● Option: Welding socket type (-SA)

Straight welding socket: /SA1

Angled welding socket: /SA2

Unit: mm

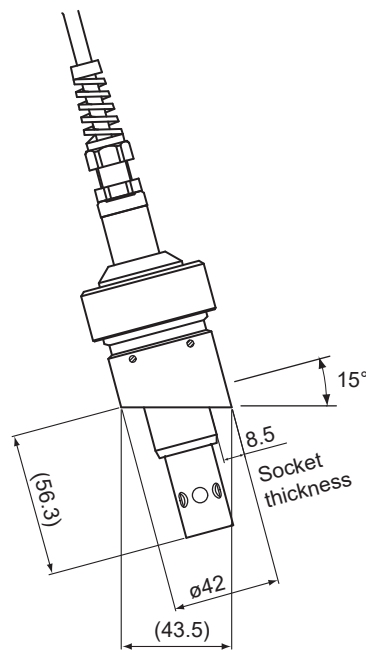
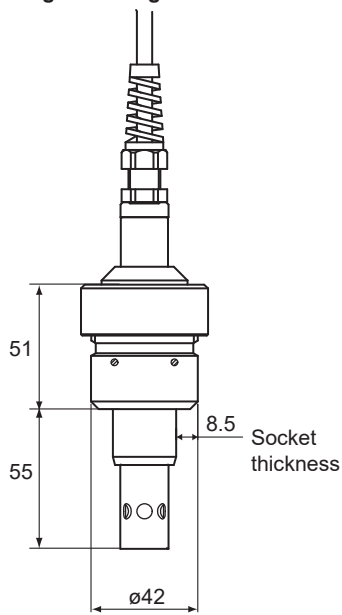

<Welding clamp type>
SC4AJ-□-SB-NN

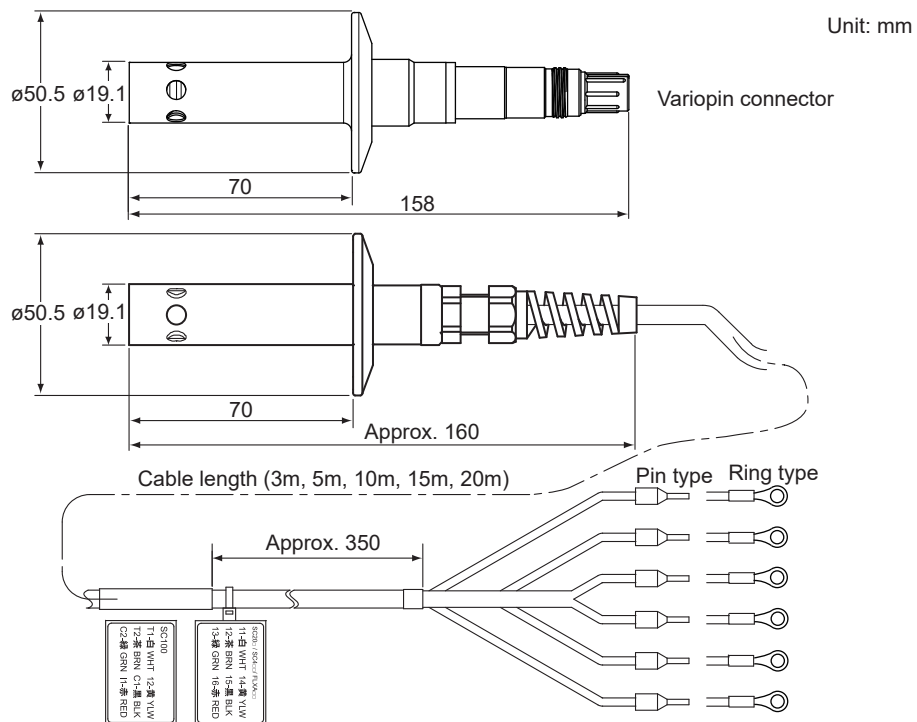

● Option: Welding clamp type (-SB)

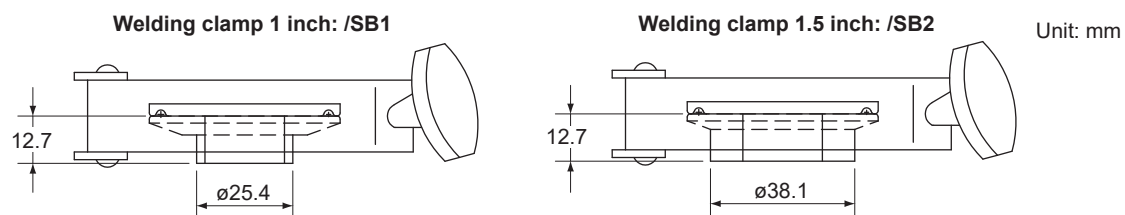

Sensor SC4AJ-□-SC-NN

Unit: mm

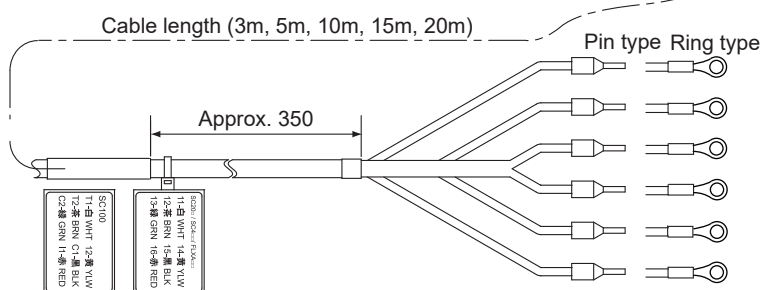
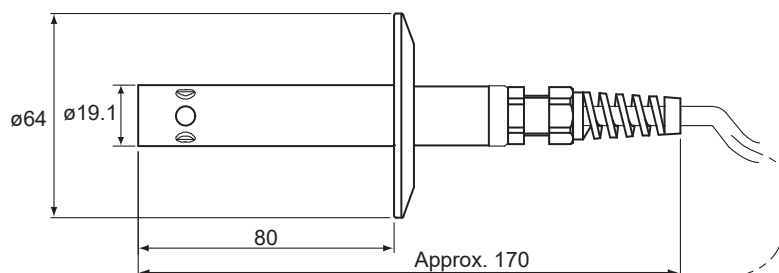
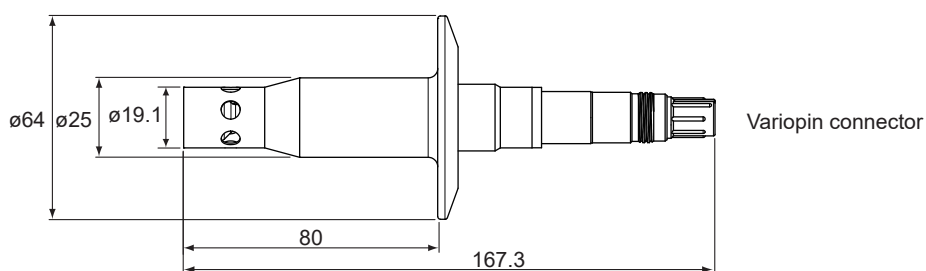

● Option: Welding clamp type (-SC)

Welding clamp 2 inch: /SC1

Unit: mm

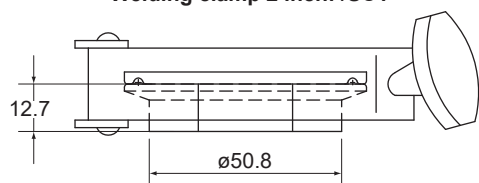

2. SC8SG

<Screw-in type> Only the difference between SC8SG-R□□-□-100 and SC8SG-R□□-□-101 is whether or not having a welding socket. SC8SG-R□□-□-100 has a welding socket but SC8SG-R□□-□-101 does not.

SC8SG-R31-T-100 (Low range)
Electrode with 0.01cm⁻¹ Cell constant
Two-electrode system

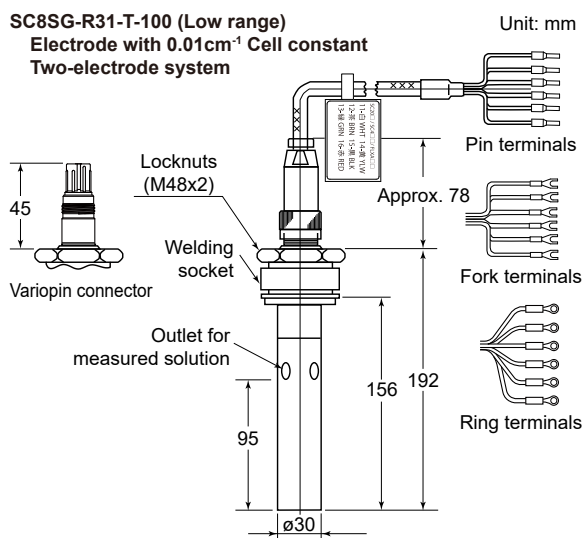

SC8SG-R61-F-100 (High range)
Electrode with 10cm⁻¹ Cell constant
Four-electrode system

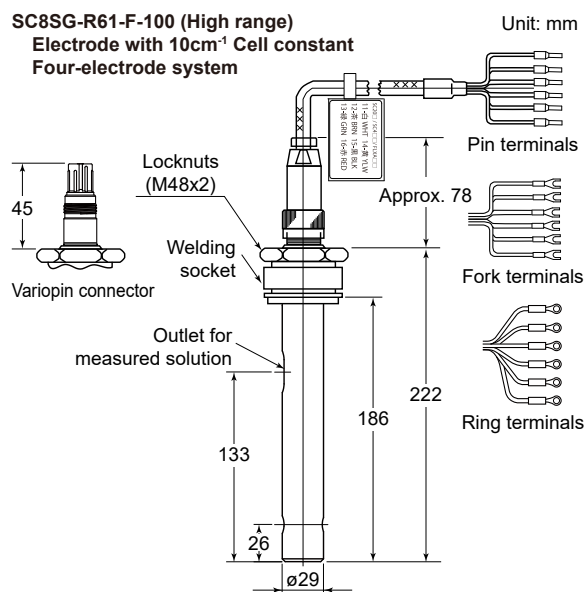

SC8SG-R42-T-100 (Medium range)
Electrode with 0.1cm⁻¹ Cell constant
Two-electrode system

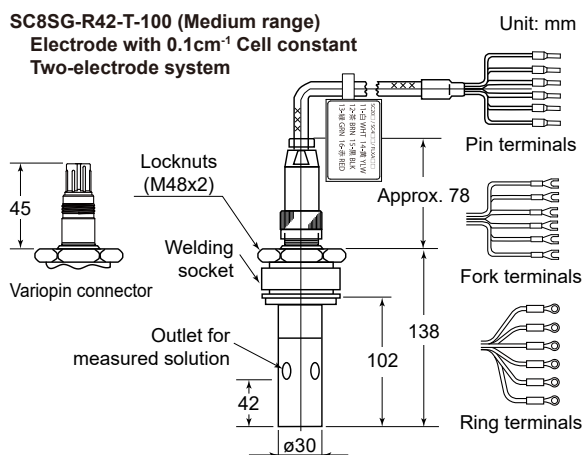

Welding socket
Parts No: K9208BK (Material: 316SS)

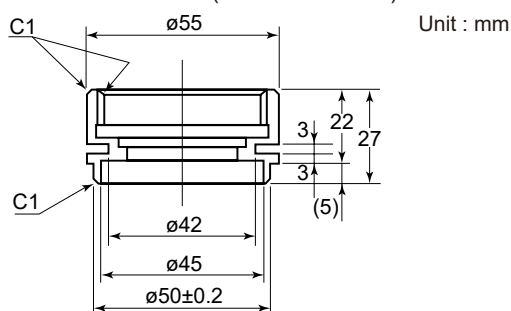

Note: If you make the welding socket for screw-in type, refer to the above drawing.

SC8SG-R61-T-100 (High range)
Electrode with 10cm⁻¹ Cell constant
Two-electrode system

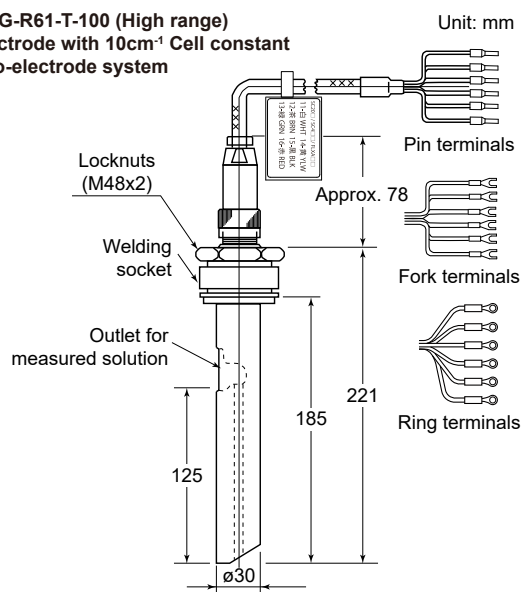

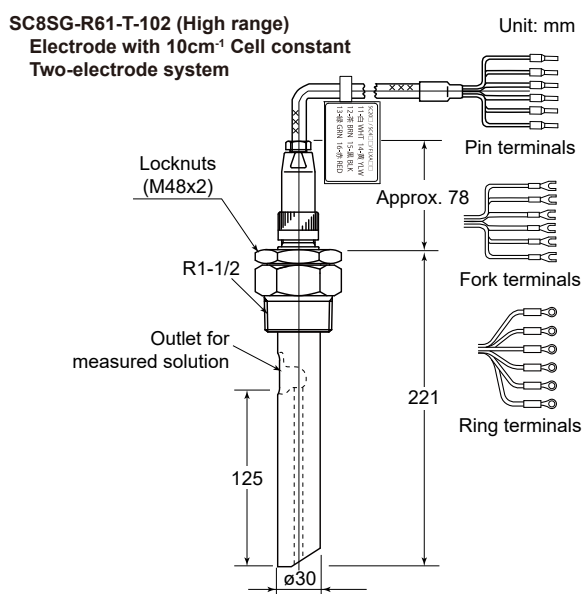
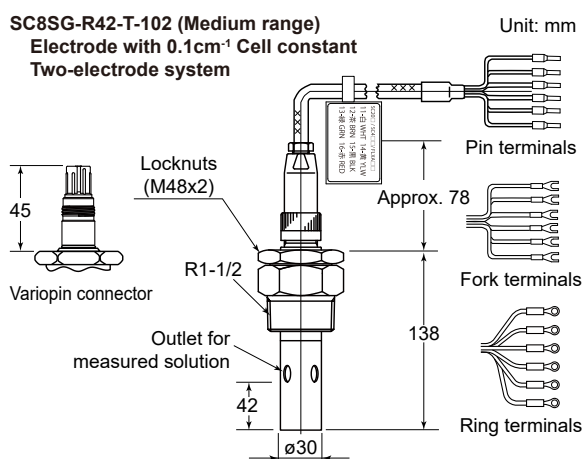
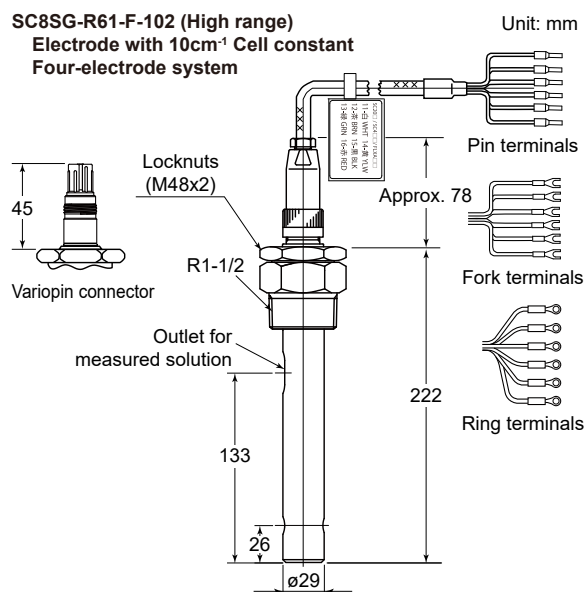
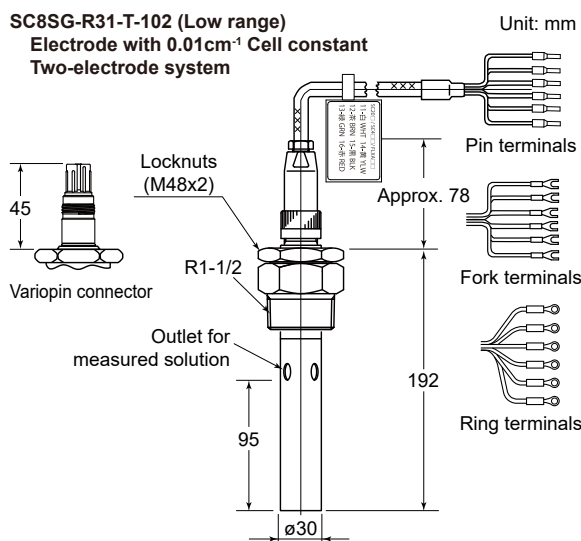

<Flange type>

SC8SG-R□□-□-20□

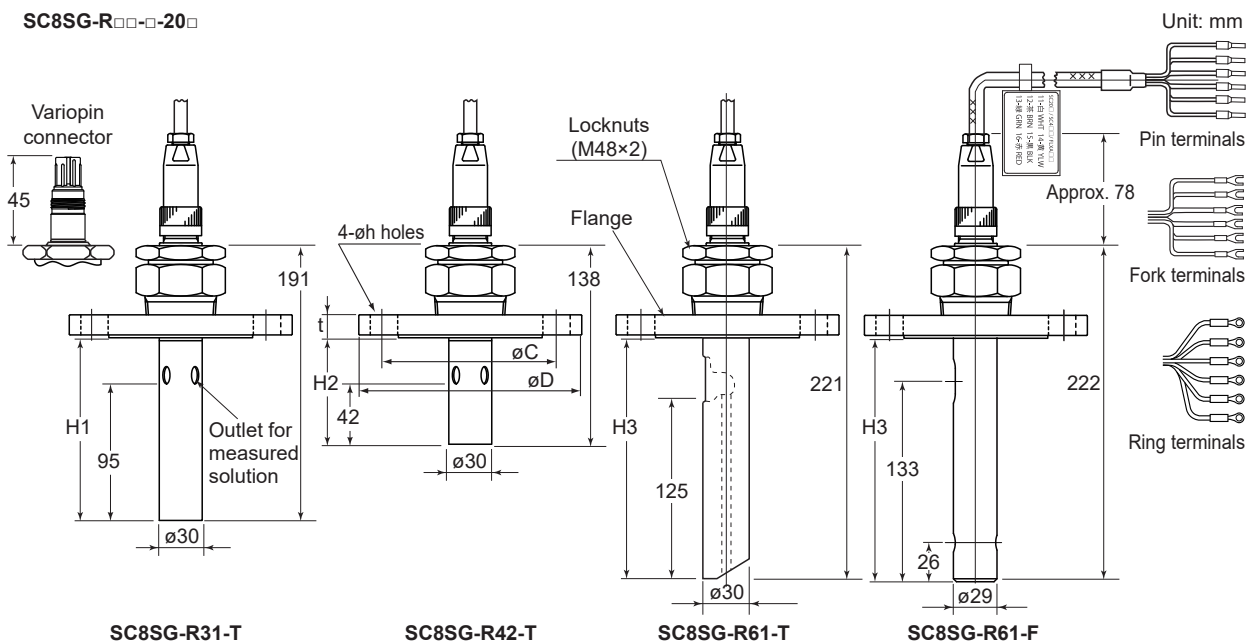

SC8SG-R31-T

SC8SG-R42-T

SC8SG-R61-T

SC8SG-R61-F

<Flange>

<Insertion length>

Model and Code	Flange rating	øC	øD	t	øh	H1	H2	H3
SC8SG - R□□ - □ - 206 - □□ *A	JIS 10K 50 RF	120	155	16	19	127	74	157
SC8SG - R□□ - □ - 207 - □□ *A	ANSI Class150 2 RF	120.7	152.4	19.1	19.1	124	71	154
SC8SG - R□□ - □ - 208 - □□ *A	JPI Class150 2 RF	120.6	152	19.5	20	123.5	70.5	153.5

Note: ANSI flange with serrations

<Flow-through type>
SC8SG-R□□-□-302,
SC8SG-R□□-□-303,
Screw connection (Chamber Material: SCS14)

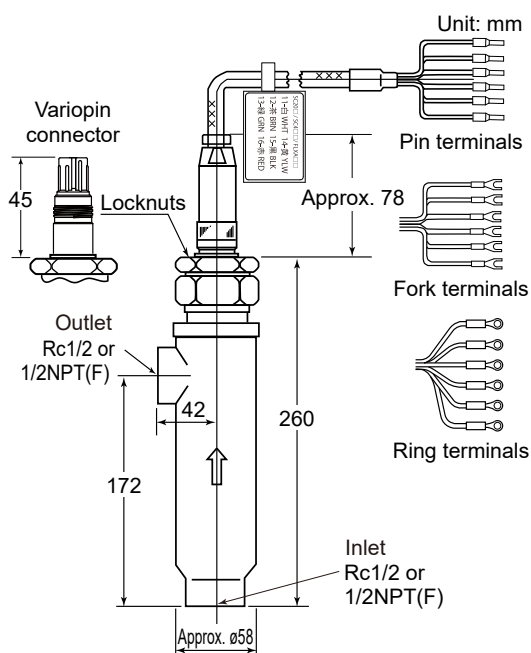

● Option: Mounting hardware (-SS)

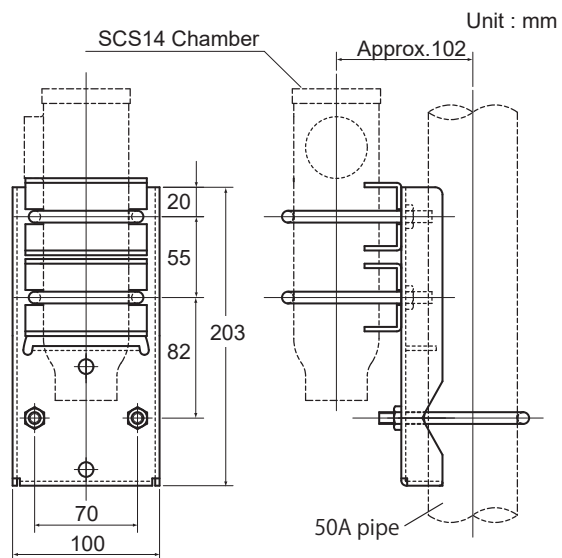

SC8SG-R□□-□-304,
SC8SG-R□□-□-305,
Flange connection (Chamber Material: SCS14)

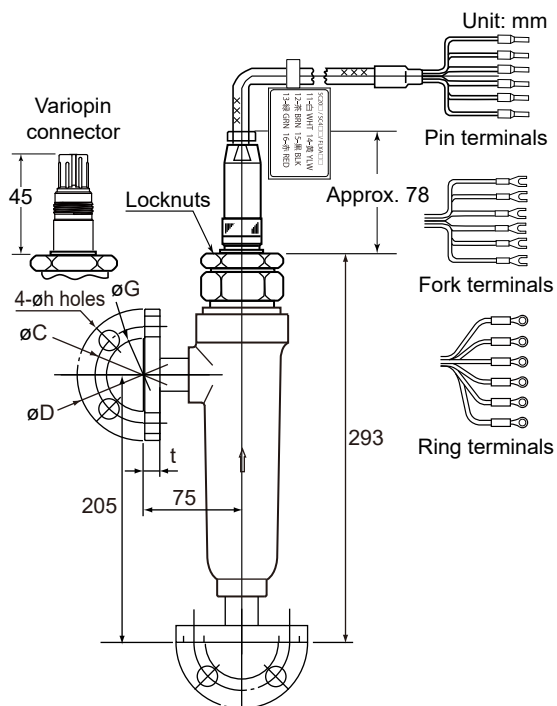

Flange rating	øC	øD	øG	øh	t
JIS 10K 15 RF	70	95	52	15	12
ANSI Class150 1/2 RF (with serration)	60.5	88.9	34.9	15.7	11.2

**SC8SG-R□□-□-312, SC8SG-R□□-□-313,
Screw connection (Chamber Material: PP) + Option (Mounting hardware (/PS))**

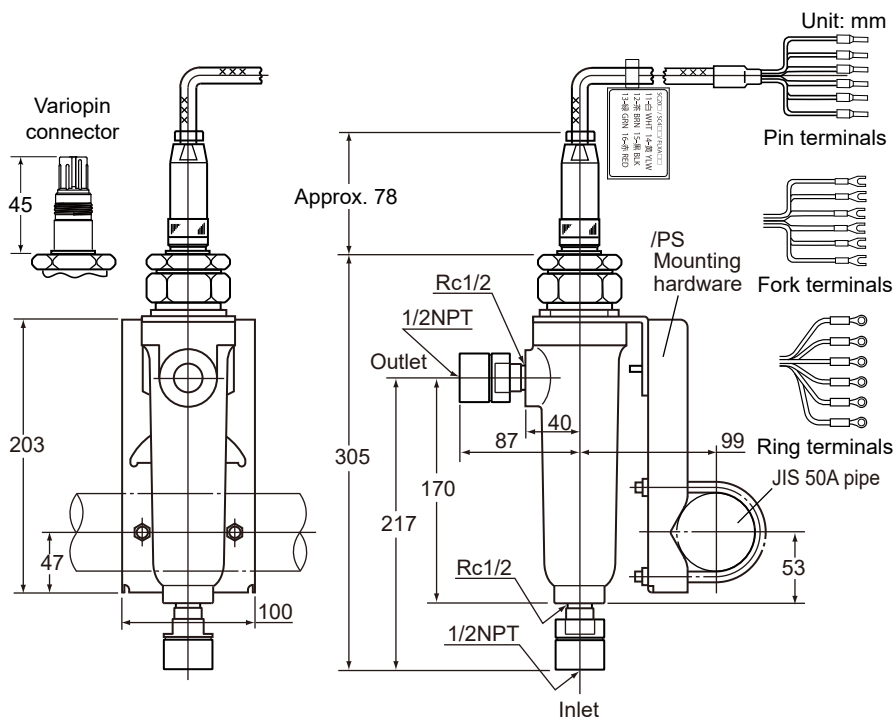

**SC8SG-R□□-□-314, SC8SG-R□□-□-315,
Flange connection (Chamber Material: PP) + Option (Mounting hardware (/PS))**

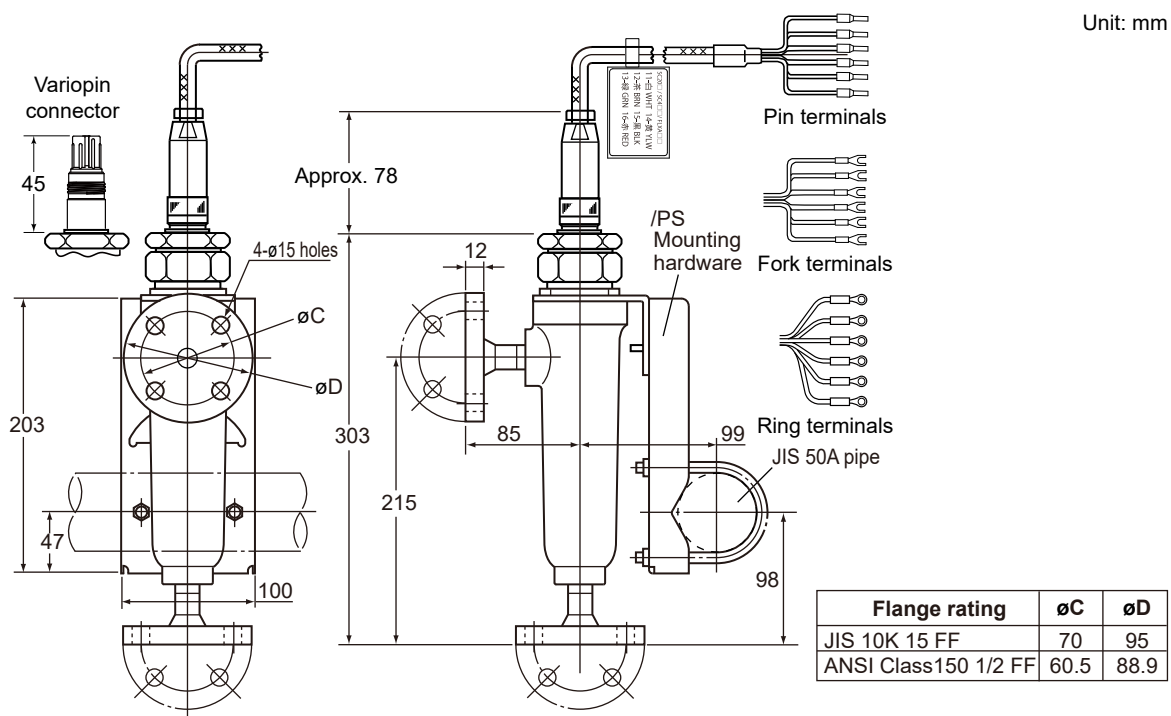

• WU41 for SC8SG

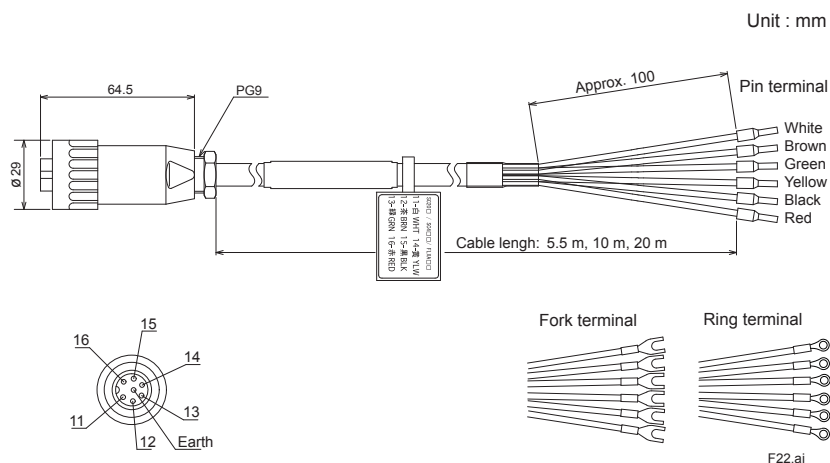

3. SC210G

• SC210G Detector - converter connection cable (accessory)

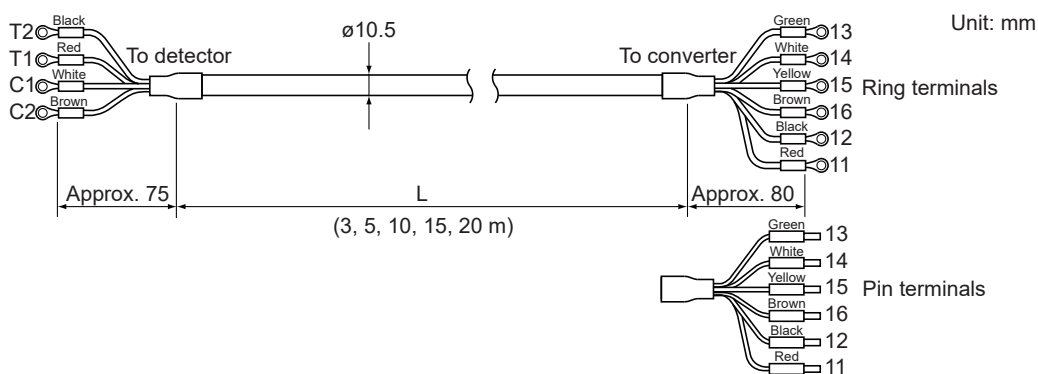

• Option: With ANSI connection adaptor (/ANSI)

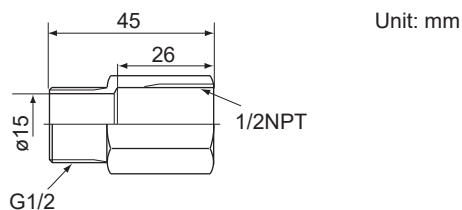

<Screw-in type>
SC210G-□-100, SC210G-□-103

Unit : mm

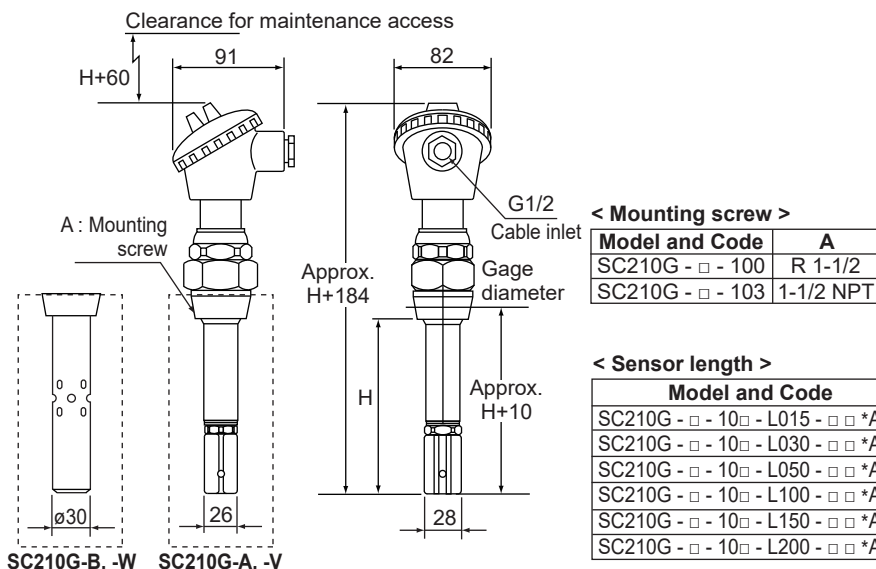

<Flange Type>
SC210G-□-206, SC210G-□-207, SC210G-□-208

Unit: mm

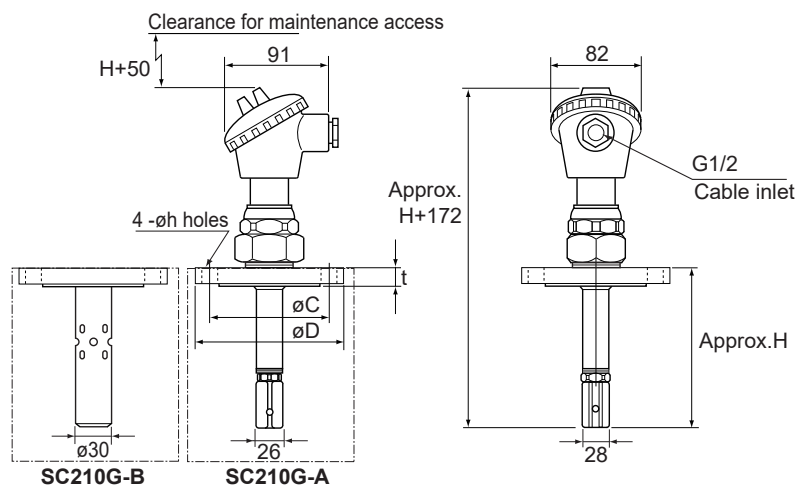

<Flange>

Model and code	Flange rating	øC	øD	t	øh
SC210G - □ - 206 - L □□□ - □□ *A	JIS 10K 50 RF	120	155	16	19
SC210G - □ - 207 - L □□□ - □□ *A	ANSI Class150 2 RF	120.7	152.4	19.1	19.1
SC210G - □ - 208 - L □□□ - □□ *A	JPI Class150 2 RF	120.6	152	19.5	20

Note : ANSI flange with serrations.

<Sensor length>

Model and code	H
SC210G - □ - 20□ - L015 - □□ *A	162
SC210G - □ - 20□ - L030 - □□ *A	312
SC210G - □ - 20□ - L050 - □□ *A	512
SC210G - □ - 20□ - L100 - □□ *A	1012
SC210G - □ - 20□ - L150 - □□ *A	1512
SC210G - □ - 20□ - L200 - □□ *A	2012

<Flow-through type>
SC210G-□-302, SC210G-□-303 *1
Screw connection (Chamber Material: SCS14)

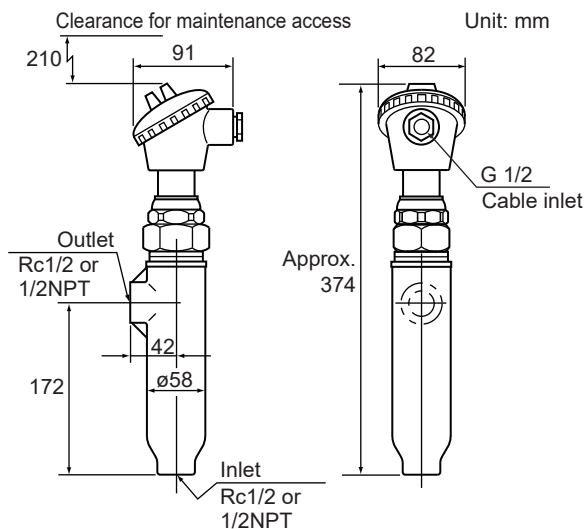

*1: Refer to p17 for Dimension and Fitting of Option (Mounting hardware (/SS)).

SC210G-□-312, SC210G-□-313
Screw connection (Chamber Material: PP)

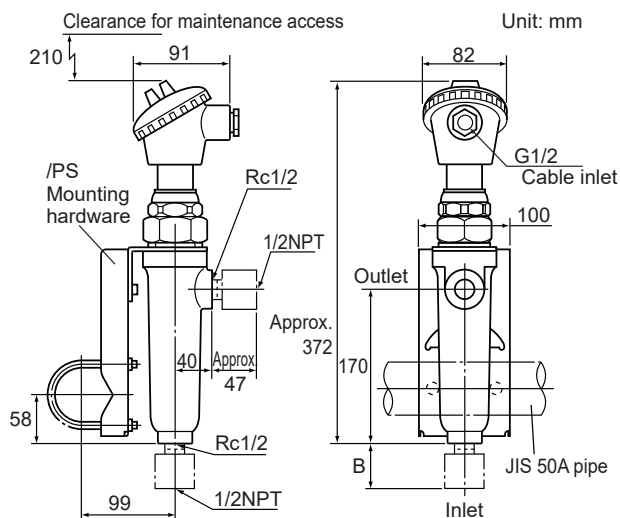

SC210G-□-304, SC210G-□-305
SC210G-□-306 *1
Flange connection (Chamber Material: SCS14)

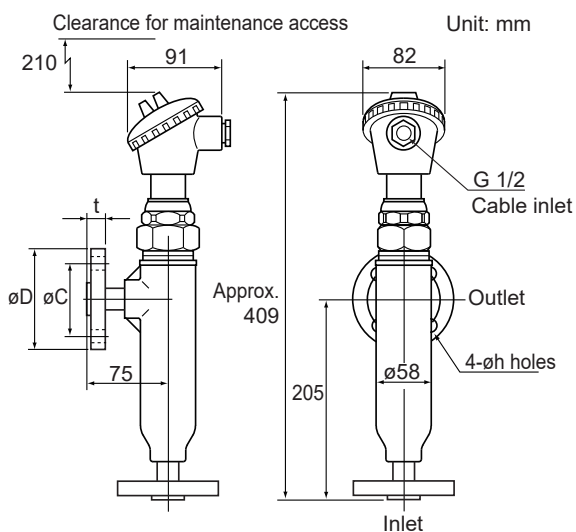

Flange rating	∅C	∅D	t	∅h
JIS 10K 15 RF	70	95	12	15
ANSI Class150 1/2 RF	60.5	88.9	11.2	15.7
JPI Class150 1/2 RF	60.3	89	10.9	16

Note: ANSI flange is serration.

*1: Refer to p17 for Dimension and Fitting of Option (Mounting hardware (/SS)).

SC210G-□-314, SC210G-□-315
Flange connection (Chamber Material: PP)

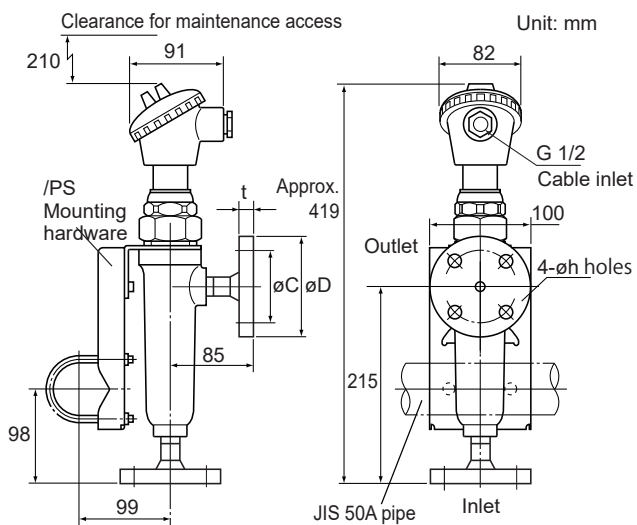

Flange rating	∅C	∅D	t	∅h
JIS 10K 15 FF	70	95	12	15
ANSI Class150 1/2 FF	60.5	88.9	12	15

<With gate valve>
SC210G-□-402, SC210G-□-403

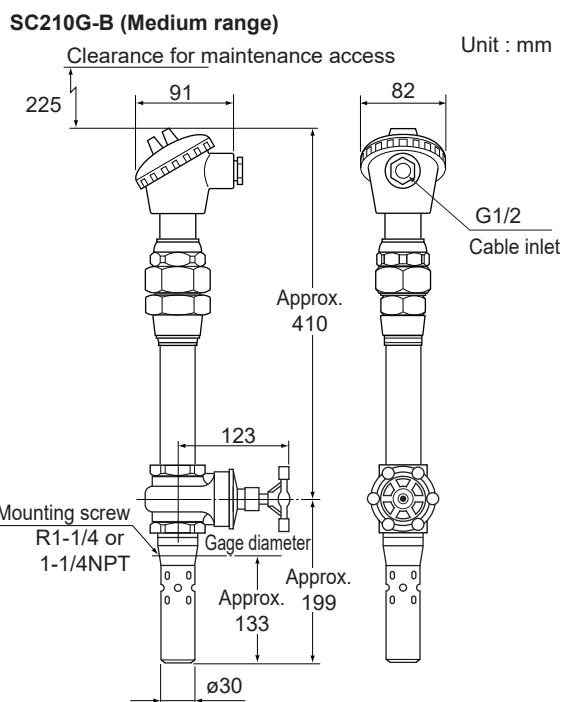
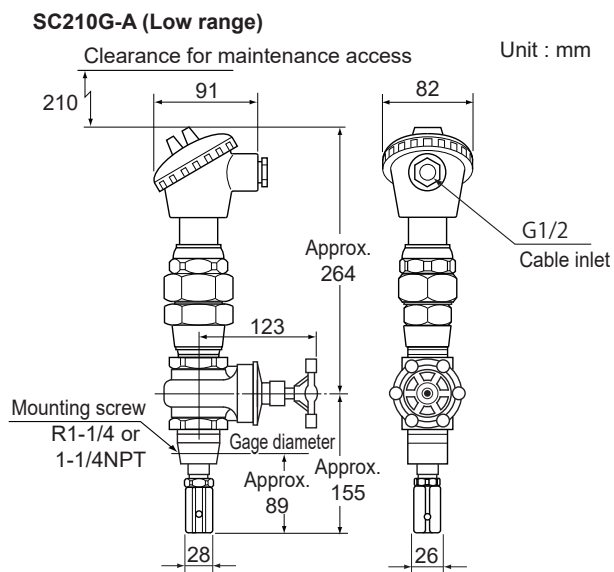

■ **WIRING DIAGRAM**

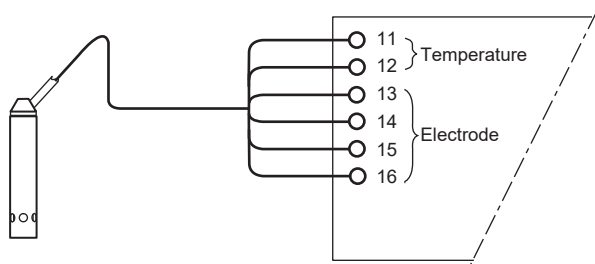

SC4AJ Conductivity Sensor
 (two-electrode system)
 Applicable Analyzer:
 FLXA402, SC450G, FLXA202, FLXA21

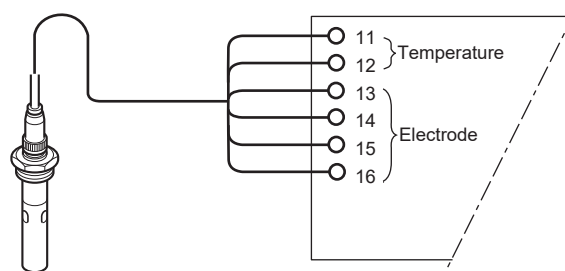

SC8SG Conductivity Detector
 (two-electrode system, four-electrode system)
 Applicable Analyzer:
 FLXA402, SC450G, FLXA202, FLXA21

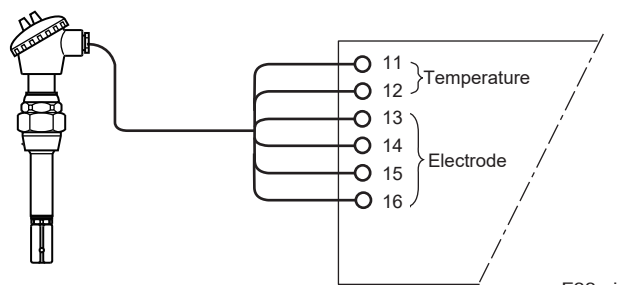

SC210G Conductivity Detector
 (two-electrode system)
 Applicable Analyzer:
 FLXA402, SC450G, FLXA202, FLXA21

F33.ai

■ TABLE OF CORROSION-RESISTANT MATERIALS

Note: This table shows corrosion resistances against each specified chemical only. If two or more kinds of chemical are mixed in a sample, the properties may be different from those shown in this table.

- ◎ Very suitable
- Suitable
- △ Slightly unsuitable
- × Unusable

Example of Description
Concentration Temperature
% °C

Judgement
◎

		Holder material			Electrode material				Seal O-ring material
		Polypropylene			316 SS		Epoxy resin		PVDF
Inorganic acids	Hydrochloric acid	5 20 ◎ 80 ◎	5 30 ×	5 30 ○ 10 60 ×	5 30 ◎ 1 30 ×			Strong acid ◎ Weak acid ◎	
	Hypochlorous acid	10 20 ◎ 40 ○	14 30 ×	15 30 ×	20 40 ◎				
	Nitric acid	10 20 ◎ 80 ◎	10 30 ◎	10 30 ◎ 25 60 ×	10 100 ○				
	Sulfuric acid	3 20 ◎ 3 100 ◎	5 30 ◎ 5 100 ×	5 20 ○ 10 60 ×	5 30 ◎ 5 100 ×				
	Phosphoric acid	30 60 ◎ 30 100 △	15 30 ◎ 5 b ◎	5 30 ◎ 25 100 ×	5 30 ◎ 5 60 ○				
Alkali	Ammonia water	15 80 ◎ 15 100 ○	10 b ◎ 28 65 ◎	10 b ◎ 28 65 ◎	10 b ◎ 28 65 ◎			Strong alkali × Weak alkali △	
	Caustic potash		10 b ◎ 25 b ◎	10 60 ○ 25 b ×	10 b ◎ 25 b ○				
	Caustic soda	20 80 ◎ 20 100 ◎	20 30 ◎ 20 b ◎	20 60 ◎ 20 b ×	20 30 ◎ 20 b ◎				
	Potassium carbonate		5 b ◎ 35 b ◎	5 b ◎ 35 b ◎	5 b ◎ 35 b ○				
	Sodium carbonate	sat. 100 ◎	25 b ◎	25 b ◎	25 b ◎				
Chlorides	Zinc chloride		20 b △	20 60 ○	20 b ◎				
	Aluminum chloride		25 25 × 25 25 ×		10 b ◎ 25 b ×				
	Ammonium chloride	35 40 ◎	25 b △	25 20 ○	25 b ◎				
	Potassium chloride		sat. 60 ◎	sat. 60 ◎	sat. 60 ◎				
	Calcium chloride	sat. 80 ◎ sat. 100 ◎	25 b ○	25 b ◎	25 b ◎				
	Ferric chloride	20 40 ◎ 60 ◎	30 b ×	30 60 ○ 100 ×	30 b ◎				
	Sodium chloride 20% + C12 (saturated) (Electrolyte)	100 ◎	90 ×	90 ×	90 ◎				
	Sea water	24 ◎	24 △	60 ○	24 ◎				
Sulfates	Ammonium sulfate	5 60 ◎	20 b ◎ sat. 30 ◎	20 b ◎ sat. 30 ○	20 b ◎ sat. 30 ◎				
	Potassium sulfate		10 b ◎	10 b ◎	10 b ◎				
	Sodium sulfate		20 b ◎	20 b ◎	20 b ◎				
Nitrates	Ammonium nitrate	Good corrosion resistance against all salts normally used	20 b ◎	20 b ◎	20 b ◎				
	Sodium nitrate		50 b ◎	50 b ◎	50 b ◎				
Others	Sodium sulfite		20 b ◎		20 b ◎				
	Hydrogen peroxide		10 30 ◎	10 30 ◎	10 30 ◎				
	Sodium hypochlorite	10 90 ◎ 20 80 ◎	2 60 to 90 ×	2 60 to 90 ×	15 30 ◎				
	Potassium bichromate		10 b ◎	10 20 ○	10 b ◎				
	Alcohol	96 70 ◎	100 b ◎	80 60 ○	80 100 ○				
	Acetic acid	100 70 ◎	100 70 ◎	10 60 ○	10 100 ○				
	Phenol	100 20 ◎	95 30 ◎	100 20 ×	100 20 ○				
	Aromatic solvent	100 20 ×	100 25 ◎	100 20 ×	100 ○				

(Note) b: Shows temperatures up to the boiling point. PVDF: Polyvinylidene difluoride

CAUTION



Select the material of wetted parts with careful consideration of process characteristics. Inappropriate selection may cause leakage of process fluids, which greatly affects facilities. Considerable care must be taken particularly in the case of strongly corrosive process fluid such as hydrochloric acid, sulfuric acid, hydrogen sulfide, and sodium hypochlorite. If you have any questions about the wetted part construction of the product, be sure to contact Yokogawa.

