

# General Specifications

## Industrial Electrodes for pH/Redox

Model SC25V/ SC24V/ SM21/ SR20/ SC21/ SM29 /SC29/ SM60

Selecting the proper pH electrode for an application can be a challenging exercise.

The heart of a pH measuring loop is the electrode system. Yokogawa has designed a wide range of electrodes to ensure this heart keeps beating under the most severe conditions.

The dimensions and design meet the requirements of DIN 19263 (excluding the refillable types). A high degree of standardisation makes it possible to mount any electrode in the standard program of fittings.

The combination of electrode plug and cable socket is watertight and temperature is resistant up to 125°C. It meets the requirements of IP65.

Colour coded strips on electrode, cable and clear identification of sensor specifications makes incorrect installation virtually impossible.

### Features

- Dome shaped membrane for "Heavy Duty" applications
- Wide range of electrodes to suit almost all process conditions
- Color codes strips for easy identification of electrodes and cables
- High degree of standardisation for mounting in various flow, insertion- and immersion fittings
- Separate electrode system for high accuracy applications
- Reference sensors with a junction made of ceramic, PTFE, pNa glass or Zirconium
- Combination electrode with external liquid earth



pH/Redox  
Analyzers

### System configuration

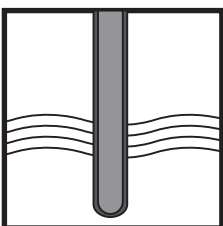

Sensors

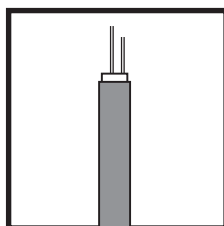

Cables

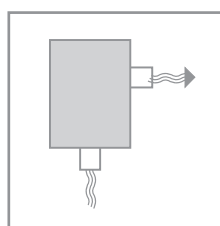

Fittings

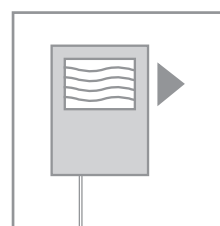



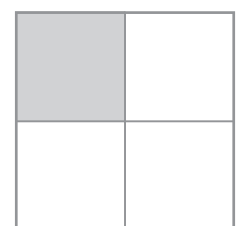





Transmitters



Accessories

Yokogawa Europe B.V  
Amersfoort, The Netherlands.

**Properties** **Petrochemical**

	pH range	ORP range (mV)	Minimum Conductivity (µS/cm)	Pressure range (bar)	Temperature (°C)	High process Temperatures	High process Pressures	Sour water Stripper (also Quench (lower) water)	After sour water stripper to demin tank	Cooling tower (corrosion control)	API Separator (waste water treatment)	Mono and Tri ethylene g/yo (meg/leg)
<b>SC24V</b> 	4-14			0-10	0-120	●	●	●				
<b>SC25V</b> 	0-14		>10	0-10	0-130	●					●	●
<b>FU20</b> 	0-14	-1500/1500	>50	0-10	0-105		●				●	
<b>FU24</b> 	0-14	-1500/1500	>10	0-10	0-105		●				●	
<b>SC21-AAP26</b> 	0-14		>50	0-5	0-110						●	
<b>SC21-ALP26</b> 	0-14		>50	0-5	10-120	●					●	
<b>SC21-AGP26</b> 	0-14		>50	0-5	-10-100						●	
<b>SC21C-AGC55</b> 	0-14		>0.05	0-10	0-100		●	●	●	●	●	●
<b>SC29C-PTG29</b> 		-1500/1500	>50	0-10	0-100		●					

● Best choice specifications of the PH20, FU20 and FU24 are in GS 12B6J3-E-E

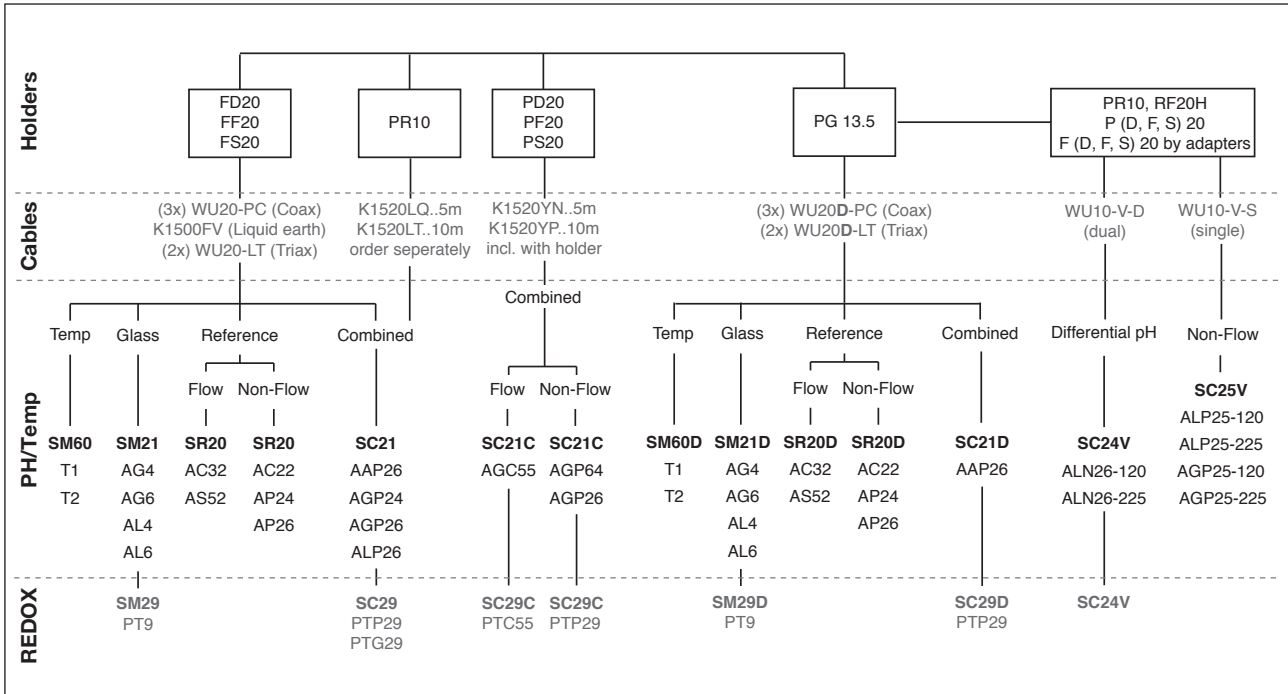

Note	Electrode	Mounting	Reservoir	Electrolyte	Thickened electrolyte
1	SR20-AC52 / SC21-AGC52	K1500BY	K1500FU	K1520VA	K1520VN
2	SR20D-AC52	included	K1500FU	K1520VA	K1520VN
3	SR20-AC32	FP20-S13	-	K1520VA	K1520VN
4	SR20D-AC32	FP20-S13D	-	K1520VA	K1520VN
5	SC21C-AGC55	included	K1520YA	K1520VA	K1520VN

GS 12B6J1-E-E

## Chemical

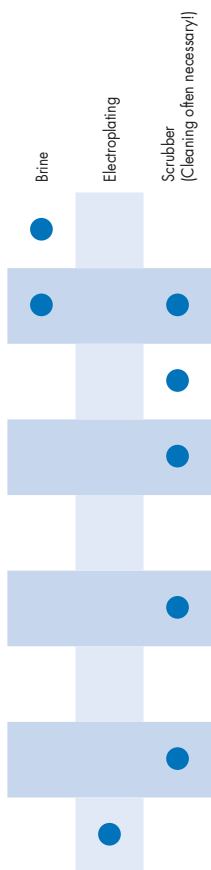

## Power

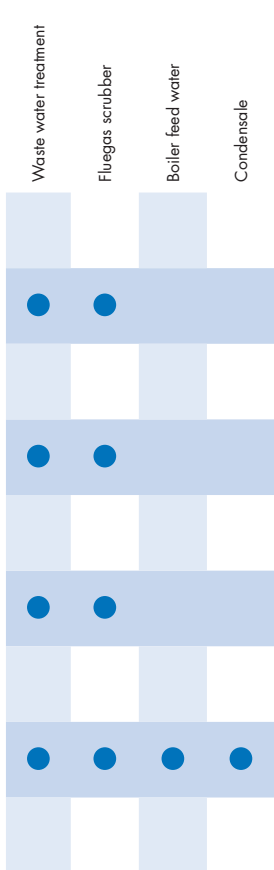

## Various

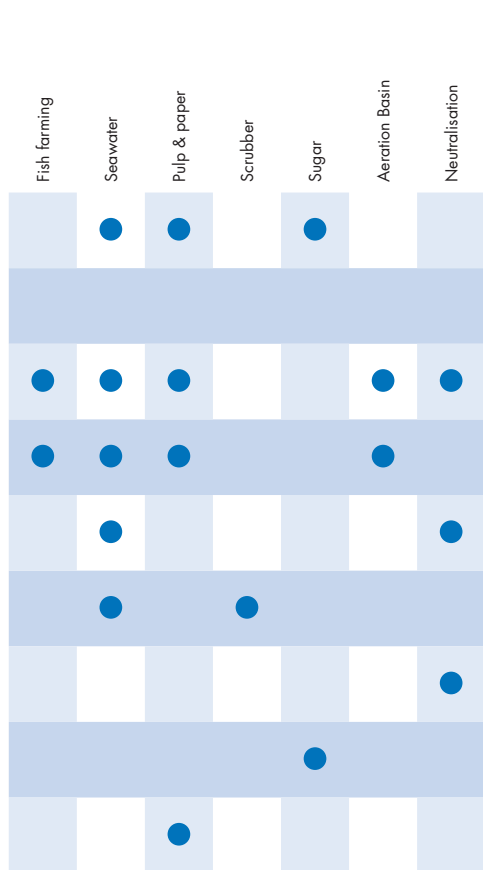

### What is a pH measurement ?

- Measure the amount of  $H_3O^+$  and  $OH^-$  ions
  - $2 \cdot 10^{-7}$  mol/l of the water molecules will dissociate
  - Adding  $H^+$  or  $OH^-$  will change this balance
  - $pH = -\log [H_3O^+] = -\log [1 \cdot 10^{-7}] = 7$
- Acids and bases when dissolved in water simply alter the relative amount of  $H_3O^+$  and  $OH^-$  ions in solution.

### $H_2O > H^+ + OH^-$ Water dissociation

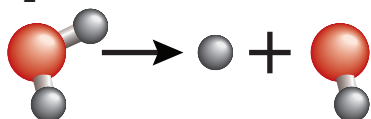

### How to measure pH ?

- pH sensitive glass
- Reference (potential) that is stable under all conditions
- Weak point: reference with open contact to the process
- Solution: select the proper electrodes for the application

### Maintenance and calibration

- For accurate measurement frequent maintenance is required
- Cleaning of the electrodes prior to calibration is important

pH can be measured in several ways, but it always consists of an element that is sensitive to the  $H^+$  concentration (usually glass), a reference electrode that, as the name suggests, produces a stable reference value (potential) at any given temperature. One can see that even the measurement itself is reliant on temperature. Therefore a pH electrode needs temperature input. As reference electrodes have an open connection to the process therefore subject to fouling, electrolyte depletion, etc., the system must be calibrated periodically to ensure accurate, repeatable measurements. Although calibration against one buffer typically ensures accurate pH readings, frequent two-buffer calibrations ensure the most reliable results. When selecting buffers, use buffers on either side of your pH value you will be measuring.

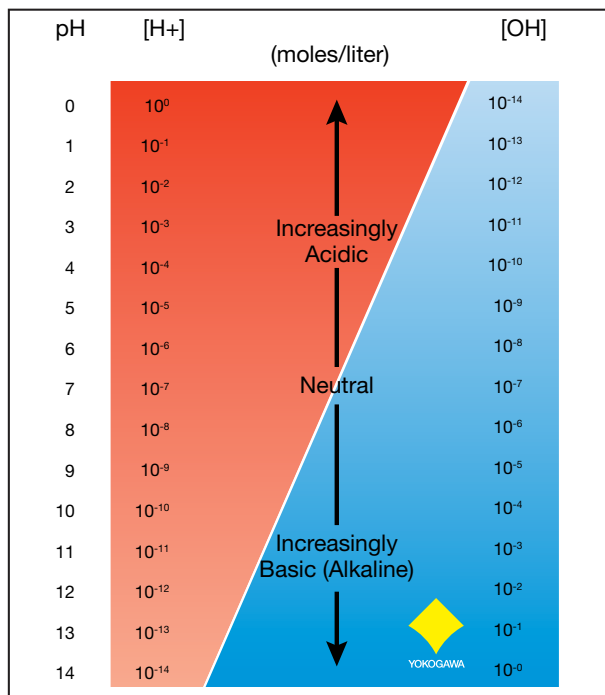

Buffer solutions are readily available. Realize that these should be traceable to national or international standards (IEC, NIST). As any solution, the pH value of buffers is dependant on temperature. For proper calibration each buffer should come with a temperature table. Yokogawa uses traceable buffers to NIST.

### Why use a temperature compensation ?

- pH changes with temperature
- Introduces error in the measurement
- Necessary for reliable control

### SC21 & SC25V Combined pH Electrodes (non-flow)

Yokogawa is continuously improving the present pH sensing portfolio and designing new pH sensors integrating the latest improvements into the new design and upgrading our present.

The SC25V is the latest addition to the family. Yokogawa's first combination pH sensor in a 12 mm design with an external Liquid earth. A new design made it possible to create a large electrolyte volume making this sensor last longer than most other comparable pH electrodes.

The SC21 series, already for many years Yokogawa's trusted range of combination pH electrodes, still has the same variety of choices making it easy to find the best electrode for each application.

#### Features SC25V

- External titanium Liquid Earth
- Pt1000 integration in pH compartment giving highly accurate temperature compensation
- ATEX certified : ATEX II1G Ex ia IIC T3...T6 Ga
- CIP and Steam cleaning possible
- Large internal KCl volume giving the sensor a longer life time
- Measuring in Pure Water applications from 10  $\mu$ S/cm
- Variopin connector
- SC25V-ALP25 for chemically harsh applications and high temperatures
- SC25V-AGP25 for all General Purpose applications

Model	Suffix Code	Option Code	Description
SC25V			Combined 12mm sensor: pH, Ref, LE, Temperature Equiped with Variopin connector
Sensor type	-AGP25 -ALP25		General purpose High temp: Chemical resistant
Sensor length		-120 -225	120mm 225mm

#### Specifications Combined pH electrodes with Temperature + Liquid earth

Type	Membrane	Resistance in $M\Omega/25^{\circ}C$	pH-range	Temp. range ( $^{\circ}C$ )	Pressure range kPa	Reference liquid	Diaphragm system	Ref.	Atex
SC25V-AGP25	Universal pH-glass bulb	175-275	0-14	-10 - 80	0-1000	Oversaturated KCl	Ag/AgCl (wire)	PTFE	Yes
SC25V-ALP25	Chem. Res. pH-glass dome	500-700	0-14	+15 - 130	0-1000	Oversaturated KCl	Ag/AgCl (wire)	PTFE	Yes

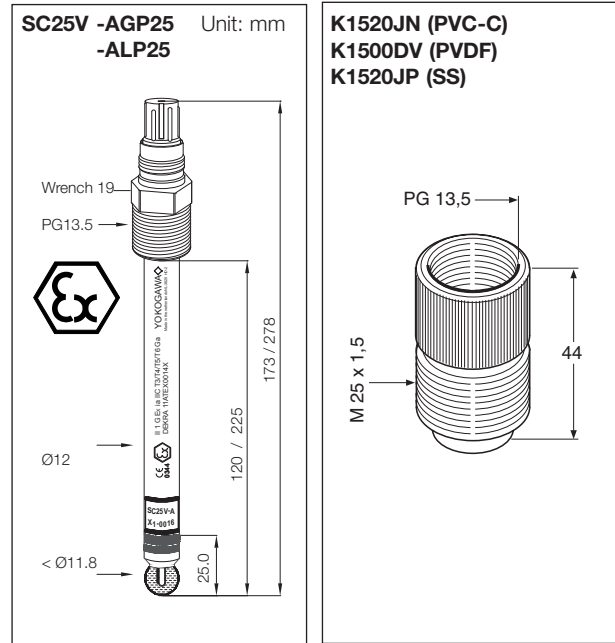

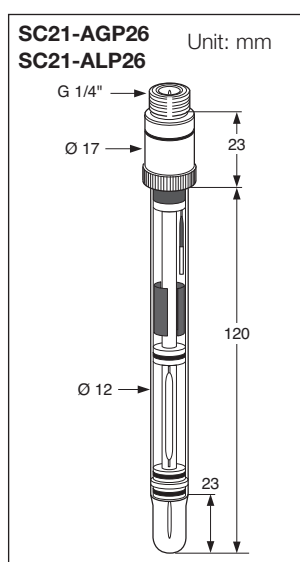
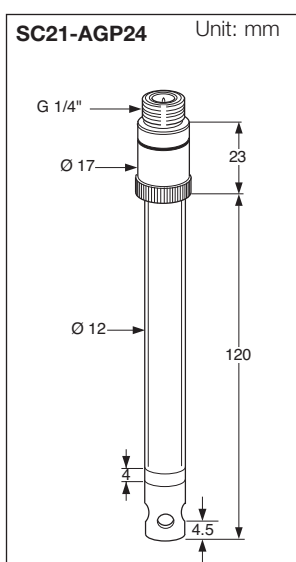
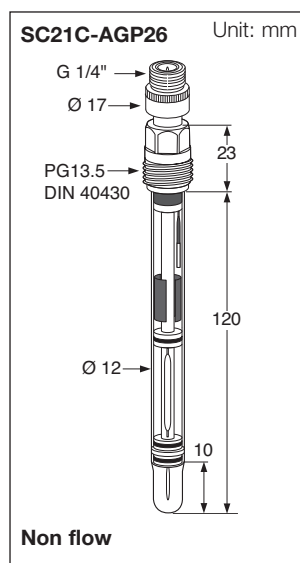
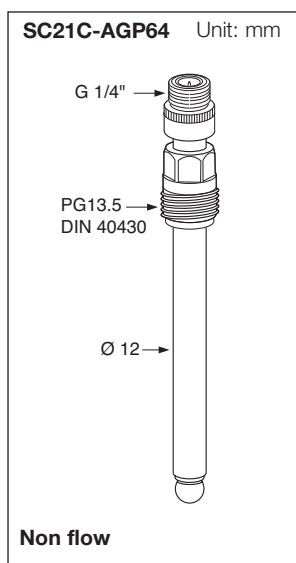

#### Characteristics of type SC21-AGP24

- Ag/AgCl wire reference system.
- pH bulb with cage protection
- Less maintenance due to the gelled electrolyte and porous PTFE.
- Thickened electrolyte (3.3 m.).

#### Characteristics of type SC21-AAP26

- High quality Ag/AgCl reference system (pin) which can stand high temperatures and temperature fluctuations.
- Built-in salt bridge to prevent poisoning of the reference system.
- A large area PTFE junction to resist fouling to a high degree.

#### Characteristics of type SC21(C)-AGP26

- High quality Ag/AgCl reference system (pin) which can stand high temperatures and temperature fluctuations.
- Double junction (thickened saturated KCl-solution). The built-in salt bridge prevents poisoning of the reference system.
- Heavy duty glass membrane for prolonged operation in corrosive, abrasive and fouling environments (withstanding traces of HF).
- A large area PTFE junction to resist fouling.

#### Characteristics of type SC21(C)-ALP26

- Chemical resistant, steam-sterilisable pH-glass.

#### Characteristics of type SC21C-AGP64

- Ag/AgCl wire reference system
- Less maintenance by the combination of gelled electrolyte and porous PTFE.
- 3.3 m KCl electrolyte

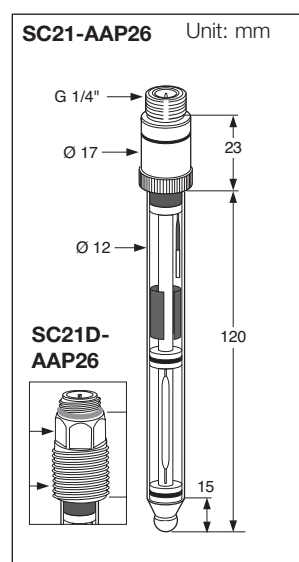

### Specifications Combined pH Electrodes (non-flow)

Type	Membrane	Resistance in M $\Omega$ /25°C	pH-range	Temp. range (°C)	Pressure range kPa	Reference liquid	Reference system	Diaphragm	Flow
SC21-AGP24	Universal pH-glass bulb	50 - 100	0 - 14	0 - 80	1-500	3.3 m. KCl Thickened	Ag/AgCl (wire) Silver-silverchloride	Porous PTFE	0
SC21(D)-AAP26	Chem. res. pH-glass bulb steam-sterillisable 3/4 bulb	250 - 400	0 - 14	0 - 110	1-500	Oversaturated KCl thickened	Ag/AgCl (wire) Silver-silverchloride	Porous PTFE	0
SC21-ALP26	Chem. res. pH-glass dome	500 - 900	0 - 14	10 - 120	1-500	Oversaturated KCl thickened	Ag/AgCl (wire) Silver-silverchloride	Porous PTFE	0
SC21-AGP26	Universal pH-glass bulb	120 - 200	0 - 14	-10 - 100	1-500	Oversaturated KCl thickened	Ag/AgCl (wire) Silver-silverchloride	Porous PTFE	0
SC21-AGP64	Universal pH-glass bulb	50 - 100	0 - 14	0 - 80	1-500	3.3 m. KCl Thickened	Ag/AgCl (wire) Silver-silverchloride	Porous PTFE	0

Model	Suffix code	Description 1	Description 2	Description 3
SC21(C/D)		pH/ref combination electrode		
Sensor type	-AGP24	General purpose	with protection cage	
Non-flow	-AGP64	General purpose	PG15,5 process com	
	-AAP26	General purpose	Double junction	High temperature electrode
	-AGP26	Heavy duty	Double junction	Moderate temperature
	-ALP26	Heavy duty	Double junction	High temperature electrode

GS 12B6J1-E-E

### SC24V Differential pH sensor

The SC24V is a differential pH sensor. This means that the reference is not a (liquid) junction but a glass sensor which does not respond to pH changes (within the applicable range of the sensor). Therefore the sensor is truly maintenance free and the output voltage of the sensor depends only on the salt concentration of the process.

The sensor responds to pH changes rather than analyzes the accurate pH value. In that sense it is best to describe the sensor as pH control sensor rather than pH measuring sensor.

A pH sensor measures the voltage that the pH membrane measures as function of the pH value of the process sample. This voltage is then compared with the mV output of a reference cell that is independent on the pH value of the sensor

In most pH control applications the salt concentration is rather constant, so the output of the SC24V differential sensor is only dependent on the pH of the process.

A rule of thumb is that a change in salt concentration of +/- 25% has an effect of less than 0.1pH on the pH reading.

Model	Suffix Code	Option Code	Description
SC24V			Combined 12mm 4 in 1 differential pHsensor with Variopin connector
Sensor	-ALN26		Ag/AgCl reference system, pH half cell L-glass, reference cell salt sensitive glass, non-flow, heavy duty
Sensor length		-120 -225	120mm 225mm

#### Features

- VP connector
- Sterilizable pH sensor
- No reference electrode or junction
- Maintenance free pH sensor
- No diffusion = high stability

K1520JN (PVC-C)  
K1500DV (PVDF)  
K1520JP (SS)

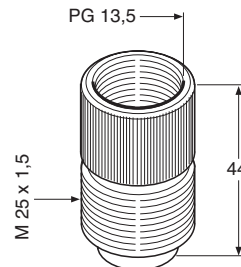

SC24V

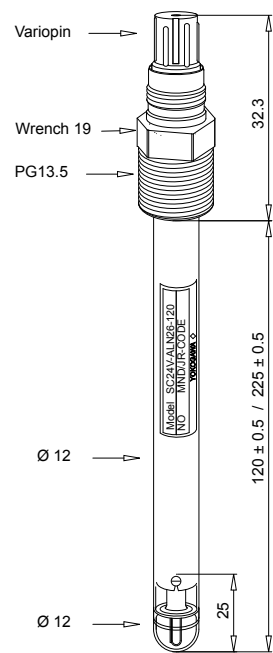

### SC21C Combined pH Electrodes (Flow)

This flowing electrolyte sensors uses a ceramic reference junction, with the electrolyte (3.3 molal KCl). The flow of electrolyte through the junction, while small, remains the safest way to prevent clogging and to protect the internal reference against poisoning and diffusion.

#### Features for type SC21C-AGC55

- For tough application where pollution of the reference system is to be expected
- Low ionic application where the positive flow of electrolyte provides the conductivity needed to measure pH (< 50  $\mu\text{S}/\text{cm}$ )
- Heavy duty pH sensitive glass.
- Flowing reference system for pollution resistance, and highly stable reference potential.
- PG13.5 standard DIN electrode connection.
- Adapter to ensure compatibility with full fitting program.
- Use in combination with the pressurisable electrolyte reservoir to obtain a positive flow towards the process (K1500YA)

For compatibility with the Yokogawa "Compact" range of electrode holders, the SC21C-AGC55 combined sensor, has a PG13.5 DIN connector. This also makes the sensor suitable for mounting in a wide range of industry standard equipment. The SC21C-AGC55 is supplied with a PG13.5 to M25 adapter (K1520JN) that makes the sensor compatible with the full Yokogawa fitting program. For temperatures higher than 85°C we recommend to use the PVDF version.

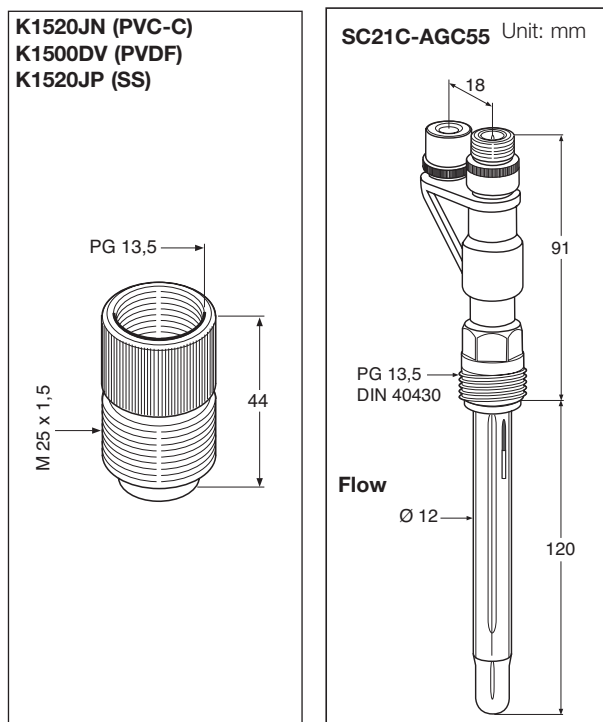

### Specifications Combined pH Electrodes (Flow)

Type	Membrane	Resistance in MOhm/25°C	pH-range	Temperature range (°C)	Pressure liquid	Reference system	Reference	Diaphragm	Flow
SC21-AGC55	Universal pH-glass dome (heavy duty)	120 - 200	0 - 14	0 - 100	1-500kPa (only with pressure reservoir)	3.3 m.. KCl	Ag/AgCl pin	Ceramic	max.0.5 ml per day at 10kPa overpressure

### SM29 Redox Electrodes

Redox measurements are a potentiometrical measurement of the oxidizing/reducing power of a liquid. To be able to measure this equilibrium of reversible redox reactions the electrodes used should be inert. Noble electrodes such as Platinum (Pt) and Gold (Au) are widely used for this purpose and seem to approximate the behaviour of an ideal inert electrode. Platinum is used most widely, has excellent chemical resistance but suffers slightly from chemisorption of Oxygen, which slows down its response.

The potential of reference electrodes is depending on their composition. A table with the actual values for each system is given next. All values refer to 25°C. The reference system is also indicated on the textplate of the electrode.

System	Fill solution	Value against Standard Hydrogen Electrode
Ag/AgCl	3.3 m. KCl	203 mV
Ag/AgCl	sat. KCl	196 mV

### Combined Redox Electrodes

For redox measurement Yokogawa offers non-flow general purpose electrodes and a heavy duty flow electrode. All electrodes are equipped with a solid platinum pin to provide long lifetime, even in processes that harm the platinum electrodes such as hypochloride.

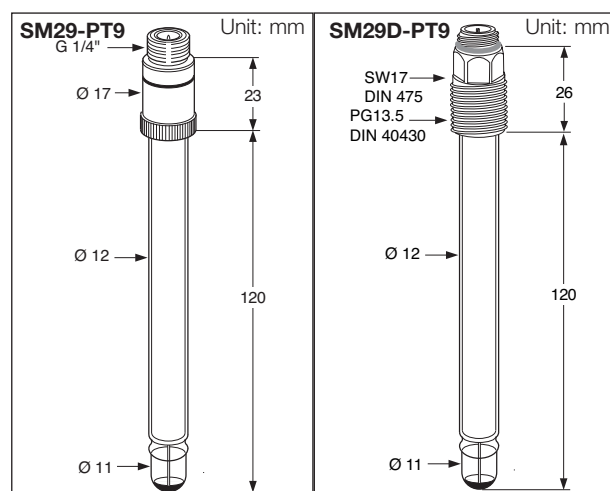

### SC29 Redox/pH

This combined electrode can be used in processes with a constant pH value or for processes where the Redox potential is dependent on the pH in order to achieve a pH compensated Redox potential. In such a case a pH/Redox converter with a high input is required. All pH/Redox converters of Yokogawa have such an input.

### SC29(C) Redox/Reference

#### Additional features for type SC29C-PTP29

- General purpose redox measurements
- Diaphragm resistance (25°C) < 5 kΩ
- High quality Ag/AgCl reference system (pin) which can stand high temperatures and temperature fluctuations
- Double junction, thickened saturated KCl-solution
- Built-in salt bridge prevents poisoning of the reference.
- Large area PTFE junction to resist fouling.

#### Additional features of type SC29-PTG29

- Bulb shaped glass membrane.
- Ag/AgCl wire reference system
- Glass Resistance (25°C): 50 to 100 MΩ

#### Additional features for types SC29C-PTC55

- Heavy duty pH sensitive glass.
- Flowing reference system for pollution resistance, and highly stable reference potential.
- PG13.5 standard DIN electrode connection.
- Adapter to ensure compatibility with full fitting program.

### Specifications Redox Electrodes

Type	Temperature range	Process pressure	Metal surface
SM29-PT9	0 - 130°C	max. 1000 kPa	Platinum
SC29C(D)-PTP29	-10 - 100°C	max. 500 kPa	Platinum
SC29-PTG29	0 - 100°C	max. 1000 kPa	Platinum
SC29C-PTC55	-10 - 100°C	max. 500 kPa	Platinum

#### Type coding

SC29 □ - □ □

#### Construction, Liquid outlet

- 2. = Non-flow
- .9 = Solid metal cup
- 55 = Heavy duty flow type

#### Diaphragm, Membrane

- P = PTFE (teflon) membrane
- G = Universal glass
- C = Ceramic

#### Metal

- PT = Platinum

#### Connector type

- = Yokogawa connector
- D = Din connector
- C = Compact connector

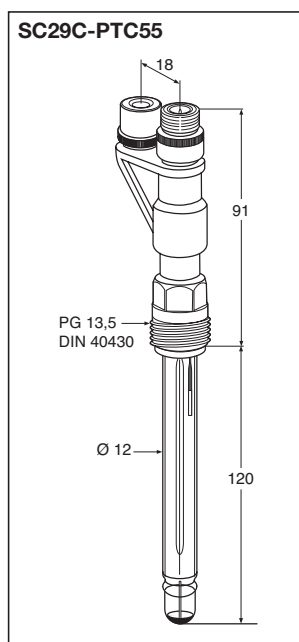
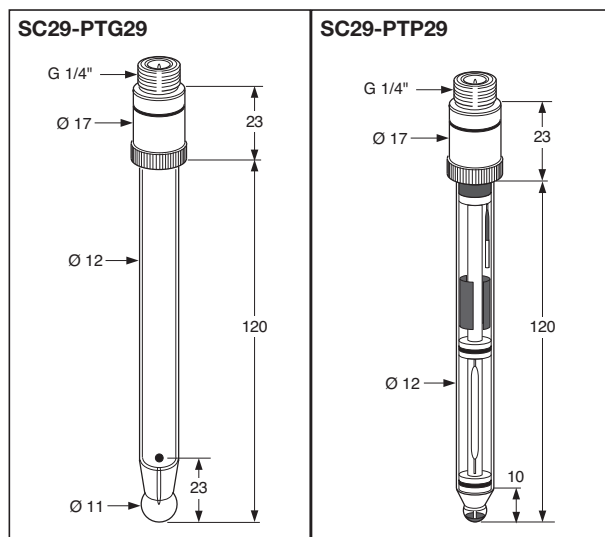
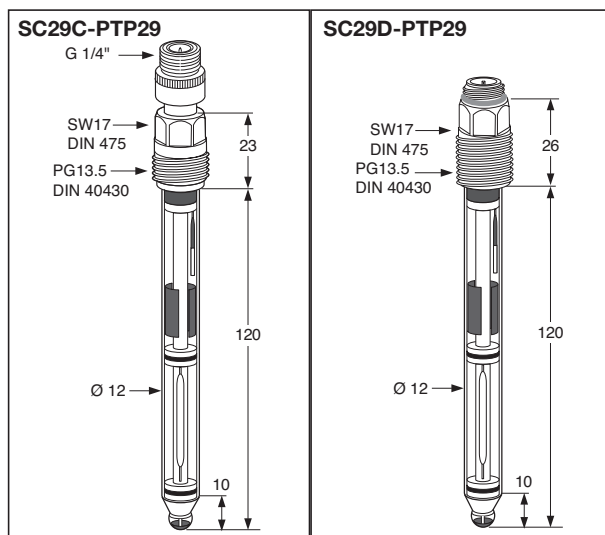

### SM21 Single Glass Electrodes

The glass membrane is the most important part of the complete pH measuring loop. pH sensitive glass has the particular property that alkali metal ions present in the texture of the glass are exchanged with H<sup>+</sup> ions of the liquid. The selection of the correct type of glass electrode depends on both the type of glass membrane thickness of the glass membrane.

Two types of glass are available, as described here:

#### "G" glass

This is used for the membranes of electrodes in processes where the nominal pH value varies between pH0 and pH10. Since this type of glass has a wide application range it is also termed "general purpose" glass.

#### "L" glass

The application of "L" glass is for measurements in alkaline media with high process temperatures.

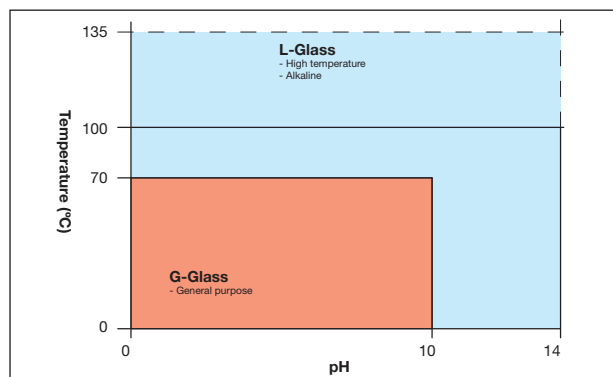

#### Features

- Low resistance glass for fast response and sensitivity
- High resistance glass for chemical resistance
- L-glass sensors for high temperature chemically harsh applications
- G-glass sensors for all general applications
- "All glass" construction.
- Dimensions and design meet the requirements of DIN 19263.
- Isothermal point of intersection: pH 7 (nominal value at 0 mV).
- Maximum pressure: 1000 kPa (10 bar).
- Metal foil screening.
- Bulb membrane for general purpose.
- Dome shaped membrane for "Heavy Duty" applications.

#### Thickness of the glass membrane

##### Shockproof

A bulb shaped glass membrane suitable for general purpose

##### Heavy duty

This dome shaped glass membrane is suitable for harsh and abrasive applications.

#### Selection guide separate electrodes : Glass sensors

modelcode	Bulb type	Glass resistance (Mohm)	T range (°C)	Pressure (bar)	Applications	remark
SM21(D)-AG2	Universal	25-50	0-80	10	light, laboratory	fast response, high sensitivity
SM21(D)-AG4	shockproof	50-100	0-100	10	general	Universal
SM21(D)-AG6	heavy duty	120-200	0-100	10	Harsh	mechanically strong
SM21(D)-AL4	shockproof	300-450	15-130	10	High Temperature	T cont. ≥ 70°C, high chem. Resistance
SM21(D)-AL6	heavy duty	600-900	25-130	10	High T + abrasive	T cont. ≥ 70°C, high chem. Resistance

\* all pH glass sensors have a sodium error of 0.17 pH above pH=13 this because the glass then will see the Na<sup>+</sup> ion as H<sup>+</sup> ion. The pH reading is lower than it is in reality.

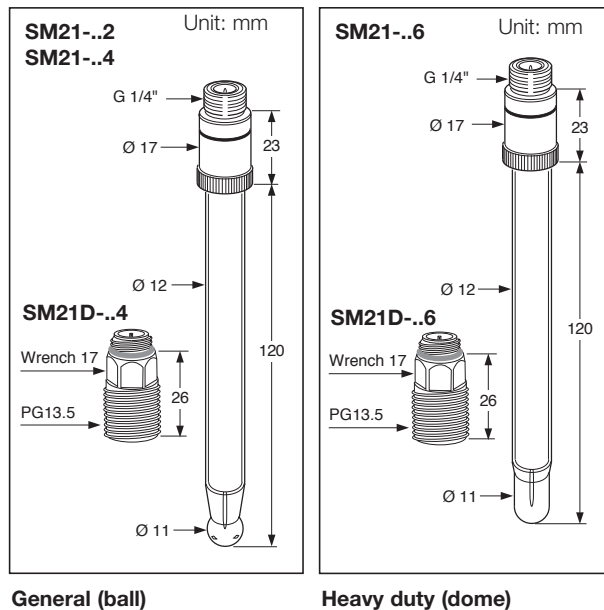

General (ball)

Heavy duty (dome)

#### Type coding

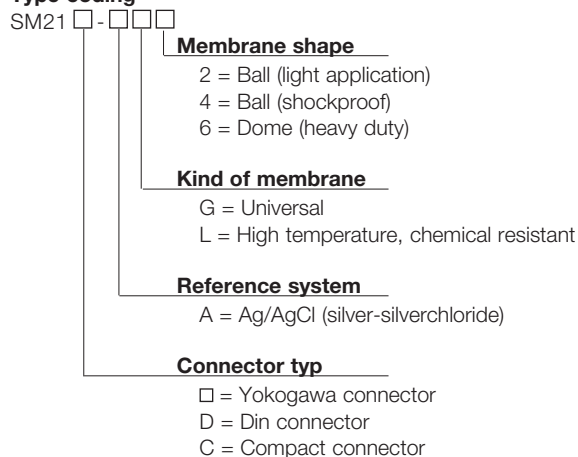

### SR20 Single Reference Electrodes (non-flow)

The selection of the correct type of junction of a reference electrode depends on the process conditions under which this electrode has to function. The following junction types are available:

1. Ceramic junction.
2. Glass sleeve capillary element.
3. PTFE junction.

The purpose of the junction is to maintain contact between the reference system in the electrode and the process liquid. When selecting the correct junction, consideration has to be given to ensure that the process liquid does not penetrate into the electrode causing poisoning and a consequential unstable liquid junction potential.

With the first two types of junction, listed above, the KCl solution flows slowly into the process. The flow rate is dependent on the over-pressure in the electrode and on the process temperature. The electrolyte flow rate increases with increasing temperature. For use in very dirty liquids a glass sleeve capillary element is preferred because of its larger flow surface. The sleeve can be easily cleaned by first moving the ground ring upwards and then wiping the ground faces. Non-flowing reference electrodes with a porous PTFE junction can also be used in many dirty liquid applications. The dirt resistant properties of PTFE will prevent complete fouling of the diaphragm.

A non-flow type reference electrode can be used for processes that don't contain components that poison the reference system. The gel-type electrodes have a large area of porous PTFE junction for optimal resistance against electrode pollution. The SR20-AP26 electrode is the optimal choice for processes that cannot stand contamination with KCl. The SR20-AC22 electrode has a flexible PTFE tube. Therefore this electrode can be applied in processes with frequent temperature- and pressure fluctuations.

#### Features

- Easy maintenance.
- No reference liquid wastage.
- Maximum process pressure: 1000 kPa (10 bar).
- High quality Ag/AgCl reference system (pin) which can stand high temperatures

#### Additional features of types SR20(D)-AC22

- Temperature / pressure variation compensation.
- To be used in non-polluting fluids.
- Saturated KCl-solution (pellets).
- For low ionic applications and high temperatures.
- Temperature range: 0 to 120°C.
- Diaphragm resistance (25°C) <5kΩ.

#### Additional characteristics of type SR20(D)-AP24

- General purpose PTFE diaphragm electrode.
- Large PTFE diaphragm.

#### Additional characteristics of type SR20(D)-AP26

- When KCl is prohibited in the application.
- Double junction, thickened KNO<sub>3</sub> in buffer compartment.
- Large PTFE diaphragm against pollution.

### Specifications Single Reference Electrodes (non-flow)

Type	Temperature range (°C)	Pressure (bar)	Reference liquid	Reference system Silver-silverchloride	Diaphragm	Diaphragm resistance/25°C
SR20(D)-AC22	0 - 120	10	Saturated KCl-solution (pellets)	Ag/AgCl (pin)	Ceramic	< 5 kOhm
SR20(D)-AP24*	0 - 80	10	Thickened KCl (3.3 m.)	Ag/AgCl (pin)	PTFE	< 5 kOhm
SR20(D)-AP26*	0 - 80	10	Thickened KCl (3.3 m.) Thickened KNO <sub>3</sub> (3.3 m.)	Ag/AgCl (pin)	PTFE	< 5 kOhm

\* In application where high process temperature occur together with very low (<2) or very high (>12) PH levels the lifetime is shortened.  
GS 12B6J1-E-E

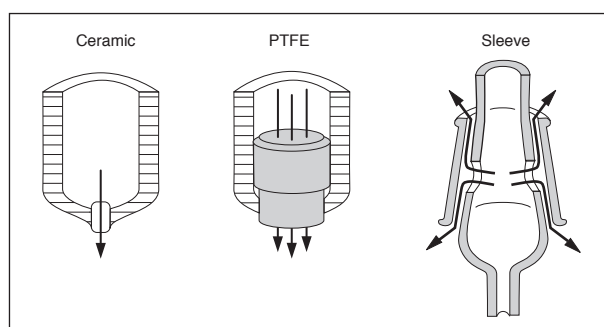
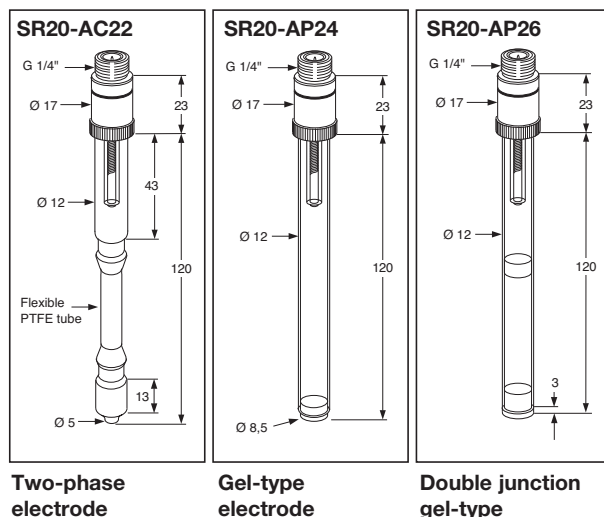

#### Type coding

SR20 □ - □ □ □

#### Liquid outlet

##### Non-flow

- 22 = PTFE hose filled with KCl pellets
- 24 = Filled with thickened electrolyte
- 26 = Double junction filled with gelled Gel-type electrodeelectrolyte

##### Flow

- 11 = Refillable laboratory reference electrode
- 32 = Process pressure compensated
- 52 = Refillable at the top

#### Diaphragm

- C = Ceramic
- P = PTFE (porous)
- S = Sleeve

#### Reference system

- A = Ag/AgCl (silver-silverchloride)

#### Connector type

- = Yokogawa connector
- D = Din connector
- C = Compact connector

## SR20 Single Reference Electrodes (flow)

### Pressure compensated Reference Electrode

In processes with pressure variations, the composition of the electrolyte may change as a result of process liquid penetration into the electrode. Any change in composition of the electrolyte may cause a measuring error or even poisoning of the reference system of the electrode. To alleviate this problem, the electrode with an integral pressure compensation system ("Bellomatic"-type electrode") may be the solution.

### Reference electrode

- Flowing type sensors for dirty applications or (Ultra) pure water applications (often needs a electrolyte reservoir)
- Non-flow type sensors for all general applications
- Ceramic and PTFE junction : electrolyte flows slowly into the process. PTFE resists dirt
- Glass sleeve : very dirty applications or for (Ultra) pure water applications because of the larger flow-rate

### Features

- Liquid flow output preventing diaphragm fouling and poisoning the reference system.
- High quality Ag/AgCl reference system (pin) which can stand high temperatures and temperature fluctuations.
- Standard 3.3 m. KCl electrolyte, at temp. above 70°C thickened electrolyte is advised.
- Automatic compensation for process pressure variations.
- Chemical resistant Viton Bellow material.
- Constant flow of reference liquid, independent of the process pressure variations for minimal diffusion potential.
- Suitable for pure water applications and for polluting fluids.
- Refillable, large KCl reservoir.

### Note:

The flow is highly dependent on temperature. When using the electrode continuously at temperature over 70°C it is recommended to fill the electrode with a reference liquid having a higher viscosity, ordernr. K1520VN (3.3 m. KCl).

### The electrode function is as follows:

The electrolyte vessel of the electrode contains a bellow which is compressed in the working position. One side of the bellow is connected to the pressure via the ceramic junction and at the other side via the inner tube. The pressure inside the bellow equals the pressure outside and only the elasticity of the bellow itself causes the over-pressure which results in a flow of electrolyte. When the bellow is fully "expanded" the electrolyte is exhausted and refilling is required. The bellow must be compressed before refilling.

The refillable reference electrodes have a positive flow of electrolyte to prevent junction fouling or poisoning of the reference system. To prevent penetration of the process liquid into the electrode the pressure in the electrode must be higher than the process pressure. The ceramic junction is suitable for most applications. In strong polluting processes a sleeve junction is preferable.

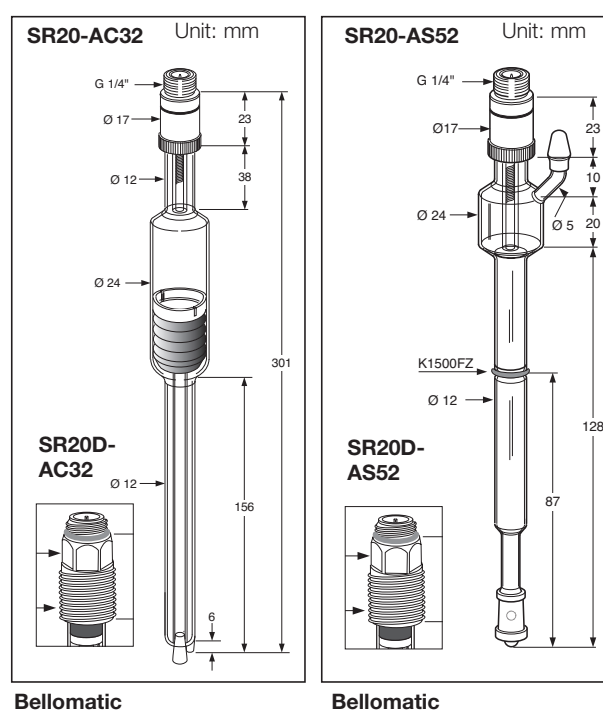

### Specifications Single Reference Electrodes (flow)

Type	Temp. range (°C)	Pressure range	Reference liquid	Reference system	Diaphragm	Diaphragm resistance/25°C	Flow at 25°C
SR20(D)-AS52	0 - 100	Atmospheric	KCl-solution (3.3 m.)	Ag/AgCl (pin) Silver-silverchloride	Sleeve	< 10 kOhm	Max. 0.2 ml/day at 10 kPa overpressure
SR20(D)-AC32	0 - 120	0 - 1 MPa	KCl-solution (3.3 m.)*	Ag/AgCl (pin) Silver-silverchloride	Ceramic	< 10 kOhm	Max. 0.5 ml/day*

## Mounting Kit for SR20-AC32

### type FP20-S13

This mounting kit is used whenever a refillable electrode with a large KCl reservoir is to be fitted in a flow or immersion fitting.

### Specifications

#### Materials

Electrode mounting set	: Ryton R4
Body	: stainless steel (AISI 316)
Screw piece	: stainless steel (AISI 316)
O-rings	: silicone
Rings	: silicone
Weight	: approx. 120 g

### Ordering Instructions

Type nr.	Description
FP20-S13	Mounting kit for SR20-AC32
K1500HC	Rubber ring (10x)
K1500GE	O-rings (5x) for "BELLOMATIC" electrode

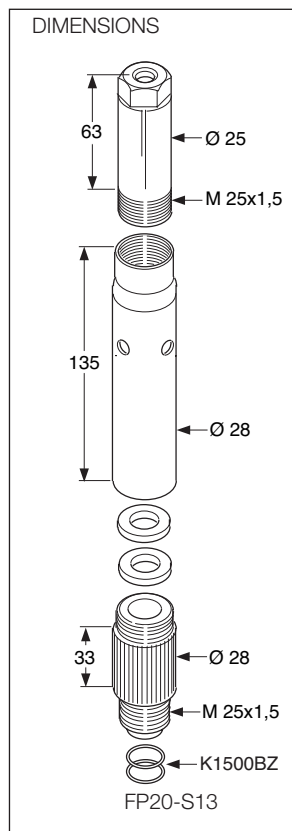

## SM23 single pNa electrode

The SM23 is suitable for long term, reliable Sodium ion monitoring. Another application is to use the pNa sensor as reference electrode for pH measurement in combination with and analyzer with dual high input impedance specification. This may considerably save maintenance costs in application where the salt content is constant and  $\text{pH} > \text{pNa} + 2$ .

pNa measurement is used in many applications, but the most frequent applications are found in pure water applications, where Sodium is measured to detect carry-over of salts in steam, leakage of salt through cation filters, Leakage of salt from leaking condensers.

Other applications where the pNa electrode is used for measurement is in brine solutions. Please note that accurate measurement requires that the pH is 2-3 units higher than the pNa value.

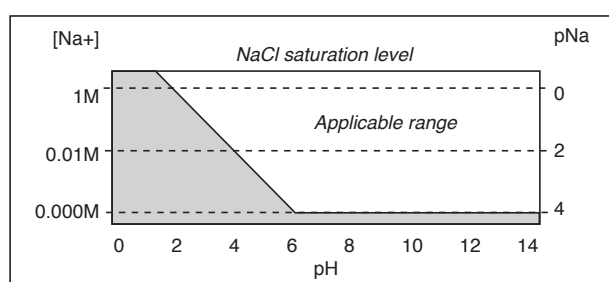

### Features

- Dimensions and design meet the requirements of DIN 19263
- Temperature range 0 – 100°C
- Shockproof and heavy-duty (dome shaped) membranes
- pNa range < 0 to 4
- pH 2 units higher than the pNa ( $\text{pH} - \text{pNa} > 2$ )
- $\text{Na}^+$  range is 0.0001M up to saturation

### Additional characteristics for type SM23-AN4

- Glass resistance @ 25°C 100-300M $\Omega$
- Suitable (Ultra-, pure-) water application
- Shock-proof glass membrane with fast response

### Additional characteristics for type SM23-AN6

- Glass resistance @ 25°C 450 - 700M $\Omega$
- heavy-duty membrane guarantees great strength retaining the necessary sensitivity
- Especially suitable for the more harsh processes. For example brine applications

## Specifications Single pH Glass Electrodes

Type	Membrane in M $\Omega$ /25°C	Resistance* range	pH range	Temperature (°C)	Reference system	Sodium error 0,1 N[Na-]/25°C
SM23-AN4	Universal pNa-glass bulb (shockproof)	100-300	*	0 - 100	Ag/AgCl (pin)	n.a.
SM23-AN6	Universal pNa-glass bulb (heavy duty)	450-700	*	0 - 100	Ag/AgCl (pin)	n.a.

\* pNa range < 0 to 4 (0.0001M up to saturation) and pH 2 units higher than the pNa ( $\text{pH} - \text{pNa} > 2$ )

**Note:** The resistance may not exceed 1000 M $\Omega$  under measuring and calibrating conditions (according DIN the resistance of the glass may not exceed 1G $\Omega$ ). As a general rule, the glass-resistance will increase by 100% with every temperature decrease of 10°C (likewise, the glass impedance will decrease by 50% with every temperature increase of 10°C).

### Type coding

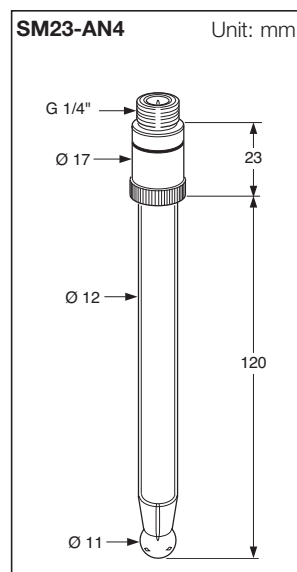
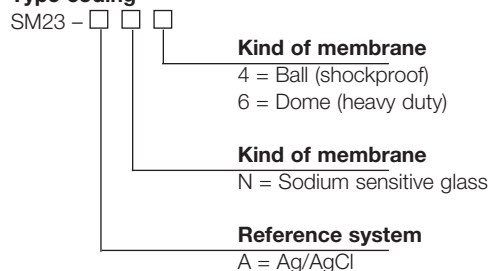

Shock proof AN4

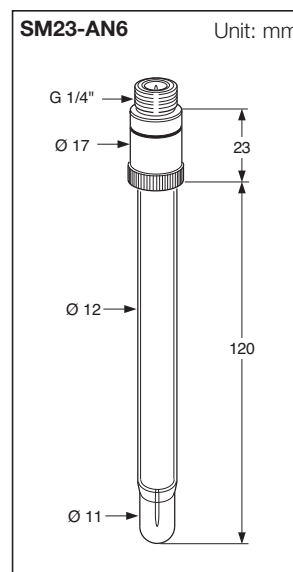

Heavy duty AN6

### Electrolyte Reservoirs for F..20 fittings

The purpose of the electrolyte reservoir is dual. By mounting the electrolyte reservoir at a certain distance above the electrode, the pressure on, the reference liquid in an electrode and hence, the liquid outlet of the electrode, can be increased. The amount of electrolyte is increased, so less refilling is required. The reservoir can be connected to the electrode by a silicone tube. For fixing on top of an immersion fitting a screw thread  $\frac{1}{2}$ " BSPP at the lower end of the reservoir is available.

### Specifications

Material	: PVC, PVC (transparent)
Temperature	: max. 70°C
Tube connection	: $\varnothing$ 10
Screw thread	: $\frac{1}{2}$ " BSPP

### Ordering Instruction

Model	Description
SB20-VC	Ceramic Junction
SB20-VP	Porous PTFE Junction
SB20-VS	Glass Sleeve Junction

### SB20 Salt Bridge

This reference electrode/salt bridge combination allows the measurement of pH or redox in those cases when:

- Excessive contamination of the reference diaphragm or poisoning of the reference system is expected. The flow of the reference liquid through the diaphragm is increased by pressuring the container. The distance to the reference system is increased. Consequently, the contamination rate will decrease.
- The process can not be contaminated with KCl. The salt bridge can be filled with several types of electrolytes.
- Measurement has to be performed at processes up to 1000 kPa (10 bar) and temperatures up to 100°C. As the reference electrode is mounted in the container and therefore in more favourable conditions, the lifetime will be extended reasonably. The container with reference liquid can be pressurised.

### FLOW TUBE (A)

Material	: glass
Flow diaphragm	: ceramic, PTFE or sleeve
Connector	: Ryton R4

### TUBING (B)

Material	: nylon
Diameter	: $\frac{1}{4}$ " o.d.
Length	: 5 or 10 mtr.

### CONTAINER (C)

Container	: PVC, PVC (transparent)
Electrode mounting set	: Ryton R4
"O" ring	: silicone
Connection	: nylon
Weight	: approx. 300 g.
Mounting	: wall mounting (screw M5)
Temperature/pressure ratio	: max. 200 kPa (2 bar) at 100°C

The normal standard reference electrodes can be mounted in the container. This reference electrodes can be ordered separately. For standard applications the SR20-AP24 is most suitable.

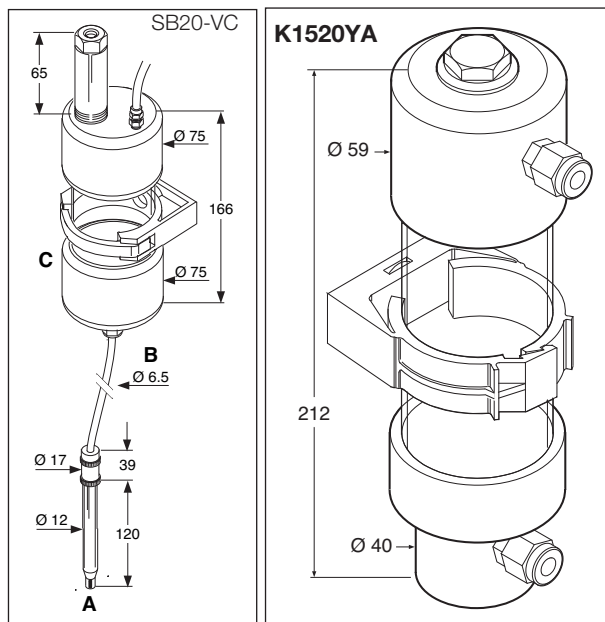
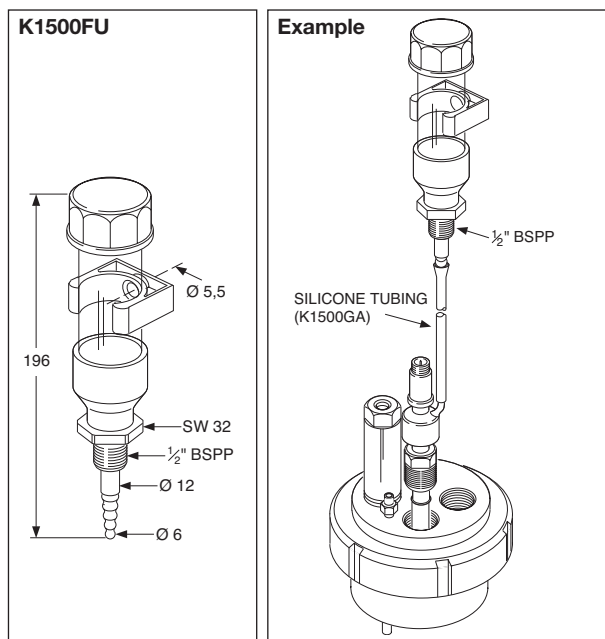

## SM60 Temperature Sensor

For accurate pH measurement temperature compensation is required. Either a Pt100 or a Pt 1000 temperature electrode can be selected.

### Type coding

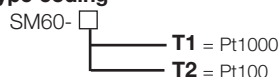

### Specifications Temperature Sensor

Type	Temperature sensor	Pressure range	Temperature range
SM60-T2	Pt100	0 - 1 MPa	-20 - 150°C
SM60-T1	Pt1000	0 - 1 MPa	-20 - 150°C

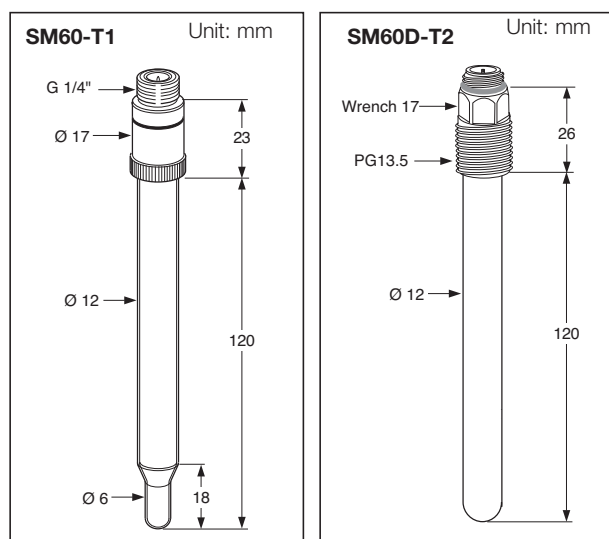

### SM60 Temperature Sensor table

Pt100		Pt1000	
°C	Ohm	°C	Ohm
-25	90,15	-25	901,5
-20	92,13	-20	921,3
-15	94,10	-15	941,0
-10	96,07	-10	960,7
-5	98,04	-5	980,4
0	100,00	0	1000,0
5	101,95	5	1019,5
10	103,90	10	1039,0
15	105,85	15	1058,5
20	107,80	20	1078,0
25	109,74	25	1097,4
30	111,68	30	1116,8
35	113,61	35	1136,1
40	115,54	40	1155,4
45	117,47	45	1174,7
50	119,40	50	1194,0
55	121,32	55	1213,2
60	123,24	60	1232,4
65	125,26	65	1252,6
70	127,08	70	1270,8
75	129,00	75	1290,0
80	130,91	80	1309,1
85	132,81	85	1328,1
90	134,70	90	1347,0
95	136,60	95	1366,0
100	138,50	100	1385,0
105	140,40	105	1404,0
110	142,29	110	1422,9
115	144,18	115	1441,8
120	146,07	120	1460,7

### Spare Parts SC21

Part no.	Description
K1500BZ	O-rings Viton 11x3 (6Pcs)
K1500GF	1 Molal KCl solution (250 ml)
K1500GG	1 Molal KCl solution (250 ml), thickened
K1520BB	Three bottles with NIST buffer 2.68 pH (replacing 6C231)
K1520BC	Three bottles with NIST buffer 4.01 pH (replacing 6C232 and K94...)
K1520BD	Three bottles with NIST buffer 6.86 pH (replacing 6C237 and K94...)
K1520BE	Three bottles with NIST buffer 9.18 pH (replacing 6C234 and K94...)
K1520JN	Adapter M25x1.5 - PG13.5
K1520VA	3.3 molal KCl solution (250 ml.)
K1520VN	3.3 molal KCl solution (250 ml.), thickened

### Spare Parts SR20(D)

Part no.	Description
K1500BZ	O-rings Viton 11x3 (6Pcs)
K1500FZ	O-rings 10x4 5pcs SR20-AC52
K1500GE	O-ring sets (5x). SR20(D)-.C32/52
K1500GF	1 Molal KCl solution (250 ml)
K1500GG	1 Molal KCl solution (250 ml), thickened
K1520VA	3.3 molal KCl solution (250 ml.)
K1520VN	3.3 molal KCl solution (250 ml.), thickened

### Spare Parts SB20

Part no.	Description
K1500BW	Flow tube for SB20-VC
K1500DW	Set of 12 cable nuts for WU20
K1500DV	Mounting adapter PG13.5 - M25 (PVDF)
K1500DX	5 m tubing for SB20
K1500EE	Flow tube for SB20-VP
K1500EF	Flow tube for SB20-VS
K1500FU	Electrolyte reservoir (SR20-A.52 / SC21-A.C52) (includes 2.5 mtr. silicon tubing)
K1500GA	5 mtr silicon tubing (7x4mm od,id)
K1500GF	1 Molal KCl solution (250 ml)
K1500GG	1 Molal KCl solution (250 ml), thickened
K1500GR	O-rings silicon 11x3 8pcs
K1500HD	O-rings silicon 11x3 50pcs
K1520JN	Mounting adapter PG13.5 - M25 (PVC-C)
K1520VA	3.3 molal KCl solution (250 ml.)
K1520VN	3.3 molal KCl solution (250 ml.), thickened

GS 12B6J1-E-E

## WU20(D) Cables for Industrial Applications

When you need optimal pH or Redox measuring results, the complete measuring loop not only requires highly qualified sensors and transmitters but also the special purpose sensor cables.

The program of Yokogawa includes a range of high quality, low-noise cables for accurate transmission of low voltage signals even in areas where interference is present. They have a shield with an internal anti-noise sheath and can be connected to all pH and ORP (Redox) electrodes fitted with an O-connector.

At the electrode end the cables are provided with a socket having spring gilded contacts for secure connection to the sensor.

The combination electrode plug and cable socket is watertight and temperature resistant up to 125°C. It meets the requirements of IP 65.

### Features

- Internal anti-noise sheath for accurate measurement.
- Gold plated spring O-connectors parts, for good electrical contact under the most severe conditions.
- Coaxial plug and socket with watertight sealing that meets the requirements of IP 65.
- Cables for industrial applications and for laboratory use are available.

### Coax Cables

These cables are for connecting to **single or combined** sensors fitted with an O-plug. For use at higher temperature specifications (up to 110°C continuously or 125°C for short times) and the most severe conditions.

### Triax Cables

These cables are for connecting to **combined** sensors fitted with an O-plug or to **single** sensors with an O-plug for use in areas where electrical interference is present. They have both inner, and outer shielding. In areas where electrical interference is likely we recommend to use the Triax electrode cable type WU20(D)-LT. marked with a blue strip.

### Notes:

1. For industrial applications the cables can be colour coded with the following marks:
  - Measuring electrode : red
  - Reference electrode : yellow
  - Temperature electrode: green
  - Combined electrode : blue
 Adhesive markers are provided for this purpose and should be fitted to both ends of the cables.
2. To secure optimal conditions, the cables may not be damaged or shortened. For protection of the cables there are special hoses available of 5 or 10 mtr. (K1500CJ, K1500CK respectively)
3. Suitable for use in intrinsically safe areas.

### Specifications

<b>Bending radius</b>	: min. 50 mm
<b>Max. temperature</b>	
- type WU20(D)-PC	: 110°C (continuously) 125°C (for short times)
- type WU20(D)-LT	: 70°C (continuously)
<b>Wire connections</b>	: 2 mm contact pins

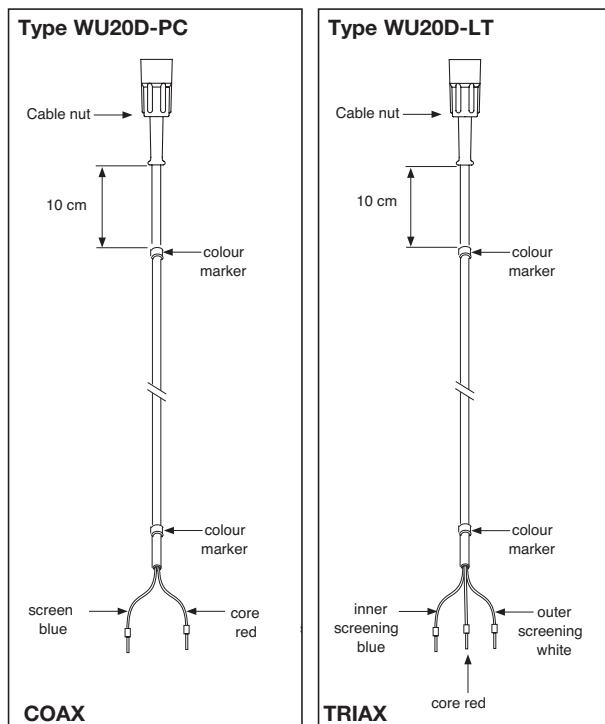
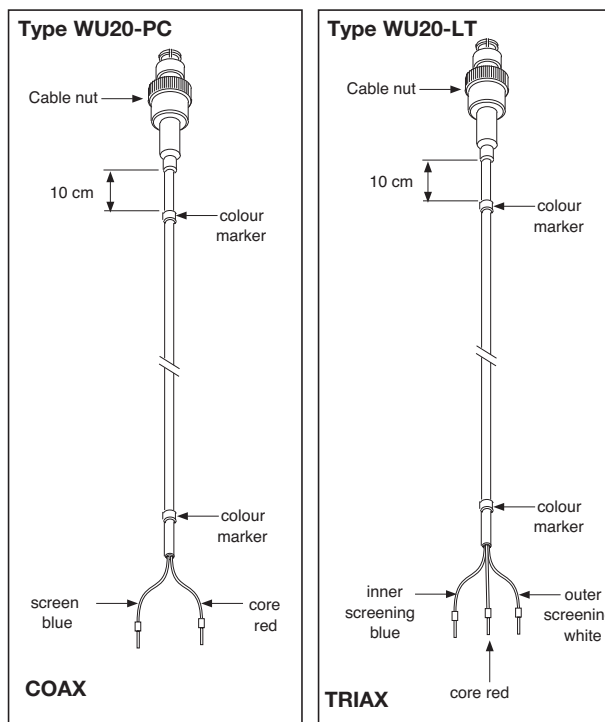

Model	Suffix code	Description
WU20(D)		Electrode cable
Type	-PC	COAX
	-LT	TRIAx
Length in m	01	1 mtr
	02	2 mtr
	05	5 1/2 mtr
	10	10 mtr
	15	15 mtr
	20	20 mtr
	25	25 mtr

## Specifications WU10-V-S-□-□

### Single Coax

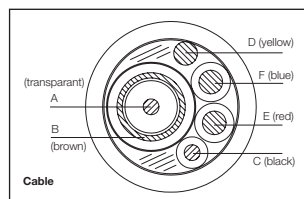

Figure 1

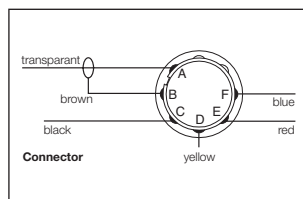

Figure 2

Description	: Multi core shielded cable with one low-noise coax and three insulated wires
Max. temperature	: 90 °C continuously and 105 °C for max. 1000 hr.
Sheath	: PVC
Colour	: Black
Diameter	: 6.5 mm
Internal insulation	: HDPE (Polyethylene)
Isolation resistance	: > $1.5 \times 10^{13}$ Ohm between E, F and overall shield > $0.5 \times 10^{13}$ Ohm between D and overall shield > $1.5 \times 10^{14}$ Ohm between A and overall shield
Capacity	: <100 pF/m between A and overall shield <120 pF/m between A and B <350 pF/m between B and overall shield
Resistance	: <100 Ohm/km for A <45 Ohm/km for wire C, E and F <100 Ohm/km for wire D
Coaxial cable	: Brown Thermoplastic Rubber sheath. : After termination core lead insulation transparent and shield insulated with brown cover : Diameter 3.3 mm
Wire D	: Bare drain wire covered with Yellow insulation after termination (overall shield)
Wire C	: Black cover diameter 1.2 mm
Wire E	: Red cover diameter 1.5 mm
Wire F	: Blue cover diameter 1.5 mm

## Specifications WU10-V-D-□-□

### Dual Coax

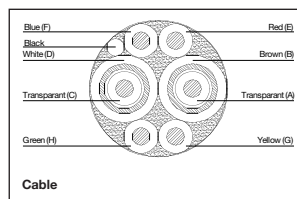

Figure 3

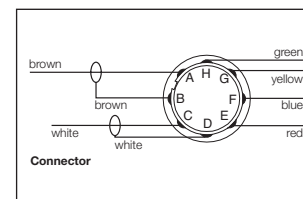

Figure 4

Description	: Multi core shielded cable with two low-noise coaxes and four insulated wires
Max. temperature	: 105 °C continuously and 125 °C for max. 3000 hr.
Sheath	: Thermoplastic Rubber sheath copper stabilized
Colour	: Black
Diameter	: 7 mm
Internal insulation	: Thermoplastic Rubber sheath copper stabilized
Isolation resistance	: > $1.5 \times 10^{13}$ Ohm between E, F, G, H and overall shield > $0.5 \times 10^{13}$ Ohm between black wire and overall shield > $1.5 \times 10^{14}$ Ohm between A and overall shield
Capacity	: <90 pF/m between A, C and overall shield <120 pF/m between A and B and between C and D <350 pF/m between B, D and overall shield
Resistance	: <100 Ohm/km for A and C <45 Ohm/km for wire C, E and F <100 Ohm/km for wire D
Coaxial cables	: Brown or white Thermoplastic Rubber sheath copper stabilized. : After termination core lead insulation transparent and shield insulated with brown or white cover : Diameter 2.7 mm
Black wire (drain)	: Bare drain wire covered with Black insulation after termination (overall shield)
Wire E	: Red cover diameter 1.4 mm
Wire F	: Blue cover diameter 1.4 mm
Wire G	: Yellow cover diameter 1.4 mm
Wire H	: Green cover diameter 1.4 mm

Flame retardant in accordance to IEC 60332-1

### Model and Suffix codes

Model	Suffix Code	Description
WU10		Sensor cable
Connector type	-V	Variopin
Cable type	-S	Single Coax
	-D	Dual Coax
Cable length	-02	2 meters
	-05	5 meters
	-10	10 meters
	-15	15 meters
	-20	20 meters

GS 12B6J1-E-E

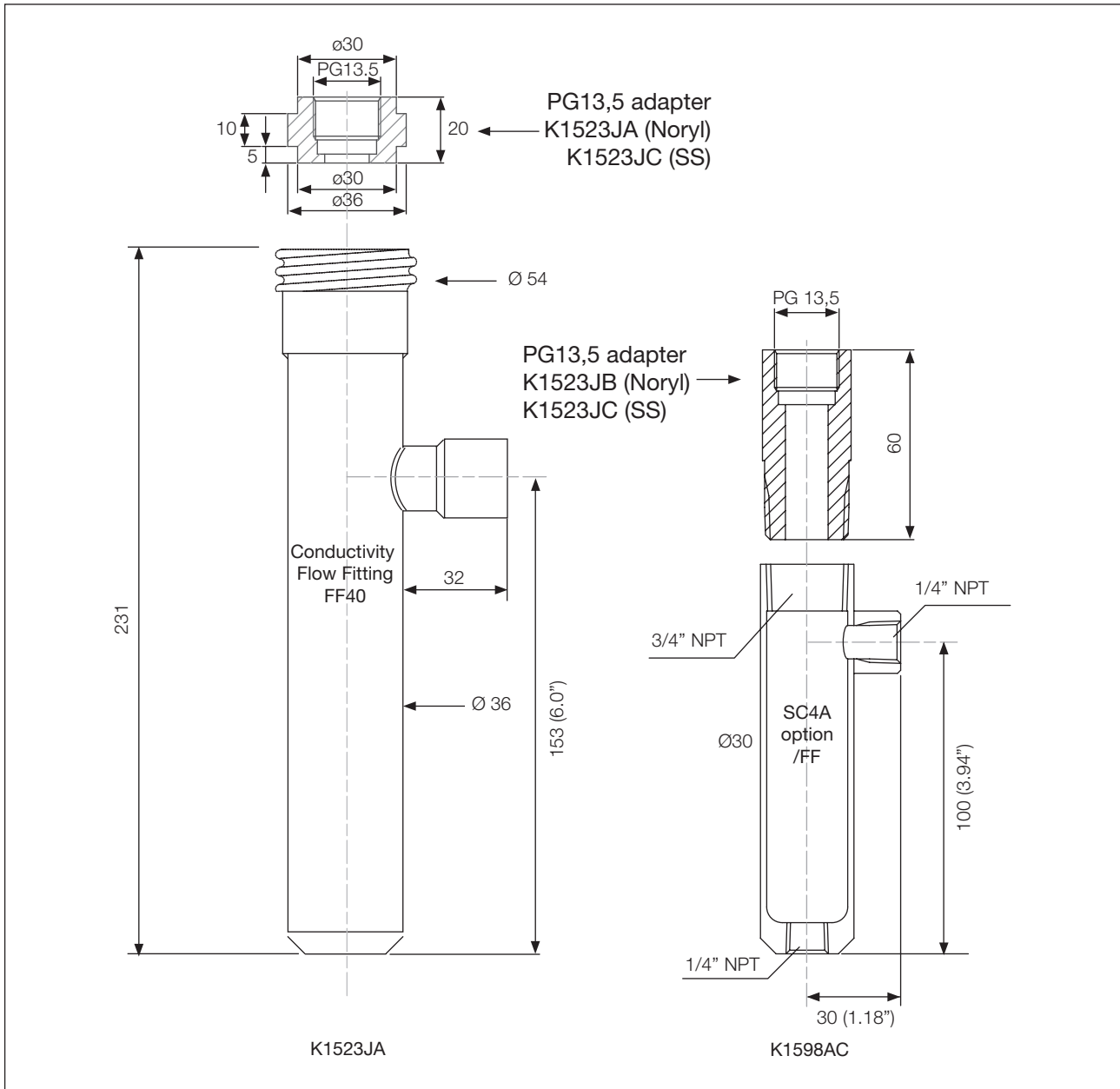

**Adapter to fit sensors with a PG13,5 process connection in FF40/FS40 and FD40 fittings. Material: Polypropylene**  
**K1523JA Noryl adapter PG13,5**  
**K1523JC Stainless Steel adapter PG13,5**

**Stainless Steel Flow fitting option /FF K1598AC (incl. 3.1 B certificate) with Adapter K1523JB (Noryl) or K1523JD (SS) to fit sensors with PG13,5 process connection**

**YOKOGAWA HEADQUARTERS**  
 9-32, Nakacho 2-chome,  
 Musashinoshi  
 Tokyo 180  
 Japan  
 Tel. (81)-422-52-5535  
 Fax (81)-422-55-1202  
 www.yokogawa.com

**YOKOGAWA CORPORATION OF AMERICA**  
 2 Dart Road  
 Newnan GA 30265  
 United States  
 Tel. (1)-770-253-7000  
 Fax (1)-770-251-2088  
 www.yokogawa.com/us

**YOKOGAWA EUROPE B.V.**  
 Euroweg 2  
 3825 HD AMERSFOORT  
 The Netherlands  
 Tel. +31-88-4641 000  
 Fax +31-88-4641 111  
 E-mail: info@nl.yokogawa.com  
 www.yokogawa.com/eu

**YOKOGAWA ELECTRIC ASIA Pte. Ltd.**  
 5 Bedok South Road  
 Singapore 469270  
 Singapore  
 Tel. (65)-241-9933  
 Fax (65)-241-2606  
 www.yokogawa.com/sg

Yokogawa has an extensive sales and distribution network. Please refer to the European website ([www.yokogawa.com/eu](http://www.yokogawa.com/eu)) to contact your nearest representative.



**YOKOGAWA** ◆