

# General Specifications

## Sensor Holders

GS 12J05C02-00E

### ■ GENERAL

Various types of analyzers are used to control quality and wastewater in a wide variety of production processes. Holders are used to set up analyzers at sites of measurement. Yokogawa provides several types of holders, for which cleaners can be added, allowing customers to build reliable and easy-to-maintain measuring systems by selecting the right holders and cleaners for the conditions of applications.

The submersion type holders PH8HS, PH8HSF and DOX8HS are widely used with process analyzers and can be directly immersed in reaction tanks or measuring baths for measurement. The DOX8HS for dissolved-oxygen meters or MLSS meters has a skew-cut tip to prevent air bubbles from accumulating on the tip of a sensor.

The flow-through holders PH8HF, PH8HFF and FH350G can be set up at a point along pipelines to measure solvent in production lines or wastewater pipelines.

Unlike with submersion type holders that require the entire holder assembly to be pulled up, the suspension holder HH350G has a guide pipe along which just a fitting-mounted sensor can be separately pulled up with a chain, thus increasing the ease of maintenance.

The inclined float holder, PB350G is equipped with a float that moves up and down in accordance with the fluctuating water surface level. Since the float has been designed to accommodate a sensor without extreme projections and depressions, the amount of foreign matter building up around the float or sensor decreases, and it becomes harder for dirt to accumulate, thus enabling continuous stable measurement over a long period. We have provided the vertical float holder, PB360G, for cases when the installation space for a float holder is limited or the measuring bath is covered. If however, there is no flow, neither float holder is recommended.



### ■ FEATURES

#### Submersion Type Holders: PH8HS, PH8HSF and DOX8HS

- Available in stainless steel or polypropylene.
- Optional jet- or ultrasonic-cleaning device (unavailable for DOX8HS).
- Optional flange fitting for PH8HS, PH8HSF.
- Skewed mounting for DOX8HS to prevent influence from bubbles.

#### Flow-Through Holders: PH8HF, PH8HFF and FH350G

- Available in stainless steel or polypropylene.
- Optional jet- or ultrasonic-cleaning device (unavailable for FH350G).
- Allows direct mounting to the pipeline.

#### Suspension Holder: HH350G

- Allows the sensor to be pulled up separately.
- Easy maintenance.
- Optional jet-cleaning device.

#### Float Holder: PB350G and PB360G

- Continuous stable measurement without effect from fluctuations in fluid level.
- Reduces maintenance frequency.
- Easy-to-maintain.
- Vertical type is also available for limited installation space.

FLEXA, FLXA are trademarks or registered trademarks of Yokogawa Electric Corporation.

All other company and product names mentioned in this document are trademarks or registered trademarks of their respective companies.







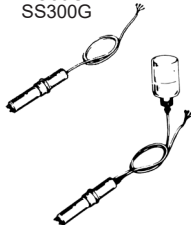

Please select appropriate equipment in accordance with the laws and regulations of the relevant country/region, when it is used in a location where explosive atmospheres may be present.

## SYSTEM CONFIGURATION

For the pH/ORP converter and sensors, see GS 12B07B02-E.

For the FLXA202, see GS 12A01A03-01EN. For the FLXA21, see GS 12A01A02-01E. For the FLXA402, see GS 12A01F01-01EN. For the dissolved oxygen converter and sensor, see GS 12J05D02-00E.

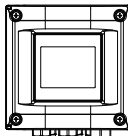
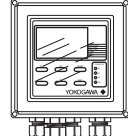
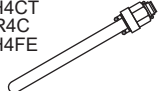
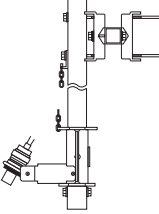
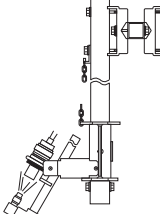
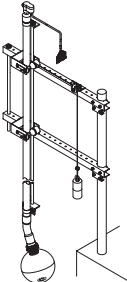
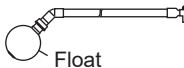
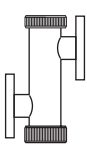
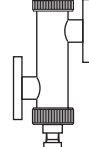
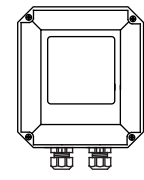
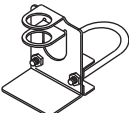
For the MLSS converter and sensors, see GS 12E6A1-E.

Sensors	Holders, Holders with Cleaning System	Converters
PH8ERP PH8EFP OR8ERG OR8EFG DO30G SS300G 	<ul style="list-style-type: none"> <li>● Guide Pipe PH8HG </li> <li>● Submersion Type Holder PH8HS                No Cleaning  With Cleaning </li> <li>● Submersion Type Holder DOX8HS                No Cleaning  With Cleaning </li> </ul>	FLXA202/FLXA21 FLXA402 SS400G  
PH4P PH4PT OR4P PH4F PH4FT PH4C PH4CT OR4C PH4FE 	<ul style="list-style-type: none"> <li>● Suspension Type Holder HH350G                &lt;No Cleaning&gt;  &lt;With Jet Cleaning&gt; </li> <li>● Vertical Floating Ball Holder PB360G </li> <li>● Angled Floating Ball Holder PB350G                Float </li> <li>● Flow-Through Type Holder PH8HF, FH350G                No Cleaning  With Cleaning </li> </ul>	
Accessories  Calibration reagents and KCl solution 		Cleaning Devices <ul style="list-style-type: none"> <li>● PUS400G</li> </ul>

System Configuration (General Purpose, Non-Explosionproof Types)

### CAUTION



Select the material of wetted parts with careful consideration of process characteristics. Inappropriate selection may cause leakage of process fluids, which greatly affects facilities. Considerable care must be taken particularly in the case of strongly corrosive process fluid such as hydrochloric acid, sulfuric acid, hydrogen sulfide, and sodium hypochlorite. If you have any questions about the wetted part construction of the product, be sure to contact Yokogawa.

### CAUTION



Installation Location of Holders (Guide Pipe, Submersion Type, etc)  
 The holder should be used in a place that is as vibration free as possible.  
 Using the holder in a place where it is affected by vibration, may result in damage to the holder.

## ■ SPECIFICATIONS

### 1. Guide Pipe PH8HG

Applicable sensors:

General pH Sensor PH8ERP, PH8EFP  
 General ORP Sensor OR8ERG, OR8EFG  
 Dissolved Oxygen Sensor DO30G  
 MLSS Sensor SS300G

Note: When using a KCl filling type sensor, a stanchion or mounting bracket is required separately.

Mounting: 2-inch pipe mounting vertical or horizontal.

Note: Make sure the mounting pipe is rigid and firmly installed.

Pipe length: 2 m

Material:

Holder; Polypropylene or PVC  
 Mounting bracket; Galvanized iron or stainless steel (304 SS)

Weight:

Holder; "-PP"; approx. 1 kg  
 "-PV"; approx. 1.6 kg

Mounting bracket; Approx. 1 kg/set

Measuring temperature: -5 to 50°C (PVC)  
 -5 to 80°C (Polypropylene)

### 2A. Submersion Type Holder PH8HS

Applicable sensors:

General pH Sensor; PH8ERP, PH8EFP,  
 PH4 Sensor; PH4P, PH4PT, PH4F,  
 PH4FT, PH4C, PH4CT

General ORP Sensor; OR8ERG, OR8EFG  
 OR4 Sensor; OR4P, OR4C

Note: An adapter is required when using PH4/OR4 sensor. When using with special pH/ORP sensor or PH4/OR4 sensor, this holder cannot be used outdoors due to exposure to rain or due to condensation at a high humid place.

Mounting: 2-inch pipe mounting vertical or horizontal with 1 or 2 set of mounting bracket

Note: Make sure the mounting pipe is firmly installed.

Cleaning method: Jet cleaning, brush cleaning or ultrasonic cleaning

Note: Brush cleaning and ultrasonic cleaning cannot be used when PH4/OR4 sensor.

Material:

Holder; Polypropylene or stainless steel (316 SS)  
 Flange; Polypropylene (refer to dimensions) or stainless steel (316 SS)

O-ring; Fluoro rubber (FKM) or Perfluoroelastomer (FFKM)

Mounting bracket; Galvanized iron or stainless steel (304 SS)

Cleaning unit (wetted parts):

Ultrasonic; Stainless steel (316 SS), titanium or Hastelloy C

Jet; Polypropylene

Brush; Polypropylene, titanium (shaft), Rulon (bearings)

Weight:

Holder; Approx. 0.5 to 5 kg (polypropylene)  
 Approx. 1.5 to 11.5 kg (stainless steel)

Mounting bracket; Approx. 1 kg/set

Flange; Approx. 0.5 to 1.8 kg (polypropylene)  
 Approx. 2.9 to 15.6 kg (stainless steel)

Temperature range:

No Cleaning; -5 to 100°C

With Cleaning; -5 to 80°C

Note: The temperature range may be limited by the specifications of the sensor.

Flow rate: 2 m/s or less

Note: The flow speed may be limited by the specifications of the sensor.

Measuring pressure: Submersion depth 3m max.

Note: The pressure may be limited by the specifications of the sensor.

Utility required for cleaning unit:

Type	Pressure (kPa)	Flow Rate
Water jet	200 to 400 + Liquid pressure	5 to 20 L/min
Water brush	100 to 250 + Liquid pressure	20 to 30 L/min
Air jet	200 to 400 + Liquid pressure	100 to 300 NL/min
Air brush	150 to 250 + Liquid pressure	300 to 600 NL/min

Note 1: Pressure and flow rate must be simultaneously satisfied at the holder inlet port.

Note 2: A large braid-reinforced tube of  $\phi 22 \times \phi 15$  is recommended for supply due to the flow rate.

### 2B. Submersion Type Holder (Explosionproof Type) PH8HSF

The holder is used only when using ultrasonic cleaning system in the explosionproof area.

Use PH8HS when using no cleaning, jet cleaning or brush cleaning.

Applicable sensors:

General pH Sensor PH8ERP, PH8EFP  
 General ORP Sensor OR8ERG, OR8EFG

Mounting: 2-inch pipe mounting vertical or horizontal with 1 or 2 set of mounting bracket.

Note: Make sure the mounting pipe is firmly installed.

Cleaning method: Ultrasonic cleaning

Material:

Holder; Polypropylene or stainless steel (316 SS)  
 Flange; Polypropylene or stainless steel (316 SS)  
 O-ring; Fluoro-rubber (FKM) or Perfluoroelastomer (FFKM)

Mounting bracket; Galvanized iron or stainless steel (304 SS)

Cleaning unit (wetted parts):

Ultrasonic; Stainless steel (316 SS), titanium or Hastelloy C

Construction: TIIS flameproof type (for d2G4 gas)

Cable entrance port of terminal box; G 3/4

Weight:

Holder; Approx. 2.2 to 3.2 kg (polypropylene)  
 Approx. 3.3 to 5.7 kg (stainless steel)

Mounting bracket; Approx. 1 kg/set

Flange; Approx. 1.5 kg (polypropylene)  
 Approx. 15 kg (stainless steel)

Temperature range: -5 to 80°C

Note: The temperature may be limited by the specifications of the sensor.

Flow rate: 2 m/s or less

Note: The flow speed may be limited by the specifications of the sensor.

Pressure: Submersion depth 3 m max.

Note: The pressure may be limited by the specifications of the sensor.

### 2C. Submersion Type Holder DOX8HS

Applicable sensors:

Dissolved Oxygen Sensor DO30G, DO70G

MLSS Sensor SS300G

Mounting: 2-inch pipe mounting vertical or horizontal, with 1 or 2 set of mounting bracket.

Note: Make sure the mounting pipe is firmly installed.

Cleaning method: Water or air jet cleaning  
(The wiper cleaning of MLSS meter should be specified on the sensor).

Material:

Holder; Polypropylene or stainless steel (316 SS)

O-ring; Fluoro rubber (FKM)

Mounting bracket; Stainless steel (316 SS) or galvanized iron

Cleaning unit (wetted parts); Polypropylene

Weight:

Holder; Approx. 0.5 to 3.6 kg (polypropylene)  
Approx. 1.5 to 11.5 kg (stainless steel)

Mounting bracket; Approx. 1 kg/set

Temperature range: 0 to 80°C

Note: The temperature may be limited by the specifications of the sensor.

Flow rate: 2 m/s or less.

Note: The flow rate may be limited by the specifications of the sensor.

Utility required for cleaning unit:

Pressure. Water jet; 100 to 200 kPa  
Air jet; 100 to 200 kPa

Flow rate. Water jet; 5 to 20 L/min  
Air jet; 10 to 20 NL/min

Note 1: Pressure and flow rate must be simultaneously satisfied at the holder inlet port.

Note 2: A large braid-reinforced tube of  $\phi 22 \times \phi 15$  is recommended for supply due to the flow rate.

### 3A. Flow-Through Type Holder PH8HF

Applicable sensors:

General pH Sensor; PH8ERP, PH8EFP, PH8ECP

PH4 Sensor; PH4P, PH4PT, PH4F, PH4FT, PH4C, PH4CT

General ORP Sensor; OR8ERG, OR8EFG

OR4 Sensor; OR4P, OR4C

Note: An adapter is required when using PH4/OR4 sensor. When using with PH4/OR4 sensor, this holder cannot be used outdoors due to exposure to rain or due to condensation at a high humid place.

Mounting: 2-inch pipe mounting vertical or horizontal, with 1 set of mounting hard bracket.

Note: Make sure the mounting pipe is firmly installed.

Cleaning method: Jet cleaning, brush cleaning or ultrasonic cleaning

Note: Brush cleaning and ultrasonic cleaning cannot be used when PH4/OR4 sensor.

Material:

Holder; Polypropylene, stainless steel (316 SS), Heat-resistant PVC or Titanium

O-ring; Fluoro rubber (FKM), Perfluoroelastomer (FFKM), Fluororesin coated

Mounting bracket; Stainless steel (304 SS)

Cleaning unit (wetted parts);

Ultrasonic; Stainless steel (316 SS), titanium or Hastelloy C

Jet; Polypropylene

Brush; Polypropylene, titanium (shaft), Rulon (bearings)

Weight:

Holder; Approx. 0.4 to 1.7 kg (polypropylene)  
Approx. 3 to 6.1 kg (stainless steel)

Mounting bracket; Approx. 0.5 kg

Temperature range:

No Cleaning; -5 to 80°C (polypropylene)  
-5 to 105°C (stainless steel)

With Cleaning; -5 to 80°C

Note: The temperature may be limited by the specifications of the sensor.

Flow rate: 3 to 11 L/min

Note: The flow rate may be limited by the specifications of the sensor.

Pressure: Atmospheric pressure to 500 kPa

Note: The pressure may be limited by the specifications of the sensor.

Utility required for cleaning unit:

Type	Pressure (kPa)	Flow Rate
Water jet	200 to 400 + Liquid pressure	5 to 20 L/min
Water brush	100 to 250 + Liquid pressure	20 to 30 L/min
Air jet	200 to 400 + Liquid pressure	100 to 300 NL/min
Air brush	150 to 250 + Liquid pressure	300 to 600 NL/min

Note 1: Pressure and flow rate must be simultaneously satisfied at the holder inlet port.

Note 2: A large braid-reinforced tube of  $\phi 22 \times \phi 15$  is recommended for supply due to the flow rate.

### 3B. Flow-Through Type Holder (Explosionproof Type) PH8HFF

The holder is used only when using Ultrasonic cleaning system in the explosionproof area.

Use PH8HF when using no cleaning, jet cleaning or brush cleaning.

Applicable sensors:

General pH Sensor PH8ERP, PH8EFP

General ORP Sensor OR8ERG, OR8EFG

Mounting: 2-inch pipe mounting vertical or horizontal, with 1 set of mounting bracket.

Note: Make sure the mounting pipe is firmly installed.

Cleaning method: Ultrasonic cleaning

Material:

Holder; Polypropylene or stainless steel (316 SS)

O-ring; Fluoro rubber (FKM) or Perfluoroelastomer (FFKM)

Mounting bracket; Stainless steel (304 SS)

Cleaning unit (wetted parts):

Ultrasonic; Stainless steel (316 SS), titanium or Hastelloy C

Construction: TIIS flameproof type (for d2G4 gas)

Cable entrance port of terminal box; G 3/4

Weight:

Holder; Approx. 3 to 3.2 kg (polypropylene)  
Approx. 5.6 to 7.6 kg (stainless steel)

Mounting bracket; Approx. 0.5 kg

Temperature range: -5 to 80°C

Note: The temperature may be limited by the specifications of the sensor.

Flow rate: 3 to 11 L/min

Note: The flow rate may be limited by the specifications of the sensor.

Pressure: Atmospheric pressure to 500 kPa

Note: The pressure may be limited by the specifications of the sensor.

### 3C. Flow-Through Type Holder FH350G

Applicable sensors: MLSS Sensor SS300G  
(Measuring range: 0-1000 mg/L or less)

Note: Not applicable high range (greater than 0 to 1000mg/L) of MLSS sensor and DO sensor.

Mounting: 2-inch pipe mounting vertical or horizontal  
Note: Make sure the mounting pipe is firmly installed.

Cleaning method: Water or air jet cleaning  
(The wiper cleaning of MLSS cannot be used)

Material:

Holder; Polypropylene or stainless steel (316 SS)  
O-ring; Fluoro rubber (FKM)  
Mounting bracket; Stainless steel (304 SS)  
Cleaning unit (wetted parts); Polypropylene

Weight:

Holder; Approx. 0.4 to 5 kg  
Mounting bracket; Approx. 0.5 kg

Temperature range: 0 to 80°C

Note: The temperature may be limited by the specifications of the sensor.

Flow rate: 6 to 11 L/min

Note: Keep the specified flow rate to prevent substances from standing in the holder and bubbles from sticking onto the sensor.

Pressure: 0 to 200 kPa  
(Holder pressure rating is 500 kPa)

Utility required for cleaning unit:

Pressure:

Water jet; process pressure +100 to 200 kPa  
Air jet; process pressure +100 to 200 kPa

Flow Rate:

Water jet; 5 to 20 L/min  
Air jet; 10 to 20 NL/min

Note 1: Pressure and flow rate must be simultaneously satisfied at the holder inlet port.

Note 2: A large braid-reinforced tube of  $\phi 22 \times \phi 15$  is recommended for supply due to the flow rate.

### 4. Suspension Holder HH350G

Applicable sensor:

General pH Sensor; PH8ERP, PH8EFP  
General ORP Sensor; OR8ERG, OR8EFG  
Dissolved Oxygen Sensor; DO30G  
MLSS Sensor; SS300G

Note 1: When using a KCl filling type sensor, a stanchion or mounting bracket for the KCl tank is required separately.

Note 2: Not applicable for PH4/OR4 sensor.

Mounting: 2-inch pipe mounting vertical.

Note: Make sure the mounting pipe is firmly installed.

Cleaning method: Water or air jet cleaning Material:

Holder; Polypropylene and stainless steel (304 SS)  
Guide-pipe; Stainless steel (304 SS)  
Mounting bracket; Stainless steel (304 SS)  
Cleaning unit; Stainless steel (304 SS), PVC, and polypropylene

Weight: 6.4 to 13.8 kg

Temperature range: 0 to 80°C

Note: The temperature may be limited by the specifications of the sensor.

Flow rate: 1 m/s or less

Note: The flow speed may be limited by the specifications of the sensor.

Utility required for cleaning device:

Pressure; Water jet; 100 to 200 kPa  
Air jet; 100 to 200 kPa

Flow rate; Water jet; 5 to 20 L/min  
Air jet; 10 to 20 NL/min

Note 1: Pressure and flow rate must be simultaneously satisfied at the holder inlet port.

Note 2: A large braid-reinforced tube of  $\phi 22 \times \phi 15$  is recommended for supply due to the flow rate.

### 5. Angled Floating Ball Holder PB350G

Applicable sensors:

General pH Sensor; PH8ERP, PH8EFP  
General ORP Sensor; OR8ERG, OR8EFG  
Dissolved Oxygen Sensor; DO30G, DO70G  
MLSS Sensor; SS300G

Note 1: When using a KCl filling type sensor, a stanchion or mounting bracket for the KCl tank is required separately.

Note 2: Not applicable for PH4/OR4 sensor.

Pipe length: 2.5 m

Mounting: 2-inch pipe horizontal mounting or horizontal plane mounting

Note: Make sure the mounting pipe is firmly installed. Use anchor bolts(4xM8) or relevant fixtures for mounting on horizontal planes.

Material:

Holder; ABS resin, Nitrile rubber (NBR), brass, and PVC

Arm; PVC or stainless steel (304 SS)  
Mounting bracket; Stainless steel (304 SS)

Weight:

Holder (including arm);  
Approx. 5 kg (model PB350G-PV-25)  
Approx. 6 kg (model PB350G-S3-25)

Mounting bracket; Approx. 5 kg

Temperature range: 0 to 50°C

Note: The temperature may be limited by the specifications of the sensor.

Flow rate: 20 to 100 cm/s

(The arm must not be distorted significantly).

Note: The flow speed may be limited depending on the specifications of the sensor.

### 6. Vertical Floating Ball PB360G

Applicable sensors:

General pH Sensor; PH8ERP, PH8EFP  
General ORP Sensor; OR8ERG, OR8EFG  
Dissolved Oxygen Sensor; DO30G, DO70G  
MLSS Sensor; SS300G

Note 1: When using a KCl filling type sensor, a stanchion or mounting bracket for the KCl tank is required separately.

Note 2: Not applicable for PH4/OR4 sensor.

Mounting: 2-inch pipe vertical mounting

Note: Make sure the mounting pipe is firmly installed.

**Material:**

Holder;	ABS resin, brass, and rigid PVC
O-ring;	Nitrile rubber (NBR)
Arm;	rigid PVC or stainless steel (304 SS)
Guide-pipe;	Stainless steel (304 SS)
Mounting bracket;	Stainless steel (304 SS)
Roller, Pulley;	Polypropylene
Balance Weight;	Stainless steel (304 SS)
Rope;	Vinyl Covered Stainless steel (304 SS)
Connection Supporter;	Stainless steel (304 SS)

**Weight:**

Holder, guide-pipe, and arm;	
	Approx. 7.4 kg (model PB360G-PV-25-NN)
	Approx. 8.8 kg (model PB360G-PV-35-NN)
	Approx. 8.0 kg (model PB360G-S3-25-NN)
	Approx. 9.6 kg (model PB360G-S3-35-NN)

**Mounting bracket**

(including assist bracket and U-bolt assembly);  
Approx. 5 kg x 2 sets

**Roller assembly**

(including mounting bolt assembly);  
Approx. 3.3 kg x 2 sets

**Pulley assembly**

(including mounting bolt assembly);  
Approx. 0.5 kg

Connection supporter; Approx. 0.5 kg

**Balance weight;**

Approx. 3 kg (model PB360G-uu-25-NN)  
Approx. 4.5 kg (model PB360G-uu-35-NN)

**Rope (including bolt clip);**

Approx. 85 g (model PB360G-uu-25-NN)  
Approx. 97 g (model PB360G-uu-35-NN)

Temperature range: 0 to 50°C

Note: The temperature may be limited by the specifications of the sensor.

Flow rate: 20 to 100 cm/s

(The arm must not be distorted significantly).

Note: The flow speed may be limited depending on the specifications of the sensor.

**7A. Solenoid Valve for Jet/Brush Cleaning PH8MV**

Pilot kick operated, 2-port valve. Open when energized.

Fluid: Normal tap water, industrial water, or air

Operating pressure: 0 to 1 MPa

Forward (reverse) pressure resistance: 2 MPa

Fluid temperature:

Water; 5 to 60°C,  
Air; -10 to 60°C

Cv: 4.5

Process connection: Rc 1/2

Power supply: 100/110/200/220 V AC, 50/60 Hz

Power consumption: 10 W

Construction: IP53

Material:

Body; Bronze  
Sealing; Nitrile rubber

Ambient temperature: Maximum 50°C

Cable inlet connection: G 1/2

Weight: Approx. 0.9 kg

**7B. Explosionproof Type Solenoid Valve for Jet/Brush Cleaning PH8MVF**

Pilot kick operated, 2-port valve. Open when energized.

Fluid: Normal tap water, industrial water, or air

Operating pressure: 0.05 to 1 MPa

Forward (reverse) pressure resistance:  
1.5 MPa

Fluid temperature:

Water; 5 to 60°C

Air; -10 to 60°C

Cv: 4.5

Process connection: Rc 1/2

Power supply: 100 V AC, 50/60 Hz

110 V AC, 60 Hz

200 V AC, 50/60 Hz

220 V AC, 60 Hz

Power consumption: 10 W

Construction: IIIS flameproof type (for d2G4 gas)

Material:

Body; Bronze

Sealing; Nitrile rubber

Ambient temperature: Maximum 50°C

Leak at valve seat: 300 NmL/min

(air pressure: 50 to 700 kPa)

Cable inlet connection: Flameproof packin adaptor (G1/2)

Mounting position: Vertical mounting with coil in top

Weight: Approx. 1.9 kg

**8A. Ultrasonic Oscillator (Non-Explosionproof Type) PUS400G**

Combination device:

Holder with ultrasonic cleaner (PH8HS, PH8HF)

Connection cables are provided with holders.

Cleaning method:

Continuous ultrasonic emission (Frequency sweep method)

Oscillation frequency: Approx. 61 to 81 kHz

Output voltage: Approx. 70 V

Power supply: 100/110/115/200/220/240 V AC±10%  
50/60 Hz

Power consumption: Approx. 15 VA

Ambient Temperature: -10 to 50°C

(hood may be fitting as option)

Storage Temperature: -25 to 70°C

Construction: JIS C0920 Watertight

(NEMA 4 equivalent waterproof construction)

Material:

Case; Aluminum alloy casting

Window; Polycarbonate

Mounting bracket; Stainless steel

Finish: Baked polyurethane resin (Standard)  
Baked epoxy resin (Option)

Color:

Case; Frosty white  
(Munsell 2.5Y8.4/1.2 or equivalent)

Cover; Deep sea-moss green  
(Munsell 0.6GY3.1/2.0 equivalent)

Mounting: (2-inch) pipe mounting, wall or rack  
mounting or panel mounting

Cable inlet: ø22.7 x 2 Pg16 watertight plastic gland

Cable/Terminal: For 7 to 12 mm, M4

Conduit adaptor: Power Supply side only (Option)

Connection; G 1/2 or 1/2 NPT

**Weight:**

Body; Approx. 2.0 kg

Pipe mounting bracket; Approx. 0.7 kg

Wall mounting bracket; Approx. 0.4 kg

Note: Output of ultrasonic oscillator changes with power supply voltage or connected cable length.

Noise filter assembly: (only for PUS400G-NN-KC)

Ambient temperature; -10 to 50°C

(no dew condensation allowed)

Storage temperature; -25 to 70°C

Construction: JIS C 0920 Watertight (IP53)

**Regulatory Compliance:**

(for PUS400G-NN-KC)

Korea Electromagnetic Conformity Standard Class A

한국 전자파적합성 기준

RCM: EN55011 Class A Group 1

**8B1. Ultrasonic Oscillator (Explosionproof Type) PH8USF**

Combination device:

Holder with ultrasonic cleaner (PH8HSF, PH8HFF)

Note: This oscillator must be used with the Alarm Box PH8AL to provide power circuit interruption and failure alarm contact outputs.

Cleaning method: Continuous ultrasonic emission (Frequency sweep method)

Oscillation frequency: Approx. 65 to 80 kHz

Output voltage: Maximum 150 V

Power supply:

100, 110 to 115 (specify voltage), 200,

220 to 240 (specify voltage) V AC ±10%, 50/60 Hz

Power consumption: Approx. 15 VA

Construction: TIIIS flameproof construction (d2G4)

Material:

Case; Aluminum alloy

Finish: Baked polyurethane resin casting (optional)

Color:

Case; Munsell 7.5BG4/1.5 equivalent

Weight: Approx. 9.5 kg

Mounting: 2-inch pipe mounting

Ambient temperature: -10 to 50°C

Cable inlet: G 3/4

Cable/Terminal:

Oscillator to Vibrator;

3-conductor shielded cable, OD 10 to 12 mm,

Maximum length 10 m, Selectable by option code /C□□

Oscillator to Alarm box;

2-conductor shielded cable, OD 10 to 12 mm,

Maximum length 1000 m

Note: Total resistance of two leadwires should be 10 Ω or less. Complete grounding for explosionproof areas must be conducted

Note: Output of ultrasonic oscillator changes with power supply voltage or connected cable length.

**8B2. Alarm Box PH8AL**

Combination device:

One to one combination with ultrasonic Oscillator Explosionproof Type PH8USF

Case: Square shape, panel-back side mounting, dustproof steel plate construction, universal mounting position.

Coating color: Gray (Munsell N7.0)

Finish: Baked melamine resin

Power supply: 100, 110 to 115, 200, 220 to 240 V AC ±10%, 50/60 Hz

Note: Maximum voltage is 125 V AC when power supply of 110 to 115 V AC is specified, maximum voltage is 250 V AC when power supply of 220 to 240 V AC is specified.

Ambient temperature: -10 to 50°C

Weight: Approx. 2.0 kg

## ■ MODEL AND SUFFIX CODES

### 1. Guide Pipe PH8HG

Model	Suffix Code	Option Code	Description
<b>PH8HG</b>	.....	.....	Guide Pipe
Material	<b>-PV</b>	.....	Polyvinylchloride
	<b>-PP</b>	.....	Polypropylene
Style Code	<b>*A</b>	.....	Style A
Option	Mounting Bracket (*)	<b>/MS5</b>	Stainless steel mounting bracket (1 set)

\*: A set of 2-inch pipe mounting bracket is provided as standard.

### 2A.Submersion Type Holder PH8HS

Model	Suffix Code	Option Code	Description
<b>PH8HS</b>	.....	.....	Submersion type holder
Material	<b>-PP</b>	.....	Polypropylene
	<b>-S3</b>	.....	Stainless steel
	<b>-ST</b>	.....	Translucent polypropylene (*6)
Pipe length	<b>-10</b>	.....	1.0 m
	<b>-15</b>	.....	1.5 m
	<b>-20</b>	.....	2.0 m
	<b>-25</b>	.....	2.5 m
	<b>-30</b>	.....	3.0 m
pH Measuring System	<b>-T</b>	.....	Always -T
Cleaning Device	<b>-NN</b>	.....	No Cleaning
	<b>-S3</b>	.....	For ultrasonic cleaning (Transducer: 316 SS) (*1)
	<b>-TN</b>	.....	For ultrasonic cleaning (Transducer: Titanium) (*2)
	<b>-HC</b>	.....	For ultrasonic cleaning (Transducer: Hastelloy C) (*3)
	<b>-JT</b>	.....	For jet cleaning. The solenoid valve must be specified separately.
	<b>-BR</b>	.....	For brush cleaning. The solenoid valve must be specified separately.
Cable Length or Conne. Size	<b>-NN</b>	.....	No Cleaning
	<b>-C3</b>	.....	3 m
	<b>-C5</b>	.....	5 m
	<b>-C6</b>	.....	7 m
	<b>-C7</b>	.....	10 m
	<b>-C8</b>	.....	15 m
	<b>-C9</b>	.....	20 m
	<b>-JP</b>	.....	Rc1/2 (for Jet or Brush Cleaning)
	<b>-NP</b>	.....	1/2 NPT (for Jet or Brush Cleaning)
	Style Code	<b>*A</b>	.....
Option	Mounting (*5)	<b>/MS1</b>	Mounting bracket: 1 set
		<b>/MS2</b>	Mounting bracket: 2 sets
		<b>/MS3</b>	Stainless steel mounting bracket: 1 set
		<b>/MS4</b>	Stainless steel mounting bracket: 2 sets
		<b>/MS9</b>	Mounting hardware for calibration holder (*7)
	Special Mounting	<b>/F1</b>	JIS 10K 100 FF eq. Flange Mounting (Without Cleaner)
		<b>/F2</b>	JIS 10K 200 FF eq. Flange Mounting (With Cleaner)
O-ring	<b>/PF</b>	Perfluoroelastomer (FFKM) (*4)	

\*1: General purpose (Normal pH3 to 14)

\*2: For salt water

\*3: For acid (Normal pH0 to 4)

\*4: Choose Perfluoroelastomer (FFKM) when this holder is used in organic solvent, high alkali or high temperature alkali.

\*5: The required number of mounting bracket sets depends on the installation location and flow rate. In general, one set is sufficient for pipe lengths of 1 meter, and otherwise two sets are required.

\*6: For Pipe length, select -10, -15, -20.

\*7: For Material, select -ST.

## 2B.Submersion Type Holder (Explosionproof Type) PH8HSF

Model	Suffix Code	Option Code	Description
<b>PH8HSF</b>	.....	.....	Submersion type holder (Ex-proof type)
Material	<b>-PP</b> <b>-S3</b>	..... .....	Polypropylene Stainless steel
Pipe length	<b>-10</b> <b>-15</b> <b>-20</b>	..... ..... .....	1.0 m 1.5 m 2.0 m
Measuring System	<b>-T</b>	.....	Always -T
Cleaning Device (*4) (Ultrasonic cleaning only)	<b>-S3</b> <b>-TN</b> <b>-HC</b>	..... ..... .....	316SS Transducer (*1) Titanium Transducer (*2) Hastelloy C Transducer (*3)
Explosion Protection	<b>-JS</b>	.....	TIIS Flameproof (d2G4)
Style Code	<b>*A</b>	.....	Style A
Option	Mounting Bracket for Pipe  Flange Mounting Flameproof Packing Tag Plate O-ring	<b>/MS1</b> <b>/MS2</b> <b>/MS3</b> <b>/MS4</b> <b>/F</b> <b>/PG2</b> <b>/SCT</b> <b>/PF</b>	Mounting bracket: 1 set (*6) Mounting bracket: 2 sets (*6) Stainless steel mounting bracket: 1 set (*6) Stainless steel mounting bracket: 2 sets (*6) JIS 10K 200 FF equ. Flange Mounting Flameproof packing adapter 3/4 inch Stainless steel tag plate Perfluoroelastomer (FFKM) (*5)

\*1: General purpose (Normal pH3 to 14)

\*2: For salt water

\*3: For acid (Normal pH0 to 4)

\*4: Use PH8HS for no cleaning, Jet cleaning or brush cleaning.

\*5: Choose Perfluoroelastomer (FFKM) when this holder is used in organic solvent, high alkali or high temperature alkali.

\*6: The required number of mounting bracket sets depends on the installation location and flow rate. In general, one set is sufficient for pipe lengths of 1 meter, and otherwise two sets are required.

## 2C.Submersion Type Holder DOX8HS

Model	Suffix Code	Option Code	Description
<b>DOX8HS</b>	.....	.....	Submersion type holder
Material	<b>-PP</b> <b>-S3</b>	..... .....	Polypropylene Stainless steel
Pipe length	<b>-10</b> <b>-15</b> <b>-20</b> <b>-25</b> <b>-30</b> <b>-35</b> <b>-40</b>	..... ..... ..... ..... ..... ..... .....	1.0 m 1.5 m 2.0 m 2.5 m 3.0 m 3.5 m (stainless steel -S3 only) 4.0 m (stainless steel -S3 only)
Type	<b>-C</b> <b>-L</b>	..... .....	For DO30G, SS300G For DO70G
Cleaning Device (*1)	<b>-NN</b> <b>-JT</b>	..... .....	No Cleaning For jet cleaning (The solenoid valve must be specified separately.)
Connector for Cleaning	<b>-NN</b> <b>-JP</b> <b>-NP</b>	..... ..... .....	No Cleaning Rc1/2 1/2NPT
Style Code	<b>*B</b>	.....	Style B
Option	Mounting Bracket for Pipe (*2)	<b>/MS1</b> <b>/MS2</b> <b>/MS5</b> <b>/MS6</b>	Pipe mounting hardware: 1 set Pipe mounting hardware: 2 sets One mounting bracket (Stainless steel) Two mounting brackets (Stainless steel)

\*1: When using the wiper cleaning of MLSS meter, choose a proper cleaning system under the MS code of the MLSS sensor.

\*2: The required number of mounting bracket sets depends on the installation location and flow rate. In general, one set is sufficient for pipe lengths of 1 meter, and otherwise two sets are required.

## 3A.Flow-Through Type Holder PH8HF

[Style: S2]

Model	Suffix Code	Option Code	Description
PH8HF	.....	.....	Flow-through type holder
Material (*7)	-PP -S3 -PV -TN	..... ..... ..... .....	Polypropylene Stainless steel Heat-resistant PVC (*8) Titanium (*8)
Process Connection	-JPT -NPT -J10 -A15	..... ..... ..... .....	Rc1 1 NPT JIS 10K 25 FF (*6) ANSI Class 150 1 FF flange (only for -PP) (*6) ANSI Class 150 1 RF flange with serration (only for -S3)
Measuring System	-T	.....	Always -T
Cleaning Device	-NN -S3 -TN -HC -JT -BR	..... ..... ..... ..... ..... .....	No Cleaning For ultrasonic cleaning (Transducer: 316 SS) (*1) For ultrasonic cleaning (Transducer: Titanium) (*2) For ultrasonic cleaning (Transducer: Hastelloy C) (*3) For jet cleaning. The solenoid valve must be specified separately. For brush cleaning. The solenoid valve must be specified separately.
Cable length or Connection	-NN -C1 -C3 -C6 -C7 -C8 -C9 -JP -NP	..... ..... ..... ..... ..... ..... ..... ..... .....	None 1 m 3 m 7 m 10 m 15 m 20 m Rc1/2 (for Jet or Brush Cleaning) 1/2 NPT (for Jet or Brush Cleaning)
Style Code	*A	.....	Style A
Option	Mounting Bracket for Pipe O-ring	/MF1 /PF /TF1 /TF2	Stainless Steel Mounting Bracket (*5) Perfluoroelastomer (FFKM) (*4) Fluororesin coated O-ring for PH8ECP (*9) Fluororesin coated O-ring for PH4C and PH4CT (*9)

\*1: General purpose (Normal pH 3 to 14)

\*2: For salt water

\*3: For acid (Normal pH 0 to 4)

\*4: Choose Perfluoroelastomer (FFKM) when this holder is used in organic solvent, high alkali or high temperature alkali.

\*5: Mounting bracket is generally not required when the stainless steel holder is installed in-line in a pipe. It is required where the holder is installed in a sampling rack (in which case the U-bolt included in /MF1 is not used).

\*6: Only mating dimensions are according to flange standard.

\*7: Criteria for material selection (-PP or -S3)

In general, polypropylene is recommended from the viewpoint of chemical resistance.

However stainless steel is recommended in any of the following cases:

- The liquid contains organic reagent, oxidizing agents, etc., which can attack polypropylene.
- The temperature/pressure correlation of the process condition falls within the hatched area of the diagram shown right.
- The use of polypropylene is not reasonable from a viewpoint of strength or past experience.

For stainless steel, normally a 3 to 14 pH value is recommended.

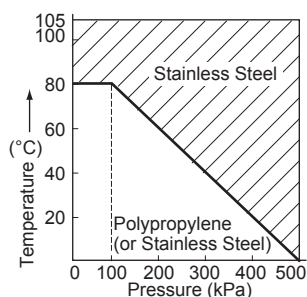

\*8: For Process Connection, select -J10 or -A15, for Cleaning Device select -NN.

\*9: Selectable only when Material is -PV or -TN.

### 3B.Flow-Through Type Holder (Explosionproof Type) PH8HFF

[Style: S2]

Model	Suffix Code	Option Code	Description
PH8HFF	.....	.....	Flow-through type holder (Ex-proof type)
Material (*7)	-PP -S3	..... .....	Polypropylene (Refer to note below for selection) Stainless steel
Process Connection	-JPT -NPT -J10 -A15	..... ..... ..... .....	Rc1 1 NPT female thread JIS 10K 25 FF flange ANSI Class 150 1 FF flange equivalent (for polypropylene holder -PP) ANSI Class 150 1 RF Flange with serration (for 316 SS holder -S3)
Measuring System	-T	.....	Always -T
Cleaning Device (*4) (Ultrasonic cleaning only)	-S3 -TN -HC	..... ..... .....	316SS transducer (*1) Titanium transducer (*2) Hastelloy C transducer (*3)
Explosion Protection	-JS	.....	TIIS Flameproof (d2G4)
Style Code	*A	.....	Style A
Option	Mounting Bracket for Pipe Flameproof Packing Tag Plate O-ring	/MF1 /PG2 /SCT /PF	Stainless Steel Mounting Bracket (*6) JIS flameproof packing adapter 3/4 inch Stainless steel tag plate Perfluoroelastomer (FFKM) (*5)

\*1: General purpose (Normal pH 3 to 14)

\*2: For salt water

\*3: For acid (Normal pH 0 to 4)

\*4: Use PH8HS for no cleaning, Jet cleaning or Brush cleaning.

\*5: Choose Perfluoroelastomer (FFKM) when this holder is used in organic solvent, high alkali or high temperature alkali.

\*6: Mounting bracket is generally not required when the stainless steel holder is installed in-line in a pipe  
It is required where the holder is installed in a sampling rack (in which case the U-bolt included in /MF1 is not used).

\*7: Criteria for material selection (-PP or -S3)

In general, polypropylene is recommended from the viewpoint of chemical resistance.

However stainless steel is recommend in any of the following cases:

- The liquid contains organic reagent, oxidizing agents, etc., which can attack polypropylene.
- The temperature/pressure correlation of the process condition falls within the hatched area of the diagram shown right.
- The use of polypropylene is not reasonable from a viewpoint of strength or past experience.

For stainless steel, normally a 3 to 14 pH value is recommended.

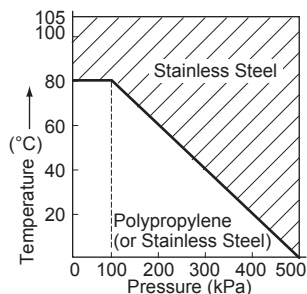

### 3C.Flow Type Holder FH350G (For MLSS Meter)

Model	Suffix Code	Option Code	Description
FH350G	.....	.....	Flow type holder
Material	-PP -S3	..... .....	Polypropylene Stainless steel
Process Connection	-JPT1 -NPT1 -J10F -A15F -A15R	..... ..... ..... ..... .....	Rc1 1 NPT female JIS 10K 25 FF flange ANSI Class 150 1 FF flange equivalent (Only -PP) ANSI Class 150 1 RF flange with serration (Only -S3)
Cleaning Device	-NN -JT	..... .....	Not Required For Jet Cleaning (A solenoid valve is separately required)
Connection for Jet Cleaning	-NN -JP -NP	..... ..... .....	Not Required Rc 1/2 1/2 NPT female thread
Option	Mounting Hardware Tag Plate	/MF5 /SCT	Stainless Steel Mounting Bracket Stainless steel tag plate

Note: Required flow rate is 6 L/min or greater.

Maximum measuring range of MLSS sensor is 0 to 1000 mg/L.

#### 4. Pull-up Type Holder HH350G

Model	Suffix Code	Option Code	Description
<b>HH350G</b>	.....	.....	Pull-up Type Holder
-	<b>-NN</b>	.....	Always -NN
Guide Pipe Length	<b>-00</b> <b>-10</b> <b>-20</b> <b>-30</b> <b>-40</b>	..... ..... ..... ..... .....	Not required 1 m 2 m 3 m 4 m
Cleaning Device	<b>-NN</b> <b>-JT</b>	..... .....	No Cleaning For jet cleaning (The solenoid valve must be specified separately.)
Connection for Jet Cleaning	<b>-NN</b> <b>-JP</b> <b>-NP</b>	..... ..... .....	Not required Rc 1/2 1/2 NPT

#### 5. Slant Type Float Holder PB350G

Model	Suffix Code	Option Code	Description
<b>PB350G</b>	.....	.....	Slant Type Float Holder
Arm Material	<b>-PV</b> <b>-S3</b>	..... .....	PVC Stainless steel
Pipe Length	<b>-00</b> <b>-25</b>	..... .....	Not required (Only -PV) (*1) 2.5 m
-	<b>-NN</b>	.....	Always -NN

\*1: When pipe (JIS K6741 VP40) is prepared by user.

#### 6. Vertical Type Float Holder PB360G

Model	Suffix Code	Option Code	Description
<b>PB360G</b>	.....	.....	Vertical Type Float Holder
Arm Material	<b>-PV</b> <b>-S3</b>	..... .....	PVC Stainless steel
Pipe Length	<b>-25</b> <b>-35</b>	..... .....	2.5 m 3.5 m
Float Type	<b>-NN</b>	.....	Standard Type

#### 7A. Solenoid Valve for Jet/Brush Cleaning PH8MV

Model	Suffix Code	Option Code	Description
<b>PH8MV</b>	.....	.....	Solenoid Valve for Jet/Brush Cleaning
Fluid	<b>-A</b> <b>-W</b>	..... .....	Air Water
Power Supply	<b>-100</b> <b>-110</b> <b>-200</b> <b>-220</b>	..... ..... ..... .....	100 V AC 110 V AC 200 V AC 220 V AC
Power Frequency	<b>-50</b> <b>-60</b>	..... .....	50 Hz 60 Hz
Style Code	<b>*D</b>	.....	Style D

### 7B.Solenoid Valve (Explosionproof Type) for Jet/Brush Cleaning PH8MVF

Model	Suffix Code	Option Code	Description
<b>PH8MVF</b>	.....	.....	Flameproof type Solenoid Valve
Fluid Name	<b>-A</b> <b>-W</b>	..... .....	Air Water
Power Supply	<b>-100</b> <b>-110</b> <b>-200</b> <b>-220</b>	..... ..... ..... .....	100 V AC 50/60 Hz 110 V AC 60 Hz only 200 V AC 50/60 Hz 220 V AC 60 Hz only
Frequency	<b>-50</b> <b>-60</b>	..... .....	50 Hz 60 Hz
Explosion Protection	<b>-JS</b>	.....	TIIS Flameproof (d2G4)
Style Code	<b>*B</b>	.....	Style B
Option	Tag Plate	<b>/SCT</b>	Stainless steel tag plate

### 8A.Ultrasonic Oscillator PUS400G

Model	Suffix Code	Option Code	Description
<b>PUS400G</b>	.....	.....	Ultrasonic Oscillator (for pH Meter)
-	<b>-NN</b>	.....	Always -NN
Application	<b>-NN</b> <b>-KC</b>	..... .....	General purpose General purpose for Korea and Australia
Power Supply	<b>-1</b> <b>-2</b> <b>-3</b> <b>-4</b> <b>-5</b> <b>-6</b>	..... ..... ..... ..... ..... .....	100 V AC 50/60 Hz 110 V AC 50/60 Hz 115 V AC 50/60 Hz 200 V AC 50/60 Hz 220 V AC 50/60 Hz 240 V AC 50/60 Hz
Language Used for Cautions	<b>-E</b> <b>-J</b>	..... .....	English Japanese
Option	Mounting Bracket  Hood  Special Coating Tag Plate Conduit Adaptor	<b>/PS</b> <b>/W</b> <b>/PA</b> <b>/H</b> <b>/H2</b> <b>/X1</b> <b>/SCT</b> <b>/AFTG</b> <b>/ANSI</b> <b>/SPS</b>	Pipe mounting bracket (stainless steel) Wall mounting bracket (stainless steel) Panel mounting bracket (stainless steel) Awning hood (carbon steel) Awning hood (stainless steel) Epoxy coating Stainless steel tag plate G1/2 1/2 NPT Teflon coated stainless steel screws

### 8B1. Ultrasonic Oscillator (Explosionproof Type) PH8USF

Model	Suffix Code	Option Code	Description
<b>PH8USF</b>	.....	.....	Explosionproof type Ultrasonic Oscillator
Power Supply	<b>-3</b> <b>-4</b> <b>-5</b> <b>-7</b>	..... ..... ..... .....	200 V AC 50/60 Hz 220 to 240 V AC 50/60 Hz specify voltage 100 V AC 50/60 Hz 110 to 115V AC 50/60 Hz specify voltage
Explosion Protection	<b>-JS</b>	.....	TIIS Flameproof (d2G4)
Style Code	<b>*A</b>	.....	Style A
Option	Mounting Bracket Oscillator - Holder Cable  Gasket Tag Plate	<b>/PM</b> <b>/C□□</b>  <b>/PG2</b> <b>/SCT</b>	2-inch pipe mounting Specify the length in meter □□. No termination e.g. /C03 refers to the cable length of 3 m. Standard cable lengths: 3, 7, 10 m, 10 m max. TIIS flameproof packing adaptor 3/4 inch: 2 pcs Stainless steel tag plate

Note: PH8USF must be used with Alarm Box PH8AL.

For 110 to 115 V AC or 220 to 240 V AC power supplies, specify the voltage when ordering.

Tolerance is  $\pm 10\%$  of the voltage specified.

Example: Power supply voltage 110 V AC

8B2. Alarm Box PH8AL

Model	Suffix Code	Option Code	Description
PH8AL	.....	.....	Alarm box
Power Supply	-3	.....	200 V AC 50/60 Hz
	-4	.....	220 to 240 V AC 50 to 60 Hz
	-5	.....	100 V AC 50/60 Hz
	-7	.....	110 to 115 V AC 50 to 60 Hz
Style Code	*A	.....	Style A
Option		/APC	Air purge connector Rc1/4

■ WIRING DIAGRAM

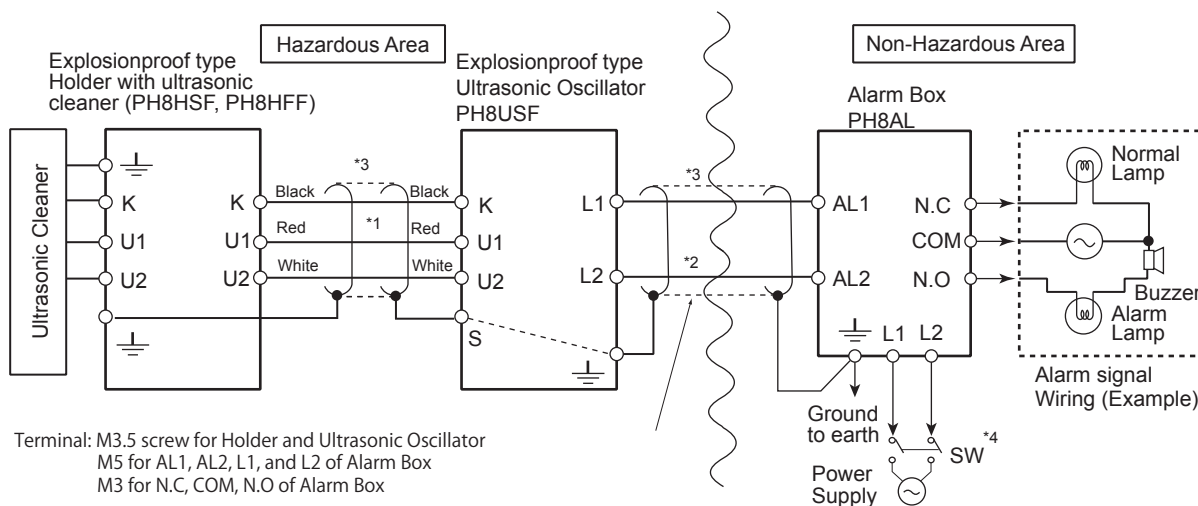

- \*1: 3-conductor cable of OD 10 to 12 mm. Max. 10 m (e.g. CVV 1.25 mm<sup>2</sup> x 3c)
- \*2: 2-conductor shielded cable of OD 10 to 12 mm, Max. 1000 m.  
Normal conductor cross-section: 3.5 mm<sup>2</sup> or greater. (total lead resistance not to exceed 10 Ω)
- \*3: Metal conduit or flexible conduit (only with flameproof packing)
- \*4: Must prepare a switch for power supply in a panel.

Wiring for Non-Explosionproof Ultrasonic Cleaning System

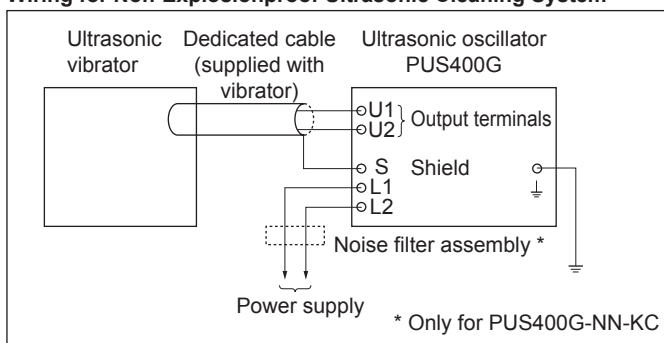

F002.ai

**■ DIMENSIONS**

**Guide Pipe (with Mounting Bracket)**  
PH8HG

UNIT : mm

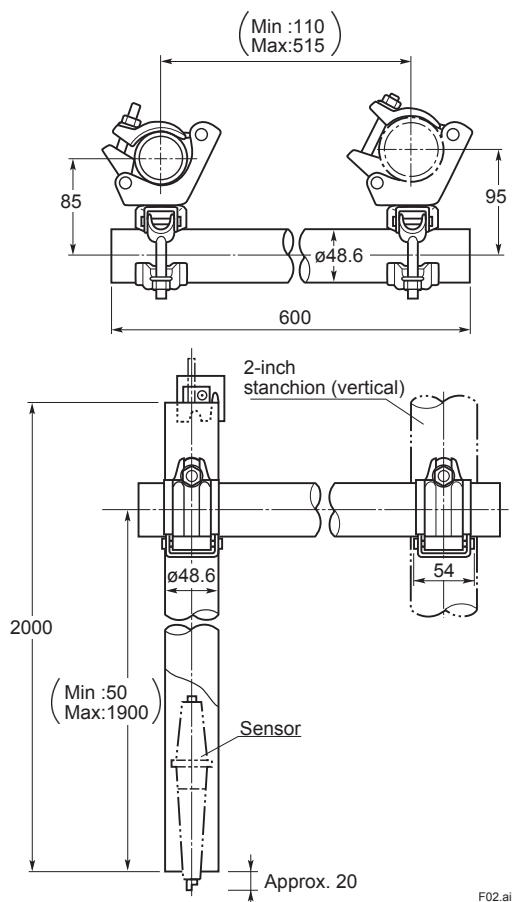

- **Mounting Bracket, Stainless Steel**  
/MS5 (1 set), /MS6 (2 set)

UNIT : mm

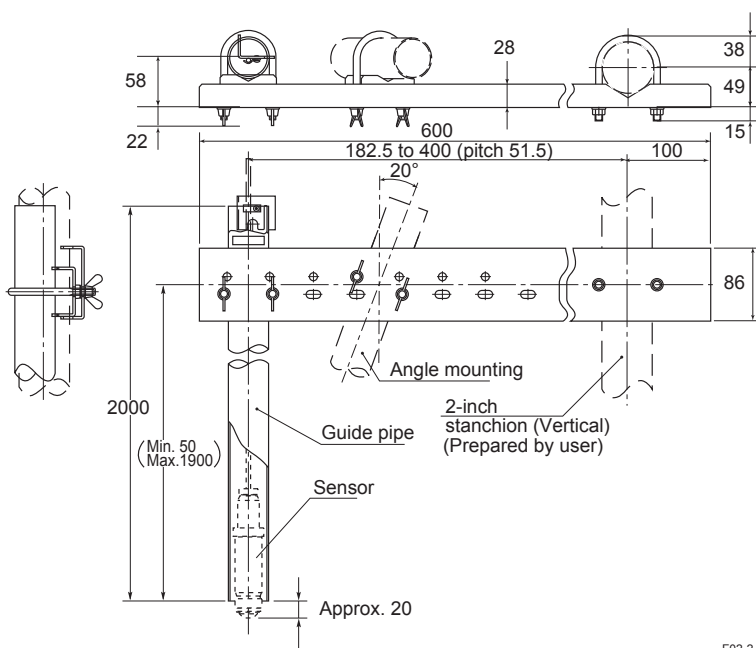

**Submersion Type Holder, Polypropylene,  
PH8HS-PP, PH8HS-ST**

UNIT : mm

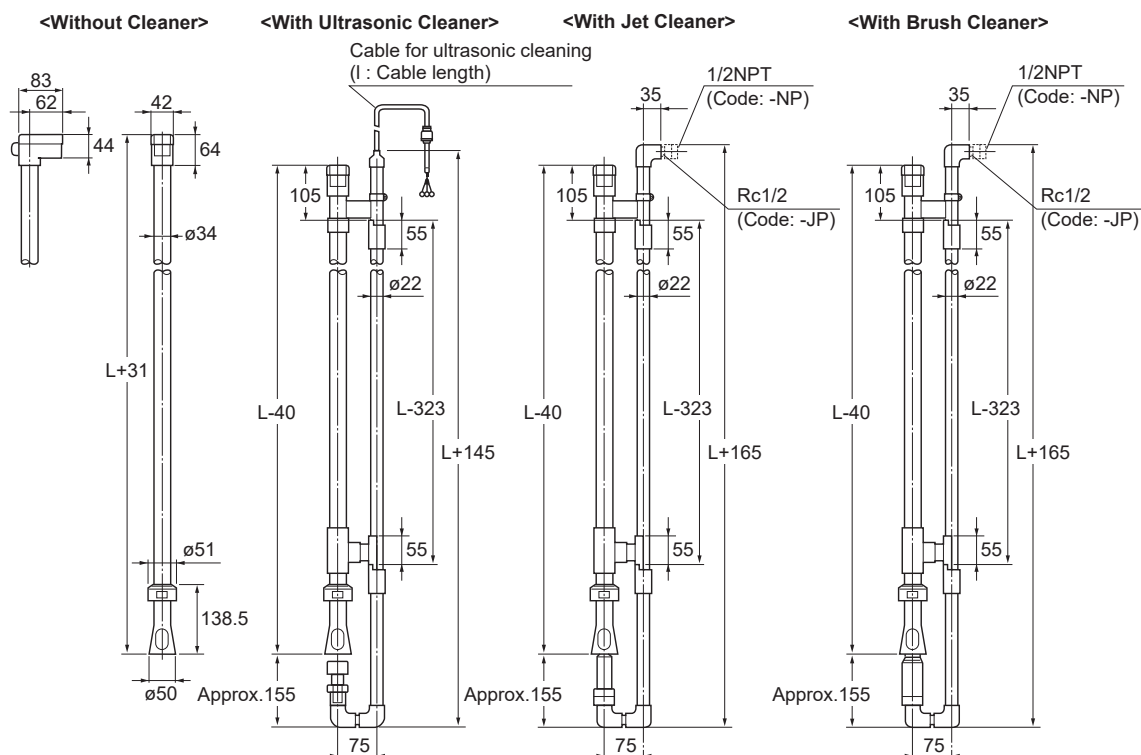

Specification of Holder (Model and Code)	Cable Length (l) (Code : C□)	Weight (Approx.) (Top or Left: Material - PP, Bottom or Right: Material - ST)				
		Nominal Holder Length (L)				
		1000mm [Code : -10]	1500mm [Code : -15]	2000mm [Code : -20]	2500mm [Code : -25]	3000mm [Code : -30]
Without Cleaner PH8HS-PP-□□-T-NN-NN PH8HS-ST-□□-T-NN-NN	—	0.5 kg 0.5 kg	0.65 kg 0.65 kg	0.8 kg 0.8 kg	1.0 kg —	1.1 kg —
With Ultrasonic Cleaner PH8HS-PP-□□-T-S3-C□ PH8HS-PP-□□-T-TN-C□ PH8HS-PP-□□-T-HC-C□ PH8HS-ST-□□-T-S3-C□ PH8HS-ST-□□-T-TN-C□ PH8HS-ST-□□-T-HC-C□	3m (C3) 5m (C5) 7m (C6) 10m (C7) 15m (C8) 20m (C9)	1.7 kg 0.8 kg 1.8 kg 0.8 kg 1.9 kg 0.9 kg 2.1 kg 1.1 kg 2.5 kg 1.5 kg 2.9 kg 1.9 kg	2.2 kg 1.0 kg 2.3 kg 1.0 kg 2.4 kg 1.1 kg 2.6 kg 1.3 kg 3.0 kg 1.7 kg 3.4 kg 2.1 kg	2.7 kg 1.2 kg 2.8 kg 1.2 kg 2.9 kg 1.3 kg 3.1 kg 1.5 kg 3.5 kg 1.9 kg 3.9 kg 2.3 kg	3.2 kg 3.3 kg 3.4 kg 3.6 kg 4.0 kg 4.4 kg	3.7 kg 3.8 kg 3.9 kg 4.1 kg 4.5 kg 4.9 kg
With Jet Cleaner PH8HS-PP-□□-T-JT-□□ PH8HS-ST-□□-T-JT-□□	—	1.6 kg 0.7 kg	2.1 kg 0.9 kg	2.6 kg 1.1 kg	3.1 kg —	3.6 kg —
With Brush Cleaner PH8HS-PP-□□-T-BR-□□ PH8HS-ST-□□-T-BR-□□	—	1.6 kg 0.7 kg	2.1 kg 0.9 kg	2.6 kg 1.1kg	3.1 kg —	3.6 kg —

F03.ai

## Submersion Type Holder, Stainless Steel

PH8HS-S3

UNIT : mm

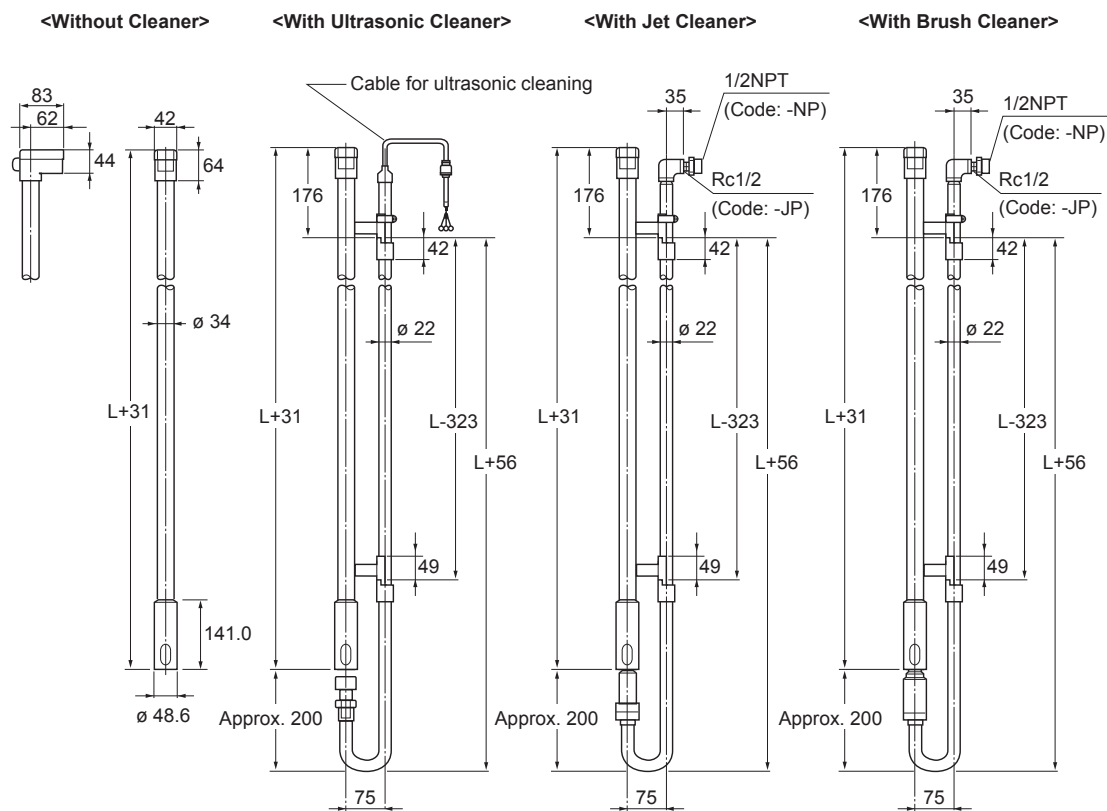

Specification of Holder (Model and Code)	Weight (Approx.)				
	Nominal Holder Length (L)				
	1000mm [Code : -10]	1500mm [Code : -15]	2000mm [Code : -20]	2500mm [Code : -25]	3000mm [Code : -30]
Without Cleaner PH8HS-S3-□□-T-NN	1.5 kg	2.3 kg	3.1 kg	3.9 kg	4.7 kg
With Non-Explosionproof Ultrasonic Cleaner PH8HS-S3-□□-T-S3, TN, HC	2.7 kg	3.9 kg	5.1 kg	6.3 kg	7.5 kg
With Jet Cleaner PH8HS-S3-□□-T-JT	2.5 kg	3.6 kg	4.7 kg	5.8 kg	6.9 kg
With Brush Cleaner PH8HS-S3-□□-T-BR	2.5 kg	3.6 kg	4.7 kg	5.8 kg	6.9 kg

F07.ai

**Submersion Type Holder (Explosionproof Type), Polypropylene**  
PH8HSF-PP

UNIT : mm

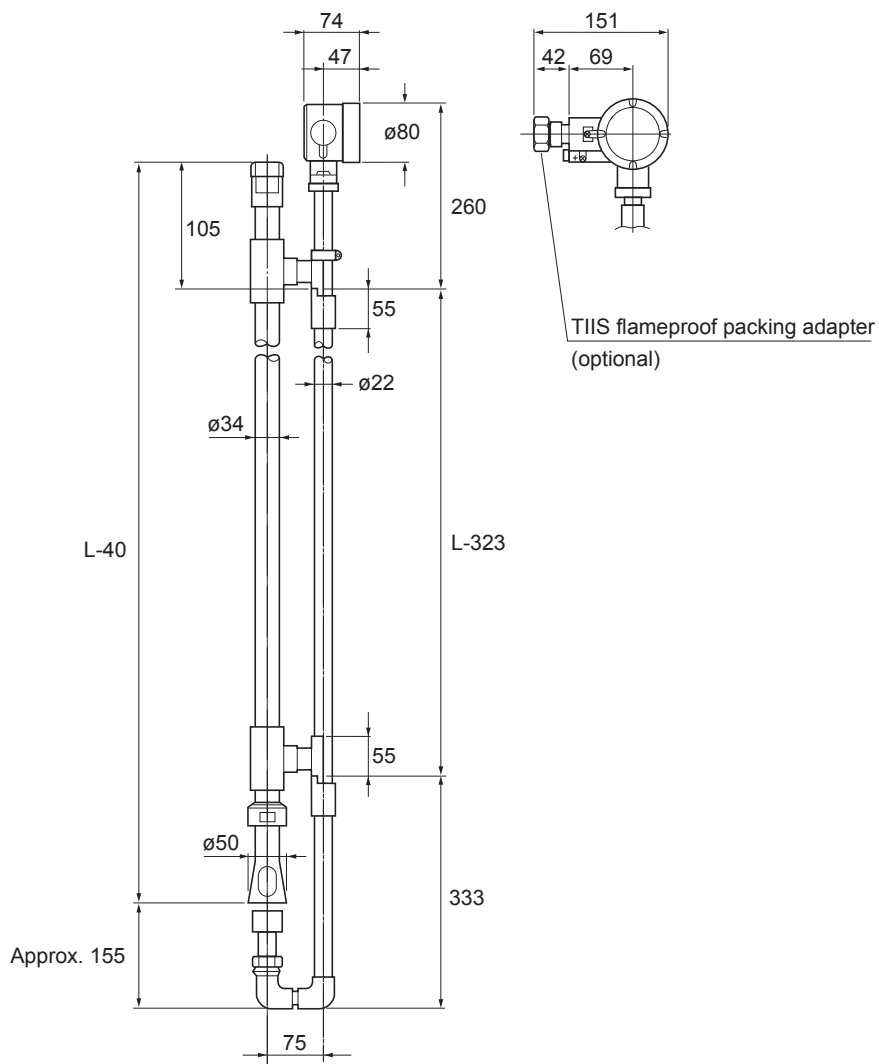

Specification of Holder (Model and Code)	Weight (Approx.)		
	Nominal Holder Length (L)		
	1000mm [Code: -10]	1500mm [Code: -15]	2000mm [Code: -20]
With Ultrasonic Cleaner PH8HSF-PP-□□-T-S3, TN, HC	2.2 kg	2.7 kg	3.2 kg

F11.ai

**Submersion Type Holder (Explosionproof Type), Stainless Steel**  
PH8HSF-S3

UNIT : mm

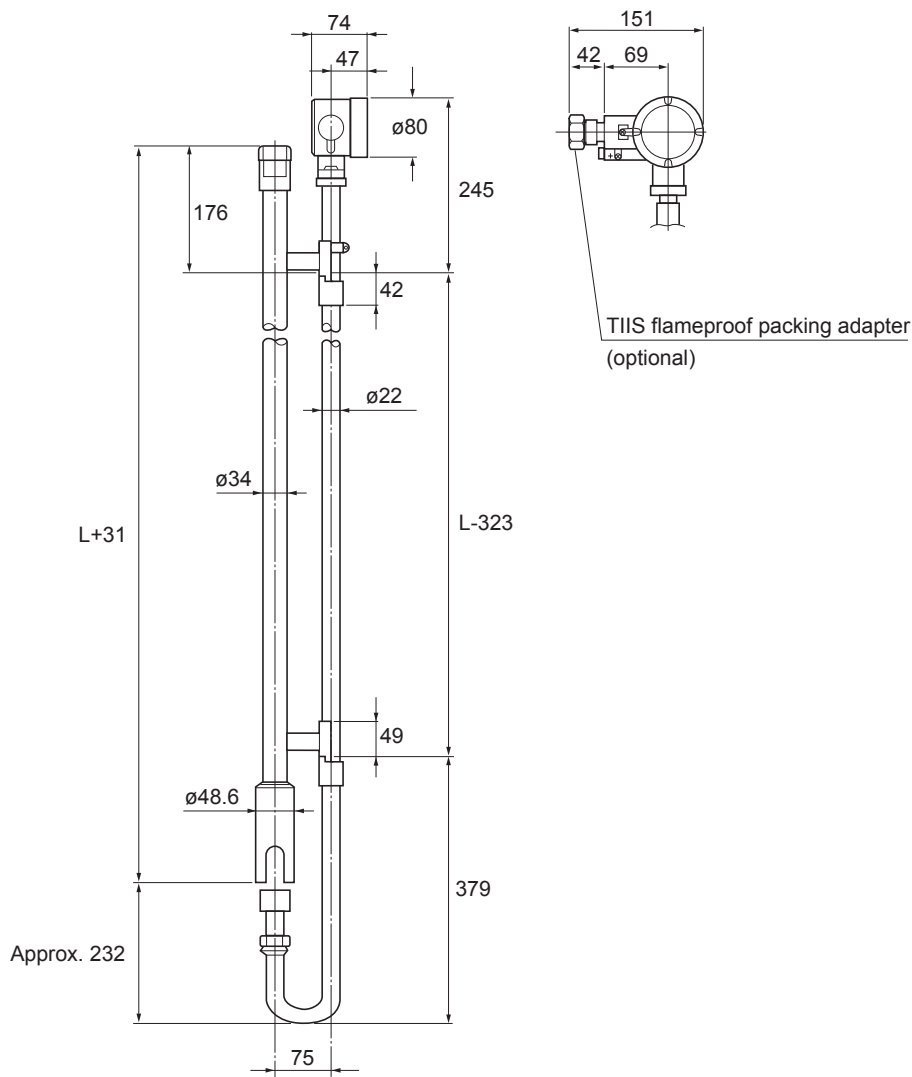

L = Normal holder length (Standard: 1000 mm, 1500 mm, 2000 mm)

Specification of Holder (Model and Code)	Weight (Approx.)		
	Nominal Holder Length (L)		
	1000mm [Code : -10]	1500mm [Code : -15]	2000mm [Code : -20]
With Flameproof Ultrasonic Cleaner PH8HSF-S3-□□-T-S3, TN, HC	3.3 kg	4.5 kg	5.7 kg

F15.ai

• **Mounting Bracket for Submersion Type Holder**

/MS1: 1 set, /MS2: 2 set

<For Holder without cleaner>

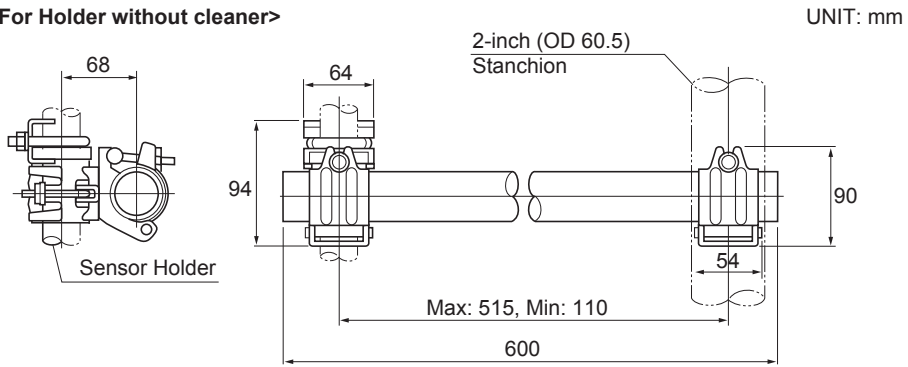

<For Holder with Cleaner>

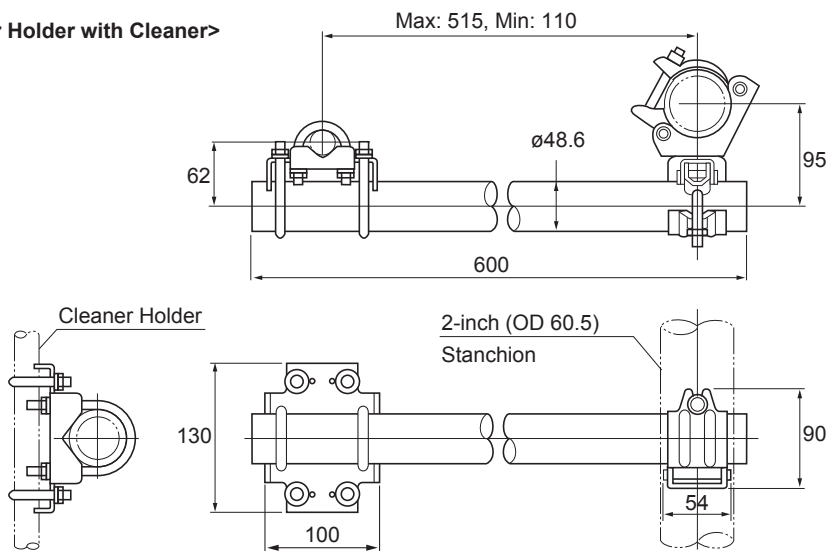

F08.ai  
Weight: Approx. 1kg

• **Stainless Steel Mounting Bracket for Submersion Type Holder**

/MS3: 1 set, /MS4: 2 sets

UNIT : mm

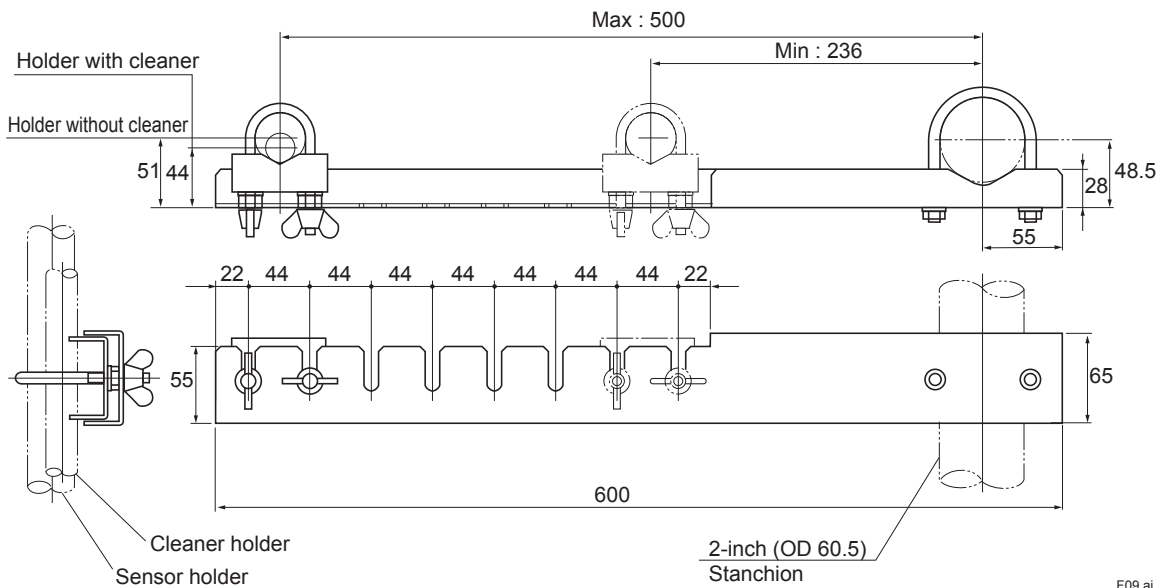

F09.ai  
Weight: Approx. 1kg

• **Mounting Hardware for Calibration Holder (/MS9)**  
 PH8HS-ST-...../MS9

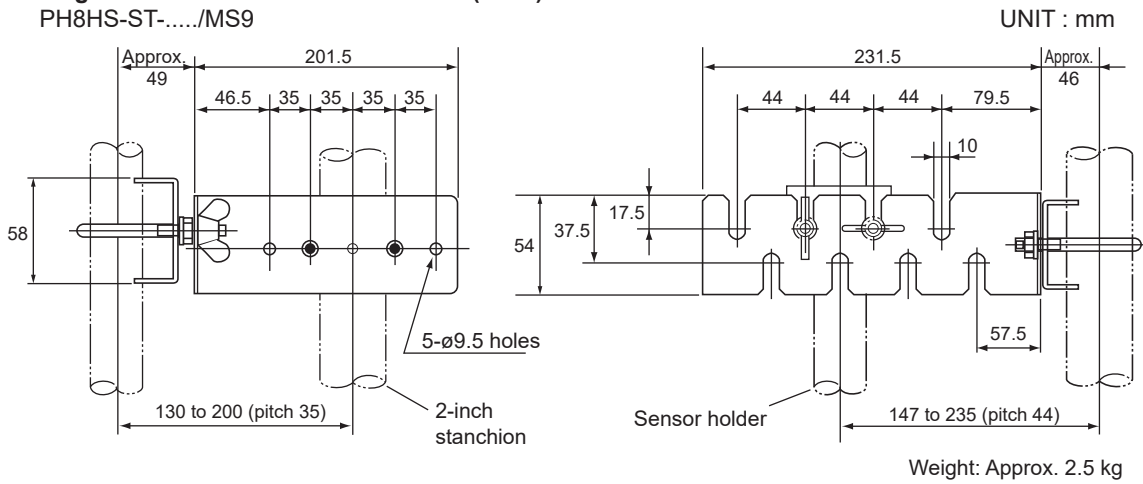

• /F□ Flange Mounting

UNIT : mm

/F1: Flange of holder without cleaner  
 - Material: Polypropylene  
 Translucent polypropylene -

/F2: Flange of holder with cleaner, or /F  
 - Material: Polypropylene  
 Translucent polypropylene -

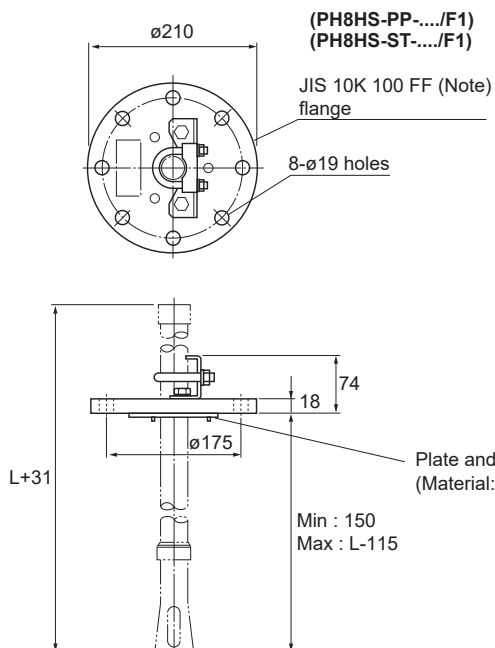

Flange weight: Approx. 1 kg

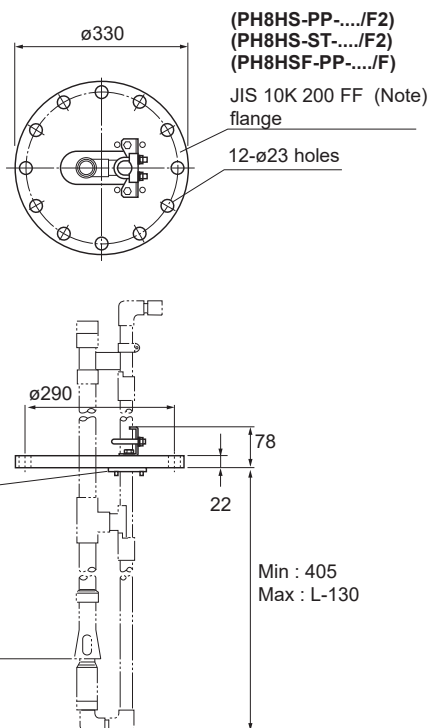

Flange weight: Approx. 1.5 kg

F06.ai

/F1: Flange of holder without cleaner  
 - Material: Stainless steel (316 SS) -

/F2: Flange of holder with cleaner  
 - Material: Stainless steel (316 SS) -

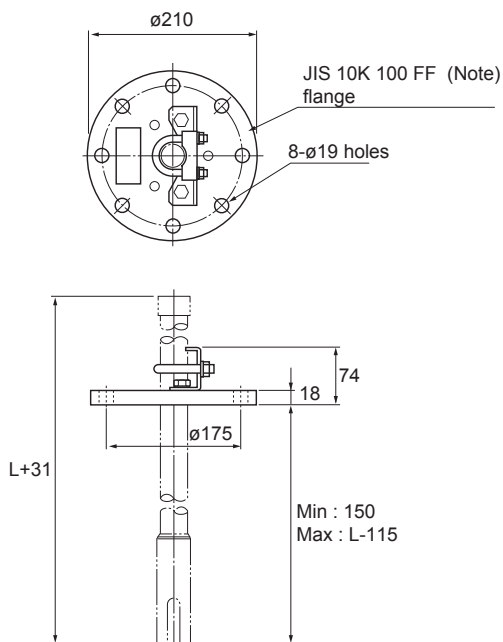

Flange weight: Approx. 5 kg

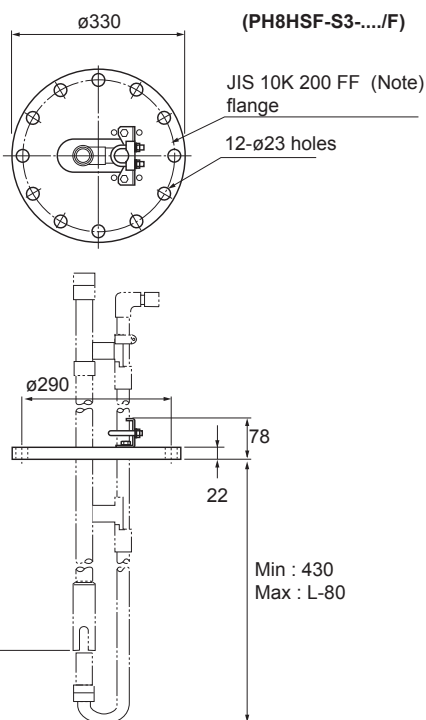

Flange weight: Approx. 15 kg

F10.ai

**Submersion Type Holder, Polypropylene (See separate drawing for mounting bracket)**  
 DOX8HS-PP (For DO30G and SS300G)

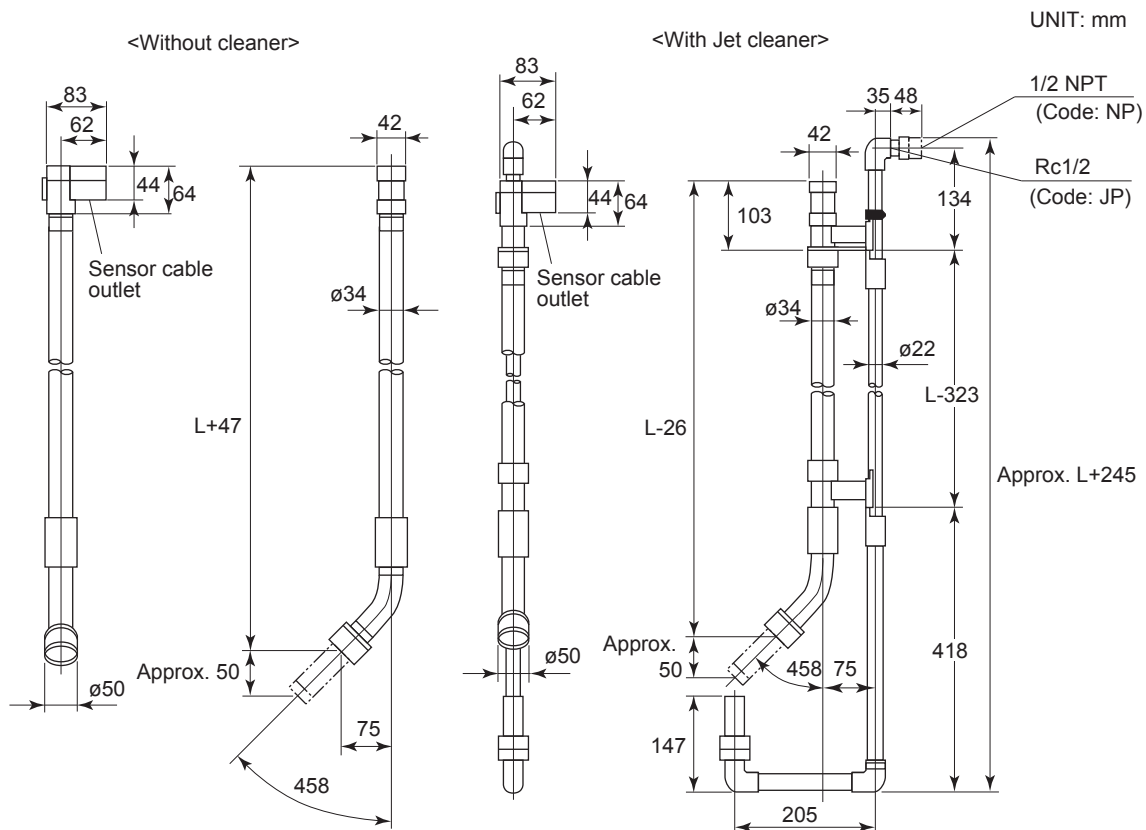

Specification of Holder (Model and Code)	Weight (Approx.)				
	Nominal Holder Length (L)				
	1000 mm [ Code: -10 ]	1500 mm [ Code: -15 ]	2000 mm [ Code: -20 ]	2500 mm [ Code: -25 ]	3000 mm [ Code: -30 ]
Without Cleaner DOX8HS-PP-□□-C-NN-NN*B/□□	Approx. 0.5 kg	Approx. 0.65 kg	Approx. 0.8 kg	Approx. 0.95 kg	Approx. 1.1 kg
With Jet cleaner DOX8HS-PP-□□-C-JT-□P*B/□□	Approx. 1.6 kg	Approx. 2.1 kg	Approx. 2.6 kg	Approx. 3.1 kg	Approx. 3.6 kg

F19.ai

**Submersion Type Holder, Polypropylene (See separate drawing for mounting bracket)**  
 DOX8HS-PP (For DO70G)

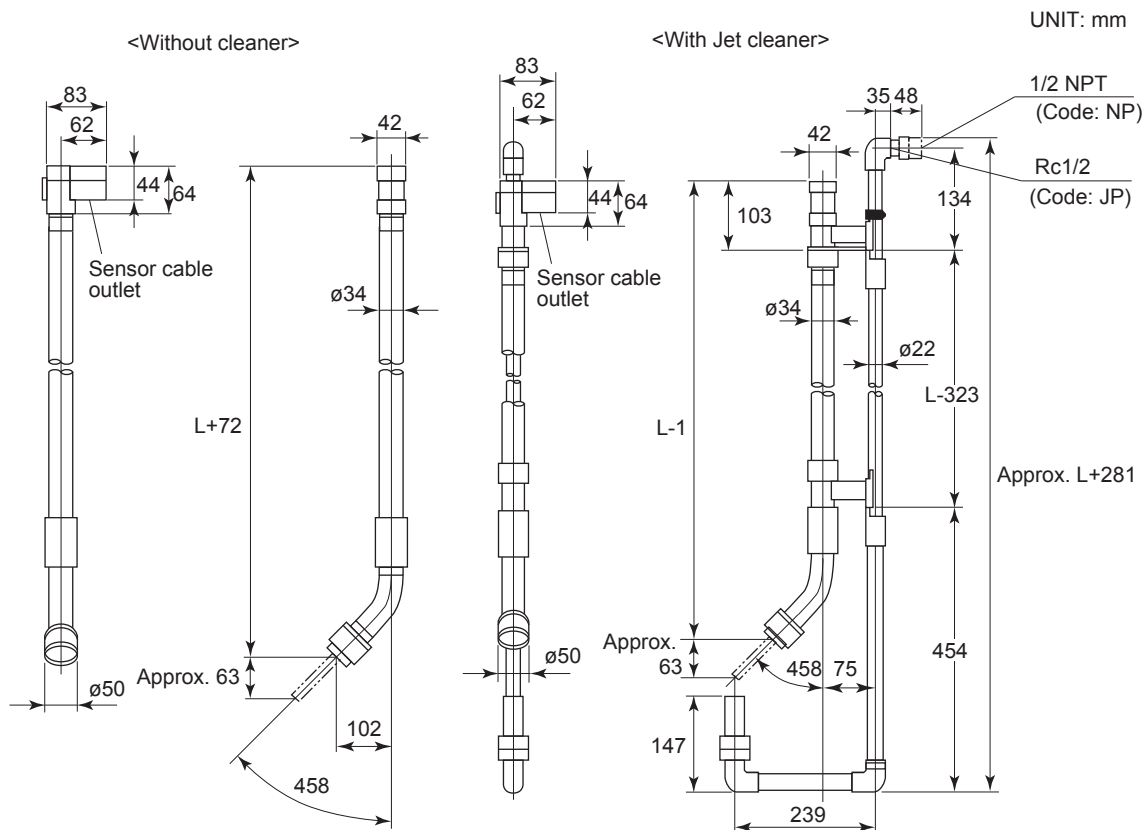

Specification of Holder (Model and Code)	Weight (Approx.)				
	Nominal Holder Length (L)				
	1000 mm [ Code: -10 ]	1500 mm [ Code: -15 ]	2000 mm [ Code: -20 ]	2500 mm [ Code: -25 ]	3000 mm [ Code: -30 ]
Without Cleaner DOX8HS-PP-□□-L-NN-NN*B/□□	Approx. 0.5 kg	Approx. 0.65 kg	Approx. 0.8 kg	Approx. 0.95 kg	Approx. 1.1 kg
With Jet cleaner DOX8HS-PP-□□-L-JT-□P*B/□□	Approx. 1.7 kg	Approx. 2.2 kg	Approx. 2.7 kg	Approx. 3.2 kg	Approx. 3.7 kg

F19-1.ai

**Submersion Type Holder, Stainless Steel (See separate drawing for mounting bracket)**  
DOX8HS-S3 (For DO30G and SS300G)

UNIT: mm

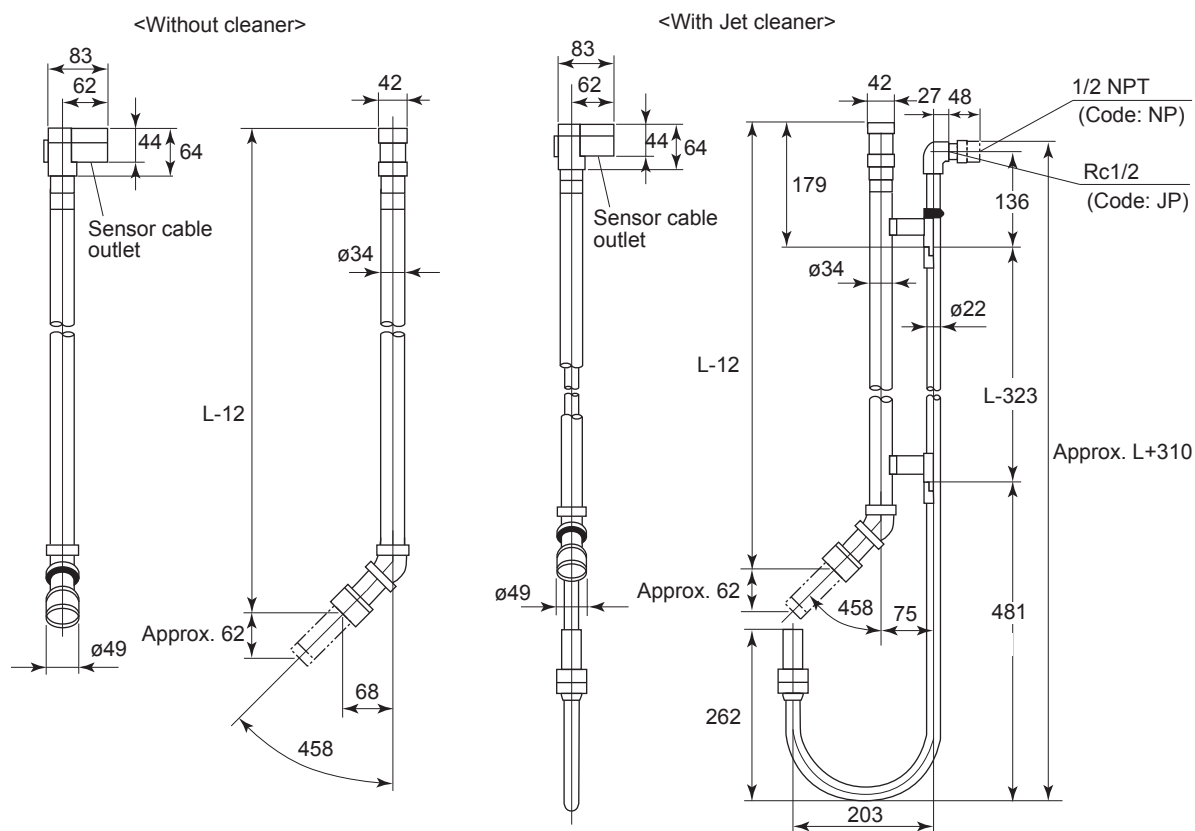

Specification of Holder (Model and Code)	Weight (Approx.)				
	Nominal Holder Length (L)				
	1000 mm [ Code:-10 ]	1500 mm [ Code:-15 ]	2000 mm [ Code:-20 ]	2500 mm [ Code:-25 ]	3000 mm [ Code:-30 ]
Without Cleaner DOX8HS-S3-□□-C-NN-NN*B/□□	1.9 kg	3.1 kg	4.3 kg	5.5 kg	6.7 kg
With Jet cleaner DOX8HS-S3-□□-C-JT-□P*B/□□	4.1 kg	5.6 kg	7.1 kg	8.6 kg	10.1 kg

Specification of Holder (Model and Code)	Weight (Approx.)	
	Nominal Holder Length (L)	
	3500 mm [ Code:-35 ]	4000 mm [ Code:-40 ]
Without Cleaner DOX8HS-S3-□□-C-NN-NN*B/□□	7.9 kg	9.1 kg
With Jet cleaner DOX8HS-S3-□□-C-JT-□P*B/□□	11.6 kg	13.1 kg

F20.ai

For the "/MS1", "/MS2" Mounting Bracket, see page 20, for the "/MS5", "/MS6", see page 15.

**Submersion Type Holder, Stainless Steel (See separate drawing for mounting bracket)**  
 DOX8HS-S3 (For DO70G)

UNIT: mm

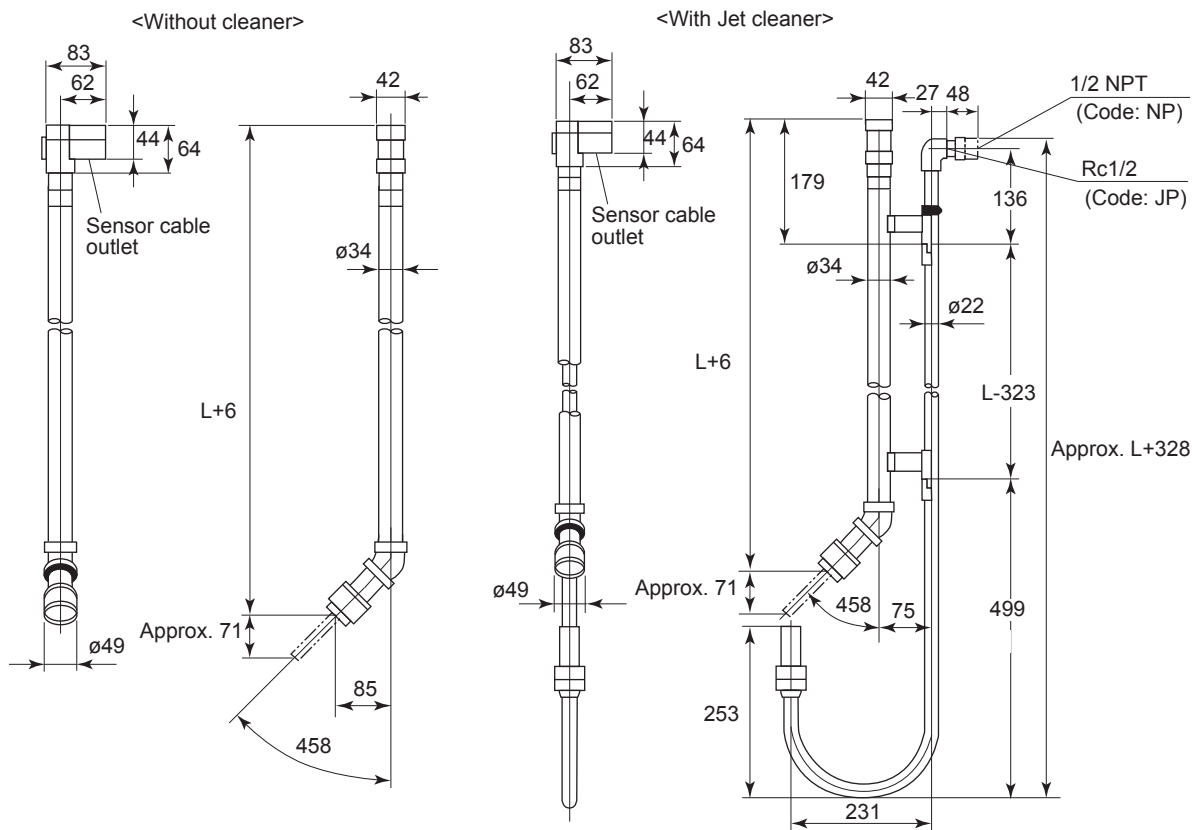

Specification of Holder (Model and Code)	Weight (Approx.)				
	Nominal Holder Length (L)				
	1000 mm [ Code:-10 ]	1500 mm [ Code:-15 ]	2000 mm [ Code:-20 ]	2500 mm [ Code:-25 ]	3000 mm [ Code:-30 ]
Without Cleaner DOX8HS-S3-□□-L-NN-NN*B/□□	2.0 kg	3.2 kg	4.4 kg	5.6 kg	6.8 kg
With Jet cleaner DOX8HS-S3-□□-L-JT-□P*B/□□	4.2 kg	5.7 kg	7.2 kg	8.7 kg	10.2 kg

Specification of Holder (Model and Code)	Weight (Approx.)	
	Nominal Holder Length (L)	
	3500 mm [ Code:-35 ]	4000 mm [ Code:-40 ]
Without Cleaner DOX8HS-S3-□□-L-NN-NN*B/□□	8.0 kg	9.2 kg
With Jet cleaner DOX8HS-S3-□□-L-JT-□P*B/□□	11.7 kg	13.2 kg

F20-1.ai

For the "/MS1", "/MS2" Mounting Bracket, see page 20, for the "/MS5", "/MS6", see page 15.

**Flow-Through Type Holder**

PH8HF-PP-□PT-T-NN-NN

PH8HF-S3-□PT-T-NN-NN

UNIT : mm

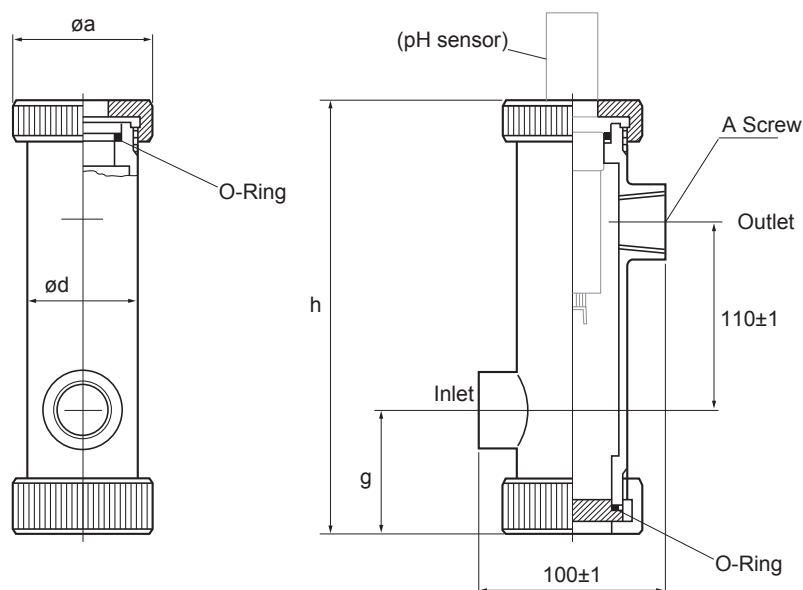

Model and Code	A Screw	a	d	g	h	Weight
PH8HF-PP-JPT-T-NN-NN	Rc1	80	Approx. 60	Approx. 70	Approx. 250	Approx. 0.4kg
PH8HF-PP-NPT-T-NN-NN	1NPT	80	Approx. 60	Approx. 70	Approx. 250	Approx. 0.4kg
PH8HF-S3-JPT-T-NN-NN	Rc1	70	Approx. 60	Approx. 70	Approx. 243	Approx. 3kg
PH8HF-S3-NPT-T-NN-NN	1NPT	70	Approx. 60	Approx. 70	Approx. 243	Approx. 3kg

F23.ai

**Flow-Through Type Holder**

PH8HF-PP-□1□-T-NN-NN

PH8HF-S3-□1□-T-NN-NN

UNIT : mm

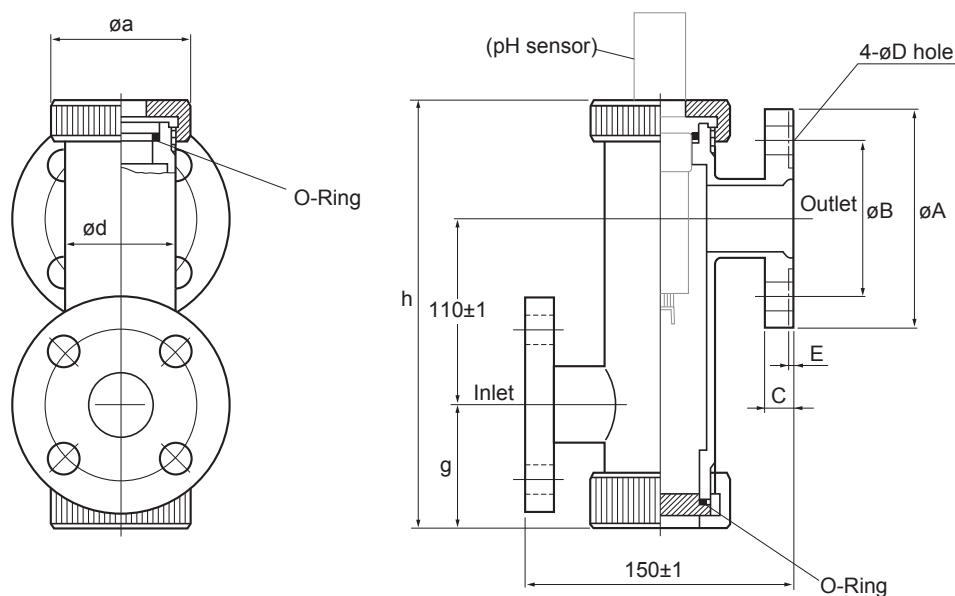

Model and Code	A	B	C	D	E	a	d	g	h	Weight
PH8HF-PP-J10-T-NN-NN	125	90	14	19	-	80	Approx. 60	Approx. 70	Approx. 250	Approx. 0.6kg
PH8HF-PP-A15-T-NN-NN	108	79.4	14.2	15.7	-	80	Approx. 60	Approx. 70	Approx. 250	Approx. 0.6kg
PH8HF-S3-J10-T-NN-NN	125	90	14	19	-	70	Approx. 60	Approx. 70	Approx. 243	Approx. 5kg
PH8HF-S3-A15-T-NN-NN	108	79.2	14.2	15.7	2	70	Approx. 60	Approx. 70	Approx. 243	Approx. 5kg

F24.ai

**Flow-Through Type Holder**

PH8HF-PV-□1□-T-NN-NN

UNIT : mm

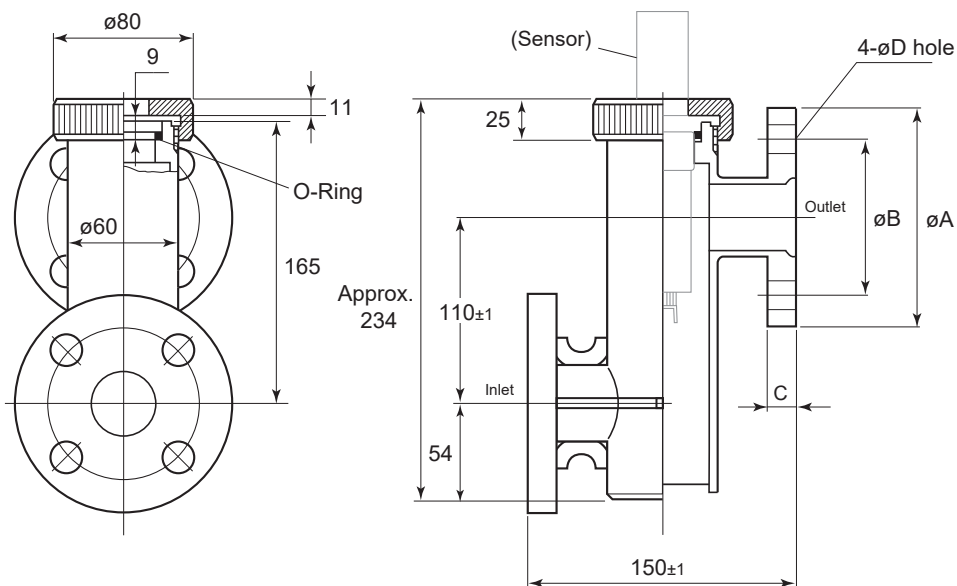

Model and Code	A	B	C	D	Weight
PH8HF-PV-J10-T-NN-NN	125	90	14	19	Approx. 0.7 kg
PH8HF-PV-A15-T-NN-NN	108	79.2	14.2	15.7	Approx. 0.7 kg

**Flow-Through Type Holder**

PH8HF-TN-□1□-T-NN-NN

UNIT : mm

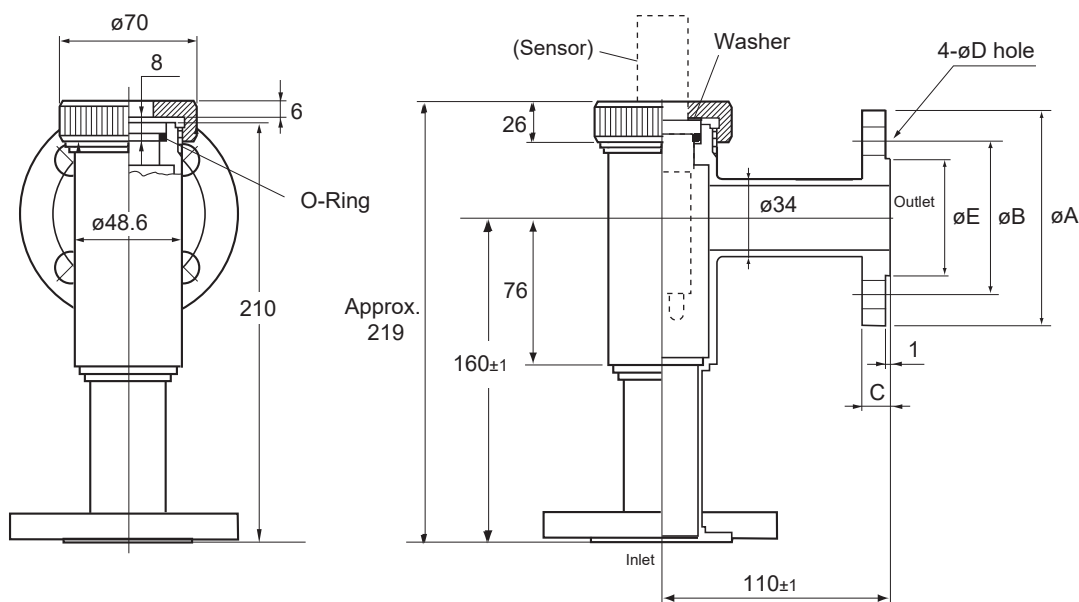

Model and Code	A	B	C	D	E	Weight
PH8HF-TN-J10-T-NN-NN	125	90	14	19	68.5	Approx. 3.2kg
PH8HF-TN-A15-T-NN-NN	108	79.2	14.2	15.7	57.5*	Approx. 3.2kg

\*: With serrations F30.ai

**Flow-Through Type Holder, Screw Connection, With Jet Cleaner / Brush Cleaner**  
 PH8HF-□□-□PT-T-□□-□P

UNIT : mm

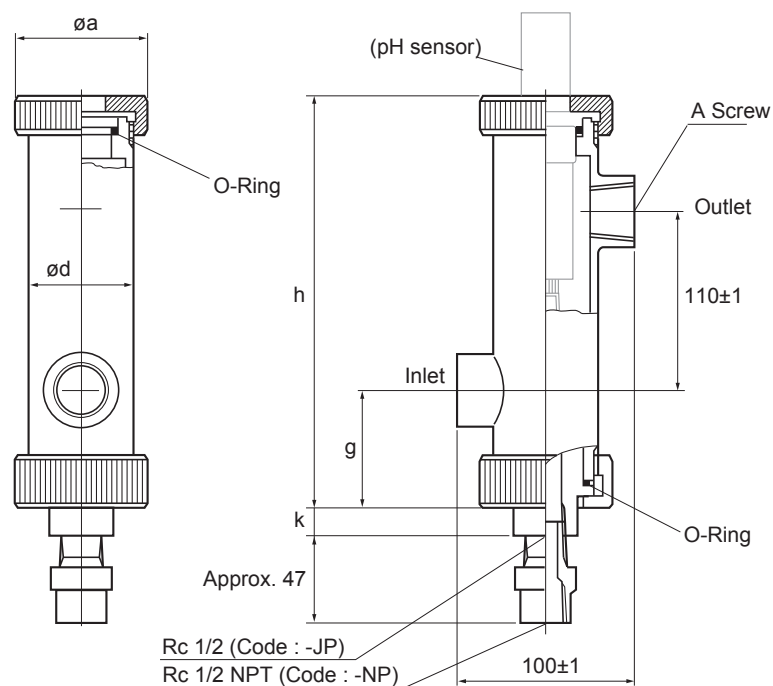

Model and Code	A Screw	a	d	g	h	k	Weight
PH8HF-PP-JPT-T-□□-□P	Rc1	80	Approx. 60	Approx. 70	Approx. 250	15	Approx. 1.4kg
PH8HF-S3-JPT-T-□□-□P	Rc1	70	Approx. 60	Approx. 70	Approx. 245	17	Approx. 4kg
PH8HF-PP-NPT-T-□□-□P	1NPT	80	Approx. 60	Approx. 70	Approx. 250	15	Approx. 1.4kg
PH8HF-S3-NPT-T-□□-□P	1NPT	70	Approx. 60	Approx. 70	Approx. 245	17	Approx. 4kg

F25.ai

**Flow-Through Type Holder, Flange Connector With Jet Cleaner / Brush Cleaner**

PH8HF-□□-□1□-T-□□-□P

UNIT : mm

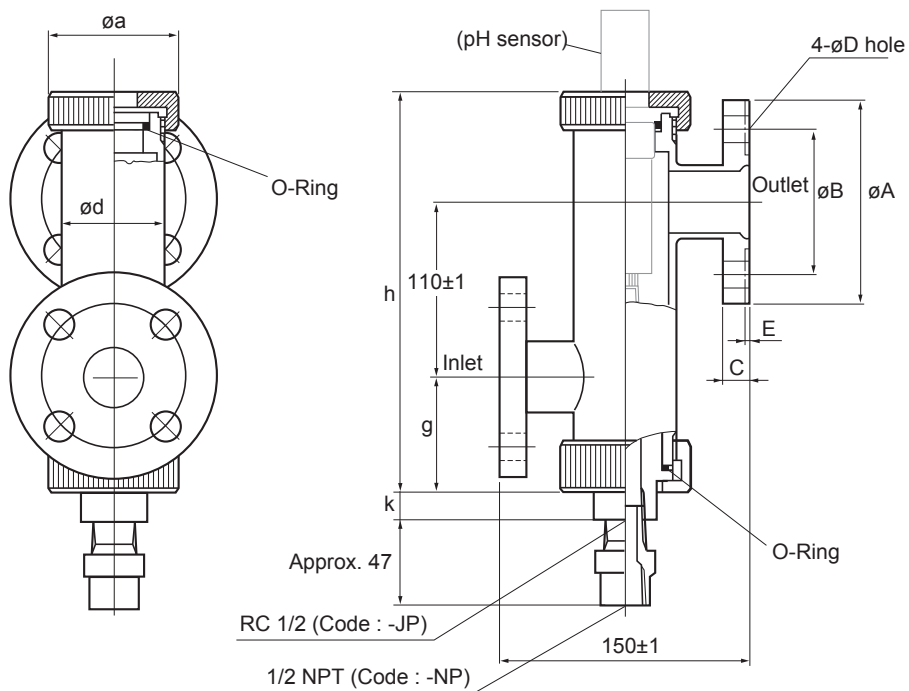

Model and Code	A	B	C	D	E	a	d	g	h	k	Weight
PH8HF-PP-J10-T-□□-□P	125	90	14	19	-	80	Approx. 60	Approx. 70	Approx. 250	15	Approx. 1.6kg
PH8HF-S3-J10-T-□□-□P	125	90	14	19	-	70	Approx. 60	Approx. 70	Approx. 245	17	Approx. 6kg
PH8HF-PP-A15-T-□□-□P	108	79.4	14.2	15.7	-	80	Approx. 60	Approx. 70	Approx. 250	15	Approx. 1.6kg
PH8HF-S3-A15-T-□□-□P	108	79.2	14.2	15.7	2	70	Approx. 60	Approx. 70	Approx. 245	17	Approx. 6kg

F26.ai

**Flow-Through Type Holder, Screw Connection, With Ultrasonic Cleaner**

PH8HF-□□-□PT-T-□□-C□

UNIT : mm

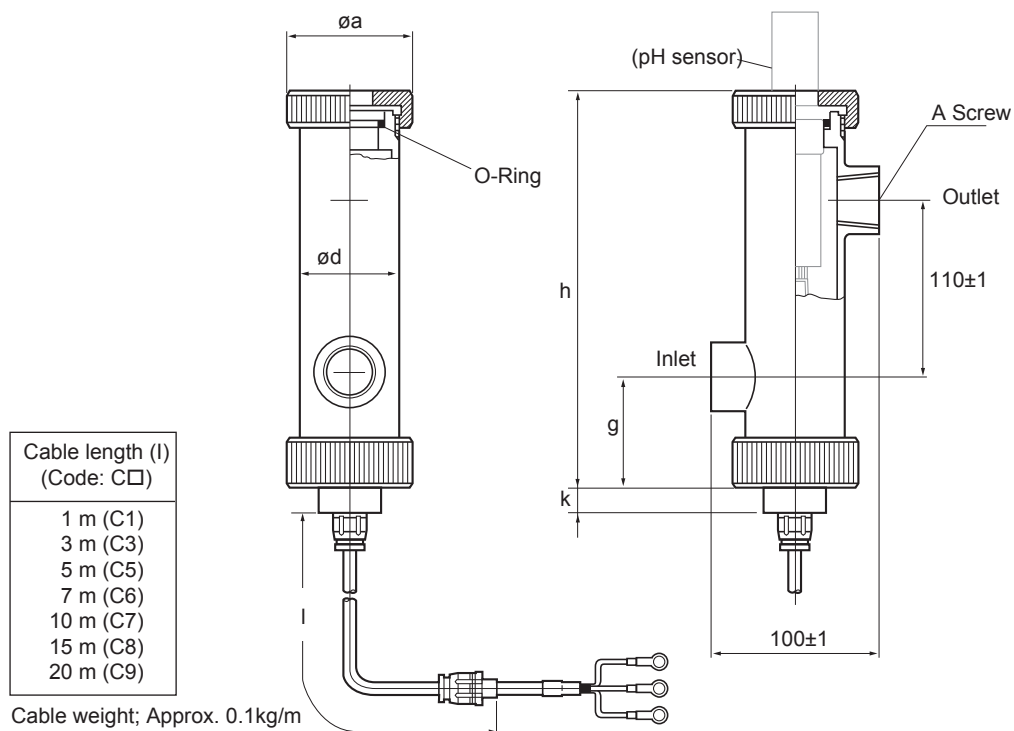

Mode and Code	A Screw	a	d	g	h	k	Weight
PH8HF-PP-JPT-T-□□-C□	Rc1	80	Approx. 60	Approx. 70	Approx. 250	15	Approx. 1.5kg
PH8HF-S3-JPT-T-□□-C□	Rc1	70	Approx. 60	Approx. 70	Approx. 245	17	Approx. 4.1kg
PH8HF-PP-NPT-T-□□-C□	1NPT	80	Approx. 60	Approx. 70	Approx. 250	15	Approx. 1.5kg
PH8HF-S3-NPT-T-□□-C□	1NPT	70	Approx. 60	Approx. 70	Approx. 245	17	Approx. 4.1kg

F27.ai

**Flow-Through Type Holder, Flange Connection, With Ultrasonic Cleaner**

PH8HF-□□-□1□-T-□□-C□

UNIT : mm

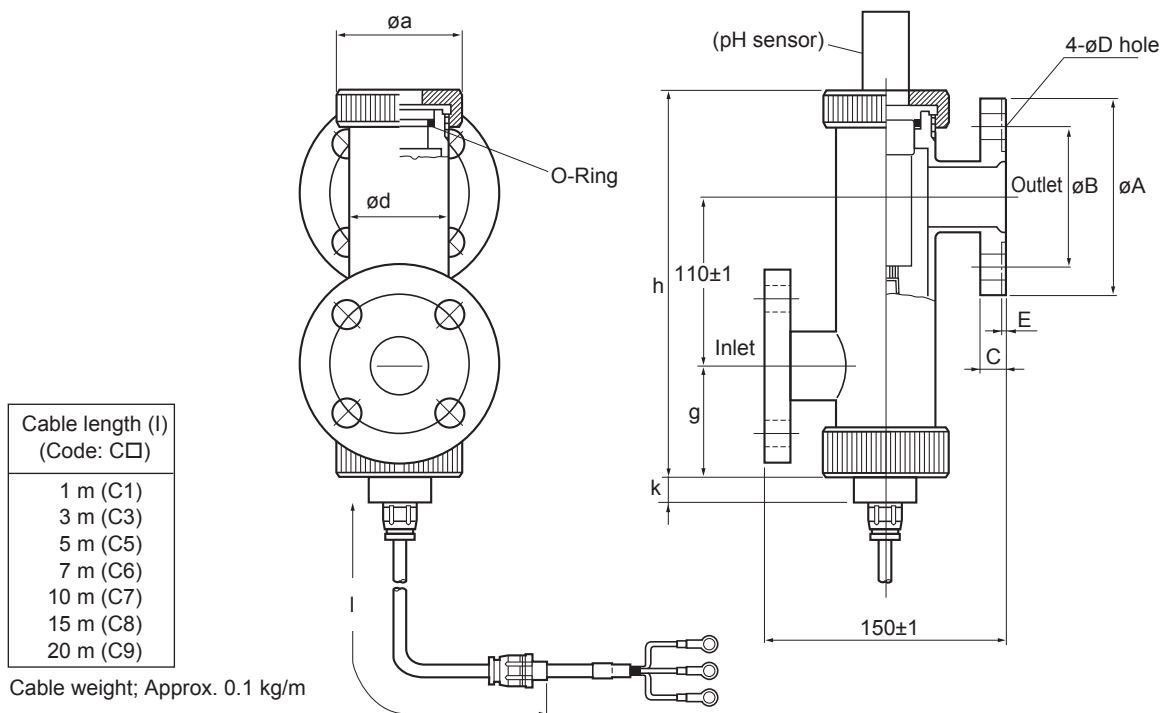

Cable length (l) (Code: C□)
1 m (C1)
3 m (C3)
5 m (C5)
7 m (C6)
10 m (C7)
15 m (C8)
20 m (C9)

Cable weight; Approx. 0.1 kg/m

Model and Code	A	B	C	D	E	a	d	g	h	k	Weight
PH8HF-PP-J10-T-□□-C□	125	90	14	19	-	80	Approx. 60	Approx. 70	Approx. 250	15	Approx. 1.7kg
PH8HF-S3-J10-T-□□-C□	125	90	14	19	-	70	Approx. 60	Approx. 70	Approx. 245	17	Approx. 6.1kg
PH8HF-PP-A15-T-□□-C□	108	79.4	14.2	15.7	-	80	Approx. 60	Approx. 70	Approx. 250	15	Approx. 1.7kg
PH8HF-S3-A15-T-□□-C□	108	79.2	14.2	15.7	2	70	Approx. 60	Approx. 70	Approx. 245	17	Approx. 6.1kg

F28.ai

**Flow-Through Type Holder (Explosionproof), Screw Connection, With Type Ultrasonic Cleaner**

PH8HFF-□□-□PT-T-□□-JS

UNIT : mm

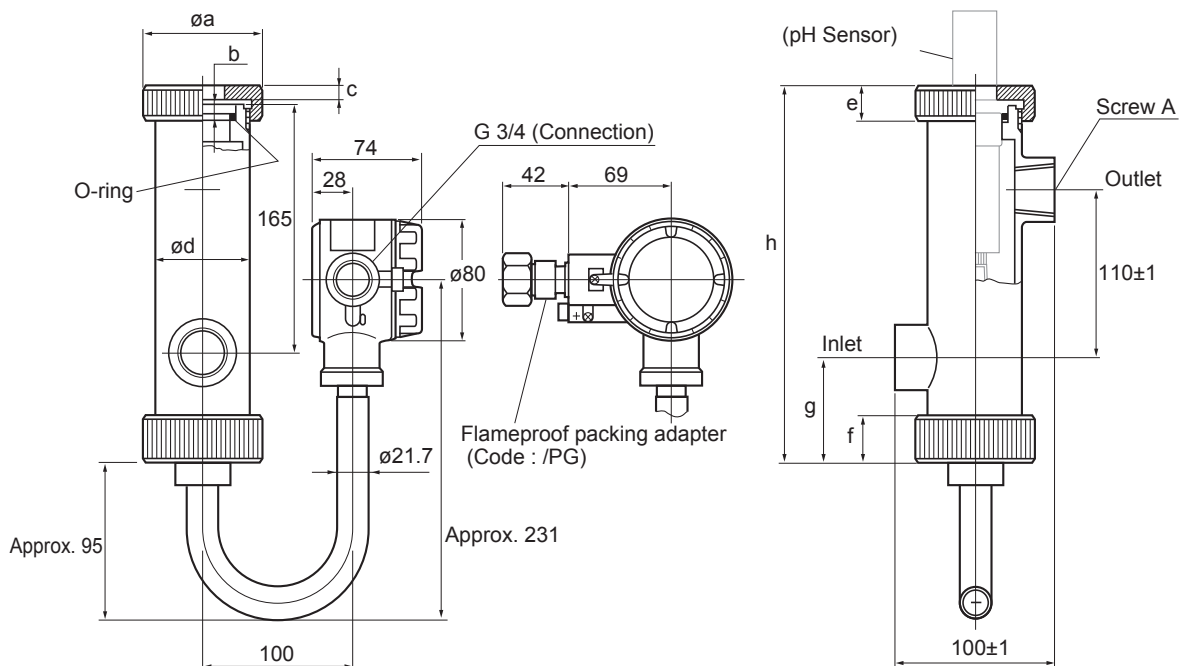

Model and Code	Screw A	a	b	c	d	e	f	g	h (Approx.)	Weight (Approx.)
PH8HFF-PP-JPT-T-□□-JS	Rc1	80	9	11	60	25	30	70	250	3kg
PH8HFF-S3-JPT-T-□□-JS	Rc1	70	10	6	60.5	26	26	69	245	5.6kg
PH8HFF-PP-NPT-T-□□-JS	1NPT	80	9	11	60	25	30	70	250	3kg
PH8HFF-S3-NPT-T-□□-JS	1NPT	70	10	6	60.5	26	26	69	245	5.6kg

F29.ai

**Flow-Through Type Holder (Explosionproof Type), Flange Connection, With Ultrasonic Cleaner**

PH8HFF-□□-□1□-T-□□-JS

UNIT : mm

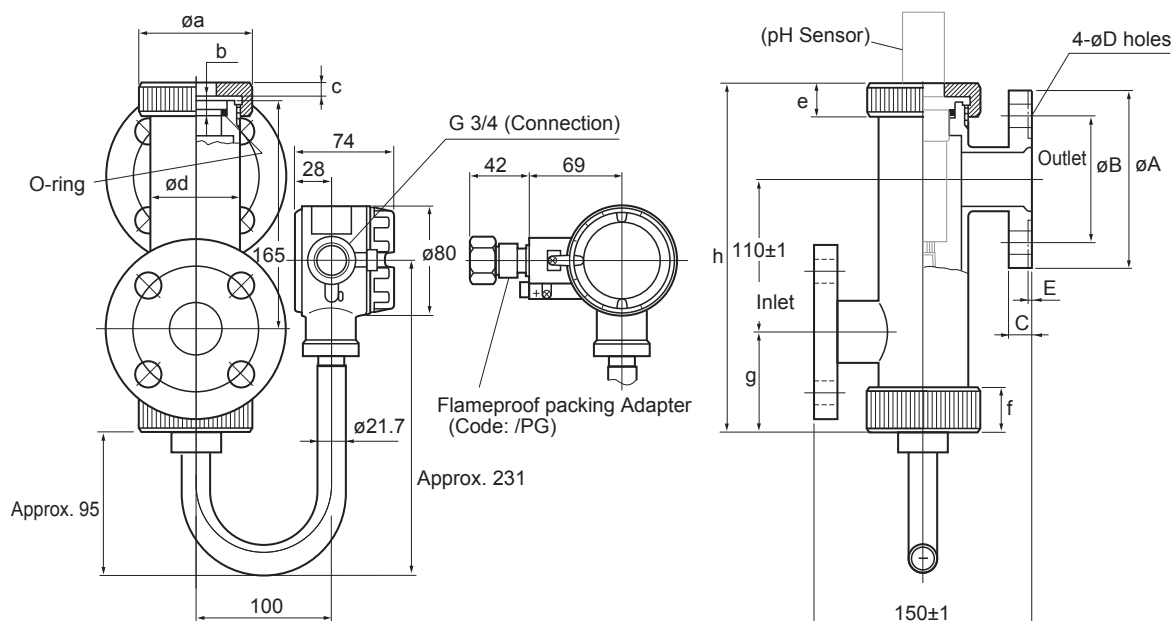

Model and Code	A	B	C	D	E	a	b	c	d	e	f	g	h (Approx.)	Weight (Approx.)
PH8HFF-PP-J10-T-□□-JS	125	90	14	19	-	80	9	11	60	25	30	70	250	3.2kg
PH8HFF-S3-J10-T-□□-JS	125	90	14	19	-	70	10	6	60.5	26	26	69	245	7.6kg
PH8HFF-PP-A15-T-□□-JS	108	79.4	14.2	15.7	-	80	9	11	60	25	30	70	250	3.2kg
PH8HFF-S3-A15-T-□□-JS	108	79.2	14.2	15.7	2	70	10	6	60.5	26	26	69	245	7.6kg

F30.ai

**Flow-Through Type Holder (For MLSS Meter), Screw Connection, Without Cleaning,**  
**(See separate drawing for mounting bracket)**

FH350G

UNIT : mm

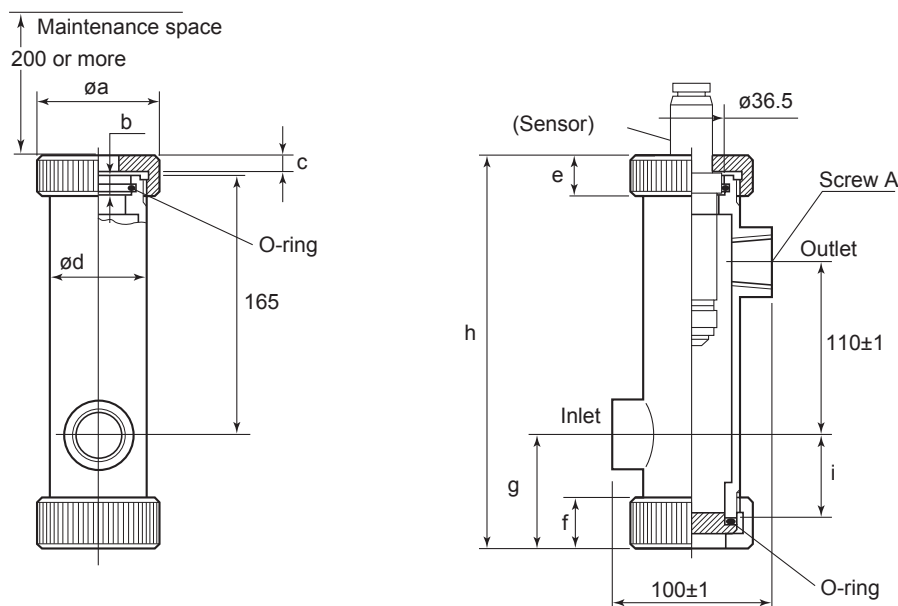

Model and Code	Screw A	a	b	c	d	e	f	g	h (Approx.)	i	Weight (Approx.)
FH350G-PP-JPT1-NN-NN	Rc1	80	8.9	12	60	25	30	70	250	54	0.4kg
FH350G-PP-NPT1-NN-NN	1NPT	80	8.9	12	60	25	30	70	250	54	0.4kg
FH350G-S3-JPT1-NN-NN	Rc1	70	8.7	6	60.5	26	26	69	245	55	3kg
FH350G-S3-JPT1-NN-NN	1NPT	70	8.7	6	60.5	26	26	69	245	55	3kg

F31.ai

**Flow-Through Type Holder (For MLSS Meter), Flange Connection, Without Cleaning**  
 (See separate drawing for mounting bracket)

FH350G

UNIT : mm

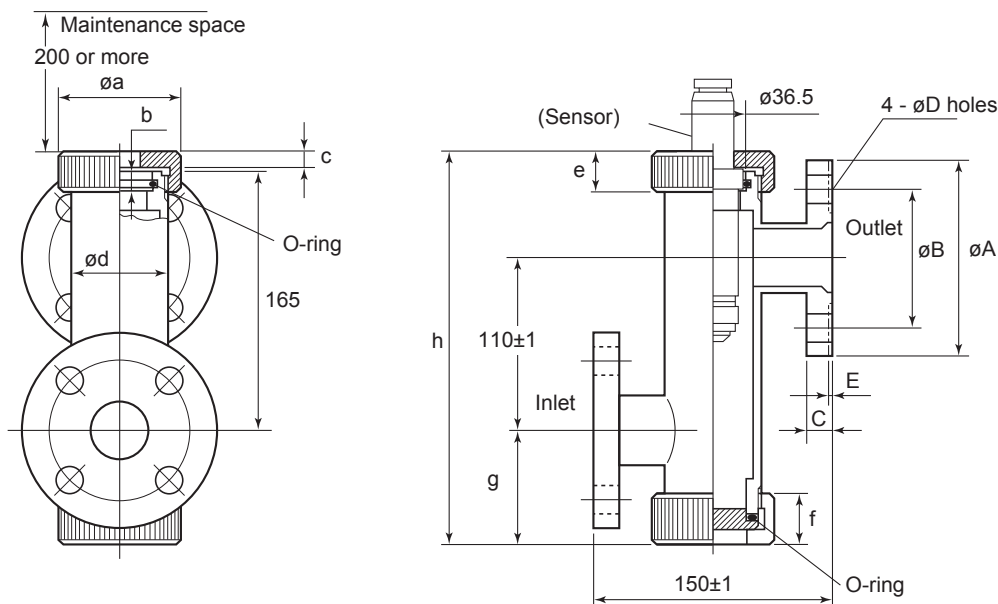

Model and Code	A	B	C	D	E	a	b	c	d	e	f	g	h (Approx.)	Weight (Approx.)
FH350G-PP-J10F-NN-NN	125	90	14	19	-	80	8.9	12	60	25	30	70	250	0.6kg
FH350G-PP-A15F-NN-NN	108	79.4	14.2	15.7	-	80	8.9	12	60	25	30	70	250	0.6kg
FH350G-S3-J10F-NN-NN	125	90	14	19	-	70	8.7	6	60.5	26	26	69	245	5kg
FH350G-S3-A15R-NN-NN	108	79.2	14.2	15.7	6	70	8.7	6	60.5	26	26	69	245	5kg

F32.ai

**Flow-Through Type Holder (For MLSS Meter), Screw Connection, With Jet Cleaner**  
 (See separate drawing for mounting bracket)

FH350G

UNIT : mm

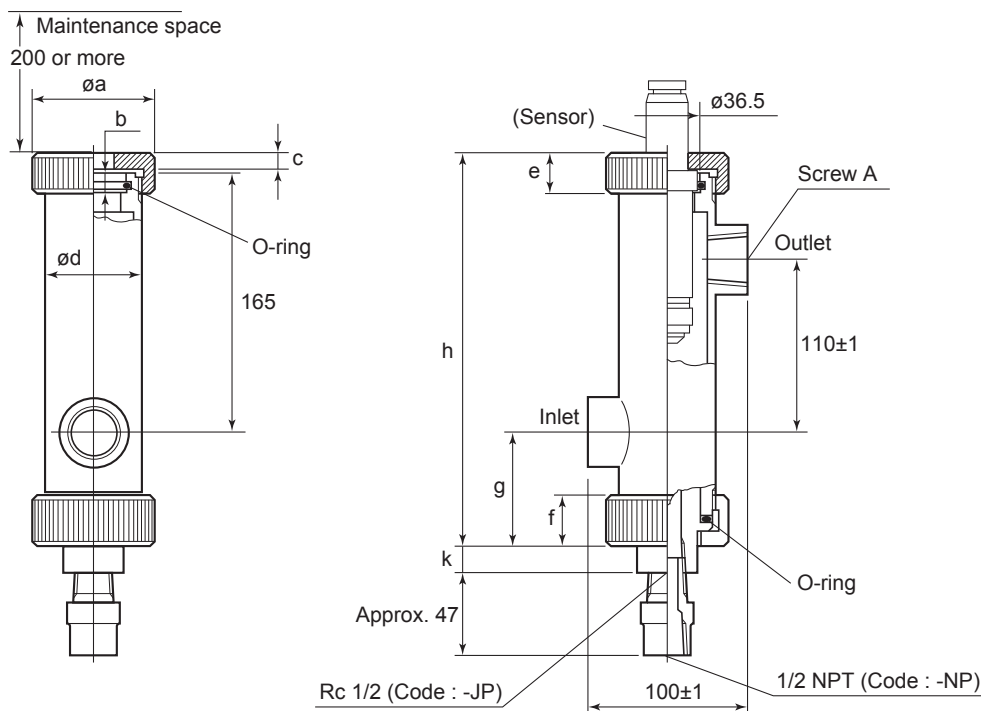

Model and Code	Screw A	A	B	C	D	E	a	b	c	d	e	f	g	h (Approx.)	k	Weight (Approx.)
FH350G-PP-JPT1-□□-□P	Rc 1	125	90	14	19	-	80	8.9	12	60	25	30	70	250	15	1.4 kg
FH350G-S3-JPT1-□□-□P	Rc 1	108	79.2	14.2	15.7	-	70	8.7	6	60.5	26	26	69	250	17	4 kg
FH350G-PP-NPT1-□□-□P	1NPT	125	90	14	19	-	80	8.9	12	60	25	30	70	250	15	1.4 kg
FH350G-S3-NPT1-□□-□P	1 NPT	108	79.2	14.2	15.7	6	70	8.7	6	60.5	26	26	69	250	17	4 kg

F33-2.ai

**Flow-Through Type Holder (For MLSS Meter), With Jet Cleaner (See separate drawing for mounting bracket)**  
 FH350G UNIT : mm

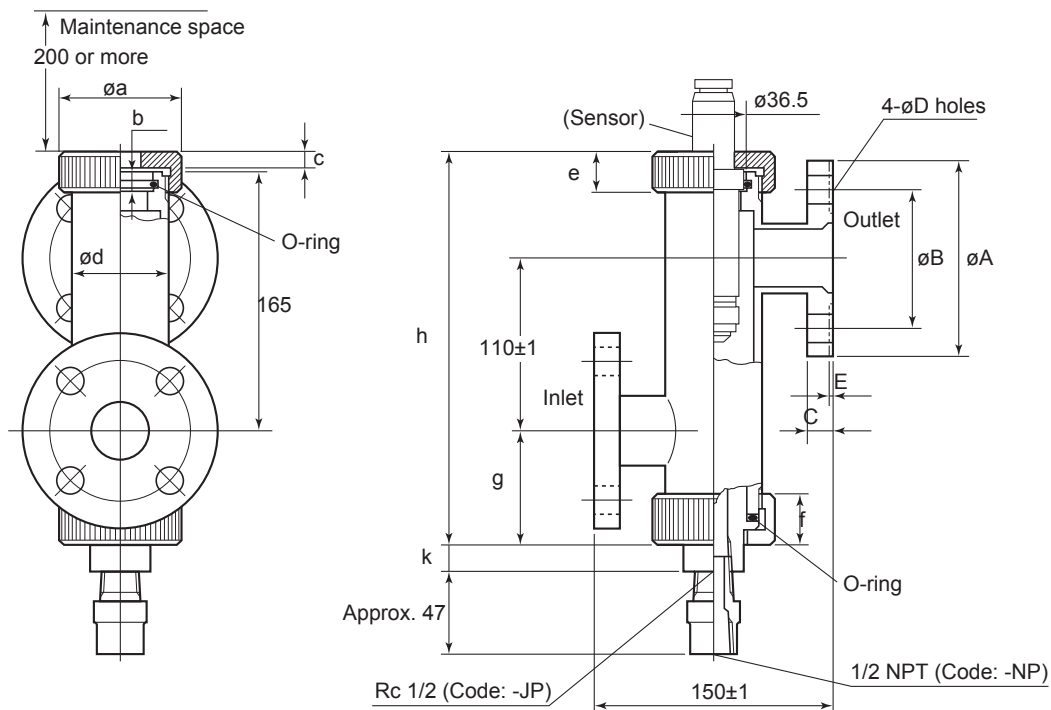

Model and Code	A	B	C	D	E	a	b	c	d	e	f	g	h (Approx.)	k	Weight (Approx.)
FH350G-PP-J10F-JT-□P	125	90	14	19	2	80	9	11	60	25	30	70	250	15	1.6 kg
FH350G-PP-A15F-JT-□P	108	79.4	14.2	15.7	2	80	9	11	60	25	30	70	250	15	1.6 kg
FH350G-S3-J10F-JT-□P	125	90	14	19	2	70	8	6	60.5	26	26	69	245	17	6 kg
FH350G-S3-A15R-JT-□P	108	79.4	14.2	15.7	2	70	8	6	60.5	26	26	69	245	17	6 kg

F33.2a.ai

**Mounting Bracket for Flow-Through Type Holder**  
 (PH8HF--)/MF1, (PH8HF--)/MF1, (FH350G--)/MF5

UNIT : mm

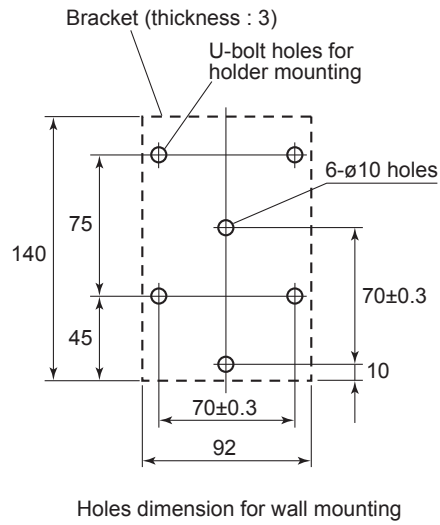
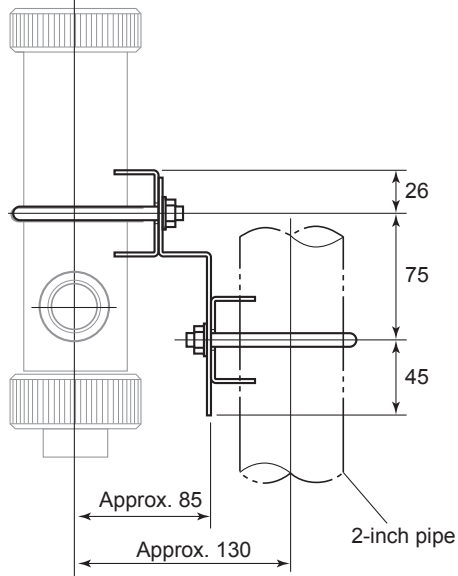

F35.ai

(PH8HF-PV- -)/MF1

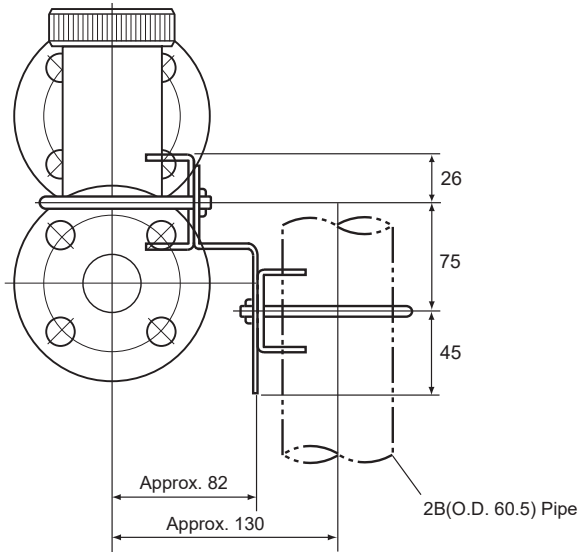

(PH8HF-PV- -)/MF1

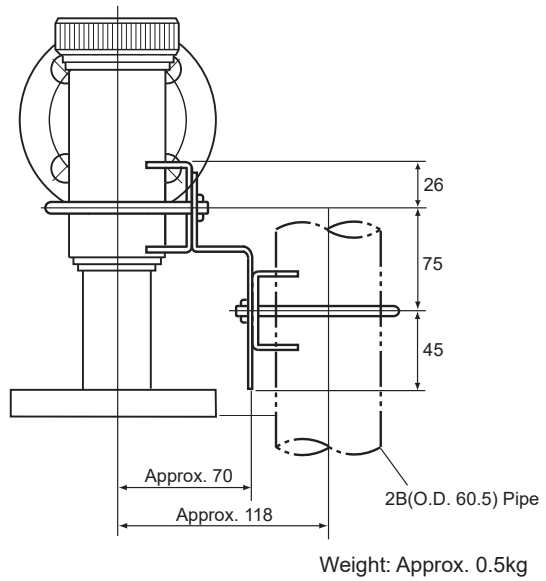

**Suspension Type Holder**

HH350G

UNIT : mm

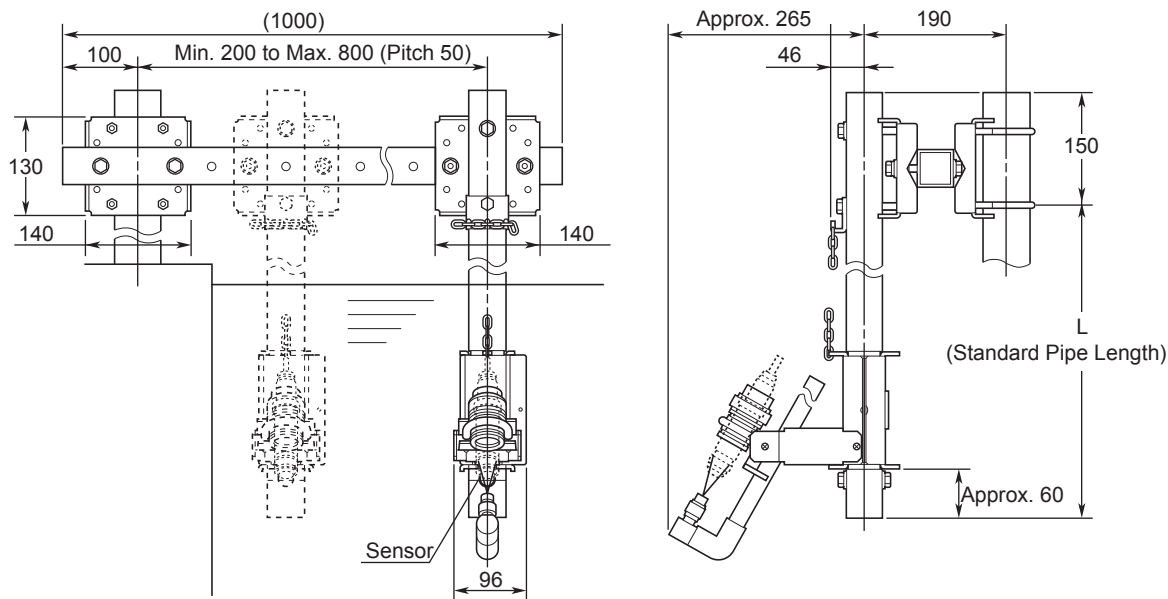

Specification of Holder (Model and Code)	Weight			
	Nominal Holder Length (L)			
	1000mm [Code : -10]	2000mm [Code : -20]	3000mm [Code : -30]	4000mm [Code : -40]
Without Cleaner HH350G-NN-□□-NN-NN	6.4 kg	8.7 kg	11 kg	13.3 kg
With Jet Cleaner HH350G-NN-□□-JT-□P	6.9 kg	9.2 kg	11.5 kg	13.8 kg

F36.ai

**Angled Floating Ball Holder**

PB350G-PV, Arm Material: PVC

UNIT : mm

• Holder

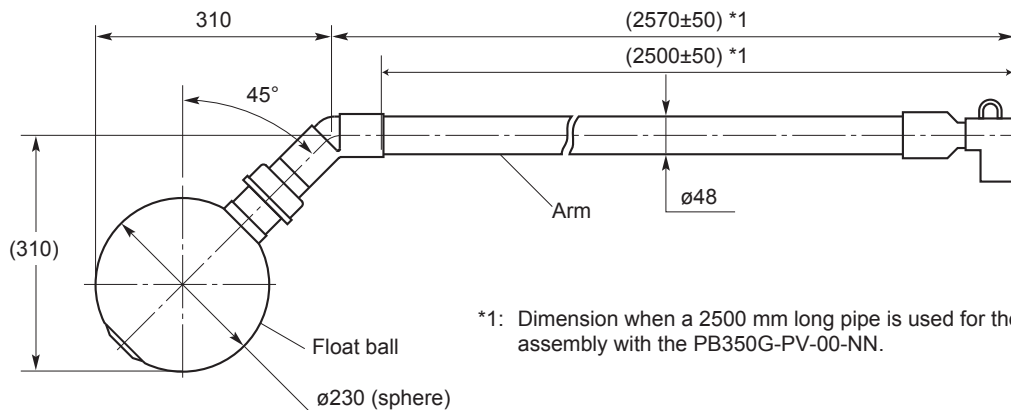

\*1: Dimension when a 2500 mm long pipe is used for the arm assembly with the PB350G-PV-00-NN.

F37.ai

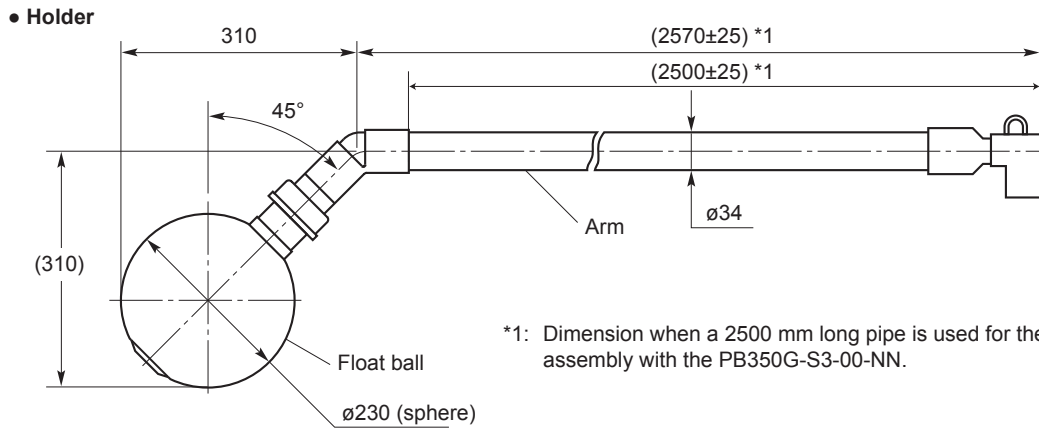

● **Mounting Bracket**

Pipe Mounting with U-bolts

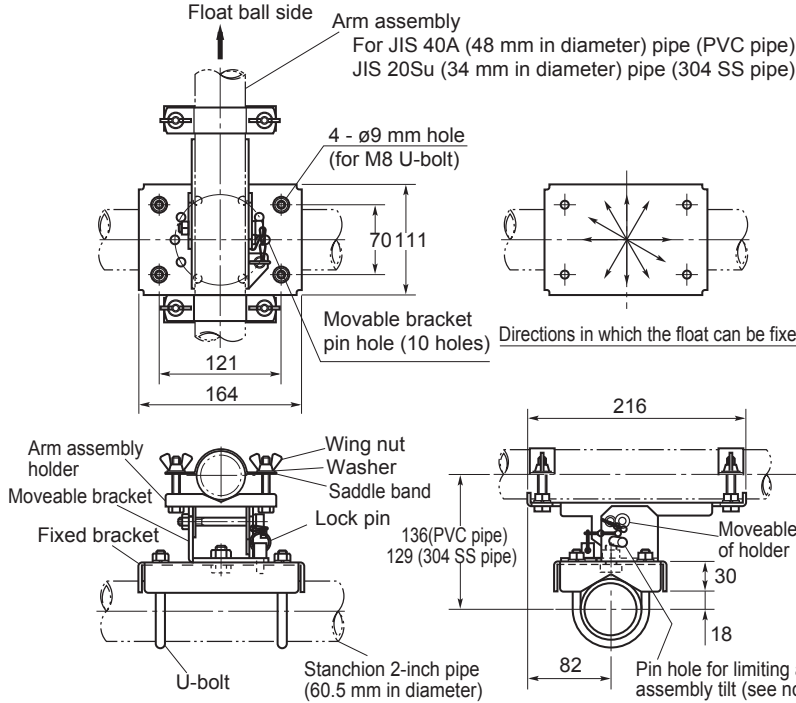

Note: When the lock pin is inserted in the pin hole for limiting arm assembly tilt, the arm assembly holder is tilted at about 30° (in float rising direction).

F39.ai

**Vertical Floating Ball Holder**  
PB360G-PV, Arm Material: PVC

UNIT : mm

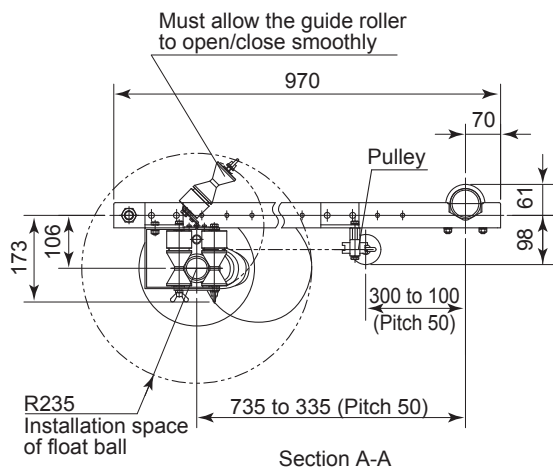
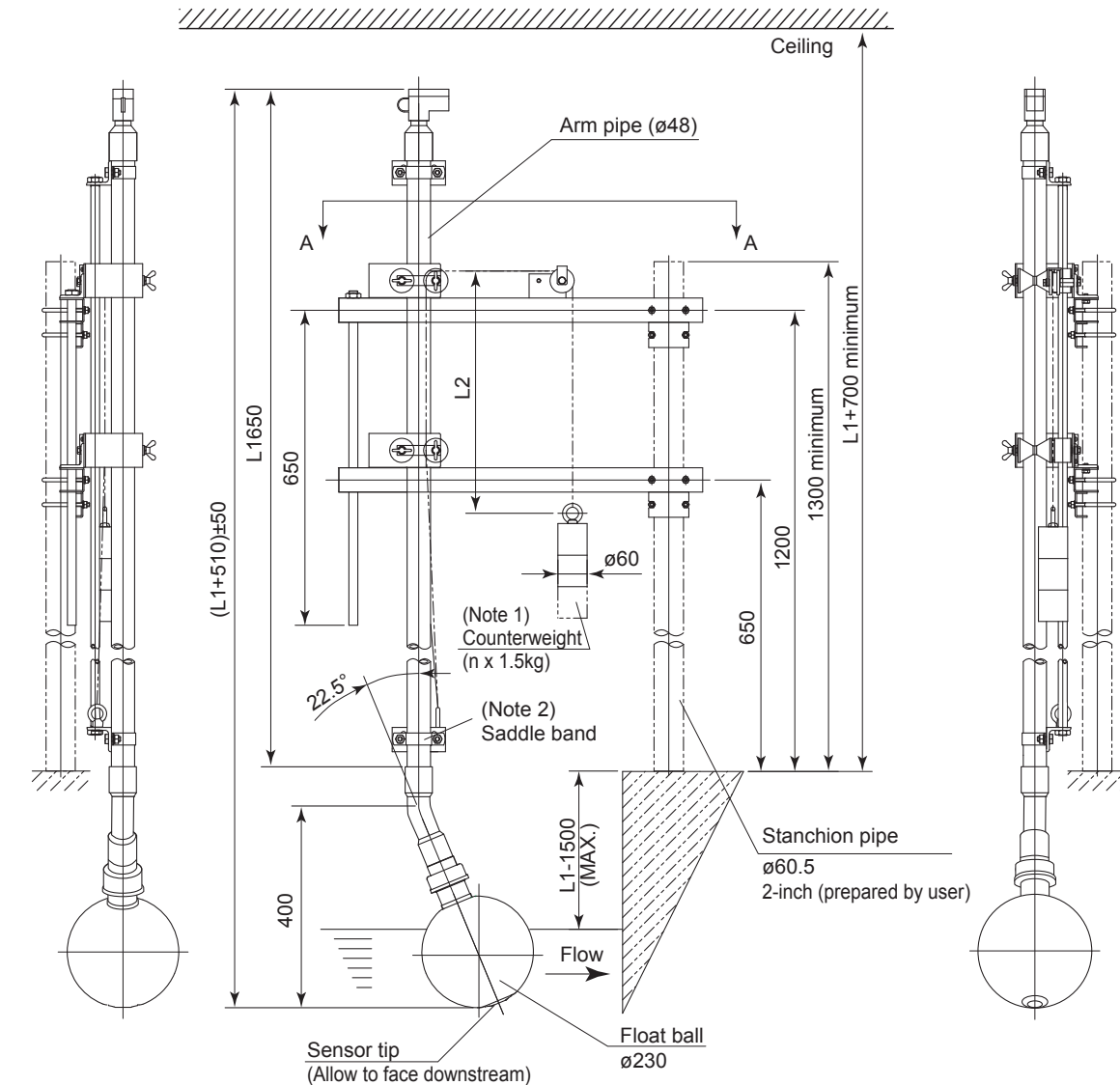

- Note 1: Adjust the weight so that the fluid surface level is equal to or above the center of the float ball.  
(Two weights when L1=2.5 m; three weights when L1=3.5 m)
- Note 2: Before fixing the saddle band, adjust the orientation of the holder so that the sensor tip faces downstream.

L1= Holder length specified  
L2= Half the maximum span +150 mm. However, if the counterweight touches the stanchion pipe installed, adjust the position of the pulley so that the counterweight can freely move up and down inside the tank.

F40.ai



Solenoid valve

UNIT : mm

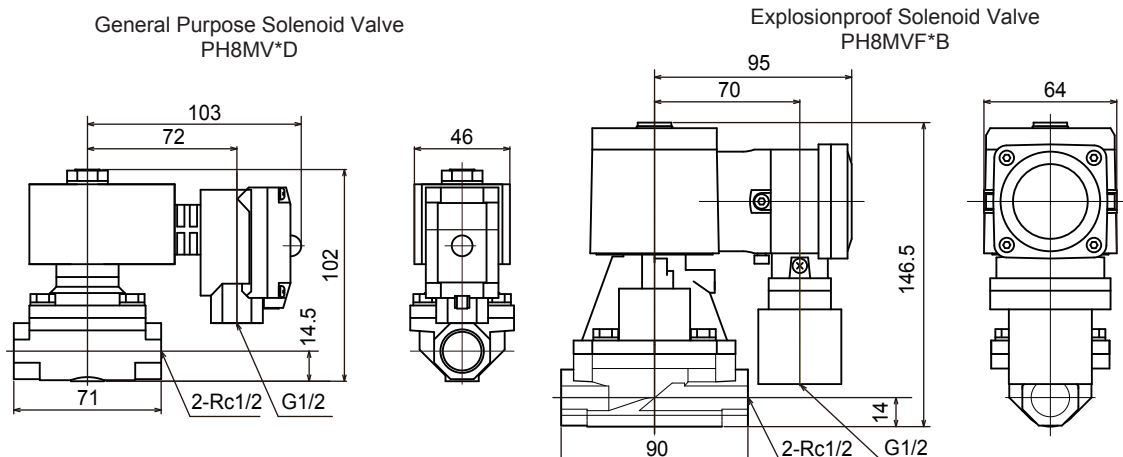

Cautions on Installation of Solenoid Valve for Jet / Brush Cleaning

1. Do not allow a sample solution to flow backward into the solenoid valve or to be replaced with the driving fluid. For this take relevant measures; e.g. install a check valve to prevent inverse pressure between the inlet and outlet of the solenoid valve, or install the solenoid valve higher than the holder, especially when using the air jet/brush cleaning system.
2. Make sure to avoid the risk of corrosion of the solenoid body (bronze) and seal (nitrile rubber) by vapor or gaseous components generated from a sample solution, especially when using the air jet/brush cleaning system.

F43.ai

Ultrasonic Oscillator (Non-Explosionproof Type)  
PUS400G

UNIT : mm

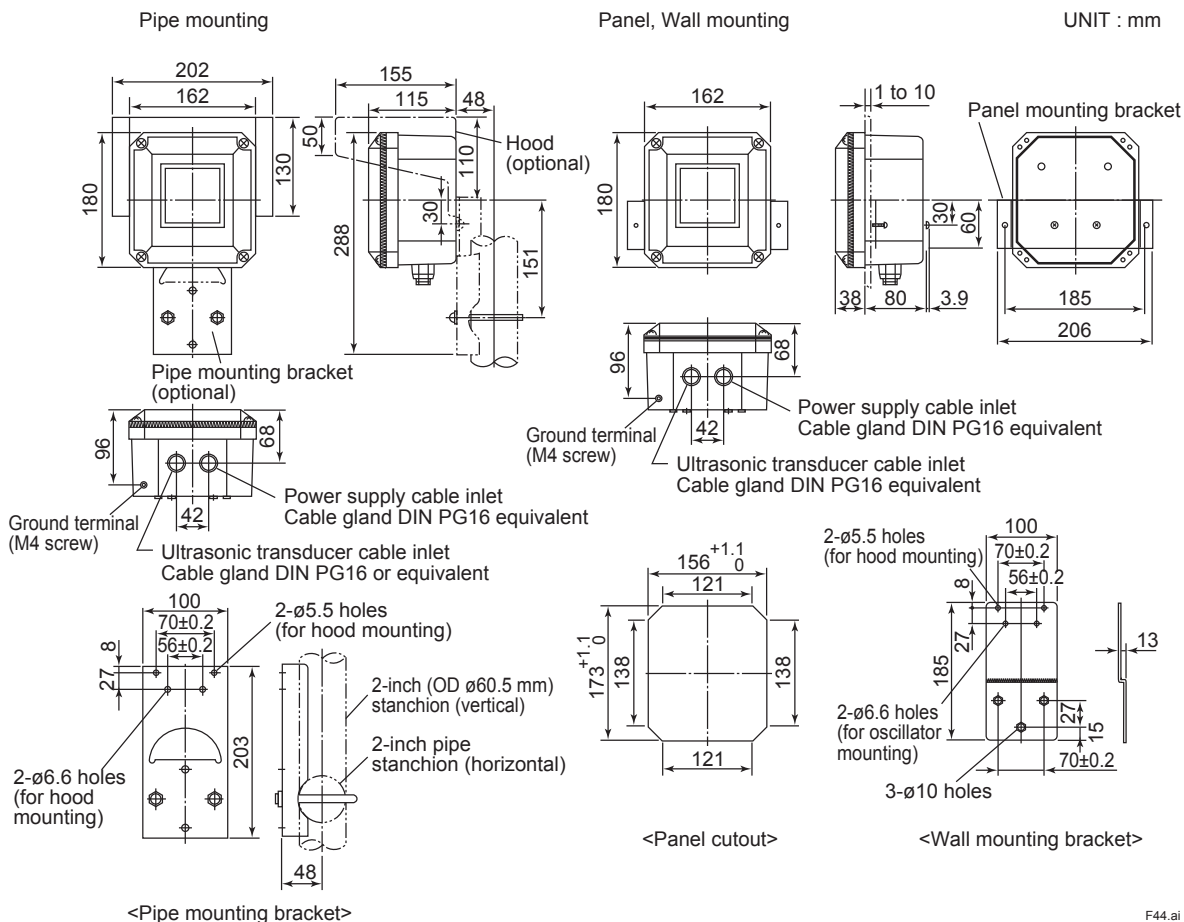

F44.ai

• External dimensions of additional noise filter assembly when PUS400G-NN-KC

UNIT : mm

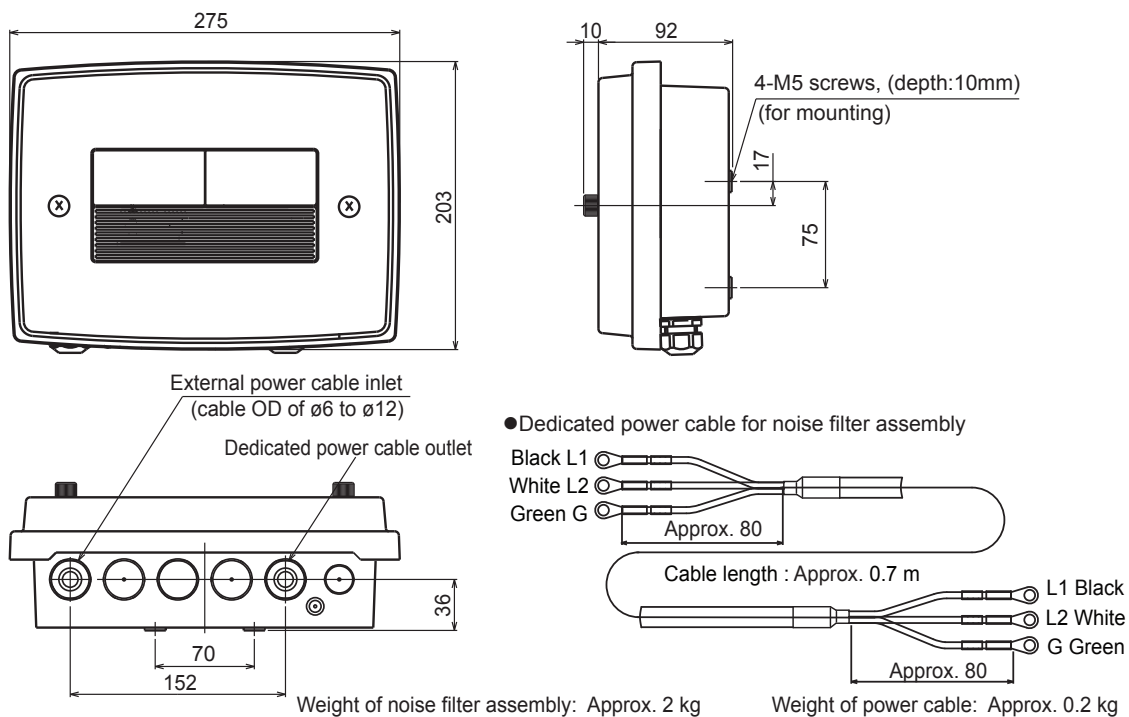

• Pipe mounting bracket for additional noise filter assembly (option code: /PS)

UNIT : mm

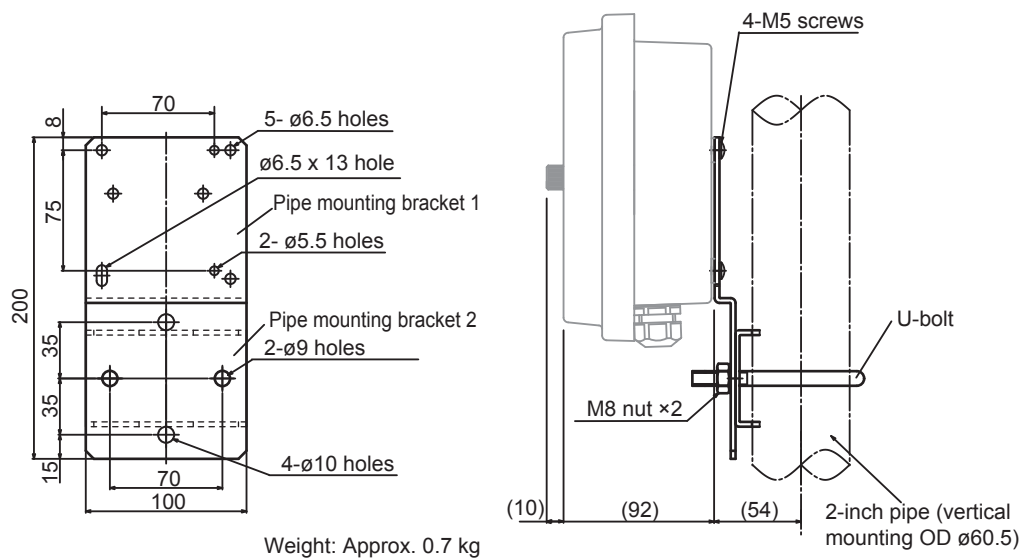

- Wall or Panel mounting bracket for additional noise filter assembly (option code: /W, /PA) UNIT : mm

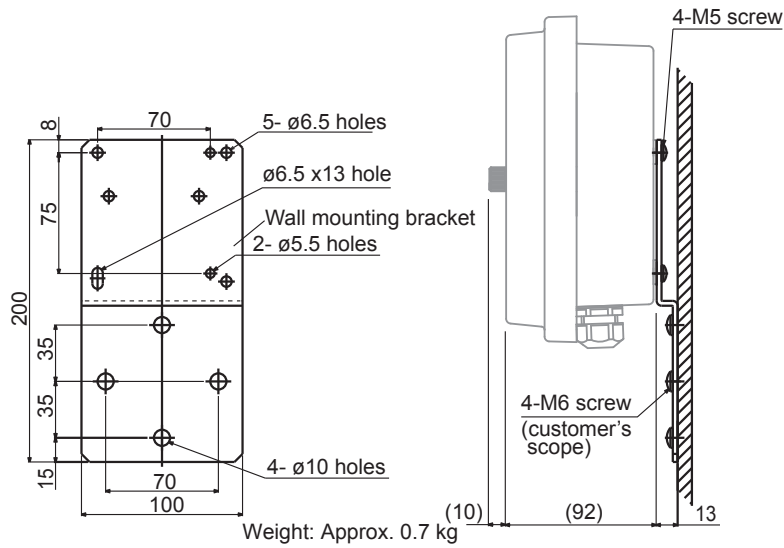

**Ultrasonic Oscillator (Explosionproof Type)**  
PH8USF UNIT : mm

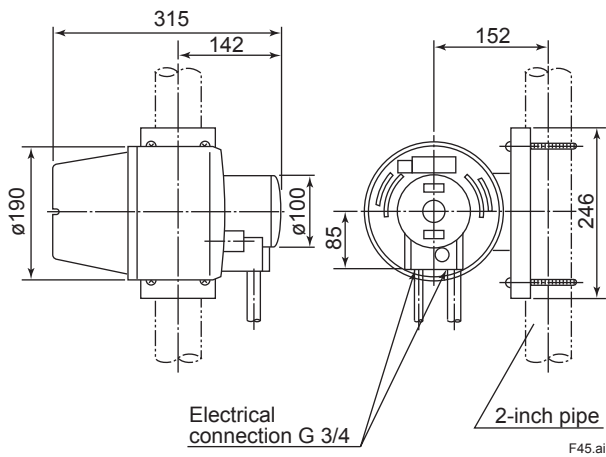

**Alarm Box**  
PH8AL UNIT : mm

