



# Temperature Converter HiC2081

- 1-channel isolated barrier
- 24 V DC supply (bus powered)
- Thermocouple, RTD, potentiometer or voltage input
- Linearized output 4 mA ... 20 mA, sink/source
- Sensor breakage detection
- Configurable by PACTware
- Line fault detection (LFD)
- Up to SIL 2 acc. to IEC/EN 61508



## Function

This isolated barrier is used for intrinsic safety applications. This device accepts thermocouples (TC), millivolts, potentiometers, or resistance temperature detectors (RTD) from a hazardous area and converts them to an isolated, linearized analog output in the safe area. The output can be selected as a current source or current sink with a switch. Line fault detection of the field circuit is indicated by a red LED and an output on the fault bus. The fault conditions are monitored via a Fault Indication Board. The device is easily configured by the use of the PACTware configuration software. This device mounts on a HiC Termination Board.

## Connection

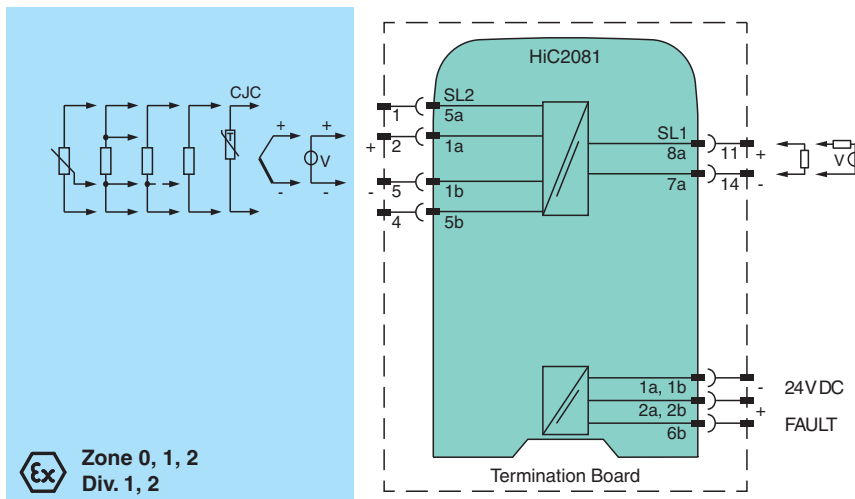

## Technical Data

### General specifications

Signal type Analog input

### Functional safety related parameters

Safety Integrity Level (SIL) SIL 2

### Supply

Connection SL1: 1a, 1b(-); 2a, 2b(+)

Rated voltage  $U_r$  20 ... 30 V DC bus powered via Termination Board

Ripple within the supply tolerance

Power dissipation  $\leq 0.98$  W

Release date: 2022-03-17 Date of issue: 2022-03-17 Filename: 275178\_eng.pdf

Refer to "General Notes Relating to Pepperl+Fuchs Product Information".

Pepperl+Fuchs Group  
www.pepperl-fuchs.com

USA: +1 330 486 0002  
pa-info@us.pepperl-fuchs.com

Germany: +49 621 776 2222  
pa-info@de.pepperl-fuchs.com

Singapore: +65 6779 9091  
pa-info@sg.pepperl-fuchs.com

**PEPPERL+FUCHS**

## Technical Data

Power consumption	max. 0.98 W
<b>Interface</b>	
Programming interface	programming socket
<b>Input</b>	
Connection side	field side
Connection	SL2: 5a(+), 1a(+), 1b(-), 5b(-)
RTD	type Pt10, Pt50, Pt100, Pt500, Pt1000 (EN 60751: 1995) type Pt10GOST, Pt50GOST, Pt100GOST, Pt500GOST, Pt1000GOST (6651-94) type Cu10, Cu50, Cu100 (P50353-92) type Ni100 (DIN 43760)
Measuring current	approx. 200 $\mu$ A with RTD
Types of measuring	2-, 3-, 4-wire connection
Lead resistance	max. 50 $\Omega$ per line
Measurement loop monitoring	sensor breakage, sensor short-circuit
Thermocouples	type B, E, J, K, N, R, S, T (IEC 584-1: 1995) type L (DIN 43710: 1985) type TXK, TXKH, TXA (P8.585-2001)
Cold junction compensation	external and internal
Measurement loop monitoring	sensor breakage
Potentiometer	0 ... 20 k $\Omega$ (2-wire connection), 0.8 ... 20 k $\Omega$ (3-wire connection)
Types of measuring	3-wire connection
Voltage	selectable within the range -100 ... 100 mV
Input resistance	$\geq$ 1 M $\Omega$ (-100 ... 100 mV)
<b>Output</b>	
Connection side	control side
Connection	SL1: 8a(+), 7a(-)
Output	Analog current output
Current range	0 ... 20 mA or 4 ... 20 mA
Fault signal	downscale 0 or 2 mA, upscale 21.5 mA (acc. NAMUR NE43)
Source	load 0 ... 550 $\Omega$ open-circuit voltage $\leq$ 18 V
Sink	Voltage across terminals 5 ... 30 V. If the current is supplied from a source $>$ 25 V, series resistance of $\geq$ (V - 25)/0.0215 $\Omega$ is needed, where V is the source voltage. The maximum value of the resistance is (V - 5)/0.0215 $\Omega$ .
<b>Fault indication output</b>	
Connection	SL1: 6b
Output type	open collector transistor (internal fault bus)
<b>Transfer characteristics</b>	
Deviation	
After calibration	Pt100: $\pm$ (0.06 % of measurement value in K + 0.1 % of span + 0.1 K (4-wire connection)) thermocouple: $\pm$ (0.05 % of measurement value in $^{\circ}$ C + 0.1 % of span + 1 K (1.2 K for types R and S)), includes $\pm$ 0.8 K fault of the cold junction compensation (CJC) mV: $\pm$ (50 $\mu$ V + 0.1 % of span) potentiometer: $\pm$ (0.05 % of full scale + 0.1 % of span, (excludes faults due to lead resistance))
Influence of ambient temperature	Pt100: $\pm$ (0.0015 % of measurement value in K + 0.006 % of span)/K $\Delta T_{amb}^{1)}$ thermocouple: $\pm$ (0.02 K + 0.005 % of measurement value in $^{\circ}$ C + 0.006 % of span)/K $\Delta T_{amb}^{1)}$ , influence of cold junction compensation (CJC) included mV: $\pm$ (0.01 % of measurement value + 0.006 % of span)/K $\Delta T_{amb}^{1)}$ potentiometer: $\pm$ 0.006 % of span/K $\Delta T_{amb}^{1)}$ <sup>1)</sup> $\Delta T_{amb}$ = ambient temperature change referenced to 23 $^{\circ}$ C (296 K)
Influence of supply voltage	$<$ 0.01 % of span
Influence of load	$\leq$ 0.001 % of output value per 100 $\Omega$
Reaction time	worst case value (sensor breakage and/or sensor short circuit detection enabled) mV: 1 s, thermocouples with CJC: 1.1 s, thermocouples with fixed reference temperature: 1.1 s, 3- or 4-wire RTD: 920 ms, 2-wire RTD: 800 ms, Potentiometer: 2.05 s
<b>Galvanic isolation</b>	
Output/supply, programming input	functional insulation, rated insulation voltage 50 V AC There is no electrical isolation between the programming input and the supply. The programming cable provides galvanic isolation so that ground loops are avoided.

Release date: 2022-03-17 Date of issue: 2022-03-17 Filename: 275178\_eng.pdf

## Technical Data

<b>Indicators/settings</b>			
Display elements		LEDs	
Control elements		DIP switch	
Configuration		via DIP switches via PACTware	
Labeling		space for labeling at the front	
<b>Directive conformity</b>			
Electromagnetic compatibility			
Directive 2014/30/EU		EN 61326-1:2013 (industrial locations)	
<b>Conformity</b>			
Electromagnetic compatibility		NE 21:2012 EN 61326-3-2:2008	
Degree of protection		IEC 60529:2001	
Protection against electrical shock		UL 61010-1:2012	
<b>Ambient conditions</b>			
Ambient temperature		-20 ... 70 °C (-4 ... 158 °F)	
Relative humidity		5 ... 90 %, non-condensing up to 35 °C (95 °F)	
<b>Mechanical specifications</b>			
Degree of protection		IP20	
Mass		approx. 100 g	
Dimensions		12.5 x 106 x 128 mm (0.5 x 4.2 x 5.1 inch) (W x H x D)	
Mounting		on Termination Board	
Coding		pin 1, 2 and 4 trimmed For further information see system description.	
<b>Data for application in connection with hazardous areas</b>			
EU-type examination certificate		BASEEFA 14 ATEX 0129 X	
Marking		Ⓜ II (1)G [Ex ia Ga] IIC Ⓜ II (1)D [Ex ia Da] IIIC Ⓜ I (M1) [Ex ia Ma] I	
Input		[Ex ia Ga] IIC, [Ex ia Da] IIIC, [Ex ia Ma] I	
Voltage	U <sub>o</sub>	9 V	
Current	I <sub>o</sub>	13.1 mA	
Power	P <sub>o</sub>	30 mW	
Analog outputs, power supply, collective error			
Maximum safe voltage	U <sub>m</sub>	250 V (Attention! This is not the rated voltage.)	
Interface			
Maximum safe voltage	U <sub>m</sub>	250 V (Attention! The rated voltage is lower.), RS 232	
Certificate			
Marking		Ⓜ II 3G Ex nA II T4 Gc [device in zone 2]	
Galvanic isolation			
Input/Other circuits		safe electrical isolation acc. to IEC/EN 60079-11, voltage peak value 375 V	
Directive conformity			
Directive 2014/34/EU		EN 60079-0:2012+A11:2013 , EN 60079-11:2012 , EN 60079-15:2010	
<b>International approvals</b>			
FM approval			
Control drawing		116-0429 (cFMus)	
UL approval			
Control drawing		116-0391 (cULus)	
IECEx approval			
IECEx certificate		IECEx BAS 14.0071X IECEx BAS 16.0003X	
IECEx marking		[Ex ia Ga] IIC , [Ex ia Da] IIIC , [Ex ia Ma] I Ex nA IIC T4 Gc	
<b>General information</b>			
Supplementary information		Observe the certificates, declarations of conformity, instruction manuals, and manuals where applicable. For information see <a href="http://www.pepperl-fuchs.com">www.pepperl-fuchs.com</a> .	

Release date: 2022-03-17 Date of issue: 2022-03-17 Filename: 275178\_eng.pdf

Refer to "General Notes Relating to Pepperl+Fuchs Product Information".

Pepperl+Fuchs Group  
[www.pepperl-fuchs.com](http://www.pepperl-fuchs.com)USA: +1 330 486 0002  
pa-info@us.pepperl-fuchs.comGermany: +49 621 776 2222  
pa-info@de.pepperl-fuchs.comSingapore: +65 6779 9091  
pa-info@sg.pepperl-fuchs.com



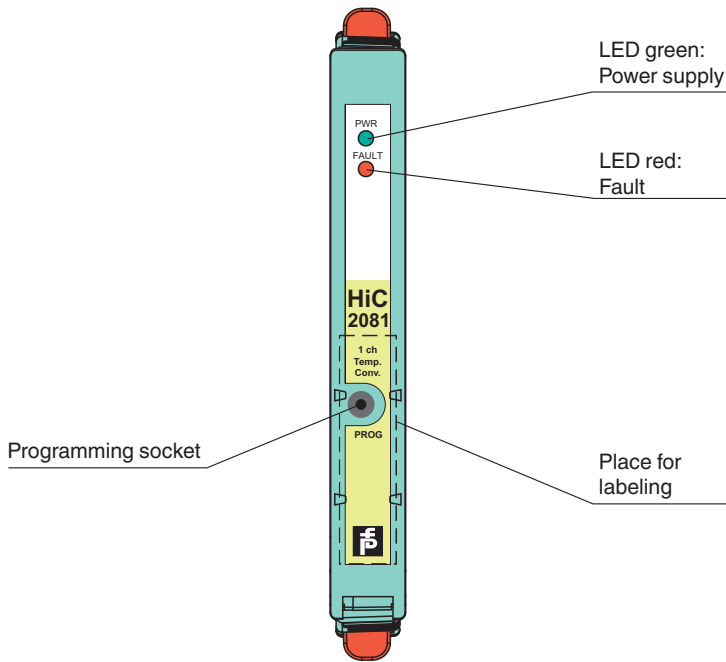

**PEPPERL+FUCHS**

**Assembly**

Front view



**Accessories**

	<b>H-CJC-Pt100</b>	Resistance thermometer for cold junction compensation for H-System termination boards
	<b>K-ADP-USB</b>	Programming adapter with USB interface
	<b>DTM Interface Technology</b>	Device type manager (DTM) for interface technology
	<b>PACTware 5.X</b>	FDT Framework

Release date: 2022-03-17 Date of issue: 2022-03-17 Filename: 275178\_eng.pdf

Refer to "General Notes Relating to Pepperl+Fuchs Product Information".

Pepperl+Fuchs Group  
www.pepperl-fuchs.com

USA: +1 330 486 0002  
pa-info@us.pepperl-fuchs.com

Germany: +49 621 776 2222  
pa-info@de.pepperl-fuchs.com

Singapore: +65 6779 9091  
pa-info@sg.pepperl-fuchs.com

## Application

The resistance thermometer for cold junction compensation H-CJC-\*\*-8 is available as an accessory for temperature measurements with thermocouples.

## Configuration

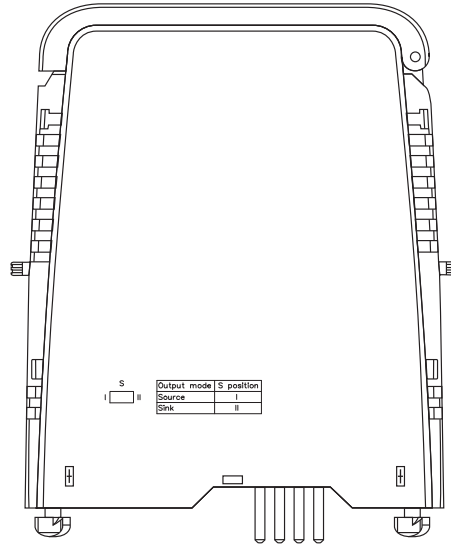

### Switch position

Output mode	Switch position
Source	I
Sink	II

Configure the device in the following way:

- Push the red Quick Lok Bars on each side of the device in the upper position.
- Remove the device from Termination Board.
- Set the switches according to the figure.



*The pins for this device are trimmed to polarize it according to its safety parameters. Do not change! For further information see system description.*