



# SMART Current Driver HiD2038

- 2-channel isolated barrier
- 24 V DC supply (bus powered)
- Current output up to 650 Ω load
- SMART I/P and valve positioners
- Line fault detection (LFD)
- Accuracy 0.1%
- Up to SIL 2 acc. to IEC 61508



SIL 2



## Function

This isolated barrier is used for intrinsic safety applications.

The device repeats the input signal from a control system to drive HART I/P converters, electrical valves, and positioners located in a hazardous area.

Digital signals are superimposed on the analog values at the field side or control side and are transferred bi-directionally.

Current transferred across the DC/DC converter is repeated at the terminals 5a, 5b (1a, 1b). The terminals 5b, 7a (1b, 3b) are used when no short-circuit detection is required.

An open or short field circuit presents a high impedance to the control side to allow alarm conditions to be monitored by the control system. Line fault detection of the field circuit is indicated by a red LED and an output on the fault bus. The fault conditions are monitored via a Fault Indication Board.

This device mounts on a HiD Termination Board.

## Connection

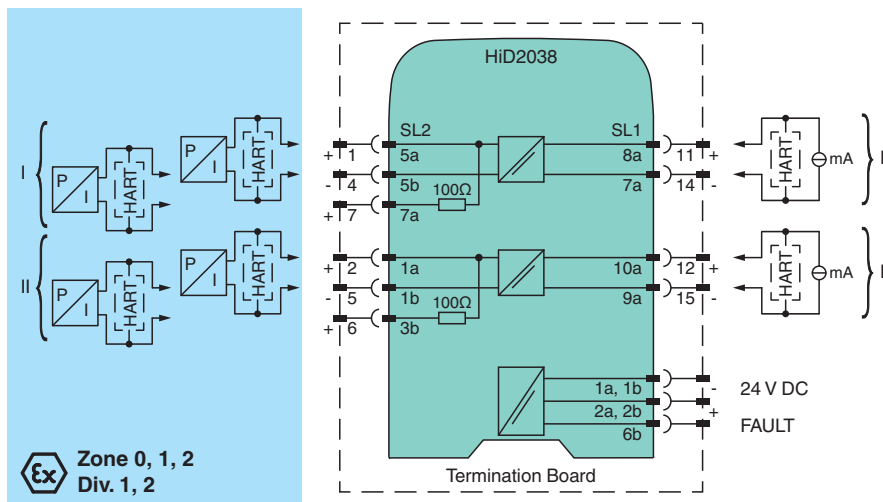

## Technical Data

General specifications	
Signal type	Analog output
Functional safety related parameters	
Safety Integrity Level (SIL)	SIL 2
Supply	
Connection	SL1: 1a(-), 1b(-); 2a(+), 2b(+)
Rated voltage	$U_r$ 19 ... 30 V DC bus powered via Termination Board
Ripple	≤ 10 %

Release date: 2021-02-09 Date of issue: 2021-02-09 Filename: 322869\_eng.pdf

Refer to "General Notes Relating to Pepperl+Fuchs Product Information".

Pepperl+Fuchs Group  
www.pepperl-fuchs.com

USA: +1 330 486 0002  
pa-info@us.pepperl-fuchs.com

Germany: +49 621 776 2222  
pa-info@de.pepperl-fuchs.com

Singapore: +65 6779 9091  
pa-info@sg.pepperl-fuchs.com



## Technical Data

Rated current	$I_r$	$\leq 40$ mA at 24 V
Power dissipation		$\leq 1$ W at 20 mA and 500 $\Omega$ load
Power consumption		$\leq 1$ W
<b>Input</b>		
Connection side		control side
Connection		SL1: 8a(+), 7a(-); 10a(+), 9a(-)
Input signal		4 ... 20 mA, limited to approx. 30 mA
Input voltage		open loop voltage of the control system $\leq 30$ V
Voltage drop		approx. 6 V at 20 mA
Input resistance		field wiring open circuit : $> 100$ k $\Omega$ field wiring $< 50$ $\Omega$ : $> 100$ k $\Omega$ when using terminals 5a, 5b; 1a, 1b
<b>Output</b>		
Connection side		field side
Connection		SL2: 5a(+), 5b(-); 1a(+), 1b(-) SL2: 5b(-), 7a(+); 1b(-), 3b(+) (no short circuit detection)
Voltage		$\geq 13$ V at 20 mA
Current		4 ... 20 mA
Load		100 ... 650 $\Omega$ , for terminals 1a, 1b; 5a, 5b 0 ... 550 $\Omega$ , for terminals 1b, 3b; 5b, 7a
Ripple		20 mV rms
Line fault detection		breakage, load $> 100$ k $\Omega$ , short-circuit, load $< 50$ $\Omega$
<b>Fault indication output</b>		
Connection		SL1: 6b
Output type		open collector transistor (internal fault bus)
<b>Transfer characteristics</b>		
Deviation		at 20 °C (68 °F), 4 ... 20 mA $< 0.1$ % of full scale, incl. non-linearity and hysteresis
Influence of ambient temperature		$< 2$ $\mu$ A/K (-20 ... 70 °C (-4 ... 158 °F)); $< 4$ $\mu$ A/K (-40 ... -20 °C (-40 ... -4 °F))
Frequency range		field side into the control side: bandwidth with 0.5 V <sub>pp</sub> signal 0 ... 3 kHz (-3 dB) control side into the field side: bandwidth with 0.5 V <sub>pp</sub> signal 0 ... 3 kHz (-3 dB)
Rise time		10 to 90 % $\leq 10$ ms
<b>Galvanic isolation</b>		
Input/Output		basic insulation according to IEC/EN 61010-1, rated insulation voltage 300 V <sub>eff</sub>
Input/power supply		basic insulation according to IEC/EN 61010-1, rated insulation voltage 50 V <sub>eff</sub>
Output/power supply		basic insulation according to IEC/EN 61010-1, rated insulation voltage 300 V <sub>eff</sub>
Input/input		functional insulation, rated insulation voltage 50 V AC
<b>Indicators/settings</b>		
Display elements		LEDs
Labeling		space for labeling at the front
<b>Directive conformity</b>		
Electromagnetic compatibility		
Directive 2014/30/EU		EN 61326-1:2013 (industrial locations)
<b>Conformity</b>		
Electromagnetic compatibility		NE 21:2017 EN 61326-3-2:2018 For further information see system description.
Degree of protection		IEC 60529
Protection against electrical shock		UL 61010-1:2012
<b>Ambient conditions</b>		
Ambient temperature		-40 ... 70 °C (-40 ... 158 °F)
<b>Mechanical specifications</b>		
Degree of protection		IP20
Mass		approx. 140 g
Dimensions		18 x 106 x 128 mm (0.7 x 4.2 x 5 inch)
Mounting		on Termination Board

Release date: 2021-02-09 Date of issue: 2021-02-09 Filename: 322869\_eng.pdf

**Technical Data**

Coding		pin 1 and 3 trimmed For further information see system description.
<b>Data for application in connection with hazardous areas</b>		
EU-type examination certificate		DEMKO 20 ATEX 2378 X
Marking		Ⓜ II (1)G [Ex ia Ga] IIC Ⓜ II (1)D [Ex ia Da] IIIC Ⓜ I (M1) [Ex ia Ma] I
Output		Ex ia, Ex iaD
Voltage	$U_o$	25.2 V
Current	$I_o$	93 mA
Power	$P_o$	585.3 mW
Internal capacitance	$C_i$	1.05 nF
Internal inductance	$L_i$	0
<b>Supply</b>		
Maximum safe voltage	$U_m$	250 V <sub>rms</sub> (Attention! The rated voltage can be lower.)
<b>Input</b>		
Maximum safe voltage	$U_m$	250 V <sub>rms</sub> (Attention! The rated voltage can be lower.)
Certificate		DEMKO 20 ATEX 2379 X
Marking		Ⓜ II 3G Ex ec IIC T4 Gc
<b>Galvanic isolation</b>		
Input/Output		safe electrical isolation acc. to IEC/EN 60079-11, voltage peak value 375 V
Output/power supply		safe electrical isolation acc. to IEC/EN 60079-11, voltage peak value 375 V
<b>Directive conformity</b>		
Directive 2014/34/EU		EN IEC 60079-0:2018 , EN 60079-11:2012 , EN 60079-7:2015+A1:2018
<b>International approvals</b>		
UL approval		E106378
Control drawing		116-0475 (cULus)
IECEx approval		IECEx ULD 20.0012X
Approved for		[Ex ia Ga] IIC , [Ex ia Da] IIIC , [Ex ia Ma] I , Ex ec IIC T4 Gc
<b>General information</b>		
Supplementary information		Observe the certificates, declarations of conformity, instruction manuals, and manuals where applicable. For information see <a href="http://www.pepperl-fuchs.com">www.pepperl-fuchs.com</a> .

Front view

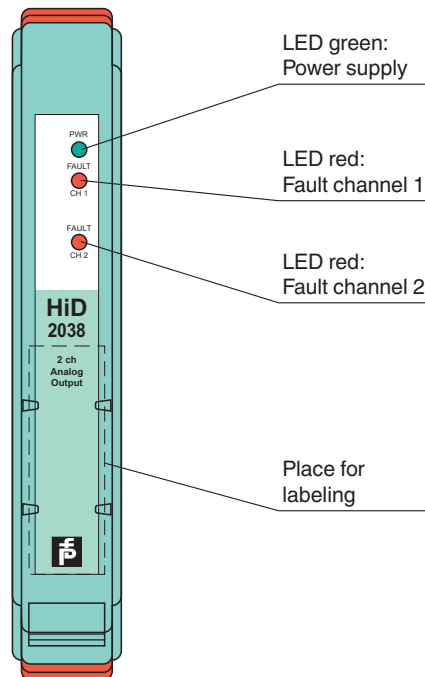

Release date: 2021-02-09 Date of issue: 2021-02-09 Filename: 322869\_eng.pdf

## Matching System Components

HiD-CI-AO1-SET
----------------

Release date: 2021-02-09 Date of issue: 2021-02-09 Filename: 322869\_eng.pdf

Refer to "General Notes Relating to Pepperl+Fuchs Product Information".

Pepperl+Fuchs Group  
www.pepperl-fuchs.com

USA: +1 330 486 0002  
pa-info@us.pepperl-fuchs.com

Germany: +49 621 776 2222  
pa-info@de.pepperl-fuchs.com

Singapore: +65 6779 9091  
pa-info@sg.pepperl-fuchs.com

## Configuration

No user configuration available for this device.



*The pins for this device are trimmed to polarize it according to its safety parameter. Do not change!  
For further information see system description.*