

SMART Current Driver

HiD2038Y

SIL 2



- 2-channel isolated barrier
- 24 V DC supply (bus powered)
- Current output up to 750 Ω load
- SMART I/P and valve positioners
- Suitable for Yokogawa PCS system
- Line fault detection (LFD)
- Up to SIL 2 acc. to IEC 61508



Function

This isolated barrier is used for intrinsic safety applications. It repeats a 4 mA ... 20 mA input signal from a control system to drive SMART I/P converters, valve actuators, and displays located in a hazardous area. Digital signals may be superimposed on the analog values in the hazardous or safe area, which are transferred bidirectionally. An open field circuit presents a high impedance to the control side to allow alarm conditions to be monitored by control systems. Line fault detection of the field circuit is indicated by a red LED. This module mounts on a HiD Termination Board.

Connection

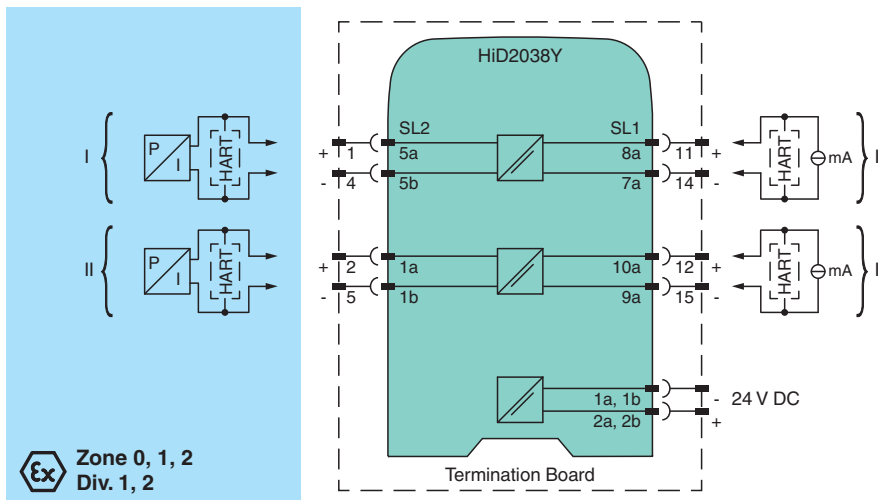

Release date: 2020-07-31 Date of issue: 2020-07-31 Filename: 121543_eng.pdf

Refer to "General Notes Relating to Pepperl+Fuchs Product Information".

Pepperl+Fuchs Group
www.pepperl-fuchs.com

USA: +1 330 486 0002
pa-info@us.pepperl-fuchs.com

Germany: +49 621 776 2222
pa-info@de.pepperl-fuchs.com

Singapore: +65 6779 9091
pa-info@sg.pepperl-fuchs.com

PEPPERL+FUCHS

Dimensions

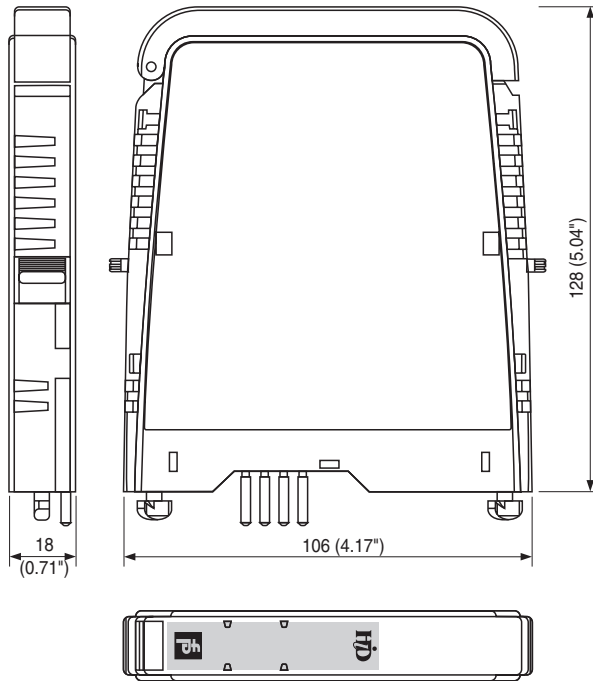

Technical Data

General specifications

Signal type Analog output

Functional safety related parameters

Safety Integrity Level (SIL) SIL 2

Supply

Connection SL1: 1a(-), 1b(-); 2a(+), 2b(+)
 Rated voltage U_r 20.4 ... 30 V DC bus powered via Termination Board
 Rated current I_r 40 mA at 24 V, 20 mA output (per channel)
 Power dissipation 0.85 W at 24 V (per channel)

Input

Connection side control side
 Connection SL1: 8a(+), 7a(-); 10a(+), 9a(-)
 Input current 4 ... 20 mA , reverse polarity protected
 Signal level input voltage drop < 4 V with field wiring intact
 input current < 0.6 mA (47 kΩ) with field wiring open

Output

Connection side field side
 Connection SL2: 5a(+), 5b(-); 1a(+), 1b(-)
 Load 0 ... 750 Ω
 Output signal 4 ... 20 mA
 Ripple 15 mV_{eff}
 Response time 50 ms , 10 ... 90 % step change
 Line fault detection breakage, load > 100 kΩ

Transfer characteristics

Accuracy < ± 0.1 % of full-scale value
 Influence of temperature < ± 0.01 %/K
 Frequency range 0.5 ... 40 kHz within 3 db, (-6 db at 100 kHz) for use with SMART positioners using HART protocol
 Influence of load < ± 0.1 % of full-scale value from 0 ... 750 Ω
 Linearity < ± 0.1 % of full-scale value

Release date: 2020-07-31 Date of issue: 2020-07-31 Filename: 121543_eng.pdf

Technical Data

Galvanic isolation		
Input/power supply		functional insulation acc. to DIN EN 50178, rated insulation voltage 50 V _{eff}
Input/input		functional insulation acc. to DIN EN 50178, rated insulation voltage 50 V _{eff}
Indicators/settings		
Display elements		LEDs
Labeling		space for labeling at the front
Directive conformity		
Electromagnetic compatibility		
Directive 2014/30/EU		EN 61326-1:2013 (industrial locations)
Conformity		
Electromagnetic compatibility		NE 21:2006 For further information see system description.
Degree of protection		IEC 60529
Ambient conditions		
Ambient temperature		-20 ... 60 °C (-4 ... 140 °F)
Relative humidity		5 ... 90 %, non-condensing up to 35 °C (95 °F)
Mechanical specifications		
Degree of protection		IP20
Mass		approx. 140 g
Dimensions		18 x 106 x 128 mm (0.7 x 4.2 x 5 inch)
Mounting		on Termination Board
Coding		pin 1 and 3 trimmed For further information see system description.
Data for application in connection with hazardous areas		
EU-Type Examination Certificate		CESI 02 ATEX 086
Marking		⊕ II (1)G [Ex ia Ga] IIC , ⊕ II (1)D [Ex ia Da] IIIC
Output		Ex ia, Ex iaD
Voltage	U _o	26 V
Current	I _o	93 mA
Power	P _o	605 mW
Supply		
Maximum safe voltage	U _m	250 V AC (Attention! U _m is no rated voltage.)
Certificate		
Marking		⊕ II 3G Ex nA IIC T4 Gc [device in zone 2]
Galvanic isolation		
Input/Output		safe electrical isolation acc. to EN 60079-11: 2007, voltage peak value 375 V
Output/power supply		safe electrical isolation acc. to EN 60079-11: 2007, voltage peak value 375 V
Output/Output		safe electrical isolation acc. to EN 60079-11:2007, voltage peak value 60 V
Directive conformity		
Directive 2014/34/EU		EN 60079-0:2012+A11:2013 , EN 60079-11:2012 , EN 60079-15:2010
International approvals		
CSA approval		
Control drawing		366-005CS-12B (cCSAus)
IECEx approval		
Approved for		[Ex ia] IIC
General information		
Supplementary information		Observe the certificates, declarations of conformity, instruction manuals, and manuals where applicable. For information see www.pepperl-fuchs.com .

Release date: 2020-07-31 Date of issue: 2020-07-31 Filename: 121543_eng.pdf

Assembly

Front view

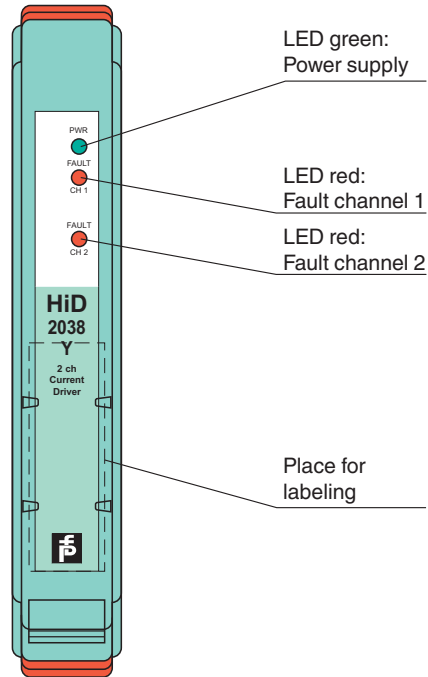

Release date: 2020-07-31 Date of issue: 2020-07-31 Filename: 121543_eng.pdf

Refer to "General Notes Relating to Pepperl+Fuchs Product Information".

Pepperl+Fuchs Group
www.pepperl-fuchs.com

USA: +1 330 486 0002
pa-info@us.pepperl-fuchs.com

Germany: +49 621 776 2222
pa-info@de.pepperl-fuchs.com

Singapore: +65 6779 9091
pa-info@sg.pepperl-fuchs.com

PF PEPPERL+FUCHS

Application

This device is suitable for Yokogawa DCS system. It has reduced current on lead breakage and no fault bus signal.

Configuration

No user configuration available for this device.



*The pins for this device are trimmed to polarize it according to its safety parameter. Do not change!
For further information see system description.*