



# Temperature Converter HiD2082

- 2-channel isolated barrier
- 24 V DC supply (bus powered)
- Thermocouple, RTD or potentiometer input
- Usable as signal splitter (1 input and 2 outputs)
- Linearized output 4 mA ... 20 mA, sink/source or 1 V ... 5 V
- Sensor breakage detection
- Configurable by PACTware
- Line fault detection (LFD)
- Up to SIL 2 acc. to IEC 61508/IEC 61511



## Function

This isolated barrier is used for intrinsic safety applications. This device accepts thermocouples (TC), millivolts, potentiometers, or resistance temperature detectors (RTD) from a hazardous area and converts them to an isolated, linearized analog output in the safe area. The outputs can be selected as a current source, current sink, or voltage source with DIP switches on the side panel. The device can also be configured as a signal splitter. Line fault detection of the field circuit is indicated by a red LED and an output on the fault bus. The fault conditions are monitored via a Fault Indication Board. The device is easily configured by the use of the PACTware configuration software. This device mounts on a HiD Termination Board.

## Connection

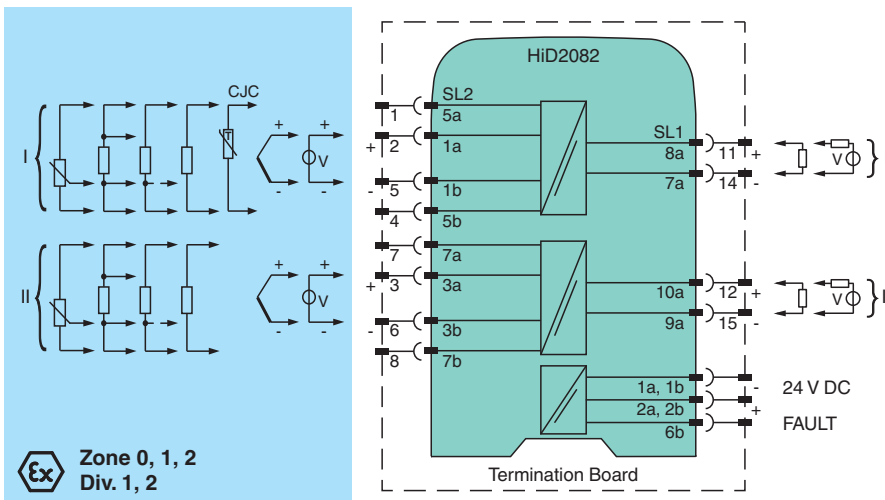

## Technical Data

### General specifications

Signal type	Analog input		
<b>Supply</b>			
Connection	SL1: 1a(-), 1b(-); 2a(+), 2b(+)		
Rated voltage	$U_r$	20.4 ... 30 V DC bus powered via Termination Board	
Ripple	within the supply tolerance		
Current	$\leq 95$ mA at 20.4 V and $\leq 63$ mA at 30 V		
Power consumption	$\leq 1.95$ W		
<b>Interface</b>			

Release date: 2020-11-26 Date of issue: 2020-11-26 Filename: 298204\_eng.pdf

Refer to "General Notes Relating to Pepperl+Fuchs Product Information".

Pepperl+Fuchs Group  
www.pepperl-fuchs.com

USA: +1 330 486 0002  
pa-info@us.pepperl-fuchs.com

Germany: +49 621 776 2222  
pa-info@de.pepperl-fuchs.com

Singapore: +65 6779 9091  
pa-info@sg.pepperl-fuchs.com

**PEPPERL+FUCHS**

## Technical Data

Programming interface	programming socket
<b>Input</b>	
Connection side	field side
Connection	SL2: 5a(+), 1a(+), 1b(-), 5b(-); 7a(+), 3a(+), 3b(-), 7b(-)
RTD	type Cu10, Cu50, Cu100, Pt10, Pt50, Pt100, Pt500, Pt1000, Ni100 (EN 60751: 1995) type Pt10GOST, Pt50GOST, Pt100GOST, Pt50GOST, Pt1000GOST (P50353-92)
Measuring current	approx. 200 µA with RTD
Types of measuring	2-, 3-, 4-wire connection
Lead resistance	max. 50 Ω per line
Measurement loop monitoring	sensor breakage, sensor short-circuit
Thermocouples	type B, E, J, K, N, R, S, T (IEC 584-1: 1995) type L (DIN 43710: 1985) type TXK, TXKH, TXA (P8.585-2001)
Cold junction compensation	at field terminals
Measurement loop monitoring	sensor breakage
Potentiometer	0.1 ... 20 kΩ
Types of measuring	3-wire connection
Voltage	selectable within the range -100 ... 100 mV
Input resistance	min. 1 MΩ (-100 ... 100 mV)
<b>Output</b>	
Connection side	control side
Connection	SL1: 8a(+), 7a(-); 10a(+), 9a(-)
Output I, II	analog, current or voltage output
Current range	0/4 ... 20 mA
Voltage range	0 ... 5 V or 1 ... 5 V (on 250 Ω, 0.1 % internal shunt)
Fault signal	downscale 0 or 2 mA, upscale 21.5 mA (acc. NAMUR NE43)
Source	load 0 ... 550 Ω, open-circuit voltage ≤ 18 V
Sink	Voltage across terminals 7 ... 30 V. If the current is supplied from a source > 20 V, series resistance of $\geq (V - 20)/0.0215 \Omega$ is needed, where V is the source voltage. The maximum value of the resistance is $(V - 7)/0.0215 \Omega$ .
<b>Fault indication output</b>	
Connection	SL1: 6b
Output type	open collector transistor (internal fault bus)
<b>Transfer characteristics</b>	
Deviation	
After calibration	Pt100: $\pm (0.05 \% \text{ of measurement value in } ^\circ\text{C} + 0.05 \% \text{ of span} + 0.1 \text{ K (4-wire connection)})$ thermocouple: $\pm (0.05 \% \text{ of measurement value in } ^\circ\text{C} + 0.05 \% \text{ of span} + 1 \text{ K (1.2 K for types R and S)})$ This includes $\pm 0.8 \text{ K}$ error of the cold junction compensation
Influence of ambient temperature	current output (deviation of CJC included): Pt100: $\pm (0.0015 \% \text{ of measurement value in K} + 0.006 \% \text{ of span})/K \Delta T_{\text{amb}}^{\text{)}})$ thermocouple: $\pm (0.02 \text{ K} + 0.01 \% \text{ of measurement value in K} + 0.006 \% \text{ of span})/K \Delta T_{\text{amb}}^{\text{)}})$ $\Delta T_{\text{amb}}^{\text{)}} = \text{ambient temperature change referenced to } 23 \text{ } ^\circ\text{C (296 K)}$
Influence of supply voltage	< 0.01 % of span
Influence of load	≤ 0.1% of full scale from 0 ... 550 Ω
Reaction time	worst case value (sensor breakage and/or sensor short circuit detection enabled) mV: 1.2 s, thermocouples with CJC: 1.4 s, thermocouples with fixed ref. temp: 1.4 s, 3- or 4-wire RTD: 1.1 s, 2-wire RTD: 920 ms
<b>Galvanic isolation</b>	
Power supply/programming input	There is no electrical isolation between the programming input and the supply. The programming cable provides galvanic isolation so that ground loops are avoided.
<b>Indicators/settings</b>	
Display elements	LEDs
Control elements	DIP-switch
Configuration	via DIP switches via PACTware
Labeling	space for labeling at the front

Release date: 2020-11-26 Date of issue: 2020-11-26 Filename: 298204\_eng.pdf

## Technical Data

<b>Directive conformity</b>		
Electromagnetic compatibility		
Directive 2014/30/EU		EN 61326-1:2013 (industrial locations)
<b>Conformity</b>		
Electromagnetic compatibility		NE 21:2006 For further information see system description.
Degree of protection		IEC 60529:2001
<b>Ambient conditions</b>		
Ambient temperature		-20 ... 60 °C (-4 ... 140 °F)
Relative humidity		5 ... 90 %, non-condensing up to 35 °C (95 °F)
<b>Mechanical specifications</b>		
Degree of protection		IP20
Mass		approx. 140 g
Dimensions		18 x 106 x 128 mm (0.7 x 4.2 x 5 inch)
Mounting		on Termination Board
Coding		pin 2 and 4 trimmed For further information see system description.
<b>Data for application in connection with hazardous areas</b>		
EU-type examination certificate		CESI 02 ATEX 086
Marking		⊕ II (1)G [Ex ia Ga] IIC ⊕ II (1)D [Ex ia Da] IIIC , (-20 °C ≤ T <sub>amb</sub> ≤ 60 °C)
Input		[Ex ia Ga] IIC, [Ex ia Da] IIIC
Voltage	U <sub>o</sub>	10 V
Current	I <sub>o</sub>	15 mA
Power	P <sub>o</sub>	38 mW
Analog outputs, power supply, collective error		
Maximum safe voltage	U <sub>m</sub>	250 V (Attention! This is not the rated voltage.)
Interface		
Maximum safe voltage	U <sub>m</sub>	250 V (Attention! The rated voltage is lower.), RS 232
Certificate		
Marking		⊕ II 3G Ex nA nC IIC T4
Galvanic isolation		
Input/input		125 V AC max. common voltage between isolated channels (mV or thermocouple inputs only)
Input/Output		safe electrical isolation acc. to IEC/EN 60079-11, voltage peak value 375 V
Input/power supply		safe electrical isolation acc. to IEC/EN 60079-11, voltage peak value 375 V
Input/Programming input		safe electrical isolation acc. to IEC/EN 60079-11, voltage peak value 375 V
Directive conformity		
Directive 2014/34/EU		EN 60079-0:2012+A11:2013 , EN 60079-11:2012 , EN 60079-15:2010
<b>International approvals</b>		
CSA approval		
Control drawing		366-017CS-12 (cCSAus)
IECEx approval		
Approved for		[Ex ia] IIC
<b>General information</b>		
Supplementary information		Observe the certificates, declarations of conformity, instruction manuals, and manuals where applicable. For information see <a href="http://www.pepperl-fuchs.com">www.pepperl-fuchs.com</a> .
<b>Accessories</b>		
Designation		optional accessories: - resistance thermometer for cold junction compensation H-CJC-SP-8 - adapter with USB Interface K-ADP-USB

Release date: 2020-11-26 Date of issue: 2020-11-26 Filename: 298204\_eng.pdf

Refer to "General Notes Relating to Pepperl+Fuchs Product Information".

Pepperl+Fuchs Group  
[www.pepperl-fuchs.com](http://www.pepperl-fuchs.com)USA: +1 330 486 0002  
pa-info@us.pepperl-fuchs.comGermany: +49 621 776 2222  
pa-info@de.pepperl-fuchs.comSingapore: +65 6779 9091  
pa-info@sg.pepperl-fuchs.com
 PEPPERL+FUCHS

Front view

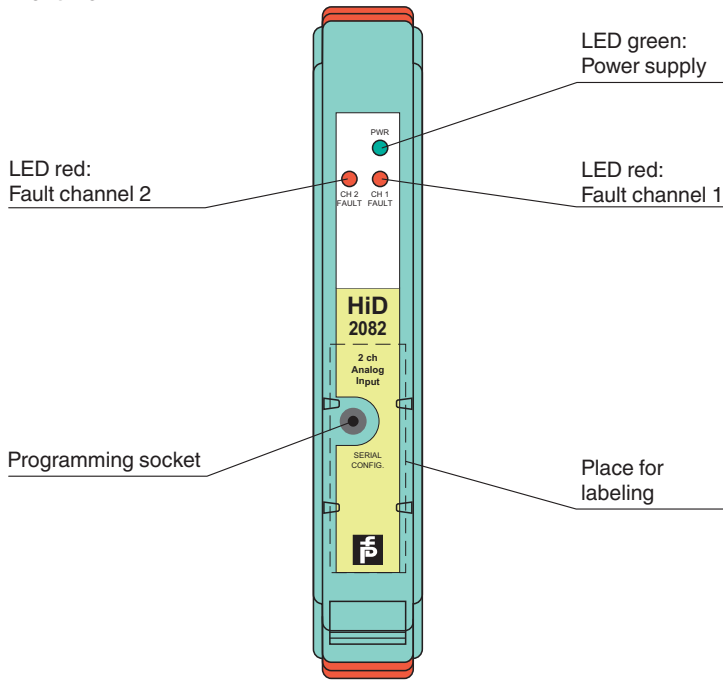

Matching System Components

	<b>HiDTB08-HON-DA16-SD37-PL</b>	
--	---------------------------------	--

Accessories

	<b>H-CJC-SP-8</b>	
	<b>H-CJC-SC-8</b>	
	<b>DTM Interface Technology</b>	
	<b>PACTware 5.X</b>	FDT Framework
	<b>K-ADP-USB</b>	

Release date: 2020-11-26 Date of issue: 2020-11-26 Filename: 298204\_eng.pdf

## Application

The resistance thermometer for cold junction compensation H-CJC-\*\*-8 is available as an accessory for temperature measurements with thermocouples.

## Configuration

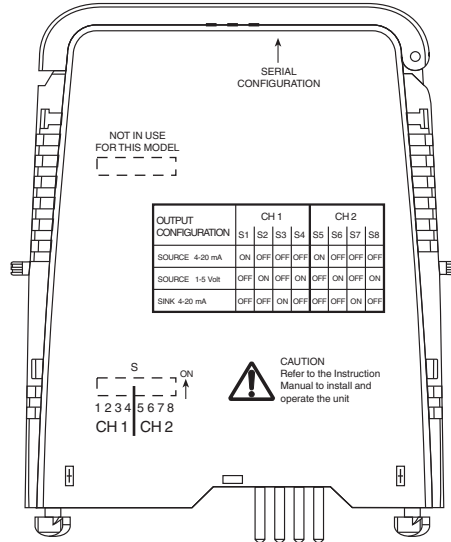

### Switch position

Channel	Switch	Function		
		Source 4 mA ... 20 mA	Source 1 V ... 5 V	Sink 4 mA ... 20 mA
I	S1	ON	OFF	OFF
	S2	OFF	ON	OFF
	S3	OFF	OFF	ON
	S4	OFF	ON	OFF
II	S5	ON	OFF	OFF
	S6	OFF	ON	OFF
	S7	OFF	OFF	ON
	S8	OFF	ON	OFF

## Configuration

Configure the device in the following way:

- Push the red Quick Lok Bars on each side of the device in the upper position.
- Remove the device from Termination Board.
- Set the DIP switches according to the figure.



*The pins for this device are trimmed to polarize it according to its safety parameter. Do not change! For further information see system description.*

Release date: 2020-11-26 Date of issue: 2020-11-26 Filename: 298204\_eng.pdf

Refer to "General Notes Relating to Pepperl+Fuchs Product Information".