

PARAMETERS SETTING

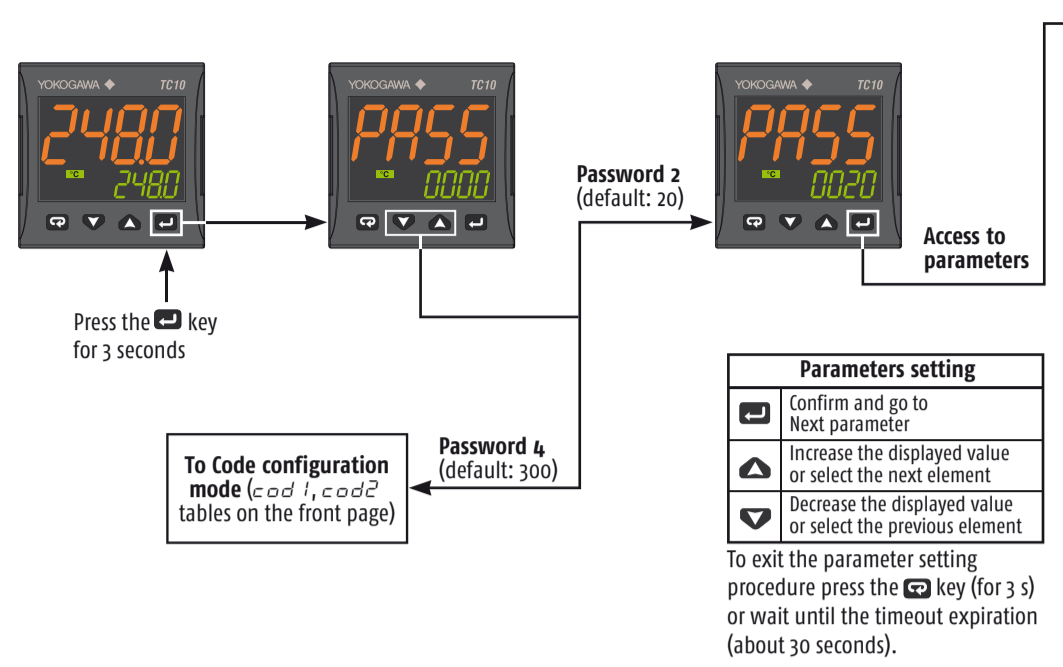

CONTROLLER OPERATION

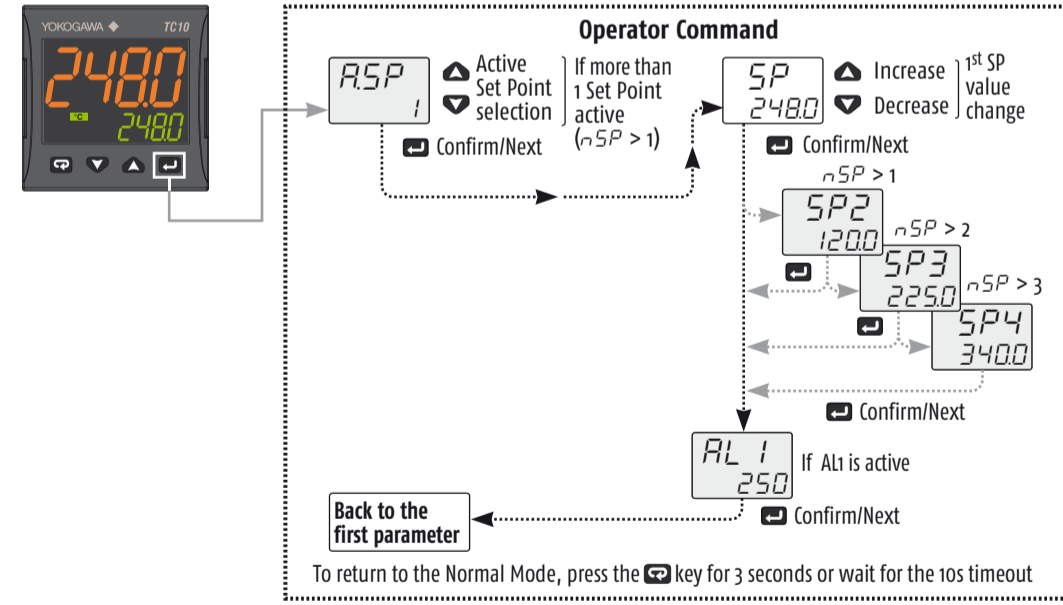
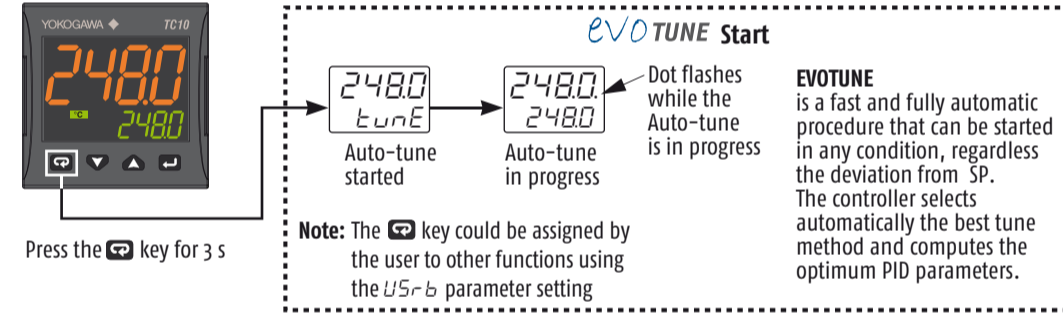
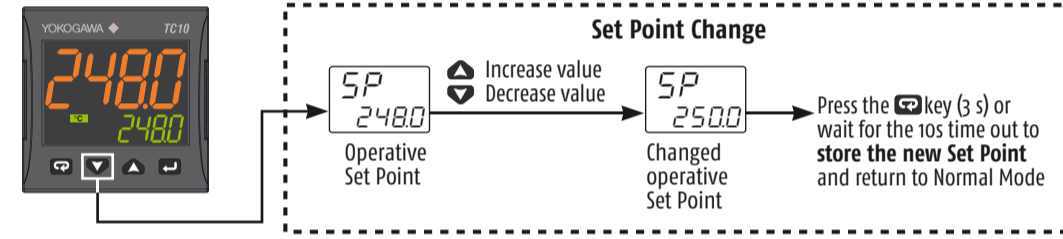
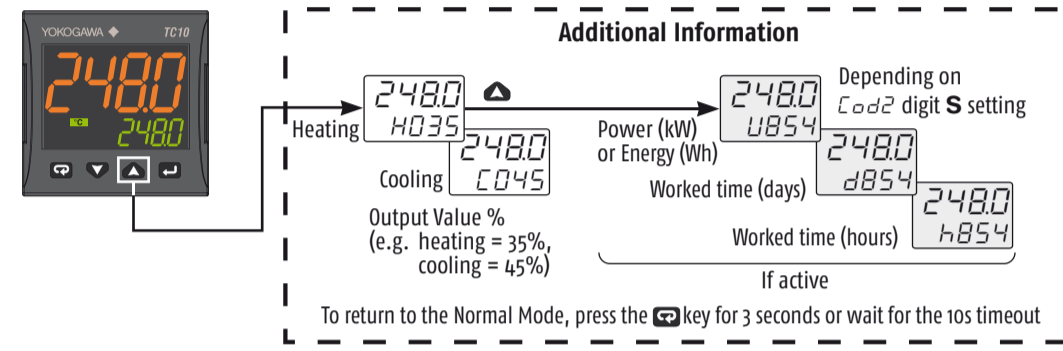

Parameters List (PASS : 20)

(Parameters of RS485 Modbus Serial Communications are shown in gray cells in the below table)

Group	Param.	Description	Range value or selection list elements	Default	User value	Note
Commands	oPEr	Operative Mode Selection	auto = Auto; oplo = Manual; stdy = Standby			
	RSP	Set Point Selection	0 = SP, 1 = SP2, 2 = SP3, 3 = SP4	0 = SP		
	tunE	Start Auto Tune	0 = OFF, 1 = start	0 = OFF		evoTUNE
Control	Pb	Proportional Band	1 to 9999 (Engineering Units = E.U.)	50		
	tI	Integral Time	0 to 10000 s	200		Cod1 Digit N = 1
	tD	Derivative Time	0 to 9999 s	50		
	HSEt	Hysteresis ON/OFF Control	0 to 9999 (E.U.)	1		Cod1 Digit N = 0
	tCH	Heating output cycle time	0.1 to 130 s	20.0		Cod1 Digit N = 1
	rCO	Relative Cooling Gain	0.01 to 99.99	1.00		Cod1 Digit N = 1 Cod1 Digit O > 4
	tCC	Cooling output cycle time	0.1 to 130 s	20.0		Cod1 Digit N = 1 Cod1 Digit O > 1
Set Point	SP	Set Point 1	-1999 to +9999 (E.U.)			
	SP2	Set Point 2				If nSP > 1
	SP3	Set Point 3				If nSP > 2
	SP4	Set Point 4				If nSP > 3
	SPLL	Set Point min. Value	-1999 to SPHL (E.U.)			
	SPHL	Set Point max. Value	SPLL to 9999 (E.U.)			
Alarms	nSP	No. of Set Points	1 to 4	1		
	AL1	Alarm 1 threshold	AL1L to AL1H			
	AL1L	Alarm 1 low threshold/Low limit		-1999		If digit P of Cod2 is > 1
	AL1H	Alarm 1 high threshold/High limit		9999		
	HAL1	AL1 hysteresis	1 to 9999 (E.U.)	1		
	AL2	Alarm 2 threshold	AL2L to AL2H			
	AL2L	Alarm 2 low threshold/Low limit		-1999		If digit Q of Cod2 is > 1
	AL2H	Alarm 2 high threshold/High limit		9999		
	HAL2	AL2 hysteresis	1 to 9999 (E.U.)	1		
Soft Start	AL3	Alarm 3 threshold	AL3L to AL3H			
	AL3L	Alarm 3 low threshold/Low limit		-1999		If digit R of Cod2 is > 1
	AL3H	Alarm 3 high threshold/High limit		9999		
	HAL3	AL3 hysteresis	1 to 9999 (E.U.)	1		
	SSP	Soft Start Output value	-100 to 100%	0		
	SSt	Soft Start Time	0.00 to 8.00 (hh.mm)	0		
Input	SSc	Low Scale readout	-1999 to 9999	-1999		For linear Input types only
	FSc	High Scale readout	-1999 to 9999	9999		
	dP	Number of decimals	0 to 3 (linear inputs); 0 to 1 (other inputs)	0		
I/O	FIL	Measured value Digital filter	OFF; 0.1 to 20.0 s	1.0		
	IO4F	I/O 4 Function	ON = Transmitter Power Supply; OUT4 = SSR out; Di2C = Dig. In. from contact; Di2U = 24 VDC Digital Input;	OUT4		
Digital Inputs	dIF1	Digital Input 1 Function	0 to 21	0		See the DI1, DI2 functions table
	dIF2	Digital Input 2 Function	0 to 21	0		
	dIA	Digital Inputs Action	0 = Dh direct action, DI2 direct action; 1 = Dh reverse action, DI2 direct action; 2 = Dh direct action, DI2 reverse action; 3 = Dh reverse action, DI2 reverse action.	0		DI2 only if configured
Display	uSrb	Key Function	nonE, tunE, oplo, aac, asi, chsp, st.by, str.t	tunE		See the Key function table
	dICL	Color of the Process Value display	0 = Change 1 = Red 2 = Green 3 = Orange	2		If Change, the color is green if PV differs from SP less than AdE, red if higher than AdE and orange if is lower than AdE
	AdE	Display change color threshold (when dICL = 0)	0 (OFF) to 9999 (e.u.)			
Serial communications	dISL	Display Power OFF time (mm.ss)	oFF (display ON) 0.1 to 99.59	oFF		
	Addr	Instrument Address	1 to 254	1		Modbus RTU slave protocol
Wattmeter	bAud	Baud rate	1200, 2400, 9600 baud, 19.2, 38.4 kbaud	9600		
	VolE	Load Voltage	1 to 999 (V)	230		If digit S of Cod2 is > 1
Password	cur	Load Current	1 to 9999 (A)			
	PAS4	Configuration access Password	201 to 400	300		
	PAS2	Parameters access Password	0 to 200	20		

Note: To access all the instrument features, please see the "Complete configuration procedure" in the "Engineering Manual".

dIF - Digital Inputs DI1 and DI2 Functions

Code displayed	Description
0	Disabled (OFF) (default)
1	Alarm Reset
2	Alarm Acknowledge (ACK)
3	Hold of the measured value
4	Stand by mode
5	Manual Mode
6	Heat with "SP" and Cool with "SP2"
7 to 17	Reserved
18	Sequential Set Point selection [on transition]
19	SP/SP2 selection
20	Binary coding for Set Point selection on DI1 and DI2 (00 = SP, 01 = SP2, 10 = SP3, 11 = SP4)
21	Digital inputs in parallel to the UP and Down keys (DI1 = UP key, DI2 = DOWN key)

uSrb Key Function

Code displayed	Description
nonE	Not used
tunE	Starts auto tuning functions (default)
oPLo	Manual mode
ARc	Alarm Reset
ASi	Alarm Acknowledge
chSP	Circular Set Point Selection (shows SP, SP2, SP3)
StBy	Stand-by mode

关于产品污染防止管理

Control of Pollution Caused by the Product

根据中华人民共和国电子信息产品的防污染管理办法，对本仪表进行说明。

This is an explanation for the product based on "Control of pollution caused by Electronic Information Products" in the People's Republic of China.

产品中有毒有害物质或元素的名称及含量

部件名称	有毒有害物质或元素					
	铅(Pb)	汞(Hg)	镉(Cd)	六价铬(Cr6+)	多溴联苯(PBB)	多溴二苯醚(PBDB)
框架 (塑料)	×	×	×	○	○	○
框架 (金属)	×	×	×	○	○	○
内部接线材料	×	×	×	○	○	○
电源	×	×	×	○	○	○

○ : 表示该部件所有基材中所含的有毒有害物质含量均未超过GB/T26572标准中规定的限量要求。
 × : 表示该部件中至少有一种基材中所含的有毒有害物质含量超过GB/T26572标准所规定的限量要求。



DISPOSAL
 The appliance (or the product) must be disposed of separately in compliance with the local standards in force on waste disposal.

Note: Some parts of this product include the restricted substances of RoHS Directive, but their applications are under the exemption of the directive.



该标志为环境保护使用期限，根据SJ/T11364，适用于在中国(台湾、香港、澳门除外)销售的电子电气产品。只要遵守该产品的安全及使用注意事项，从产品生产之日起至该标志所示年限内，不会因为产品中的有害物质外泄或突变而导致环境污染或对人体财产产生重大影响。(注释) 该标志所示年限为“环境保护使用期限”，并非产品的保质期。另外，关于更换部件的推荐更换周期，请参阅使用说明书。