

# 6888 in-Situ Combustion O<sub>2</sub> Analyzer



# Contents

## Section 1: General Information

Essential Instructions .....	4
Overview .....	6
System Configurations	
Transmitter Probe, Only .....	6
Standard Housing Transmitter Probe plus 6888Xi Electronics .....	6
Transmitter Probe and 6888Xi with Flame Safety Interlock.....	7
Transmitter Probe w/Integral Autocal, 6888Xi, and HART Communications .....	7
Transmitter Probe w/Integral Autocal and FOUNDATION Fieldbus (FF) Communications .....	7
Direct Replacement (DR) Probe, w/Traditional Architecture 6888Xi Electronics .....	7
Wireless Capability .....	7

## Section 2: Typical System Package

Technical Support Hotline .....	8
---------------------------------	---

## Section 3: 6888A Product Matrix

6888A O <sub>2</sub> Transmitter .....	9
6888Xi Advanced Electronics .....	11

## Section 4: Specifications

Transmitter/DR Probe	
Measurement Specifications .....	12
Environmental Specifications .....	12
6888Xi	
Measurement Specifications .....	12
Installation Specifications Xi with Transmitter Probe .....	14
Installation Specifications for Traditional Architecture Xi for use with DR or other Probe .....	15

## Section 5: Installation

Mechanical installation	
6888A Probe Installation .....	16
Drip Loop and Insulation Removal .....	20
6888Xi Advanced Electronics .....	21
Wall/Surface and Pipe Mount .....	22
Panel Mount .....	23
Electrical	
Wiring for 6888 Transmitter Probe only (no Xi Electronics) .....	25
Standard Housing Transmitter Probe plus 6888Xi Electronics .....	27
Transmitter Probe w/Single-channel Xi and Flame Safety Interlock .....	30
Transmitter Probe w/Integral Autocal and HART communications .....	34
Transmitter Probe w/Integral Autocal and FOUNDATION Fieldbus communications .....	38
Traditional Architecture System w/Direct Replacement Probe (no Electronics inside) .....	42
Existing Yokogawa Electronics.....	46
Traditional Architecture Cable Connections .....	48

# Contents

<b>Section 7: Pneumatic Installation</b>	
Reference Air Package .....	50
<b>Section 8: Power Up Procedures</b>	
6888 Transmitter without 6888Xi .....	51
6888 Transmitter w/Single/Dual Channel or Single Channel & Flame Safety Interlock 6888Xi.....	52
6888 Direct Replacement Probe (no Electronics inside) w/Traditional Architecture 6888Xi.....	52
6888Xi Quick Start Wizard .....	53
Re-initiating 6888Xi Wizard.....	53
<b>Section 9: Calibration</b>	
6888 O <sub>2</sub> Analyzer.....	54
<b>Section 10: Menu Trees</b>	
HART 6888Xi.....	58
HART 375/475 Communicator.....	64
FOUNDATION Fieldbus 6888Xi.....	68
FOUNDATION Fieldbus 375/475 Communicator .....	74
<b>Section 11: Safety Data</b>	
Safety Data.....	82
<b>Section 12: Return of Material</b>	
Returning Material .....	83
<b>Section 13: EC Declaration of Conformity</b>	
Returning Material .....	84

# Essential Instructions

## Read this page before proceeding

Emerson Process Management designs, manufactures and tests its products to meet many national and international standards. Because these instruments are sophisticated technical products, you **MUST** properly install, use, and maintain them to ensure they continue to operate with-in their normal specifications. The following instructions **MUST** be adhered to and integrated into your safety program when installing, using, and maintaining Rosemount Analytical products. Failure to follow the proper instructions may cause any one of the following situations to occur: Loss of life; personal injury; property damage; damage to this instrument; and warranty invalidation.

- Read all instructions prior to installing, operating, and servicing the product.
- If you do not understand any of the instructions, contact your Emerson Process Management representative for clarification.
- Follow all warnings, cautions, and instructions marked on and supplied with the product.
- Inform and educate your personnel in the proper installation, operation, and maintenance of the product.
- Install your equipment as specified in the Installation Instructions of the appropriate Instruction Manual and per applicable local and national codes. Connect all products to the proper electrical and pressure sources.
- To ensure proper performance, use qualified personnel to install, operate, update, program, and maintain the product.

### NOTICE

This manual concentrates on the installation, start-up, calibration, and operation of this product. There is also a more comprehensive manual that also covers troubleshooting, maintenance, repair, and spare parts identification.

- When replacement parts are required, ensure that qualified people use replacement parts specified by Emerson Process Management. Unauthorized parts and procedures can affect the product's performance, place the safe operation of your process at risk, and **VOID YOUR WARRANTY**. Look-alike substitutions may result in fire, electrical hazards, or improper operation.
- Ensure that all equipment doors are closed and protective covers are in place, except when maintenance is being performed by qualified persons, to prevent electrical shock and personal injury. The information contained in this document is subject to change without notice.





The information contained in this document is subject to change without notice.

### NOTICE

The 375 Field Communicator must be upgraded to System Software 2.0 with Graphic License for operation with the 6888A O2 Transmitter. The AMS software must be upgraded to AMS 8.0 or above. Contact Emerson Process Management's Global Service Center (GSC) at 1-800-833-8314 to upgrade the 375 Field Communicator software to System Software 2.0 with Graphic License.

# Essential Instructions

## Symbols

-  : EARTH (GROUND) TERMINAL
-  : PROTECTIVE CONDUCT OR TERMINAL
-  : RISK OF ELECTRICAL SHOCK
-  : WARNING: REFER TO INSTRUCTION MANUAL

**Note:** If the equipment is used in a manner not specified by the manufacturer, the protection provided by the equipment may be impaired.

## Definitions

The following definitions apply to WARNINGS, CAUTIONS, and NOTES found throughout this publication.

### **WARNING**

Highlights an operation or maintenance procedure, practice, condition, statement, etc. If not strictly observed, could result in injury, death, or long-term health hazards of personnel.

### **CAUTION**

Highlights an operation or maintenance procedure, practice, condition, statement, etc. If not strictly observed, could result in damage to or destruction of equipment, or loss of effectiveness.

### **NOTICE**

Highlights an essential operating procedure, condition, or statement.

# General Information

## Overview

The 6888 is Rosemount Analytical's latest combustion flue gas oxygen analyzer. This product is intended for measuring the flue gases resulting from any combustion process. It utilizes the same heated sensing technology as the O<sub>2</sub> sensors found in most automobiles. Contact Rosemount Analytical's technical support group at 800-433-6076 for any applications other than measuring combustion flue (exhaust) gases.

This product utilizes an "in situ" sensor, i.e. the sensor is placed at the end of a probe, and the probe extends directly into the flue gas duct or stack at a given length. The sensor is like a thermocouple, generating its own millivolt signal based on the difference between a reference gas (ambient or instrument air – always 20.95% O<sub>2</sub>), and the flue gases being measured. There are several different arrangements of probes, electronics, and features that are explained below, and in the wiring diagrams.

An optional 6888 Xi with HART communications provides convenient operator interface for set-up, calibration, and diagnostics. HART communications is still present when using the 6888Xi.

## System Configurations

### Transmitter Probe, Only

The 6888 probe has the electronics in the blue housing that controls the heater temperature, and also amplifies the raw O<sub>2</sub> millivolt signal to a linear 4-20 mA. The 4-20 mA signal lines can be run directly to the control room, and also powers the transmitter electronics. As with most other Rosemount transmitters measuring pressure, temperature, and flow, set-up is conducted through HART communications via a 475 handheld communicator, or via Asset Management Solutions (AMS).

### Standard Housing Transmitter Probe plus 6888Xi Electronics

The 6888Xi electronics serve as a local operator interface unit, with a back-lit display and keypad. It is capable of two channels, serving two 6888 probes. The 6888Xi also carries these optional advanced features:

- Fully automatic calibration. Requires Xi O<sub>2</sub> Cal Auto calibration system.
- Loss-of flame contact for powering down the heater in the event of a flame-out condition in a furnace.
- Heaterless operation at process temperatures above 550°C. This feature will also permit operation above the heater set point of 736°C. Sensing cell life will be shortened by operation above 800°C, however.
- Plugged diffuser diagnostic operates by measuring the return-to-process rate after calibration gas has been stopped. This feature also includes auto gas switching when the reading settles out versus waiting for configured gas flow time to expire.
- Stoichiometer – If a furnace goes into a reducing condition (zero % O<sub>2</sub>), this feature will determine how far.
- Programmable reference – Permits more accurate readings at near-ambient O<sub>2</sub> levels (20.95% O<sub>2</sub>).

## General Information

### Standard Housing Transmitter Probe plus 6888Xi Electronics

- A “cal check” capability. New calibration values are not automatically stored after a calibration. An accept/reject calibration feature can be enabled or disabled so that the technician or operator can decide to accept or reject a potentially large change in calibration values.
- Tolerance Check that will alarm if the wrong test gases are being used, or if a bottle runs out in the middle of a calibration. Care must be taken to ensure gas 1 and gas 2 calibration gases are properly configured if the tolerance check feature is enabled.

### Transmitter Probe and 6888Xi with Flame safety interlock

A flame safety interlock by Emerson Process Management is available for heater power disconnect whenever there is a loss of the process flame or a heater runaway condition (heater over-temperature) in the O<sub>2</sub> Probe. This input is internally powered by the 6888Xi and is actuated via a dry contact output from the user’s flame scanner. A closed contact indicates a flame is present. An open contact indicates a loss of flame. This feature is also available with the Integral autocal housing.

### Transmitter Probe with Integral Autocal, 6888Xi, and HART communications

This probe contains gas-switching solenoids so that the 6888Xi electronics can control the introduction of calibration gases. Calibrations can be initiated via a calibration recommended diagnostic, time since last calibration, manually via external dry contact, HART communications, or from the 6888Xi local operator interface keypad. The integral autocal feature can only be implemented when the probe is used with a 6888Xi.

### Transmitter Probe with Integral Autocal and FOUNDATION Fieldbus (FF) communications

This probe contains gas-switching solenoids that can control the introduction of calibration gases for calibration. Calibrations can be initiated automatically via a calibration recommended diagnostic, time since last calibration, or manually via optional Xi keypad, FF communications via the 475 communicator, or AMS console. Unlike the HART transmitter electronics, the FF version can execute automatic calibrations either with or without the optional 6888 Xi electronics. Likewise, advanced features can be implemented either with or without the optional Xi.

### Direct Replacement (DR) Probe, with Traditional Architecture 6888Xi electronics

Here there are no electronics inside the probe head, so the raw sensor signals for the heater thermocouple and zirconium oxide O<sub>2</sub> sensor are sent to a remote 6888Xi Electronics. The 6888 Traditional Architecture electronics will also directly apply power to the probe heater in order to maintain the correct sensor temperature. This arrangement calls for a 7- conductor cable to carry this power and the sensor signals. Maximum length for this cable is 200 feet. This probe will also operate on previous Westinghouse/Rosemount electronics (World Class and Oxymitter), as well as many competitive electronics.

### Wireless Capability

It should be noted that both the transmitter electronics in the head of the probe and the 6888Xi electronics communicate over HART communications, and can implement wireless communications via our Smart Wireless THUM adapter.

## Typical System Package

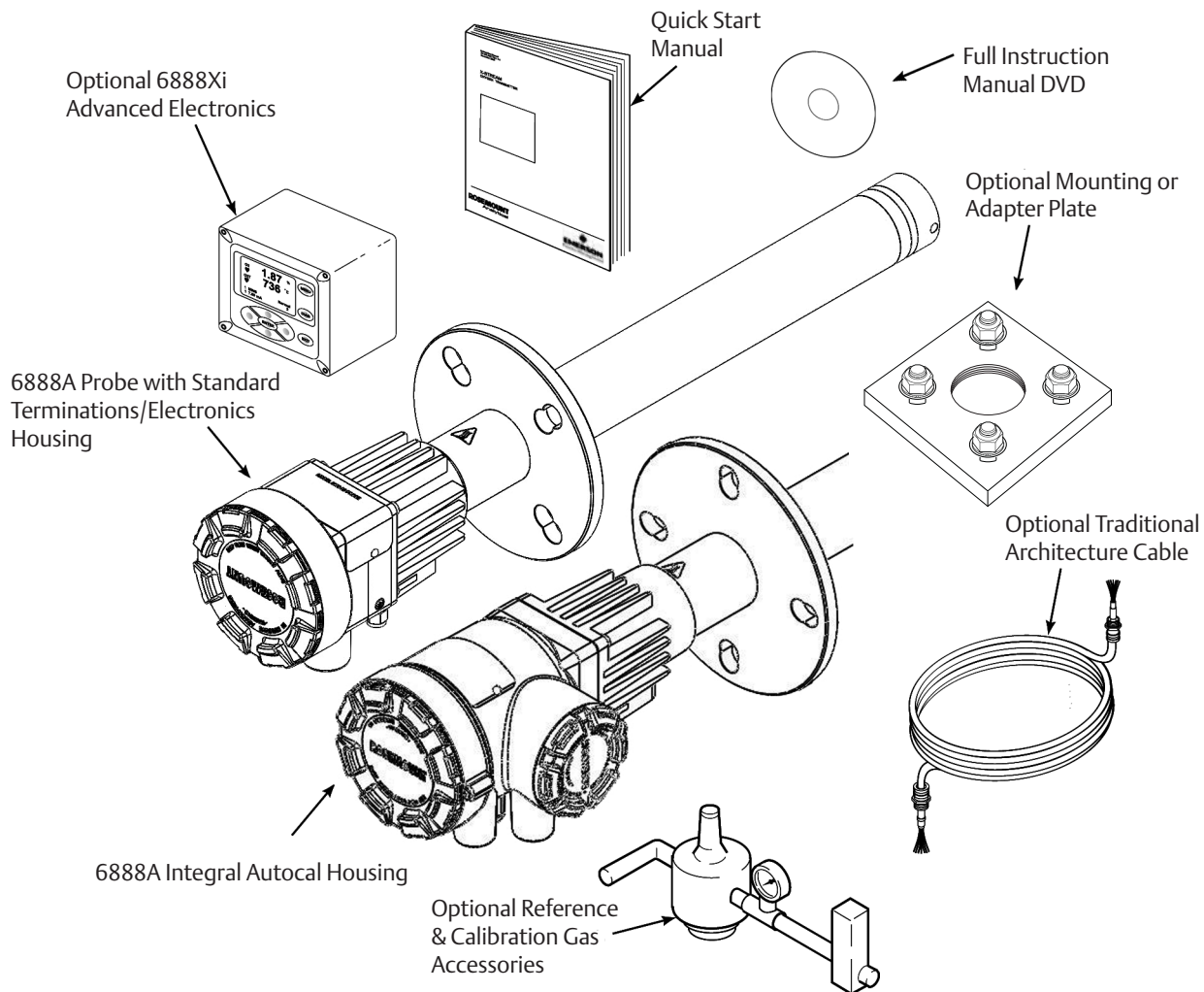

### Technical Support Hotline

For assistance with technical problems, please call the Customer Support Center (CSC).

- 1-RAI-AND-U (1-855-724-2638)
- 1-440-914-1261

In addition to the CSC, you may also contact Field Watch. Field Watch coordinates Emerson Process Management's field service throughout the U.S. and abroad.

- 1-800-654-RSMT (1-800-654-7768)

Emerson Process Management may also be reached via the Internet through e-mail and the World Wide Web

- e-mail: [GAS.CSC@emerson.com](mailto:GAS.CSC@emerson.com)
- World Wide Web: [www.raihome.com](http://www.raihome.com)

## 6888A Product Matrix

Compare the configuration matrix below to the model number on the probe tag to confirm the features present in this specific probe.

Model	Description
6888A	O <sub>2</sub> Transmitter
<b>Measurement</b>	
1OXY	Oxygen, Standard Sensing Cell
2OXY	Oxygen, Acid Resistant Stoichiometric Sensing Cell
<b>Probe Length *</b>	
1	18" Probe, Standard Probe Tube
2	18" Probe, Standard Probe Tube with Abrasive Shield
3	18" Probe, Abrasion Resistant Probe Tube
4	3' Probe, Standard Probe Tube
5	3' Probe, Standard Probe Tube with Abrasive Shield
6	3' Probe, Abrasion Resistant Probe Tube
7	6' Probe, Standard Probe Tube
8	6' Probe, Standard Probe Tube with Abrasive Shield
9	6' Probe, Abrasion Resistant Probe Tube
A	9' Probe, Abrasion Resistant Probe Tube
AA	9' Probe, Abrasion Resistant Probe Tube with Abrasive Shield
B	12' Probe, Abrasion Resistant Probe Tube
BA	12' Probe, Abrasion Resistant Probe Tube with Abrasive Shield
<b>Diffuser</b>	
1	Snubber 400°C (752°F)
1A	Snubber with dust shield 400°C (752°F) (Used with Abrasive Shield)
1F	Snubber with Flashback Arrestor 400°C (752°F)
2	Ceramic 825°C (1517°F)
2A	Ceramic with dust shield 825°C (1517°F) (Used with Abrasive Shield)
2F	Ceramic (825°C) with Flashback Arrestor 825°C (1517°F)
3	Hastelloy 40 um 705°C (1292°F)
3A	Hastelloy with dust seal 40 um 705°C (1292°F) (Used with Abrasive Shields)
<b>Housing &amp; Electronics</b>	
1HT	Standard Housing, Transmitter Electronics, HART Communications
2HT	Integral Autocal, Transmitter Electronics, HART Communications
4FF	Integral Autocal, Transmitter Electronics, Fieldbus Communications
5DR	Standard Housing, Direct Replacement, No Electronics
6DRY	Standard Housing, Direct Replacement, YEW Electronics

\* Probes supplied with flanges with dual ANSI/DIN hole pattern. See Figure 3 for details.

## 6888A Product Matrix (continued)

Compare the configuration matrix below to the model number on the probe tag to confirm the features present in this specific probe.

<b>Mounting Plate</b>	
00	None
04	New Installation - Square Weld Plate with ANSI 2" - 150# Studs & Flange (2.5" process hole required)
05	New Installation - Square Weld Plate with DIN Studs & Flange (2.5" process hole required)
06	New Installation - Variable Insertion Mount; Abrasion Resistant Probe Only
07	New Installation - Variable Insertion Mount; Mounted to Existing OXT/WC Abrasive Shield Mounts; Abrasion Resistant Probe Only
08	Adapter to Existing ANSI 3", 150# Flange
09	Adapter to Existing ANSI 4", 150# Flange
10	Adapter to Existing ANSI 6", 150# Flange
11	Adapter to Existing ANSI 3", 300# Flange
12	Adapter to Existing ANSI 4", 300# Flange
99	Special Adapter - provide existing flange dimensions, including thru-hole diameter
<b>Manual Calibration Accessories</b>	
00	None
01	Calibration & Reference Gas Flowmeters & Reference Regulator/Filter Diffuser
02	Calibration/Reference Panel
<b>Stoichiometer Function - FOUNDATION Fieldbus only (For HART versions, order this feature with 6888 Xi electronics)</b>	
0	No
1	Yes
<b>Programmable Reference Function - FOUNDATION Fieldbus only (For HART versions, order this feature with 6888 Xi electronics)</b>	
0	No
1	Yes
<b>Extended Temperature Reference Function - FOUNDATION Fieldbus only (For HART versions, order this feature with 6888 Xi electronics)</b>	
0	No
1	Yes
<b>Diffuser Warning Function - FOUNDATION Fieldbus only (For HART versions, order this feature with 6888 Xi electronics)</b>	
0	No
1	Yes

## 6888Xi Product Matrix

Compare the configuration matrix below to the model number on the probe tag to confirm the features present in this specific probe.

Model	Product Description
6888Xi	Advanced Electronics
<b>Remote Type</b>	
1OXY	Single Channel O <sub>2</sub>
2OXY	Single Channel O <sub>2</sub> with Flame Safety Interlock for Heater
3OXY	Dual Channel O <sub>2</sub>
4OXY	Single Channel O <sub>2</sub> , Traditional Architecture for 120V Probes*
<b>Mounting</b>	
00	No Hardware
01	Panel Mount Kit with Gasket
02	2" Pipe / Wall Mount Kit
<b>Cable</b>	
00	No Cable
10	20' (6m) Cable, use with Traditional Architecture Probe only
11	40' (12m) Cable use with Traditional Architecture Probe only
12	60' (18m) Cable use with Traditional Architecture Probe only
13	80' (24m) Cable use with Traditional Architecture Probe only
14	100' (30m) Cable use with Traditional Architecture Probe only
15	150' (45m) Cable use with Traditional Architecture Probe only
16	200' (60m) Cable use with Traditional Architecture Probe only
<b>Stoichiometer Function for O<sub>2</sub></b>	
00	No
01	Single Channel
02	Dual Channel
<b>Programmable Reference Function for O<sub>2</sub></b>	
00	None
01	Single Channel
02	Dual Channel
<b>Extended Temperature Function for O<sub>2</sub></b>	
00	None
01	Single Channel
02	Dual Channel
<b>Plugged Diffuser Diagnostics</b>	
00	None
01	Single Channel
02	Dual Channel

\*Note: The 6888 Xi does not support World Class 44v probes.  
The X-STREAM Xi will support World Class 44v probes.

# Specifications

## Transmitter/DR Probe

### Measurement Specifications

#### Net O<sub>2</sub> Range

Variable 0-10% to 0-50%  
(Xi electronics off 0-50% O<sub>2</sub> range)

#### Accuracy in Oxidizing Conditions

±0.75% of reading or 0.05% O<sub>2</sub> whichever is greater

#### Lowest Detectable Limit

0.02% O<sub>2</sub>

#### Process Temperature Effect

Less than 0.05% O<sub>2</sub> from 100° to 700°C (212° to 1292°F)

#### System Speed of Response to Calibration Gas

Initial response in less than 3 seconds T<sub>∞</sub> in less than 8 seconds. Response to process gas changes will vary depending on process gas velocity and particulate loading of the diffuser

#### Calibration Validity

Presentation of calibration gases matches the bottle value to within ±0.02% O<sub>2</sub>

#### Accuracy in Reducing Conditions (requires stoichiometer feature)

±10% of reading or 0.1% O<sub>2</sub> whichever is greater

#### System Response in Reducing Conditions (requires stoichiometer feature)

Going from oxidizing to reducing -T90 in 120 seconds  
Going from reducing to oxidizing -T90 in 30 seconds

## Environmental Specifications

### Transmitter Probe

#### Transmitter Probe

Process-wetted materials are 316L or 304 Stainless

#### Process Temperature Limits

0° to 705°C (32° to 1300°F)

550° to 825°C (1022° to 1517°F)\* with Xi “heaterless operation” feature\*

\*Reduced cell life can be expected if operated continuously at temperatures above 705°C (1300°F)

optional bypass and jacket accessories permit operation to 1050°C (1922°F)

### Probe electronics

#### Probe electronics ambient temperature limits

-40° to 70°C (-40° to 158°F)

#### Temperature limit as measured inside probe electronics

-40° to 85°C (-40° to 185°F)

#### DR probe, no electronics inside, ambient temperature limits

-40° to 90°C (-40° to 194°F)

# Specifications

## Optional Xi electronics

NEMA 4X, Polycarbonate Material

### General Purpose Certifications



### Xi Ambient temperature limits

-20°C to 50°C (-4°F to 122°F)

### Xi Temperature Limits as Measured Inside the Electronics Housing

-20°C to 70°C (-4°F to 158°F)

## Installation Specifications - Probe

### Probe Mounting Flange

Vertical or horizontal—2" 150# (4.75" (121mm) bolt circle)

Note: Flanges are flat-faced and for mounting only. Flanges are not pressure-rated. A 2.5" diameter hole in the process is required.

Spool piece P/N 3D39761G02 is available to offset probe electronics housing from hot ductwork.

Many adapter flanges are available to mate to existing flanges.

### Probe Lengths and Approximate Shipping Weights

18 in (457 mm) package	16 pounds (7.3 Kg)
3 foot (0.91 m) package	21 pounds (9.5 Kg)
6 foot (1.83 m) package	27 pounds (12.2 Kg)
9 foot (2.74 m) package	33 pounds (15.0 kg)
12 foot (3.66 m) package	39 pounds (17.7 kg)

### Reference Air (optional)

2 scfh (1 l/min), clean, dry, instrument-quality air (20.95% O<sub>2</sub>) regulated to 5 psi (34 kPa)

### Calibration

Semi-automatic or automatic

### Cal Gases

0.4% O<sub>2</sub> and 8% O<sub>2</sub>, balance N<sub>2</sub> recommended. Instrument air may be used as a high cal gas but is not recommended.

100% nitrogen cannot be used as the low cal gas.

### Calibration Gas Flow

5 scfh (2.5l/min)

### Heater Electrical Power

120/240V ±10%, 50/60 Hz, 1/2 in.—14NPT conduit ports

### Traditional Architecture Cable

200 foot (61m) maximum length

### Power Consumption of Probe Heater

776 VA maximum during warm-up

# Specifications

## Installation Specifications Xi with Transmitter Probe

### Electrical Power of Optional Xi Electronics

120/240V ±10%, 50/60 Hz,

### Power Consumption of Xi

10 watts maximum

### Xi Alarms Relays

2 provided - 2 amps, 30 VDC

### Xi Optional Loss of Flame Contact

Removes heater power

### Electrical Noise

Meets EN 61326, Class A

### Traditional Architecture Cable

200 ft (61m) maximum length

### Transmitter Electrical 4-20 mA Power

12 - 42VDC, (looped-powered from the control room or from the Xi box)

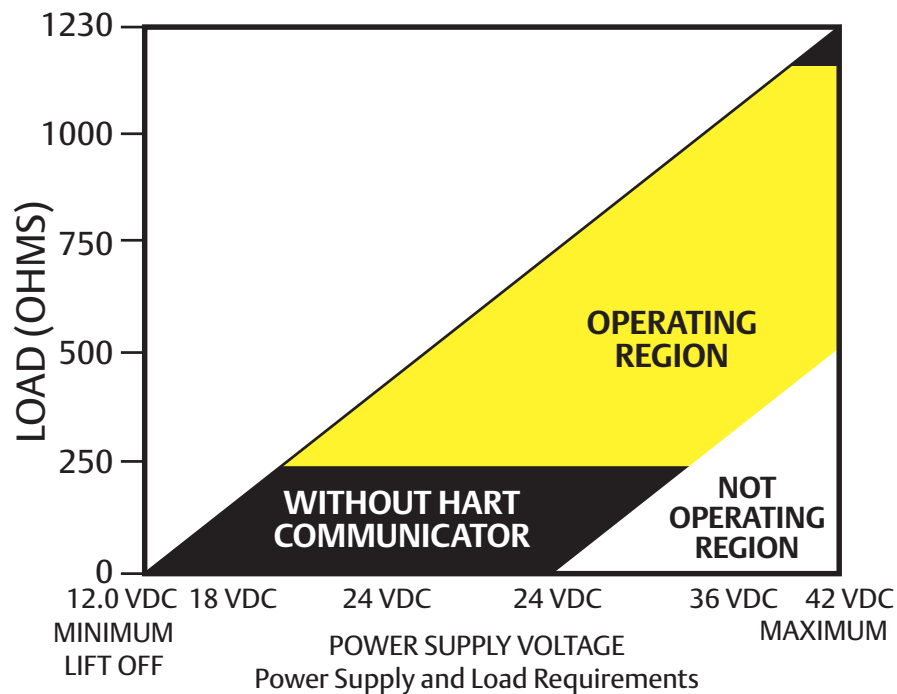

# Specifications

## Installation Specifications for Traditional Architecture Xi for use with DR or other Probe

### Electrical Power for Xi

120/240V  $\pm$ 10%, 50/60 Hz

### Power Consumption of Xi

12 VA maximum or 1020 VA maximum with Traditional Architecture, 120V Probes.  
450 VA maximum with Traditional Architecture 44V Probes

### Alarm Relay Outputs

Two provided - 2 Amperes, 30 VDC, Form-C

### Optional Loss of Flame Input

Internally powered input to remove heater power actuated via dry contact output from prove of flame device.



Emerson Process Management has satisfied all obligations coming from the European legislation to harmonize the product requirements in Europe.



C US

# Installation

## **⚠ WARNING**

Before installing this equipment read the "Safety instructions for the wiring and installation of this apparatus" at the front of this Instruction Manual. Failure to follow safety instructions could result in serious injury or death.

## **⚠ WARNING**

Install all protective equipment covers and safety ground leads after installation. Failure to install covers and ground leads could result in serious injury or death.

## **⚠ WARNING**

The 6888A O<sub>2</sub> Transmitter can be installed in general purpose areas only. Do not install the 6888A Transmitter in hazardous areas or in the vicinity of flammable liquids.

## Mechanical Installation

Note that most combustion processes run only slightly negative or positive in pressure, so the probe flange is for mechanical mounting, only. The probe is not rated for high pressures. If this is a new installation, a "weld plate" for welding to the flue gas duct can be supplied.

### 6888A Probe Installation

1. Ensure all components are available to install the 6888A O<sub>2</sub> probe. Refer to Figure 1.
2. If using the optional ceramic diffusion element, the vee deflector must be correctly oriented. Before inserting the 6888A probe, check the direction of gas flow in the duct. Orient the vee deflector so the apex points upstream toward the flow. See Figure 2.
3. If using the standard square weld plate or an optional flange mounting plate (Figure 3) weld or bolt the plate onto the duct. The through hole diameter in the stack or duct wall and refractory material must be at least 2-1/2 in. (63.5 mm).
4. Insert probe through the opening in the mounting flange and bolt the unit to the flange.

**CAUTION**

Do not allow the temperature of the 6888A electronics to exceed 85°C (185°F) or damage to the unit may result.

Figure 2. Orienting the Optional Vee Deflector

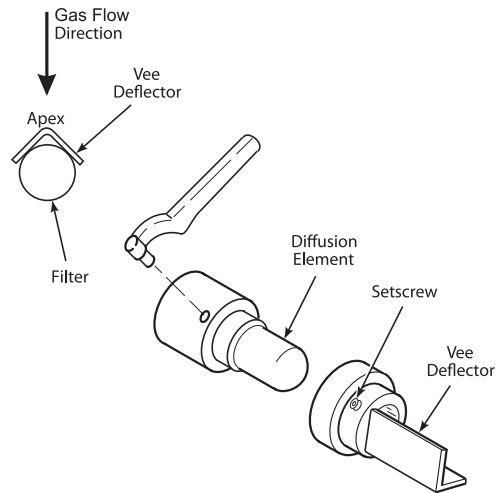

**CAUTION**

CAUTION If the ducts will be washed down during outage MAKE SURE to power down the probes and remove them from the wash area.

# Installation

## 6888A Probe Installation

Figure 3

NOTE: ALL DIMENSIONS ARE IN INCHES  
WITH MILLIMETERS IN PARENTHESES

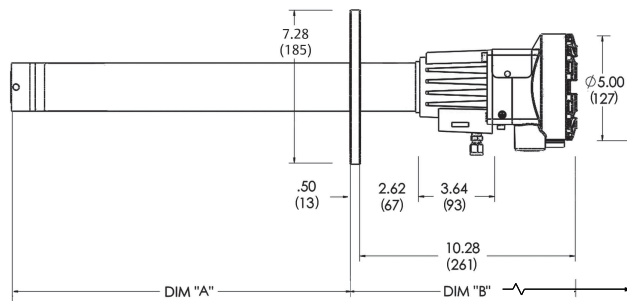

6888A Probe with Standard Terminations/Electronics Housing

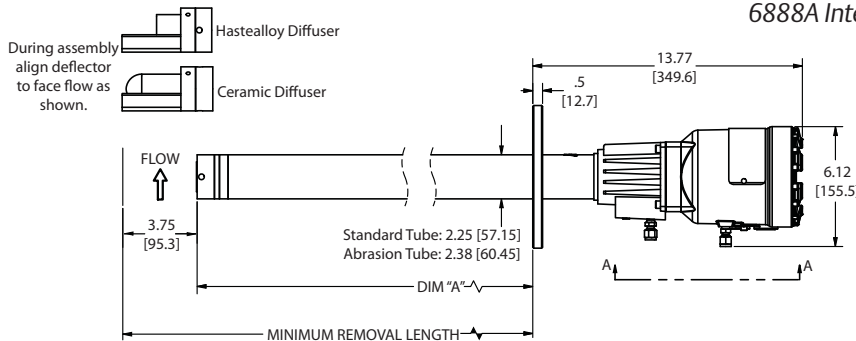

6888A Integral Autocal Housing

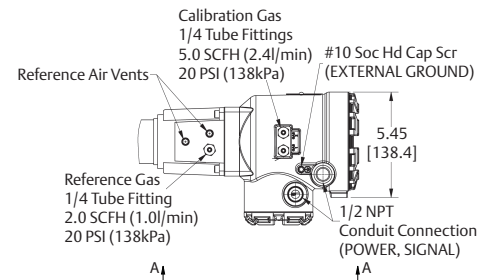

Table 2. Removal/ Installation*			
Probe Length	DIM "A" Insertion Depth	DIM "B" Removal Envelope Standard Housing	DIM "B" Removal Envelope Accessory Housing
18 IN. (457 mm) Probe	16.10 (409)	15.77 (401)	19.26 (490)
3 FT. (0.91 m) Probe	32.52 (826)	46.6 (1182)	50.1 (1271)
6 FT. (1.83 m) Probe	68.52 (1740)	82.6 (2097)	86.1 (2186)
9 FT. (2.74 m) Probe	104.52 (2655)	118.6 (3011)	122.1 (3100)
12 FT. (3.66 m) Probe	140.52 (3569)	154.6 (3926)	158.1 (4015)

\* Add 3.80 (96) to DIM "A" and DIM "B" for probe with ceramic or Hastelloy™ diffuser.

# Installation

## 6888A Probe Installation

### Figure 3

NOTE: ALL DIMENSIONS ARE IN INCHES  
WITH MILLIMETERS IN PARENTHESES

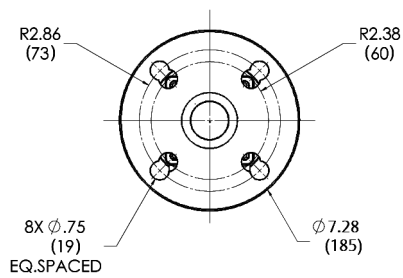

	ANSI	DIN
Flange Dia	7.28 (185)	
Hold Dia	.75 (20)	
(4) Holes Eq Sp on BC	4.75 (121)	5.71 (145)

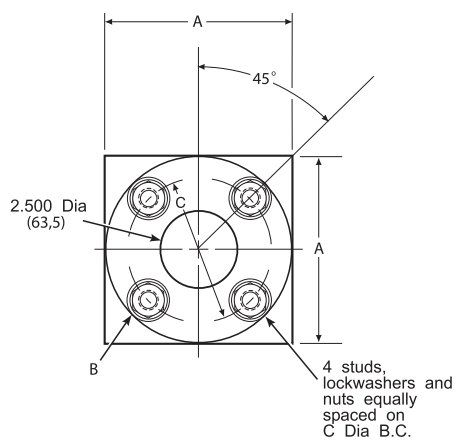

	ANSI	DIN
"A"	6.00(153)	7.5(191)
"B" Thread	.625(11)	(M-16x2)
"C" Dia	4.75(121)	5.708(145)

# Installation

## Drip Loop and Insulation Removal

Figure 4

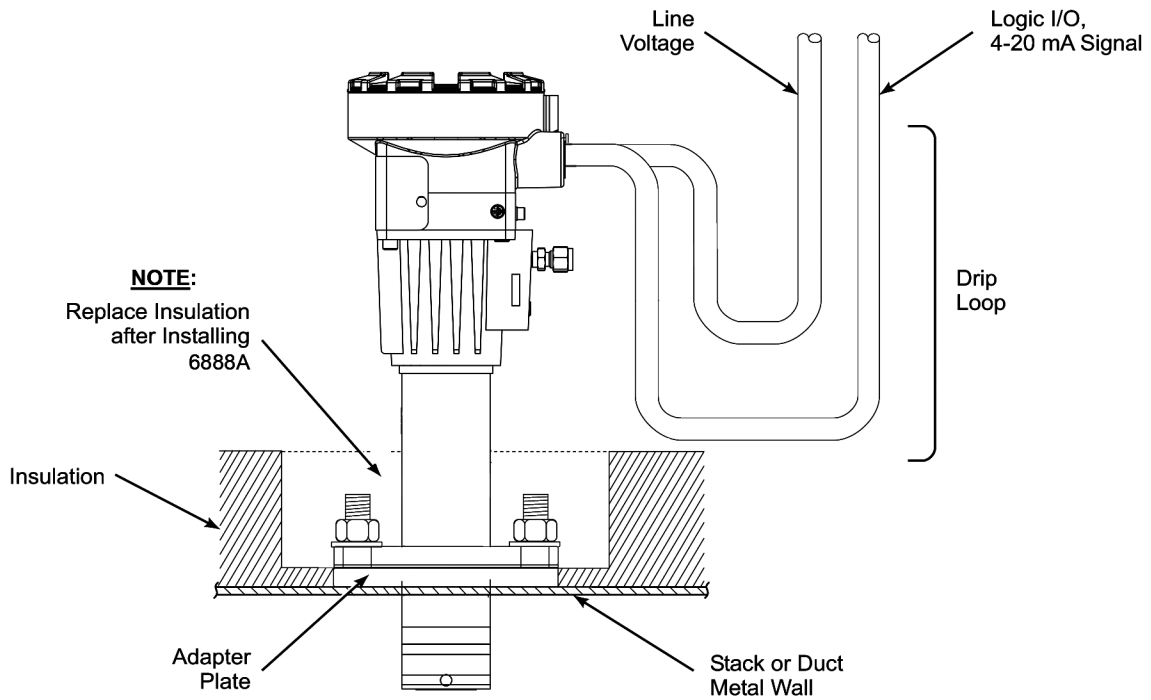

Note: Standard housing probe shown. Accessory housing is similar. Probe installation may be vertical or horizontal.

# Installation

## 6888Xi Advanced Electronics

The 6888Xi Advanced Electronics is available in a panel mounting, or wall/pipe mounting configuration. Refer to Figure 5 or Figure 6 for the panel, wall, or pipe mounting details.

1. Ensure all components are available to install the 6888Xi.
2. Select a mounting location near or removed from the O<sub>2</sub> Probe. Consider the temperature limitations of the 6888Xi (see "Specifications") when selecting the mounting location.
3. Mount the 6888Xi at a height convenient for viewing and operating the interface. Approximately 5 ft (1,5 m) is recommended.
4. The keypad window on the 6888Xi may have interior and exterior protective membranes. Remove the protective membranes prior to use of the 6888Xi enclosure. Failure to remove the protective membranes may cause the display to appear distorted. The membrane may be difficult or impossible to remove after extended use at elevated temperatures.

# Installation

## Wall/Surface and Pipe Mount

### Figure 5

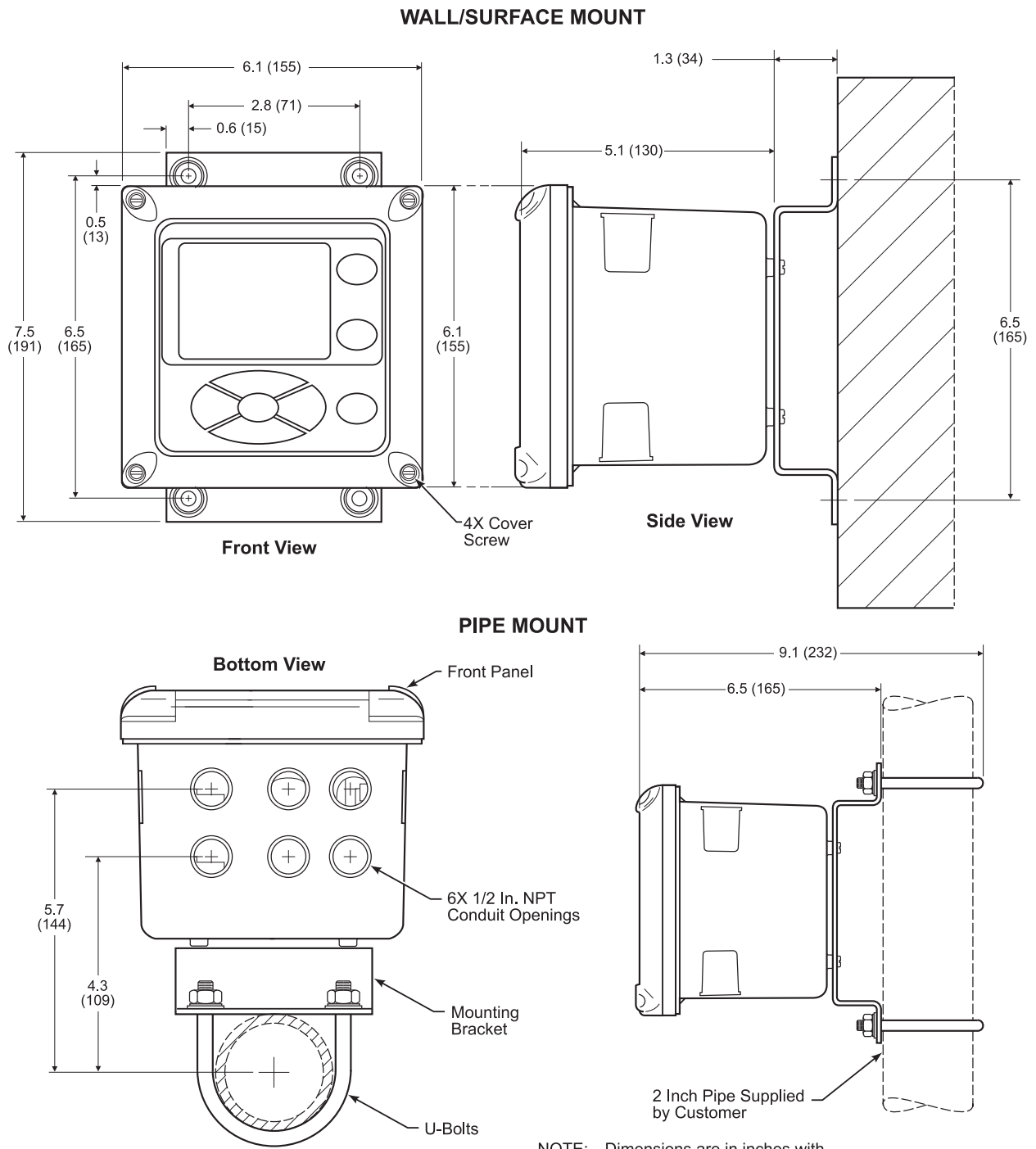

NOTE: Dimensions are in inches with millimeters in parentheses.

# Installation

## Panel Mount

Figure 6

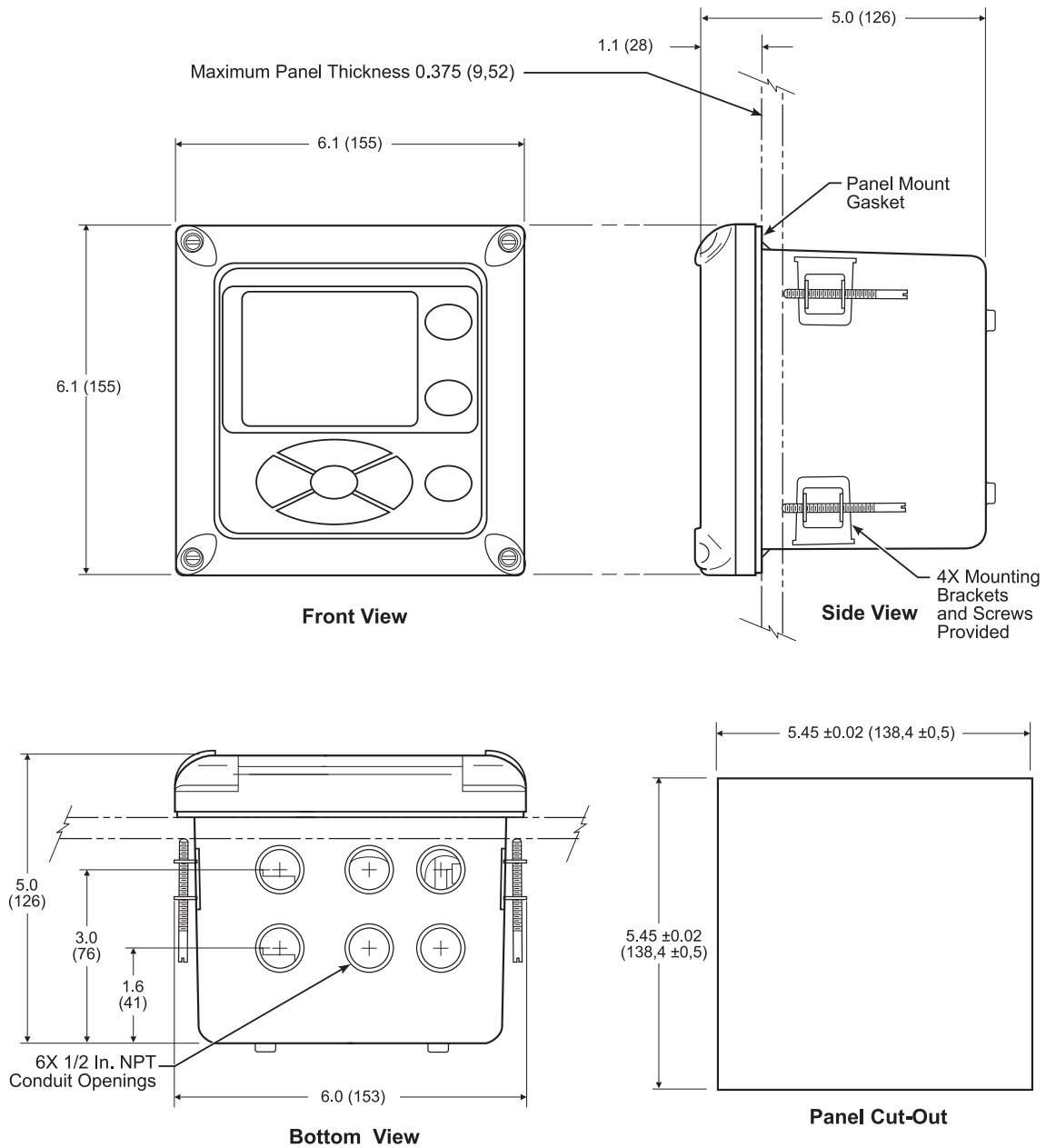

- NOTES: 1. Dimensions are in inches with millimeters in parentheses.  
2. The front panel is hinged at the bottom. The panel swings down for easy access to the wiring locations.

# Installation

## Electrical

All wiring must conform to local and national codes. Multiple wiring diagrams are shown in this section. Always refer to the diagrams that apply to your transmitter configuration and disregard all other wiring diagrams.

### **⚠ WARNING**

**Disconnect and lock out power before connecting the power supply.**

**Install all protective covers and safety ground leads after installation. Failure to install covers and ground leads could result in serious injury or death.**

**To meet the Safety Requirements of IEC 61010-1 (EC requirement), and ensure safe operation of this equipment, connection to the main electrical power supply must be made through a circuit breaker (min 10A) which will disconnect all current-carrying conductors during a fault situation. This circuit breaker should also include a mechanically operated isolating switch. If not, then another external means of disconnecting the supply from the equipment should be located close by. Circuit breakers or switches must comply with a recognized standard such as IEC 60947.**

### **⚠ WARNING**

**Before installing this equipment read the "Safety instructions for the wiring and installation of this apparatus" at the front of this Instruction Manual. Failure to follow safety instructions could result in serious injury or death.**

### **⚠ CAUTION**

**If external loop power is used, the power supply must be a safety extra low voltage (SELV) type.**

Note:

To maintain proper earth grounding ensure a positive connection exists between the transmitter housing and earth. The connecting ground wire must be 14 AWG minimum.

Note:

Line voltage, signal, and relay wiring must be rated for at least 105°C (221°F).

Note:

If metal conduit is used with the 6888Xi the conduit should be reliably bonded to protective earth. The grounding plate inside the 6888Xi is not bonded to PE and does not provide adequate grounding.

## Wiring for 6888 transmitter probe only (no 6888 Xi electronics)

The 6888 transmitter probe has the electronics in the blue housing that controls the heater temperature, and also amplifies the raw O<sub>2</sub> millivolt signal to a linear 4-20 mA. The 4-20 mA signal lines can be run directly to the control room, and also power the transmitter electronics. There is no O<sub>2</sub> display or keypad on the probe, so set-up must be conducted through HART communications via a 475 handheld communicator, or via Asset Management Solutions (AMS).

1. Remove the cover from probe.
2. Refer to Figure 7. Connect the line (L1 wire) to the L1 terminal, the neutral (L2 wire) to the L2/N terminal, and the ground wire to the ground lug. The 6888A accepts 120/240 VAC ±10% line voltage and 50/60 Hz. No setup is required.

# Installation

Figure 7

### Model 6888A Transmitter Probe (No Xi Electronics)

#### Model 6888A Product Matrix

Compare the configuration matrix below to the model number on the probe tag to confirm the features present in this specific probe.

Housing & Electronics	
1HT	Standard Housing, Transmitter Electronics, HART Communications
2HT	Integral Autocal, Transmitter Electronics, HART Communications
4FF	Integral Autocal, Transmitter Electronics, Fieldbus Communications
5DR	Standard Housing, Direct Replacement, No Electronics
6DRY	Standard Housing, Direct Replacement, YEW Electronics

6888A Standard Probe Housing

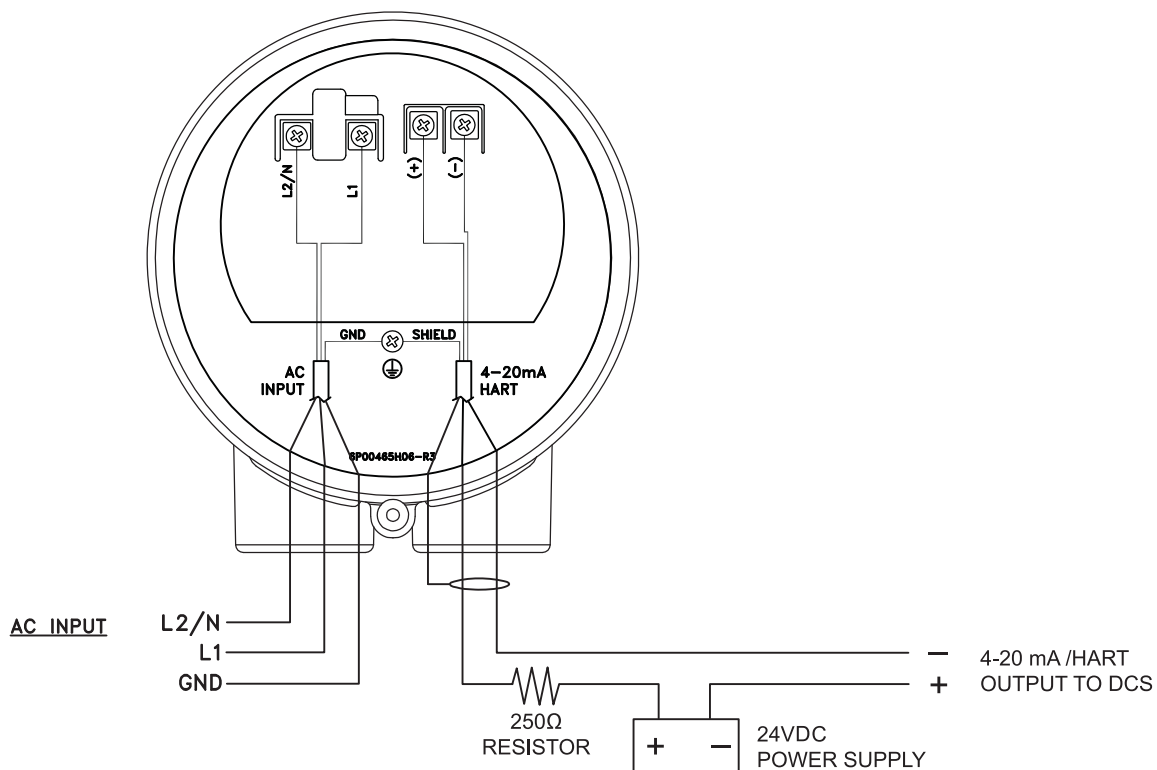

3. Connect the 4-20 mA signal wires at the transmitter. Use a shielded twisted wire pair. Do not allow bare shield wires to contact the circuit boards. Insulate the shield wires prior to termination. The transmitter electronics are loop-powered, ie, the 4-20mA signal wires supply 24 VDC from the DCS, or an external power supply.
4. Terminate the shield only at the transmitter electronics housing unless using a 6888Xi. When using the 6888Xi Advanced Electronics, terminate the shield at both ends.

#### NOTE

The 4-20 mA signal represents the O<sub>2</sub> value and also powers the probe-mounted electronics. Superimposed on the 4-20 mA signal is HART information accessible through a 475 Field Communicator or AMS software.

5. Reinstall cover on transmitter.
6. Follow the remaining electrical installation instructions only if the 6888Xi is included with your system configuration.

# Installation

## Standard Housing Transmitter Probe plus 6888Xi Electronics

The 6888Xi electronics serve as an operator interface unit, with a back-lit display and keypad. It is capable of two channels, serving two 6888 probes.

1. Remove cover screws from the front cover of the 6888Xi. Swing down the front cover of the interface box.
2. Pull out the I/O board on the right-hand side of the card rack inside the 6888Xi. If your system is configured to operate two transmitter probes there are two I/O interface boards.
3. See Figure 8. Connect the 4-20 mA signal wires at J4 of the I/O board. Attach the supplied ferrite clamp over the 4-20 mA OUT wires that extend past the shield.

### NOTE

Installation of the ferrite clamp over the 4-20 mA OUT wires is required for compliance with the European EMC Directive.

4. Terminate the shield of the 4-20 mA signal wires at the designated ground terminal of the 6888Xi. Do not allow bare shield wires to contact the circuit boards. Insulate the shield wires prior to termination.
5. Connect the signal wires from the SPS or IMPS (if used) to the applicable terminals of J3. Refer to the SPS or IMPS instruction manual for wiring details.
6. Reinstall the I/O board in the card rack of the 6888Xi.
7. If your system is configured for two channel operation, repeat steps 2 through 7 to connect the other probe's signal wires.
8. Remove the probe's connector from the power supply board located on the left-hand side of the card rack inside the 6888Xi.
9. Connect the line, or L1 wire to the L1 terminal and the neutral, or L2 wire, to the N terminal.
10. Reinstall the power supply connector in the power supply board.

# Wiring Diagrams

## Single/Dual Channel Wiring Diagram

### Figure 8

#### Model 6888A Transmitter Probe With Single/Dual Channel Xi Electronics

##### Model 6888A Product Matrix

Compare the configuration matrix below to the model number on the probe tag to confirm the features present in this specific probe.

Housing & Electronics	
1HT	Standard Housing, Transmitter Electronics, HART Communications
2HT	Integral Autocal, Transmitter Electronics, HART Communications
4FF	Integral Autocal, Transmitter Electronics, Fieldbus Communications
5DR	Standard Housing, Direct Replacement, No Electronics
6DRY	Standard Housing, Direct Replacement, YEW Electronics

##### Model 6888Xi Product Matrix

Compare the configuration matrix below to the model number on the probe tag to confirm the features present in this specific probe.

Remote Type	
1OXY	Single Channel O <sub>2</sub>
2OXY	Single Channel O <sub>2</sub> with Flame Safety Interlock for Heater
3OXY	Dual Channel O <sub>2</sub>
4OXY	Single Channel O <sub>2</sub> , Traditional Architecture for 120V Probes*

#### NOTES:

- EXCEPT FOR JP5, JP7 AND JP8 ON IO BOARD, JUMPER AND SWITCH SETTING ARE FACTORY SET AND ARE SHOWN FOR REFERENCE ONLY.
- IO BOARD 4-20mA/HART LOOP POWER SETTINGS  
 JP5: PINS 1-2 INTERNAL POWER 6888XI TO 6888 TRANSMITTER  
 PINS 2-3 EXTERNAL POWER 6888XI TO 6888 TRANSMITTER  
 (REQUIRES 250Ω RESISTOR ACROSS J4, PR+ TO PR-)  
 JP7/JP8: PINS 1-2 INTERNAL POWER 6888XI TO DCS  
 PINS 2-3 EXTERNAL POWER 6888XI TO DCS

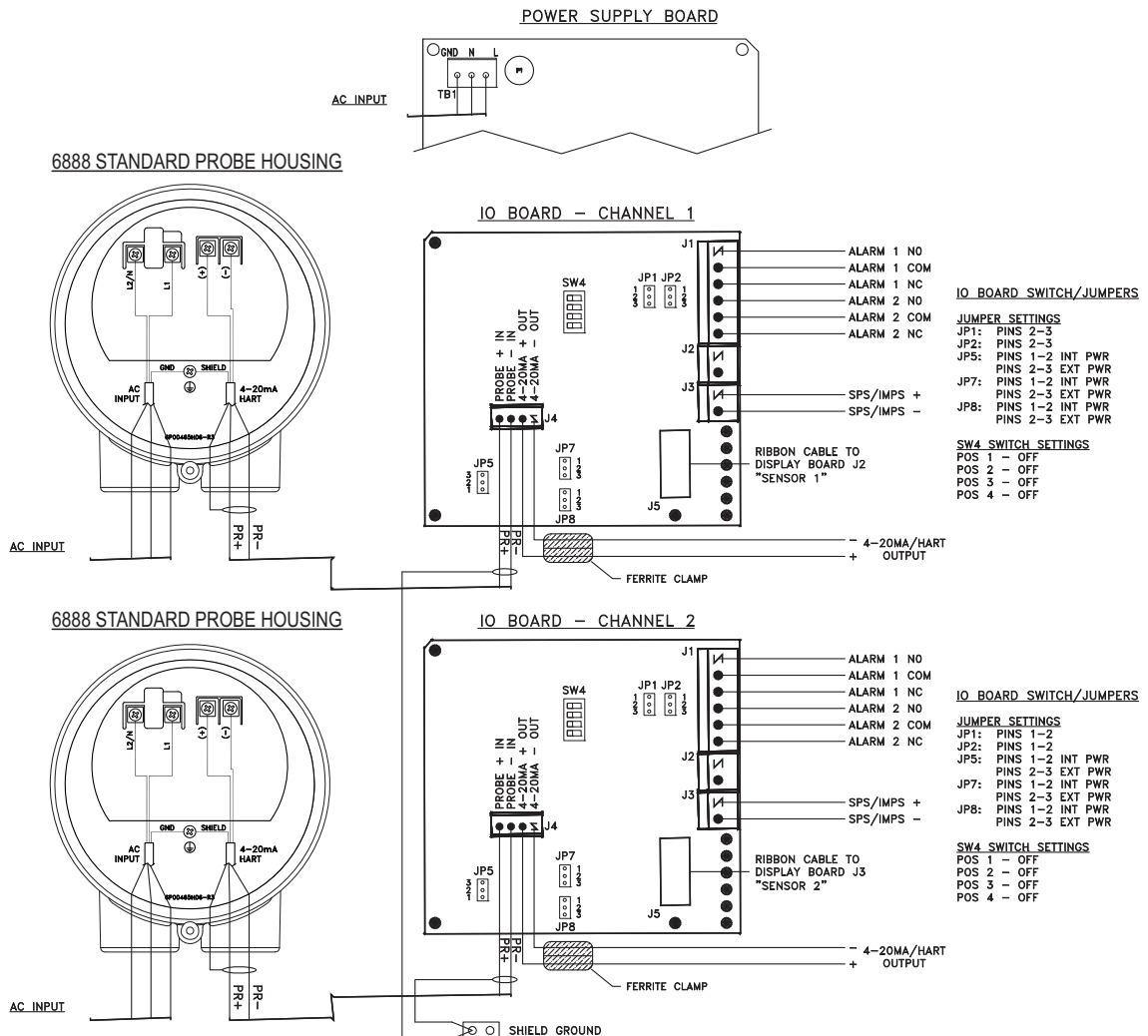

# Wiring Diagrams

## Single/Dual Channel Wiring Diagram (continued) Figure 8

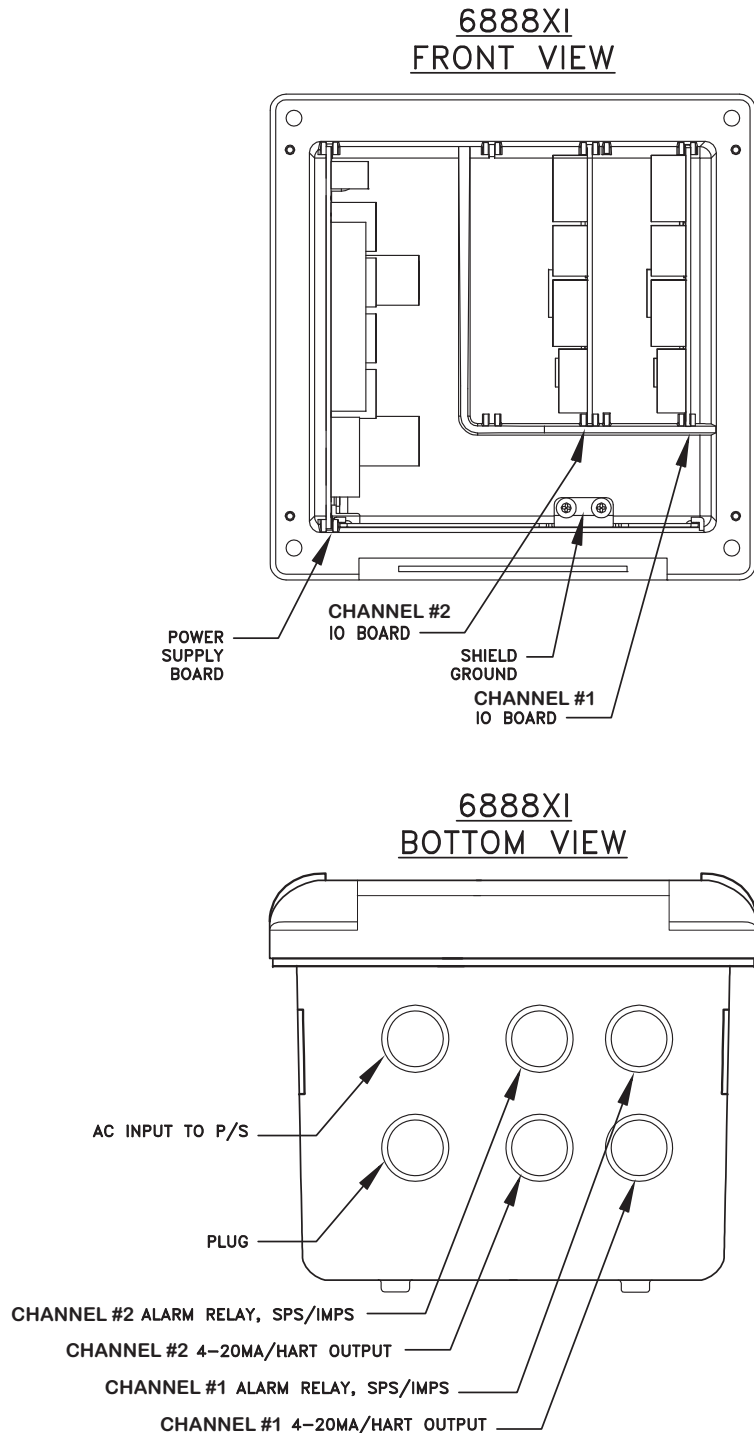

# Installation

## Transmitter probe with single-channel Xi and Flame Safety Interlock

A flame safety interlock by Emerson Process Management is available for heater power disconnect whenever there is a loss of the process flame or a heater runaway condition (heater over-temperature) in the O<sub>2</sub> Probe. This input is internally powered by the 6888Xi and is actuated via a dry contact output from the user's flame scanner. A closed contact indicates a flame is present. An open contact indicates a loss of flame.

1. Refer to figure 9. Connect the signal wires from the burner management system flame status output to the flame status input terminals of J2. The flame status sensing device is supplied by the customer. Refer to the applicable OEM documents for signal wiring details.
2. Remove the J1 and J2 connectors from the AC relay board.
3. Connect the AC line input to the J1 connector.
4. Connect the AC power to the 6888A probe to the J2 connector.
5. Reinstall connector J1 and J2 to the AC relay board.

**This page intentionally left blank.**

# Wiring Diagrams

## Single Channel with Flame Safety Wiring Diagram

Figure 9

### Model 6888A Transmitter Probe With Single Channel Xi Electronics And Flame Safety Interlock

#### Model 6888A Product Matrix

Compare the configuration matrix below to the model number on the probe tag to confirm the features present in this specific probe.

Housing & Electronics	
1HT	Standard Housing, Transmitter Electronics, HART Communications
2HT	Integral Autocal, Transmitter Electronics, HART Communications
4FF	Integral Autocal, Transmitter Electronics, Fieldbus Communications
SDR	Standard Housing, Direct Replacement, No Electronics
6DRY	Standard Housing, Direct Replacement, YEW Electronics

#### Model 6888Xi Product Matrix

Compare the configuration matrix below to the model number on the probe tag to confirm the features present in this specific probe.

Remote Type	
10XY	Single Channel O <sub>2</sub>
20XY	Single Channel O <sub>2</sub> with Flame Safety Interlock for Heater
30XY	Dual Channel O <sub>2</sub>
40XY	Single Channel O <sub>2</sub> , Traditional Architecture for 120V Probes*

**NOTES:**

- SEE INSTRUCTION MANUAL 51-6888XI FOR ADDITIONAL INSTALLATION AND OPERATING INSTRUCTIONS.
- ALL WIRING MARKED WITH AN ASTERISK (\*) IS FACTORY WIRING INSIDE THE 6888XI.
- EXCEPT FOR JP5, JP7 AND JP8 ON IO BOARD, JUMPER AND SWITCH SETTING ARE FACTORY SET AND ARE SHOWN FOR REFERENCE ONLY.
- IO BOARD 4-20MA/HART LOOP POWER SETTINGS  
 JP5: PINS 1-2 INTERNAL POWER 6888XI TO 6888 TRANSMITTER  
 PINS 2-3 EXTERNAL POWER 6888XI TO 6888 TRANSMITTER (REQUIRES 250Ω RESISTOR ACROSS J4, PR+ TO PR-)  
 JP7/JP8: PINS 1-2 INTERNAL POWER 6888XI TO DCS  
 PINS 2-3 EXTERNAL POWER 6888XI TO DCS

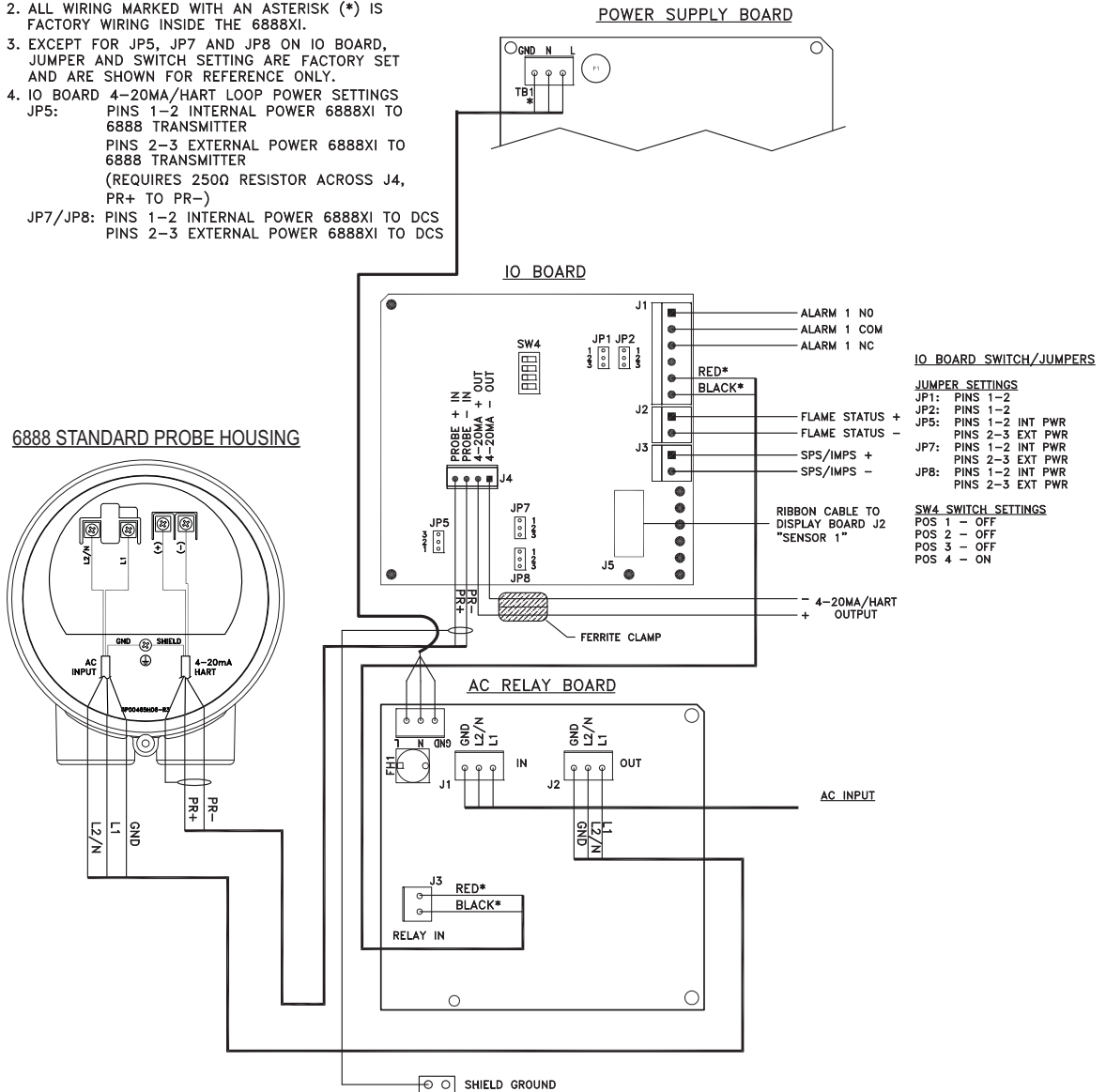

# Wiring Diagrams

## Single Channel with Flame Safety Wiring Diagram (continued)

Figure 9

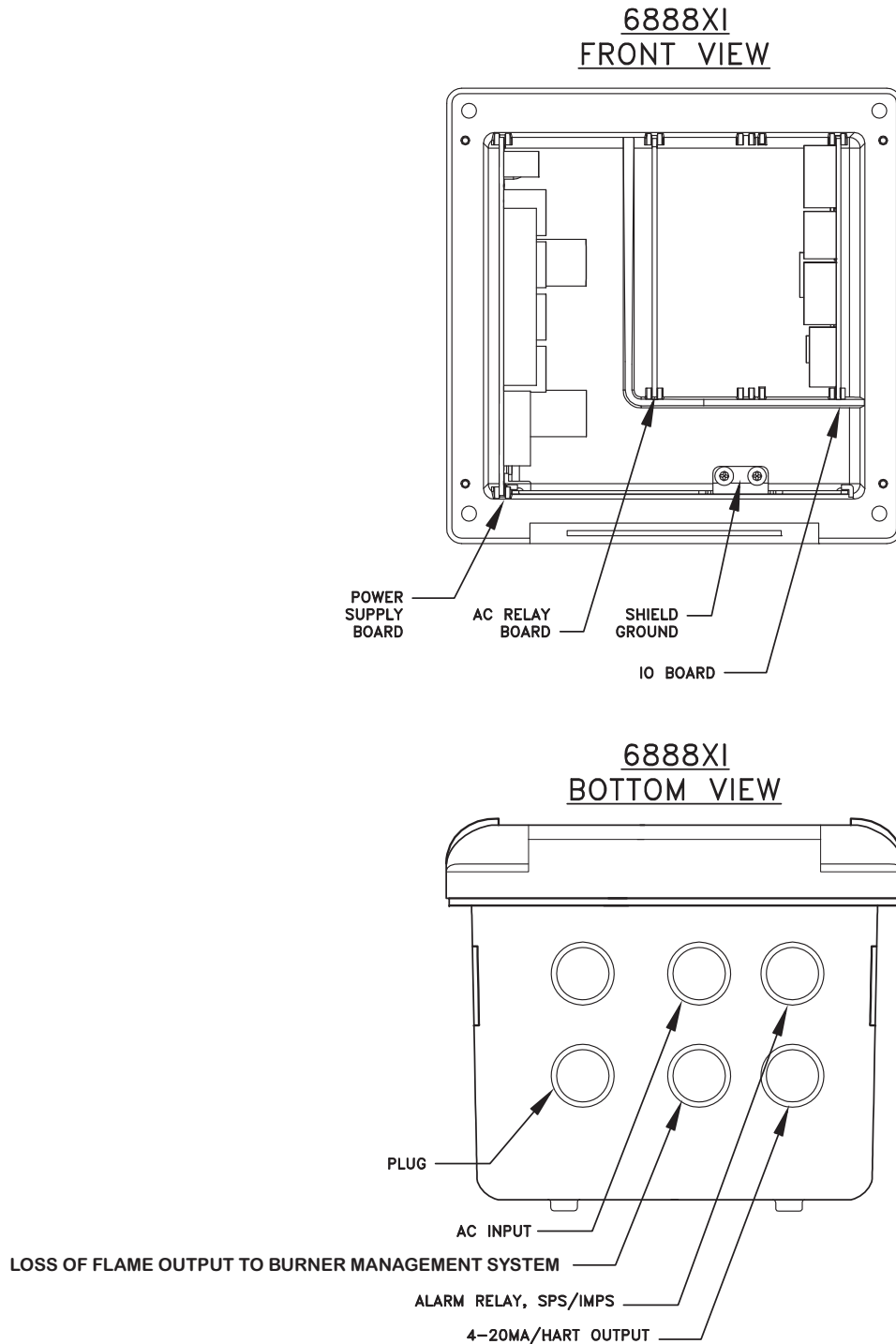

# Installation

## Transmitter Probe with Integral Autocal and HART communications

This probe contains gas-switching solenoids so that the 6888Xi electronics can control the introduction of calibration gases. Calibrations can be initiated via a calibration recommended diagnostic, time since last calibration, manually via external dry contact, HART communications, or from the 6888Xi local operator interface keypad. The integral autocal feature can only be implemented when the probe is used with a 6888Xi.

1. Remove the two covers from the transmitter.
2. Refer to Figure 10. Connect the line (L1 wire) to the L1 terminal, the neutral (L2 wire) to the L2/N terminal, and the ground wire to the ground lug. The 6888A accepts 120/240 VAC  $\pm$  10% line voltage and 50/60 Hz. No setup is required.
3. Connect the 4-20mA signal wires from the 6888Xi to the connections in the side chamber of the transmitter. DO NOT connect the signal wires to the terminals in the main chamber where the AC input wires are connected. Use a shielded twisted wire pair. Do not allow bare shield wires to contact the circuit boards. Insulate the shield wires prior to termination. The 24 VDC loop power is sourced from the 6888Xi.
4. Terminate the shield at both the probe and the 6888Xi Advanced Electronics.

### NOTE

The 4-20 mA signal represents the O<sub>2</sub> value and also powers the probe-mounted electronics. Superimposed on the 4-20 mA signal is HART information accessible through a Field Communicator or AMS software.

5. Reinstall both covers on transmitter.
6. Follow the remaining electrical installation instructions for the 6888Xi included with your system configuration.

**This page intentionally left blank.**

# Wiring Diagrams

## Integral Autocal and HART Communications

### Figure 10

#### Model 6888A Transmitter Probe With Integral Autocal With Single/Dual Channel Xi Electronics (HART)

##### Model 6888A Product Matrix

Compare the configuration matrix below to the model number on the probe tag to confirm the features present in this specific probe.

Housing & Electronics	
1HT	Standard Housing, Transmitter Electronics, HART Communications
2HT	Integral Autocal, Transmitter Electronics, HART Communications
4FR	Integral Autocal, Transmitter Electronics, Fieldbus Communications
5DR	Standard Housing, Direct Replacement, No Electronics
6DRY	Standard Housing, Direct Replacement, YEW Electronics

##### Model 6888Xi Product Matrix

Compare the configuration matrix below to the model number on the probe tag to confirm the features present in this specific probe.

Remote Type	
10XY	Single Channel O <sub>2</sub>
20XY	Single Channel O <sub>2</sub> with Flame Safety Interlock for Heater
30XY	Dual Channel O <sub>2</sub>
40XY	Single Channel O <sub>2</sub> , Traditional Architecture for 120V Probes*

#### NOTES:

- EXCEPT FOR JP5, JP7 AND JP8 ON IO BOARD, JUMPER AND SWITCH SETTING ARE FACTORY SET AND ARE SHOWN FOR REFERENCE ONLY.
- IO BOARD 4-20MA/HART LOOP POWER SETTINGS  
 JP5: PINS 1-2 INTERNAL POWER 6888XI TO 6888 TRANSMITTER  
 PINS 2-3 EXTERNAL POWER 6888XI TO 6888 TRANSMITTER  
 (REQUIRES 250Ω RESISTOR ACROSS J4, PR+ TO PR-)  
 JP7/JP8: PINS 1-2 INTERNAL POWER 6888XI TO DCS  
 PINS 2-3 EXTERNAL POWER 6888XI TO DCS

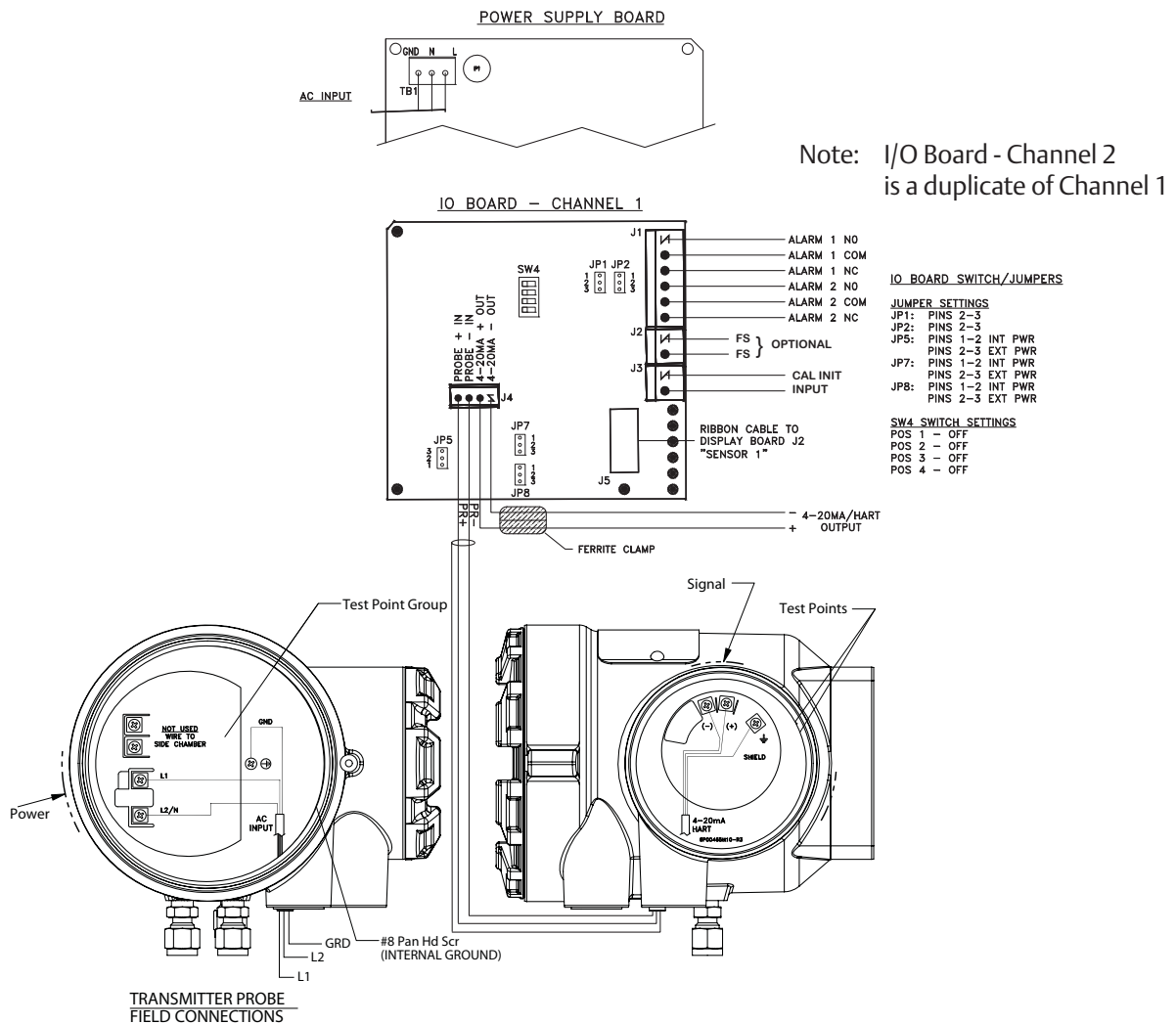

# Wiring Diagrams

## Integral Autocal and HART Communications (continued) Figure 10

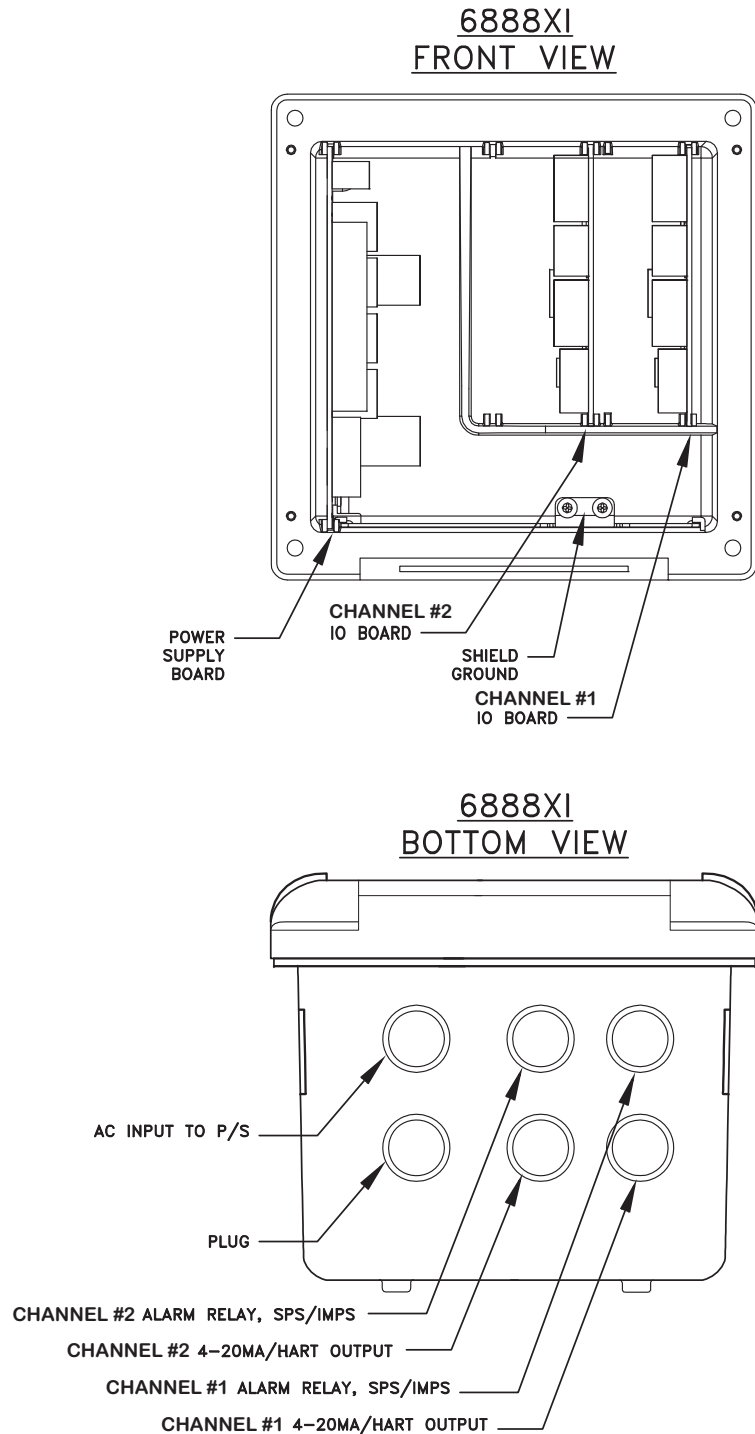

# Installation

## Transmitter Probe with Integral Autocal and FOUNDATION Fieldbus communications

This probe contains gas-switching solenoids so that the 6888Xi electronics can control the introduction of calibration gases. Calibrations can be initiated via a calibration recommended diagnostic, time since last calibration, manually via external dry contact, HART communications, or from the 6888Xi local operator interface keypad. The integral autocal feature can only be implemented when the probe is used with a 6888Xi.

1. Remove the two covers from the transmitter.
2. Refer to Figure 11. Connect the line (L1 wire) to the L1 terminal, the neutral (L2 wire) to the L2/N terminal, and the ground wire to the ground lug. The 6888A accepts 120/240 VAC  $\pm$  10% line voltage and 50/60 Hz. No setup is required.
3. Connect the FOUNDATION Fieldbus wires from the 6888 side housing to the FF segment. Note that the 6888 probe is not rated as intrinsically safe, and will render any IS or FISCO segment it is wired to as non-IS. Use a shielded twisted wire pair. Do not allow bare shield wires to contact the circuit boards.
4. Terminate the shield at both the probe and the 6888Xi Advanced Electronics.

### NOTE

The FOUNDATION Fieldbus signal represents the O<sub>2</sub> value and also powers the probe-mounted electronics.

5. Reinstall both covers on transmitter.
6. Follow the remaining electrical installation instructions for the 6888Xi included with your system configuration.

# Wiring Diagrams

## Integral Autocal and FOUNDATION Fieldbus Communications without Optional Xi

Figure 11

**Model 6888A Transmitter Probe With Integral Autocal Foundation Fieldbus(FF) and No Xi Electronics**

**Model 6888A Product Matrix**

Compare the configuration matrix below to the model number on the probe tag to confirm the features present in this specific probe.

Housing & Electronics	
1HT	Standard Housing, Transmitter Electronics, HART Communications
2HT	Integral Autocal, Transmitter Electronics, HART Communications
4FF	Integral Autocal, Transmitter Electronics, Fieldbus Communications
5DR	Standard Housing, Direct Replacement, No Electronics
6DRY	Standard Housing, Direct Replacement, YEW Electronics

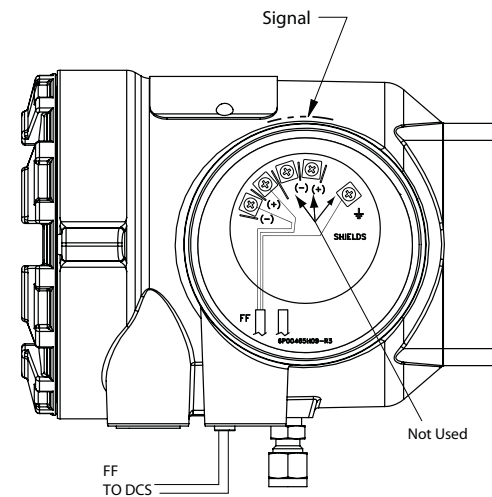
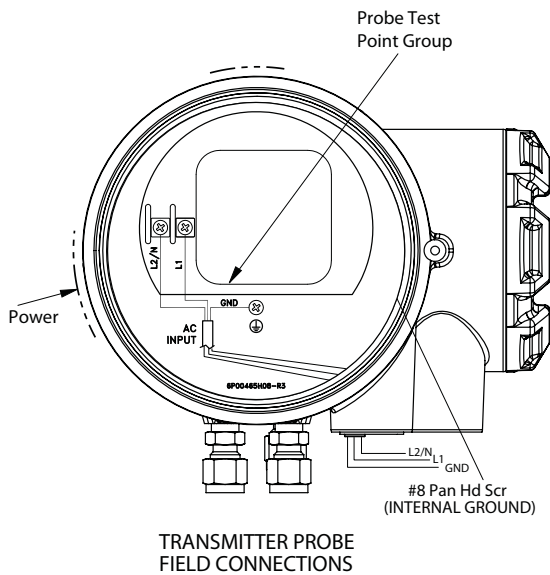

# Wiring Diagrams

## Integral Autocal and FOUNDATION Fieldbus Communications and Optional Xi

Figure 12

### Model 6888A Transmitter Probe With Integral Autocal(FF) With Single/Dual Channel Xi Electronics

#### Model 6888A Product Matrix

Compare the configuration matrix below to the model number on the probe tag to confirm the features present in this specific probe.

Housing & Electronics	
1HT	Standard Housing, Transmitter Electronics, HART Communications
2HT	Integral Autocal, Transmitter Electronics, HART Communications
4FF	Integral Autocal, Transmitter Electronics, Fieldbus Communications
5DR	Standard Housing, Direct Replacement, No Electronics
6DRY	Standard Housing, Direct Replacement, YEW Electronics

#### Model 6888Xi Product Matrix

Compare the configuration matrix below to the model number on the probe tag to confirm the features present in this specific probe.

Remote Type	
10XY	Single Channel O <sub>2</sub>
20XY	Single Channel O <sub>2</sub> , with Flame Safety Interlock for Heater
30XY	Dual Channel O <sub>2</sub>
40XY	Single Channel O <sub>2</sub> , Traditional Architecture for 120V Probes*

**NOTES:**

- EXCEPT FOR JP5, JP7 AND JP8 ON IO BOARD, JUMPER AND SWITCH SETTING ARE FACTORY SET AND ARE SHOWN FOR REFERENCE ONLY.
- IO BOARD 4-20mA/HART LOOP POWER SETTINGS  
 PINS 1-2 INTERNAL POWER 6888XI TO 6888 TRANSMITTER  
 PINS 2-3 EXTERNAL POWER 6888XI TO 6888 TRANSMITTER  
 (REQUIRES 250Ω RESISTOR ACROSS J4, PR+ TO PR-)

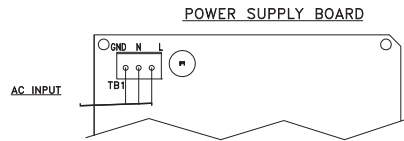

Note: I/O Board - Channel 2 is a duplicate of Channel 1

#### IO BOARD - CHANNEL 1

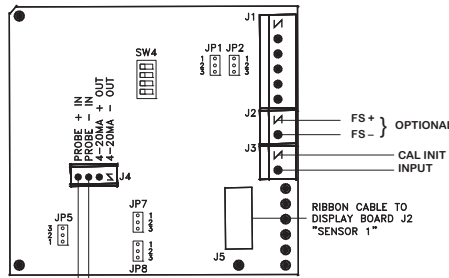

#### IO BOARD SWITCH/JUMPERS

- JUMPER SETTINGS**  
 JP1: PINS 2-3  
 JP2: PINS 2-3  
 JP5: PINS 1-2 INT PWR  
 PINS 2-3 EXT PWR  
 JP7: PINS 1-2 INT PWR  
 PINS 2-3 EXT PWR  
 JP8: PINS 1-2 INT PWR  
 PINS 2-3 EXT PWR
- SW4 SWITCH SETTINGS**  
 POS 1 - OFF  
 POS 2 - OFF  
 POS 3 - OFF  
 POS 4 - OFF

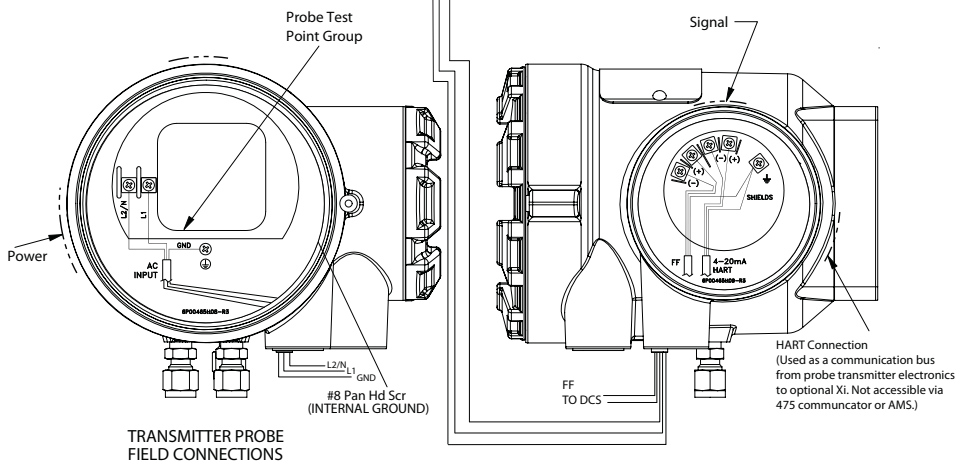

# Wiring Diagrams

## Integral Autocal and FOUNDATION Fieldbus Communications and Optional Xi (continued)

Figure 12

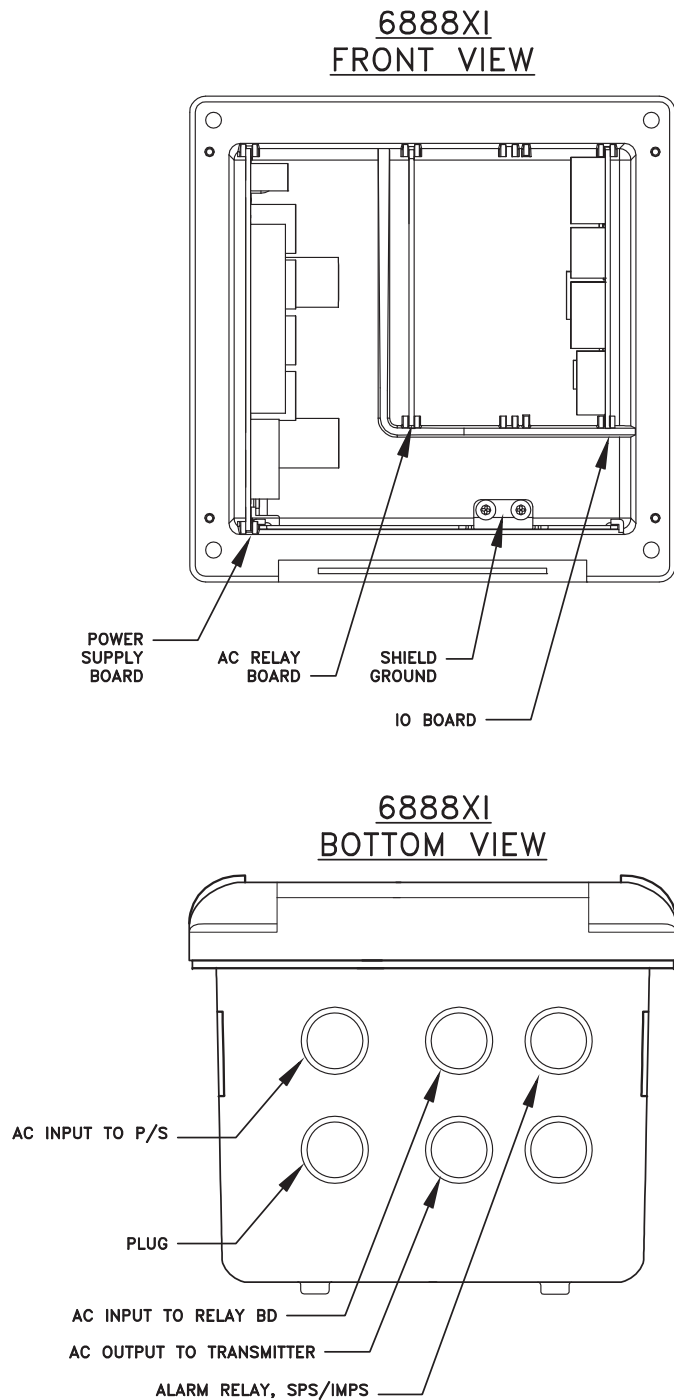

# Installation

## Traditional Architecture System with Direct Replacement Probe (no electronics inside)

Here there are no electronics inside the probe head, so the raw sensor signals for the heater thermocouple and zirconium oxide O<sub>2</sub> sensor are sent to a remote 6888Xi Electronics. The 6888Xi electronics will also directly apply power to the probe heater in order to maintain the correct sensor temperature. This arrangement calls for a 7-conductor cable to carry this power and the sensor signals. Maximum length for this cable is 200 feet.

1. Remove cover from probe.
2. Feed all DR probe wiring through the conduit port of probe.
3. Refer to figure 13. Connect DR probe heater power leads to DR probe connector.
4. Connect O<sub>2</sub> signal and thermocouple wires to DR probe connector.

**This page intentionally left blank.**

# Wiring Diagrams

## Traditional Architecture with Direct Replacement Probe (no electronics inside)

Figure 13

### Model 6888A Direct Replacement Probe (No Electronics) With Traditional Architecture Xi Electronics

#### Model 6888A Product Matrix

Compare the configuration matrix below to the model number on the probe tag to confirm the features present in this specific probe.

Housing & Electronics	
1HT	Standard Housing, Transmitter Electronics, HART Communications
2HT	Integral Autocal, Transmitter Electronics, HART Communications
4FF	Integral Autocal, Transmitter Electronics, Fieldbus Communications
5DR	Standard Housing, Direct Replacement, No Electronics
6DRY	Standard Housing, Direct Replacement, YEW Electronics

#### Model 6888Xi Product Matrix

Compare the configuration matrix below to the model number on the probe tag to confirm the features present in this specific probe.

Remote Type	
10XY	Single Channel O <sub>2</sub>
20XY	Single Channel O <sub>2</sub> with Flame Safety Interlock for Heater
30XY	Dual Channel O <sub>2</sub>
40XY	Single Channel O <sub>2</sub> , Traditional Architecture for 120V Probes*

**NOTES:**

- SEE INSTRUCTION MANUAL 51-6888Xi FOR ADDITIONAL INSTALLATION AND OPERATING INSTRUCTIONS.
- ALL WIRING MARKED WITH AN ASTERISK (\*) IS FACTORY WIRING INSIDE THE 6888Xi.
- EXCEPT FOR JP7 AND JP8 ON IO BOARD, JUMPER AND SWITCH SETTING ARE FACTORY SET AND ARE SHOWN FOR REFERENCE ONLY.

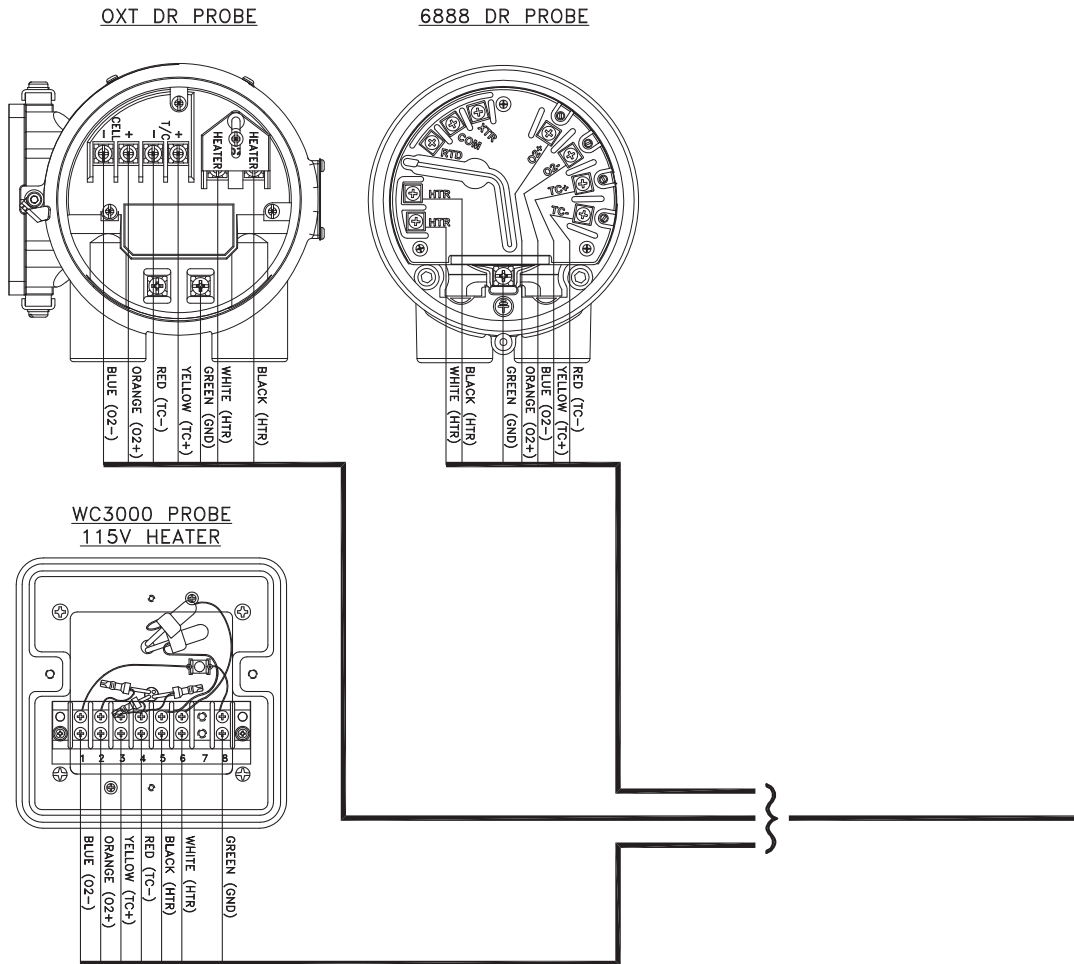

# Wiring Diagrams

## Traditional Architecture with Direct Replacement Probe (no electronics inside)

Figure 13

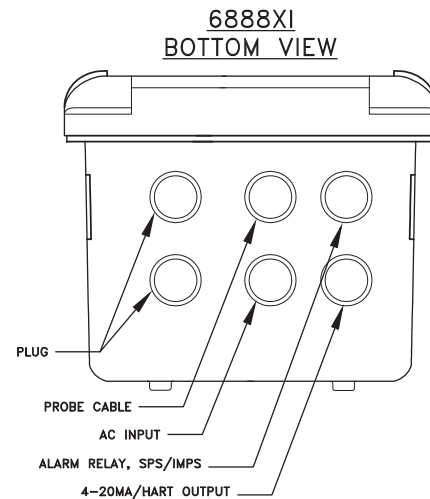
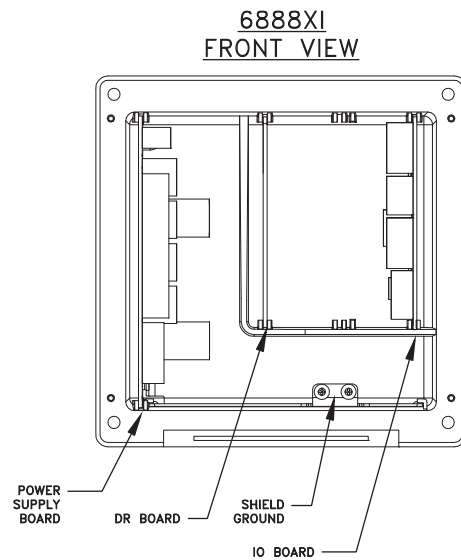
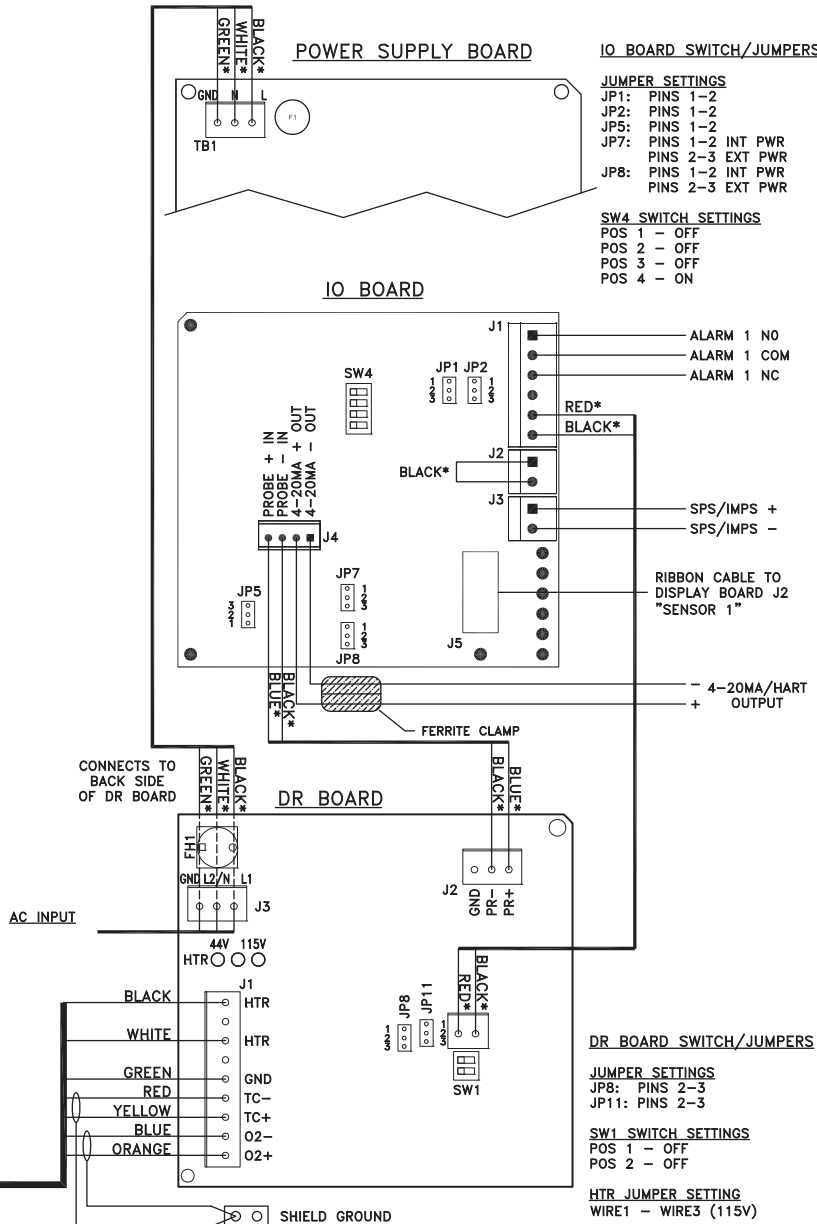

# Wiring Diagrams

## Existing Yokogawa Electronics (must have YEW 6888 probe with cold junction device in the probe terminations.)

Figure 14

### Model 6888A Direct Replacement Probe (No Electronics) With Traditional Architecture Xi Electronics For YEW Probes

#### Model 6888A Product Matrix

Compare the configuration matrix below to the model number on the probe tag to confirm the features present in this specific probe.

Housing & Electronics	
1HT	Standard Housing, Transmitter Electronics, HART Communications
2HT	Integral Autocal, Transmitter Electronics, HART Communications
4FF	Integral Autocal, Transmitter Electronics, Fieldbus Communications
5DR	Standard Housing, Direct Replacement, No Electronics
6DRY	Standard Housing, Direct Replacement, YEW Electronics

#### Model 6888Xi Product Matrix

Compare the configuration matrix below to the model number on the probe tag to confirm the features present in this specific probe.

Remote Type	
10XY	Single Channel O <sub>2</sub>
20XY	Single Channel O <sub>2</sub> , with Flame Safety Interlock for Heater
30XY	Dual Channel O <sub>2</sub>
40XY	Single Channel O <sub>2</sub> , Traditional Architecture for 120V Probes*

- NOTES: 1. Heater temperature set to 1380°F (750°C)
2. The greater mass of the 6888 direct replacement probe requires longer time to heat up. Upon startup, the Yokogawa electronics may indicate an error because the probe has not reached temperature setpoint in the normal time. Remove power from the Yokogawa electronics or probe module to clear the error, and restore power. This procedure may have to be repeated a couple of times before probe operating temperature is reached.

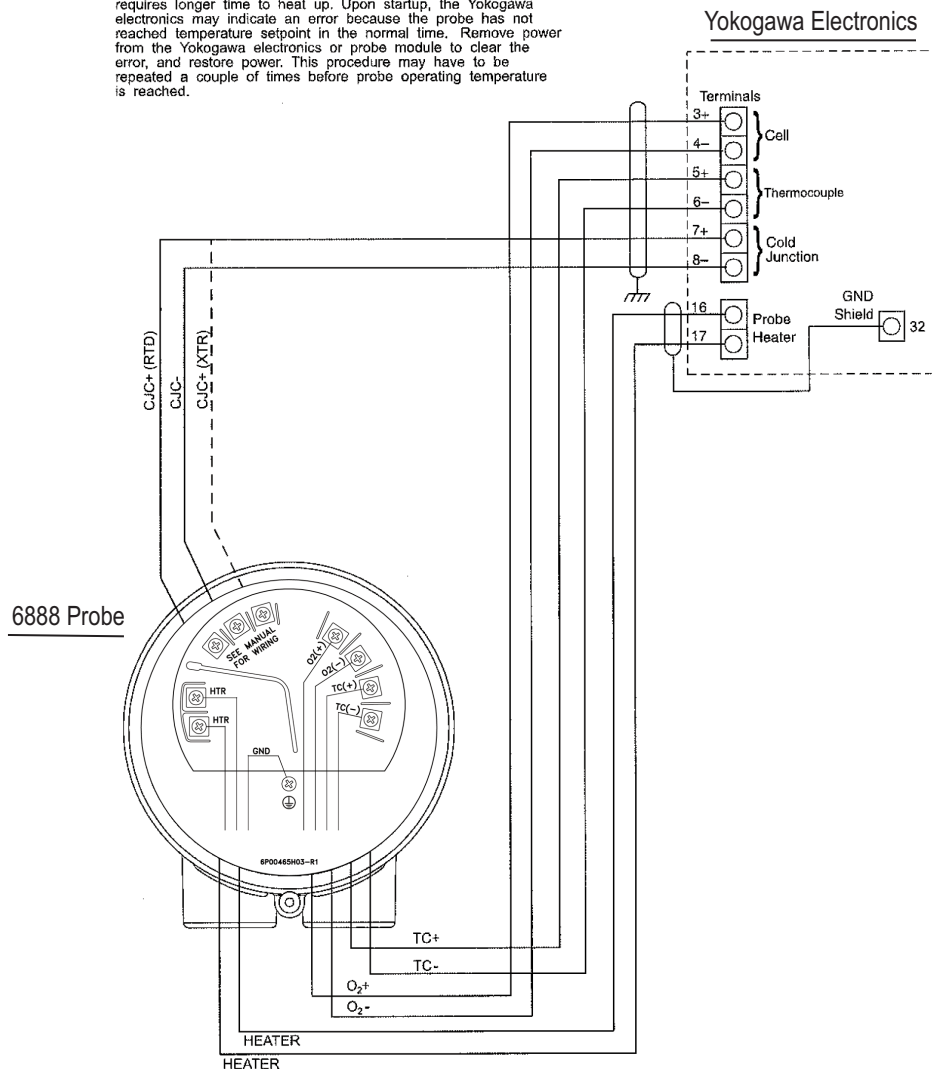

**This page intentionally left blank.**

# Electrical Installation

## Traditional Architecture Cable Connections

A traditional architecture configuration is used to provide for remote location of the transmitter electronics. All electronics are housed inside the 6888Xi. A multi-conductor power/signal cable connects between the probe and the 6888Xi. Use the following procedure to connect the traditional architecture probe to the 6888Xi.

### NOTE

The Traditional Architecture cable is provided at the specified length and is ready for installation. The cable glands must be properly terminated to maintain EMC/EMI noise protection.

1. Run the 7-conductor cable between the traditional architecture probe and the installation site for 6888Xi. Use new cable conduit or trough as needed.
2. Install the cable and lead wires to the probe per manufacturer's instructions.
3. Install the cable at the probe housing and at the 6888Xi enclosure according to the following procedure:
  - a. Unscrew locking nut from gland assembly, Figure 8, and slide locking nut back along cable.
  - b. Pull the gland body away from the plastic insert. Use care not to damage the cable shield braid.
  - c. Insert the cable wires into the proper entry port in either the probe housing or the 6888Xi enclosure.
  - d. At the probe housing, apply Teflon tape or similar sealing compound to the tapered pipe threads. Thread the gland body into the probe housing until properly seated.
  - e. At the 6888Xi enclosure, insert the gland body into the left front cable port from the inside of the enclosure.  
  
Use the rubber O-ring provided to seal the cable port.
  - f. Ensure the cable shield braid is evenly formed over the gray insert. When properly formed, the braid should be evenly spaced around the circumference of the insert and not extend beyond the narrow diameter portion.
  - g. Carefully press the gray insert into the gland body. The grooves on the insert should align with similar grooves inside the gland body. Press the insert in until it bottoms out in the gland body.
  - h. Slide the locking nut up and thread it onto the gland body. Tighten the locking nut so the rubber grommet inside the plastic insert compresses against the cable wall to provide an environmental seal.
4. At the 6888Xi, connect the cable leads to the connectors on the transmitter I/O board as indicated in Figure 13.



Figure 15. Traditional Architecture Cable Gland Assembly

**⚠ WARNING**

Disconnect and lock out power before working on any electrical components. There is voltage up to 240 VAC.

# Pneumatic Installation

## Reference Air Package

After the 6888 is installed, connect the reference air set to the 6888 unit. Refer to the schematic diagram and the mounting dimensions in Figure 16 for a locally assembled reference air supply.

Instrument Air (Reference Air): 5 psi (34 kPa) minimum, 8 psi (54 kPa) maximum at 2.0 scfh (1.0 l/min) maximum; less than 40 parts per million total hydrocarbons. Regulator outlet pressure should be set at 5 psi (34 kPa). Reference air is recommended, or the reference air fittings can be left open to atmosphere. SPS 4001B or IMPS 4000 autocal boxes contain reference air sets.

Figure 16. Plant Air Schematic Diagram, Standard Housing

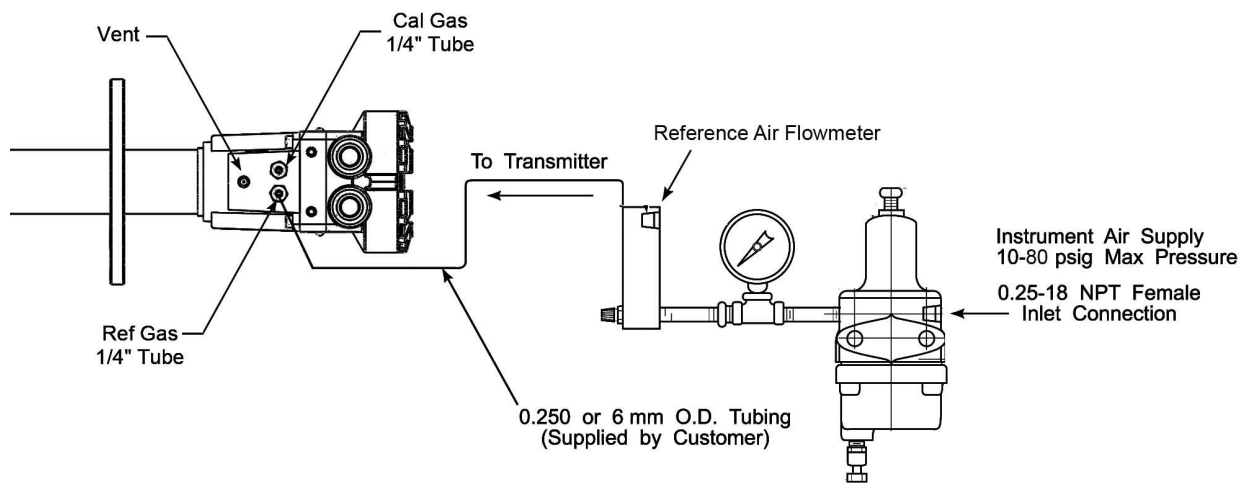
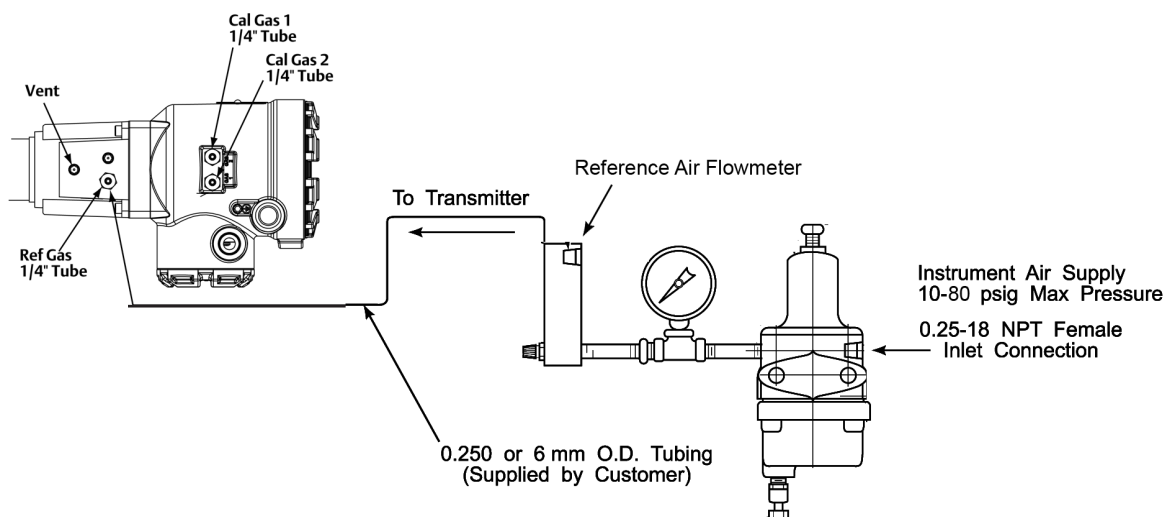

Figure 17. Plant Air Schematic Diagram, Accessory Housing



# Power Up Procedure

## 6888 Transmitter Without 6888XI

1. Apply AC line power to the Transmitter.
2. Apply 24 VDC loop power to the Transmitter.
3. Using either the DCS control or a Field Communicator, verify communications to the Transmitter.
4. The transmitter probe will take approximately 45 minutes to warm up to the 736°C heater setpoint. The 4-20 mA signal will remain at a default value of 3.5 mA and the O<sub>2</sub> reading will remain at 0% through this warm-up period. After warm up, the probe will begin reading oxygen and the 4-20 mA output will be based on the default range of 0-10% O<sub>2</sub>.
5. If there is an error condition at startup, an alarm message will be displayed. Refer to full instruction manual for troubleshooting alarms.

## Power Up Procedure

### 6888 Transmitter With Single/Dual Channel or Single Channel & Flame Safety Interlock 6888Xi

1. Apply AC line power to the Transmitter.
2. Apply AC line power to 6888Xi. Run the Quick Start Wizard as described below. At the “Auto Cal Device” screen select the calibration method based on the 6888 Transmitter as follows:
  - a. Standard Probe Housing Configuration – Select **None**, **SPS** or **IMPS** as appropriate. Do not select **Integral** or calibration will not be possible.
  - b. Integral Autocal Probe housing – Select **Integral** only. If **Integral** is not selected, calibration will not be possible.
3. Verify communications between the Transmitter and the 6888Xi. The 6888Xi display is preconfigured to display O<sub>2</sub> & cell temperature for single channel configurations and both O<sub>2</sub> readings for dual channel configurations.
4. The transmitter probes will take approximately 45 minutes to warm up to the 736°C heater setpoint. The 4-20 mA signal will remain at a default value of 3.5 mA and the O<sub>2</sub> reading will remain at 0% through this warm-up period. After warm up, the probe will begin reading oxygen and the 4-20 mA output will be based on the default range of 0-10% O<sub>2</sub>.
5. If there is an error condition at startup, an alarm message will be displayed on the 6888Xi. Refer to full instruction manual for troubleshooting alarms.

### 6888 Direct Replacement Probe (no electronics inside) With Traditional Architecture 6888Xi

1. Apply AC line power to 6888Xi. Run the Quick Start Wizard as described below. At the “Auto Cal Device” screen select **None**, **SPS** or **IMPS** as appropriate. Do not select **Integral** or calibration will not be possible.
2. The direct replacement probe will take approximately 45 minutes to warm up to the 736°C heater setpoint. The 4-20 mA signal will remain at a default value of 3.5 mA and the O<sub>2</sub> reading will remain at 0% through this warm-up period. After warm up, the probe will begin reading oxygen and the 4-20 mA output will be based on the default range of 0-10% O<sub>2</sub>.
3. If there is an error condition at startup, an alarm message will be displayed on the 6888Xi. Refer to full instruction manual for troubleshooting alarms.

# Power Up Procedure

## 6888Xi Quick Start Wizard

When the 6888Xi is first powered, a short wizard program will guide the user through the basic setup. Once configured, the 6888Xi will retain the setup and the wizard will not repeat.

1. Apply power to 6888Xi. Once boot-up is complete, the “Quick Start” wizard screen will appear. With a dual channel 6888Xi, the wizard will run for both channels in succession. Press the <Enter> key to continue.
2. At the “Sensor Type” screen, use the Up/Down keys to select “O2”. Do not select “CO” as this option is reserved for future use. Press the <Enter> key to continue.
3. At the “Device Type” screen, use the Up/Down keys to select HART or FF (FOUNDATION Fieldbus), whichever applies.
4. At the “Auto Cal Device” screen, use the Up/Down keys to select the calibration method to be used. The methods are defined as follows:
  - None** – Manual calibration with the standard probe housing configuration
  - SPS** – Automatic calibration with the standard probe housing configuration using the SPS4001B
  - IMPS** – Automatic calibration with the standard probe housing configuration using the IMPS
  - Integral** – Automatic calibration with the integral autocal probe housing configuration

Press the <Enter> key to continue.

NOTE: If SPS, IMPS or Integral is selected, the user must still configure automatic calibration as “On”. Other parameter such as test gas values and gas times should be verified as well. Refer to 6888Xi full instruction manual for calibration setup details.

5. When prompted if “Setup Correct?”, use the Up/Down keys to select “Yes”. If “No” is selected, the wizard will restart. Press the <Enter> key to continue.
6. The 6888Xi will display several screens while saving the configuration, reset itself then return to the main screen.

## Re-initiating 6888Xi Wizard

To re-initiate the wizard setup, the IO board must be reset to factory default conditions.

1. Apply power to 6888Xi.
2. When the main screen appears, press the <Menu> key several times until the “System” menu appears. Use the Up/Down keys to select “Configure IOB”. Press the <Enter> key to continue.
3. When the configure IOB screen appears, use the Up/Down keys to select “I/O Board 1”. With a dual channel 6888Xi, either or both I/O boards may be reset and reconfigured. Press the <Enter> key to continue.

# Power Up Procedure

## 6888Xi Quick Start Wizard (continued)

4. When the I/O board 1 menu appears, use the Up/Down keys to select “Reset I/O Board”. Press the <Enter> key to continue.
5. When the reset menu appears, use the Up/Down keys to select “Factory Defaults”. Press the <Enter> key to continue.
6. When prompted, use the Up/Down keys to select “Yes”. Press the <Enter> key to continue.
7. The 6888Xi will display several screens while saving the configuration, reset itself then display the wizard screen.

# Calibration

The 6888 O<sub>2</sub> analyzer system can be calibrated in the installed condition without removing the instrument from the process duct and also while the combustion process is on-line. A stainless steel tube runs the length of the probe, and delivers the calibration gasses into the cell area. Factory calibration will usually be satisfactory for initial start-up and operation, but most accurate measurement is gained by executing a calibration under normal operating conditions.

Recommended calibration gases are 0.4% O<sub>2</sub> and 8% O<sub>2</sub>, with the balance of nitrogen in the gas bottles, but other values can be used as long as the electronics are configured identically. Instrument air or pure nitrogen are not recommended as calibration gas values. A two-stage pressure regulator should be used to establish a pressure of 20 PSI, from the bottles, and the flowmeter should be set to 5 SCFH flow rate.

## Manual/Semi-automatic Calibration

The 6888 probe with the standard housing can be calibrated in a semi-automatic fashion, with a technician following prompts via the display of the Xi electronics or via HART communications to a 475 handheld communicator or AMS console. The technician will need to manually switch the gases based upon these prompts. Recommended calibration gases are 0.4% O<sub>2</sub> and 8% O<sub>2</sub>, balance nitrogen. A two-stage pressure regulator should always be used, set to 20 PSI. The calibration gas flowmeter should be set for 5 SCFH, with the cal gas fitting removed from the probe. A diffuser/filter that is plugged over time may cause the flowmeter to deliver less flow to the sensing cell, but the flow rate should never be readjusted until a new diffuser is installed. Readjusting the flowmeter back up to the 5 SCFH level could pressurize the cell during calibration, and cause the O<sub>2</sub> reading to shift downwards.

The electronics will determine if the calibration was successful, and calculate new calibration values. New calibration values are not automatically loaded into the electronics after a successful calibration, however. The technician has the opportunity of accepting the new values or not. (A significant calibration change may cause a bump in the O<sub>2</sub> readings at the DCS console, causing the operator concern). Record the calibration data on the log provided (cell slope, constant, and impedance, as well as the speed of response data). If the electronics ps used, it will store calibration data for the past 10 successful calibrations.

### ⚠ CAUTION

Make sure that the calibration gas cap is replaced tightly after calibration is complete. Many combustion processes operate at a slight negative pressure (draft pressure), and can draw ambient air down the cal gas lines and into the sensing cell, causing a false elevated O<sub>2</sub> reading. This same phenomenon is possible if the calibration gas hoses are permitted to become degraded or loose.

## Fully Automatic Calibration

Fully automatic calibration requires the Xi electronics to manage the actuation of solenoids to introduce gases into the probe.

### 6888 Probes with Standard Electronics Housing

In addition to the Xi, this arrangement requires a separate Single Probe Sequencer (SPS), which is a solenoid box for switching calibration gases, or a larger Intelligent Multiprobe Sequencer (IMPS), which can handle the autocal for up to 4 probes in one box.

The automatic calibrations can be initiated in several ways:

- Via a “calibration recommended” diagnostic that is periodically checking cell impedance
- Via pushbutton on the Xi electronics
- Via HART communications from a 475 handheld communicator, or AMS
- Via an external contact closure
- Via time since the last successful calibration

**Note:** To manually initiate an automatic calibration, select 9999 for “CAL INTERVAL in the setup menu.

**If the O<sub>2</sub> measurement is being used for automatic control, always place the O<sub>2</sub> control loop into manual prior to calibrating. Always inform the operator prior to calibrating. The Xi electronics provides an “in cal” contact closure for this purpose. An “intiate cal” contact is also provided.**

The Xi electronics will sequence the calibration gases in turn into the sensing cell. A 300 second flow time is the factory default for both gases, and also for the purge cycle, which lets the probe signal come back to the normal flue gas readings. The 4-20 Ma signal representing O<sub>2</sub> can be held during the calibration cycle, or permitted to vary with the bottled gases, in which case a record of the calibration can be trended at the DCS.

Calibration setup is found under the detailed setup menu.

## 6888 Probe with Integral Autocal Housing

This probe contains the autocal solenoids within the blue electronics housing, eliminating the need and cost for an SPS or IMPS solenoid enclosure. Both calibration gases are permanently piped into two ports on the probe. It's important to confirm that there are no piping leaks, or the calibration bottles will leak down prematurely.

**Note 1:** The calibration sequence from the Xi electronics will be identical to that for the manual/semiautomatic calibration, but **note that with the integral autocal version of this probe it is not possible to conduct a manual calibration.** The factory offers a probe rebuild capability if solenoid or other failures occur.

**Note 2:** Calibration gas bottle will be piped and under pressure at all times, so be sure to leak-check all fittings, tubing and connections. Always use dual-stage pressure regulators.

## Other Features Associated with Calibration

1) "Cal Check" capability. A user can choose to look at new calibration values prior to having them load in and become active. If this feature is selected, a "calibration changed" alarm will come up after the calibration is complete. By pushing the "Diagnostics" button on the Xi, an "Accept Cal" step can be required so that the technician and operator can decide if they are ready to accept a potentially large change in calibration values.

2) Plugged Diffuser Diagnostic- this feature measures the return-to-process rate after calibration gases are removed, and will alarm when this time exceeds 75% of the purge time configured. A "purge time too short" alarm is an indication that the diagnostic could not work because of a short purge time, and is another indication that the diffuser is plugged. Purge time should be increased in this case.

Another feature that comes with the Plugged Diffuser Diagnostic is Auto Gas Switching. This feature switches cal gases, and also ends the purge sequence when the readings settle out, vs. waiting for a configured flow time. This saves time and gas.

3) Tolerance Check that will alarm if the cell MV signal is significantly different than the expected signal of the bottles noted in the setup. This will indicate if the wrong bottles are being used, or if a bottle runs out in the middle of a calibration.

Calibration Setup is under the Detailed Setup menu.

Calibration set-up can be found in the Xi menu :

Factory default menu see figure 18.

Figure 18. Calibration Defaults

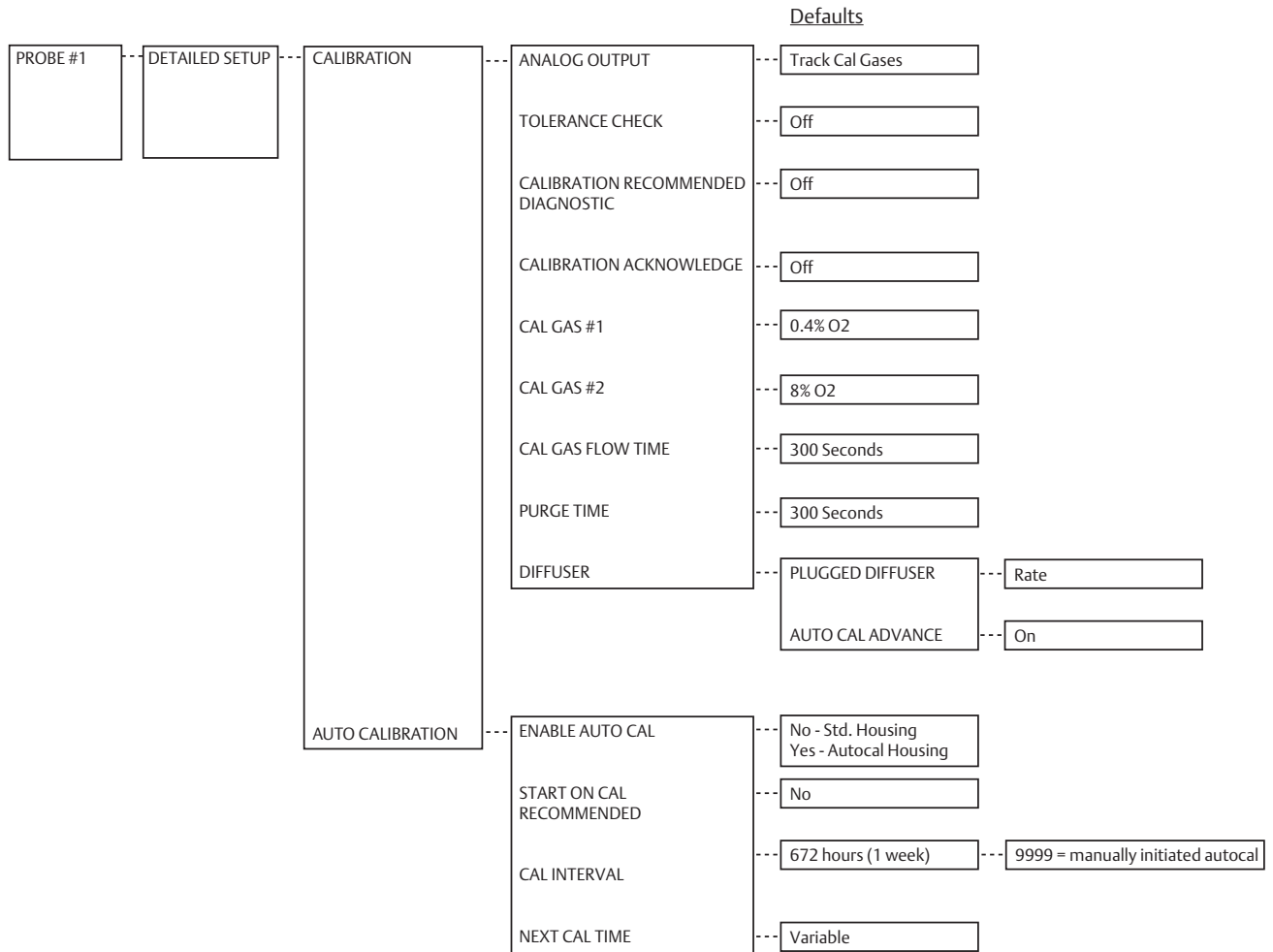

Full menu maps begin on page 54.

# HART Menu Trees

## 6888 Xi

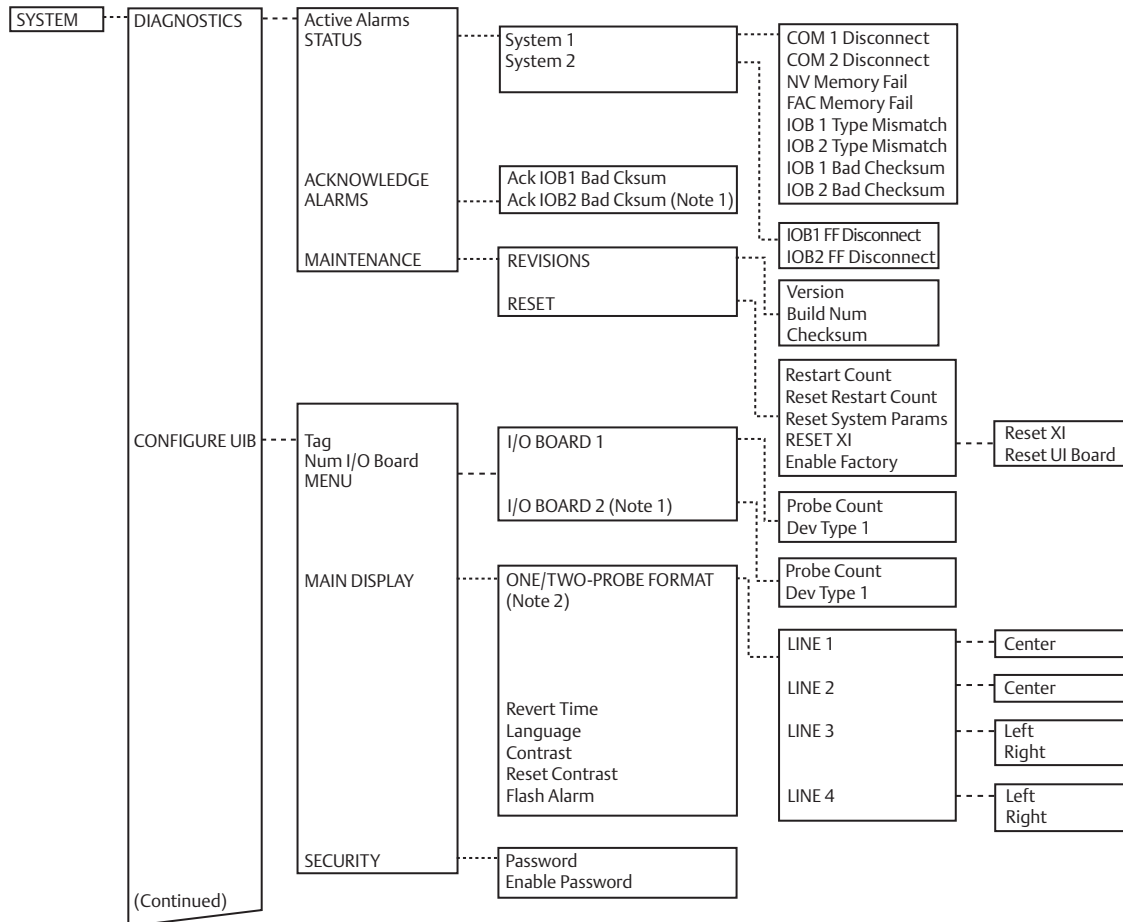

# HART Menu Trees

## 6888 Xi

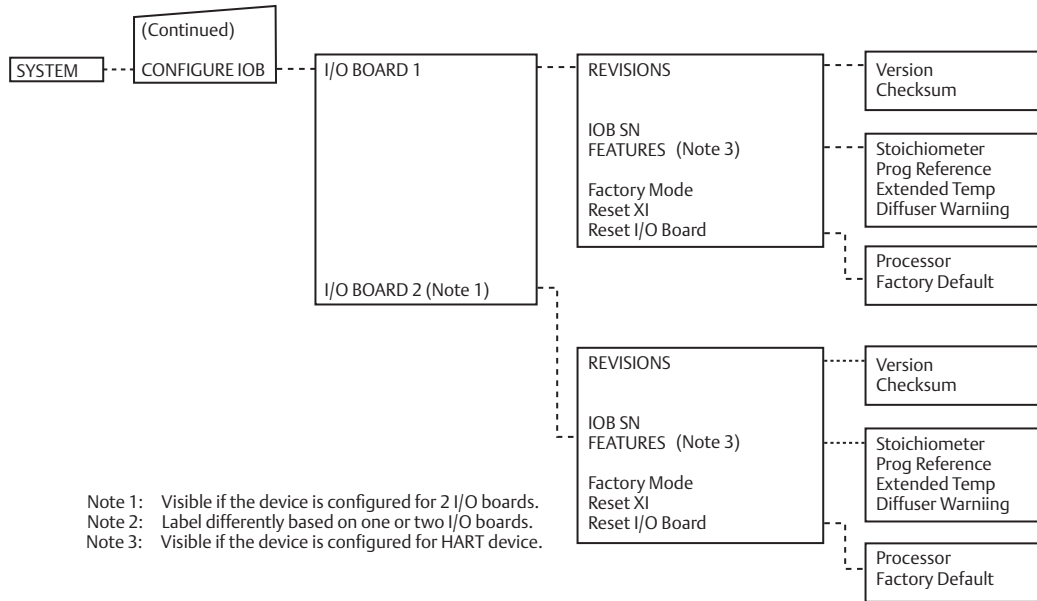

# HART Menu Trees

## 6888 Xi

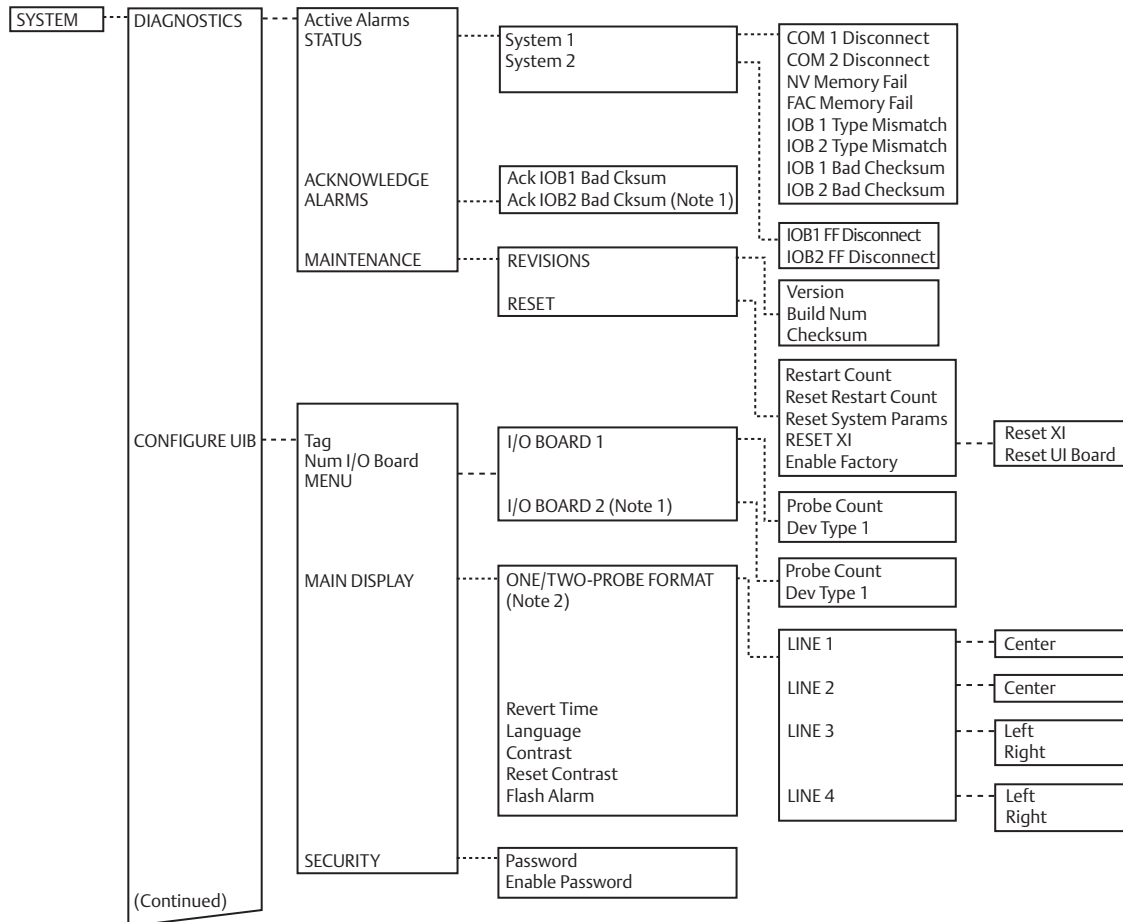

# HART Menu Trees

## 6888 Xi

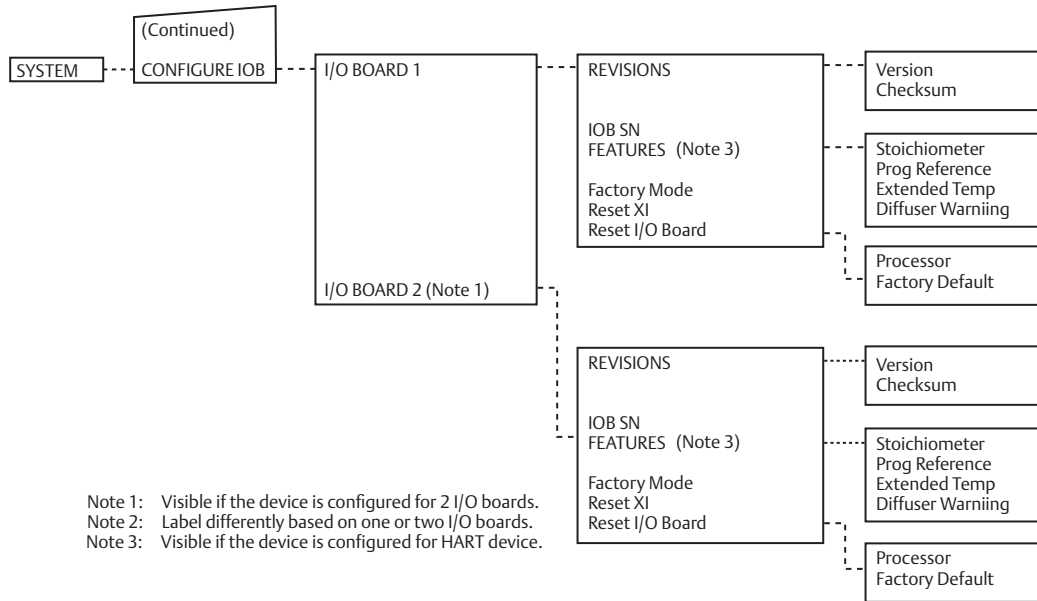

# HART Menu Trees

## 6888 Xi

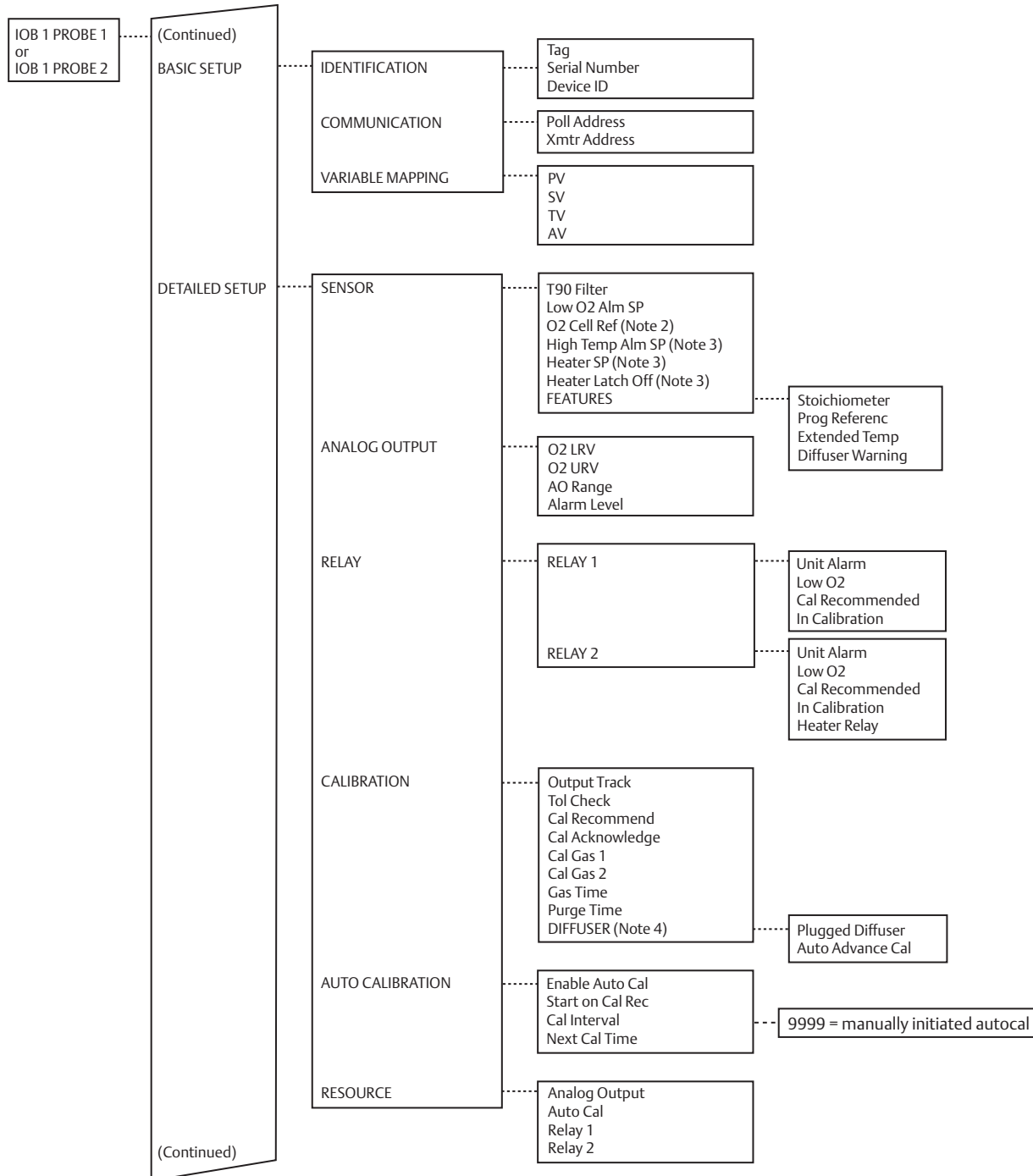

# HART Menu Trees

## 6888 Xi

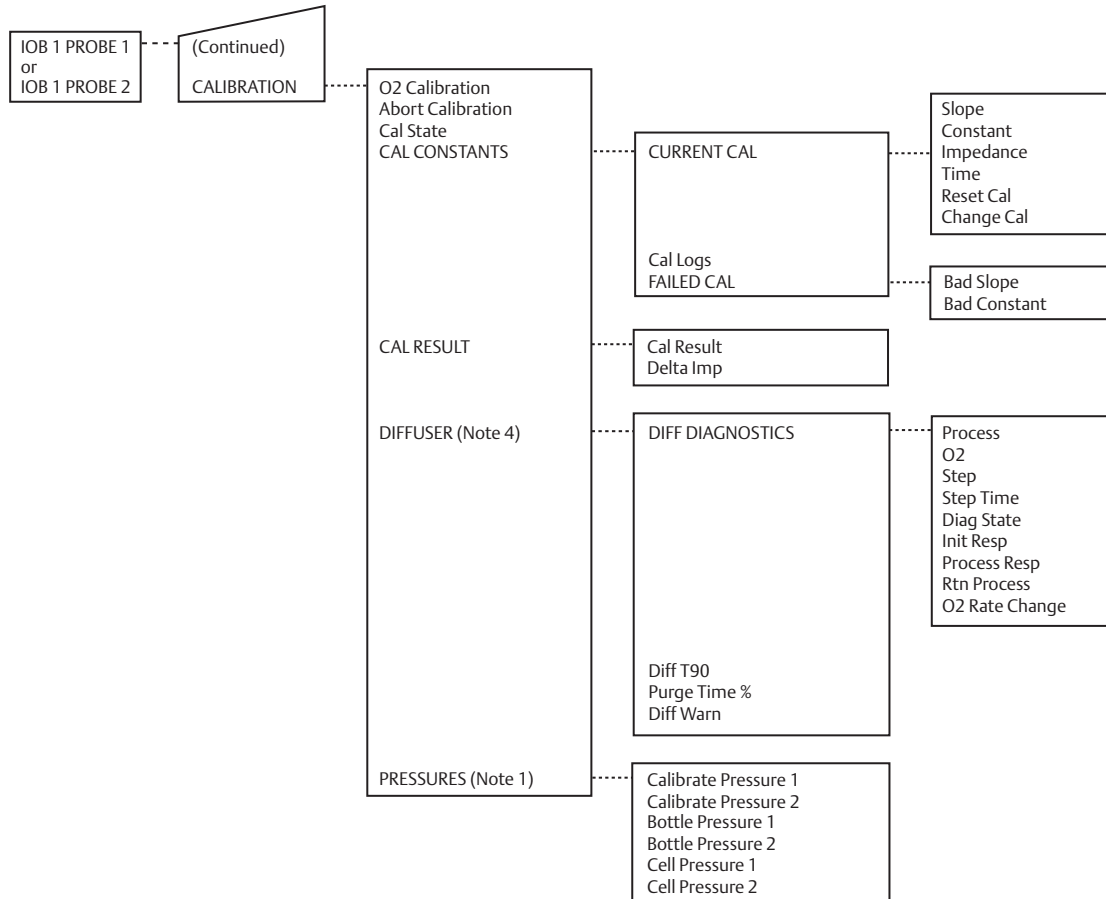

- Note 1: Visible if the device is configured for HSPS Autocal.
- Note 2: Visible if the Programmable Reference software feature is enabled.
- Note 3: Visible if the Extended Temperature software feature is enabled.
- Note 4: Visible if the Diffuser Warning software feature is enabled.

# HART Menu Trees

## 375/475 Field Communicator

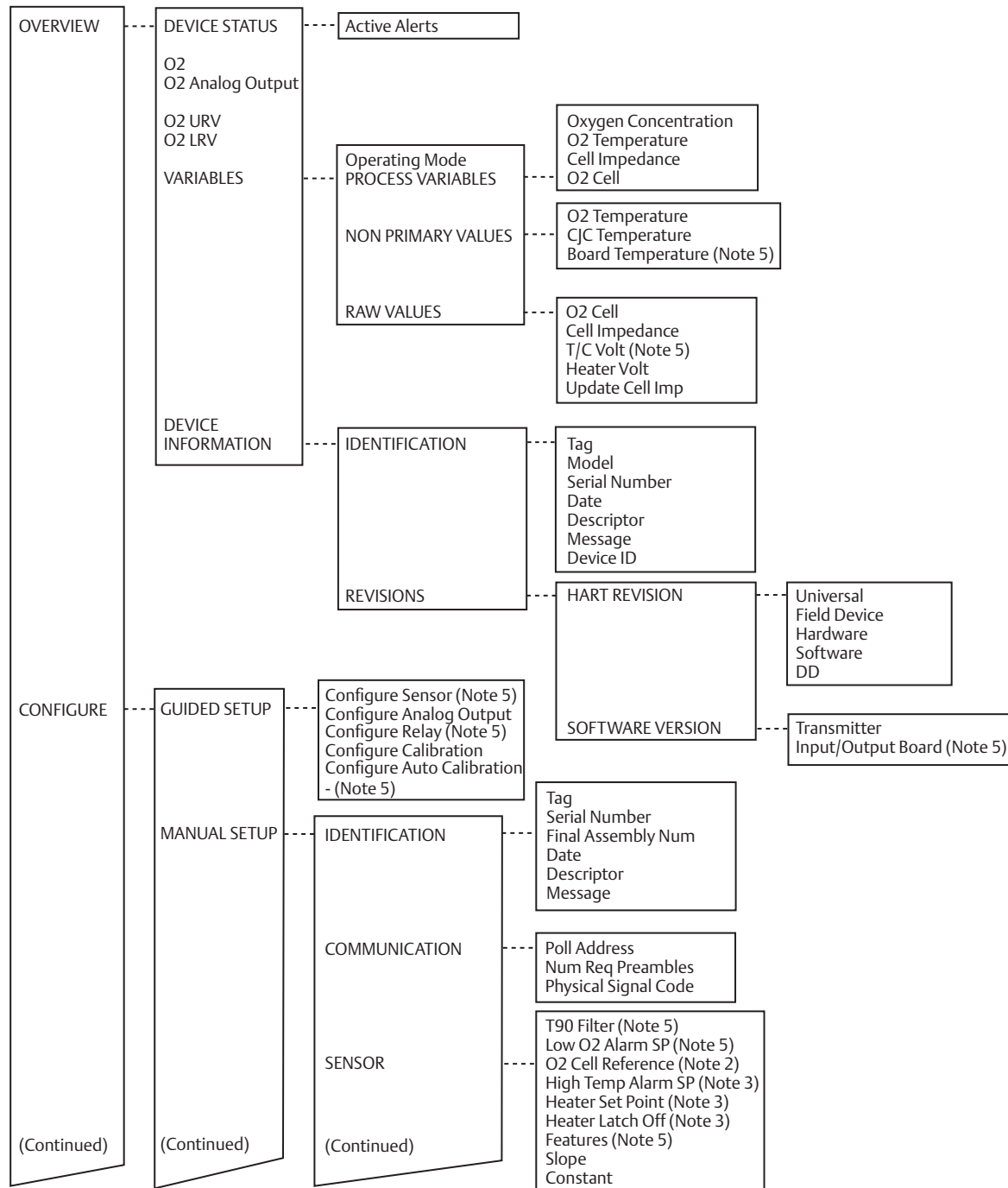

# HART Menu Trees

## 375/475 Field Communicator

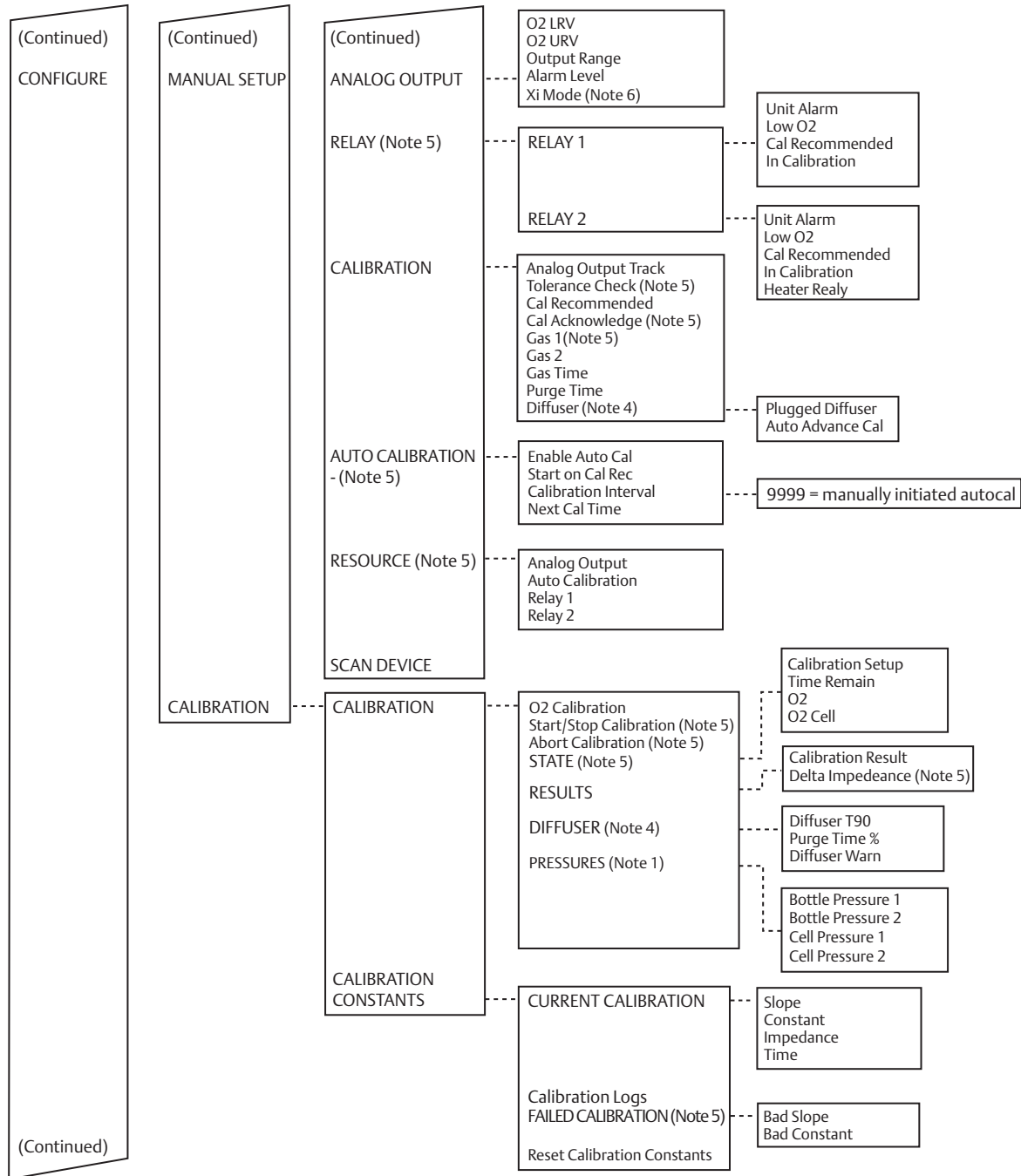

# HART Menu Trees

## 375/475 Field Communicator

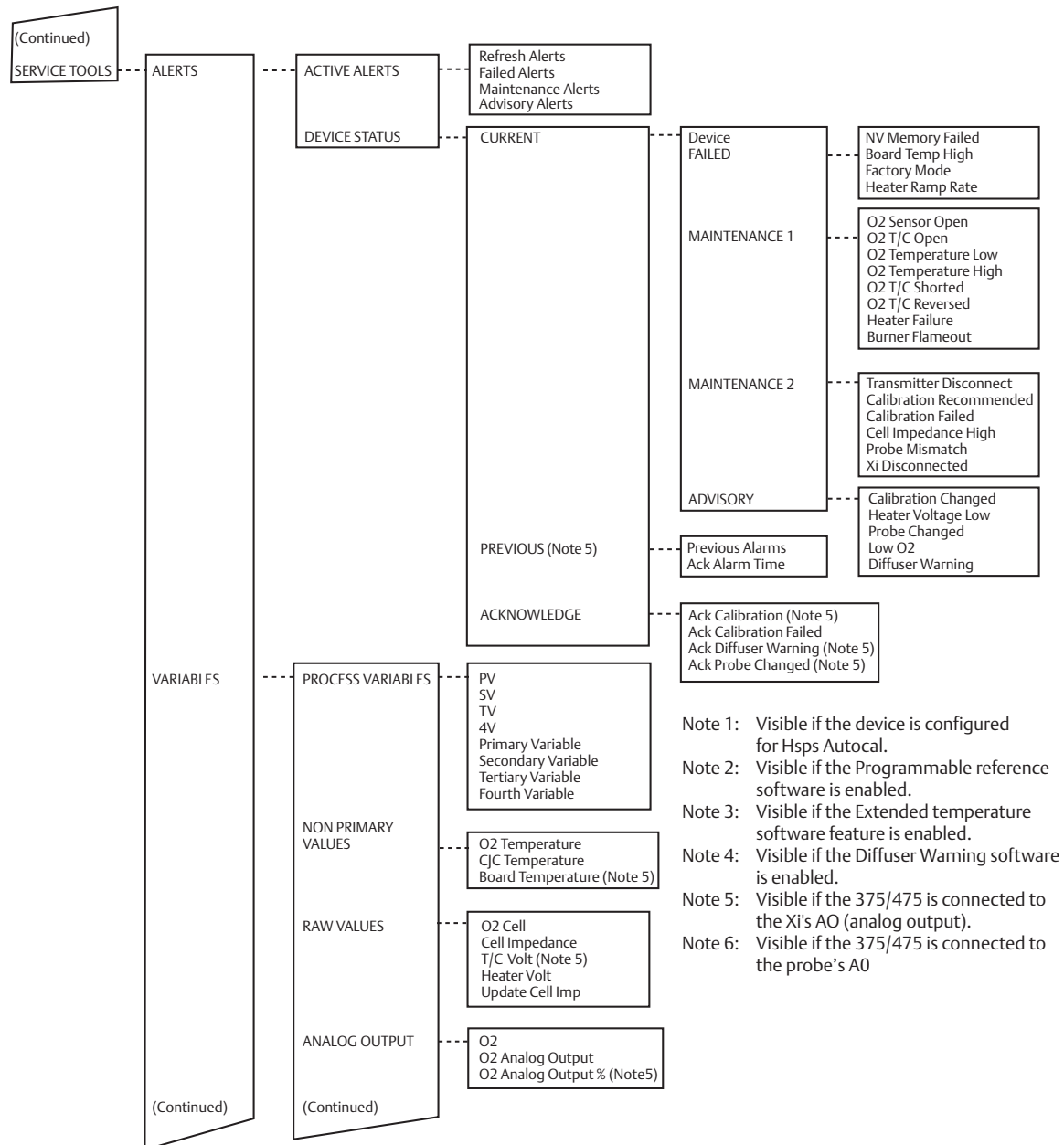

- Note 1: Visible if the device is configured for Hsps Autocal.
- Note 2: Visible if the Programmable reference software is enabled.
- Note 3: Visible if the Extended temperature software feature is enabled.
- Note 4: Visible if the Diffuser Warning software is enabled.
- Note 5: Visible if the 375/475 is connected to the Xi's AO (analog output).
- Note 6: Visible if the 375/475 is connected to the probe's A0

# HART Menu Trees

## 375/475 Field Communicator

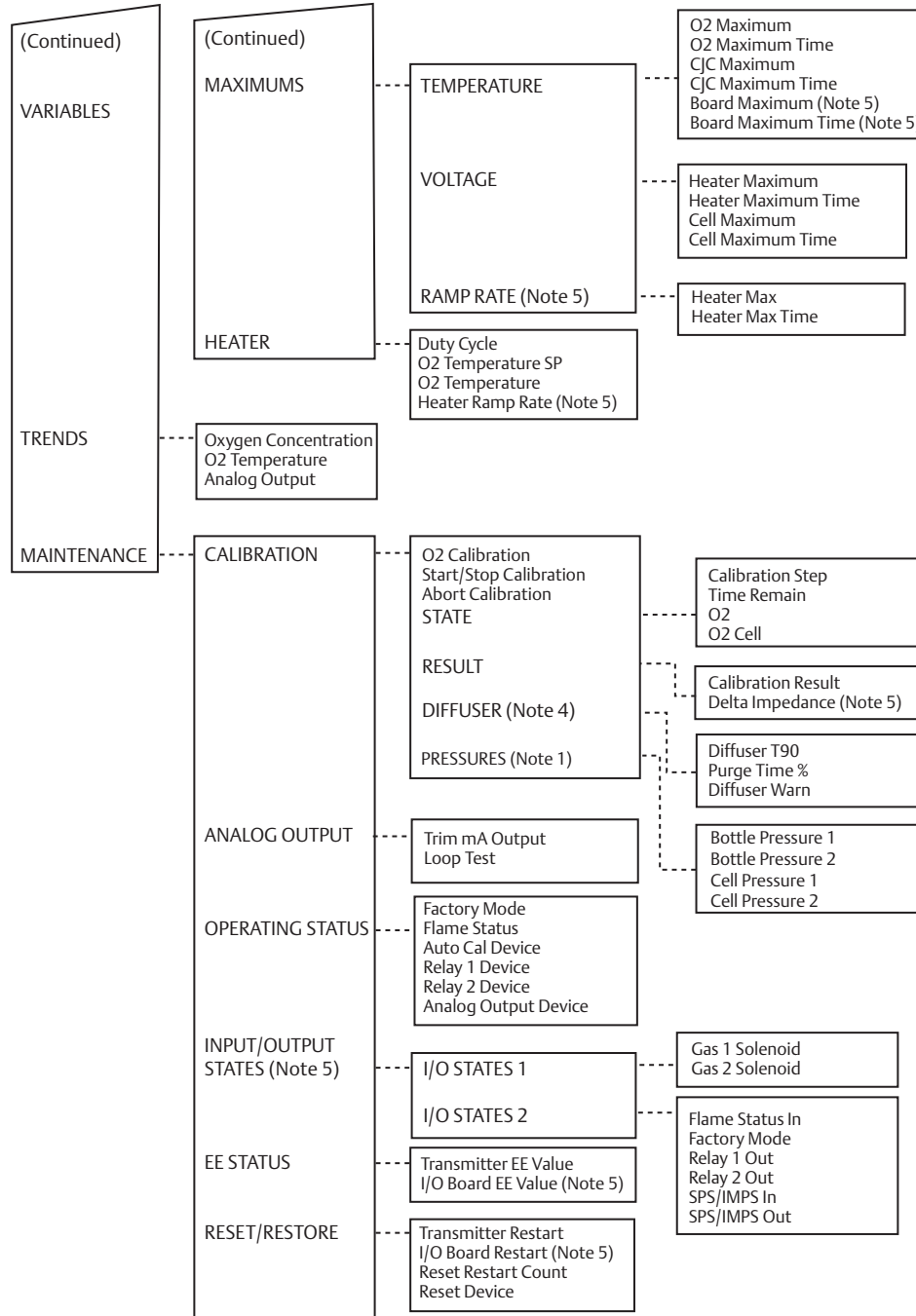

# Foundation Fieldbus Menu Trees

## 6888 Xi

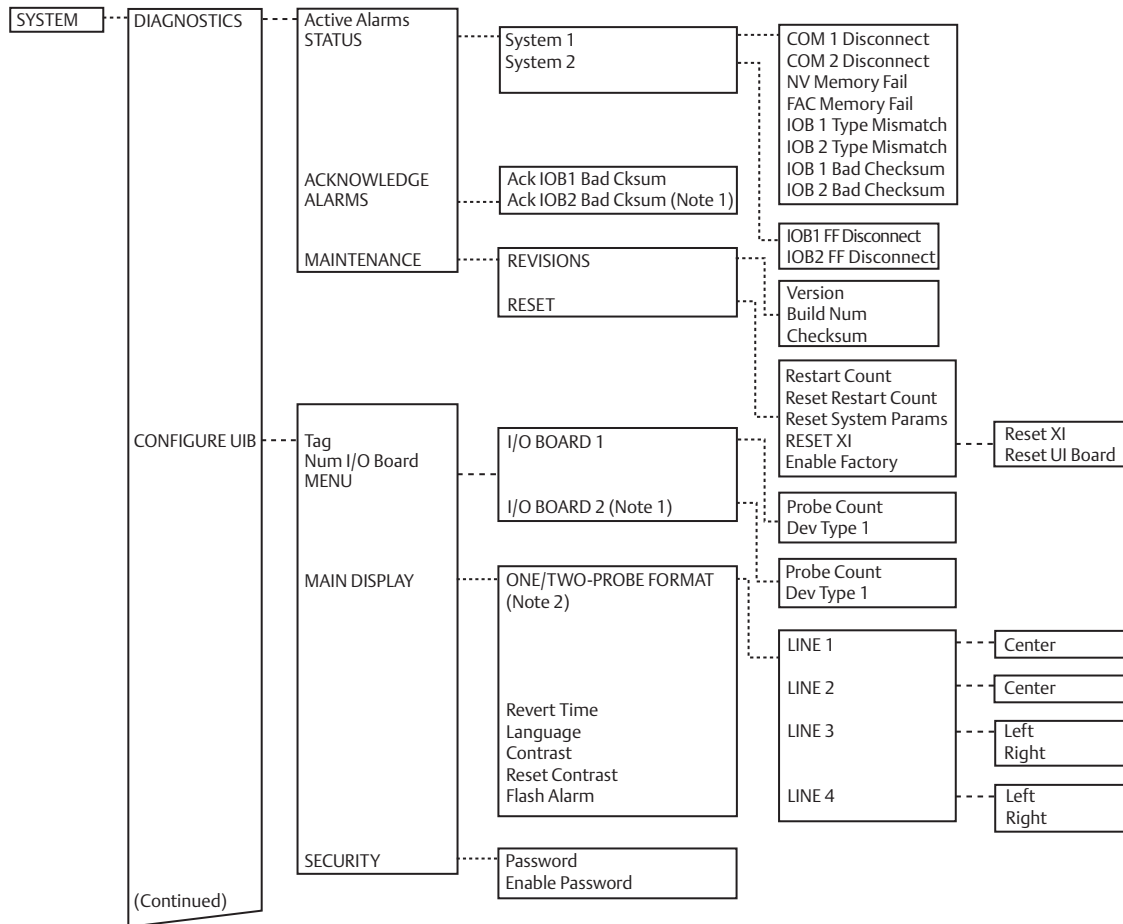

# Foundation Fieldbus Menu Trees

## 6888 Xi

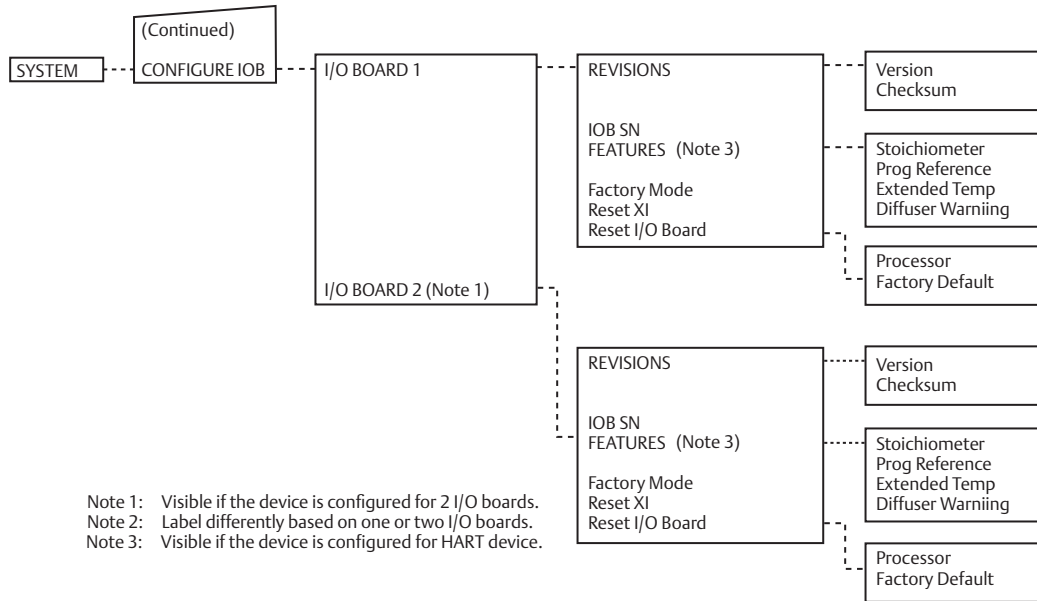

# Foundation Fieldbus Menu Trees

## 6888 Xi

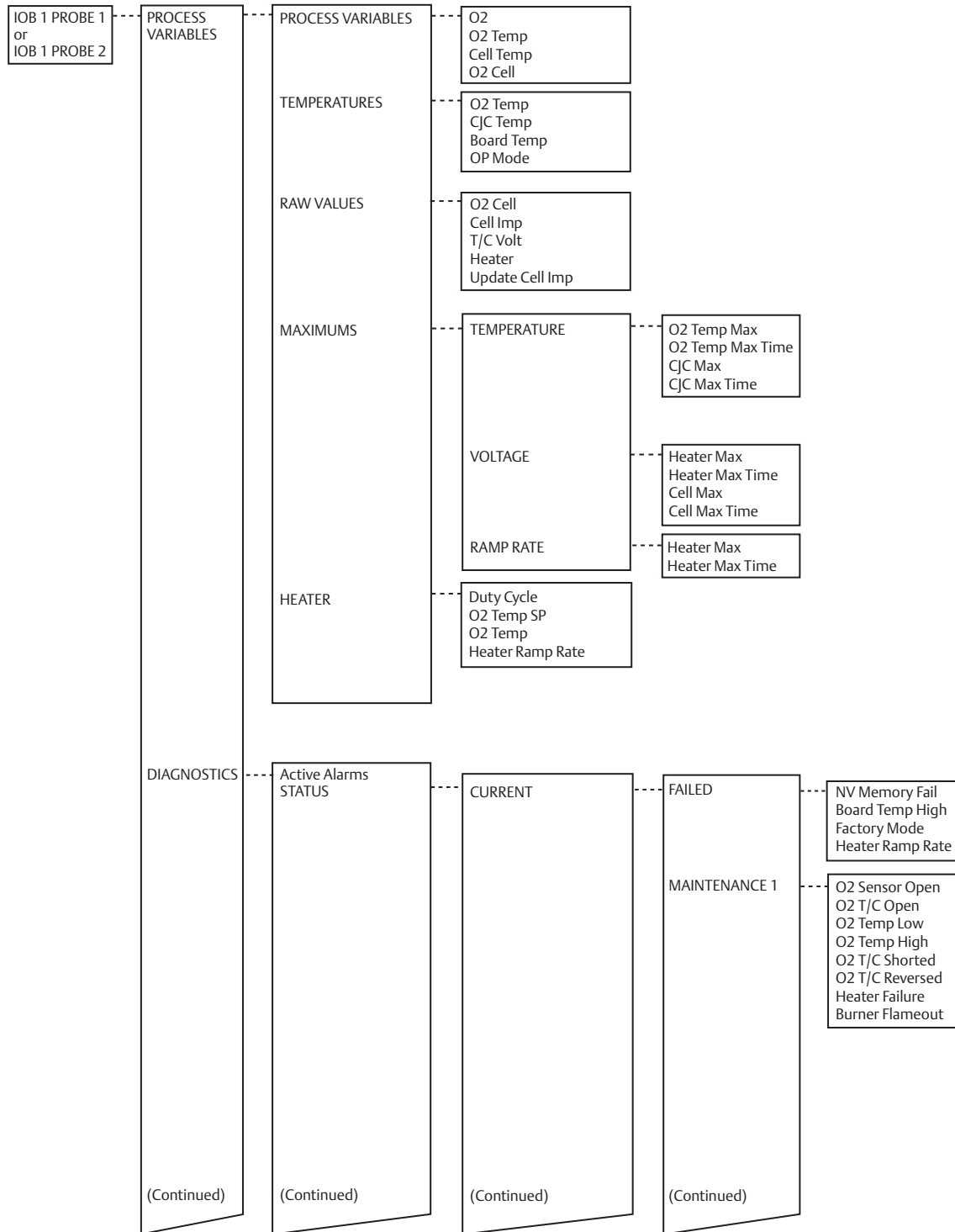

# Foundation Fieldbus Menu Trees

## 6888 Xi

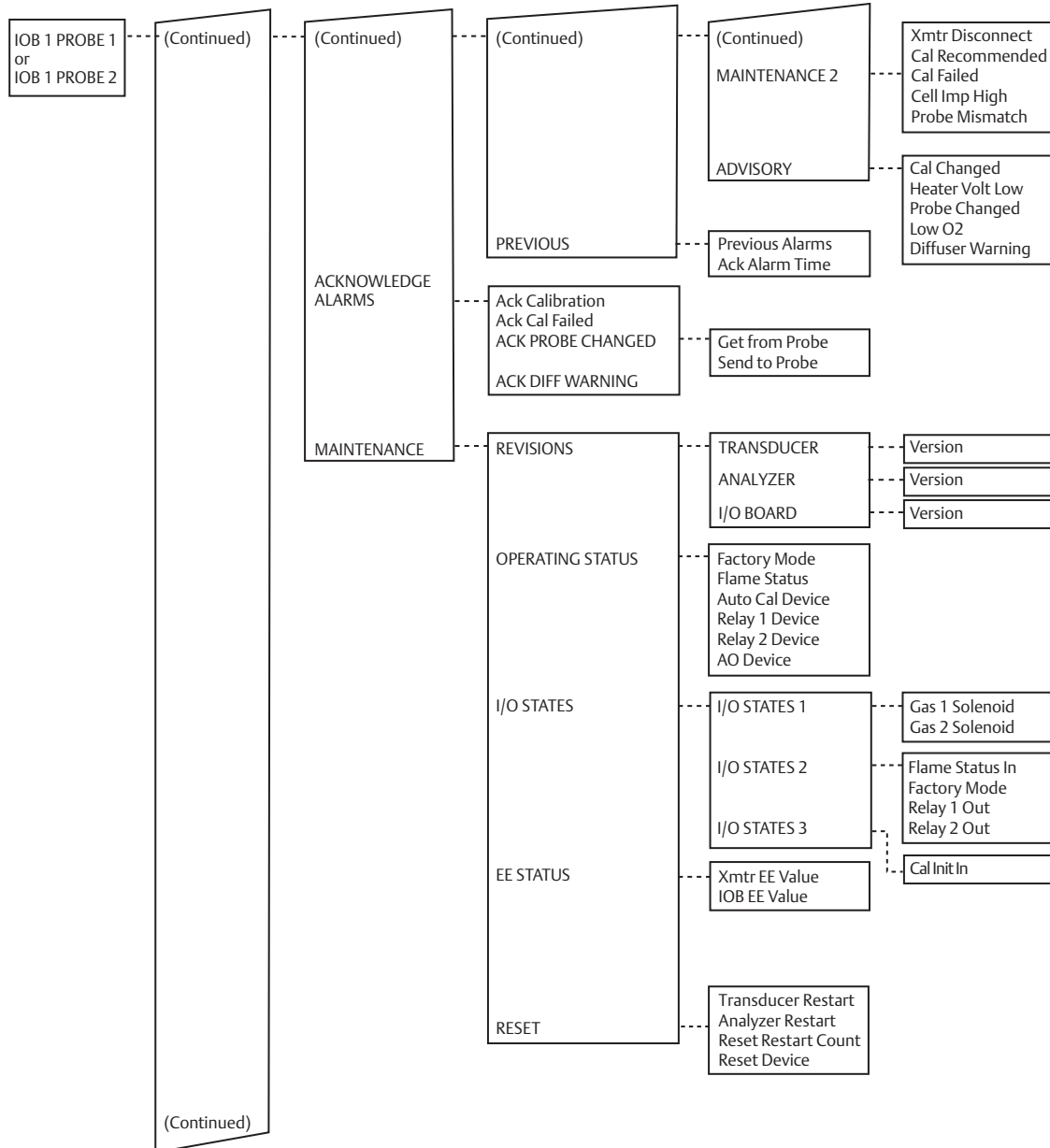

# Foundation Fieldbus Menu Trees

## 6888 Xi

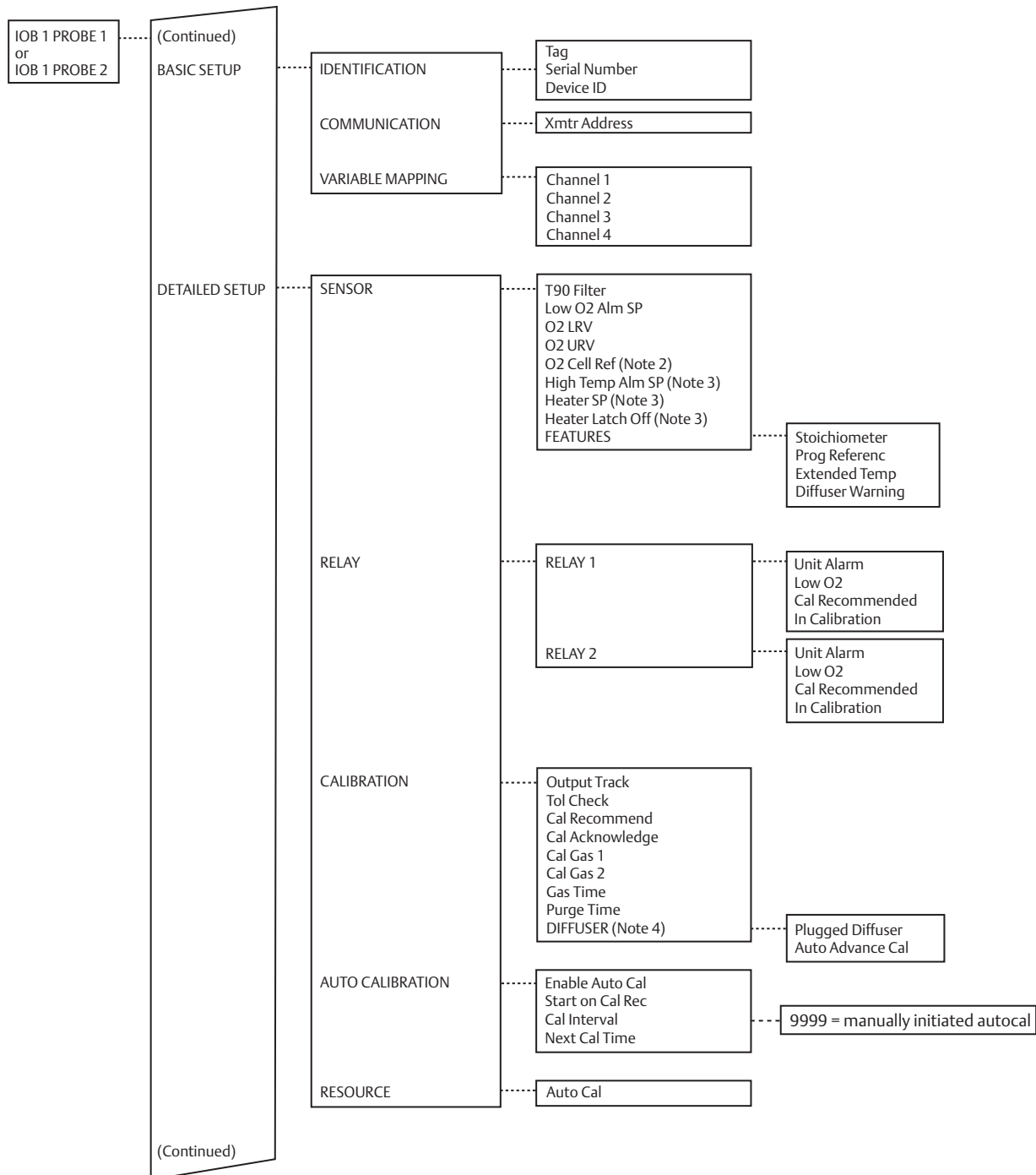

# Foundation Fieldbus Menu Trees

## 6888 Xi

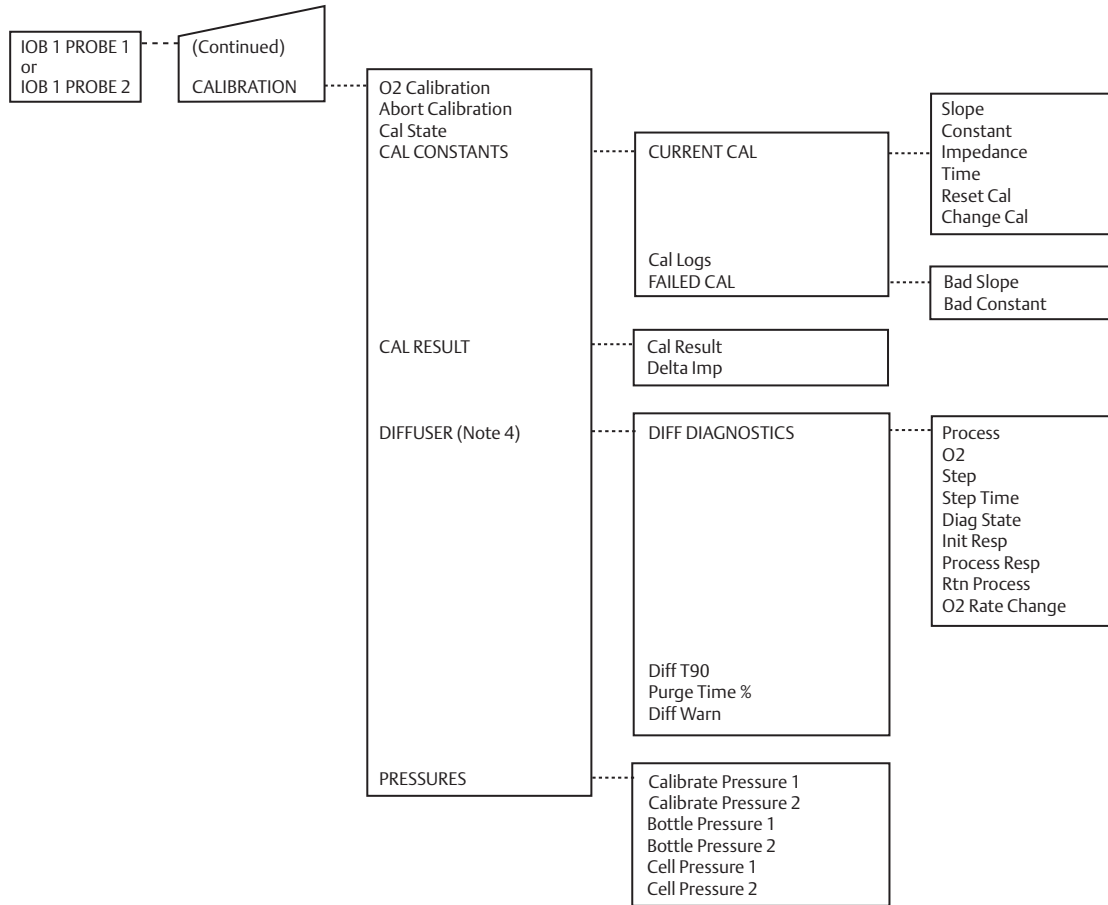

- Note 1: N/A
- Note 2: Visible if the Programmable Reference software feature is enabled.
- Note 3: Visible if the Extended Temperature software feature is enabled.
- Note 4: Visible if the Diffuser Warning software feature is enabled.
- Note 5: Visible if the Factory Mode switch is on.

# Foundation Fieldbus Menu Trees

## 375/475 Field Communicator

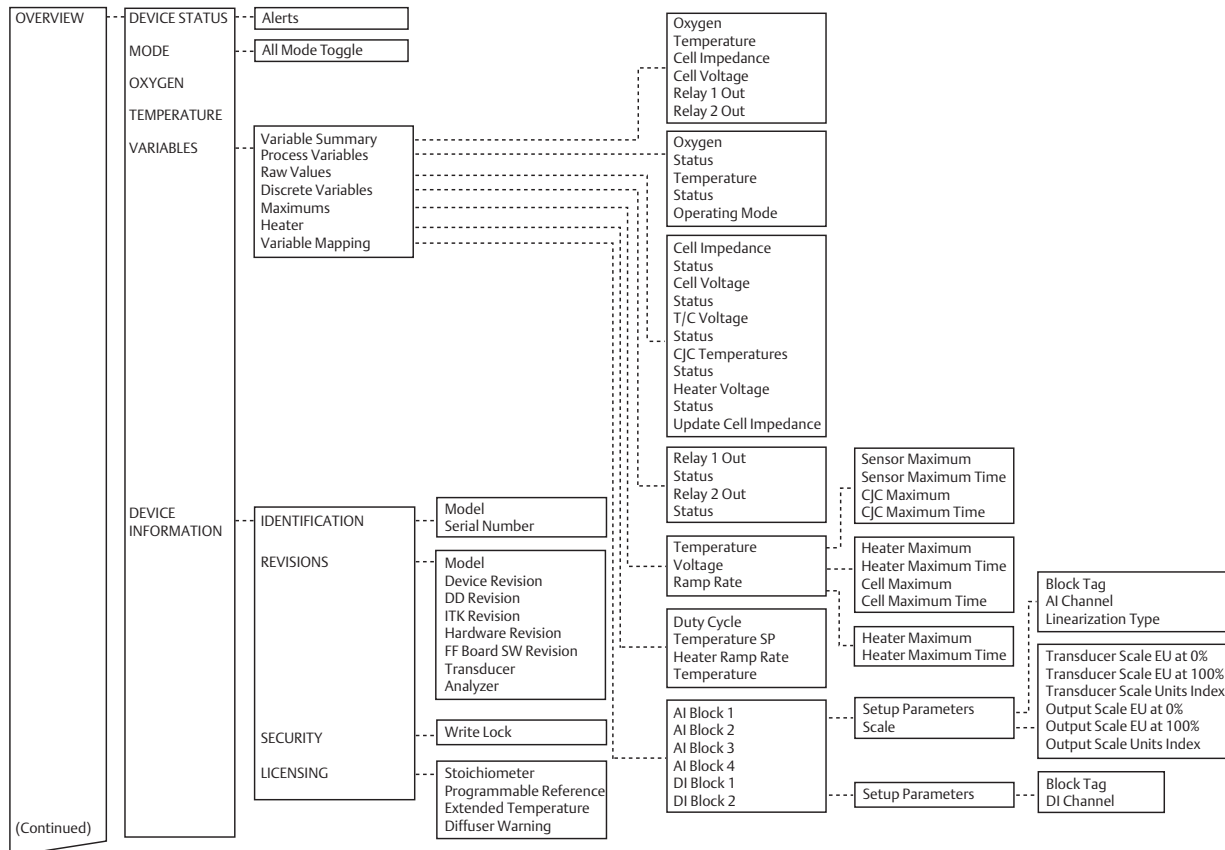

- Note 1: N/A
- Note 2: Visible if the Programmable Reference software feature is enabled.
- Note 3: Visible if the Extended Temperature software is enabled.
- Note 4: Visible if the Diffuser Warning software feature is enabled.

# Foundation Fieldbus Menu Trees

## 375/475 Field Communicator

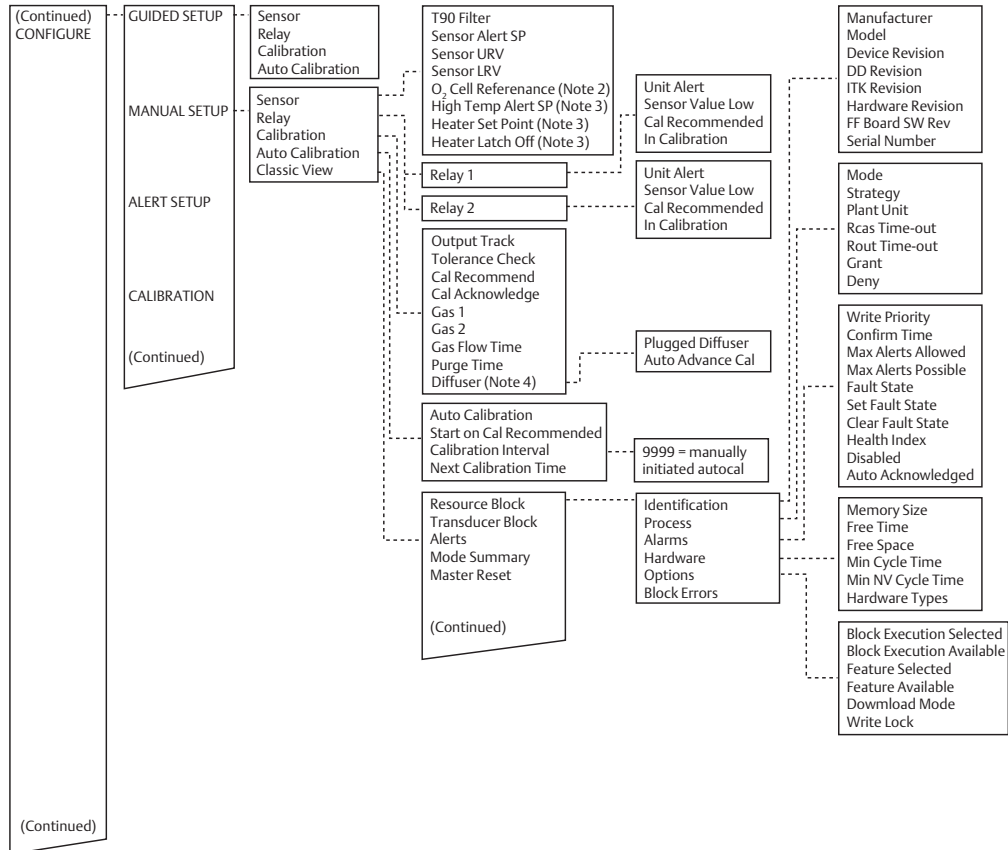

# Foundation Fieldbus Menu Trees

## 375/475 Field Communicator

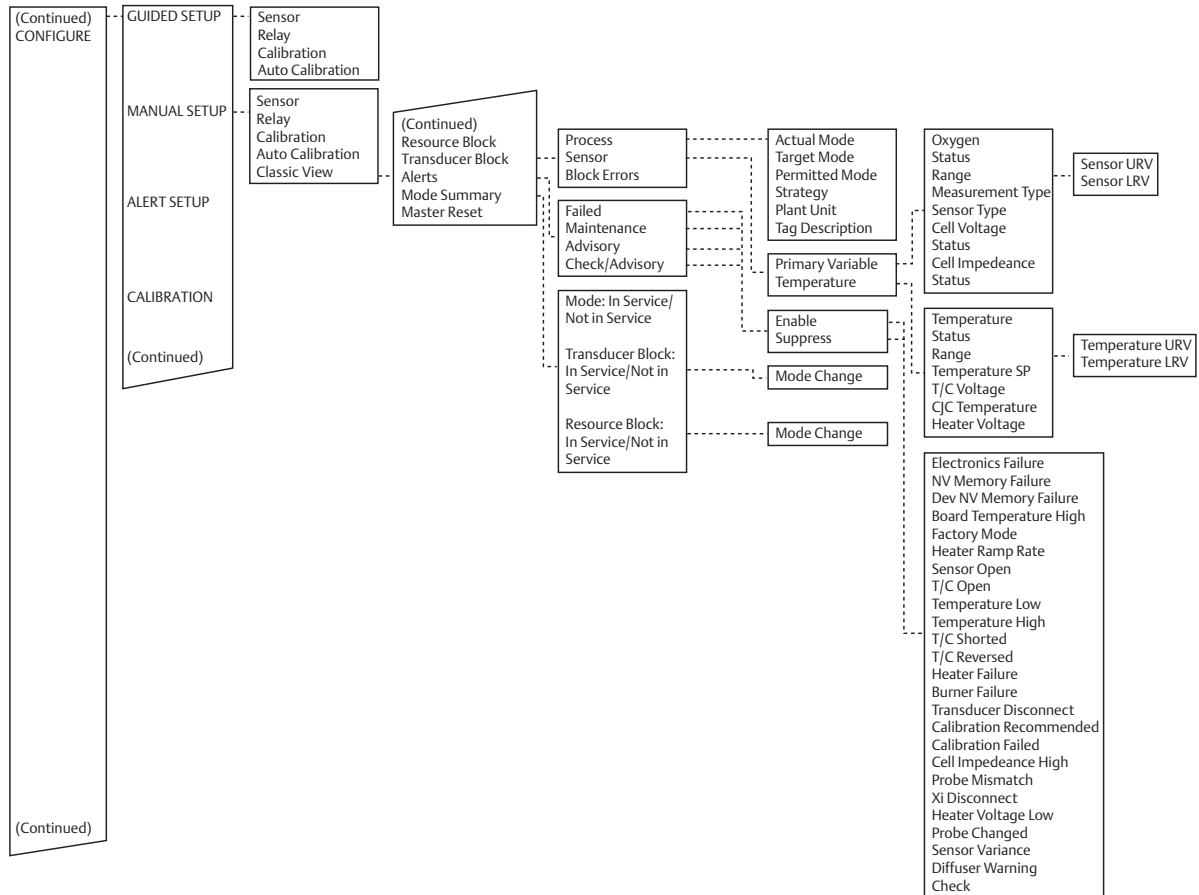



# Foundation Fieldbus Menu Trees

## 375/475 Field Communicator

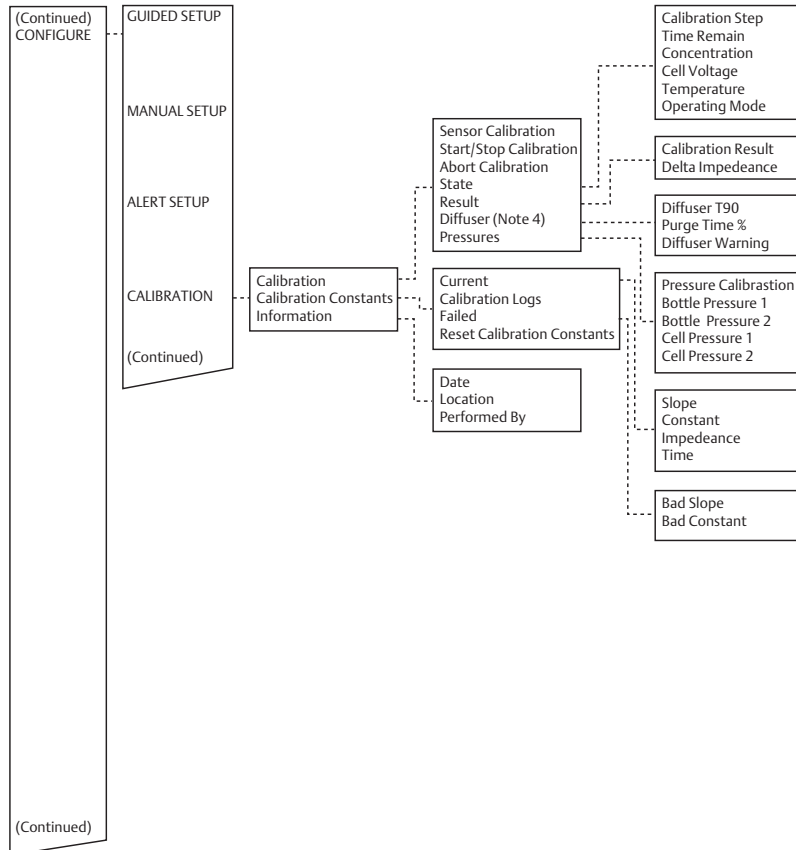

# Foundation Fieldbus Menu Trees

## 375/475 Field Communicator

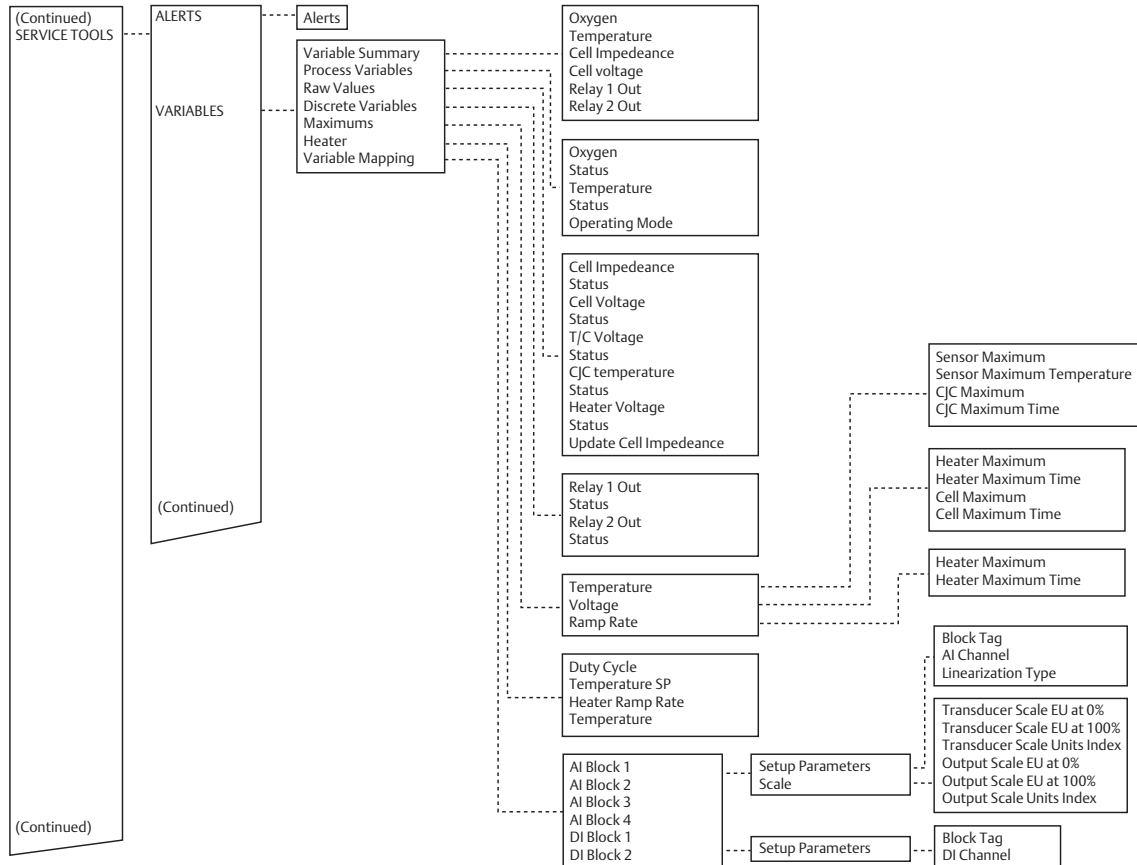

# Foundation Fieldbus Menu Trees

## 375/475 Field Communicator

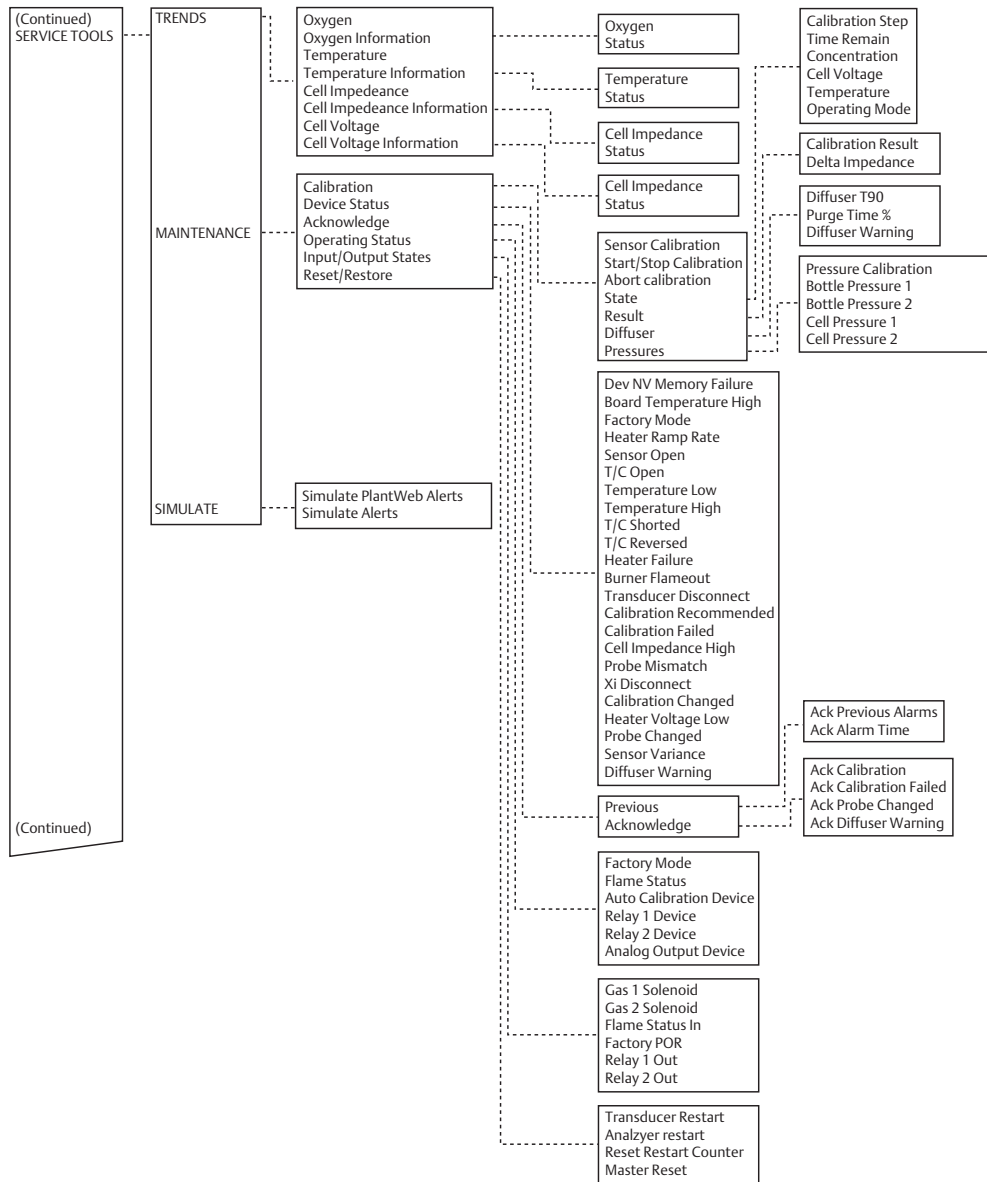

# Foundation Fieldbus Menu Trees

## 375/475 Field Communicator

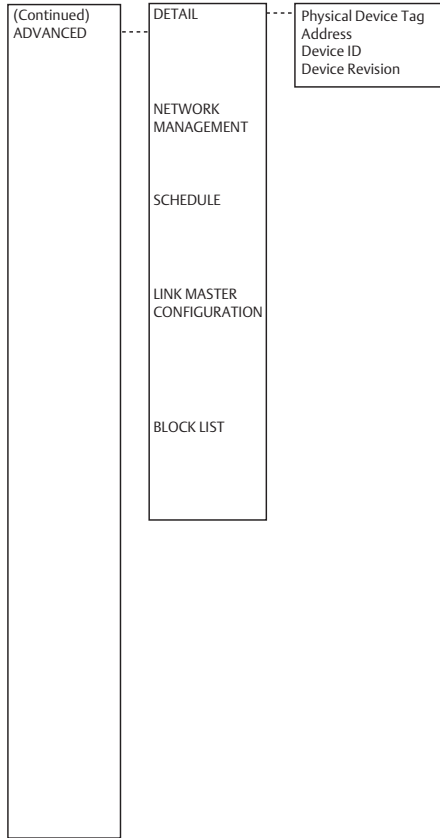

## Safety Data



### IMPORTANT

#### SAFETY INSTRUCTIONS FOR THE WIRING AND INSTALLATION OF THIS APPARATUS

The following safety instructions apply specifically to all EU member states. They should be strictly adhered to in order to assure compliance with the Low Voltage Directive. Non-EU states should also comply with the following unless superseded by local or National Standards.

1. Adequate earth connections should be made to all earthing points, internal and external, where provided.
2. After installation or troubleshooting, all safety covers and safety grounds must be replaced. The integrity of all earth terminals must be maintained at all times.
3. Mains supply cords should comply with the requirements of IEC227 or IEC245.
4. All wiring shall be suitable for use in an ambient temperature of greater than 75°C.
5. All cable glands used should be of such internal dimensions as to provide adequate cable anchorage.
6. To ensure safe operation of this equipment, connection to the mains supply should only be made through a circuit breaker which will disconnect all circuits carrying conductors during a fault situation. The circuit breaker may also include a mechanically operated isolating switch. If not, then another means of disconnecting the equipment from the supply must be provided and clearly marked as such. Circuit breakers or switches must comply with a recognized standard such as IEC947. All wiring must conform with any local standards.
7. Where equipment or covers are marked with the symbol to the right, hazardous voltages are likely to be present beneath. These covers should only be removed when power is removed from the equipment - and then only by trained service personnel.
8. Where equipment or covers are marked with the symbol to the right, there is a danger from hot surfaces beneath. These covers should only be removed by trained service personnel when power is removed from the equipment. Certain surfaces may remain hot to the touch.
9. Where equipment or covers are marked with the symbol to the right, refer to the Operator Manual for instructions.
10. All graphical symbols used in this product are from one or more of the following standards: EN61010-1, IEC417, and ISO3864.
11. Where equipment or labels are marked "Do Not Open While Energized" or similar, there is a danger of ignition in areas where an explosive atmosphere is present. This equipment should only be opened when power is removed and adequate time as specified on the label or in the instruction manual has been allowed for the equipment to cool down and then only by trained service personnel.

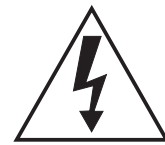

## Return of Material

If factory repair of defective equipment is required, proceed as follows:

1. Secure a return authorization number from a Emerson Process Management Sales Office or representative before returning the equipment. Equipment must be returned with complete identification in accordance with Emerson Process Management instructions or it will not be accepted. In no event will Emerson Process Management be responsible for equipment returned without proper authorization and identification.

### **⚠ CAUTION**

**Observe proper ESD handling and packaging precautions when returning individual circuit boards.**

2. Carefully pack defective unit in a sturdy box with sufficient shock absorbing material to ensure that no additional damage will occur during shipping. When returning individual circuit boards, observe proper ESD precautions.
3. In a cover letter, describe completely:
  - a. The symptoms from which it was determined that the equipment is faulty.
  - b. The environment in which the equipment has been operating (housing, weather, vibration, dust, etc.).
  - c. Site from which equipment was removed.
  - d. Whether warranty or nonwarranty service is requested.
  - e. Complete shipping instructions for return of equipment.
  - f. Reference the return authorization number.
4. Enclose a cover letter and purchase order and ship the defective equipment according to instructions provided in Emerson Process Management Return Authorization, prepaid.

If warranty service is requested, the defective unit will be carefully inspected and tested at the factory. If failure was due to conditions listed in the standard Rosemount Analytical warranty, the defective unit will be repaired or replaced at Emerson Process Management's option, and an operating unit will be returned to the customer in accordance with shipping instructions furnished in the cover letter.

For equipment no longer under warranty, the equipment will be repaired at the factory and returned as directed by the purchase order and shipping instructions.



Rosemount Analytical Inc.

## EC DECLARATION OF CONFORMITY

Form 6

We, Emerson Process Management GmbH & Co. OHG, Industriestraße 1, D-63594 Hasselroth, Germany

Herewith declare under our sole responsibility that the product,

**6888 Oxygen Transmitter, Model 6888A**

manufactured by, Rosemount Analytical Inc., 6565P Davis Industrial Parkway, Solon, Ohio, 44139, USA

is in conformity with the essential requirements and provisions of:

- The EMC Directive (2004/108/EC) including the latest amendments with the application of the harmonized standards:  
**EN 61326:2006**                      *Electrical equipment for measurement, control and laboratory use, EMC requirements, Part 1: General requirements*
- The Low Voltage Directive (2006/95/EC) including the latest amendments with the application of the harmonized standards:  
**EN 61010-1:2001**                      *Safety Requirements for Electrical Equipment for Measurement, Control, and Laboratory Use. Part 1: General Requirements*
- The Pressure Equipment Directive (97/23/EC) including the latest amendments with the application of the harmonized standards:  
*This equipment has been designed and manufactured with sound engineering practices in accordance with Article 3, Paragraph 3 of the PED*

Solon, OH USA  
*(Place of Issue)*

26 January 2012  
*(Date of Issue)*

RAIO EC-39/1  
*(Document No.)*



Andy Kemish, VP Analytical Europe, Analytical Group

**ROSEMOUNT**  
Analytical

# Notes

# Notes

# Notes

### Analytical Headquarters

Emerson Process Management  
Rosemount Analytical  
2400 Barranca Parkway  
Irvine, CA 92606 USA  
T 1.800.854.8257  
F 1.949.474.7250  
[www.rosemountanalytical.com](http://www.rosemountanalytical.com)

### Combustion

**Center of Excellence**  
Emerson Process Management  
Rosemount Analytical  
6565-P Davis Industrial Pkwy  
Solon, OH 44139 USA  
T 1.800.433.6076  
F 1.440.914.1262

### Gas Chromatograph

**Center of Excellence**  
Emerson Process Management  
Rosemount Analytical  
10241 West Little York, Suite 200  
Houston, Texas 77040 USA  
T 1.866.422.3683  
F 1.713.466.8175  
[gc.csc@emerson.com](mailto:gc.csc@emerson.com)

### Flame and Gas Detection

**Center of Excellence**  
Emerson Process Management  
Net Safety Monitoring  
2721 Hopewell Place N.E.  
Calagary, AB T1Y 7J7 Canada  
T 1.403.219.0688  
T 1.866.347.3427  
F 1.440.219.0694  
[safety.csc@emerson.com](mailto:safety.csc@emerson.com)

### Latin America

**Center of Excellence**  
Emerson Process Management  
Rosemount Analytical  
10241 West Little York, Suite 200  
Houston, Texas 77040 USA  
T 1.713.396.8880  
T 1.866.422.3683  
F 1.713.466.8175  
[gc.csc@emerson.com](mailto:gc.csc@emerson.com)

### Europe

**Center of Excellence**  
Emerson Process Management AG  
Blegistrasse 21  
PO Box 1046  
CH 6341 Baar Switzerland  
T 41.41.768.6111  
F 41.41.761.8740

### Middle East and Africa

**Center of Excellence**  
Emerson Process Management  
Emerson Building  
P.O. Box 17033  
Jebel Ali Free Zone  
Dubai, United Arab Emirates  
T 1.971.4.8835235  
F 1.971.4.8835312

### Asia Pacific

**Center of Excellence**  
Emerson Process Management  
Asia Pacific Private LTD.  
Asia Pacific Private Ltd.  
1 Pandan Crescent  
Singapore 128461  
Republic of Singapore  
T 65.6.777.8211  
F 65.6.777.0947



<https://www.facebook.com/EmersonRosemountAnalytical>



<http://www.analyticexpert.com>



<http://www.analyticexpert.com>



<https://twitter.com/RAIhome.com>

Scan the QR code to launch the 6888 Product page for the latest information and other documentation.



Brand product is a core component of the PlantWeb digital plant architecture.

© 2014 Emerson Process Management.  
All rights reserved.

The Emerson logo is a trademark and service mark of Emerson Electric Co. Brand name is a mark of one of the Emerson Process Management family of companies. All other marks are the property of their respective owners.

The contents of this publication are presented for information purposes only, and while effort has been made to ensure their accuracy, they are not to be construed as warranties or guarantees, express or implied, regarding the products or services described herein or their use or applicability. All sales are governed by our terms and conditions, which are available on request. We reserve the right to modify or improve the designs or specifications of our products at any time without notice.