

IntelliVAC Contactor Control Module

Catalog Number Bulletin 1503VC (Series E)



Important User Information

Read this document and the documents listed in the additional resources section about installation, configuration, and operation of this equipment before you install, configure, operate, or maintain this product. Users are required to familiarize themselves with installation and wiring instructions in addition to requirements of all applicable codes, laws, and standards.

Activities including installation, adjustments, putting into service, use, assembly, disassembly, and maintenance are required to be carried out by suitably trained personnel in accordance with applicable code of practice.

If this equipment is used in a manner not specified by the manufacturer, the protection provided by the equipment may be impaired.

In no event will Rockwell Automation, Inc. be responsible or liable for indirect or consequential damages resulting from the use or application of this equipment.

The examples and diagrams in this manual are included solely for illustrative purposes. Because of the many variables and requirements associated with any particular installation, Rockwell Automation, Inc. cannot assume responsibility or liability for actual use based on the examples and diagrams.

No patent liability is assumed by Rockwell Automation, Inc. with respect to use of information, circuits, equipment, or software described in this manual.

Reproduction of the contents of this manual, in whole or in part, without written permission of Rockwell Automation, Inc., is prohibited.

Throughout this manual, when necessary, we use notes to make you aware of safety considerations.



WARNING: Identifies information about practices or circumstances that can cause an explosion in a hazardous environment, which may lead to personal injury or death, property damage, or economic loss.



ATTENTION: Identifies information about practices or circumstances that can lead to personal injury or death, property damage, or economic loss. Attentions help you identify a hazard, avoid a hazard, and recognize the consequence.

IMPORTANT

Identifies information that is critical for successful application and understanding of the product.

Labels may also be on or inside the equipment to provide specific precautions.



SHOCK HAZARD: Labels may be on or inside the equipment, for example, a drive or motor, to alert people that dangerous voltage may be present.



BURN HAZARD: Labels may be on or inside the equipment, for example, a drive or motor, to alert people that surfaces may reach dangerous temperatures.



ARC FLASH HAZARD: Labels may be on or inside the equipment, for example, a motor control center, to alert people to potential Arc Flash. Arc Flash will cause severe injury or death. Wear proper Personal Protective Equipment (PPE). Follow ALL Regulatory requirements for safe work practices and for Personal Protective Equipment (PPE).

	Chapter 1	
Product Description	Introduction.....	7
	Scope	7
	Description.....	7
	IntelliVAC Features	8
	IntelliVAC Versions.....	9
	Specifications	10
	Mounting and Connections.....	10
	Configuration.....	10
	Firmware	10
		Chapter 2
Receiving and Storage	Receiving.....	13
	Storage.....	13
	Chapter 3	
Installation and Wiring	General Precautions.....	15
	Safety and Codes.....	15
	Arrangements.....	15
	Integral to an Allen-Bradley MV Controller	15
	OEM.....	16
	Control Power Fuse	18
	Grounding.....	19
	Connections	19
	Control Power.....	20
	Status Relays	20
	Interface Connections	21
	Wiring Guidelines	22
	Electrically Held Contactors	22
	Control with Solid-State Devices	22
	Two-Wire Control	23
	Three-Wire Control.....	24
	Wiring Guidelines Mechanical Latch Contactors	26
	Mechanical Latch Contactors	27
	Capacitor Trip.....	27
	Motor Jogging Control	28
Undervoltage Protection.....	29	
Time Delay Undervoltage	29	
	Chapter 4	
Setup and Commissioning	IntelliVAC Configuration	31

	Chapter 5	
Monitoring and Troubleshooting	Introduction	33
	Module Status	33
	Contactors Status	34
	Chapter 6	
Spare Parts	Spare Parts List	39
	Optional Equipment	39
	Appendix A	
Contactors Drop-out Time Settings	Typical Settings	41

This manual contains new and updated information.

New and Updated Information

This table contains the changes made to this revision.

Topic	Page
Attention Table added for TDUV feature limitations	30
Added notations to table for DIP Switch explanation Table	32

Notes:

Product Description

Introduction

This document contains information for the Allen-Bradley Bulletin 1503VC IntelliVAC™ control module. The Bulletin 1503VC is used to control the Allen-Bradley Bulletin 1502 vacuum contactors that are a significant component of the Bulletin 1500/1900 CENTERLINE Medium Voltage Motor Controllers offered by Rockwell Automation. IntelliVAC is an efficient and flexible solution for controlling medium voltage vacuum contactors used in motor starter and feeder applications.

An IntelliVAC control module may also be provided as a loose OEM component, for use with a Bulletin 1502 contactor by a third party (OEM).

Scope

This document applies to the Series E version of IntelliVAC. See publication [1503-UM051C-EN-P](#) for information related to the Series A and B designs, and [1503-UM052C-EN-P](#) for information related to Series C and D designs.

Description

An IntelliVAC module may be used to control Bulletin 1502 400 and 800 Amp vacuum contactors. Both electrically held and mechanically latched contactor types can be controlled with IntelliVAC.

Figure 1 - IntelliVAC Contactor Control Module



Figure 2 - IntelliVAC Block Diagram

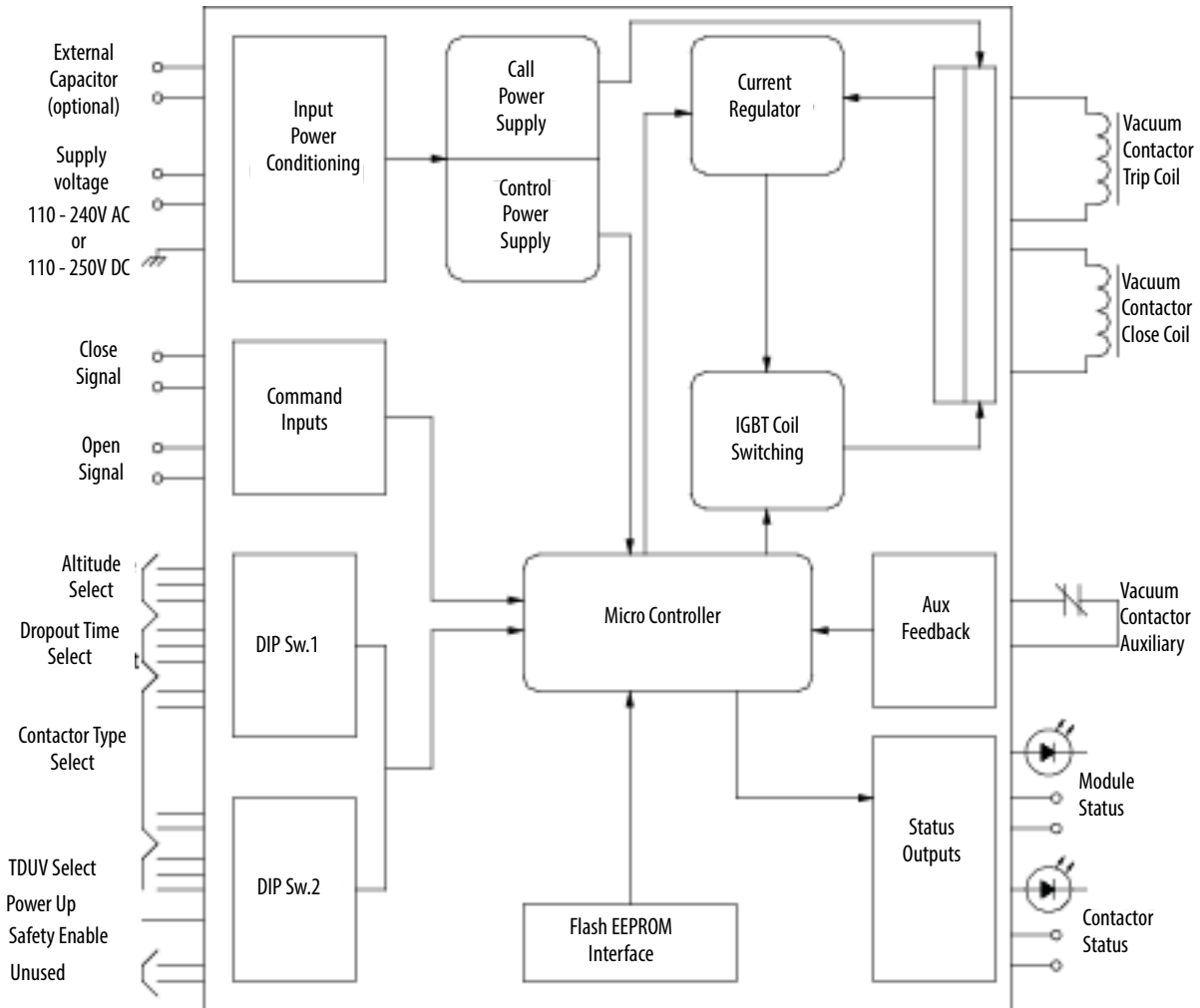

IntelliVAC Features

- A range of supply voltage (110 – 240V AC 50/60 Hz, 110 - 250V DC) allows implementation in multiple applications.
- Consistent vacuum contactor pick-up time (at a given supply voltage) ensures repeatable performance.
- Selectable vacuum contactor drop-out time improves coordination with upstream power fuses.
- Electronic altitude compensation (Bulletin 1502 400 A only) eliminates mechanical compensation required for altitudes above 1000 meters (Bulletin 1502 800 A contactors include a user-friendly mechanical altitude adjustment).

- Power loss ride-through (TDUV) allows the vacuum contactor to remain closed during short power loss (may require an optional external capacitor, dependent on ride-through time).
- Anti-kiss and anti-pumping protection ensure that the vacuum contactor close – open sequence occurs as expected, avoiding rapid reclosure due to faulty control devices.
- Delayed restart protects the vacuum contactor by ensuring that the rated duty cycle is not exceeded.
- Temporary jog function (electrically held contactors only) allows the motor to be positioned for process set-up.

IntelliVAC Versions

See [Chapter 6](#) for part numbers of the various series of modules. The Series Letter is printed on the large label on the right-hand side of the enclosure, beside the part number.

Series A There are two versions of IntelliVAC control. The first type is used to control vacuum contactors that are electrically held, with one electrical coil that is economized electronically. The second is used to control mechanically latched vacuum contactors (no longer available).

Series B There is one version of IntelliVAC, to control electrically held and mechanically latched vacuum contactors (no longer available).

Series C Updated version of the Series B module (no longer available).

Series D Minor functionality (firmware) enhancements, primarily related to definition and handling of Faults and Warnings (no longer available).

Series E Revised hardware to allow connection to the IntelliVAC Plus or IntelliVAC MC. The removal of the mini Din connector for updating firmware (firmware is now updated using the IntelliVAC Plus or IntelliVAC MC boards). New input circuits to reduce thermal output, and decrease sensitivity to leakage current.

See [Chapter 6](#) for catalog numbers for each version of IntelliVAC.

IMPORTANT A Series C, D or E IntelliVAC module can be used to replace a Series A or Series B module. When replacing an older series of IntelliVAC with a newer one, note that the Module and Contactor Status outputs may function differently. See publication [1503-UM051C-EN-P](#) and/or [Chapter 5](#) of this document, and make any necessary changes to the control circuit.

Specifications

Mounting and Connections

The IntelliVAC control modules are mounted using two screws, see [Figure 3 on page 12](#). They are typically located in the low voltage control panel of the medium voltage controller (Bulletin 1500/1900 controllers, in the case of Rockwell Automation).

IntelliVAC is interfaced to the Bulletin 1502 vacuum contactors using a “quick” connector, located at the module, a wire harness and “quick” connector at the contactor. Control power and other control circuit connections are similarly achieved with “quick” connectors.

Configuration

IntelliVAC is easily configured for a wide variety of medium voltage motor and feeder control applications. It is configured using DIP switches, located within the enclosure (front side). See [Chapter 3](#) for information.

Bulletin 1500/1900 controllers are shipped with IntelliVAC preconfigured for the required application. Please see the documents provided with the order.

Firmware

IntelliVAC has firmware stored in flash EEPROM. This may be updated in the field (if necessary). The IntelliVAC board firmware is updated using either the IntelliVAC Plus, or IntelliVAC MC supplementary boards.

The firmware version supplied with the module is displayed on top of the DIP switches, see [Figure 17 on page 31](#)

Series C modules use only version 2.003 application firmware. This firmware is also compatible with the Series A and B modules. Series D modules use only version 3.001 or 3.002 application firmware. This firmware is **not** compatible with any other Series Letter modules. Series E modules use on 4.004 or newer firmware. This firmware is **not** compatible with any other Series Letter modules.

Table 1 - Electrical Ratings

Main Input Voltage (L1 ... L2/N)	AC – 110 ... 240V rms, +10/-15%, 47 ... 63 Hz DC – 110 ... 250V, +10/-15%					
	Description	Contactor Ratings (Amps)	Control Voltage (AC or DC)	AC Rating	DC Rating	Minimum Voltage (V AC, 47 ... 63 Hz)
Main Input Current (L1 ... L2/N)	Inrush Current	400/800	120/240	25 A peak (1/2 cycle)	25 A peak	
	Idle Current (Maximum without contactor coil energized)	400/800	120/240	125 mA	35 mA	
	Hold Current ⁽³⁾ (maximum)	400/800	120/240	300 mA	100 mA	
	Close Current ⁽³⁾ (0.2 sec)	400	120	4.6 A	3.6 A	
			240	3.4 A	3.3 A	
		800	120	11.3 A	4.8 A	
			240	8.9 A	4.5 A	
	Trip Current (latch) ⁽³⁾ (0.2 sec)	400	120	7.0 A	3.7 A	
			240	3.6 A	2.0 A	
		800	120	7.0 A	3.3 A	
			240	4.3 A	1.9 A	
	Minimum IntelliVAC Operational Supply Voltages	Pick-Up	400/800			
Drop-Out		400/800				75
Trip (Mechanical Latch)		400				70
Command Inputs (1) (2)	AC – 70 ... 240V rms DC – 70 ... 250V Maximum on state current for open or close command: 11mA _{AC} @ 276V AC, 60 Hz, T _A = 60 °C 2.4mA _{DC} @ 276V DC, T _A = 60 °C Minimum on state current for open or close command: 2.5mA _{AC} @ 70V AC, 60 Hz, T _A = 60 °C 1.2 mA @ 68V DC, T _A = 60 °C Maximum off state current for open or close command: 1.9 μA @ 60V AC, 60 Hz, T _A = 60 °C 900 μA @ 60V DC, T _A = 60 °C					
Status Output Contacts	AC – 250V rms, 5 A, R load; 2 A (reactive), PF = 0.4 DC – 30V, 5 A, R load; 2 A (reactive), L/R = 7 ms					
Standards and Approvals	CE, cULus, CSA, IEC pending					

(1) T_A = Ambient Temperature

(2) Ensure compatibility of IntelliVAC input ratings with those of circuit components activating these inputs. Consider means of isolating/loading these signals, as required (using interposing relays or load resistors). Consult factory for assistance, if required. The Series C and D IntelliVACs are compatible with most PLC outputs, and have been verified with Rockwell Automation OA type 120V triac outputs. See [Wiring Guidelines on page 22](#).

(3) Includes idle current.

Table 2 -

Table 3 - Mechanical Ratings

Temperature	Operating: 0 ... 60 °C ambient at the control module ⁽¹⁾
	Non-Operating: -40 ... 85 °C
Altitude	-1000 ... 5000 meters
Pollution	Pollution level II (as defined by UL 840 and IEC 60664-1)
Humidity	95% non-condensing
Shock (Operational)	15 g peak, 11 ms
Vibration (operational)	10 ... 57 Hz, 0.015 inch displacement peak to peak 57 ... 150 Hz, 2.5 g acceleration

(1) Ambient temperature is derated at altitudes above 1000 meters (3300 feet). See [Chapter 1](#).

Table 4 - Altitude Derating

Altitude	Maximum Operation Ambient at the control module (°C) ⁽¹⁾
-1000 ... 0	60
1 ... 1000	60
1001 ... 2000	58
2001 ... 3000	56
3001 ... 4000	54
4001 ... 5000	52

(1) Derate by 2°C / 1000 m for high altitude operation.

Figure 3 - Mechanical Dimensions

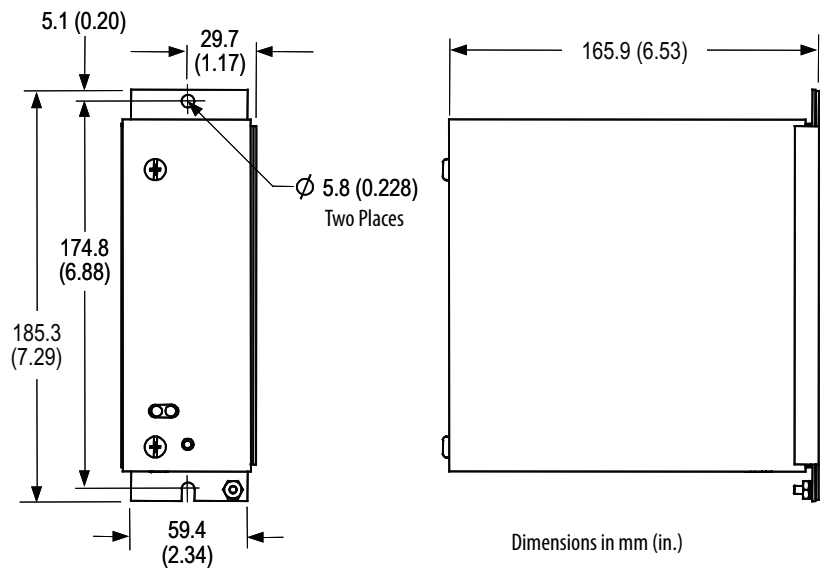

Receiving and Storage

Receiving

Upon receiving the controller, remove the packing and check for damage that may have occurred during shipping. Report any damage immediately to the claims office of the carrier.

IMPORTANT If the IntelliVAC module is an integral component of a complete MV controller (Bulletin 1500/1900), special receiving and handling instructions will apply. For details, see the service manual provided with the equipment.

Storage

Consider these important storage requirements if you are not installing your controller immediately after receiving it.

- Store the controller in a clean, dry, dust-free environment.
- Storage temperature should be maintained between -40... 85°C (-40... 185°F).
- Relative humidity must not exceed 95%, non-condensing.

Notes:

Installation and Wiring

General Precautions

In addition to the precautions listed throughout this manual, the following statements, which are general to the system, must be read and understood.



ATTENTION: The controller contains ESD (electrostatic discharge) sensitive parts and assemblies. Static control precautions are required when installing, testing, servicing, or repairing the assembly. Component damage may result if ESD control procedures are not followed. If you are not familiar with static control procedures, see applicable ESD protection handbooks.



ATTENTION: An incorrectly applied or installed controller can damage components or reduce product life. Wiring or application errors, such as incorrect or inadequate AC supply, or excessive ambient temperatures, may result in malfunction of the system.



ATTENTION: Only personnel familiar with the controller and associated machinery should plan or implement the installation, start-up, and subsequent maintenance of the system. Failure to do this may result in personal injury and/or equipment damage.

Safety and Codes



ATTENTION: The Canadian Electrical Code (CEC), National Electrical Code (NEC), or other local codes outline provisions for safely installing electrical equipment. Installation **MUST** comply with specifications regarding wire type, conductor sizes, branch circuit protection, interlocking and disconnect devices. Failure to do so may result in personal injury and/or equipment damage.

Arrangements

The IntelliVAC is offered in two arrangements, Integral (part of an Allen-Bradley Bulletin 1500/1900 MV controller) or as an OEM component.

Integral to an Allen-Bradley MV Controller

The IntelliVAC is available as a primary component of an Allen-Bradley Bulletin 1500/1900 MV controller, see [Figure 4 on page 16](#).

Figure 4 - Typical IntelliVAC Installation within a Bulletin 1500/1900 MV Controller (Shown with optional external capacitor)



OEM

The IntelliVAC can be ordered as an OEM component. This allows the OEM to mount the components in a configuration most suitable to the control equipment layout. Care must be exercised to ensure the IntelliVAC has adequate ventilation provided around it. See [Figure 5 on page 17](#) for mounting the IntelliVAC. It is recommended that a minimum of 38.1 mm (1.5 in.) of free air space be provided between the IntelliVAC and any solid barrier above or below. As well, 6.4mm (0.25 in) should be left between adjacent modules.

The OEM is responsible for controller fusing, motor overload protection, control devices (for example Start/Stop push buttons), and wiring between the IntelliVAC and 1502 vacuum contactor (using optional wire harness). Wiring and mounting for optional items, such as TDUV Capacitor, are also the OEM's responsibility. See [Figure 6 on page 18](#) for basic connections.

Figure 5 - Typical Mounting Configurations

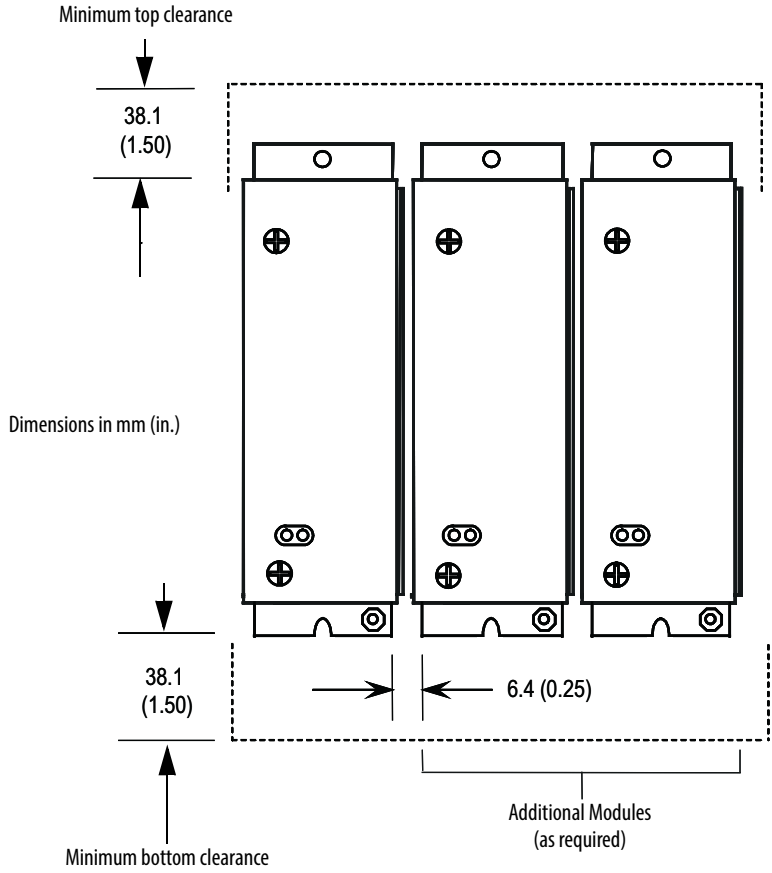

IMPORTANT Adjacent IntelliVAC modules may be mounted with a minimum separation of 6.4 mm (0.25 in.).

Figure 6 - IntelliVAC Typical Schematic (Electrically Held Vacuum Contactor)

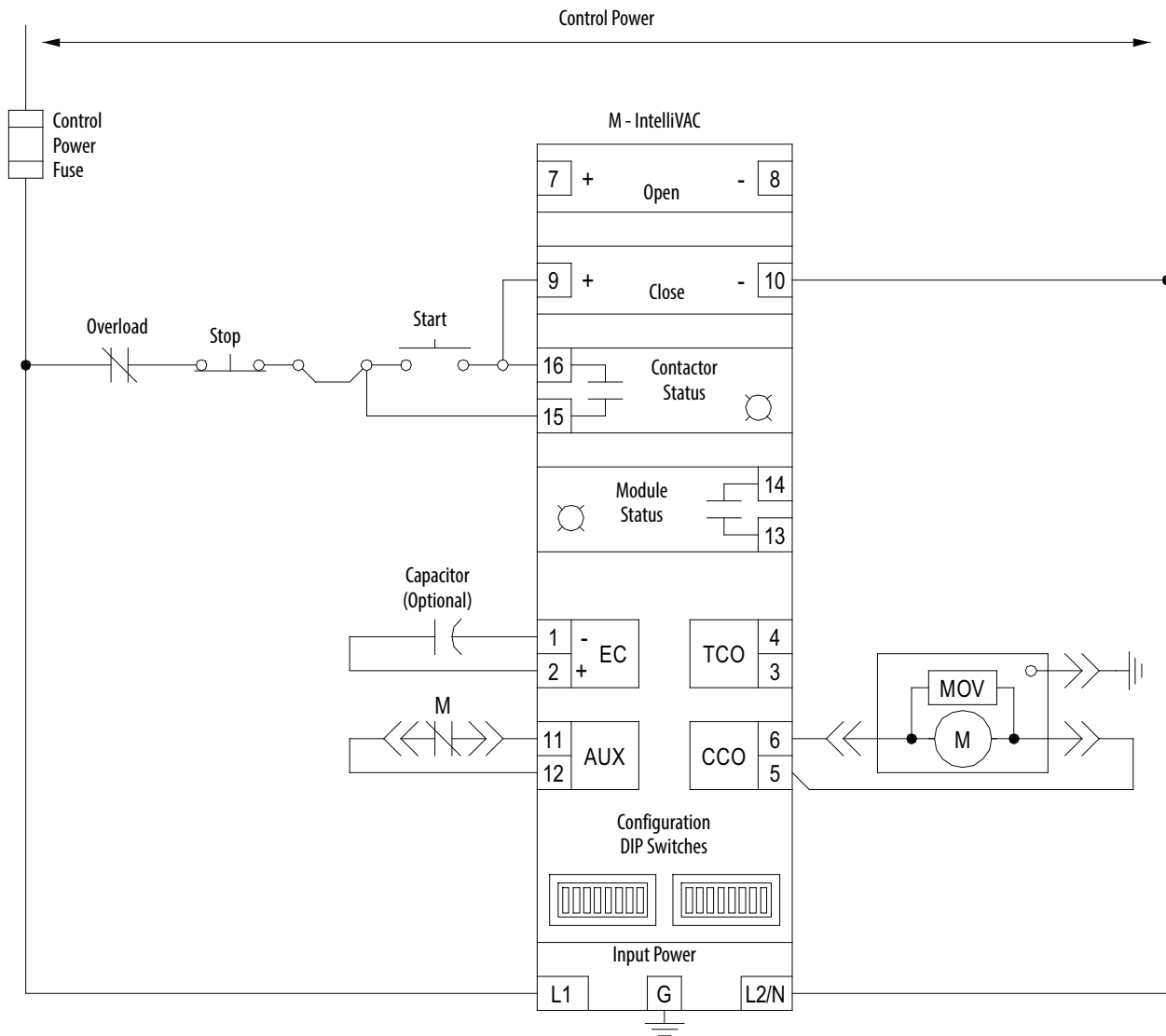

Control Power Fuse

The IntelliVAC module requires external fuse protection to coordinate with the power supply and contactor. The fuse ratings shown in [Table 5 on page 19](#) allow the passage of inrush currents expected when the contactor is closed, or from recommended external capacitors for the TDUV option. They will also protect the contactor coils in the event of a module malfunction.

The recommended fuses have been tested to ensure reliable protection of the module. If the supply voltage is DC, the module must be used with an external fuse that is approved for and rated to interrupt the DC voltage supply. The types listed are Ferraz-Shawmut Midget Fuses (1-1/2 in.X 13/32 in.). The TRM is a time-delay type, rated 250V AC. The ATM is a fast-acting type, rated 500V DC.

Table 5 - IntelliVAC Fuse Protection

Rated Supply Voltage	Contactor Type ⁽¹⁾	Recommended Fuse	
		(minimum)	(maximum)
110/120V AC	400A EH	TRM 2	TRM 3.2
	800A EH	TRM 2	TRM 6.25
	400/800A ML	TRM 2	TRM 3.2
220/240V AC	400A EH	TRM 2	TRM 6.25
	800A EH	TRM 2	TRM 6.25
	400/800A ML	TRM 2	TRM 6.25
125V DC	400A EH/ML	ATM 3	ATM 3
	800A EH/ML	ATM 5	ATM 6
250V DC	400A EH/ML	ATM 3	ATM 5
	800A EH/ML	ATM 5	ATM 6

(1) Electrically Held vacuum contactor (EH), Mechanical Latch vacuum contactor (ML).

IMPORTANT If external capacitors are connected, or more than one IntelliVAC module is protected by a common control fuse, the maximum recommended fuse should be used to prevent fuse opening due to increased inrush current when control power is applied.

Grounding

The IntelliVAC module must be connected to a common ground terminal (PE) on the controller panel. The ground terminal is located on the bottom of module enclosure, see [Figure 7 on page 20](#).



ATTENTION: It is important that IntelliVAC is properly grounded using the ground connection provided. Failure to do so may result in damage to equipment or personal injury.

Connections

There are three green connectors on the IntelliVAC module for connections to the control circuitry. Connector plugs are provided with the module. If replacement plugs are required, see [Chapter 6, Spare Parts](#).

Control Power

The IntelliVAC can accept either AC or DC control power. See [Table 1 on page 11](#) for acceptable input power and control signal ratings.

Control power is applied to the module with a two-pole connector located at the bottom rear portion of the module. See [Figure 7](#) for connections. The ‘L1’ connection is intended to be the ‘Hot’ or ‘+’ side of the control power, and the ‘L2/N’ connection is intended to be the ‘Neutral’, ‘Return’, or ‘-’ side of the control power.

Status Relays

Status relay connections are accessed with a four-pole connector located at the bottom front portion of the module. See [Figure 7](#) for connections. There are two status relays, each with one normally-open contact:

- Module Status: Terminals 13 and 14
- Contactor Status: Terminals 15 and 16

See [Monitoring and Troubleshooting on page 33](#) for a description of operation for the relays.

See [Table 1 on page 11](#) for electrical ratings of the status relays.

Figure 7 - Bottom side connections

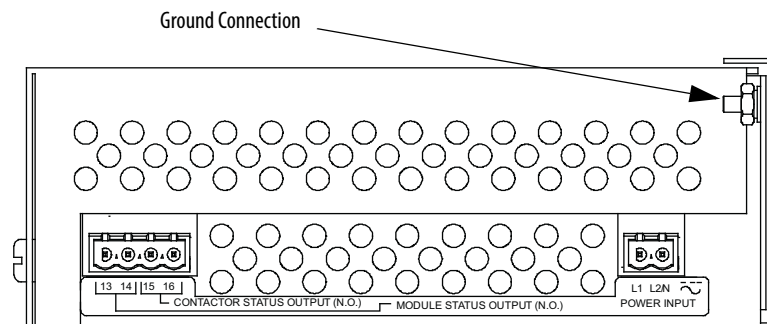

Interface Connections

All other control interface connections are made at a twelve-pole connector located on the top of the module. See [Figure 8 on page 21](#) and [Table 6 on page 21](#) for connections, and [page 11](#) for electrical ratings.

See [Wiring Guidelines on page 22](#) for guidance in making connections to the control circuit.

Figure 8 - Top side connections

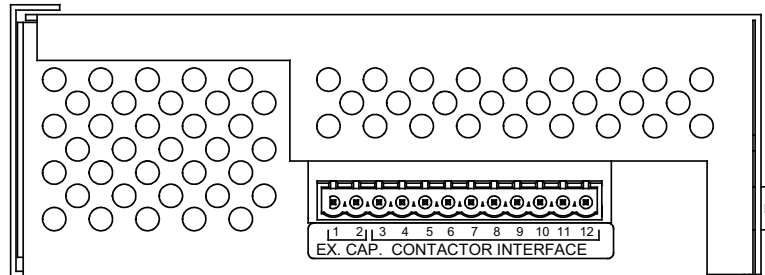

Table 6 - Terminal Assignments for IntelliVAC Interface Connections

See [page 11](#) for electrical ratings.

Terminal Number	Terminal Designation	Description
1	External capacitor (negative) ⁽¹⁾	Power connection for TDUV or capacitor trip options only
2	External capacitor (positive) ⁽¹⁾	
3	Latch trip coil (common) ⁽¹⁾	Output for mechanical latch contactor trip coil
4	Latch trip coil ⁽¹⁾	
5	Close coil (common)	Output to close coil of electrically held & mechanical latch contactors
6	Close coil	
7	Open / Jog command ^{(1) (2) (3)}	Input to open a mechanical latch contactor or jog an electrically held contactor (mutually exclusive)
8	Open / Jog command (common) ^{(1) (2) (3)}	
9	Close command ⁽²⁾	Input to initiate the closure of electrically held and mechanical latch contactors
10	Close command (common) ⁽²⁾	
11	Contactor auxiliary contact ⁽²⁾	Input to indicate the state of the contactor (typically wired to a normally closed auxiliary contact)
12	Contactor auxiliary contact ⁽²⁾	

(1) No connection required if option is not used.

(2) Ensure compatibility of IntelliVAC input ratings with those of circuit components activating these inputs. Consider means of isolating/loading these signals, as required (using interposing relays or load resistors). Consult factory for assistance, if required. The Series C and D IntelliVACs are compatible with most PLC outputs, and have been verified with Rockwell Automation OA type 120V triac outputs. See [Wiring Guidelines on page 22](#).

(3) For electrically held contactor, this command will energize the close coil output (CCO).
For mechanically held contactor, this command will energize the trip coil output (TCO).

Wiring Guidelines

Electrically Held Contactors

The IntelliVAC can be applied with two-wire or three-wire control circuits. The control system used will determine the configuration of the input wiring. Consider the following input and output for the type of control used:

- Terminals 9 and 10 – Close Contactor
- Terminals 15 and 16 – Contactor Status

In either case, the CLOSE input must receive a maintained voltage high to keep the contactor closed.

IMPORTANT

1. When used with electrically held contactors, the IntelliVAC allows close commands every six seconds. This is to ensure the rated contactor duty cycle is not exceeded.
 2. If IntelliVAC powers up configured for an electrically held contactor, and the vacuum contactor is detected as being closed, the module will not respond to a close command until the vacuum contactor auxiliary contact input is in the correct (closed) state and module power is removed and reapplied. See [Chapter 5](#).
 3. In general, a Close command should only be applied 4 seconds after energizing IntelliVAC.
-



ATTENTION: For Emergency Stop applications requiring removal of power, a contact should be placed in the “L1” control power rung to the IntelliVAC. If the TDUV feature is used, the contactor will not open until the programmed TDUV time has expired.

Control with Solid-State Devices

When control devices that employ electronic or suppressed output circuits are used in the rung(s) that control the inputs to the IntelliVAC, alternate arrangements may be required. Devices employing transistor or triac output circuits have finite impedance and allow a leakage current to flow in the blocking or off state. Some PLC and I/O modules with relay outputs have R-C snubber circuits across the contact to suppress voltage transients generated during contact opening. The impedance of these snubber circuits also allows leakage current to flow when the contacts are open. The IntelliVAC input circuits have been designed such that typical output leakage currents should not create unintended operation of the contactor. The vast majority of control devices can be directly connected to the IntelliVAC without any inappropriate operation occurring.



ATTENTION: For Emergency Stop applications requiring removal of power, a contact should be placed in the “L1” control power rung to the IntelliVAC. If the TDUV feature is used, the contactor will not open until the programmed TDUV time has expired.

Figure 10 - Two-Wire Control

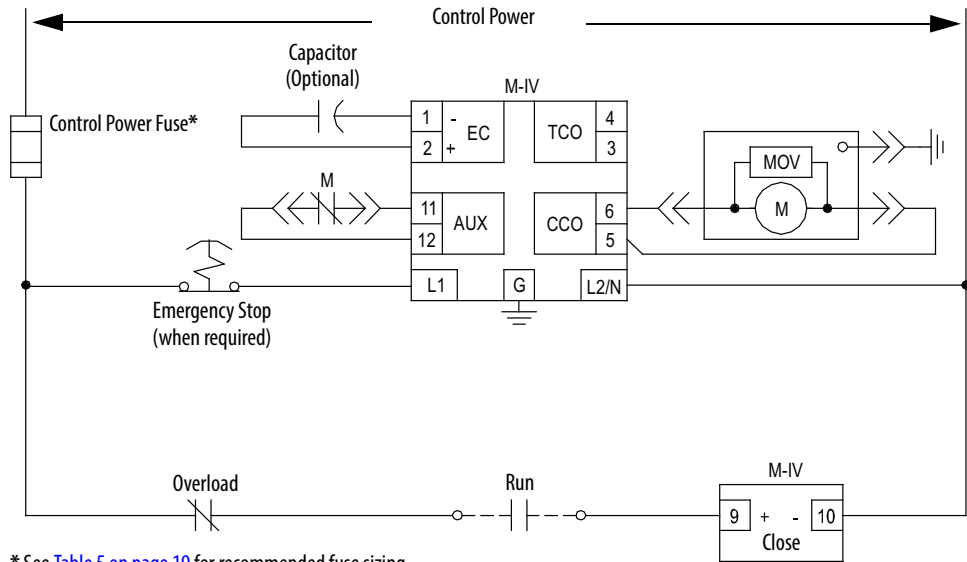

* See [Table 5 on page 19](#) for recommended fuse sizing.

Three-Wire Control

If using three-wire control, the CLOSE contactor input is maintained high using two contacts. Momentarily opening this input will cause the IntelliVAC to open the contactor. Momentarily closing the START contact will provide a CLOSE command to IntelliVAC (given that all permissives are satisfied).

In this configuration, the STATUS output acts as a seal-in contact. If a fault occurs, in addition to cycling control power over to the IntelliVAC module, the CLOSE command must be removed for a minimum of 4 seconds before being reapplied. See [Figure 11 on page 25](#).



ATTENTION: For Emergency Stop applications requiring removal of power, a contact should be placed in the “L1” control power rung to the IntelliVAC. If the TDUV feature is used, the contactor will not open until the programmed TDUV time has expired.

Figure 11 - Three-Wire Control

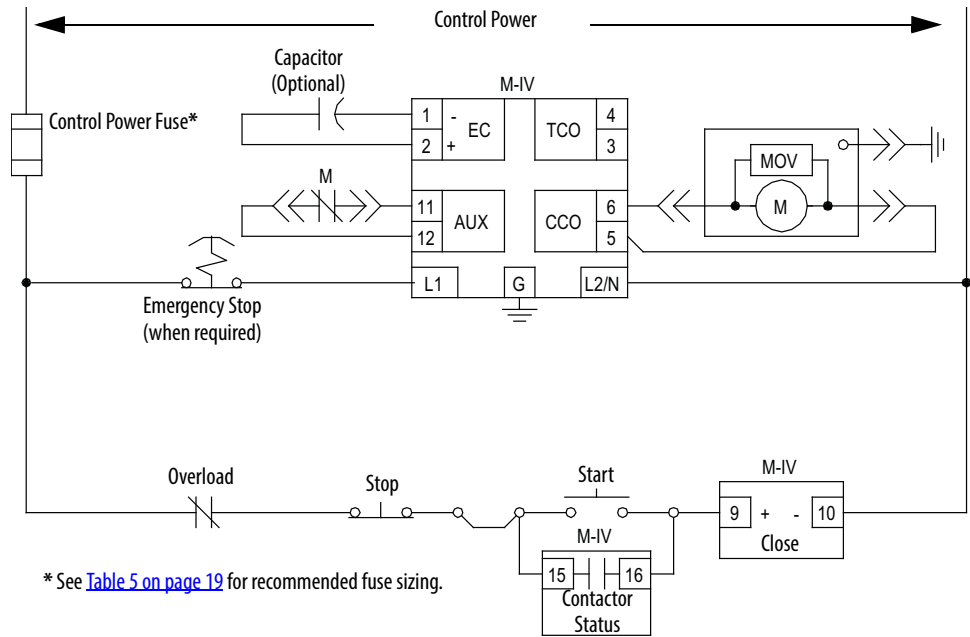
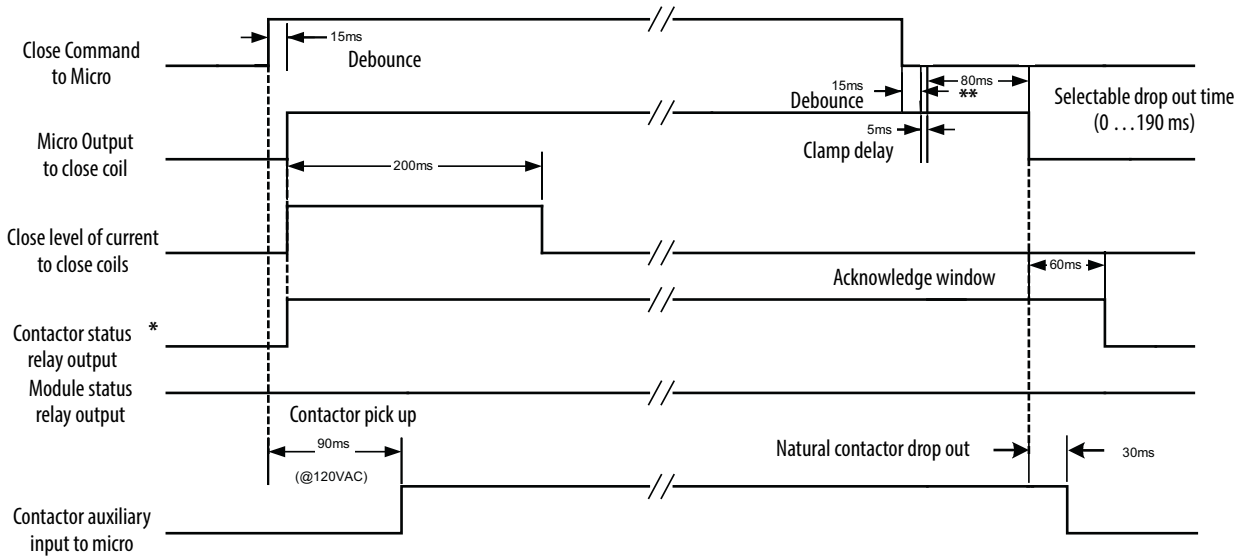

Figure 12 - Timing Diagram 400A (Electrically Held) Contactor for IntelliVAC Control with three-wire Control



* Contact status relay closes on request to close. It will open if the contactor does not close within 200 ms and module will fault (opening module status relay).

**For this example, the 130 ms drop-out time has been selected. The drop-out time is 50 ms. The micro controller delay is 130-50=80 ms.

Wiring Guidelines Mechanical Latch Contactors

IntelliVAC control can be used for mechanical latch contactors. A momentary control signal is required to close the contactor, and a second momentary control signal is required to open the contactor. The momentary open/close commands must be at least 50 ms in duration.

See [Figure 13 on page 26](#) for a typical mechanical latch control scheme.

IMPORTANT A mechanical latch contactor may be closed when power is applied to the IntelliVAC control module.

IMPORTANT It is permissible to apply an open command to the IntelliVAC module as power is reapplied.

Figure 13 - Mechanical Latch Contactor Control

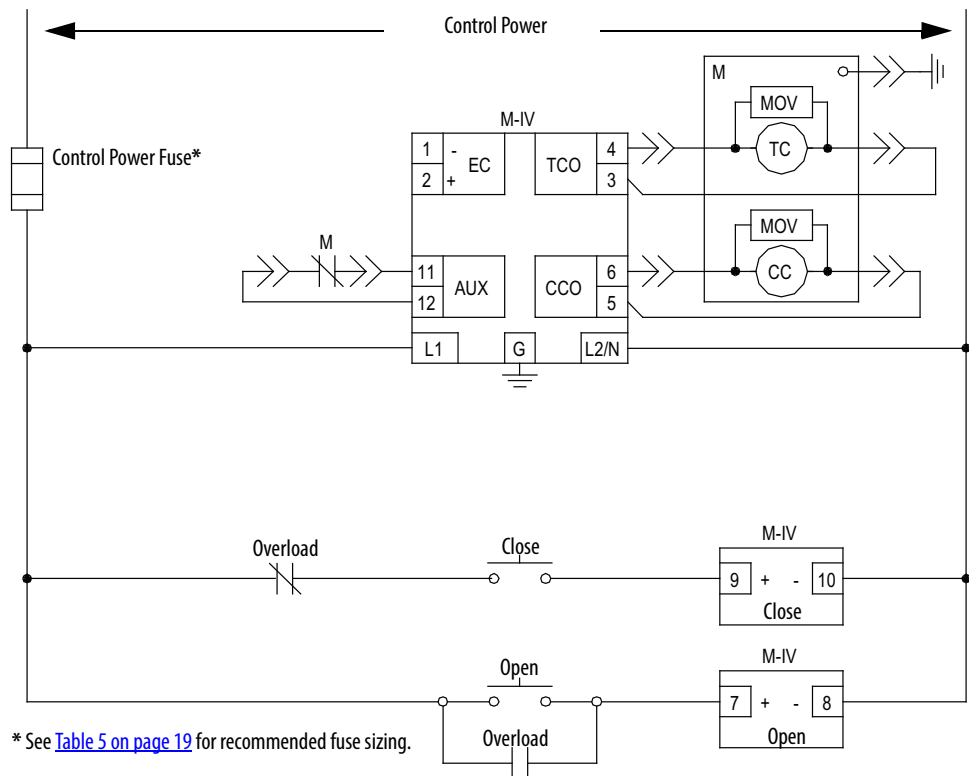

Mechanical Latch Contactors Capacitor Trip

The IntelliVAC can be configured to provide capacitor trip functionality with mechanical latch contactors. A capacitor must be connected to the IntelliVAC (terminals #1 and #2) to provide this capability. The capacitor provides control power for the IntelliVAC and stored energy to trip the contactor. Maximum recommended capacitor size is 1650 μF for 120V control or 330 μF for 240V control. Use of larger capacitors is not recommended.

The IntelliVAC must receive an 'OPEN' command within a few seconds of losing AC control power. This time limit depends on voltage and capacitor size as shown in [Table 7](#). If the elapsed time exceeds this limit, the contactor cannot be tripped by IntelliVAC. In this case, the contactor can be tripped by pressing the release button on the door in front of the contactor.

A separate voltage source is required to provide the 'OPEN' command. This can be taken from the external capacitor as shown in [Figure 14 on page 28](#).

Table 7 - Mechanical Latch Contactor – Capacitor Trip Times (after loss of control power)

Contactor Rating	Nominal Voltage (Vac)	Actual V_{input} (Vac)	Ext. Capacitor (μF)	Max. time for trip (sec)
400 Amp	120	120	1650	3.5
		110		2.7
		100		1.7
	240	140	330	7.5
		200		4.7

IMPORTANT Minimum capacitor voltage ratings:

- 120V applications – 200V DC (250V DC preferred)
- 240V applications – 400V DC (450V DC preferred)

Figure 14 - Mechanical Latch Contactor with Capacitor Trip Option

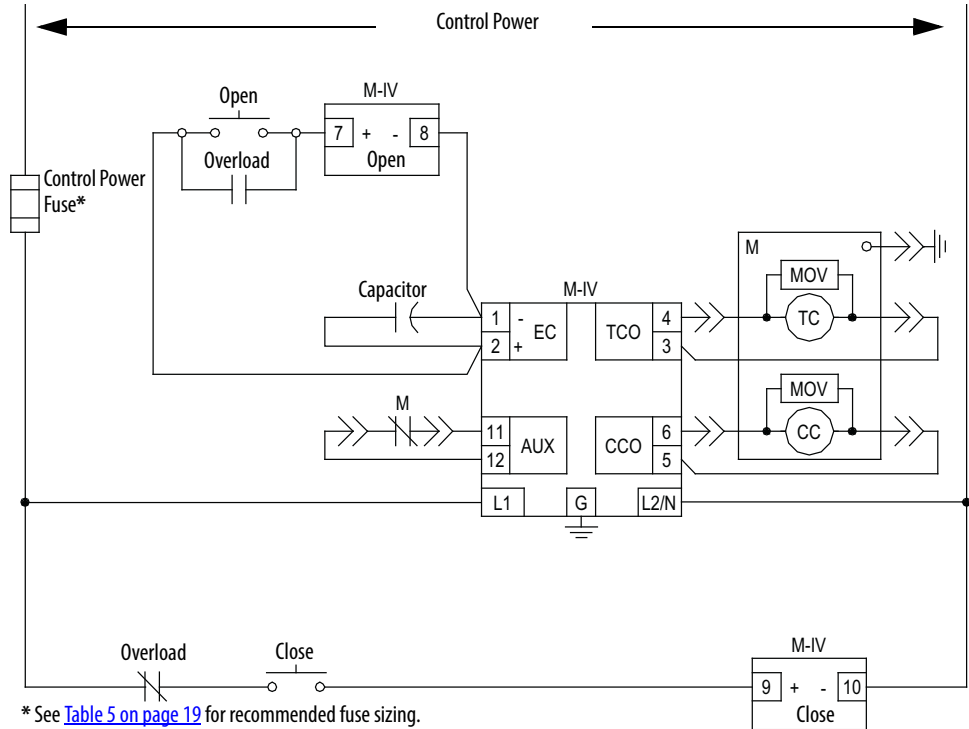

Motor Jogging Control

IMPORTANT Jog functionality can work with electrically held contactor only.

When used with electrically held contactors, the IntelliVAC allows close commands every six seconds. This is to ensure the rated contactor duty cycle of 600 operations per hour is not exceeded.

For motor jogging operations, the second control input, or OPEN command, will close the contactor for as long as the input is present, and open the contactor when the input is removed (see Figure 15 on page 29). This method will bypass the standard six second motor restart delay for jogging purposes only. Operations will be limited to two starts every twelve seconds.



ATTENTION: If the TDUV feature is used, the contactor will not open until the programmed TDUV time has expired. Therefore, applications requiring an immediate removal of power during emergency stop conditions are not compatible with the TDUV feature.

Figure 15 - Motor Jogging Control

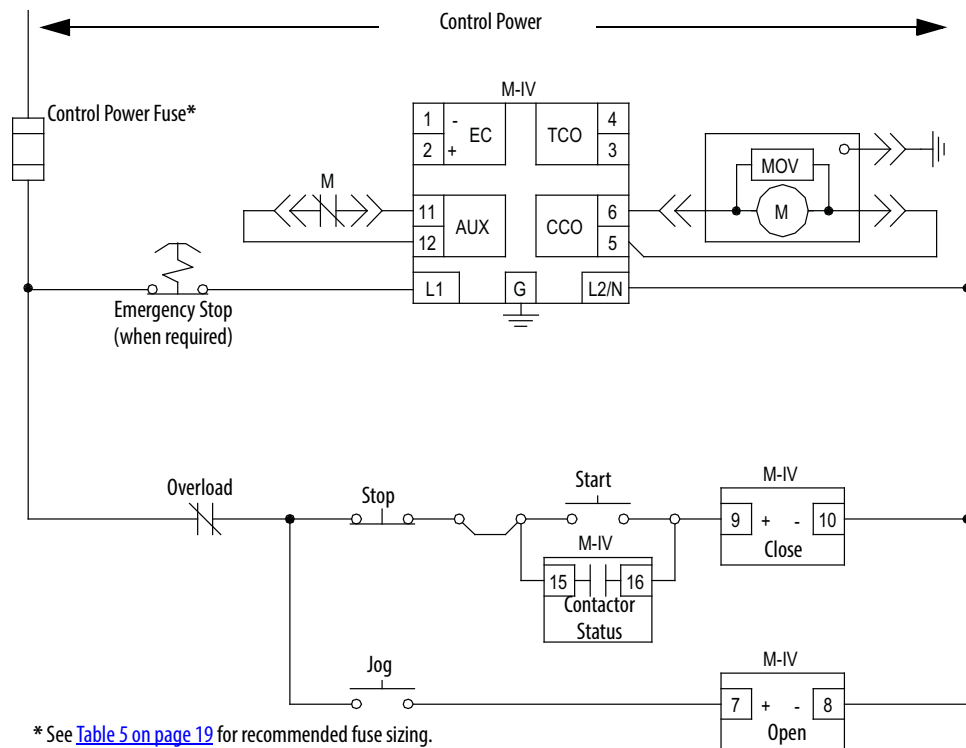

Undervoltage Protection

The IntelliVAC controller protects the contactor from control voltage dips and loss of power. It provides undervoltage release and prevents attempts to close the contactor when insufficient power is available to guarantee reliable closing of the contacts. The undervoltage protection will be initiated under the following conditions, regardless of nominal control voltage:

1. If the supply voltage drops below 90V (AC or DC) during the first 200 ms after a Close command is received. This applies to electrically held and mechanical latch contactors.
2. If the supply voltage drops below 72V (AC or DC) after the 200 ms close sequence (electrically held contactors only).

Time Delay Undervoltage

The IntelliVAC can be configured to provide time delay undervoltage (TDUV) protection. The feature is available to keep electrically held contactors closed during a voltage dip or brief power loss. This option may require the addition of a capacitor (see below). See [Chapter 6](#) for typical capacitor sizing. The capacitor is connected to terminals 1 (-) and 2 (+) of the IntelliVAC, see [Figure 16](#).



ATTENTION: If the TDUV feature is used, the contactor will not open until the programmed TDUV time has expired. Therefore, applications requiring an immediate removal of power during emergency stop conditions are not compatible with the TDUV feature.

[Table on page 32](#) of the “Setup and Commissioning” chapter has the dip switch settings to provide TDUV from 0.2 ...2 seconds. IntelliVAC can provide TDUV protection without the use of an external capacitor, see [Table 8 on page 30](#).



ATTENTION: The TDUV feature has limitations, if used for an input contactor on a PF7000 drive with the Safe Torque Off option. See [Table on page 32](#).

Table 8 - Maximum TDUV Time (without Capacitor)

Control Voltage	Max. TDUV Time (s)	
	400 A	800A
110/120V	0.2	0.2
220/240V	1.0	1.0

If the undervoltage condition persists beyond the set delay time, the contactor will be opened and an undervoltage fault or warning condition will occur, see [Chapter 5](#).

Figure 16 - TDUV Control Circuit

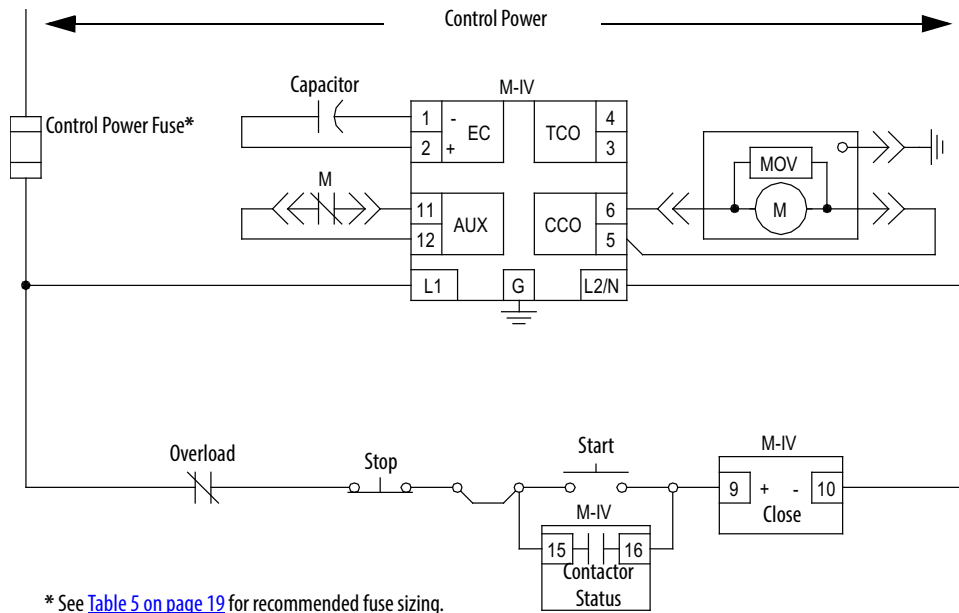

Setup and Commissioning

IntelliVAC Configuration

The IntelliVAC module is configured for a specific application by setting DIP switches. They are accessed by loosening the two screws on the front of the unit, and removing the cover by sliding it forward. The switches are found on the front edge of the IntelliVAC circuit board, see [Figure 17](#). There are 16 switches, with number 1 being at the top closest to the circuit board part number label, see [Table on page 32](#)).



SHOCK HAZARD: Hazardous voltage is present inside the module which may cause personal injury or death. Remove all sources of power from the module and discharge any connected capacitors before removing the cover.

IMPORTANT

Remove power from the module before removing the cover and before changing the DIP switch settings. The new DIP switch settings are recognized only on power-up.

Figure 17 - DIP Switch and Connector Locations

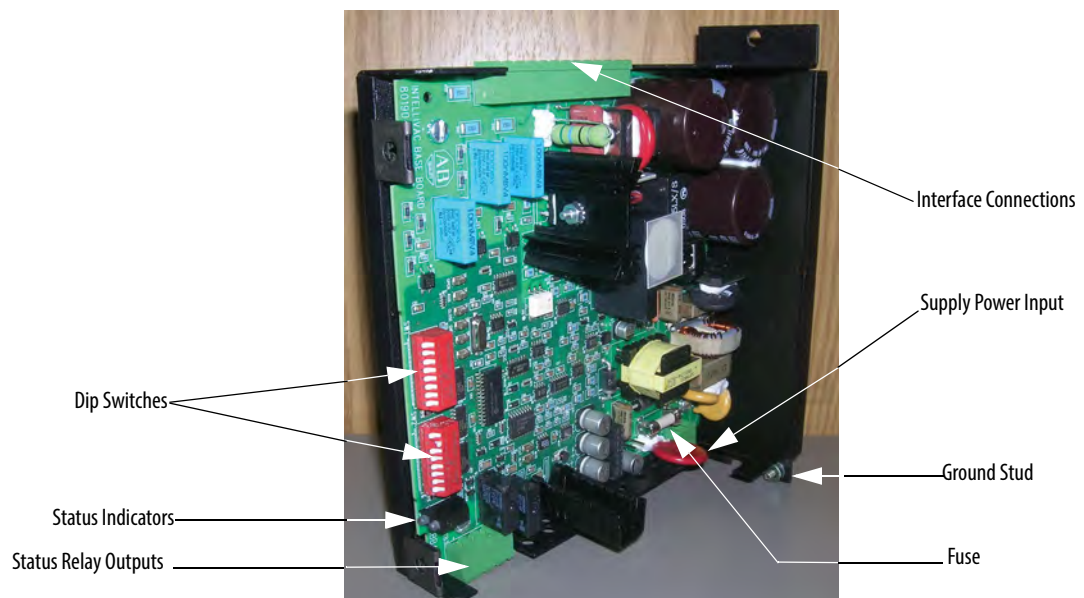

A 1503WC-BMC IntelliVAC unit shipped separately from the factory will have a default configuration per [Table 9 on page 32](#).

Table 9 - DIP Switch Factory Default Settings

Description	DIP switch SW1								DIP switch SW1							
	1	2	3	4	5	6	7	8	1	2	3	4	5	6	7	8
Altitude: 0 ... 1000 m	0	0	1													
Drop-out time: 130 msec				0	1	1										
Contactor config.: 400 A EH							0	0		0	1					
TDUV config.: No TDUV											0					
Ext. cap TDUV time: 0.2 sec												0	0			
Power-Up Safety: Enable															0	

IntelliVAC units shipped in a complete MV controller (Bulletin 1500/1900) are configured for the installed application (contactor type). The user must verify the settings before energizing the equipment. [Table](#) defines the switch settings.

IntelliVAC DIP Switch Explanation

UP = 1 Down = 0	DIP switch SW1								DIP Switch SW 2								
	1	2	3	4	5	6	7	8	1	2	3	4	5	6	7	8	
Altitude⁽¹⁾																	Power-up Safety
-1000 ... 0	0	0	0														0 Enable
1 ... 1000	0	0	1														1 Disable
1001 ... 2000	0	1	0														
2001 ... 3000	0	1	1														4 5 Ext. cap. TDUV time⁽³⁾
3001 ... 4000	1	0	0														0 0 No ext. capacitor ⁽⁴⁾
4001 ... 5000	1	0	1														0 1 1.0 Seconds
Not defined	1	1	0														1 0 1.5 Seconds
Not defined	1	1	1														1 1 2.0 Seconds
Drop out time⁽²⁾				4	5	6						3	TDUV configuration⁽³⁾				
50 msec				0	0	0						0	No TDUV				
75 msec				0	0	1						1	TDUV Enabled				
100 msec				0	1	0											
130 msec				0	1	1	7	8	1	2	Contactor Configuration						
150 msec				1	0	0	0	0	0	0	400A Mechanical Latch		Note: Remaining combinations reserved for future use.				
175 msec				1	0	1	0	0	0	1	400A Electrical Latch						
200 msec				1	1	0	0	0	1	0	800A Mechanical Latch						
240 msec				1	1	1	0	0	1	1	800A Electrical Latch						

- (1) The altitude compensation by DIP switch settings applies to Series E or higher 400 amp vacuum contactors only. All 800 amp contactors are adapted for altitude by altering the mechanical return springs, see [Contactor Manual 1502-UM050](#). 800 amp contactors are to be set for 1 ... 1000m (001 DIP setting).
- (2) By-pass contactors in MV SMC applications must be set for 50 ms drop-out time. See [Chapter A](#) for typical drop-out time settings used when power fuses are provided by Rockwell Automation.
- (3) Input Contactors in MV PF7000 applications with the Safe Torque Off Option (-24STO, -24STORK) must not use the TDUV feature set to more than 0.2 sec.
- (4) The lowest TDUV ride through time (see Table 7)

Monitoring and Troubleshooting

Introduction

The IntelliVAC module has two light emitting diodes (LEDs) and relay outputs to indicate the status of the contactor and the IntelliVAC module. The Status Indicator are visible on the front of the module and the relay outputs are accessed on the terminal block of the bottom front of the module.

Figure 18 - IntelliVAC Status Indicators

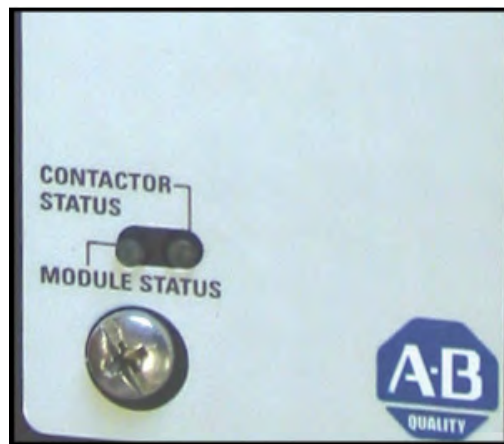

IMPORTANT This user manual contains information for Series C and Series D IntelliVAC versions. See [Module Status](#) for information about the IntelliVAC series in use.

Module Status

The Module Status is indicated with a Green status indicator if the module is functioning properly and has a valid configuration. If the module powers up with an invalid configuration the status indicator will be Red (flashing once), indicating a Fault condition which will not allow the contactor to close. If the module powers up properly and experiences an undervoltage condition when attempting to close the contactor or while the contactor is closed:

- **Series C** – the status indicator will be Red (Fault). If the contactor does not close properly, a Fault is generated, the status indicator turns Red, and inputs are inhibited until the module power is removed and reapplied.
- **Series D/E** – the status indicator will be yellow (flashing once). If the undervoltage condition is corrected during the selected TDUV interval (as set via DIP switch), then normal operation resumes.

If the processor has an internal fault, the status indicator will be Red, the outputs will be cleared, and the processor must be reset (input power must be cycled). If the reset is successful, the status indicator will be Green and the module will respond to the control inputs. The input command must be toggled before the module will respond to a new command (rising edge triggered).

For Series D/E, the Module Status indicator is also used to indicate various “Warning” conditions related to the contactor performance, see [Table 11 on page 36](#)).

The Module Status output relay has a normally open contact. The contact is open during a Fault condition (status indicator red), and closed during a healthy condition (status indicator green). The relay is open for some warning conditions, but closed for less severe issues.

The module states are summarized in [Table 10 on page 35](#) and [Table 11 on page 36](#).

Contactor Status

The Contactor Status is indicated with a yellow status indicator that is off until a CLOSE command is received. The yellow status indicator will stay on if the contactor closes properly, until the contactor is opened. If the processor has an internal fault, the status indicator will be red.

Contactor Status output relay has a normally open contact. The contact is open when the contactor is open (status indicator off), and closed when the contactor has received a close command (for 200 ms) or if it is closed (status indicator on).

IMPORTANT The Contactor will only respond to close command reapplications after the restart delay timer has expired.

The contactor states are summarized in [Table 10 on page 35](#) and [Table 11 on page 36](#).

IMPORTANT The status indicators are red/green types with both sections ON to produce yellow. If viewed from a sharp angle, you may see only green or red. Please view from directly in front of the module to ensure accurate color recognition.

Table 10 - IntelliVAC Status Indication (*Series C only*)

Conditions ⁽¹⁾ ⁽²⁾	Description	Module status		Contactor Status	
		Status Indicator Color	Relay	Status Indicator Color	Relay
Normal	Healthy Module and Contactor OPEN	Green	Closed	Off	Open
Normal	Healthy Module and Contactor CLOSED	Green	Closed	Yellow	Closed
Warning	Invalid Command Present ⁽³⁾	Yellow	Closed	Off	Open
Warning	Mechanical Latch Fail to Trip	Yellow	Open	Yellow	Closed
Fault	Power Up with Contactor CLOSED ⁽⁴⁾	Red - Flash 2 ⁽⁶⁾	Open	Yellow	Closed
Fault	Contactor Fails to Pick Up	Green	Open	Red - Flash1 ⁽⁷⁾	Open
Fault	Contactor Drop Out During Hold	Green	Open	Red - Flash2 ⁽⁶⁾	Open
Fault	Long Contactor Drop Out Time	Green	Open	Red - Flash3 ⁽⁸⁾	Open
Fault	Microcontroller Malfunction	Red	Open	Red	Open
Fault	Power Up with Invalid Dip Switch Configuration	Red - Flash 1 ⁽⁷⁾	Open	Off	Open
Fault	Undervoltage with a CLOSE Command Present ⁽⁵⁾	Red	Open	Off	Open

(1) Warning = Recoverable Condition – Remove and retry offending signal.

(2) Fault = Non-recoverable condition – Module power must be removed and reapplied.

(3) Invalid Command Types:

1. Close, Jog or Trip commands present during power up sequence.
2. Close or Jog command reapplied too quickly (before contactor opening sequence is verified). Allow at least 60 msec, plus drop out delay time, before reapplying these signals.
3. Close and Trip commands present simultaneously (valid with Mechanical Latch contactors only).

(4) Only for Electrically Held Contactor.

(5) Undervoltage conditions are defined on page 26.

(6) Flash 2 = 2 Consecutive Red status indicator flashes followed by a pause.

(7) Flash 1 = 1 Red status indicator flash followed by a pause.

(8) Flash 3 = 3 Consecutive Red status indicator flashes followed by a pause.

Table 11 - IntelliVAC Status Indication (Series D only)

Conditions (1) (2)	Description	Module Status		Contactor Status	
		Status Indicator Color	Status Relay	Status Indicator Color	Status Relay
Normal	Healthy Module and Contactor OPEN	Green	Closed	Off	Open
Normal	Healthy Module and Contactor CLOSED	Green	Closed	Yellow	Closed
Warning	Invalid Command Present ⁽³⁾	Yellow	Closed	Off	Open
Warning	Mechanical Latch Fail to Trip	Yellow	Closed	Yellow	Closed
Fault	Power Up with Contactor CLOSED ⁽⁴⁾	Red - Flash 2 ⁽⁶⁾	Open	Yellow	Closed
Warning	Contactor Fails to Pick Up	Yellow - R1 ⁽⁷⁾	Closed	Off / Yellow ⁽¹²⁾	Open / Closed ⁽¹²⁾
Warning	Contactor Drop Out During Hold	Yellow - R2 ⁽⁸⁾	Closed	Off / Yellow ⁽¹²⁾	Open / Closed ⁽¹²⁾
Warning	Long Contactor Drop Out Time	Yellow - R3 ⁽⁹⁾	Closed	Off / Yellow ⁽¹²⁾	Open / Closed ⁽¹²⁾
Fault	Microcontroller Malfunction	Red	Open	Red	Open
Fault	Power Up with Invalid Dip Switch Configuration	Red - Flash 1 ⁽¹⁰⁾	Open	Off	Open
Warning	Undervoltage with a CLOSE Command Present ⁽⁵⁾	Yellow - Flashing	Open / Closed ⁽¹¹⁾	Off / Yellow ⁽¹²⁾	Open / Closed ⁽¹²⁾

(1) Warnings will be cleared when a change of input state occurs, and the condition has been resolved.

(2) Faults require control power to be removed until the unit resets.

(3) Invalid Command Types:

1. Close, Jog or Trip commands present during power up sequence.

2. Close or Jog command reapplied too quickly (before contactor opening sequence is verified).

Allow at least 60 msec, plus drop out delay time, before reapplying these signals.

NOTE: Contactor will only respond to a close command reapplications after the restart delay timer has expired.

3. Close and Trip commands present simultaneously (valid with Mechanical Latch contactors only).

(4) Only for Electrically Held Contactor.

(5) Undervoltage conditions are defined on page 3-17.

(6) Flash 2 = 2 Consecutive Red status indicator flashes followed by a pause.

(7) Yellow – R1 = Yellow with 1 Red status indicator flash followed by a pause.

(8) Yellow – R2 = Yellow with 2 consecutive Red status indicator flashes followed by a pause.

(9) Yellow – R3 = Yellow with 3 consecutive Red status indicator flashes followed by a pause.

(10) Flash 1 = 1 Red status indicator flash followed by a pause.

(11) Open during undervoltage, Closed if voltage restored.

(12) Will reflect actual status of the contactor.

IntelliVAC Status Indication (Series E only)

Conditions (1) (2)	Description	Module status		Contactor Status	
		Status Indicator Color	Relay	Status Indicator Color	Relay
Normal	Healthy Module and Contactor OPEN	Green	Closed	Off	Open
Normal	Healthy Module and Contactor CLOSED	Green	Closed	Yellow	Closed
Warning	Invalid Command Present ⁽³⁾	Yellow	Closed	Off	Open
Warning	Mechanical Latch Fail to Trip	Yellow	Closed	Yellow	Closed
Fault	Power Up with Contactor CLOSED	Red - Flash 2 ⁽⁴⁾	Open	Yellow	Closed
Warning	Contactor Fails to Pick Up	Yellow - R1 ⁽⁵⁾	Closed	Off / Yellow ⁽¹⁰⁾	Open / Closed
Warning	Contactor Drop Out During Hold	Yellow - R2 ⁽⁶⁾	Closed	Off / Yellow	Open / Closed
Warning	Long Contactor Drop Out Time	Yellow - R3 ⁽⁷⁾	Closed	Off / Yellow	Open / Closed
Fault	Microcontroller Malfunction	Red	Open	Red	Open
Fault	Power Up with Invalid Dip Switch Configuration	Red - Flash 1 ⁽⁸⁾	Open	Off	Open
Fault	Contactor Fails to Drop Out	Red - Flash 3 ⁽⁸⁾	Open	Red	Open
Warning	Undervoltage with a CLOSE Command Present	Yellow - Flashing	Open / Closed ⁽⁹⁾	Off / Yellow	Open / Closed

(1) Warnings will be cleared when a change of input state occurs, and the condition has been resolved.

(2) Faults require control power to be removed until the unit resets.

(3) Yellow – R3 = Yellow with 3 consecutive Red flashes followed by a pause.

(4) Flash 2 = 2 Consecutive Red status indicator flashes followed by a pause.

(5) Flash 3 = 3 Consecutive Red status indicator flashes followed by a pause.

(6) Yellow – R1 = Yellow with 1 Red status indicator flash followed by a pause.

(7) Yellow – R2 = Yellow with 2 consecutive Red status indicator flashes followed by a pause.

(8) Will reflect actual status of the contactor.

(9) Invalid Command Types:

1. Close, Jog or Trip commands present during power up sequence.

2. Close or Jog command reapplied too quickly (before contactor opening sequence is verified).

Allow at least 60 msec, plus drop out delay time, before reapplying these signals.

NOTE: Contactor will only respond to a close command reapplications after the restart delay timer has expired.

3. Close and Trip commands present simultaneously (valid with Mechanical Latch contactors only).

(10) Open during undervoltage, Closed if voltage restored.

Table 12 - Module Troubleshooting

Problem or Trip Indicated	Indication of the following conditions	Possible Solutions
Contactor does not energize	<ul style="list-style-type: none"> Motor Protection device Trip contact activated Both status indicators 'Off' 	<ul style="list-style-type: none"> Investigate and reset Check Control Power and control fuse power Loose connections in control circuit Verify IntelliVAC power input plug is in place and properly seated Verify internal control fuse has not opened (See Figure 17 for location)
	<ul style="list-style-type: none"> Module status indicator 'Red' upon power up 	<ul style="list-style-type: none"> IntelliVAC faulted. Cycle control power to reset. Replace IntelliVAC if unsuccessful.
	<ul style="list-style-type: none"> Module status indicator 'Red Flash 1' upon power up. See Table 10...Table 12. 	<ul style="list-style-type: none"> Improper setting of dip switches. Check settings and cycle control power.
	<ul style="list-style-type: none"> Loose connection in control circuit. 	<ul style="list-style-type: none"> Verify contactor auxiliary installation. See Publication 1502-UM052-EN-P or 1502-UM051-EN-P – Auxiliary Contact Set-up Procedure. Verify circuit continuity (is contactor plug connected properly?)
Contactor closes momentarily and will not reclose.	<ul style="list-style-type: none"> Module status indicator 'Red' (Series C) and Contactor status indicator 'Off' or <ul style="list-style-type: none"> Module status indicator 'Yellow – Flashing' and Contactor status indicator 'Off' (Series D) 	<ul style="list-style-type: none"> Undervoltage fault (no TDUV), control voltage dipped below trip point. Verify voltage levels are 110 ... 240V AC, 110 ... 250V DC
Contactor fails to close.	<ul style="list-style-type: none"> Module status indicator 'Green' and Contactor status indicator 'Red Flash 1' (Series C) or <ul style="list-style-type: none"> Module status indicator 'Yellow-R1' (Series D) and Contactor status indicator 'Off'. Check internal control fuse. Verify IntelliVAC operation in test mode before applying Medium Voltage. See Figure 17 for location. See Table 10...Table 12. 	<ul style="list-style-type: none"> Coil damaged or connections are loose. Repair and cycle control power (Series C). Auxiliary Contact Assembly improperly adjusted. See Publication 1502-UM052-EN-P or 1502-UM051-EN-P – Auxiliary Contact Set-up Procedure. Cycle control power to reset (Series C). Armature Plate obstructed from closing to coil face. Verify no foreign material behind the armature plate. Cycle control power to reset.
	<ul style="list-style-type: none"> Both status indicators 'Off'. See Table 10...Table 12. 	<ul style="list-style-type: none"> Check internal control fuse. Verify IntelliVAC operation in test mode before applying Medium Voltage, see Figure 17 for location.
Contactor opens during operation	<ul style="list-style-type: none"> Motor Protection activated 	<ul style="list-style-type: none"> Investigate and reset.
	<ul style="list-style-type: none"> Module status indicator 'Red' (Series C) or <ul style="list-style-type: none"> 'Yellow – Flashing' (Series D). See Table 10...Table 12. 	<ul style="list-style-type: none"> Undervoltage fault (no TDUV), control voltage dipped below trip point. Verify voltage levels are 110 ... 240V AC, 110 ... 250V DC. With external capacitor and TDUV feature activated, undervoltage condition for longer than programmed TDUV time. Undervoltage fault activated.
	<ul style="list-style-type: none"> Module status indicator 'Green' and Contactor status indicator 'Red Flash 2' (Series C). See Table 10...Table 12. or <ul style="list-style-type: none"> Module status indicator 'Yellow – R2' and Contactor status indicator 'Off'. See Table 10...Table 12. 	<ul style="list-style-type: none"> Contactor Status feedback between Terminals 11 and 12 on the IntelliVAC has closed. The IntelliVAC will de-energize the coil, thinking the contactor has opened for other reasons.
	<ul style="list-style-type: none"> Both status indicators 'Off'. See Table 10...Table 12. 	<ul style="list-style-type: none"> Check control voltage and internal control fuse. (see Figure 17 for location).
Contactor does not open (mechanical latch)	<ul style="list-style-type: none"> Module status indicator 'Yellow' and Contactor status indicator 'Yellow'. See Table 10...Table 12. 	<ul style="list-style-type: none"> Trip mechanism is damaged. Inspect and replace if required. Check for loose connections in the control circuit.
Contactor does not open (electrically held)	<ul style="list-style-type: none"> Series C – Module status indicator 'Green' and Contactor status indicator 'Red Flash 3' Series D – Module status indicator 'Yellow – R3' and Contactor status indicator 'Yellow'. See Table 10...Table 12. 	<ul style="list-style-type: none"> Contactor welded closed or mechanisms binding. Inspect and repair if required.

See [Table 10 on page 35](#) (Series C) or [Table 11 on page 36](#) (Series D) for definition of Module status indicator states.

Spare Parts

Spare Parts List

IntelliVAC (electrically held) Series A ⁽¹⁾	1503VC-BMC1 - Order 1503VC-BMC4
IntelliVAC (mechanical latch) Series A ⁽¹⁾	1503VC-BMC2 - Order 1503VC-BMC4
IntelliVAC (electrically held and mechanical latch) Series B ⁽¹⁾	1503VC-BMC3 - Order 1503VC-BMC4
IntelliVAC (electrically held and mechanical latch) Series C and D ⁽¹⁾	1503VC-BMC4 - Order 1503VC-BMC4
IntelliVAC (electrically held and mechanical latch) Series E ⁽¹⁾	1503VC-BMC5
Internal Fuse: 6.3 A, 250V (Littlefuse 21506.3)	80174-902-14-R
Multi-pole connectors:	
2 pole (module power)	80174-014-01-R
4 pole (status outputs)	80174-014-03-R
12 pole (coil and I/O connections)	80174-014-11-R

(1) The Series Letter is printed on the large label on the right-hand side of the enclosure, beside the part number.

Optional Equipment

TDUV Capacitor⁽¹⁾	
110/120V AC control (1650 µF)	80158-779-51-R
220/240V AC control (330 µF)	80158-779-52-R

(1) Includes mounting bracket and terminal guards.

Notes:

Contactor Drop-out Time Settings

Typical Settings

The contactor drop-out time settings shown in the following table are typical minimum values used when the power fuses are provided as part of a complete MV controller from Rockwell Automation. The recommendations are based on Ferraz-Shawmut power fuses. Other fuse types may require alternate drop-out time settings.

The IntelliVAC module DIP switches are designed to provide the minimum drop-out times shown, see [Chapter 4](#).

Table 13 - Typical Contactor Drop-Out Time Settings

IMPORTANT The drop-out time is chosen to be equal to or greater than the intersection of the rated contactor interrupting current and the fuse melt time curve (except where noted *).

Fuse Rating		Contactor Drop-out Time Setting (ms)		
Voltage	Designation	400A	800A	
<5000	2R	50	50	
	3R			
	4R			
	6R			
	9R			
	12R			
	18R			
	19R			
	24R	100	75	
	32R	240		
	38R	(1)		
	48X	(1)		
	57X	(1)		200
	2 x 24R	(1)		100
	2 x 32R	(1)		240*
	2 x 38R	(1)		(1)
2 x 48X	(1)	(1)		
2 x 57X	(1)	(1)		

Fuse Rating		Contactor Drop-out Time Setting (ms)		
Voltage	Designation	400A	800A	
<5000	20E	50	50	
	30E			
	40E			
	50E			
	65E			
	80E			
	100E			
	125E			
	150E			
	175E			
	200E			
	250E			
	300E			
	350E	75	75	
	400E	100		
	450E	130		
	500E	240		
	600E	240*		
	750E	(1)		200
	900E	(1)		240*
	2 x 250E	(1)		50
	2 x 300E	(1)		75
	2 x 350E	(1)		75
	2 x 400E	(1)		100
2 x 450E	(1)	130		
2 x 500E	(1)	240		
2 x 600E	(1)	240		
2 x 750E	(1)	(1)		
2 x 900E	(1)	(1)		

(1) Fuse not suitable for use with contactor

IMPORTANT The drop-out time is chosen to be equal to or greater than the intersection of the rated contactor interrupting current and the fuse melt time curve (except where noted *).

Fuse Rating		Contactor Drop-out Time Setting (ms)		
Voltage	Designation	400A	800A	
7200	2R	50	50	
	3R			
	4R			
	6R			
	9R			
	12R			
	18R			75
	24R			150
	32R	240 *		
	38R	(1)	75	
	48X	(1)	150	
	57X	(1)	200	
	2 x 18R	(1)	50	
	2 x 24R	(1)	130	
	2 x 32R	(1)	240 *	
	2 x 38R	(1)	(1)	
2 x 48X	(1)	(1)		
2 x 57X	(1)	(1)		
8250	10E	50	50	
	15E			
	20E			
	25E			
	30E			
	40E			
	50E			
	65E			
	80E			
	100E			
	125E			
	150E			
	175E			
200E				

(1) Fuse not suitable for use with contactor.

IMPORTANT The drop-out time is chosen to be equal to or greater than the intersection of the rated contactor interrupting current and the fuse melt time curve (except where noted *).

Notes:

Rockwell Automation Support

Rockwell Automation provides technical information on the Web to assist you in using its products.

At <http://www.rockwellautomation.com/support> you can find technical and application notes, sample code, and links to software service packs. You can also visit our Support Center at <https://rockwellautomation.custhelp.com/> for software updates, support chats and forums, technical information, FAQs, and to sign up for product notification updates.

In addition, we offer multiple support programs for installation, configuration, and troubleshooting. For more information, contact your local distributor or Rockwell Automation representative, or visit <http://www.rockwellautomation.com/services/online-phone>.

Installation Assistance

If you experience a problem within the first 24 hours of installation, review the information that is contained in this manual. You can contact Customer Support for initial help in getting your product up and running.

United States or Canada	1.440.646.3434
Outside United States or Canada	Use the Worldwide Locator at http://www.rockwellautomation.com/rockwellautomation/support/overview.page , or contact your local Rockwell Automation representative.

New Product Satisfaction Return

Rockwell Automation tests all of its products to help ensure that they are fully operational when shipped from the manufacturing facility. However, if your product is not functioning and needs to be returned, follow these procedures.

United States	Contact your distributor. You must provide a Customer Support case number (call the phone number above to obtain one) to your distributor to complete the return process.
Outside United States	Please contact your local Rockwell Automation representative for the return procedure.

Documentation Feedback

Your comments will help us serve your documentation needs better. If you have any suggestions on how to improve this document, complete this form, publication [RA-DU002](#), available at <http://www.rockwellautomation.com/literature/>.

Medium Voltage Products, 135 Dundas Street, Cambridge, ON, N1R 5X1 Canada, Tel: (1) 519.740.4100, Fax: (1) 519.623.8930
Online: www.ab.com/mvb

Rockwell Automation maintains current product environmental information on its website at <http://www.rockwellautomation.com/rockwellautomation/about-us/sustainability-ethics/product-environmental-compliance.page>.

www.rockwellautomation.com

Power, Control and Information Solutions Headquarters

Americas: Rockwell Automation, 1201 South Second Street, Milwaukee, WI 53204-2496 USA, Tel: (1) 414.382.2000, Fax: (1) 414.382.4444
Europe/Middle East/Africa: Rockwell Automation NV, Pegasus Park, De Kleetlaan 12a, 1831 Diegem, Belgium, Tel: (32) 2 663 0600, Fax: (32) 2 663 0640
Asia Pacific: Rockwell Automation, Level 14, Core F, Cyberport 3, 100 Cyberport Road, Hong Kong, Tel: (852) 2887 4788, Fax: (852) 2508 1846

Publication 1503-UM053C-EN-P - March 2015

Supersedes Publication 1503-UM053B-EN-P - June 2013

Copyright © 2015 Rockwell Automation, Inc. All rights reserved. Printed in Canada.