

Switch Amplifier

KFD2-SR2-Ex2.W

PL d

SIL 2

- 2-channel isolated barrier
- 24 V DC supply (Power Rail)
- Dry contact or NAMUR inputs
- Relay contact output
- Line fault detection (LFD)
- Reversible mode of operation
- Up to SIL 2 acc. to IEC 61508/IEC 61511
- Up to SIL 2 acc. to IEC/EN 62061
- Up to PL d acc. to EN/ISO 13849



Function

This isolated barrier is used for intrinsic safety applications. It transfers digital signals (NAMUR sensors/mechanical contacts) from a hazardous area to a safe area. The proximity sensor or switch controls a change-over relay contact for the load in the non-explosion hazardous area. The normal output state can be reversed using switches S1 and S2. Switch S3 is used to enable or disable line fault detection of the field circuit. During an error condition, the relays revert to their de-energized state and the LEDs indicate the fault according to NAMUR NE44. A unique collective error messaging feature is available when used with the Power Rail system.

Technical Data

General specifications			
Signal type	Digital Input		
Functional safety related parameters			
Safety Integrity Level (SIL)	SIL 2		
SIL Claim Level	SIL 2 , see functional safety manual		
Performance level (PL)	PL d , see functional safety manual		
Supply			
Connection	Power Rail or terminals 14+, 15-		
Rated voltage	U_r	19 ... 30 V DC	
Ripple	≤ 10 %		
Rated current	I_r	≤ 50 mA	
Power dissipation	≤ 1 W		
Power consumption	≤ 1 W		
Input			
Connection side	field side		
Connection	terminals 1+, 2+, 3-; 4+, 5+, 6-		
Rated values	acc. to EN 60947-5-6 (NAMUR)		
Open circuit voltage/short-circuit current	approx. 8 V DC / approx. 8 mA		
Switching point/switching hysteresis	1.2 ... 2.1 mA / approx. 0.2 mA		
Line fault detection	breakage $I \leq 0.1$ mA , short-circuit $I > 6$ mA		
Pulse/Pause ratio	min. 20 ms / min. 20 ms		
Output			
Connection side	control side		
Connection	output I: terminals 7, 8, 9 ; output II: terminals 10, 11, 12		
Output I, II	signal, relay		
Contact loading	250 V AC/2 A/cos $\phi > 0.75$; 126.5 V AC/4 A/cos $\phi > 0.75$; 40 V DC/2 A resistive load		

Release date: 2020-04-07 Date of issue: 2020-04-07 Filename: 203355_eng.pdf

Refer to "General Notes Relating to Pepperl+Fuchs Product Information".

Pepperl+Fuchs Group
www.pepperl-fuchs.com

USA: +1 330 486 0002
pa-info@us.pepperl-fuchs.com

Germany: +49 621 776 2222
pa-info@de.pepperl-fuchs.com

Singapore: +65 6779 9091
pa-info@sg.pepperl-fuchs.com

PEPPERL+FUCHS

Technical Data

Minimum switch current		2 mA / 24 V DC
Energized/De-energized delay		approx. 20 ms / approx. 20 ms
Mechanical life		10 ⁷ switching cycles
Collective error message		Power Rail
Transfer characteristics		
Switching frequency		≤ 10 Hz
Galvanic isolation		
Input/Output		reinforced insulation according to IEC/EN 61010-1, rated insulation voltage 300 V _{eff}
Input/power supply		reinforced insulation according to IEC/EN 61010-1, rated insulation voltage 300 V _{eff}
Output/power supply		reinforced insulation according to IEC/EN 61010-1, rated insulation voltage 300 V _{eff}
Output/Output		reinforced insulation according to IEC/EN 61010-1, rated insulation voltage 300 V _{eff}
Indicators/settings		
Display elements		LEDs
Control elements		DIP-switch
Configuration		via DIP switches
Labeling		space for labeling at the front
Directive conformity		
Electromagnetic compatibility		
Directive 2014/30/EU		EN 61326-1:2013 (industrial locations)
Low voltage		
Directive 2014/35/EU		EN 61010-1:2010
Conformity		
Electromagnetic compatibility		NE 21:2017 , EN 61326-3-1:2017 , EN IEC 61326-3-2:2018
Degree of protection		IEC 60529:1989+A1:1999+A2:2013
Functional safety		IEC/EN 61508:2010
Input		EN 60947-5-6:2000
Ambient conditions		
Ambient temperature		-20 ... 70 °C (-4 ... 158 °F)
Mechanical specifications		
Degree of protection		IP20
Connection		screw terminals
Mass		approx. 150 g
Dimensions		20 x 119 x 115 mm (0.8 x 4.7 x 4.5 inch) , housing type B2
Mounting		on 35 mm DIN mounting rail acc. to EN 60715:2001
Data for application in connection with hazardous areas		
EU-type examination certificate		PTB 00 ATEX 2080
Marking		⊕ II (1)G [Ex ia Ga] IIC ⊕ II (1)D [Ex ia Da] IIIC ⊕ I (M1) [Ex ia Ma] I
Input		Ex ia
Voltage	U _o	10.5 V
Current	I _o	13 mA
Power	P _o	34 mW (linear characteristic)
Supply		
Maximum safe voltage	U _m	253 V AC / 125 V DC (Attention! U _m is no rated voltage.)
Output		
Maximum safe voltage	U _m	253 V AC (Attention! The rated voltage can be lower.)
Fault indication output		
Maximum safe voltage	U _m	40 V DC (Attention! U _m is no rated voltage.)
Certificate		
Marking		⊕ II (3)G [Ex ic Gc] IIC
Input		Ex ic
Voltage	U _o	10.5 V
Current	I _o	13 mA

Release date: 2020-04-07 Date of issue: 2020-04-07 Filename: 203355_eng.pdf

Refer to "General Notes Relating to Pepperl+Fuchs Product Information".

Pepperl+Fuchs Group
www.pepperl-fuchs.comUSA: +1 330 486 0002
pa-info@us.pepperl-fuchs.comGermany: +49 621 776 2222
pa-info@de.pepperl-fuchs.comSingapore: +65 6779 9091
pa-info@sg.pepperl-fuchs.com

PEPPERL+FUCHS

Technical Data

Power	P _o	34 mW (linear characteristic)
Certificate		TÜV 99 ATEX 1493 X
Marking		Ⓜ II 3G Ex ec nC IIC T4 Gc
Output		
Contact loading		50 V AC/4 A/cos φ > 0.7; 40 V DC/2 A resistive load
Galvanic isolation		
Input/Output		safe electrical isolation acc. to IEC/EN 60079-11, voltage peak value 375 V
Input/power supply		safe electrical isolation acc. to IEC/EN 60079-11, voltage peak value 375 V
Directive conformity		
Directive 2014/34/EU		EN IEC 60079-0:2018 , EN 60079-7:2015+A1:2018 , EN 60079-11:2012 , EN IEC 60079-15:2019

International approvals		
FM approval		
FM certificate		FM19US0207X
Control drawing		116-0035
UL approval		E106378
Control drawing		116-0473 (cULus)
Contact loading		250 V AC/2 A/cos φ > 0.75; 126.5 V AC/4 A/cos φ > 0.75; 30 V DC/2 A resistive load
Ambient temperature		-20 ... 60 °C (-4 ... 140 °F)
IECEX approval		
IECEX certificate		IECEX PTB 11.0034 , IECEX TUN 19.0013X
IECEX marking		[Ex ia Ga] IIC [Ex ia Da] IIC [Ex ia Ma] I Ex ec nC IIC T4 Gc

General information		
Supplementary information		Observe the certificates, declarations of conformity, instruction manuals, and manuals where applicable. For information see www.pepperl-fuchs.com .

Assembly

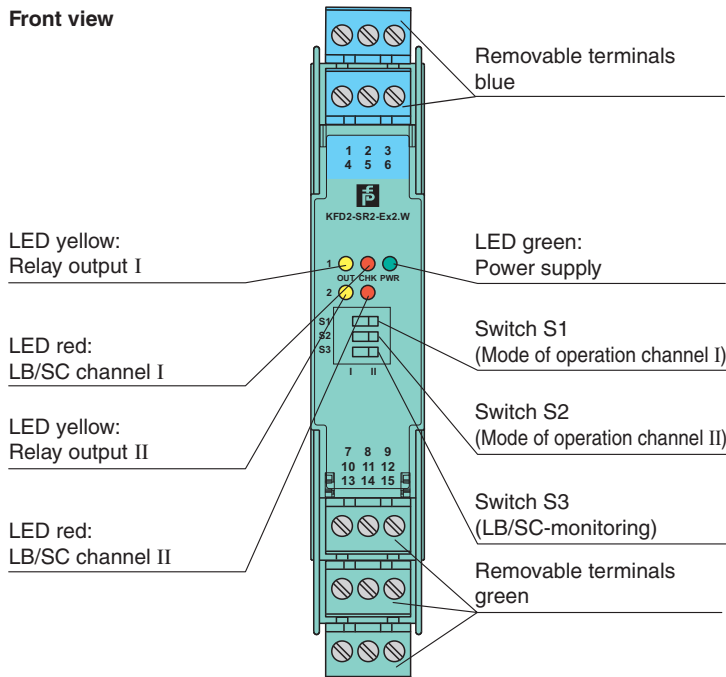

Release date: 2020-04-07 Date of issue: 2020-04-07 Filename: 203355_eng.pdf

Refer to "General Notes Relating to Pepperl+Fuchs Product Information".

Pepperl+Fuchs Group
www.pepperl-fuchs.com

USA: +1 330 486 0002
pa-info@us.pepperl-fuchs.com

Germany: +49 621 776 2222
pa-info@de.pepperl-fuchs.com

Singapore: +65 6779 9091
pa-info@sg.pepperl-fuchs.com

Connection

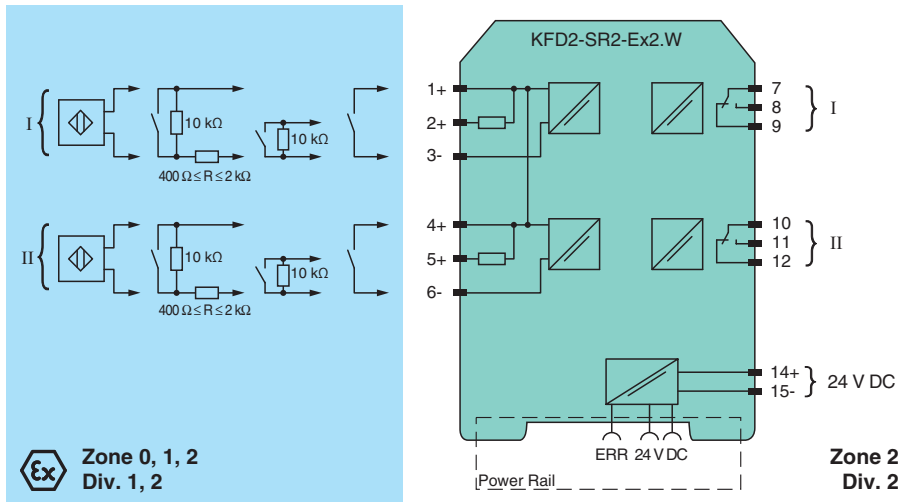

Accessories

	KFD2-EB2	Power Feed Module
	UPR-03	Universal Power Rail with end caps and cover, 3 conductors, length: 2 m
	UPR-03-M	Universal Power Rail with end caps and cover, 3 conductors, length: 1,6 m
	UPR-03-S	Universal Power Rail with end caps and cover, 3 conductors, length: 0.8 m
	K-DUCT-BU	
	K-DUCT-BU-UPR-03	Profile rail with UPR-03- * insert, 3 conductors, wiring comb field side blue

Release date: 2020-04-07 Date of issue: 2020-04-07 Filename: 203355_eng.pdf

Configuration

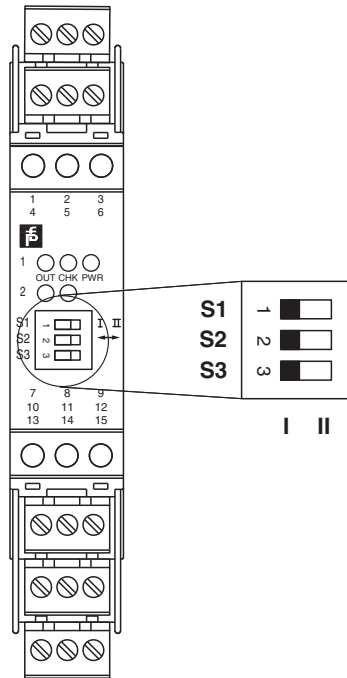

Switch position

S	Function		Position
1	Mode of operation output I (relay) energized	with high input current	I
		with low input current	II
2	Mode of operation output II (relay) energized	with high input current	I
		with low input current	II
3	Line fault detection	ON	I
		OFF	II

Operating states

Control circuit	Input signal
Initiator high impedance/contact opened	low input current
Initiator low impedance/contact closed	high input current
Lead breakage, lead short circuit	Line fault

Factory setting: switch 1, 2 and 3 in position I

Characteristic Curve

Maximum switching power of output contacts

Release date: 2020-04-07 Date of issue: 2020-04-07 Filename: 203355_eng.pdf

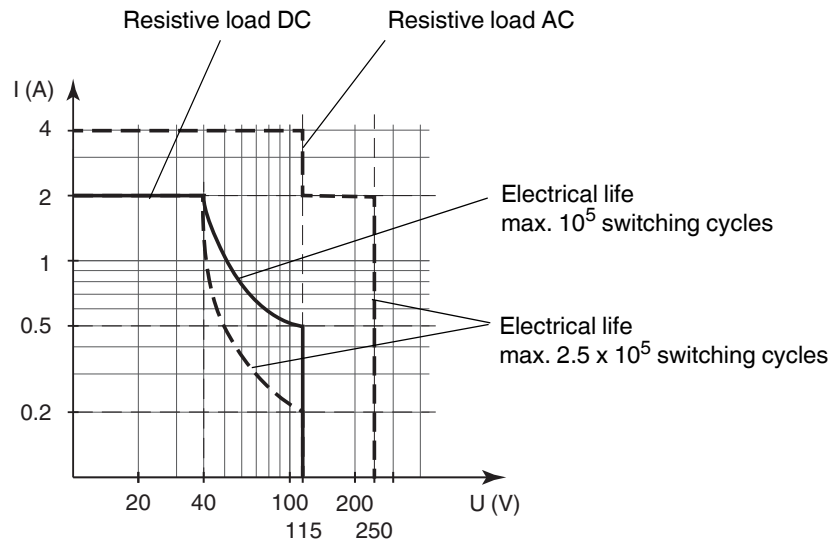

The maximum number of switching cycles is depending on the electrical load and may be higher when reduced currents and voltages are applied.

Release date: 2020-04-07 Date of issue: 2020-04-07 Filename: 203355_eng.pdf