

KI505A

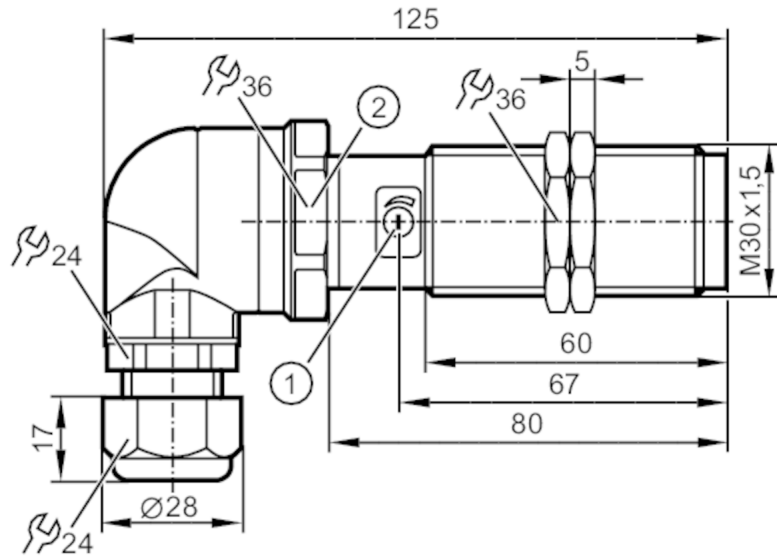

Capacitive sensor

KIE4150NCPKG/3D



- 1 potentiometer
- 2 Tightening torque 10 Nm



Product characteristics

Electrical design	PNP
Output function	complementary
Sensing range [mm]	15
Housing	Threaded type
Dimensions [mm]	M30 x 1.5 / L = 125

Electrical data

Operating voltage [V]	10...30 DC
Current consumption [mA]	< 20
Protection class	III
Reverse polarity protection	yes

Outputs

Electrical design	PNP
Output function	complementary
Max. voltage drop switching output DC [V]	2.5
Max. leakage current [mA]	0.1
Permanent current rating of switching output DC [mA]	200
Switching frequency DC [Hz]	10
Short-circuit proof	yes
Overload protection	yes

KI505A



Capacitive sensor

KIE4150NCPKG/3D

Monitoring range		
Sensing range	[mm]	15
Sensing range adjustable		yes
Factory setting sensing range	[mm]	15
Real sensing range Sr	[mm]	15 ± 10 %
Accuracy / deviations		
Hysteresis	[% of Sr]	1...15
Switch-point drift	[% of Sr]	-20...20
Operating conditions		
Ambient temperature	[°C]	-20...60
Protection		IP 65; IP 67
Tests / approvals		
ATEX marking	II 3D Ex tc IIIC T90°C Dc X	
EMC	EN 61000-4-2 ESD	kV / 8 kV AD
	EN 61000-4-3 HF radiated	3 V/m
	EN 61000-4-4 Burst	2 kV
	EN 61000-4-6 HF conducted	3 V
	EN 55011	class B
IEC 60255-5	1 kV line to line, Ri: 500 Ohm	
MTTF	[years]	463
Mechanical data		
Weight	[g]	155
Housing		Threaded type
Mounting		non-flush mountable
Dimensions	[mm]	M30 x 1.5 / L = 125
Thread designation		M30 x 1.5
Material		PBT; PA
Displays / operating elements		
Display	Switching status	1 x LED, yellow
Accessories		
Accessories (supplied)		lock nuts: 2
Remarks		
Pack quantity		1 pcs.

KI505A



Capacitive sensor

KIE4150NCPKG/3D

Electrical connection

terminals: 0.34...1.5 mm²; Cable sheath: Ø 5...9 mm; Cable gland: M20 X 1.5

Connection

