



General-Purpose AC Servo

MITSUBISHI SERVO AMPLIFIERS & MOTORS
MELSERVO-J4

General-Purpose Interface AC Servo

MODEL

MR-J4- A

SERVO AMPLIFIER

INSTRUCTION MANUAL

● Safety Instructions ●

Please read the instructions carefully before using the equipment.

To use the equipment correctly, do not attempt to install, operate, maintain, or inspect the equipment until you have read through this Instruction Manual, Installation guide, and appended documents carefully. Do not use the equipment until you have a full knowledge of the equipment, safety information and instructions. In this Instruction Manual, the safety instruction levels are classified into "WARNING" and "CAUTION".



Indicates that incorrect handling may cause hazardous conditions, resulting in death or severe injury.



Indicates that incorrect handling may cause hazardous conditions, resulting in medium or slight injury to personnel or may cause physical damage.

Note that the CAUTION level may lead to a serious consequence according to conditions. Please follow the instructions of both levels because they are important to personnel safety. What must not be done and what must be done are indicated by the following diagrammatic symbols.



Indicates what must not be done. For example, "No Fire" is indicated by .



Indicates what must be done. For example, grounding is indicated by .

In this Instruction Manual, instructions at a lower level than the above, instructions for other functions, and so on are classified into "POINT".

After reading this Instruction Manual, keep it accessible to the operator.

1. To prevent electric shock, note the following

WARNING

- Before wiring and inspections, turn off the power and wait for 15 minutes or more until the charge lamp turns off. Then, confirm that the voltage between P+ and N- is safe with a voltage tester and others. Otherwise, an electric shock may occur. In addition, when confirming whether the charge lamp is off or not, always confirm it from the front of the servo amplifier.
- Ground the servo amplifier and servo motor securely.
- Any person who is involved in wiring and inspection should be fully competent to do the work.
- Do not attempt to wire the servo amplifier and servo motor until they have been installed. Otherwise, it may cause an electric shock.
- Do not operate switches with wet hands. Otherwise, it may cause an electric shock.
- The cables should not be damaged, stressed, loaded, or pinched. Otherwise, it may cause an electric shock.
- During power-on or operation, do not open the front cover of the servo amplifier. Otherwise, it may cause an electric shock.
- Do not operate the servo amplifier with the front cover removed. High-voltage terminals and charging area are exposed and you may get an electric shock.
- Except for wiring and periodic inspection, do not remove the front cover of the servo amplifier even if the power is off. The servo amplifier is charged and you may get an electric shock.
- To prevent an electric shock, always connect the protective earth (PE) terminal (marked ⊕) of the servo amplifier to the protective earth (PE) of the cabinet.
- When using a residual current device (RCD), select the type B.
- To avoid an electric shock, insulate the connections of the power supply terminals.

2. To prevent fire, note the following

CAUTION

- Install the servo amplifier, servo motor, and regenerative resistor on incombustible material. Installing it directly or close to combustibles will lead to a fire.
- Always connect a magnetic contactor between the power supply and the main circuit power supply (L1, L2, and L3) of the servo amplifier, in order to configure a circuit that shuts down the power supply on the side of the servo amplifier's power supply. If a magnetic contactor is not connected, continuous flow of a large current may cause a fire when the servo amplifier malfunctions.
- When using the regenerative resistor, switch power off with the alarm signal. Not doing so may cause a fire when a regenerative transistor malfunctions or the like may overheat the regenerative resistor.
- Provide adequate protection to prevent screws and other conductive matter, oil and other combustible matter from entering the servo amplifier and servo motor.
- Always connect a molded case circuit breaker to the power supply of the servo amplifier.

3. To prevent injury, note the following

|  CAUTION |
|--|
| <ul style="list-style-type: none"> ● Only the voltage specified in the Instruction Manual should be applied to each terminal. Otherwise, a burst, damage, etc. may occur. ● Connect cables to the correct terminals. Otherwise, a burst, damage, etc. may occur. ● Ensure that polarity (+/-) is correct. Otherwise, a burst, damage, etc. may occur. ● The servo amplifier heat sink, regenerative resistor, servo motor, etc. may be hot while power is on or for some time after power-off. Take safety measures, e.g. provide covers, to prevent accidental contact of hands and parts (cables, etc.) with them. |

4. Additional instructions

The following instructions should also be fully noted. Incorrect handling may cause a fault, injury, electric shock, etc.

(1) Transportation and installation

|  CAUTION | | | | | |
|--|---|-----------|---------------------------------|---------|--------------------------------|
| <ul style="list-style-type: none"> ● Transport the products correctly according to their mass. ● Stacking in excess of the specified number of product packages is not allowed. ● Do not hold the front cover when transporting the servo amplifier. Otherwise, it may drop. ● Install the servo amplifier and the servo motor in a load-bearing place in accordance with the Instruction Manual. ● Do not get on or put heavy load on the equipment. ● The equipment must be installed in the specified direction. ● Leave specified clearances between the servo amplifier and the cabinet walls or other equipment. ● Do not install or operate the servo amplifier and servo motor which have been damaged or have any parts missing. ● Do not block the intake and exhaust areas of the servo amplifier. Otherwise, it may cause a malfunction. ● Do not drop or strike the servo amplifier and servo motor. Isolate them from all impact loads. ● When you keep or use the equipment, please fulfill the following environment. | | | | | |
| Items | Environment | | | | |
| Ambient temperature | <table border="1" style="width: 100%; border-collapse: collapse;"> <tr> <td style="width: 15%; padding: 2px;">Operation</td> <td style="padding: 2px;">0 °C to 55 °C (non-freezing)</td> </tr> <tr> <td style="padding: 2px;">Storage</td> <td style="padding: 2px;">-20 °C to 65 °C (non-freezing)</td> </tr> </table> | Operation | 0 °C to 55 °C (non-freezing) | Storage | -20 °C to 65 °C (non-freezing) |
| Operation | 0 °C to 55 °C (non-freezing) | | | | |
| Storage | -20 °C to 65 °C (non-freezing) | | | | |
| Ambient humidity | <table border="1" style="width: 100%; border-collapse: collapse;"> <tr> <td style="width: 15%; padding: 2px;">Operation</td> <td style="padding: 2px;">90% RH or less (non-condensing)</td> </tr> <tr> <td style="padding: 2px;">Storage</td> <td style="padding: 2px;"></td> </tr> </table> | Operation | 90% RH or less (non-condensing) | Storage | |
| Operation | 90% RH or less (non-condensing) | | | | |
| Storage | | | | | |
| Ambience | Indoors (no direct sunlight), free from corrosive gas, flammable gas, oil mist, dust, and dirt | | | | |
| Altitude | Max. 1000 m above sea level | | | | |
| Vibration | 5.9 m/s ² or less at 10 Hz to 55 Hz (directions of X, Y, and Z axes) | | | | |
| <ul style="list-style-type: none"> ● When the equipment has been stored for an extended period of time, consult your local sales office. ● When handling the servo amplifier, be careful about the edged parts such as corners of the servo amplifier. ● The servo amplifier must be installed in the metal cabinet. | | | | | |

(2) Wiring

⚠ CAUTION

- Wire the equipment correctly and securely. Otherwise, the servo motor may operate unexpectedly.
- Do not install a power capacitor, surge killer, or radio noise filter (FR-BIF option) on the servo amplifier output side.
- To avoid a malfunction, connect the wires to the correct phase terminals (U, V, and W) of the servo amplifier and servo motor.
- Connect the servo amplifier power output (U, V, and W) to the servo motor power input (U, V, and W) directly. Do not let a magnetic contactor, etc. intervene. Otherwise, it may cause a malfunction.

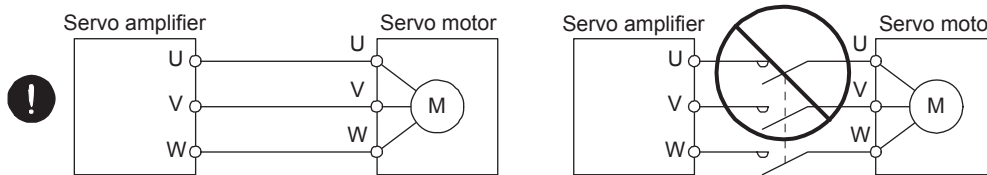

- The surge absorbing diode installed to the DC relay for control output should be fitted in the specified direction. Otherwise, the emergency stop and other protective circuits may not operate.

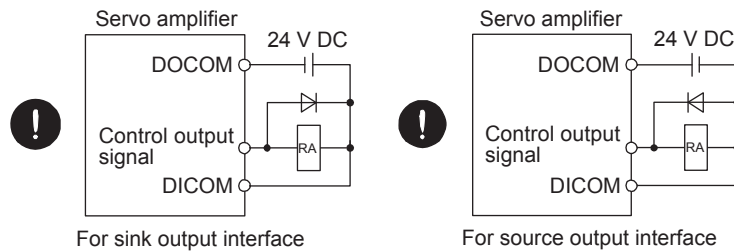

- When the cable is not tightened enough to the terminal block, the cable or terminal block may generate heat because of the poor contact. Be sure to tighten the cable with specified torque.

(3) Test run and adjustment

⚠ CAUTION

- Before operation, check the parameter settings. Improper settings may cause some machines to perform unexpected operation.
- Never adjust or change the parameter values extremely as it will make operation unstable.

(4) Usage

⚠ CAUTION

- Provide an external emergency stop circuit to ensure that operation can be stopped and power switched off immediately.
- Do not disassemble, repair, or modify the equipment.
- Before resetting an alarm, make sure that the run signal of the servo amplifier is off in order to prevent a sudden restart. Otherwise, it may cause an accident.
- Use a noise filter, etc. to minimize the influence of electromagnetic interference. Electromagnetic interference may be given to the electronic equipment used near the servo amplifier.

⚠ CAUTION

- Burning or breaking a servo amplifier may cause a toxic gas. Do not burn or break it.
- Use the servo amplifier with the specified servo motor.
- The electromagnetic brake on the servo motor is designed to hold the motor shaft and should not be used for ordinary braking.
- For such reasons as service life and mechanical structure (e.g. where a ball screw and the servo motor are coupled via a timing belt), the electromagnetic brake may not hold the motor shaft. To ensure safety, install a stopper on the machine side.

(5) Corrective actions

⚠ CAUTION

- When it is assumed that a hazardous condition may occur due to a power failure or product malfunction, use a servo motor with an electromagnetic brake or external brake to prevent the condition.
- Configure an electromagnetic brake circuit so that it is activated also by an external EMG stop switch.

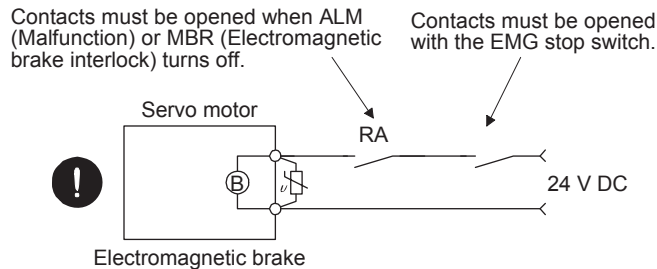

- When any alarm has occurred, eliminate its cause, ensure safety, and deactivate the alarm before restarting operation.
- Provide an adequate protection to prevent unexpected restart after an instantaneous power failure.

(6) Maintenance, inspection and parts replacement

⚠ CAUTION

- With age, the electrolytic capacitor of the servo amplifier will deteriorate. To prevent a secondary accident due to a malfunction, it is recommended that the electrolytic capacitor be replaced every 10 years when it is used in general environment. Please contact your local sales office.

(7) General instruction

- To illustrate details, the equipment in the diagrams of this Instruction Manual may have been drawn without covers and safety guards. When the equipment is operated, the covers and safety guards must be installed as specified. Operation must be performed in accordance with this Specifications and Instruction Manual.

● DISPOSAL OF WASTE ●

Please dispose a servo amplifier, battery (primary battery) and other options according to your local laws and regulations.

EEP-ROM life

The number of write times to the EEP-ROM, which stores parameter settings, etc., is limited to 100,000. If the total number of the following operations exceeds 100,000, the servo amplifier may malfunction when the EEP-ROM reaches the end of its useful life.

- Write to the EEP-ROM due to parameter setting changes
- Write to the EEP-ROM due to device changes

STO function of the servo amplifier

When using the STO function of the servo amplifier, refer to chapter 13.
For the MR-J3-D05 safety logic unit, refer to appendix 7.

COMPLIANCE WITH CE MARKING

Refer to Appendix 4 for the compliance with CE marking.

COMPLIANCE WITH UL/CSA STANDARD

Refer to Appendix 5 for the compliance with UL/CSA standard.

<<About the manuals>>

You must have this Instruction Manual and the following manuals to use this servo. Ensure to prepare them to use the servo safely.

Relevant manuals

| Manual name | Manual No. |
|---|---------------|
| MELSERVO-J4 Series Instructions and Cautions for Safe Use of AC Servos (Packed with the servo amplifier) | IB(NA)0300175 |
| MELSERVO-J4 SERVO AMPLIFIER INSTRUCTION MANUAL (TROUBLESHOOTING) | SH(NA)030109 |
| MELSERVO Servo Motor Instruction Manual (Vol. 3) | SH(NA)030113 |
| EMC Installation Guidelines | IB(NA)67310 |

<<Wiring>>

Wires mentioned in this Instruction Manual are selected based on the ambient temperature of 40 °C.

<<U.S. customary units>>

U.S. customary units are not shown in this manual. Convert the values if necessary according to the following table.

| Quantity | SI (metric) unit | U.S. customary unit |
|-------------------------------|--|------------------------------|
| Mass | 1 [kg] | 2.2046 [lb] |
| Length | 1 [mm] | 0.03937 [in] |
| Torque | 1 [N·m] | 141.6 [oz·in] |
| Moment of inertia | 1 [($\times 10^{-4}$ kg·m ²)] | 5.4675 [oz·in ²] |
| Load (thrust load/axial load) | 1 [N] | 0.2248 [lbf] |
| Temperature | N [°C] \times 9/5 + 32 | N [°F] |

CONTENTS

| | |
|---|---------------------|
| 1. FUNCTIONS AND CONFIGURATION | 1- 1 to 1-20 |
| 1.1 Summary..... | 1- 1 |
| 1.2 Function block diagram..... | 1- 2 |
| 1.3 Servo amplifier standard specifications | 1- 4 |
| 1.4 Combinations of servo amplifiers and servo motors | 1- 6 |
| 1.5 Function list..... | 1- 7 |
| 1.6 Model designation..... | 1- 9 |
| 1.7 Structure | 1-10 |
| 1.7.1 Parts identification..... | 1-10 |
| 1.7.2 Removal and reinstallation of the front cover..... | 1-14 |
| 1.8 Configuration including auxiliary equipment..... | 1-16 |
| 2. INSTALLATION | 2- 1 to 2- 6 |
| 2.1 Installation direction and clearances | 2- 2 |
| 2.2 Keep out foreign materials..... | 2- 3 |
| 2.3 Encoder cable stress | 2- 4 |
| 2.4 Inspection items | 2- 4 |
| 2.5 Parts having service lives | 2- 5 |
| 3. SIGNALS AND WIRING | 3- 1 to 3-62 |
| 3.1 Input power supply circuit | 3- 2 |
| 3.2 I/O signal connection example..... | 3- 7 |
| 3.2.1 Position control mode..... | 3- 7 |
| 3.2.2 Speed control mode | 3- 9 |
| 3.2.3 Torque control mode | 3-11 |
| 3.3 Explanation of power supply system | 3-13 |
| 3.3.1 Signal explanations | 3-13 |
| 3.3.2 Power-on sequence | 3-14 |
| 3.3.3 Wiring CNP1, CNP2, and CNP3..... | 3-15 |
| 3.4 Connectors and pin assignment | 3-17 |
| 3.5 Signal (device) explanations..... | 3-21 |
| 3.6 Detailed description of signals..... | 3-30 |
| 3.6.1 Position control mode..... | 3-30 |
| 3.6.2 Speed control mode | 3-35 |
| 3.6.3 Torque control mode | 3-37 |
| 3.6.4 Position/speed control switching mode..... | 3-40 |
| 3.6.5 Speed/torque control switching mode..... | 3-42 |
| 3.6.6 Torque/position control switching mode..... | 3-44 |
| 3.7 Forced stop deceleration function | 3-45 |
| 3.7.1 Forced stop deceleration function (SS1)..... | 3-45 |
| 3.7.2 Base circuit shut-off delay time function | 3-47 |
| 3.7.3 Vertical axis freefall prevention function | 3-48 |
| 3.7.4 Residual risks of the forced stop function (EM2) | 3-48 |
| 3.8 Alarm occurrence timing chart..... | 3-49 |
| 3.8.1 When you use the forced stop deceleration function..... | 3-49 |

| | | |
|--------|--|------|
| 3.8.2 | When you do not use the forced stop deceleration function..... | 3-50 |
| 3.9 | Interfaces | 3-51 |
| 3.9.1 | Internal connection diagram..... | 3-51 |
| 3.9.2 | Detailed description of interfaces..... | 3-52 |
| 3.9.3 | Source I/O interfaces | 3-56 |
| 3.10 | Servo motor with an electromagnetic brake | 3-57 |
| 3.10.1 | Safety precautions | 3-57 |
| 3.10.2 | Timing chart | 3-58 |
| 3.11 | Grounding | 3-62 |

| | |
|-------------------|---------------------|
| 4. STARTUP | 4- 1 to 4-40 |
|-------------------|---------------------|

| | | |
|-------|--|------|
| 4.1 | Switching power on for the first time..... | 4- 1 |
| 4.1.1 | Startup procedure | 4- 1 |
| 4.1.2 | Wiring check..... | 4- 2 |
| 4.1.3 | Surrounding environment..... | 4- 3 |
| 4.2 | Startup in position control mode | 4- 4 |
| 4.2.1 | Power on and off procedures | 4- 4 |
| 4.2.2 | Stop | 4- 4 |
| 4.2.3 | Test operation | 4- 5 |
| 4.2.4 | Parameter setting..... | 4- 6 |
| 4.2.5 | Actual operation | 4- 6 |
| 4.2.6 | Trouble at start-up..... | 4- 7 |
| 4.3 | Startup in speed control mode..... | 4- 9 |
| 4.3.1 | Power on and off procedures | 4- 9 |
| 4.3.2 | Stop | 4- 9 |
| 4.3.3 | Test operation | 4-10 |
| 4.3.4 | Parameter setting..... | 4-11 |
| 4.3.5 | Actual operation | 4-12 |
| 4.3.6 | Trouble at start-up..... | 4-12 |
| 4.4 | Startup in torque control mode | 4-14 |
| 4.4.1 | Power on and off procedures | 4-14 |
| 4.4.2 | Stop | 4-14 |
| 4.4.3 | Test operation | 4-15 |
| 4.4.4 | Parameter setting..... | 4-16 |
| 4.4.5 | Actual operation | 4-16 |
| 4.4.6 | Trouble at start-up..... | 4-17 |
| 4.5 | Display and operation sections..... | 4-18 |
| 4.5.1 | Summary | 4-18 |
| 4.5.2 | Display flowchart | 4-19 |
| 4.5.3 | Status display mode..... | 4-20 |
| 4.5.4 | Diagnostic mode | 4-24 |
| 4.5.5 | Alarm mode | 4-26 |
| 4.5.6 | Parameter mode | 4-28 |
| 4.5.7 | External I/O signal display..... | 4-31 |
| 4.5.8 | Output signal (DO) forced output..... | 4-34 |
| 4.5.9 | Test operation mode | 4-35 |

| | |
|----------------------|---------------------|
| 5. PARAMETERS | 5- 1 to 5-44 |
|----------------------|---------------------|

| | | |
|-----|---------------------|------|
| 5.1 | Parameter list..... | 5- 1 |
|-----|---------------------|------|

| | | |
|-------|---|------|
| 5.1.1 | Basic setting parameters ([Pr. PA__]) | 5- 1 |
| 5.1.2 | Gain/filter setting parameters ([Pr. PB__]) | 5- 2 |
| 5.1.3 | Extension setting parameters ([Pr. PC__]) | 5- 3 |
| 5.1.4 | I/O setting parameters ([Pr. PD__]) | 5- 5 |
| 5.1.5 | Extension setting 2 parameters ([Pr. PE__]) | 5- 6 |
| 5.1.6 | Extension setting 3 parameters ([Pr. PF__]) | 5- 7 |
| 5.2 | Detailed list of parameters | 5- 8 |
| 5.2.1 | Basic setting parameters ([Pr. PA__]) | 5- 8 |
| 5.2.2 | Gain/filter setting parameters ([Pr. PB__]) | 5-16 |
| 5.2.3 | Extension setting parameters ([Pr. PC__]) | 5-28 |
| 5.2.4 | I/O setting parameters ([Pr. PD__]) | 5-38 |
| 5.2.5 | Extension setting 2 parameters ([Pr. PE__]) | 5-43 |
| 5.2.6 | Extension setting 3 parameters ([Pr. PF__]) | 5-44 |

| | |
|----------------------------------|---------------------|
| 6. NORMAL GAIN ADJUSTMENT | 6- 1 to 6-24 |
|----------------------------------|---------------------|

| | | |
|-------|--|------|
| 6.1 | Different adjustment methods | 6- 1 |
| 6.1.1 | Adjustment on a single servo amplifier | 6- 1 |
| 6.1.2 | Adjustment using MR Configurator2 | 6- 2 |
| 6.2 | One-touch tuning | 6- 3 |
| 6.2.1 | One-touch tuning flowchart | 6- 3 |
| 6.2.2 | Display transition and operation procedure of one-touch tuning | 6- 5 |
| 6.2.3 | Caution for one-touch tuning | 6-13 |
| 6.3 | Auto tuning | 6-14 |
| 6.3.1 | Auto tuning mode | 6-14 |
| 6.3.2 | Auto tuning mode basis | 6-15 |
| 6.3.3 | Adjustment procedure by auto tuning | 6-16 |
| 6.3.4 | Response level setting in auto tuning mode | 6-17 |
| 6.4 | Manual mode | 6-18 |
| 6.5 | 2 gain adjustment mode | 6-22 |

| | |
|--|---------------------|
| 7. SPECIAL ADJUSTMENT FUNCTIONS | 7- 1 to 7-28 |
|--|---------------------|

| | | |
|-------|--|------|
| 7.1 | Filter setting | 7- 1 |
| 7.1.1 | Machine resonance suppression filter | 7- 1 |
| 7.1.2 | Adaptive filter II | 7- 4 |
| 7.1.3 | Shaft resonance suppression filter | 7- 6 |
| 7.1.4 | Low-pass filter | 7- 7 |
| 7.1.5 | Advanced vibration suppression control II | 7- 7 |
| 7.1.6 | Command notch filter | 7-12 |
| 7.2 | Gain switching function | 7-14 |
| 7.2.1 | Applications | 7-14 |
| 7.2.2 | Function block diagram | 7-15 |
| 7.2.3 | Parameter | 7-16 |
| 7.2.4 | Gain switching procedure | 7-19 |
| 7.3 | Tough drive function | 7-22 |
| 7.3.1 | Vibration tough drive function | 7-22 |
| 7.3.2 | Instantaneous power failure tough drive function | 7-24 |

| | |
|---------------------------|---------------------|
| 8. TROUBLESHOOTING | 8- 1 to 8- 6 |
|---------------------------|---------------------|

| | |
|---------------------|--------------|
| 9. OUTLINE DRAWINGS | 9- 1 to 9-10 |
|---------------------|--------------|

| | |
|---------------------------|------|
| 9.1 Servo amplifier | 9- 1 |
| 9.2 Connector | 9- 8 |

| | |
|---------------------|----------------|
| 10. CHARACTERISTICS | 10- 1 to 10- 8 |
|---------------------|----------------|

| | |
|--|-------|
| 10.1 Overload protection characteristics | 10- 1 |
| 10.2 Power supply capacity and generated loss | 10- 3 |
| 10.3 Dynamic brake characteristics..... | 10- 5 |
| 10.3.1 Dynamic brake operation | 10- 5 |
| 10.3.2 Permissible load to motor inertia when the dynamic brake is used..... | 10- 6 |
| 10.4 Cable bending life | 10- 7 |
| 10.5 Inrush currents at power-on of main circuit and control circuit..... | 10- 7 |

| | |
|-------------------------------------|----------------|
| 11. OPTIONS AND AUXILIARY EQUIPMENT | 11- 1 to 11-54 |
|-------------------------------------|----------------|

| | |
|---|-------|
| 11.1 Cable/connector sets | 11- 1 |
| 11.1.1 Combinations of cable/connector sets..... | 11- 2 |
| 11.1.2 MR-D05UDL3M-B STO cable..... | 11- 4 |
| 11.2 Regenerative options..... | 11- 5 |
| 11.2.1 Combination and regenerative power | 11- 5 |
| 11.2.2 Selection of regenerative option | 11- 6 |
| 11.2.3 Parameter setting..... | 11- 8 |
| 11.2.4 Connection of regenerative option | 11- 8 |
| 11.2.5 Dimensions | 11-12 |
| 11.3 FR-BU2 Brake unit..... | 11-14 |
| 11.3.1 Selection..... | 11-14 |
| 11.3.2 Brake unit parameter setting..... | 11-14 |
| 11.3.3 Connection example | 11-15 |
| 11.3.4 Dimensions | 11-20 |
| 11.4 FR-RC Power regenerative converter | 11-21 |
| 11.5 FR-CV Power regenerative common converter | 11-25 |
| 11.6 Junction terminal block MR-TB50..... | 11-30 |
| 11.7 MR Configurator2 | 11-32 |
| 11.8 Battery..... | 11-34 |
| 11.9 Selection example of wires | 11-35 |
| 11.10 Molded case circuit breakers, fuses, magnetic contactors (recommended)..... | 11-37 |
| 11.11 Power factor improving DC reactors..... | 11-37 |
| 11.12 Power factor improving AC reactors..... | 11-39 |
| 11.13 Relays (recommended) | 11-40 |
| 11.14 Noise reduction techniques | 11-41 |
| 11.15 Leakage current breaker | 11-49 |
| 11.16 EMC filter (recommended) | 11-52 |

| | |
|--|----------------|
| 12. ABSOLUTE POSITION DETECTION SYSTEM | 12- 1 to 12-30 |
|--|----------------|

| | |
|---------------------------|-------|
| 12.1 Summary..... | 12- 1 |
| 12.1.1 Features | 12- 1 |
| 12.1.2 Restrictions | 12- 2 |
| 12.2 Specifications..... | 12- 3 |

| | | |
|---------|--|-------|
| 12.3 | Battery replacement procedure | 12- 4 |
| 12.4 | Battery installation and removal procedure | 12- 5 |
| 12.5 | Standard connection example | 12- 7 |
| 12.6 | Signal explanation | 12- 8 |
| 12.7 | Startup procedure | 12- 9 |
| 12.8 | Absolute position data transfer protocol | 12-10 |
| 12.8.1 | Data transfer procedure | 12-10 |
| 12.8.2 | Transfer method | 12-11 |
| 12.8.3 | Home position setting | 12-20 |
| 12.8.4 | Use of servo motor with an electromagnetic brake | 12-22 |
| 12.8.5 | How to process the absolute position data at detection of stroke end | 12-23 |
| 12.9 | Absolute position data transfer errors | 12-23 |
| 12.10 | Communication-based ABS transfer system (available in the future) | 12-25 |
| 12.10.1 | Serial communication command | 12-26 |
| 12.10.2 | Absolute position data transfer protocol | 12-26 |
| 12.11 | Confirmation of absolute position detection data | 12-30 |

| | |
|-------------------------------|-----------------------|
| 13. USING STO FUNCTION | 13- 1 to 13-10 |
|-------------------------------|-----------------------|

| | | |
|--------|--|-------|
| 13.1 | Introduction | 13- 1 |
| 13.1.1 | Summary | 13- 1 |
| 13.1.2 | Terms related to safety | 13- 1 |
| 13.1.3 | Cautions | 13- 1 |
| 13.1.4 | Residual risks of the STO function | 13- 2 |
| 13.1.5 | Specifications | 13- 3 |
| 13.1.6 | Maintenance | 13- 4 |
| 13.2 | STO I/O signal connector (CN8) and signal layouts | 13- 4 |
| 13.2.1 | Signal layouts | 13- 4 |
| 13.2.2 | Signal (device) explanations | 13- 5 |
| 13.2.3 | How to pull out the STO cable | 13- 5 |
| 13.3 | Connection example | 13- 6 |
| 13.3.1 | Connection example for CN8 connector | 13- 6 |
| 13.3.2 | External I/O signal connection example using a MR-J3-D05 safety logic unit | 13- 7 |
| 13.3.3 | External I/O signal connection example using an external safety relay unit | 13- 8 |
| 13.4 | Detailed description of interfaces | 13- 9 |
| 13.4.1 | Sink I/O interface | 13- 9 |
| 13.4.2 | Source I/O interface | 13-10 |

| | |
|-----------------|----------------------------|
| APPENDIX | App.- 1 to App.- 36 |
|-----------------|----------------------------|

| | | |
|--------|--|---------|
| App. 1 | Auxiliary equipment manufacturer (for reference) | App.- 1 |
| App. 2 | Handling of AC servo amplifier batteries for the United Nations Recommendations on the Transport of Dangerous Goods | App.- 1 |
| App. 3 | Symbol for the new EU Battery Directive | App.- 3 |
| App. 4 | Compliance with the CE marking | App.- 3 |
| App. 5 | Compliance with UL/CSA standard | App.- 6 |
| App. 6 | Compliance with KC mark | App.- 9 |
| App. 7 | MR-J3-D05 Safety logic unit | App.-10 |
| App. 8 | EC declaration of conformity | App.-29 |
| App. 9 | Analog monitor | App.-30 |

1 Functions and configuration

1. FUNCTIONS AND CONFIGURATION

1.1 Summary

The Mitsubishi MELSERVO-J4 series general-purpose AC servo has further higher performance and higher functions compared to the previous MELSERVO-J3 series.

MELSERVO-J4 series compatible rotary servo motor is equipped with 22-bit (4194304 pulses/rev) high-resolution absolute encoder. In addition, speed frequency response is increased to 2.5 kHz. Thus, faster and more accurate control is enabled as compared to MELSERVO-J3 series.

The servo amplifier has position, speed, and torque control modes. In the position control mode, the maximum pulse train of 4 Mpps is supported. Further, it can perform operation with the control modes switched, e.g. position/speed control, speed/torque control and torque/position control. Hence, it is applicable to a wide range of fields, not only precision positioning and smooth speed control of machine tools and general industrial machines but also line control and tension control.

With one-touch tuning and real-time auto tuning, you can automatically adjust the servo gains according to the machine.

The tough drive function and the drive recorder function, which are well-received in the MELSERVO-JN series, have been improved. The MR-J4 servo amplifier supports the improved functions. Additionally, the preventive maintenance support function detects an error in the machine parts. This function provides strong support for the machine maintenance and inspection.

The servo amplifier supports the Safe Torque Off (STO) function for safety. By combining with optional MR-J3-D05, the servo amplifier supports Safe stop 1 (SS1) function.

The servo amplifier has a USB communication interface. Therefore, you can connect the servo amplifier to the personal computer with MR Configurator2 installed to perform the parameter setting, test operation, gain adjustment, and others.

1 Functions and configuration

1.2 Function block diagram

The function block diagram of this servo is shown below.

(1) MR-J4-500A or less

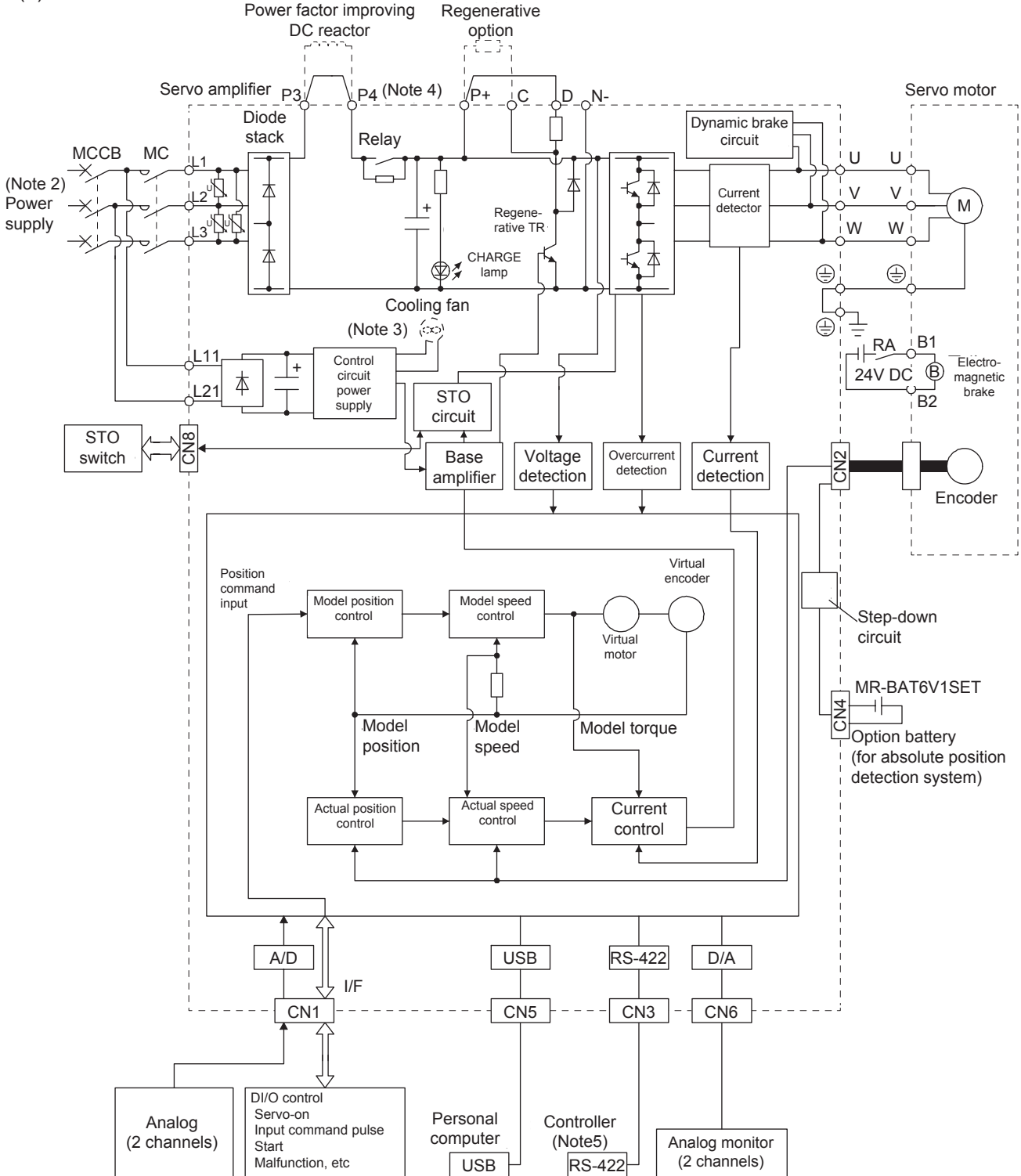

- Note
1. The built-in regenerative resistor is not provided for the MR-J4-10A.
 2. For 1-phase 200 V AC to 240 V AC, connect the power supply to L1 and L3. Leave L2 open. For power supply specifications, refer to section 1.3.
 3. Servo amplifiers MR-J4-70A or greater have a cooling fan.
 4. MR-J4 servo amplifier has P3 and P4 in the upstream of the inrush current suppression circuit. They are different from P1 and P2 of MR-J3 servo amplifiers.
 5. Available in the future.

1 Functions and configuration

(2) MR-J4-700A

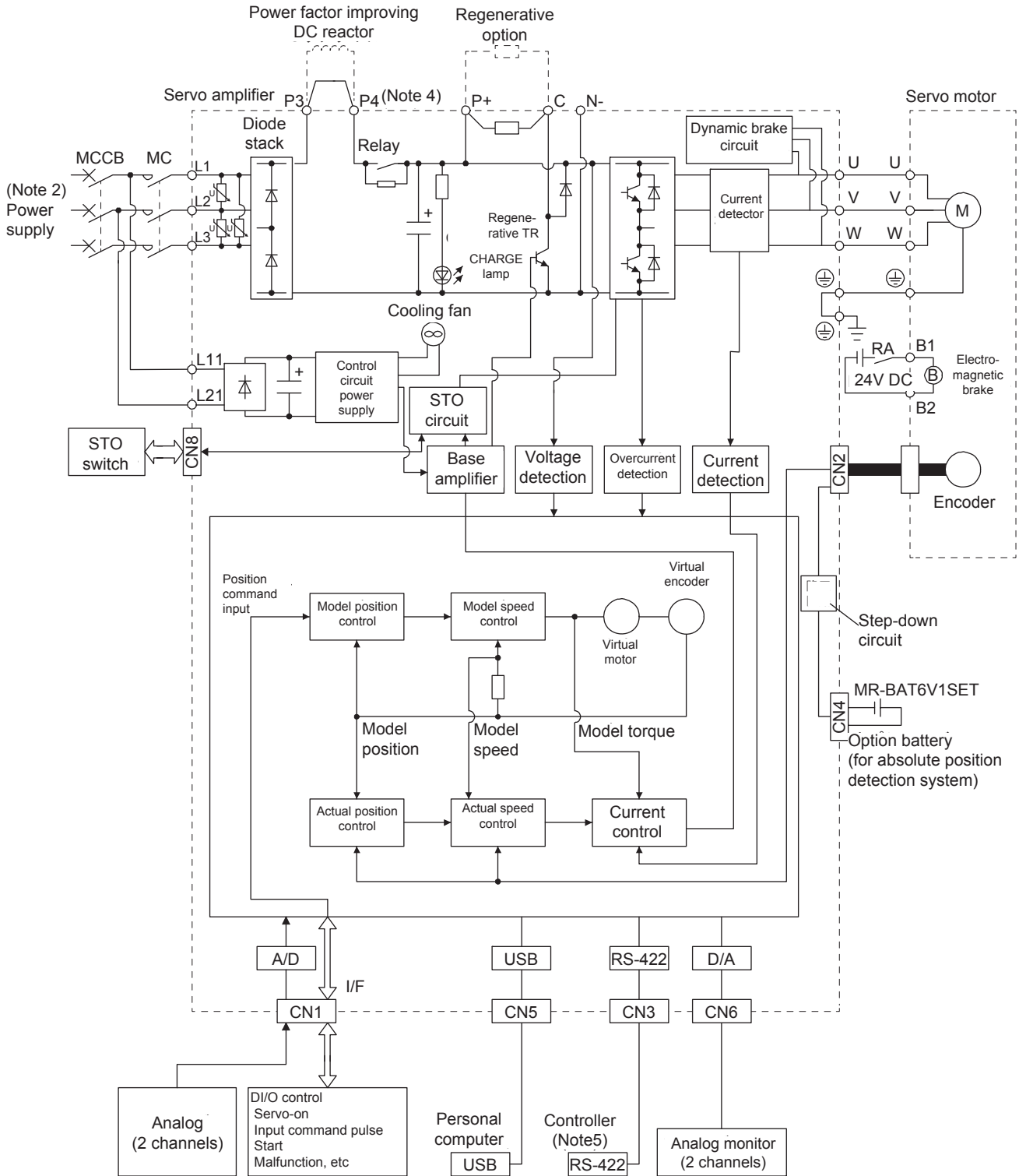

Note 1. For power supply specifications, refer to section 1.3.

Note 2. MR-J4 servo amplifier has P3 and P4 in the upstream of the inrush current suppression circuit. They are different from P1 and P2 of MR-J3 servo amplifiers.

Note 3. Available in the future.

1 Functions and configuration

1.3 Servo amplifier standard specifications

| Model MR-J4- | | 10A | 20A | 40A | 60A | 70A | 100A | 200A | 350A | 500A | 700A | | |
|---------------------------------|---|--|-----|-----|--------------|-----|---|------|------|------|------|--|--|
| Output | Rated voltage | 3-phase 170 V AC | | | | | | | | | | | |
| | Rated current [A] | 1.1 | 1.5 | 2.8 | 3.2 | 5.8 | 6.0 | 11.0 | 17.0 | 28.0 | 37.0 | | |
| Main circuit power supply input | Power supply/Frequency | 3-phase or 1-phase 200 V AC to 240 V AC, 50 Hz /60 Hz | | | | | 3-phase 200 V AC to 240 V AC, 50 Hz/60 Hz | | | | | | |
| | Rated current [A] | 0.9 | 1.5 | 2.6 | 3.2 (Note 5) | 3.8 | 5.0 | 10.5 | 16.0 | 21.7 | 28.9 | | |
| | Permissible voltage fluctuation | 3-phase or 1-phase 170 V AC to 264V AC | | | | | 3-phase 170 V AC to 264V AC | | | | | | |
| | Permissible frequency fluctuation | Within ±5% | | | | | | | | | | | |
| | Power supply capacity [kVA] | Refer to section 10.2. | | | | | | | | | | | |
| | Inrush current [A] | Refer to section 10.5. | | | | | | | | | | | |
| Control circuit power supply | Power supply/Frequency | 1-phase 200 V AC to 240 V AC, 50 Hz/60 Hz | | | | | | | | | | | |
| | Rated current [A] | 0.2 | | | | | | | | 0.3 | | | |
| | Permissible voltage fluctuation | 1-phase 170 V AC to 264V AC | | | | | | | | | | | |
| | Permissible frequency fluctuation | Within ±5% | | | | | | | | | | | |
| | Power consumption [W] | 30 | | | | | | | | 45 | | | |
| | Inrush current [A] | 20 to 30 | | | | | | | | 30 | | | |
| Interface power supply | Voltage/Frequency | 24 V DC ± 10% | | | | | | | | | | | |
| | Power supply capacity [A] | (Note 1) 0.5 (including CN8 connector signals) | | | | | | | | | | | |
| Control method | Sine-wave PWM control, current control method | | | | | | | | | | | | |
| Dynamic brake | Built-in | | | | | | | | | | | | |
| Communication function | USB | Connection to a personal computer or others (MR Configurator2-compatible) | | | | | | | | | | | |
| | RS-422 | Available in the future. | | | | | | | | | | | |
| Position control mode | Max. input pulse frequency | 4 Mpps (for differential receiver), 200 kpps (for open collector) | | | | | | | | | | | |
| | Positioning feedback pulse | Encoder resolution (resolution per servo motor revolution): 22 bits | | | | | | | | | | | |
| | Command pulse multiplying factor | Electronic gear A:1 to 16777216, B:1 to 16777216, 1/10 < A/B < 4000 | | | | | | | | | | | |
| | In-position range setting | 0 pulse to ±65535 pulses (command pulse unit) | | | | | | | | | | | |
| | Error excessive | ±3 revolutions | | | | | | | | | | | |
| | Torque limit | Set by parameter setting or external analog input (0 V DC to +10 V DC/maximum torque) | | | | | | | | | | | |
| Speed control mode | Speed control range | Analog speed command 1: 2000, internal speed command 1: 5000 | | | | | | | | | | | |
| | Analog speed command input | 0 to ±10 V DC/rated speed (The speed at 10 V is changeable with [Pr. PC12].) | | | | | | | | | | | |
| | Speed fluctuation ratio | 0.01% or less (load fluctuation 0% to 100%), 0% (power fluctuation ±10%), ±0.2% or less (ambient temperature 25 ± 10 °C) when using analog speed command | | | | | | | | | | | |
| | Torque limit | Set by parameter setting or external analog input (0 V DC to +10 V DC/maximum torque) | | | | | | | | | | | |
| Torque control mode | Analog torque command input | 0 V DC to ±8 V DC/maximum torque (input impedance 10 kΩ to 12 kΩ) | | | | | | | | | | | |
| | Speed limit | Set by parameter setting or external analog input (0 V DC to 10 V DC/rated speed) | | | | | | | | | | | |

1 Functions and configuration

| Model MR-J4- | | 10A | 20A | 40A | 60A | 70A | 100A | 200A | 350A | 500A | 700A | | |
|-------------------------|------------------------------------|---|--|-----|-----|----------------------------|------|------|------|-------------------------------------|------|--|--|
| Protective functions | | Overcurrent shut-off, regenerative overvoltage shut-off, overload shut-off (electronic thermal), servo motor overheat protection, encoder error protection, regenerative error protection, undervoltage protection, instantaneous power failure protection, overspeed protection, Error excessive warning | | | | | | | | | | | |
| Safety function | | STO (IEC/EN 61800-5-2) | | | | | | | | | | | |
| Safety performance | Standards certified by CB (Note 6) | EN ISO 13849-1 category 3 PL d, EN 61508 SIL 2, EN 62061 SIL CL 2, and EN 61800-5-2 SIL 2 | | | | | | | | | | | |
| | Response performance | 8 ms or less (STO input off → energy shut off) | | | | | | | | | | | |
| | (Note 3) Test pulse input (STO) | Test pulse interval: 1 Hz to 25 Hz Test pulse off time: Up to 1 ms | | | | | | | | | | | |
| Compliance to standards | CE marking | LVD: EN 61800-5-1 EMC: EN 61800-3 MD: EN ISO 13849-1, EN 61800-5-2, EN 62061 | | | | | | | | | | | |
| | UL standard | UL 508C | | | | | | | | | | | |
| Structure (IP rating) | | Natural cooling, open (IP20) | | | | Force cooling, open (IP20) | | | | Force cooling, open (IP20) (Note 4) | | | |
| Close mounting (Note 2) | | Possible | | | | | | | | Impossible | | | |
| Environment | Ambient temperature | Operation | 0 °C to 55 °C (non-freezing) | | | | | | | | | | |
| | | Storage | -20 °C to 65 °C (non-freezing) | | | | | | | | | | |
| | Ambient humidity | Operation | 90% RH or less (non-condensing) | | | | | | | | | | |
| | | Storage | 90% RH or less (non-condensing) | | | | | | | | | | |
| | Ambience | | Indoors (no direct sunlight), free from corrosive gas, flammable gas, oil mist, dust, and dirt | | | | | | | | | | |
| | Altitude | | Max. 1000 m above sea level | | | | | | | | | | |
| Vibration | | 5.9 m/s ² or less at 10 Hz to 55 Hz (directions of X, Y, and Z axes) | | | | | | | | | | | |
| Mass [kg] | | 0.8 | 0.8 | 1.0 | 1.0 | 1.4 | 1.4 | 2.1 | 2.3 | 4.0 | 6.2 | | |

- Note 1. 0.5A is the value applicable when all I/O signals are used. The current capacity can be decreased by reducing the number of I/O points.
2. When closely mounting the servo amplifier of 3.5 kW or less, operate them at the ambient temperatures of 0 °C to 45 °C or at 75% or smaller effective load ratio.
3. This function diagnoses malfunction of contacts including an external circuit by shortly turning off signals from a controller to the servo amplifier at a constant period while input signals of the servo amplifier are on.
4. Except for the terminal block.
5. The rated current is 2.9 A when the servo amplifier is used with UL or CSA compliant servo motor.
6. Available in the future.

1 Functions and configuration

1.4 Combinations of servo amplifiers and servo motors

| Servo amplifier | Rotary servo motor | Linear servo motor (primary side) | Direct drive motor |
|-----------------|---|-----------------------------------|--------------------------|
| MR-J4-10A | HG-KR053, HG-KR13 HG-MR053, HG-MR13 | Available in the future. | Available in the future. |
| MR-J4-20A | HG-KR23 HG-MR23 | | |
| MR-J4-40A | HG-KR43 HG-MR43 | | |
| MR-J4-60A | HG-SR51, HG-SR52 | | |
| MR-J4-70A | HG-KR73 HG-MR73 | | |
| MR-J4-100A | HG-SR81, HG-SR102 | | |
| MR-J4-200A | HG-SR121, HG-SR201, HG-SR152, HG-SR202 | | |
| MR-J4-350A | HG-SR301, HG-SR352 | | |
| MR-J4-500A | HG-SR421, HG-SR502 | | |
| MR-J4-700A | HG-SR702 | | |

1 Functions and configuration

1.5 Function list

The following table lists the functions of this servo. For details of the functions, refer to the reference field.

| Control mode | Description | Detailed explanation |
|---|--|---|
| Position control mode | This servo is used as a position control servo. | Section 3.2.1 Section 3.6.1 Section 4.2 |
| Speed control mode | This servo is used as a speed control servo. | Section 3.2.2 Section 3.6.2 Section 4.3 |
| Torque control mode | This servo is used as a torque control servo. | Section 3.2.3 Section 3.6.3 Section 4.4 |
| Position/speed control change mode | Using input device, control can be switched between position control and speed control. | Section 3.6.4 |
| Speed/torque control change mode | Using input device, control can be switched between speed control and torque control. | Section 3.6.5 |
| Torque/position control change mode | Using input device, control can be switched between torque control and position control. | Section 3.6.6 |
| High-resolution encoder | High-resolution encoder of 4194304 pulses/rev is used as the encoder of the rotary servo motor compatible with the MELSERVO-J4 series. | |
| Absolute position detection system | Merely setting a home position once makes home position return unnecessary at every power-on. | Chapter 12 |
| Gain switching function | You can switch between gains during rotation and gains during stop or can use an input device to switch gains during operation. | Section 7.2 |
| Advanced vibration suppression control II | This function suppresses vibration at the arm end or residual vibration. | Section 7.1.5 |
| Adaptive filter II | Servo amplifier detects mechanical resonance and sets filter characteristics automatically to suppress mechanical vibration. | Section 7.1.2 |
| Low-pass filter | Suppresses high-frequency resonance which occurs as servo system response is increased. | Section 7.1.4 |
| Machine analyzer function | Analyzes the frequency characteristic of the mechanical system by simply connecting a MR Configurator2 installed personal computer and servo amplifier. MR Configurator2 is necessary for this function. | |
| Robust filter | This function provides better disturbance response in case low response level that load to motor inertia ratio is high for such as roll send axes. | [Pr. PE41] |
| Slight vibration suppression control | Suppresses vibration of ± 1 pulse produced at a servo motor stop. | [Pr. PB24] |
| Electronic gear | Input pulses can be multiplied by 1/10 to 4000. | [Pr. PA06] [Pr. PA07] |
| S-pattern acceleration/deceleration time constant | Speed can be increased and decreased smoothly. | [Pr. PC03] |
| Auto tuning | Automatically adjusts the gain to optimum value if load applied to the servo motor shaft varies. Higher in performance than MR-J3 series servo amplifier. | Section 6.3 |
| Brake unit | Used when the regenerative option cannot provide enough regenerative power. Can be used for the 5 kW or more servo amplifier. | Section 11.3 |
| Power regenerative converter | Used when the regenerative option cannot provide enough regenerative power. Can be used for the 5 kW or more servo amplifier. | Section 11.4 |
| Regenerative option | Used when the built-in regenerative resistor of the servo amplifier does not have sufficient regenerative capability for the regenerative power generated. | Section 11.2 |
| Alarm history clear | Alarm history is cleared. | [Pr. PC18] |
| Output signal selection (device settings) | ST1 (Forward rotation start), ST2 (Reverse rotation start), and SON (Servo-on) and other input device can be assigned to any pins. | [Pr. PD03] to [Pr. PD22] |
| Output signal selection (device settings) | The pins that output the output devices, including ALM (Malfunction) and DB (Dynamic brake interlock), can be assigned to certain pins of the CN1 connectors. | [Pr. PD23] to [Pr. PD28] |
| Output signal (DO) forced output | Output signal can be forced on/off independently of the servo status. This function is used for wiring check of output signal. | Section 4.5.8 |
| Restart after instantaneous power failure | If the input power supply voltage had reduced to cause an alarm but has returned to normal, the servo motor can be restarted by merely switching on the start signal. (Available in the future.) | |

1 Functions and configuration

| Function | Description | Detailed explanation |
|--|--|---|
| Command pulse selection | Command pulse train form can be selected from among three different types. | [Pr. PA13] |
| Torque limit | Servo motor torque can be limited to any value. | Section 3.6.1 (5) [Pr. PA11] [Pr. PA12] |
| Speed limit | Servo motor speed can be limited to any value. | Section 3.6.3 (3) [Pr. PC05] to [Pr. PC11] |
| Status display | Servo status is shown on the 5-digit, 7-segment LED display | Section 4.5 |
| External I/O signal display | On/off statuses of external I/O signals are shown on the display. | Section 4.5.7 |
| Automatic VC offset | Voltage is automatically offset to stop the servo motor if it does not come to a stop when VC (Analog speed command) or VLA (Analog speed limit is 0 V). | Section 4.5.4 |
| Alarm code output | If an alarm has occurred, the corresponding alarm number is output in 3-bit code. | Chapter 8 |
| Test operation mode | Jog operation, positioning operation, motor-less operation, DO forced output, and program operation MR Configurator2 is required to perform positioning operation and program operation. | Section 4.5.9 |
| Analog monitor output | Servo status is output in terms of voltage in real time. | [Pr. PC14], [Pr. PC15] |
| MR Configurator2 | Using a personal computer, you can perform the parameter setting, test operation, monitoring, and others. | Section 11.7 |
| One-touch tuning | Gain adjustment is performed just by one click on a certain button on MR Configurator2 or operation section. MR Configurator2 is necessary for this function. | Section 6.1 |
| Tough drive function | This function makes the equipment continue operating even under the condition that an alarm occurs. The tough drive function includes two types: the vibration tough drive and the instantaneous power failure tough drive. | Section 7.3 |
| Drive recorder function | This function continuously monitors the servo status and records the status transition before and after an alarm for a fixed period of time. You can check the recorded data on the drive recorder window on MR Configurator2 by clicking the "Graph" button. However, the drive recorder will not operate on the following conditions. 1. You are using the graph function of MR Configurator2. 2. You are using the machine analyzer function. 3. [Pr. PF21] is set to "-1". | [Pr. PA23] |
| STO function | This function is a safety function that complies with IEC/EN 61800-5-2. You can create a safety system for the equipment easily. | Chapter 13 |
| Servo amplifier life diagnostic function | You can check the cumulative energization time and the number of on/off times of the inrush relay. This function gives an indication of the replacement time for parts of the servo amplifier including a capacitor and a relay before they malfunction. MR Configurator2 is necessary for this function. | |
| Power monitoring function | This function calculates the power running energy and the regenerative power from the data in the servo amplifier such as speed and current. Power consumption and others are displayed on MR Configurator2. | |
| Machine diagnosis function | From the data in the servo amplifier, this function estimates the friction and vibrational component of the drive system in the equipment and recognizes an error in the machine parts, including a ball screw and bearing. MR Configurator2 is necessary for this function. | |

1 Functions and configuration

1.6 Model designation

(1) Rating plate

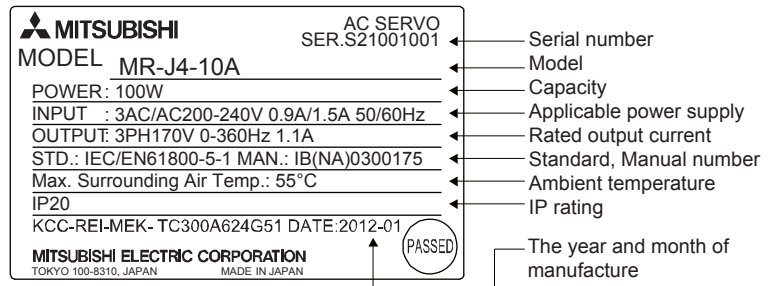

(2) Model

The following describes what each block of a model name indicates.

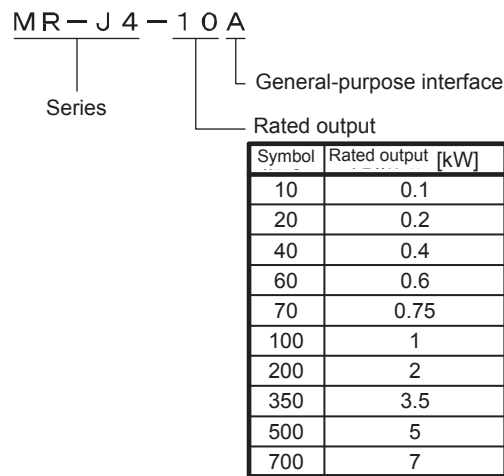

1 Functions and configuration

1.7 Structure

1.7.1 Parts identification

(1) MR-J4-200A or less

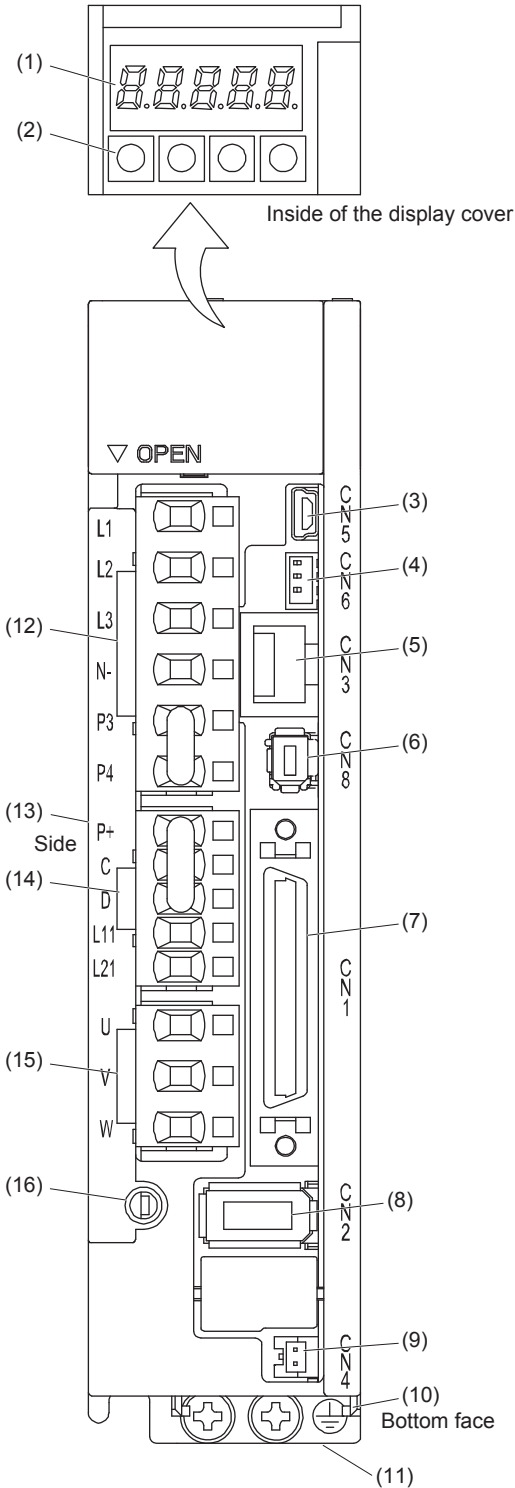

| No. | Name/Application | Detailed explanation |
|------|---|----------------------------|
| (1) | Display The 5-digit, seven-segment LED shows the servo status and the alarm number. | Section 4.5 |
| (2) | Operation section Used to perform status display, diagnostic, alarm, and parameter setting operations. | Section 4.5 |
| (3) | USB communication connector (CN5) Connect with the personal computer. | Section 11.7 |
| (4) | Analog monitor connector (CN6) Outputs the analog monitor. | Section 3.2 |
| (5) | RS-422 communication connector (CN3) Connect with the personal computer, etc. | Chapter 14 |
| (6) | STO input signal connector (CN8) Used to connect MR-J3-D05 safety logic unit and external safety relay. | Chapter 13 |
| (7) | I/O signal connector (CN1) Used to connect digital I/O signals. | Section 3.2 Section 3.4 |
| (8) | Encoder connector (CN2) Used to connect the servo motor encoder. | Section 3.4 |
| (9) | Battery connector (CN4) Used to connect the battery for absolute position data backup. | Chapter 12 |
| (10) | Battery holder Install the the battery for absolute position data backup. | Section 12.4 |
| (11) | Protective earth (PE) terminal Ground terminal. | Section 3.1 |
| (12) | Main circuit power supply connector (CNP1) Connect the input power supply. | Section 3.3 |
| (13) | Rating plate | Section 1.6 |
| (14) | Control circuit power supply connector (CNP2) Connect the control circuit power supply or regenerative option. | Section 3.1 |
| (15) | Servo motor power supply connector (CNP3) Connect the servo motor. | Section 3.3 |
| (16) | Charge lamp Lit to indicate that the main circuit is charged. While this lamp is lit, do not reconnect the cables. | |

Note. The illustration above is of MR-J4-10A.

1 Functions and configuration

(2) MR-J4-350A

The broken line area is the same as MR-J4-200A or less.

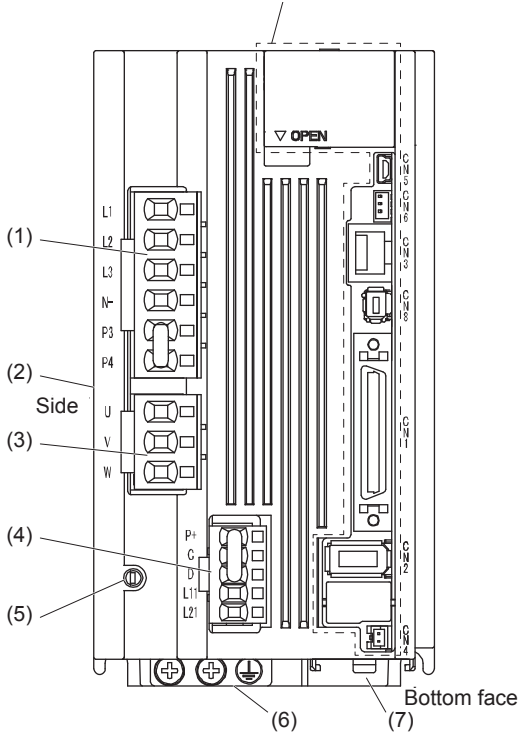

| No. | Name/Application | Detailed explanation |
|-----|---|----------------------------|
| (1) | Main circuit power supply connector (CNP1) Connect the input power supply. | Section 3.1 Section 3.3 |
| (2) | Rating plate | Section 1.6 |
| (3) | Servo motor power supply connector (CNP3) Connect the servo motor. | Section 3.1 |
| (4) | Control circuit power supply connector (CNP2) Connect the control circuit power supply or regenerative option. | Section 3.3 |
| (5) | Charge lamp Lit to indicate that the main circuit is charged. While this lamp is lit, do not reconnect the cables. | |
| (6) | Protective earth (PE) terminal Ground terminal. | Section 3.1 Section 3.3 |
| (7) | Battery holder Install the the battery for absolute position data backup. | Section 12.4 |

1 Functions and configuration

(3) MR-J4-500A

POINT

● The servo amplifier is shown with the front cover open. The front cover cannot be removed.

The broken line area is the same as MR-J4-200A or less.

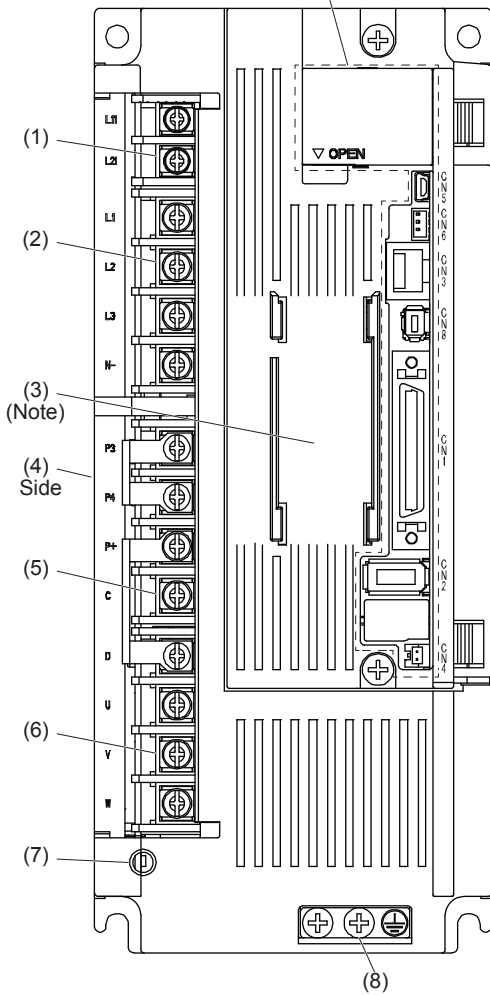

| No. | Name/Application | Detailed explanation |
|-----|--|----------------------------|
| (1) | Control circuit terminal block (TE2) Used to connect the control circuit power supply. | Section 3.1 |
| (2) | Main circuit terminal block (TE1) Connect the input power supply. | Section 3.3 |
| (3) | Battery holder Install the the battery for absolute position data backup. | Section 12.4 |
| (4) | Rating plate | Section 1.6 |
| (5) | Regenerative option/power factor improving reactor terminal block (TE3) Used to connect regenerative options and a power factor improving DC reactor. | Section 3.1 Section 3.3 |
| (6) | Servo motor power supply terminal block (TE4) Connect the servo motor. | |
| (7) | Charge lamp Lit to indicate that the main circuit is charged. While this lamp is lit, do not reconnect the cables. | |
| (8) | Protective earth (PE) terminal Ground terminal. | Section 3.1 Section 3.3 |

Note. Lines around the battery holder are omitted from the illustration.

1 Functions and configuration

(4) MR-J4-700A

| POINT |
|--|
| <p>● The servo amplifier is shown without the front cover. For removal of the front cover, refer to section 1.6.2.</p> |

The broken line area is the same as MR-J4-200A or less.

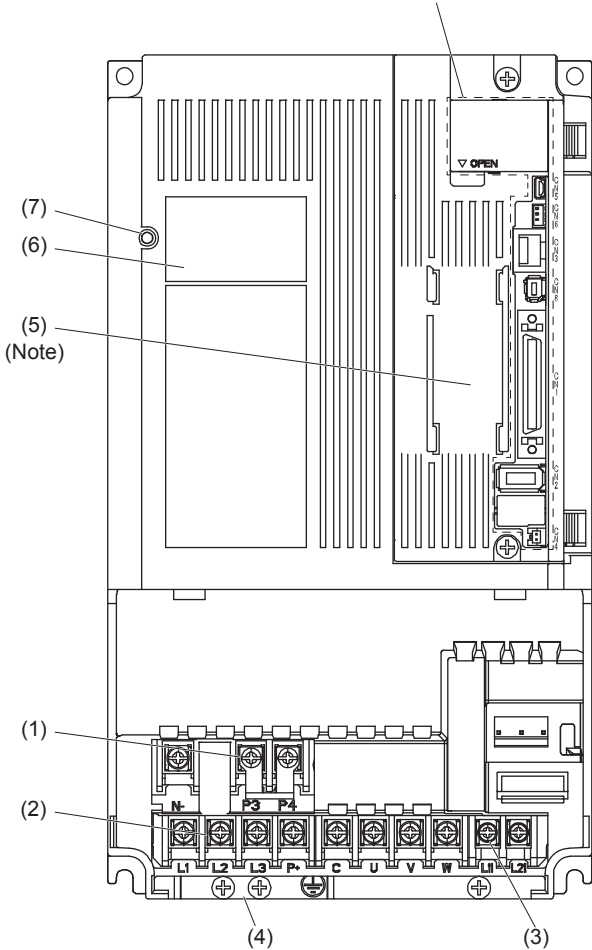

| No. | Name/Application | Detailed explanation |
|-----|---|----------------------------|
| (1) | Power factor improving reactor terminal block (TE3) Used to connect the DC reactor. | Section 3.1 Section 3.3 |
| (2) | Main circuit terminal block (TE1) Used to connect the input power supply, regenerative option, and servo motor. | |
| (3) | Control circuit terminal block (TE2) Used to connect the control circuit power supply. | |
| (4) | Protective earth (PE) terminal Ground terminal. | |
| (5) | Battery holder Install the the battery for absolute position data backup. | Section 12.4 |
| (6) | Rating plate | Section 1.6 |
| (7) | Charge lamp Lit to indicate that the main circuit is charged. While this lamp is lit, do not reconnect the cables. | |

Note. Lines around the battery holder are omitted from the illustration.

1 Functions and configuration

1.7.2 Removal and reinstallation of the front cover



Cautions

- Before removing or installing the front cover, turn off the power and wait for 15 minutes or more until the charge lamp turns off. Then, confirm that the voltage between P+ and N- is safe with a voltage tester and others. Otherwise, an electric shock may occur. In addition, when confirming whether the charge lamp is off or not, always confirm it from the front of the servo amplifier.

(1) For MR-J4-700A

Removal of the front cover

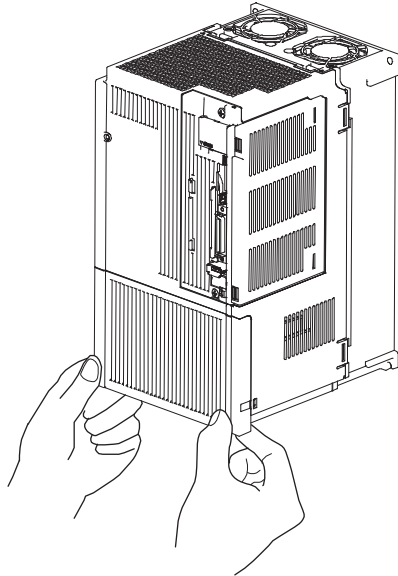

- 1) Hold the ends of lower side of the front cover with both hands.

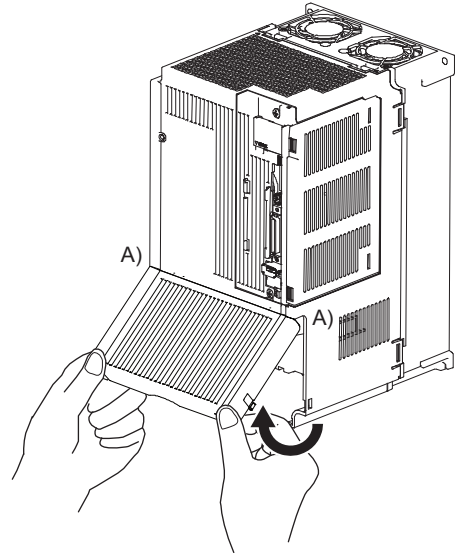

- 2) Pull up the cover, supporting at point A).

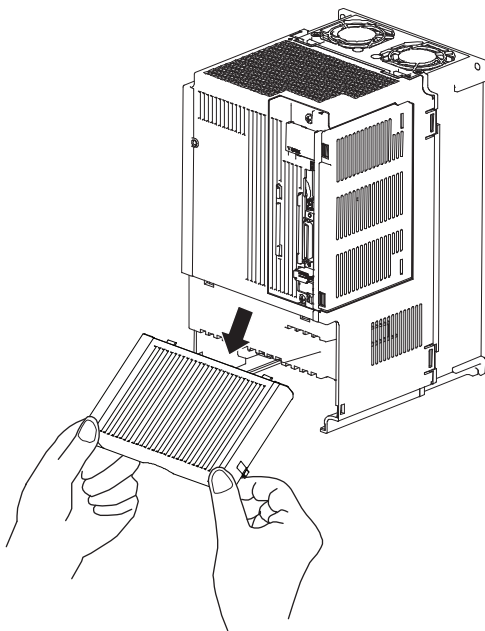

- 3) Pull out the front cover to remove. Hold the ends of lower side of the front cover with both hands.

1 Functions and configuration

Reinstallation of the front cover

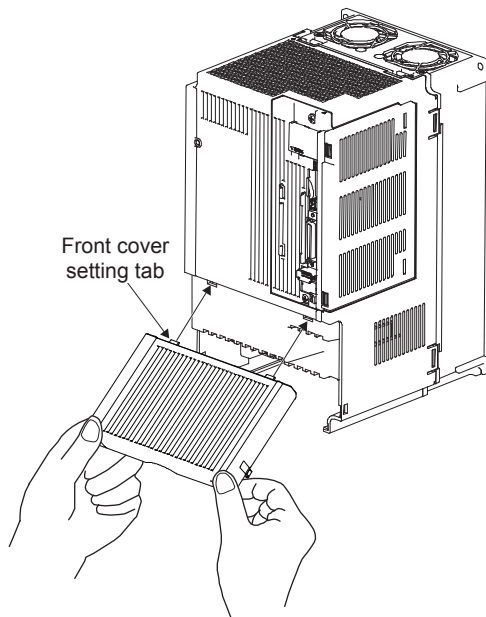

1) Insert the front cover setting tabs into the sockets of servo amplifier (2 places).

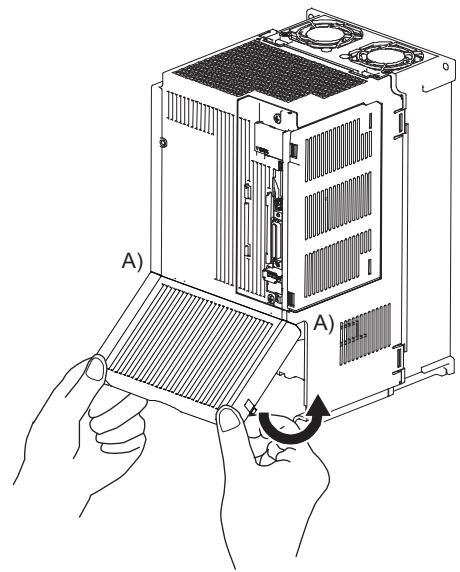

2) Push down the cover, supporting at point A).

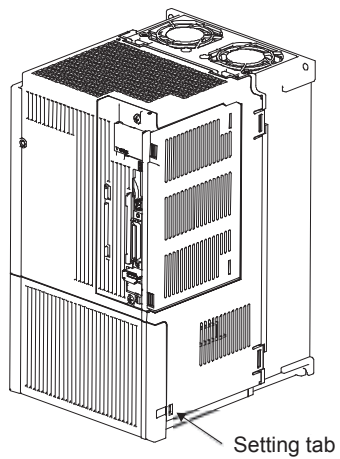

3) Press the cover against the terminal box until the installing knobs click.

1 Functions and configuration

1.8 Configuration including auxiliary equipment

POINT

● Equipment other than the servo amplifier and servo motor are optional or recommended products.

(1) MR-J4-200A or less

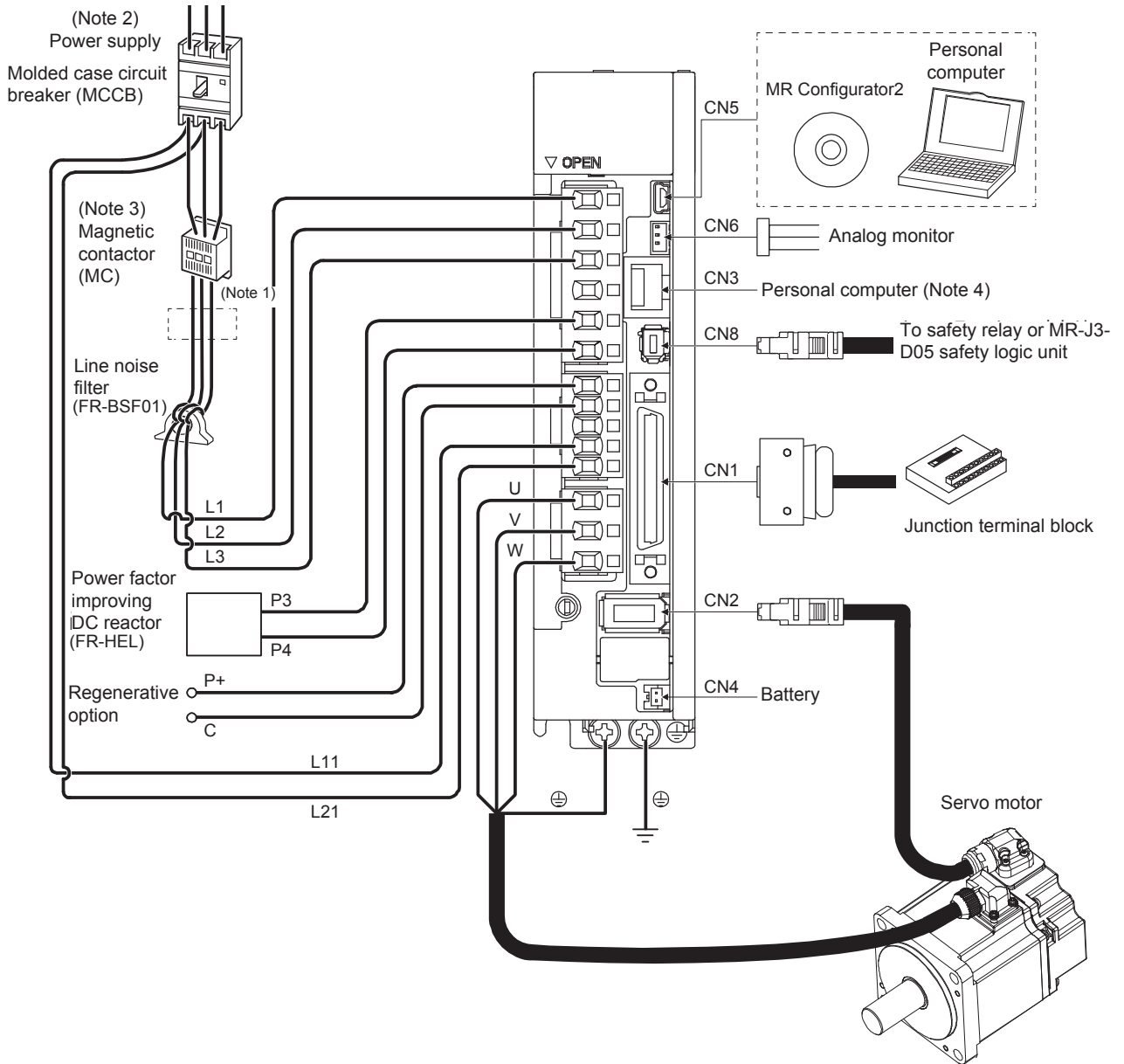

- Note 1. The power factor improving AC reactor can also be used. In this case, the power factor improving DC reactor cannot be used. When not using the power factor improving DC reactor, short P3 and P4.
- Note 2. A 1-phase 200 V AC to 240 V AC power supply may be used with the servo amplifier of MR-J3-70A or less. For 1-phase 200 V AC to 240 V AC, connect the power supply to L1 and L3. Leave L2 open. For power supply specifications, refer to section 1.3.
- Note 3. Depending on the main circuit voltage and operation pattern, bus voltage decreases, and that may cause the forced stop deceleration to shift to the dynamic brake deceleration. When dynamic brake deceleration is not required, slow the time to turn off the magnetic contactor.
- Note 4. RS-422 communication function will be available in the future.

1 Functions and configuration

(2) MR-J4-350A

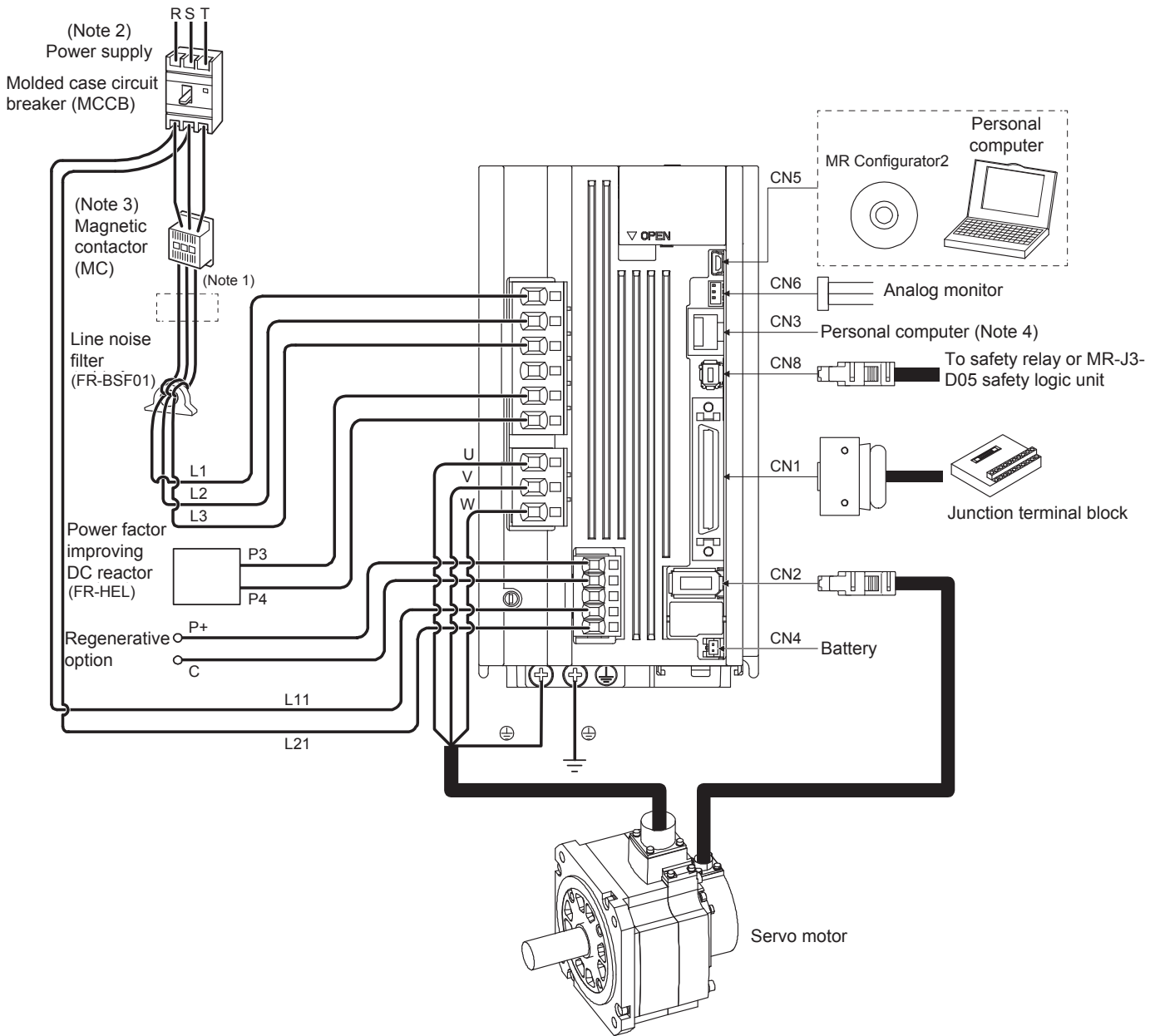

- Note 1. The power factor improving AC reactor can also be used. In this case, the power factor improving DC reactor cannot be used. When not using the power factor improving DC reactor, short P3 and P4.
- Note 2. For power supply specifications, refer to section 1.3.
- Note 3. Depending on the main circuit voltage and operation pattern, bus voltage decreases, and that may cause the forced stop deceleration to shift to the dynamic brake deceleration. When dynamic brake deceleration is not required, slow the time to turn off the magnetic contactor.
- Note 4. RS-422 communication function will be available in the future.

1 Functions and configuration

(3) MR-J4-500A

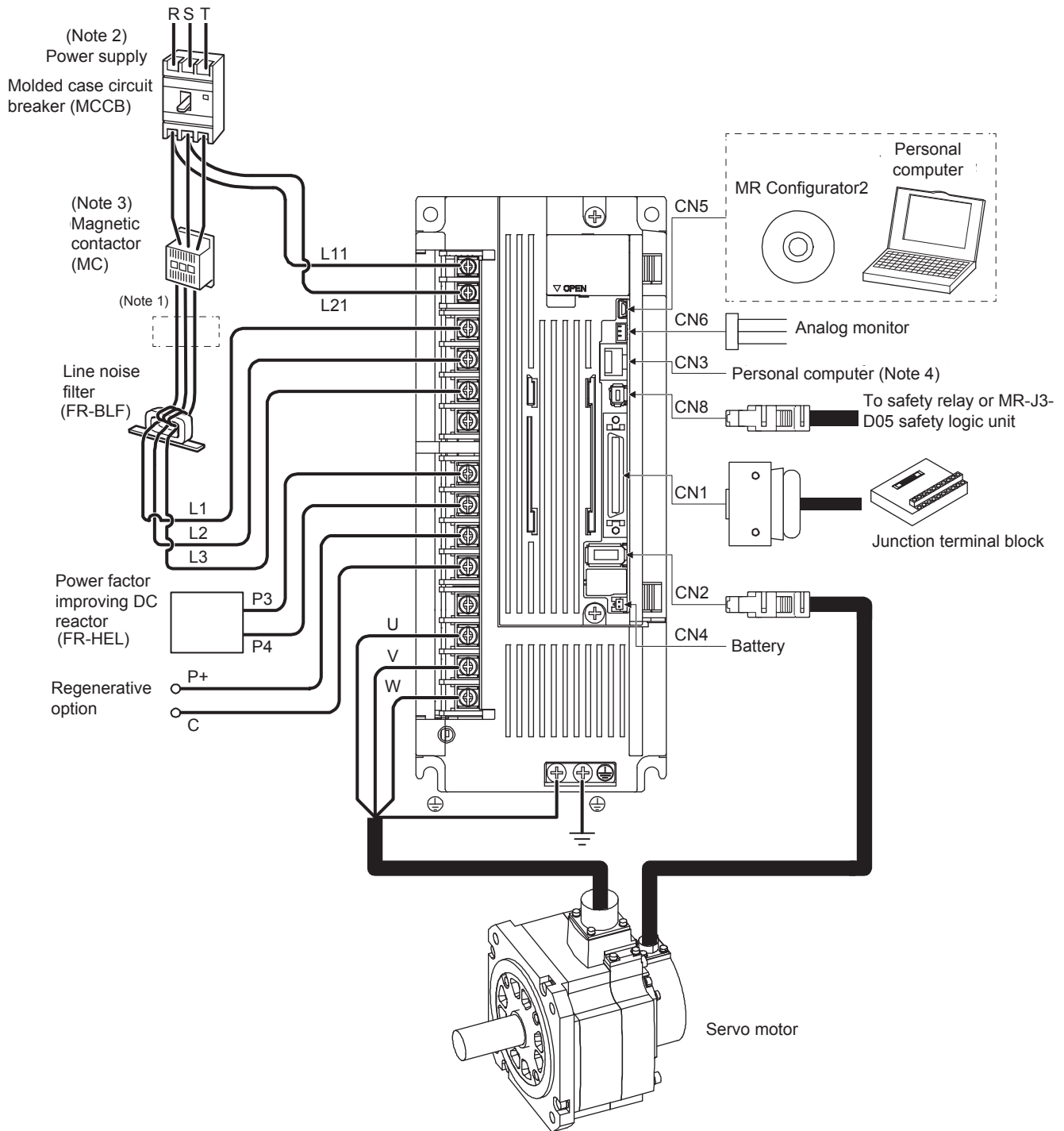

- Note 1. The power factor improving AC reactor can also be used. In this case, the power factor improving DC reactor cannot be used. When not using the power factor improving DC reactor, short P3 and P4.
- Note 2. For power supply specifications, refer to section 1.3.
- Note 3. Depending on the main circuit voltage and operation pattern, bus voltage decreases, and that may cause the forced stop deceleration to shift to the dynamic brake deceleration. When dynamic brake deceleration is not required, slow the time to turn off the magnetic contactor.
- Note 4. RS-422 communication function will be available in the future.

1 Functions and configuration

(4) MR-J4-700A

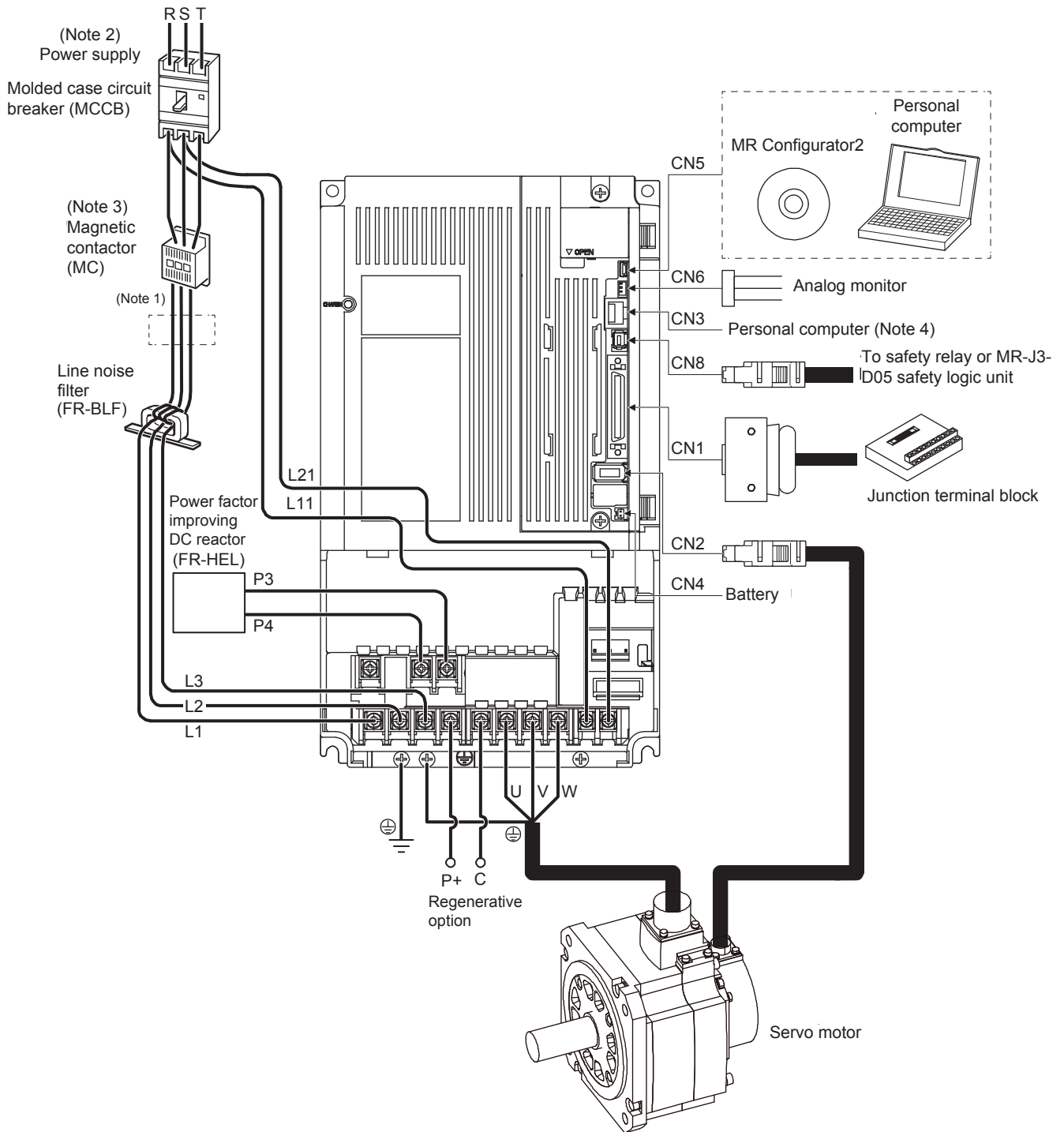

- Note 1. The power factor improving AC reactor can also be used. In this case, the power factor improving DC reactor cannot be used. When not using the power factor improving DC reactor, short P3 and P4.
- Note 2. For power supply specifications, refer to section 1.3.
- Note 3. Depending on the main circuit voltage and operation pattern, bus voltage decreases, and that may cause the forced stop deceleration to shift to the dynamic brake deceleration. When dynamic brake deceleration is not required, slow the time to turn off the magnetic contactor.
- Note 4. RS-422 communication function will be available in the future.

2. INSTALLATION

2. INSTALLATION



WARNING ● To prevent electric shock, ground each equipment securely.



CAUTION

- Stacking in excess of the specified number of product packages is not allowed.
- Install the equipment on incombustible material. Installing it directly or close to combustibles will lead to a fire.
- Install the servo amplifier and the servo motor in a load-bearing place in accordance with the Instruction Manual.
- Do not get on or put heavy load on the equipment. Otherwise, it may cause injury.
- Use the equipment within the specified environment. For the environment, refer to section 1.3.
- Provide an adequate protection to prevent screws and other conductive matter, oil and other combustible matter from entering the servo amplifier.
- Do not block the intake and exhaust areas of the servo amplifier. Otherwise, it may cause a malfunction.
- Do not drop or strike the servo amplifier. Isolate it from all impact loads.
- Do not install or operate the servo amplifier which have been damaged or have any parts missing.
- When the equipment has been stored for an extended period of time, contact your local sales office.
- When handling the servo amplifier, be careful about the edged parts such as corners of the servo amplifier.
- The servo amplifier must be installed in the metal cabinet.

POINT

- When pulling out CNP1, CNP2, and CNP3 connectors of MR-J4-60A or less servo amplifiers, pull out CN3 and CN8 connectors beforehand.

2. INSTALLATION

2.1 Installation direction and clearances

| | |
|--|---|
|  CAUTION | ● The equipment must be installed in the specified direction. Otherwise, it may cause a malfunction. |
| | ● Leave specified clearances between the servo amplifier and the cabinet walls or other equipment. Otherwise, it may cause a malfunction. |

(1) 7 kW or less

(a) Installation of one servo amplifier

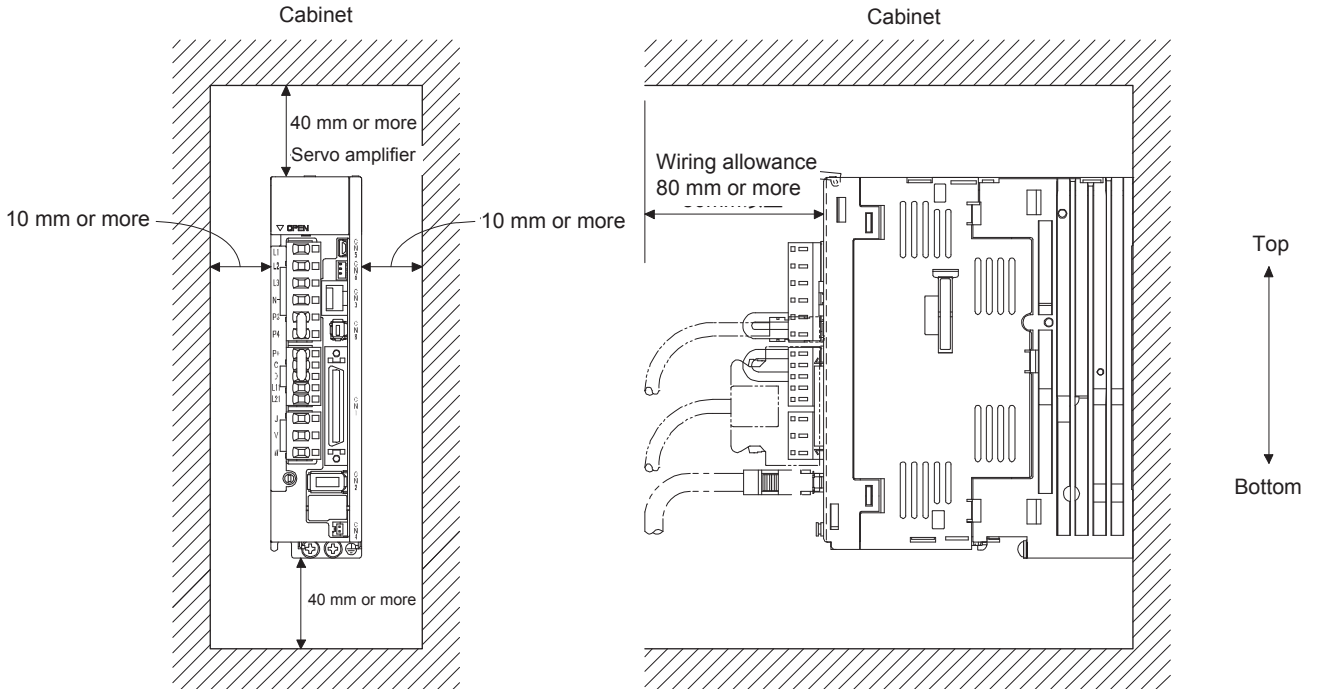

2. INSTALLATION

(b) Installation of two or more servo amplifiers

| POINT |
|--|
| <ul style="list-style-type: none"> ● Close mounting is possible depending on the capacity of the servo amplifier. Refer to section 1.3 for availability of close mounting. ● When mounting the servo amplifiers closely, do not install the servo amplifier whose depth is larger than that of the left side servo amplifier since CNP1, CNP2, and CNP3 connectors cannot be disconnected. |

Leave a large clearance between the top of the servo amplifier and the cabinet walls, and install a cooling fan to prevent the internal temperature of the cabinet from exceeding the environment. When mounting the servo amplifiers closely, leave a clearance of 1 mm between the adjacent servo amplifiers in consideration of mounting tolerances. In this case, keep the ambient temperature within 0 °C to 45 °C or use the servo amplifier with 75% or less of the effective load ratio.

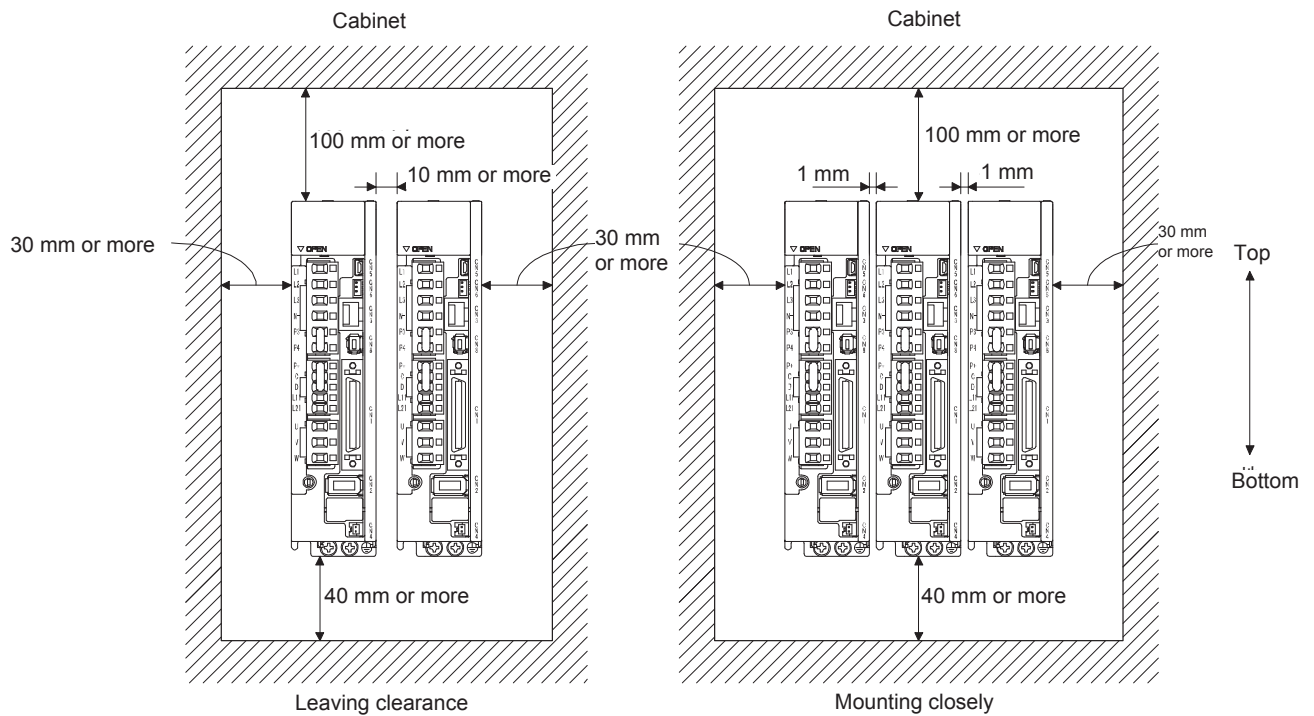

(2) Others

When using heat generating equipment such as the regenerative option, install them with full consideration of heat generation so that the servo amplifier is not affected. Install the servo amplifier on a perpendicular wall in the correct vertical direction.

2.2 Keep out foreign materials

- (1) When drilling in the cabinet, prevent drill chips and wire fragments from entering the servo amplifier.
- (2) Prevent oil, water, metallic dust, etc. from entering the servo amplifier through openings in the cabinet or a cooling fan installed on the ceiling.
- (3) When installing the cabinet in a place where toxic gas, dirt and dust exist, conduct an air purge (force clean air into the cabinet from outside to make the internal pressure higher than the external pressure) to prevent such materials from entering the cabinet.

2. INSTALLATION

2.3 Encoder cable stress

- (1) The way of clamping the cable must be fully examined so that bending stress and cable's own weight stress are not applied to the cable connection.
- (2) For use in any application where the servo motor moves, fix the cables (encoder, power supply, and brake) with having some slack from the connector connection part of the servo motor to avoid putting stress on the connector connection part. Use the optional encoder cable within the bending life range. Use the power supply and brake wiring cables within the bending life of the cables.
- (3) Avoid any probability that the cable sheath might be cut by sharp chips, rubbed by a machine corner or stamped by workers or vehicles.
- (4) For installation on a machine where the servo motor moves, the flexing radius should be made as large as possible. Refer to section 10.4 for the bending life.

2.4 Inspection items

| | |
|---|--|
|  WARNING | <ul style="list-style-type: none">● Before starting maintenance and/or inspection, turn off the power and wait for 15 minutes or more until the charge lamp turns off. Then, confirm that the voltage between P+ and N- is safe with a voltage tester and others. Otherwise, an electric shock may occur. In addition, when confirming whether the charge lamp is off or not, always confirm it from the front of the servo amplifier.● To avoid an electric shock, only qualified personnel should attempt inspections. For repair and parts replacement, contact your local sales office. |
|---|--|

| |
|---|
| POINT |
| <ul style="list-style-type: none">● Do not perform insulation resistance test on the servo amplifier. Otherwise, it may cause a malfunction.● Do not disassemble and/or repair the equipment on customer side. |

It is recommended that the following points periodically be checked.

- (1) Check for loose terminal block screws. Retighten any loose screws.
- (2) Check the cables and the like for scratches or cracks. Inspect them periodically according to operating conditions especially when the servo motor is movable.
- (3) Check that the connector is securely connected to the servo amplifier.
- (4) Check that the wires are not coming out from the connector.
- (5) Check for dust accumulation on the servo amplifier.
- (6) Check for unusual noise generated from the servo amplifier.

2. INSTALLATION

2.5 Parts having service lives

Service lives of the following parts are listed below. However, the service life vary depending or operating methods and environment. If any fault is found in the parts, they must be replaced immediately regardless of their service lives. For parts replacement, please contact your sales representative.

| Part name | Life guideline |
|---------------------------|--|
| Smoothing capacitor | 10 years |
| Relay | Number of power-on times: 100,000 times Number of on and off for STO: 1,000,000 times |
| Cooling fan | 10,000 hours to 30,000 hours (2 years to 3 years) |
| Absolute position battery | Refer to section 12.2. |

(1) Smoothing capacitor

The characteristic of smoothing capacitor is deteriorated due to ripple currents, etc. The life of the capacitor greatly depends on ambient temperature and operating conditions. The capacitor will reach the end of its life in 10 years of continuous operation in normal air-conditioned environment (40 °C surrounding air temperature or less).

(2) Relays

Contact faults will occur due to contact wear arisen from switching currents. Relays reach the end of their lives when the power has been turned on 100,000 times, or when the STO has been turned on and off 1,000,000 times while the servo motor is stopped under servo-off state. However, the lives of relays may depend on the power supply capacity.

(3) Servo amplifier cooling fan

The cooling fan bearings reach the end of their life in 10,000 hours to 30,000 hours. Normally, therefore, the cooling fan must be replaced in a few years of continuous operation as a guideline. It must also be changed if unusual noise or vibration is found during inspection.

The life indicates under the yearly average ambient temperature of 40 °C, free from corrosive gas, flammable gas, oil mist, dust and dirt.

3. SIGNALS AND WIRING

3. SIGNALS AND WIRING



WARNING

- Any person who is involved in wiring should be fully competent to do the work.
- Before wiring, turn off the power and wait for 15 minutes or more until the charge lamp turns off. Then, confirm that the voltage between P+ and N- is safe with a voltage tester and others. Otherwise, an electric shock may occur. In addition, when confirming whether the charge lamp is off or not, always confirm it from the front of the servo amplifier.
- Ground the servo amplifier and servo motor securely.
- Do not attempt to wire the servo amplifier and servo motor until they have been installed. Otherwise, it may cause an electric shock.
- The cables should not be damaged, stressed, loaded, or pinched. Otherwise, it may cause an electric shock.
- To avoid an electric shock, insulate the connections of the power supply terminals.



Cautions

- Wire the equipment correctly and securely. Otherwise, the servo motor may operate unexpectedly, resulting in injury.
- Connect cables to the correct terminals. Otherwise, a burst, damage, etc. may occur.
- Ensure that polarity (+/-) is correct. Otherwise, a burst, damage, etc. may occur.
- The surge absorbing diode installed to the DC relay for control output should be fitted in the specified direction. Otherwise, the emergency stop and other protective circuits may not operate.

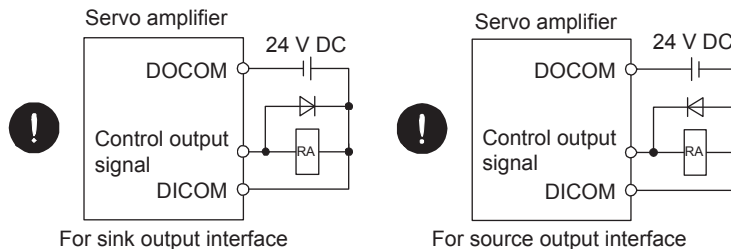

- Use a noise filter, etc. to minimize the influence of electromagnetic interference. Electromagnetic interference may be given to the electronic equipment used near the servo amplifier.
- Do not install a power capacitor, surge killer or radio noise filter (FR-BIF option) with the power line of the servo motor.
- When using the regenerative resistor, switch power off with the alarm signal. Otherwise, a transistor fault or the like may overheat the regenerative resistor, causing a fire.
- Do not modify the equipment.

3. SIGNALS AND WIRING

! Cautions

- Connect the servo amplifier power output (U, V, and W) to the servo motor power input (U, V, and W) directly. Do not let a magnetic contactor, etc. intervene. Otherwise, it may cause a malfunction.

3.1 Input power supply circuit

! Cautions

- Always connect a magnetic contactor between the power supply and the main circuit power supply (L1, L2, and L3) of the servo amplifier, in order to configure a circuit that shuts down the power supply on the side of the servo amplifier's power supply. If a magnetic contactor is not connected, continuous flow of a large current may cause a fire when the servo amplifier malfunctions.
- Use ALM (Malfunction) to switch main circuit power supply off. Not doing so may cause a fire when a regenerative transistor malfunctions or the like may overheat the regenerative resistor.
- Check the servo amplifier model, and then input proper voltage to the servo amplifier power supply. If input voltage exceeds the upper limit, the servo amplifier will break down.

| POINT |
|--|
| <ul style="list-style-type: none"> ● EM2 has the same function as EM1 in the torque control mode. ● Connect the 1-phase 200 V AC to 240 V AC power supply to L1 and L3. One of the connecting destinations is different from MR-J3 Series Servo Amplifier. When using MR-J4 as a replacement for MR-J3, be careful not to connect the power to L2. |

Wire the power supply and main circuit so that the servo-on command turned off as soon as an alarm occurs and the power supply is shut off.

3. SIGNALS AND WIRING

(1) For 3-phase 200 V AC to 240 V AC power supply of MR-J4-10A to MR-J4-350A

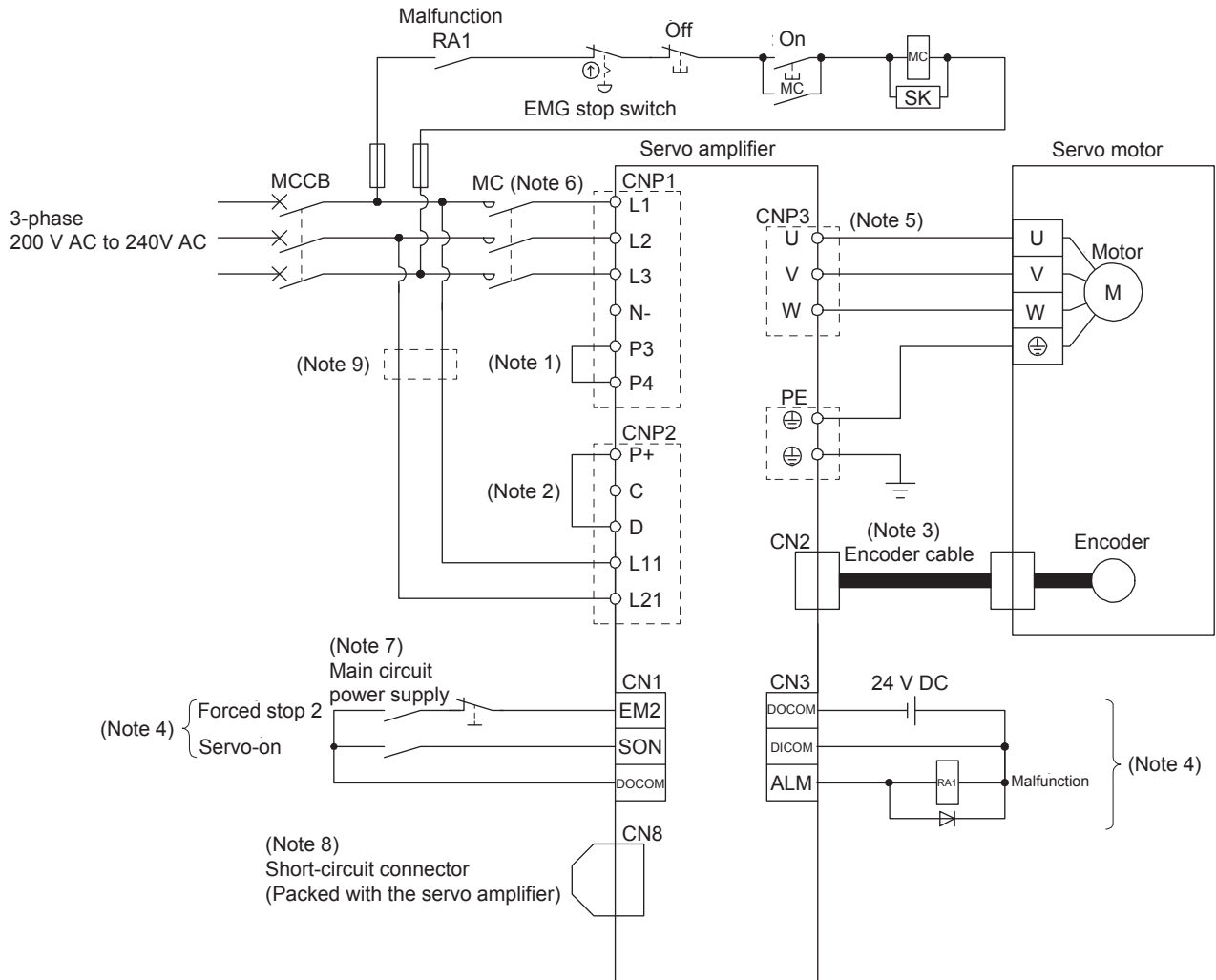

- Note
1. Always connect between P3 and P4 terminals. (factory-wired) When using the power factor improving DC reactor, refer to section 11.11. Use either the power factor improving DC reactor or the power factor improving AC reactor.
 2. Always connect between P+ and D terminals. (factory-wired) When using the regenerative option, refer to section 11.2.
 3. For the encoder cable, use of the option cable is recommended. For selecting cables, refer to Servo Motor Instruction Manual (Vol. 3).
 4. This diagram is for sink I/O interface. For source I/O interface, refer to section 3.9.3.
 5. For connecting servo motor power wires, refer to Servo Motor Instruction Manual (Vol. 3).
 6. Use a magnetic contactor with an operation delay time (interval between current being applied to the coil until closure of contacts) of 80 ms or less. Depending on the main circuit voltage and operation pattern, bus voltage decreases, and that may cause the forced stop deceleration to shift to the dynamic brake deceleration. When dynamic brake deceleration is not required, slow the time to turn off the magnetic contactor.
 7. Configure up a circuit to turn off EM2 when the main circuit power is turned off to prevent an unexpected restart of the servo amplifier.
 8. When not using the STO function, attach a short-circuit connector supplied with a servo amplifier.
 9. When wires used for L11 and L21 are thinner than wires used for L1, L2, and L3, use a molded case circuit breaker. (Refer to section 11.10.)

3. SIGNALS AND WIRING

(2) For 1-phase 200 V AC to 240 V AC power supply of MR-J4-10A to MR-J4-70A

POINT

● Connect the 1-phase 200 V AC to 240 V AC power supply to L1 and L3. One of the connecting destinations is different from MR-J3 Series Servo Amplifier. When using MR-J4 as a replacement for MR-J3, be careful not to connect the power to L2.

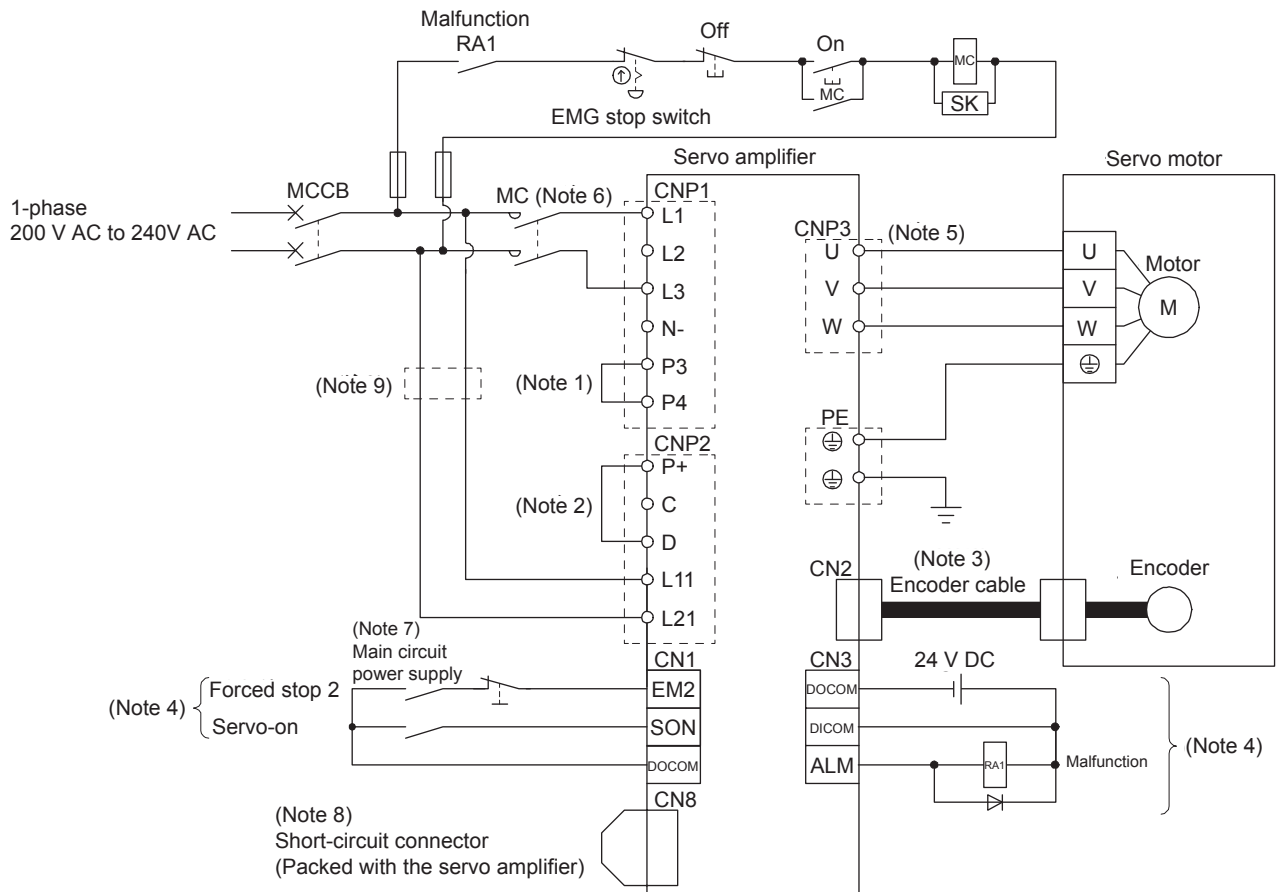

- Note 1. Always connect between P3 and P4 terminals. (factory-wired) When using the power factor improving DC reactor, refer to section 11.11. Use either the power factor improving DC reactor or the power factor improving AC reactor.
- Note 2. Always connect between P+ and D terminals. (factory-wired) When using the regenerative option, refer to section 11.2.
- Note 3. For the encoder cable, use of the option cable is recommended. For selecting cables, refer to Servo Motor Instruction Manual (Vol. 3).
- Note 4. This diagram is for sink I/O interface. For source I/O interface, refer to section 3.9.3.
- Note 5. For connecting servo motor power wires, refer to Servo Motor Instruction Manual (Vol. 3).
- Note 6. Use a magnetic contactor with an operation delay time (interval between current being applied to the coil until closure of contacts) of 80 ms or less. Depending on the main circuit voltage and operation pattern, bus voltage decreases, and that may cause the forced stop deceleration to shift to the dynamic brake deceleration. When dynamic brake deceleration is not required, slow the time to turn off the magnetic contactor.
- Note 7. Configure up a circuit to turn off EM2 when the main circuit power is turned off to prevent an unexpected restart of the servo amplifier.
- Note 8. When not using the STO function, attach a short-circuit connector supplied with a servo amplifier.
- Note 9. When wires used for L11 and L21 are thinner than wires used for L1, and L3, use a molded case circuit breaker. (Refer to section 11.10.)

3. SIGNALS AND WIRING

(3) MR-J4-500A

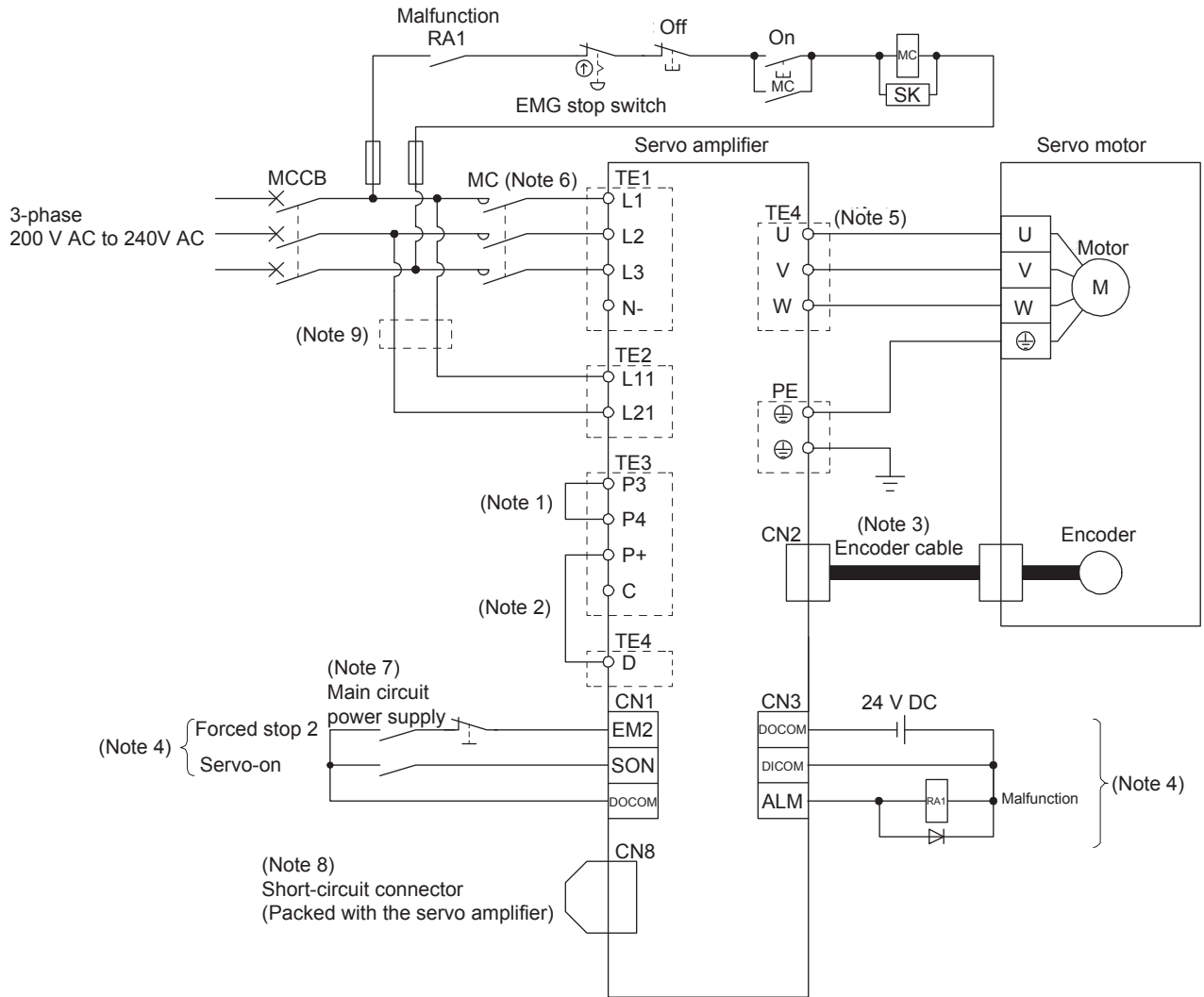

- Note 1. Always connect between P3 and P4 terminals. (factory-wired) When using the power factor improving DC reactor, refer to section 11.11. Use either the power factor improving DC reactor or the power factor improving AC reactor.
- Note 2. Always connect between P+ and D terminals. (factory-wired) When using the regenerative option, refer to section 11.2.
- Note 3. For the encoder cable, use of the option cable is recommended. For selecting cables, refer to Servo Motor Instruction Manual (Vol. 3).
- Note 4. This diagram is for sink I/O interface. For source I/O interface, refer to section 3.9.3.
- Note 5. For connecting servo motor power wires, refer to Servo Motor Instruction Manual (Vol. 3).
- Note 6. Use a magnetic contactor with an operation delay time (interval between current being applied to the coil until closure of contacts) of 80 ms or less. Depending on the main circuit voltage and operation pattern, bus voltage decreases, and that may cause the forced stop deceleration to shift to the dynamic brake deceleration. When dynamic brake deceleration is not required, slow the time to turn off the magnetic contactor.
- Note 7. Configure up a circuit to turn off EM2 when the main circuit power is turned off to prevent an unexpected restart of the servo amplifier.
- Note 8. When not using the STO function, attach a short-circuit connector supplied with a servo amplifier.
- Note 9. When wires used for L11 and L21 are thinner than wires used for L1, L2, and L3, use a molded case circuit breaker. (Refer to section 11.10.)

3. SIGNALS AND WIRING

(4) MR-J4-700A

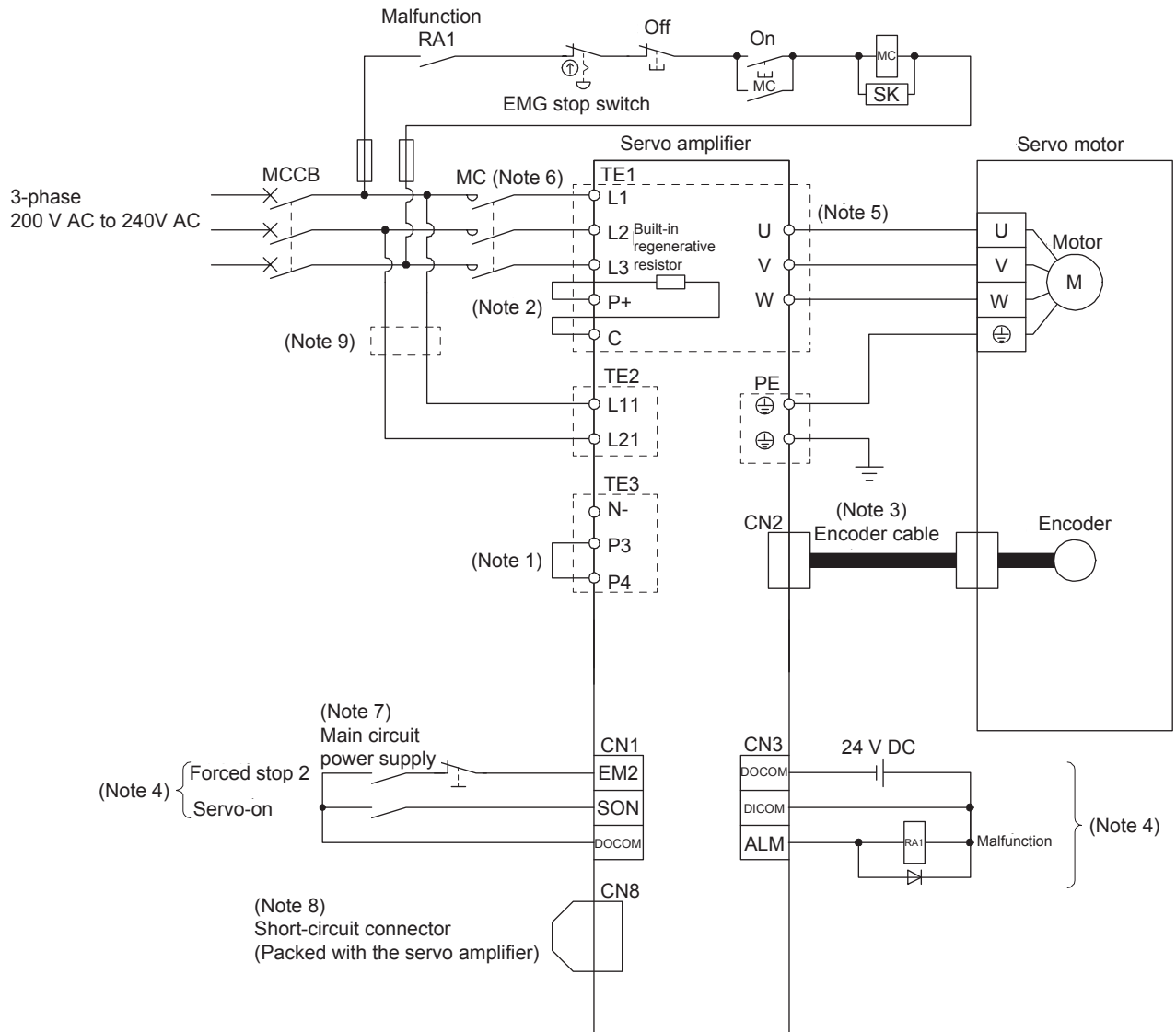

- Note 1. Always connect between P3 and P4 terminals. (factory-wired) When using the power factor improving DC reactor, refer to section 11.11. Use either the power factor improving DC reactor or the power factor improving AC reactor.
- Note 2. When using the regenerative option, refer to section 11.2.
- Note 3. For the encoder cable, use of the option cable is recommended. For selecting cables, refer to Servo Motor Instruction Manual (Vol. 3).
- Note 4. This diagram is for sink I/O interface. For source I/O interface, refer to section 3.9.3.
- Note 5. For connecting servo motor power wires, refer to Servo Motor Instruction Manual (Vol. 3).
- Note 6. Use a magnetic contactor with an operation delay time (interval between current being applied to the coil until closure of contacts) of 80 ms or less. Depending on the main circuit voltage and operation pattern, bus voltage decreases, and that may cause the forced stop deceleration to shift to the dynamic brake deceleration. When dynamic brake deceleration is not required, slow the time to turn off the magnetic contactor.
- Note 7. Configure up a circuit to turn off EM2 when the main circuit power is turned off to prevent an unexpected restart of the servo amplifier.
- Note 8. When not using the STO function, attach a short-circuit connector supplied with a servo amplifier.
- Note 9. When wires used for L11 and L21 are thinner than wires used for L1, L2, and L3, use a molded case circuit breaker. (Refer to section 11.10.)

3. SIGNALS AND WIRING

3.2 I/O signal connection example

3.2.1 Position control mode

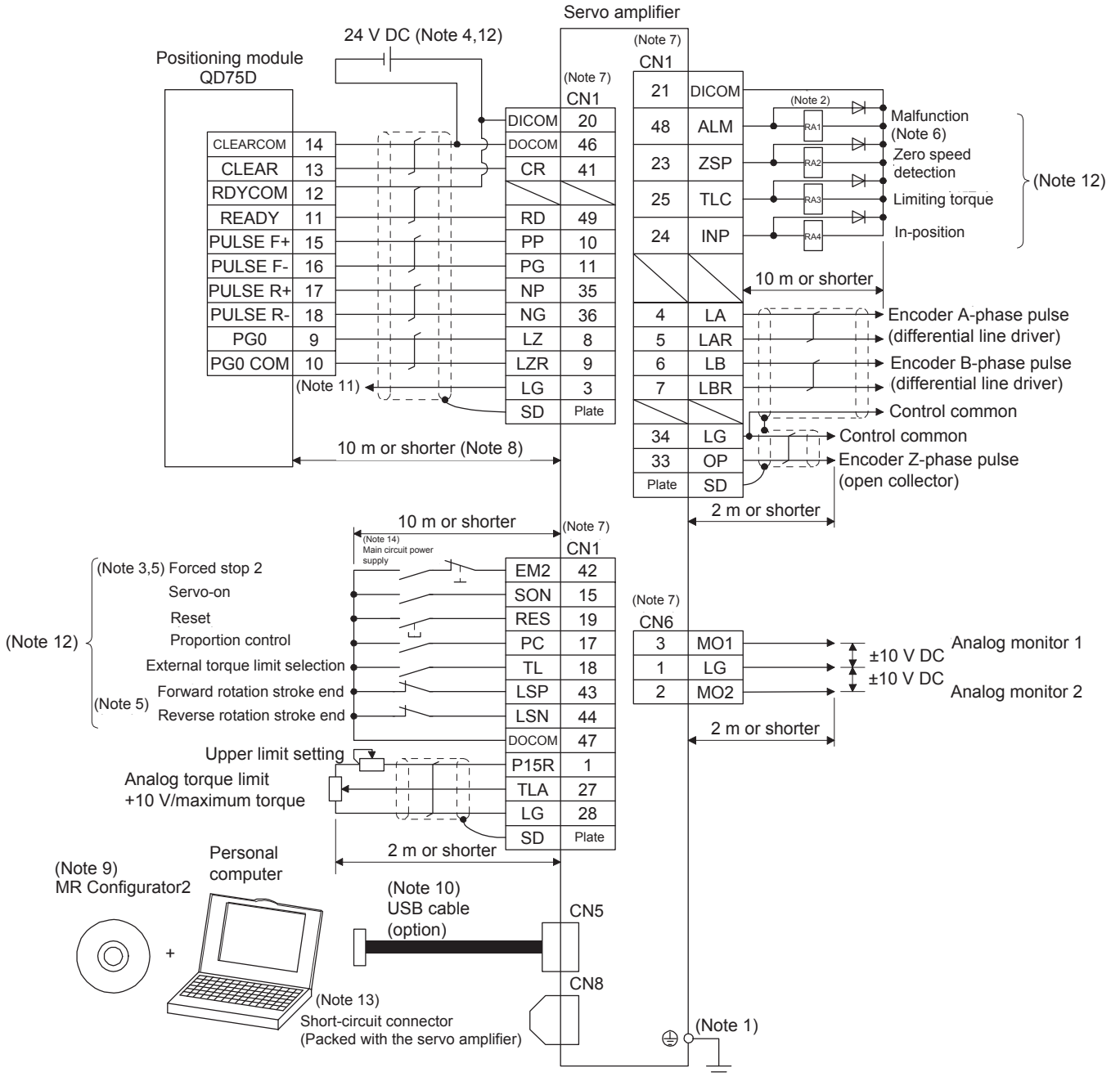

3. SIGNALS AND WIRING

- Note
1. To prevent an electric shock, always connect the protective earth (PE) terminal (marked \oplus) of the servo amplifier to the protective earth (PE) of the cabinet.
 2. Connect the diode in the correct direction. If it is connected reversely, the servo amplifier will malfunction and will not output signals, disabling EM2 (Forced stop 2) and other protective circuits.
 3. When starting operation, always turn on EM2 (Forced stop 2). (Normally closed contact)
 4. Supply 24 V DC \pm 10% 500mA current for interfaces from the outside. 500mA is the value applicable when all I/O signals are used. The current capacity can be decreased by reducing the number of I/O points. Refer to section 3.9.2 (1) that gives the current value necessary for the interface.
 5. When starting operation, always turn on EM2 (Forced stop 2), LSP (Forward rotation stroke end) and LSN (Reverse rotation stroke end). (Normally closed contact)
 6. ALM (Malfunction) turns on in normal alarm-free condition. When this signal is switched off (at occurrence of an alarm), the output of the programmable controller should be stopped by the sequence program.
 7. The pins with the same signal name are connected in the servo amplifier.
 8. This length applies to the command pulse train input in the differential line driver type. It is 2 m or less in the open-collector type.
 9. type.
 10. Use SW1DNC-MRC2-J. (Refer to section 11.7.)
Personal computers can also be connected via the CN3 connector, enabling RS-422 communication (available in the future).
Note that using the USB communication function (CN5 connector) prevents the RS-422 communication function (CN3 connector) from being used, and vice versa. They cannot be used together.

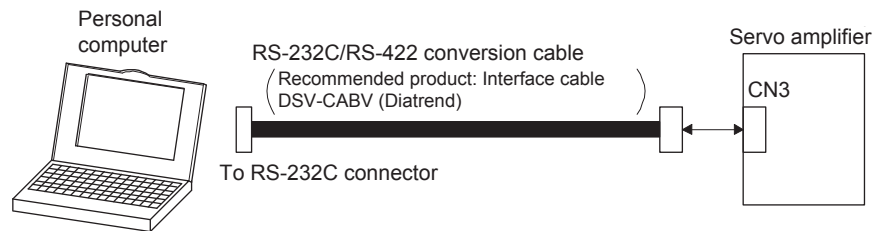

11. This connection is not required for QD75D. However, to enhance noise immunity, it is recommended to connect LG of servo amplifier and control common depending on the positioning module.
12. This diagram is for sink I/O interface. For source I/O interface, refer to section 3.9.3.
13. When not using the STO function, attach a short-circuit connector supplied with a servo amplifier.
14. Configure up a circuit to turn off EM2 when the main circuit power is turned off to prevent an unexpected restart of the servo amplifier.

3. SIGNALS AND WIRING

3.2.2 Speed control mode

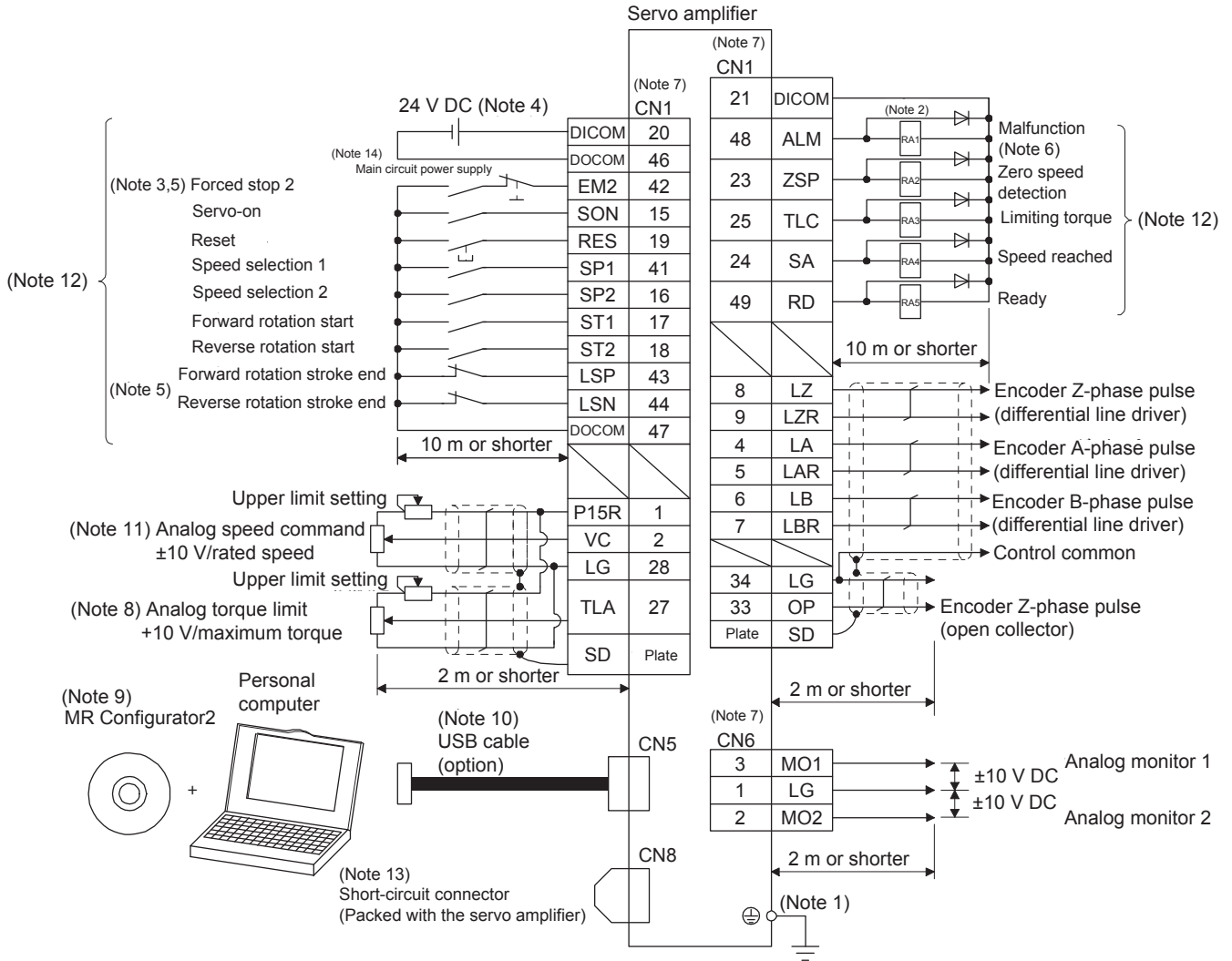

3. SIGNALS AND WIRING

- Note
1. To prevent an electric shock, always connect the protective earth (PE) terminal (marked \oplus) of the servo amplifier to the protective earth (PE) of the cabinet.
 2. Connect the diode in the correct direction. If it is connected reversely, the servo amplifier will malfunction and will not output signals, disabling EM2 (Forced stop 2) and other protective circuits.
 3. When starting operation, always turn on EM2 (Forced stop 2). (Normally closed contact)
 4. Supply 24 V DC \pm 10% 500mA current for interfaces from the outside. 500mA is the value applicable when all I/O signals are used. The current capacity can be decreased by reducing the number of I/O points. Refer to section 3.9.2 (1) that gives the current value necessary for the interface.
 5. When starting operation, always turn on EM2 (Forced stop 2), LSP (Forward rotation stroke end) and LSN (Reverse rotation stroke end). (Normally closed contact)
 6. ALM (Malfunction) turns on in normal alarm-free condition.
 7. The pins with the same signal name are connected in the servo amplifier.
 8. TLA will be available when TL (External torque limit selection) is enabled with [Pr. PD03] to [Pr. PD22]. (Refer to section 3.6.1 9. (5).)
 10. Use SW1DNC-MRC2-J. (Refer to section 11.7.)
Personal computers can also be connected via the CN3 connector, enabling RS-422 communication (available in the future). Note that using the USB communication function (CN5 connector) prevents the RS-422 communication function (CN3 connector) from being used, and vice versa. They cannot be used together.

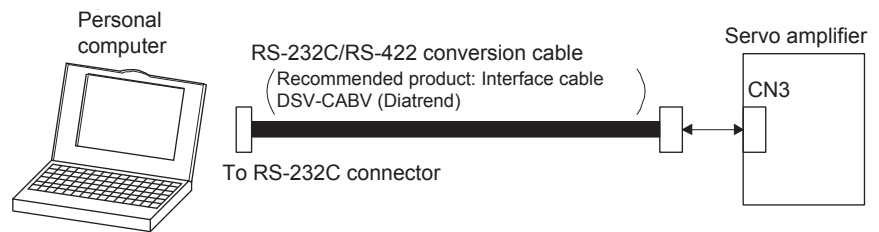

11. Use an external power supply when inputting a negative voltage.
12. This diagram is for sink I/O interface. For source I/O interface, refer to section 3.9.3.
13. When not using the STO function, attach a short-circuit connector supplied with a servo amplifier.
14. Configure up a circuit to turn off EM2 when the main circuit power is turned off to prevent an unexpected restart of the servo amplifier.

3. SIGNALS AND WIRING

3.2.3 Torque control mode

POINT

●EM2 has the same function as EM1 in the torque control mode.

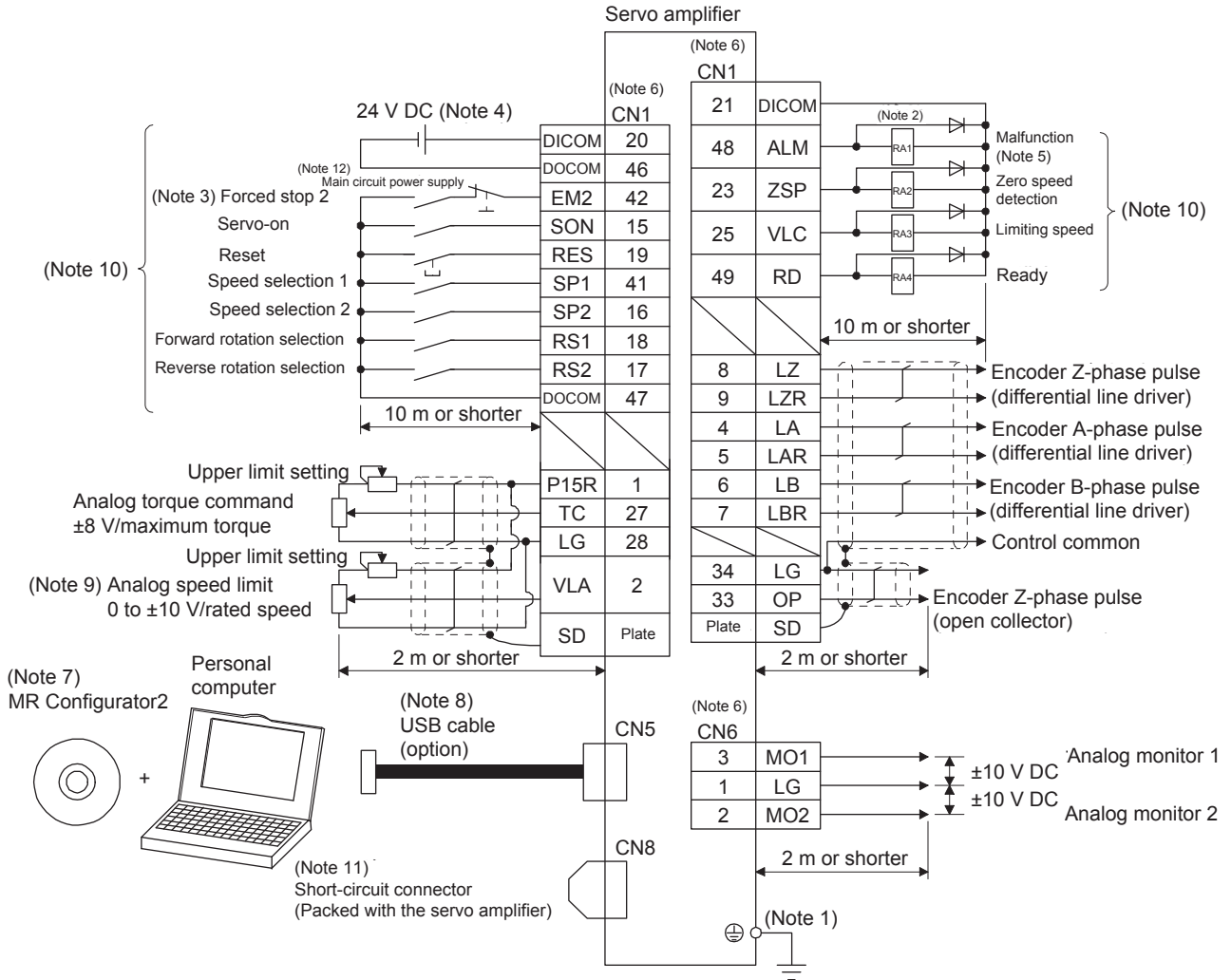

3. SIGNALS AND WIRING

- Note
1. To prevent an electric shock, always connect the protective earth (PE) terminal (marked \oplus) of the servo amplifier to the protective earth (PE) of the cabinet.
 2. Connect the diode in the correct direction. If it is connected reversely, the servo amplifier will malfunction and will not output signals, disabling EM2 (Forced stop 2) and other protective circuits.
 3. When starting operation, always turn on EM2 (Forced stop 2). (Normally closed contact)
 4. Supply 24 V DC \pm 10% 500mA current for interfaces from the outside. 500mA is the value applicable when all I/O signals are used. The current capacity can be decreased by reducing the number of I/O points. Refer to section 3.9.2 (1) that gives the current value necessary for the interface.
 5. ALM (Malfunction) turns on in normal alarm-free condition.
 6. The pins with the same signal name are connected in the servo amplifier.
 7. Use SW1DNC-MRC2-J. (Refer to section 11.7.)
 8. Personal computers can also be connected via the CN3 connector, enabling RS-422 communication (available in the future).
Note that using the USB communication function (CN5 connector) prevents the RS-422 communication function (CN3 connector) from being used, and vice versa. They cannot be used together.

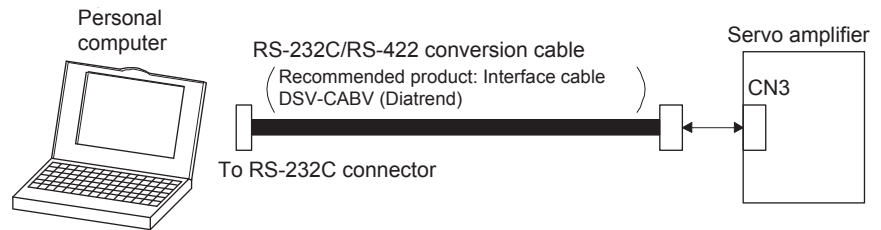

9. Use an external power supply when inputting a negative voltage.
10. This diagram is for sink I/O interface. For source I/O interface, refer to section 3.9.3.
11. When not using the STO function, attach a short-circuit connector supplied with a servo amplifier.
12. Configure up a circuit to turn off EM2 when the main circuit power is turned off to prevent an unexpected restart of the servo amplifier.

3. SIGNALS AND WIRING

3.3 Explanation of power supply system

3.3.1 Signal explanations

| |
|--|
| POINT |
| ● For the layout of connector and terminal block, refer to chapter 9 DIMENSIONS. |

| Symbol | Connection destination (application) | Description | | | | | | | | | |
|--|--------------------------------------|--|---------------------------------|-------------------------|------------------------------|--|----------|--|--|-------|--|
| L1/L2/L3 | Main circuit power supply | <p>Supply the following power to L1, L2, and L3. For 1-phase 200 V AC to 240 V AC, connect the power supply to L1 and L3. Leave L2 open.</p> <table border="1"> <tr> <td style="text-align: center;">Servo amplifier Power supply</td> <td style="text-align: center;">MR-J4-10A to MR-J4-70A</td> <td style="text-align: center;">MR-J4-100A to MR-J4-700A</td> </tr> <tr> <td style="text-align: center;">3-phase 200 V AC to 240 V AC, 50/60 Hz</td> <td colspan="2" style="text-align: center;">L1/L2/L3</td> </tr> <tr> <td style="text-align: center;">1-phase 200 V AC to 240 V AC, 50/60 Hz</td> <td style="text-align: center;">L1/L3</td> <td></td> </tr> </table> | Servo amplifier Power supply | MR-J4-10A to MR-J4-70A | MR-J4-100A to MR-J4-700A | 3-phase 200 V AC to 240 V AC, 50/60 Hz | L1/L2/L3 | | 1-phase 200 V AC to 240 V AC, 50/60 Hz | L1/L3 | |
| Servo amplifier Power supply | MR-J4-10A to MR-J4-70A | MR-J4-100A to MR-J4-700A | | | | | | | | | |
| 3-phase 200 V AC to 240 V AC, 50/60 Hz | L1/L2/L3 | | | | | | | | | | |
| 1-phase 200 V AC to 240 V AC, 50/60 Hz | L1/L3 | | | | | | | | | | |
| P3/P4 | Power factor improving DC reactor | <p>When not using the power factor improving DC reactor, connect P3 and P4. (factory-wired)</p> <p>When using the power factor improving DC reactor, disconnect P3 and P4, and connect the power factor improving DC reactor to P3 and P4.</p> <p>Refer to section 11.11 for details.</p> | | | | | | | | | |
| P+/C/D | Regenerative option | <p>1) MR-J4-500A or less</p> <p>When using a servo amplifier built-in regenerative resistor, connect P+ and D. (factory-wired)</p> <p>When using a regenerative option, disconnect P+ and D, and connect the regenerative option to P+ and C.</p> <p>(2) MR-J4-700A</p> <p>MR-J4-700A does not have D.</p> <p>When using a servo amplifier built-in regenerative resistor, connect P+ and C. (factory-wired)</p> <p>When using a regenerative option, disconnect wires of P+ and C for the built-in regenerative resistor. And then connect wires of the regenerative option to P+ and C.</p> <p>Refer to section 11.2 to 11.5 for details.</p> | | | | | | | | | |
| L11/L21 | Control circuit power supply | <p>Supply the following power to L11 and L21.</p> <table border="1"> <tr> <td style="text-align: center;">Servo amplifier Power supply</td> <td style="text-align: center;">MR-J4-10A to MR-J4-700A</td> </tr> <tr> <td style="text-align: center;">1-phase 200 V AC to 240 V AC</td> <td style="text-align: center;">L11/L21</td> </tr> </table> | Servo amplifier Power supply | MR-J4-10A to MR-J4-700A | 1-phase 200 V AC to 240 V AC | L11/L21 | | | | | |
| Servo amplifier Power supply | MR-J4-10A to MR-J4-700A | | | | | | | | | | |
| 1-phase 200 V AC to 240 V AC | L11/L21 | | | | | | | | | | |
| U/V/W | Servo motor power supply | Connect to the servo motor power supply terminals (U, V, and W). During power-on, do not open or close the servo motor power supply. Otherwise, it may cause a malfunction. | | | | | | | | | |
| N- | Regenerative converter Brake unit | When using a power regenerative converter or brake unit, connect it to P+ and N-. Refer to section 11.3 to 11.5 for details. | | | | | | | | | |
| ⊕ | Protective earth (PE) | Connect it to the grounding terminal of the servo motor and to the protective earth (PE) of the cabinet for grounding. | | | | | | | | | |

3. SIGNALS AND WIRING

3.3.2 Power-on sequence

(1) Power-on procedure

- 1) Always wire the power supply as shown in above section 3.1 using the magnetic contactor with the main circuit power supply (3-phase: L1, L2, and L3, 1-phase: L1 and L3). Configure up an external sequence to switch off the magnetic contactor as soon as an alarm occurs.
- 2) Switch on the control circuit power supply (L11 and L21) simultaneously with the main circuit power supply or before switching on the main circuit power supply. If the main circuit power supply is not on, the display shows the corresponding warning. However, by switching on the main circuit power supply, the warning disappears and the servo amplifier will operate properly.
- 3) The servo amplifier receives the SON (Servo-on) 2.5 s to 3.5 s after the main circuit power supply is switched on. Therefore, when SON (Servo-on) is switched on simultaneously with the main circuit power supply, the base circuit will switch on in about 2.5 s to 3.5 s, and the RD (Ready) will switch on in further about 5 ms, making the servo amplifier ready to operate. (Refer to (2) of this section.)
- 4) When RES (Reset) is switched on, the base circuit is shut off and the servo motor shaft coasts.

(2) Timing chart

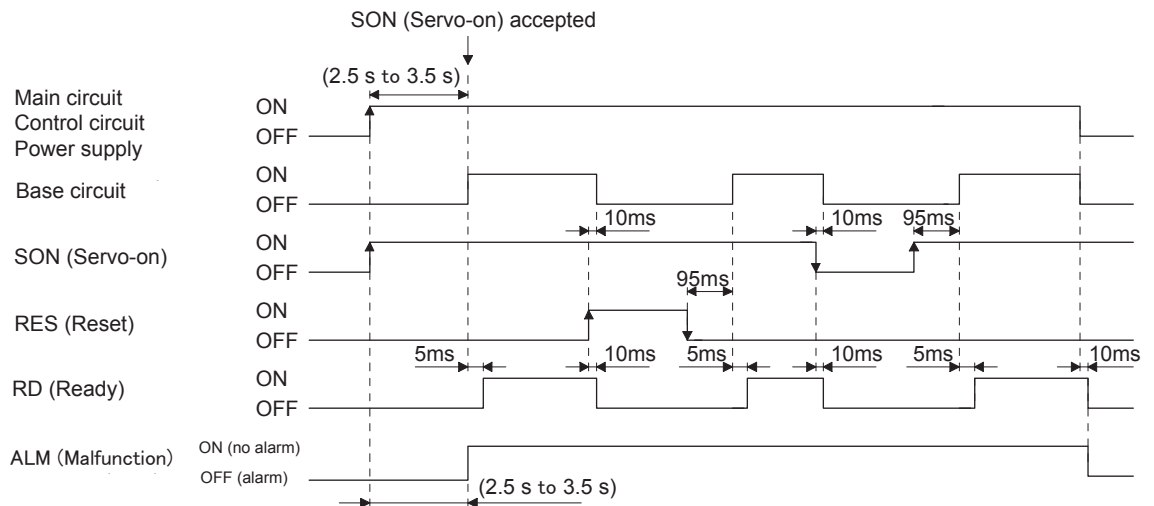

3. SIGNALS AND WIRING

3.3.3 Wiring CNP1, CNP2, and CNP3

| POINT |
|--|
| ● For the sizes of wires used for wiring, refer to section 11.9. |
| ● MR-J3-500A or more do not have these connectors. |

Use the servo amplifier power supply connector for wiring CNP1, CNP2, and CNP3.

(1) Connector

(a) MR-J4-10A to MR-J4-100A

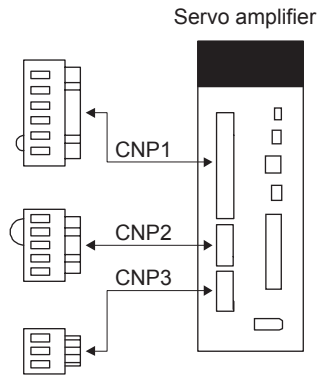

Table 3.1 Connector and applicable wire

| Connector | Receptacle assembly | Applicable wire | | Stripped length [mm] | Open tool | Manufacturer |
|-----------|---------------------|-----------------|------------------|----------------------|-----------|--------------|
| | | Size | Insulator OD | | | |
| CNP1 | 06JFAT-SAXGDK-H7.5 | AWG 18 to 14 | 3.9mm or shorter | 9mm | J-FAT-OT | JST |
| CNP2 | 05JFAT-SAXGDK-H5.0 | | | | | |
| CNP3 | 03JFAT-SAXGDK-H7.5 | | | | | |

(b) MR-J4-200A/MR-J4-350A

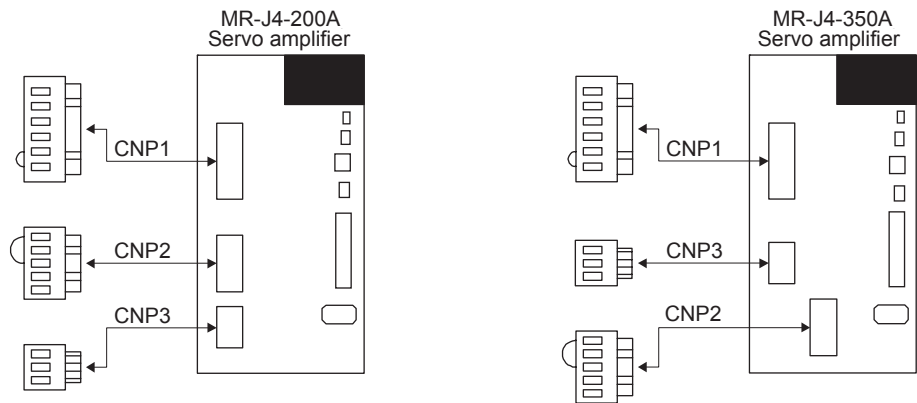

Table 3.2 Connector and applicable wire

| Connector | Receptacle assembly | Applicable wire | | Stripped length [mm] | Open tool | Manufacturer |
|-----------|---------------------|-----------------|------------------|----------------------|--------------|--------------|
| | | Size | Insulator OD | | | |
| CNP1 | 06JFAT-SAXGFK-XL | AWG 16 to 10 | 4.7mm or shorter | 11.5mm | J-FAT-OT-EXL | JST |
| CNP3 | 03JFAT-SAXGFK-XL | | | | | |
| CNP2 | 05JFAT-SAXGDK-H5.0 | AWG 18 to 14 | 3.9mm or shorter | 9mm | | |

3. SIGNALS AND WIRING

(2) Cable connection procedure

(a) Cable making

Refer to table 3.1 and 3.2 for stripped length of cable insulator. The appropriate stripped length of cables depends on their type, etc. Set the length considering their status.

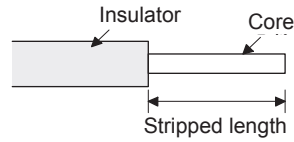

Twist strands slightly and straighten them as follows.

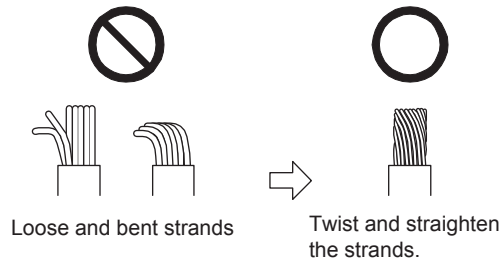

(b) Inserting wire

Insert the open tool as follows and push down it to open the spring. While the open tool is pushed down, insert the stripped wire into the wire insertion hole. Check the insertion depth so that the cable insulator does not get caught by the spring.

Release the open tool to fix the wire. Pull the wire lightly to confirm that the wire is surely connected. The following shows a connection example of the CNP3 connector for 2 kW and 3.5 kW.

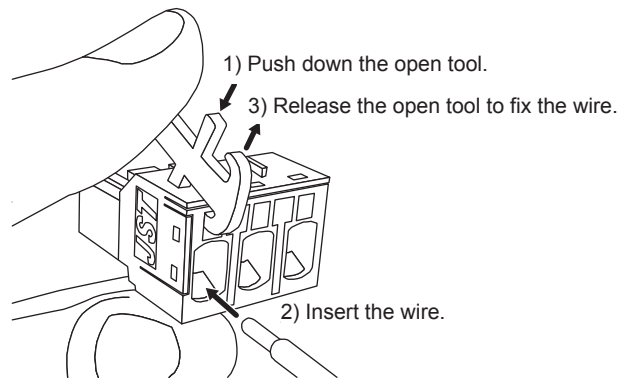

3. SIGNALS AND WIRING

3.4 Connectors and pin assignment

| POINT |
|--|
| <ul style="list-style-type: none">● The pin assignment of the connectors are as viewed from the cable connector wiring section.● For the STO I/O signal connector (CN8), refer to chapter 13.● For the CN1 connector, securely connect the shielded external conductor of the cable to the ground plate and fix it to the connector shell. |

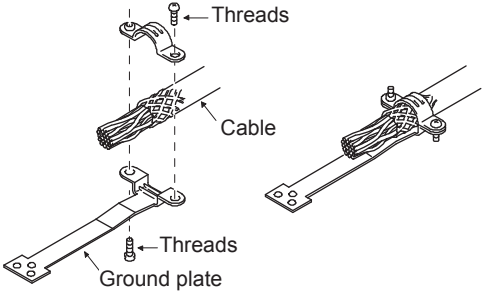

The diagram illustrates the connection of a cable to a ground plate. It shows a cable with a shielded external conductor being connected to a ground plate. The connection is made using screws and nuts. Labels indicate 'Threads' for the screws, 'Cable' for the main cable, and 'Ground plate' for the base component. The diagram shows the assembly from both a top-down perspective and a side view.

3. SIGNALS AND WIRING

The servo amplifier front view shown is that of the MR-J4-20A or less. Refer to chapter 9 DIMENSIONS for the appearances and connector layouts of the other servo amplifiers.

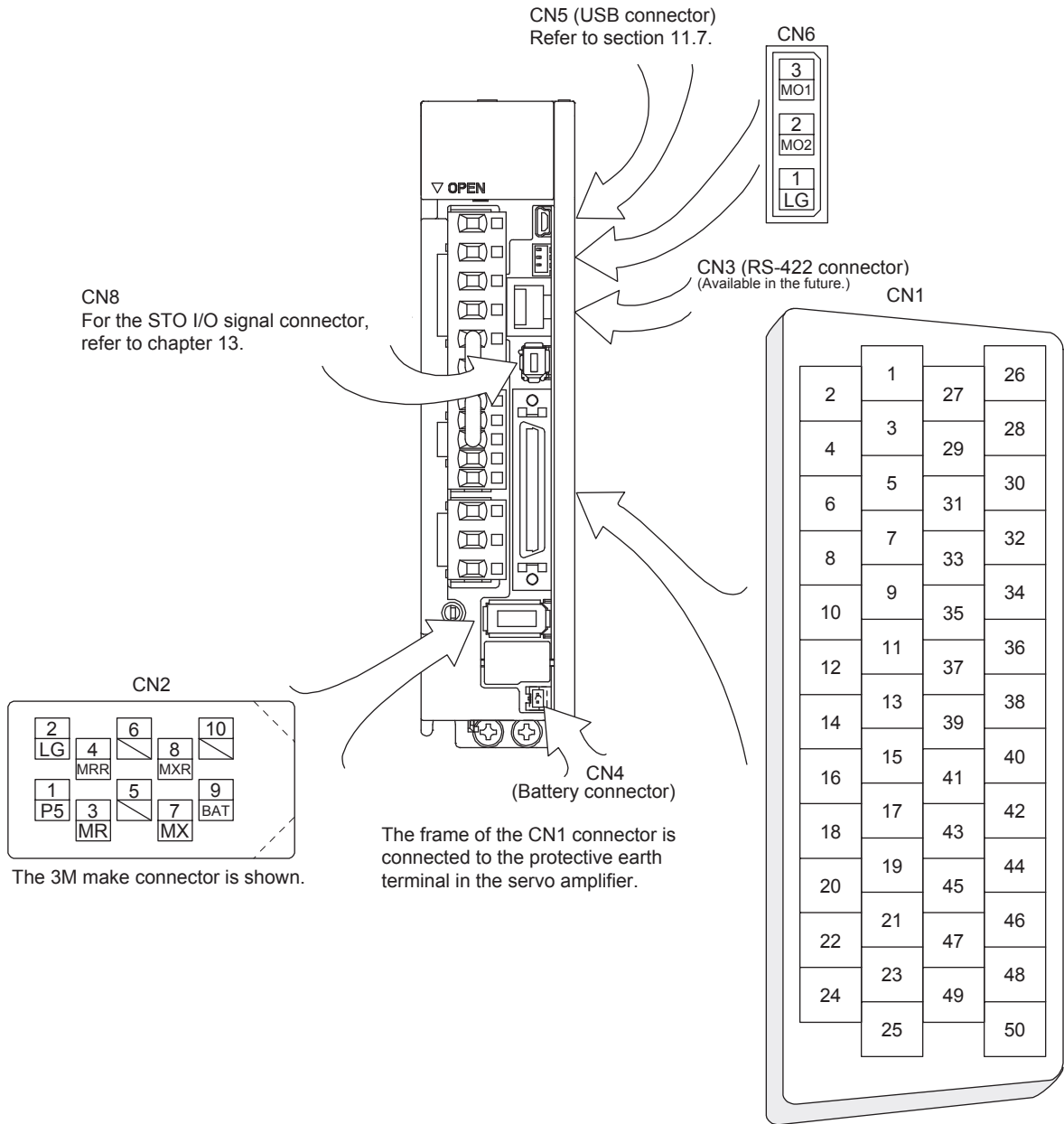

3. SIGNALS AND WIRING

The device assignment of CN1 connector pins changes depending on the control mode. For the pins which are given parameters in the related parameter column, their devices will be changed using those parameters.

| Pin No. | (Note 1) I/O | (Note 2) I/O signals in control modes | | | | | | Related parameter |
|---------|-----------------|---------------------------------------|-----------------|-----------------|--------------------|-------|---------|-------------------|
| | | P | P/S | S | S/T | T | T/P | |
| 1 | | P15R | P15R | P15R | P15R | P15R | P15R | |
| 2 | I | | -/VC | VC | VC/VLA | VLA | VLA/- | |
| 3 | | LG | LG | LG | LG | LG | LG | |
| 4 | O | LA | LA | LA | LA | LA | LA | |
| 5 | O | LAR | LAR | LAR | LAR | LAR | LAR | |
| 6 | O | LB | LB | LB | LB | LB | LB | |
| 7 | O | LBR | LBR | LBR | LBR | LBR | LBR | |
| 8 | O | LZ | LZ | LZ | LZ | LZ | LZ | |
| 9 | O | LZR | LZR | LZR | LZR | LZR | LZR | |
| 10 | I | PP | PP/- | | | | -/PP | |
| 11 | I | PG | PG/- | | | | -/PG | |
| 12 | | OPC | OPC/- | | | | -/OPC | |
| 13 | | | | | | | | |
| 14 | | | | | | | | |
| 15 | I | SON | SON | SON | SON | SON | SON | Pr. PD03/Pr. PD04 |
| 16 | I | | -/SP2 | SP2 | SP2/SP2 | SP2 | SP2/- | Pr. PD05/Pr. PD06 |
| 17 | I | PC | PC/ST1 | ST1 | ST1/RS2 | RS2 | RS2/PC | Pr. PD07/Pr. PD08 |
| 18 | I | TL | TL/ST2 | ST2 | ST2/RS1 | RS1 | RS1/TL | Pr. PD09/Pr. PD10 |
| 19 | I | RES | RES | RES | RES | RES | RES | Pr. PD11/Pr. PD12 |
| 20 | | DICOM | DICOM | DICOM | DICOM | DICOM | DICOM | |
| 21 | | DICOM | DICOM | DICOM | DICOM | DICOM | DICOM | |
| 22 | O | INP | INP/SA | SA | SA/- | | -/INP | Pr. PD23 |
| 23 | O | ZSP | ZSP | ZSP | ZSP | ZSP | ZSP | Pr. PD24 |
| 24 | O | INP | INP/SA | SA | SA/- | | -/INP | Pr. PD25 |
| 25 | O | TLC | TLC | TLC | TLC/MLC | VLC | VLC/TLC | Pr. PD26 |
| 26 | | | | | | | | |
| 27 | I | TLA | (Note 3) TLA | (Note 3) TLA | (Note 3) TLA/TC | TC | TC/TLA | |
| 28 | | LG | LG | LG | LG | LG | LG | |
| 29 | | | | | | | | |
| 30 | | LG | LG | LG | LG | LG | LG | |
| 31 | | | | | | | | |
| 32 | | | | | | | | |
| 33 | O | OP | OP | OP | OP | OP | OP | |
| 34 | | LG | LG | LG | LG | LG | LG | |
| 35 | I | NP | NP/- | | | | -/NP | |
| 36 | I | NG | NG/- | | | | -/NG | |
| 37 | | | | | | | | |
| 38 | | | | | | | | |
| 39 | | | | | | | | |
| 40 | | | | | | | | |
| 41 | I | CR | CR/SP1 | SP1 | SP1/SP1 | SP1 | SP1/CR | Pr. PD13/Pr. PD14 |
| 42 | I | EM2 | EM2 | EM2 | EM2 | EM2 | EM2 | |
| 43 | I | LSP | LSP | LSP | LSP/- | | -/LSP | Pr. PD17/Pr. PD18 |
| 44 | I | LSN | LSN | LSN | LSN/- | | -/LSN | Pr. PD19/Pr. PD20 |
| 45 | I | LOP | LOP | LOP | LOP | LOP | LOP | Pr. PD21/Pr. PD22 |

3. SIGNALS AND WIRING

| Pin No. | (Note 1) I/O | (Note 2) I/O signals in control modes | | | | | | Related parameter |
|---------|-----------------|---------------------------------------|-------|-------|-------|-------|-------|-------------------|
| | | P | P/S | S | S/T | T | T/P | |
| 46 | | DOCOM | DOCOM | DOCOM | DOCOM | DOCOM | DOCOM | |
| 47 | | DOCOM | DOCOM | DOCOM | DOCOM | DOCOM | DOCOM | |
| 48 | O | ALM | ALM | ALM | ALM | ALM | ALM | |
| 49 | O | RD | RD | RD | RD | RD | RD | Pr. PD28 |
| 50 | | | | | | | | |

Note 1. I: input signal, O: output signal

2. P: position control mode, S: speed control mode, T: torque control mode, P/S: position/speed control switching mode, S/T: speed/torque control switching mode, T/P: torque/position control switching mode

3. TLA will be available when TL (External torque limit selection) is enabled with [Pr. PD03] to [Pr. PD22].

3. SIGNALS AND WIRING

3.5 Signal (device) explanations

For the I/O interfaces (symbols in I/O division column in the table), refer to section 3.9.2. In the control mode field of the table

P: position control mode, S: speed control mode, T: torque control mode

○: devices used with initial setting status, △: devices used by setting [Pr. PA04] and [Pr. PD03] to [Pr. PD28]

The pin numbers in the connector pin No. column are those in the initial status.

(1) I/O device

(a) Input device

| Device | Symbol | Connect or pin No. | Function and application | I/O division | Control mode | | | | | | | | | | | | | | | | |
|--------------------|---------|---|---|--------------------|--------------|---------------------|---|-------------------|----------------|---------|-----|---|---|---------|-----|---|---|------|---|---|---|
| | | | | | P | S | T | | | | | | | | | | | | | | |
| Forced stop 2 | EM2 | CN1-42 | <p>Turn off EM2 (open between commons) to decelerate the servo motor to a stop with commands.</p> <p>Turn EM2 on (short between commons) in the forced stop state to reset that state.</p> <p>The following shows the setting of [Pr. PA04].</p> <table border="1" style="width: 100%; border-collapse: collapse;"> <thead> <tr> <th rowspan="2">[Pr. PA04] setting</th> <th rowspan="2">EM2/EM1</th> <th colspan="2">Deceleration method</th> </tr> <tr> <th>EM2 or EM1 is off</th> <th>Alarm occurred</th> </tr> </thead> <tbody> <tr> <td>0 _ _ _</td> <td>EM1</td> <td>MBR (Electromagnetic brake interlock) turns off without the forced stop deceleration.</td> <td>MBR (Electromagnetic brake interlock) turns off without the forced stop deceleration.</td> </tr> <tr> <td>2 0 _ _</td> <td>EM2</td> <td>MBR (Electromagnetic brake interlock) turns off after the forced stop deceleration.</td> <td>MBR (Electromagnetic brake interlock) turns off after the forced stop deceleration.</td> </tr> </tbody> </table> <p>EM2 and EM1 are mutually exclusive. EM2 has the same function as EM1 in the torque control mode.</p> | [Pr. PA04] setting | EM2/EM1 | Deceleration method | | EM2 or EM1 is off | Alarm occurred | 0 _ _ _ | EM1 | MBR (Electromagnetic brake interlock) turns off without the forced stop deceleration. | MBR (Electromagnetic brake interlock) turns off without the forced stop deceleration. | 2 0 _ _ | EM2 | MBR (Electromagnetic brake interlock) turns off after the forced stop deceleration. | MBR (Electromagnetic brake interlock) turns off after the forced stop deceleration. | DI-1 | ○ | ○ | ○ |
| [Pr. PA04] setting | EM2/EM1 | Deceleration method | | | | | | | | | | | | | | | | | | | |
| | | EM2 or EM1 is off | Alarm occurred | | | | | | | | | | | | | | | | | | |
| 0 _ _ _ | EM1 | MBR (Electromagnetic brake interlock) turns off without the forced stop deceleration. | MBR (Electromagnetic brake interlock) turns off without the forced stop deceleration. | | | | | | | | | | | | | | | | | | |
| 2 0 _ _ | EM2 | MBR (Electromagnetic brake interlock) turns off after the forced stop deceleration. | MBR (Electromagnetic brake interlock) turns off after the forced stop deceleration. | | | | | | | | | | | | | | | | | | |
| Forced stop 1 | EM1 | (CN1-42) | <p>When using EM1, set [Pr. PA04] to "0 _ _ _" to enable EM1.</p> <p>Turn EM1 off (open between commons) to bring the motor to an forced stop state. The base circuit is shut off, the dynamic brake is operated and decelerate the servo motor to a stop.</p> <p>Turn EM1 on (short between commons) in the forced stop state to reset that state.</p> | DI-1 | △ | △ | △ | | | | | | | | | | | | | | |
| Servo-on | SON | CN1-15 | <p>Turn SON on to power on the base circuit and make the servo amplifier ready to operate. (servo-on command)</p> <p>Turn it off to shut off the base circuit and coast the servo motor.</p> <p>Set " _ _ _ 4" in [Pr. PD01] to switch this signal on (keep terminals connected) automatically in the servo amplifier.</p> | DI-1 | ○ | ○ | ○ | | | | | | | | | | | | | | |
| Reset | RES | CN1-19 | <p>Turn on RES for more than 50 ms to reset the alarm.</p> <p>Some alarms cannot be deactivated by RES (Reset). Refer to section 8.1.</p> <p>Turning RES on in an alarm-free status shuts off the base circuit. The base circuit is not shut off when " _ _ 1 _" is set in [Pr. PD30].</p> <p>This device is not designed to make a stop. Do not turn on it during operation.</p> | DI-1 | ○ | ○ | ○ | | | | | | | | | | | | | | |

3. SIGNALS AND WIRING

| Device | Symbol | Connect or pin No. | Function and application | I/O division | Control mode | | | | | | | | | | | | | | | | | | | | | | | | | | | | | | | | | | | | | | | | |
|---------------------------------|--------------|--------------------|--|---------------------|--------------|-----------|---|-----|-----|---------------|--------------|---|---|---|---|---|---|---|---|---|---|---|---|---|---|---|---|------------|--------|--|-----|-----|---------|--------------|---|---------|---|--------------|---------|--------------|--------------|------|--|--|--|
| | | | | | P | S | T | | | | | | | | | | | | | | | | | | | | | | | | | | | | | | | | | | | | | | |
| Forward rotation stroke end | LSP | CN1-43 | To start operation, turn on LSP and LSN. Turn it off to bring the motor to a sudden stop and make it servo-locked. Setting [Pr. PD30] to " ___ 1" will enable a slow stop. | DI-1 | ○ | ○ | | | | | | | | | | | | | | | | | | | | | | | | | | | | | | | | | | | | | | | |
| Reverse rotation stroke end | LSN | CN1-44 | <table border="1" style="margin-bottom: 10px;"> <thead> <tr> <th colspan="2">(Note) Input device</th> <th colspan="2">Operation</th> </tr> <tr> <th>LSP</th> <th>LSN</th> <th>CCW direction</th> <th>CW direction</th> </tr> </thead> <tbody> <tr> <td>1</td> <td>1</td> <td>○</td> <td>○</td> </tr> <tr> <td>0</td> <td>1</td> <td>△</td> <td>○</td> </tr> <tr> <td>1</td> <td>0</td> <td>○</td> <td>△</td> </tr> <tr> <td>0</td> <td>0</td> <td>△</td> <td>△</td> </tr> </tbody> </table> <p>Note. 0: Off 1: On</p> <p>Set [Pr. PD01] as indicated below to switch on the signals (keep terminals connected) automatically in the servo amplifier.</p> <table border="1" style="margin-bottom: 10px;"> <thead> <tr> <th rowspan="2">[Pr. PD01]</th> <th colspan="2">Status</th> </tr> <tr> <th>LSP</th> <th>LSN</th> </tr> </thead> <tbody> <tr> <td>_ 4 _ _</td> <td>Automatic on</td> <td>△</td> </tr> <tr> <td>_ 8 _ _</td> <td>△</td> <td>Automatic on</td> </tr> <tr> <td>_ C _ _</td> <td>Automatic on</td> <td>Automatic on</td> </tr> </tbody> </table> <p>When LSP or LSN turns off, [AL. 99 Stroke limit warning] occurs, and WNG (Warning) turns off. When using WNG, enable it by the setting of [Pr. PD23] to [Pr. PD28].</p> | (Note) Input device | | Operation | | LSP | LSN | CCW direction | CW direction | 1 | 1 | ○ | ○ | 0 | 1 | △ | ○ | 1 | 0 | ○ | △ | 0 | 0 | △ | △ | [Pr. PD01] | Status | | LSP | LSN | _ 4 _ _ | Automatic on | △ | _ 8 _ _ | △ | Automatic on | _ C _ _ | Automatic on | Automatic on | DI-1 | | | |
| (Note) Input device | | Operation | | | | | | | | | | | | | | | | | | | | | | | | | | | | | | | | | | | | | | | | | | | |
| LSP | LSN | CCW direction | CW direction | | | | | | | | | | | | | | | | | | | | | | | | | | | | | | | | | | | | | | | | | | |
| 1 | 1 | ○ | ○ | | | | | | | | | | | | | | | | | | | | | | | | | | | | | | | | | | | | | | | | | | |
| 0 | 1 | △ | ○ | | | | | | | | | | | | | | | | | | | | | | | | | | | | | | | | | | | | | | | | | | |
| 1 | 0 | ○ | △ | | | | | | | | | | | | | | | | | | | | | | | | | | | | | | | | | | | | | | | | | | |
| 0 | 0 | △ | △ | | | | | | | | | | | | | | | | | | | | | | | | | | | | | | | | | | | | | | | | | | |
| [Pr. PD01] | Status | | | | | | | | | | | | | | | | | | | | | | | | | | | | | | | | | | | | | | | | | | | | |
| | LSP | LSN | | | | | | | | | | | | | | | | | | | | | | | | | | | | | | | | | | | | | | | | | | | |
| _ 4 _ _ | Automatic on | △ | | | | | | | | | | | | | | | | | | | | | | | | | | | | | | | | | | | | | | | | | | | |
| _ 8 _ _ | △ | Automatic on | | | | | | | | | | | | | | | | | | | | | | | | | | | | | | | | | | | | | | | | | | | |
| _ C _ _ | Automatic on | Automatic on | | | | | | | | | | | | | | | | | | | | | | | | | | | | | | | | | | | | | | | | | | | |
| External torque limit selection | TL | CN1-18 | Turning off TL will enable [Pr. PA11 Forward torque limit] and [Pr. PA12 Reverse torque limit], and turning on it will enable TLA (Analog torque limit). For details, refer to section 3.6.1 (5). | DI-1 | ○ | △ | △ | | | | | | | | | | | | | | | | | | | | | | | | | | | | | | | | | | | | | | |
| Internal torque limit selection | TL1 | | To select [Pr. PC35 Internal torque limit 2], enable TL1 with [Pr. PD03] to [Pr. PD22]. For details, refer to section 3.6.1 (5). | DI-1 | △ | △ | △ | | | | | | | | | | | | | | | | | | | | | | | | | | | | | | | | | | | | | | |
| Forward rotation start | ST1 | CN1-17 | This is used to start the servo motor. The following shows the directions. | DI-1 | | ○ | | | | | | | | | | | | | | | | | | | | | | | | | | | | | | | | | | | | | | | |
| Reverse rotation start | ST2 | CN1-18 | If both ST1 and ST2 are switched on or off during operation, the servo motor will be decelerated to a stop according to the [Pr. PC02] setting and servo-locked. When " ___ 1" is set in [Pr. PC23], the servo motor is not servo-locked after deceleration to a stop. | | | | | | | | | | | | | | | | | | | | | | | | | | | | | | | | | | | | | | | | | | |

3. SIGNALS AND WIRING

| Device | Symbol | Connect or pin No. | Function and application | I/O division | Control mode | | | | | | | | | | | | | | | | | | | | | | | | | | | | | | | | | | | | | | | | | |
|----------------------------|--------|--|--|---------------------|--------------|-----------------------------|---------------|-----|-----|-----|--------------------------|---|---|--|---|---|--|-----------------------------------|---|--------------------------|------|-----------------------------------|---|---|---|-----------------------------------|---|---|---|-----------------------------------|---|---|---|-----------------------------------|---|---|---|-----------------------------------|---|---|---|-----------------------------------|------|--|---|---|
| | | | | | P | S | T | | | | | | | | | | | | | | | | | | | | | | | | | | | | | | | | | | | | | | | |
| Forward rotation selection | RS1 | CN1-18 | This is used to select a servo motor torque generation directions. The following shows the torque generation directions. <table border="1" style="margin: 10px auto;"> <thead> <tr> <th colspan="2">(Note) Input device</th> <th rowspan="2">Torque generation direction</th> </tr> <tr> <th>RS2</th> <th>RS1</th> </tr> </thead> <tbody> <tr> <td>0</td> <td>0</td> <td>Torque is not generated.</td> </tr> <tr> <td>0</td> <td>1</td> <td>Forward rotation in driving mode/reverse rotation in regenerative mode</td> </tr> <tr> <td>1</td> <td>0</td> <td>Reverse rotation in driving mode/forward rotation in regenerative mode</td> </tr> <tr> <td>1</td> <td>1</td> <td>Torque is not generated.</td> </tr> </tbody> </table> Note. 0: Off 1: On | (Note) Input device | | Torque generation direction | RS2 | RS1 | 0 | 0 | Torque is not generated. | 0 | 1 | Forward rotation in driving mode/reverse rotation in regenerative mode | 1 | 0 | Reverse rotation in driving mode/forward rotation in regenerative mode | 1 | 1 | Torque is not generated. | DI-1 | | | ○ | | | | | | | | | | | | | | | | | | | | | | |
| (Note) Input device | | Torque generation direction | | | | | | | | | | | | | | | | | | | | | | | | | | | | | | | | | | | | | | | | | | | | |
| RS2 | RS1 | | | | | | | | | | | | | | | | | | | | | | | | | | | | | | | | | | | | | | | | | | | | | |
| 0 | 0 | Torque is not generated. | | | | | | | | | | | | | | | | | | | | | | | | | | | | | | | | | | | | | | | | | | | | |
| 0 | 1 | Forward rotation in driving mode/reverse rotation in regenerative mode | | | | | | | | | | | | | | | | | | | | | | | | | | | | | | | | | | | | | | | | | | | | |
| 1 | 0 | Reverse rotation in driving mode/forward rotation in regenerative mode | | | | | | | | | | | | | | | | | | | | | | | | | | | | | | | | | | | | | | | | | | | | |
| 1 | 1 | Torque is not generated. | | | | | | | | | | | | | | | | | | | | | | | | | | | | | | | | | | | | | | | | | | | | |
| Reverse rotation selection | RS2 | CN1-17 | | | | | | | | | | | | | | | | | | | | | | | | | | | | | | | | | | | | | | | | | | | | |
| Speed selection 1 | SP1 | CN1-41 | 1. For speed control mode This is used to select the command speed for operation. <table border="1" style="margin: 10px auto;"> <thead> <tr> <th colspan="3">(Note) Input device</th> <th rowspan="2">Speed command</th> </tr> <tr> <th>SP3</th> <th>SP2</th> <th>SP1</th> </tr> </thead> <tbody> <tr> <td>0</td> <td>0</td> <td>0</td> <td>VC (Analog speed command)</td> </tr> <tr> <td>0</td> <td>0</td> <td>1</td> <td>Pr. PC05 Internal speed command 1</td> </tr> <tr> <td>0</td> <td>1</td> <td>0</td> <td>Pr. PC06 Internal speed command 2</td> </tr> <tr> <td>0</td> <td>1</td> <td>1</td> <td>Pr. PC07 Internal speed command 3</td> </tr> <tr> <td>1</td> <td>0</td> <td>0</td> <td>Pr. PC08 Internal speed command 4</td> </tr> <tr> <td>1</td> <td>0</td> <td>1</td> <td>Pr. PC09 Internal speed command 5</td> </tr> <tr> <td>1</td> <td>1</td> <td>0</td> <td>Pr. PC10 Internal speed command 6</td> </tr> <tr> <td>1</td> <td>1</td> <td>1</td> <td>Pr. PC11 Internal speed command 7</td> </tr> </tbody> </table> Note. 0: Off 1: On | (Note) Input device | | | Speed command | SP3 | SP2 | SP1 | 0 | 0 | 0 | VC (Analog speed command) | 0 | 0 | 1 | Pr. PC05 Internal speed command 1 | 0 | 1 | 0 | Pr. PC06 Internal speed command 2 | 0 | 1 | 1 | Pr. PC07 Internal speed command 3 | 1 | 0 | 0 | Pr. PC08 Internal speed command 4 | 1 | 0 | 1 | Pr. PC09 Internal speed command 5 | 1 | 1 | 0 | Pr. PC10 Internal speed command 6 | 1 | 1 | 1 | Pr. PC11 Internal speed command 7 | DI-1 | | ○ | ○ |
| (Note) Input device | | | | Speed command | | | | | | | | | | | | | | | | | | | | | | | | | | | | | | | | | | | | | | | | | | |
| SP3 | SP2 | SP1 | | | | | | | | | | | | | | | | | | | | | | | | | | | | | | | | | | | | | | | | | | | | |
| 0 | 0 | 0 | VC (Analog speed command) | | | | | | | | | | | | | | | | | | | | | | | | | | | | | | | | | | | | | | | | | | | |
| 0 | 0 | 1 | Pr. PC05 Internal speed command 1 | | | | | | | | | | | | | | | | | | | | | | | | | | | | | | | | | | | | | | | | | | | |
| 0 | 1 | 0 | Pr. PC06 Internal speed command 2 | | | | | | | | | | | | | | | | | | | | | | | | | | | | | | | | | | | | | | | | | | | |
| 0 | 1 | 1 | Pr. PC07 Internal speed command 3 | | | | | | | | | | | | | | | | | | | | | | | | | | | | | | | | | | | | | | | | | | | |
| 1 | 0 | 0 | Pr. PC08 Internal speed command 4 | | | | | | | | | | | | | | | | | | | | | | | | | | | | | | | | | | | | | | | | | | | |
| 1 | 0 | 1 | Pr. PC09 Internal speed command 5 | | | | | | | | | | | | | | | | | | | | | | | | | | | | | | | | | | | | | | | | | | | |
| 1 | 1 | 0 | Pr. PC10 Internal speed command 6 | | | | | | | | | | | | | | | | | | | | | | | | | | | | | | | | | | | | | | | | | | | |
| 1 | 1 | 1 | Pr. PC11 Internal speed command 7 | | | | | | | | | | | | | | | | | | | | | | | | | | | | | | | | | | | | | | | | | | | |
| Speed selection 2 | SP2 | CN1-16 | | DI-1 | | ○ | ○ | | | | | | | | | | | | | | | | | | | | | | | | | | | | | | | | | | | | | | | |
| Speed selection 3 | SP3 | | 2. For the torque control mode This is used to select the limit speed for operation. <table border="1" style="margin: 10px auto;"> <thead> <tr> <th colspan="3">(Note) Input device</th> <th rowspan="2">Speed limit</th> </tr> <tr> <th>SP3</th> <th>SP2</th> <th>SP1</th> </tr> </thead> <tbody> <tr> <td>0</td> <td>0</td> <td>0</td> <td>VLA (Analog speed limit)</td> </tr> <tr> <td>0</td> <td>0</td> <td>1</td> <td>Pr. PC05 Internal speed limit 1</td> </tr> <tr> <td>0</td> <td>1</td> <td>0</td> <td>Pr. PC06 Internal speed limit 2</td> </tr> <tr> <td>0</td> <td>1</td> <td>1</td> <td>Pr. PC07 Internal speed limit 3</td> </tr> <tr> <td>1</td> <td>0</td> <td>0</td> <td>Pr. PC08 Internal speed limit 4</td> </tr> <tr> <td>1</td> <td>0</td> <td>1</td> <td>Pr. PC09 Internal speed limit 5</td> </tr> <tr> <td>1</td> <td>1</td> <td>0</td> <td>Pr. PC10 Internal speed limit 6</td> </tr> <tr> <td>1</td> <td>1</td> <td>1</td> <td>Pr. PC11 Internal speed limit 7</td> </tr> </tbody> </table> Note. 0: Off 1: On | (Note) Input device | | | Speed limit | SP3 | SP2 | SP1 | 0 | 0 | 0 | VLA (Analog speed limit) | 0 | 0 | 1 | Pr. PC05 Internal speed limit 1 | 0 | 1 | 0 | Pr. PC06 Internal speed limit 2 | 0 | 1 | 1 | Pr. PC07 Internal speed limit 3 | 1 | 0 | 0 | Pr. PC08 Internal speed limit 4 | 1 | 0 | 1 | Pr. PC09 Internal speed limit 5 | 1 | 1 | 0 | Pr. PC10 Internal speed limit 6 | 1 | 1 | 1 | Pr. PC11 Internal speed limit 7 | DI-1 | | △ | △ |
| (Note) Input device | | | Speed limit | | | | | | | | | | | | | | | | | | | | | | | | | | | | | | | | | | | | | | | | | | | |
| SP3 | SP2 | SP1 | | | | | | | | | | | | | | | | | | | | | | | | | | | | | | | | | | | | | | | | | | | | |
| 0 | 0 | 0 | VLA (Analog speed limit) | | | | | | | | | | | | | | | | | | | | | | | | | | | | | | | | | | | | | | | | | | | |
| 0 | 0 | 1 | Pr. PC05 Internal speed limit 1 | | | | | | | | | | | | | | | | | | | | | | | | | | | | | | | | | | | | | | | | | | | |
| 0 | 1 | 0 | Pr. PC06 Internal speed limit 2 | | | | | | | | | | | | | | | | | | | | | | | | | | | | | | | | | | | | | | | | | | | |
| 0 | 1 | 1 | Pr. PC07 Internal speed limit 3 | | | | | | | | | | | | | | | | | | | | | | | | | | | | | | | | | | | | | | | | | | | |
| 1 | 0 | 0 | Pr. PC08 Internal speed limit 4 | | | | | | | | | | | | | | | | | | | | | | | | | | | | | | | | | | | | | | | | | | | |
| 1 | 0 | 1 | Pr. PC09 Internal speed limit 5 | | | | | | | | | | | | | | | | | | | | | | | | | | | | | | | | | | | | | | | | | | | |
| 1 | 1 | 0 | Pr. PC10 Internal speed limit 6 | | | | | | | | | | | | | | | | | | | | | | | | | | | | | | | | | | | | | | | | | | | |
| 1 | 1 | 1 | Pr. PC11 Internal speed limit 7 | | | | | | | | | | | | | | | | | | | | | | | | | | | | | | | | | | | | | | | | | | | |

3. SIGNALS AND WIRING

| Device | Symbol | Connect or pin No. | Function and application | I/O division | Control mode | | | | | | | | | | | | | | | | | | | |
|-----------------------------|--------|---------------------------|--|---------------------|--------------|---------------------------|-----|-----|---|---|----------|---|---|----------|---|---|----------|---|---|----------|------|---|--|--|
| | | | | | P | S | T | | | | | | | | | | | | | | | | | |
| Proportion control | PC | CN1-17 | <p>Turn PC on to switch the speed amplifier from the proportional integral type to the proportional type.</p> <p>If the servo motor at a stop is rotated even one pulse due to any external factor, it generates torque to compensate for a position shift. When the servo motor shaft is to be locked mechanically after positioning completion (stop), switching on the PC (Proportion control) upon positioning completion will suppress the unnecessary torque generated to compensate for a position shift.</p> <p>When the shaft is to be locked for a long time, switch on the PC (Proportion control) and TL (External torque limit selection) at the same time to make the torque less than the rated by TLA (Analog torque limit).</p> | DI-1 | ○ | △ | | | | | | | | | | | | | | | | | | |
| Clear | CR | CN1-41 | <p>Turn CR on to clear the position control counter droop pulse on its leading edge. The pulse width should be 10 ms or longer.</p> <p>The delay amount set in [Pr. PB03 Position command acceleration/deceleration time constant] is also cleared. When " ___1 " is set to [Pr. PD32], the pulses are always cleared while CR is on.</p> | DI-1 | ○ | | | | | | | | | | | | | | | | | | | |
| Electronic gear selection 1 | CM1 | | <p>The combination of CM1 and CM2 enables you to select four different electronic gear numerators set in the parameters.</p> <p>CM1 and CM2 cannot be used in the absolute position detection system.</p> <table border="1" data-bbox="588 878 1139 1099"> <thead> <tr> <th colspan="2">(Note) Input device</th> <th rowspan="2">Electronic gear numerator</th> </tr> <tr> <th>CM2</th> <th>CM1</th> </tr> </thead> <tbody> <tr> <td>0</td> <td>0</td> <td>Pr. PA06</td> </tr> <tr> <td>0</td> <td>1</td> <td>Pr. PC32</td> </tr> <tr> <td>1</td> <td>0</td> <td>Pr. PC33</td> </tr> <tr> <td>1</td> <td>1</td> <td>Pr. PC34</td> </tr> </tbody> </table> <p>Note. 0: Off 1: On</p> | (Note) Input device | | Electronic gear numerator | CM2 | CM1 | 0 | 0 | Pr. PA06 | 0 | 1 | Pr. PC32 | 1 | 0 | Pr. PC33 | 1 | 1 | Pr. PC34 | DI-1 | △ | | |
| (Note) Input device | | Electronic gear numerator | | | | | | | | | | | | | | | | | | | | | | |
| CM2 | CM1 | | | | | | | | | | | | | | | | | | | | | | | |
| 0 | 0 | Pr. PA06 | | | | | | | | | | | | | | | | | | | | | | |
| 0 | 1 | Pr. PC32 | | | | | | | | | | | | | | | | | | | | | | |
| 1 | 0 | Pr. PC33 | | | | | | | | | | | | | | | | | | | | | | |
| 1 | 1 | Pr. PC34 | | | | | | | | | | | | | | | | | | | | | | |
| Electronic gear selection 2 | CM2 | | | DI-1 | △ | | | | | | | | | | | | | | | | | | | |

3. SIGNALS AND WIRING

| Device | Symbol | Connect or pin No. | Function and application | I/O division | Control mode | | | | | | | | | | | | | | | | | | | | |
|--|--|--------------------|--|--------------|---|---|--|---|--|------------|--------------|---|-------|---|--------|------------|--------------|---|--------|---|----------|------|--------------------------------|--|--|
| | | | | | P | S | T | | | | | | | | | | | | | | | | | | |
| Gain switching | CDP | | Turn on CDP to change the load to motor inertia ratio and gain values to the values of [Pr. PB26] to [Pr. PB22] and [Pr. PB56] to [Pr. PB60]. | DI-1 | △ | △ | △ | | | | | | | | | | | | | | | | | | |
| Control switching | LOP | CN1-45 | <p>«Position/speed control change mode» This is used to select the control mode in the position/speed control switching mode.</p> <table border="1"> <thead> <tr> <th>(Note) LOP</th> <th>Control mode</th> </tr> </thead> <tbody> <tr> <td>0</td> <td>Position</td> </tr> <tr> <td>1</td> <td>Speed</td> </tr> </tbody> </table> <p>Note. 0: Off 1: On</p> <p>«Speed/torque control change mode» This is used to select the control mode in the speed/torque control switching mode.</p> <table border="1"> <thead> <tr> <th>(Note) LOP</th> <th>Control mode</th> </tr> </thead> <tbody> <tr> <td>0</td> <td>Speed</td> </tr> <tr> <td>1</td> <td>Torque</td> </tr> </tbody> </table> <p>Note. 0: Off 1: On</p> <p>«Torque/position control change mode» This is used to select the control mode in the torque/position control switching mode.</p> <table border="1"> <thead> <tr> <th>(Note) LOP</th> <th>Control mode</th> </tr> </thead> <tbody> <tr> <td>0</td> <td>Torque</td> </tr> <tr> <td>1</td> <td>Position</td> </tr> </tbody> </table> <p>Note. 0: Off 1: On</p> | (Note) LOP | Control mode | 0 | Position | 1 | Speed | (Note) LOP | Control mode | 0 | Speed | 1 | Torque | (Note) LOP | Control mode | 0 | Torque | 1 | Position | DI-1 | Refer to Function/application. | | |
| (Note) LOP | Control mode | | | | | | | | | | | | | | | | | | | | | | | | |
| 0 | Position | | | | | | | | | | | | | | | | | | | | | | | | |
| 1 | Speed | | | | | | | | | | | | | | | | | | | | | | | | |
| (Note) LOP | Control mode | | | | | | | | | | | | | | | | | | | | | | | | |
| 0 | Speed | | | | | | | | | | | | | | | | | | | | | | | | |
| 1 | Torque | | | | | | | | | | | | | | | | | | | | | | | | |
| (Note) LOP | Control mode | | | | | | | | | | | | | | | | | | | | | | | | |
| 0 | Torque | | | | | | | | | | | | | | | | | | | | | | | | |
| 1 | Position | | | | | | | | | | | | | | | | | | | | | | | | |
| Second acceleration/deceleration selection | STAB2 | | <p>The device allows selection of the acceleration/deceleration time constant at servo motor rotation in the speed control mode or torque control mode. The s-pattern acceleration/deceleration time constant is always uniform.</p> <table border="1"> <thead> <tr> <th>(Note) STAB2</th> <th>Acceleration/deceleration time constant</th> </tr> </thead> <tbody> <tr> <td>0</td> <td>Pr. PC01 Acceleration time constant Pr. PC02 Deceleration time constant</td> </tr> <tr> <td>1</td> <td>Pr. PC30 Acceleration time constant 2 Pr. PC31 Deceleration time constant 2</td> </tr> </tbody> </table> <p>Note. 0: Off 1: On</p> | (Note) STAB2 | Acceleration/deceleration time constant | 0 | Pr. PC01 Acceleration time constant Pr. PC02 Deceleration time constant | 1 | Pr. PC30 Acceleration time constant 2 Pr. PC31 Deceleration time constant 2 | DI-1 | | △ | △ | | | | | | | | | | | | |
| (Note) STAB2 | Acceleration/deceleration time constant | | | | | | | | | | | | | | | | | | | | | | | | |
| 0 | Pr. PC01 Acceleration time constant Pr. PC02 Deceleration time constant | | | | | | | | | | | | | | | | | | | | | | | | |
| 1 | Pr. PC30 Acceleration time constant 2 Pr. PC31 Deceleration time constant 2 | | | | | | | | | | | | | | | | | | | | | | | | |
| ABS transfer mode | ABSM | CN1-17 | <p>This is an ABS transfer mode request device. When "___ 1" is set in [Pr. PA03] and absolute position detection system by DIO is selected, CN1-17 pin will become ABSM. (Refer to chapter 12.)</p> | DI-1 | △ | | | | | | | | | | | | | | | | | | | | |
| ABS request | ABSR | CN1-18 | <p>This is an ABS request device. When "___ 1" is set in [Pr. PA03] and absolute position detection system by DIO is selected, CN1-18 pin will become ABSR. (Refer to chapter 12.)</p> | DI-1 | △ | | | | | | | | | | | | | | | | | | | | |

3. SIGNALS AND WIRING

(b) Output device

| Device | Symbol | Connect or pin No. | Function and application | I/O division | Control mode | | |
|---------------------------------|--------|--------------------|--|--------------|--------------|---|---|
| | | | | | P | S | T |
| Malfunction | ALM | CN1-48 | When an alarm occurs, ALM will turn off. When an alarm does not occur, ALM will turn on after 2.5 s to 3.5 s after power-on. When [Pr. PD34] is "_ _ 1 _", an alarming or warning will turn off ALM. | DO-1 | ○ | ○ | ○ |
| Ready | RD | CN1-49 | Enabling servo-on to make the servo amplifier ready to operate will turn on RD. | DO-1 | ○ | ○ | ○ |
| In-position | INP | CN1-22 CN1-24 | When the number of droop pulses is in the preset in-position range, INP will turn on. The in-position range can be changed using [Pr. PA10]. When the in-position range is increased, INP may be on during low-speed rotation. INP turns on when servo-on turns on. | DO-1 | ○ | / | / |
| Speed reached | SA | | When the servo motor speed reaches approximately setting speed, SA will turn on. When the preset speed is 20 r/min or less, SA always turns on. SA does not turn on even when the SON (Servo-on) is turned off or the servo motor speed by the external force reaches the preset speed while both ST1 (Forward rotation start) and ST2 (reverse rotation start) are off. | DO-1 | / | ○ | / |
| Limiting speed | VLC | CN1-25 | VLC turns on when speed reaches a value limited with any of [Pr. PC05 Internal speed limit 1] to [Pr. PC11 Internal speed limit 7] or VLA (Analog speed limit). This turns off when SON (Servo-on) turns off. | DO-1 | / | / | ○ |
| Limiting torque | TLC | | TLC turns on when a generated torque reaches a value set with any of [Pr. PA11 Forward torque limit], [Pr. PA12 Reverse torque limit], or TLA (Analog torque limit). | DO-1 | ○ | ○ | / |
| Zero speed detection | ZSP | CN1-23 | ZSP turns on when the servo motor speed is zero speed (50r/min) or less. Zero speed can be changed with [Pr. PC17]. <div style="display: flex; align-items: flex-start;"> <div style="margin-right: 20px;"> <p>Forward rotation direction ↑</p> <p>OFF level 70 r/min</p> <p>ON level 50 r/min</p> <p>Servo motor speed 0 r/min</p> <p>Reverse rotation direction ↓</p> <p>ON level -50 r/min</p> <p>OFF level -70 r/min</p> <p>ZSP (Zero speed detection)</p> <p>ON</p> <p>OFF</p> </div> <div style="margin-left: 20px;"> <p>1) 2) 3) 4)</p> <p>20 r/min (Hysteresis width) [Pr. PC17]</p> <p>20 r/min (Hysteresis width) [Pr. PC17]</p> </div> </div> <p>ZSP will turn on when the servo motor is decelerated to 50 r/min (at 1)), and will turn off when the servo motor is accelerated to 70 r/min again (at 2)). ZSP will turn on when the servo motor is decelerated again to 50 r/min (at 3)), and will turn off when the servo motor speed has reached -70 r/min (at 4)). The range from the point when the servo motor speed has reached on level, and ZSP turns on, to the point when it is accelerated again and has reached off level is called hysteresis width. Hysteresis width is 20 r/min for this servo amplifier.</p> | DO-1 | ○ | ○ | ○ |
| Electromagnetic brake interlock | MBR | / | When using the device, set operation delay time of the electromagnetic brake in [Pr. PC16]. When a servo-off status or alarm occurs, MBR will turn off. | DO-1 | △ | △ | △ |
| Warning | WNG | / | When warning has occurred, WNG turns on. When a warning is not occurring, turning on the power will turn off WNG after 2.5 s to 3.5 s. | DO-1 | △ | △ | △ |
| Battery warning | BWNG | / | BWNG turns on when [AL. 92 Battery cable disconnection warning] or [AL. 9F Battery warning] has occurred. When the battery warning is not occurring, turning on the power will turn off BWNG after 2.5 s to 3.5 s. | DO-1 | △ | △ | △ |

3. SIGNALS AND WIRING

| Device | Symbol | Connect or pin No. | Function and application | I/O division | Control mode | | |
|--------------------------------|--------|--------------------|---|--------------|--------------|---|---|
| | | | | | P | S | T |
| Alarm code | ACD0 | (CN1-24) | To use these signals, set "___ 1" in [Pr. PD34]. This signal is output when an alarm occurs. When an alarm is not occurring, respective ordinary signals are output. For details of the alarm codes, refer to chapter 8. When "Enabled (absolute position detection system by DIO) (___ 1)" is selected in [Pr. PA03] and when MBR, DB, or ALM is assigned to CN1-22 pin, CN1-23 pin, or CN1-24 pin, selecting alarm code output will generate [AL. Parameter error]. | DI-1 | △ | △ | △ |
| | ACD1 | (CN1-23) | | | | | |
| | ACD2 | (CN1-22) | | | | | |
| Variable gain selection | CDPS | | CDPS turns on during gain switching. | DO-1 | △ | △ | △ |
| Absolute position undetermined | ABSV | | ABSV turns on when the absolute position is undetermined. | DO-1 | △ | | |
| ABS transmission data bit 0 | ABSB0 | (CN1-22) | This is used to output ABS transmission data bit 0. When "Enabled (absolute position detection system by DIO) (___ 1)" is selected in [Pr. PA03], CN1-22 pin will become ABSB0 only during ABS transfer mode. (Refer to chapter 12.) | DO-1 | △ | | |
| ABS transmission data bit 1 | ABSB1 | (CN1-23) | This is used to output ABS transmission data bit 1. When "Enabled (absolute position detection system by DIO) (___ 1)" is selected in [Pr. PA03], CN1-23 pin will become ABSB1 only during ABS transfer mode. (Refer to chapter 12.) | DO-1 | △ | | |
| ABS transmission data ready | ABST | (CN1-25) | This is used to output ABS transmission data ready. When "Enabled (absolute position detection system by DIO) (___ 1)" is selected in [Pr. PA03], CN1-25 pin will become ABST only during ABS transfer mode. (Refer to chapter 12.) | DO-1 | △ | | |
| During tough drive | MTTR | | When a tough drive is enabled in [Pr. PA20], activating the instantaneous power failure tough drive will turn on MTTR. | DO-1 | △ | △ | △ |

(2) Input signal

| Device | Symbol | Connect or pin No. | Function and application | I/O division | Control mode | | |
|--|----------------------|--------------------------------------|---|--------------|--------------|---|---|
| | | | | | P | S | T |
| Analog torque limit | TLA | CN1-27 | To use the signal in the speed control mode, enable ^{Analog} external torque limit selection) with [Pr. PD23] to [Pr. PD28]. When TLA is enabled, torque is limited in the full servo motor output torque range. Apply 0 V to +10 V DC between TLA and LG. Connect the positive terminal of the power supply to TLA. The maximum torque is generated at +10 V. (Refer to section 3.6.1 (5).) Resolution: 10 bits | Analog input | ○ | △ | |
| Analog torque command | TC | | This is used to control torque in the full servo motor output torque range. Apply 0 V to ±8 V DC between TC and LG. The maximum torque is generated at ±8 V. (Refer to section 3.6.3 (1).) The speed at ±8 V can be changed with [Pr. PC13]. | Analog input | | | ○ |
| Analog speed command | VC | CN1-2 | Apply 0 V to ±10 V DC between VC and LG. Speed set in [Pr. PC12] is provided at ±10 V. (Refer to section 3.6.2 (1).) Resolution: 14 bits or equivalent | Analog input | | ○ | |
| Analog speed limit | VLA | | Apply 0 V to ±10 V DC between VLA and LG. Speed set in [Pr. PC12] is provided at ±10 V. (Refer to section 3.6.3 (3).) | Analog input | | | ○ |
| Forward rotation pulse train Reverse rotation pulse train | PP NP PG NG | CN1-10 CN1-35 CN1-11 CN1-36 | This is used to enter a command pulse train. • For open-collector type (max. input frequency: 200 kpps) Input the forward rotation pulse train between PP and DOCOM. Input the reverse rotation pulse train between NP and DOCOM. • For differential receiver type (max. input frequency: 4 Mpps) Input the forward rotation pulse train between PG and PP. Input the reverse rotation pulse train between NG and NP. The command input pulse train form, pulse train logic, and command input pulse train filter are changed in [Pr. PA13]. | DI-2 | ○ | | |

3. SIGNALS AND WIRING

(3) Output signal

| Device | Symbol | Connect or pin No. | Function and application | I/O division | Control mode | | |
|--|-----------|--------------------|--|---------------|--------------|---|---|
| | | | | | P | S | T |
| Encoder A-phase pulse (differential line driver) | LA LAR | CN1-4 CN1-5 | These devices output pulses of encoder output set in [Pr. PA15] in the differential line driver type. In CCW rotation of the servo motor, the encoder B-phase pulse lags the encoder A-phase pulse by a phase angle of $\pi/2$. | DO-2 | ○ | ○ | ○ |
| Encoder B-phase pulse (differential line driver) | LB LBR | CN1-6 CN1-7 | The relation between rotation direction and phase difference of the A-phase and B-phase pulses can be changed with [Pr. PC19]. | | | | |
| Encoder Z-phase pulse (differential line driver) | LZ LZR | CN1-8 CN1-9 | The encoder zero-point signal is output in the differential line driver type. One pulse is output per servo motor revolution. This turns on when the zero-point position is reached. (negative logic) The minimum pulse width is about 400 μ s. For home position return using this pulse, set the creep speed to 100 r/min. or less. | DO-2 | ○ | ○ | ○ |
| Encoder Z-phase pulse (open-collector) | OP | CN1-33 | The encoder zero-point signal is output in the open-collector type. | DO-2 | ○ | ○ | ○ |
| Analog monitor 1 | MO1 | CN6-3 | This is used to output the data set in [Pr. PC14] to between MO1 and LG in terms of voltage. Resolution: 10 bits or equivalent | Analog output | ○ | ○ | ○ |
| Analog monitor 2 | MO2 | CN6-2 | This signal output the data set in [Pr. PC15] to between MO2 and LG in terms of voltage. Resolution: 10 bits or equivalent | Analog output | ○ | ○ | ○ |

(4) Communication (available in the future)

| Device | Symbol | Connect or pin No. | Function and application | I/O division | Control mode | | |
|------------|--------------------------|----------------------------------|---|--------------|--------------|---|---|
| | | | | | P | S | T |
| RS-422 I/F | SDP SDN RDP RDN | CN3-5 CN3-4 CN3-3 CN3-6 | These are terminals for RS-422 communication. | | ○ | ○ | ○ |

3. SIGNALS AND WIRING

(5) Power supply

| Device | Symbol | Connect or pin No. | Function and application | I/O division | Control mode | | |
|--------------------------------|--------|--|---|--------------|--------------|---|---|
| | | | | | P | S | T |
| Digital I/F power supply input | DICOM | CN1-20 CN1-21 | Input 24 V DC (24 V DC \pm 10% 500 mA) for I/O interface. The power supply capacity changes depending on the number of I/O interface points to be used. For sink interface, connect + of 24 V DC external power supply. For source interface, connect - of 24 V DC external power supply. | | ○ | ○ | ○ |
| Open-collector power input | OPC | CN1-12 | When inputting a pulse train in the open-collector type, supply this terminal with the positive (+) power of 24 V DC. | | | | |
| Digital I/F common | DOCOM | CN1-46 CN1-47 | Common terminal for input device such as EM2 of the servo amplifier. This is separated from LG. For sink interface, connect - of 24 V DC external power supply. For source interface, connect + of 24 V DC external power supply. | | ○ | ○ | ○ |
| 15 V DC power supply | P15R | CN1-1 | This outputs 15 V DC to between P15R and LG. This is available as power for TC, TLA, VC, or VLA. Permissible current: 30 mA | | ○ | ○ | ○ |
| Control common | LG | CN1-3 CN1-28 CN1-30 CN1-34 CN3-1 CN3-7 CN6-1 | This is a common terminal for TLA, TC, VC, VLA, FPA, FPB, OP, MO1, MO2, and P15R. Pins are connected internally. | | ○ | ○ | ○ |
| Shield | SD | Plate | Connect the external conductor of the shielded wire. | | ○ | ○ | ○ |

3. SIGNALS AND WIRING

3.6 Detailed description of signals

3.6.1 Position control mode

| POINT | | |
|---|---|---|
| <ul style="list-style-type: none"> ● Adjust the logic of a positioning module and command pulse as follows. | | |
| <ul style="list-style-type: none"> ▪ Q series/L series positioning module Pr. 23 setting | | |
| | Command pulse logic setting | |
| Signal type | Q series/L series positioning module Pr. 23 setting | MR-J4-_A servo amplifier [Pr. PA13] setting |
| Open-collector type | Positive logic | Positive logic (_ _ 0 _) |
| | Negative logic | Negative logic (_ _ 1 _) |
| Differential line driver type | Positive logic (Note) | Negative logic (_ _ 1 _) |
| | Positive logic (Note) | Positive logic (_ _ 0 _) |
| <p>Note. For Q series and L series, the logic means N-side waveform. Therefore, reverse the input pulse logic of the servo amplifier.</p> | | |
| <ul style="list-style-type: none"> ▪ F series Positioning module | | |
| | Command pulse logic setting | |
| Signal type | F series Positioning module (fixed) | MR-J4-_A servo amplifier [Pr. PA13] setting |
| Open-collector type Differential line driver type | Negative logic | Negative logic (_ _ 1 _) |

(1) Pulse train input

(a) Input pulse waveform selection

You can input command pulses in any of three different forms, and can choose positive or negative logic. Set the command pulse train form in [Pr. PA13]. Refer to section 5.2.1 for details.

(b) Connection and waveform

1) Open-collector type

Connect as follows.

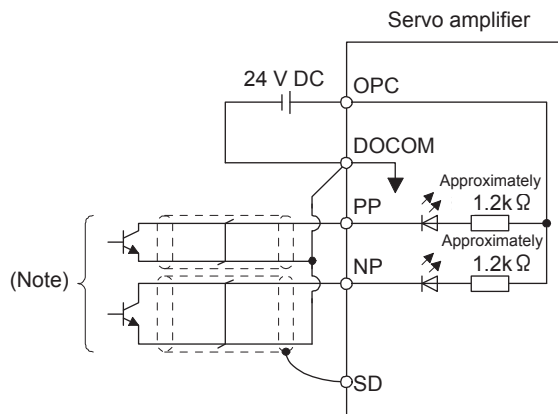

Note. Pulse train input interface is comprised of a photocoupler.

Therefore, it may malfunction since a current is reduced when connect a resistance to a pulse train signal line.

3. SIGNALS AND WIRING

The following example shows that an input waveform has been set to the negative logic and forward/reverse rotation pulse trains by setting "0 0 1 0" in [Pr. PA13].

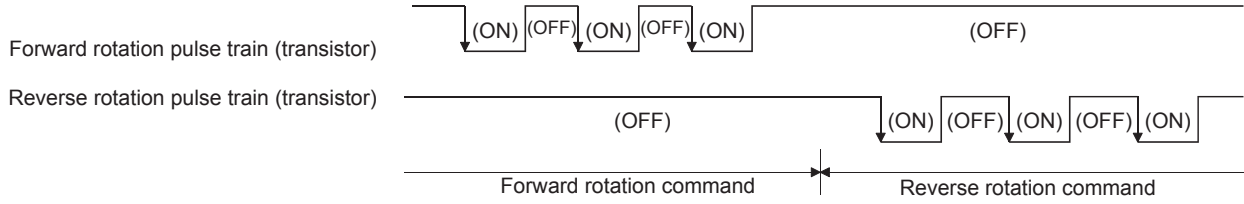

2) Differential line driver type
Connect as follows.

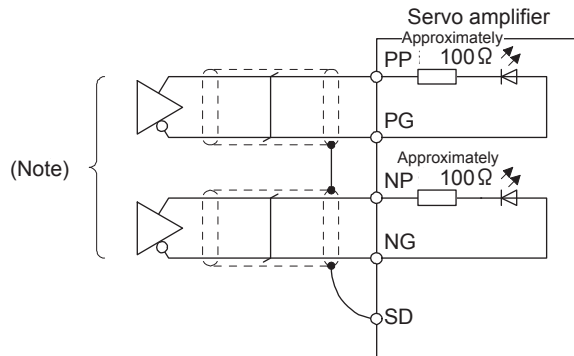

Note. Pulse train input interface is comprised of a photocoupler. Therefore, it may malfunction since a current is reduced when connect a resistance to a pulse train signal line.

The following example shows that an input waveform has been set to the negative logic and forward/reverse rotation pulse trains by setting "0 0 1 0" in [Pr. PA13]. The waveforms of PP, PG, NP, and NG are based on LG.

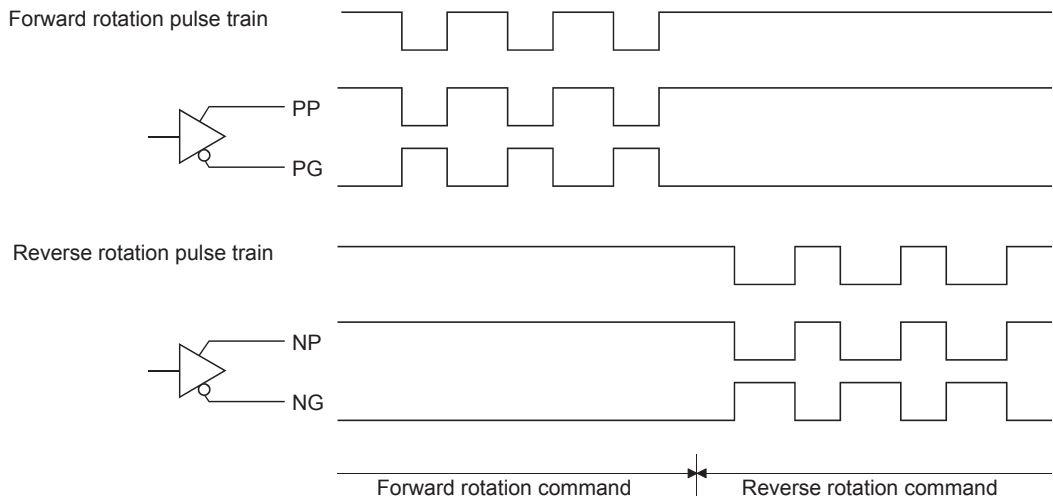

3. SIGNALS AND WIRING

(2) INP (In-position)

INP turns on when the number of droop pulses in the deviation counter falls within the preset in-position range ([Pr. PA10]). INP may turn on continuously during a low-speed operation with a large value set as the in-position range.

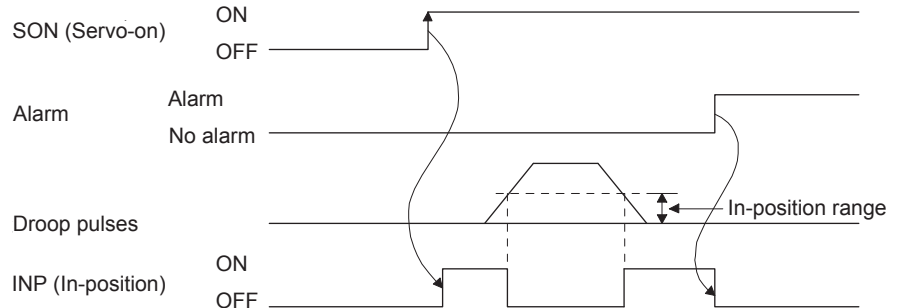

(3) RD (Ready)

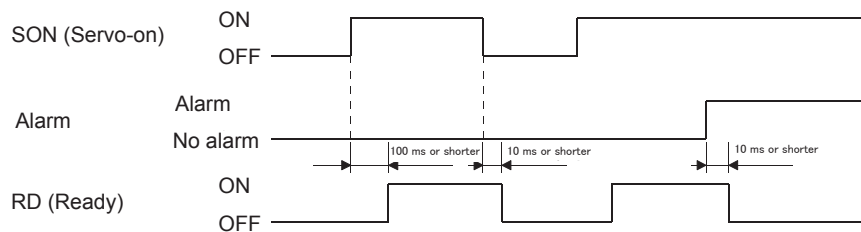

(4) Electronic gear switching

The combination of CM1 and CM2 enables you to select four different electronic gear numerators set in the parameters.

As soon as CM1/CM2 is turned on or off, the numerator of the electronic gear changes. Therefore, if a shock occurs at switching, use the position smoothing ([Pr. PB03]) to relieve the shock.

| (Note) Input device | | Electronic gear numerator |
|---------------------|-----|---------------------------|
| CM2 | CM1 | |
| 0 | 0 | Pr. PA06 |
| 0 | 1 | Pr. PC32 |
| 1 | 0 | Pr. PC33 |
| 1 | 1 | Pr. PC34 |

Note. 0: Off
1: On

3. SIGNALS AND WIRING

(5) Torque limit



Cautions

● If the torque limit is canceled during servo-lock, the servo motor may suddenly rotate according to position deviation in respect to the command position.

(a) Torque limit and torque

By setting [Pr. PA11 Forward rotation torque limit] or [Pr. PA12 Reverse rotation torque limit], torque is always limited to the maximum value during operation. A relation between the limit value and servo motor torque is as follows.

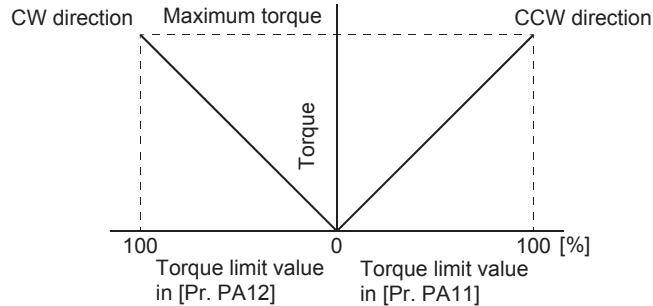

A relation between the applied voltage of TLA (Analog torque limit) and the torque limit value of the servo motor is as follows. Torque limit values will vary about 5% relative to the voltage depending on products. At the voltage of less than 0.05 V, torque may vary as it may not be limited sufficiently. Therefore, use this function at the voltage of 0.05 V or more.

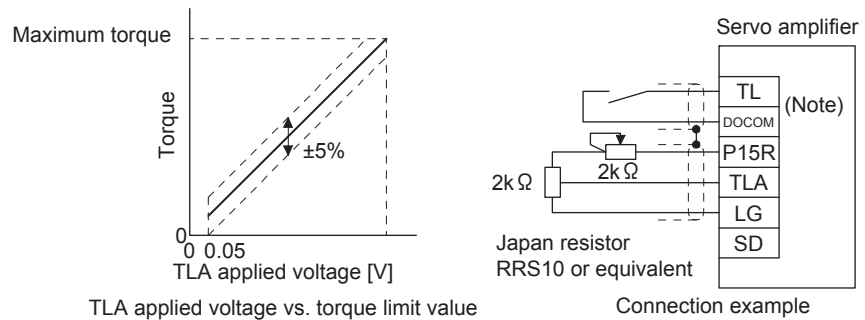

Note. This diagram is for sink I/O interface. For source I/O interface, refer to section 3.9.3.

(b) Torque limit value selection

The following shows how to select a torque limit using TL (External torque limit selection) from [Pr. PA11 Forward torque limit] or [Pr. PA12 Reverse torque limit] and TLA (Analog torque limit).

When TL1 (Internal torque limit selection) is enabled with [Pr. PD03] to [Pr. PD22], you can select [Pr. PC35 Internal torque limit 2].

However, if [Pr. PA11] and [Pr. PA12] value is less than the limit value selected by TL/TL1, [Pr. PA11] and [Pr. PA12] value will be enabled.

3. SIGNALS AND WIRING

| (Note) Input device | | Limit value status | Enabled torque limit value | |
|---------------------|----|---------------------------------|-----------------------------|-----------------------------|
| TL1 | TL | | CCW driving/CW regeneration | CW driving/CCW regeneration |
| 0 | 0 | | Pr. PA11 | Pr. PA12 |
| 0 | 1 | TLA > Pr. PA11 Pr. PA12 | Pr. PA11 | Pr. PA12 |
| | | TLA < Pr. PA11 Pr. PA12 | TLA | TLA |
| 1 | 0 | Pr. PC35 > Pr. PA11 Pr. PA12 | Pr. PA11 | Pr. PA12 |
| | | Pr. PC35 < Pr. PA11 Pr. PA12 | Pr. PC35 | Pr. PC35 |
| 1 | 1 | TLA > Pr. PC35 | Pr. PC35 | Pr. PC35 |
| | | TLA < Pr. PC35 | TLA | TLA |

Note. 0: Off

1: On

(c) TLC (Limiting torque)

TLC turns on when the servo motor torque reaches the torque limited using the forward rotation torque limit, reverse rotation torque limit or analog torque limit.

3. SIGNALS AND WIRING

3.6.2 Speed control mode

(1) Speed setting

(a) Speed command and speed

The servo motor is run at the speeds set in the parameters or at the speed set in the applied voltage of VC (Analog speed command). A relation between VC (Analog speed command) applied voltage and the servo motor speed is as follows.

Rated speed is achieved at ± 10 V with initial setting. The speed at ± 10 V can be changed with [Pr. PC12].

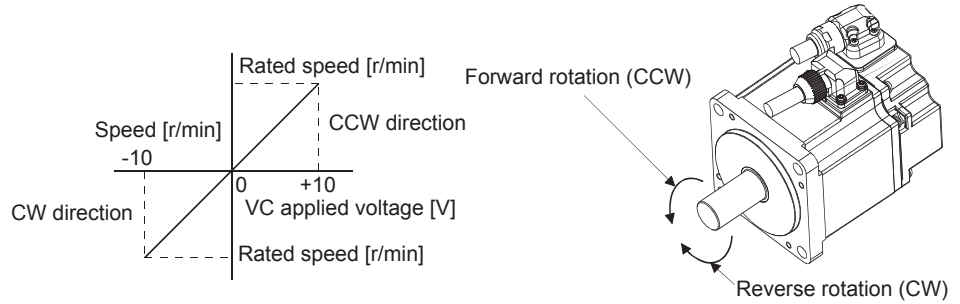

The following table indicates the rotation direction according to ST1 (Forward rotation start) and ST2 (Reverse rotation start) combination.

| (Note 1) Input device | | (Note 2) Rotation direction | | | |
|-----------------------|-----|-----------------------------|----------------------|-------------------|------------------------|
| ST2 | ST1 | VC (Analog speed command) | | | Internal speed command |
| | | Polarity: + | 0V | Polarity: - | |
| 0 | 0 | Stop (servo-lock) | Stop (servo-lock) | Stop (servo-lock) | Stop (servo-lock) |
| 0 | 1 | CCW | Stop (no servo-lock) | CW | CCW |
| 1 | 0 | CW | | CCW | CW |
| 1 | 1 | Stop (servo-lock) | Stop (servo-lock) | Stop (servo-lock) | Stop (servo-lock) |

Note 1. 0: Off
1: On

2) If the torque limit is canceled during servo-lock, the servo motor may suddenly rotate according to position deviation in respect to the command position.

Normally, connect as follows.

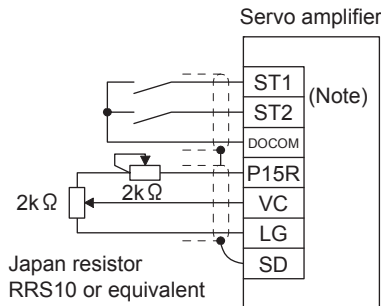

Note. This diagram is for sink I/O interface. For source I/O interface, refer to section 3.9.3.

3. SIGNALS AND WIRING

- (b) SP1 (Speed selection 1), SP2 (Speed selection 2), and speed command value
 Select any of the speed settings by the internal speed commands 1 to 3 and by VC (Analog speed command) using SP1 (Speed selection 1) and SP2 (Speed selection 2) as follows.

| (Note) Input device | | Speed command value |
|---------------------|-----|-----------------------------------|
| SP2 | SP1 | |
| 0 | 0 | VC (Analog speed command) |
| 0 | 1 | Pr. PC05 Internal speed command 1 |
| 1 | 0 | Pr. PC06 Internal speed command 2 |
| 1 | 1 | Pr. PC07 Internal speed command 3 |

Note. 0: Off
 1: On

To select VC (Analog speed command) and a speed command value of internal speed commands 1 to 7, enable SP3 (Speed selection 3) with [Pr. PD03] to [Pr. PD22].

| (Note) Input device | | | Speed command value |
|---------------------|-----|-----|-----------------------------------|
| SP3 | SP2 | SP1 | |
| 0 | 0 | 0 | VC (Analog speed command) |
| 0 | 0 | 1 | Pr. PC05 Internal speed command 1 |
| 0 | 1 | 0 | Pr. PC06 Internal speed command 2 |
| 0 | 1 | 1 | Pr. PC07 Internal speed command 3 |
| 1 | 0 | 0 | Pr. PC08 Internal speed command 4 |
| 1 | 0 | 1 | Pr. PC09 Internal speed command 5 |
| 1 | 1 | 0 | Pr. PC10 Internal speed command 6 |
| 1 | 1 | 1 | Pr. PC11 Internal speed command 7 |

Note. 0: Off
 1: On

You can change the speed during rotation. To accelerate/decelerate, set acceleration/deceleration time constant in [Pr. PC01] or [Pr. PC02].

When the internal speed commands are used to command a speed, the speed does not vary with the ambient temperature.

- (2) SA (Speed reached)

SA turns on when the servo motor speed has nearly reached the speed set to the internal speed command or analog speed command.

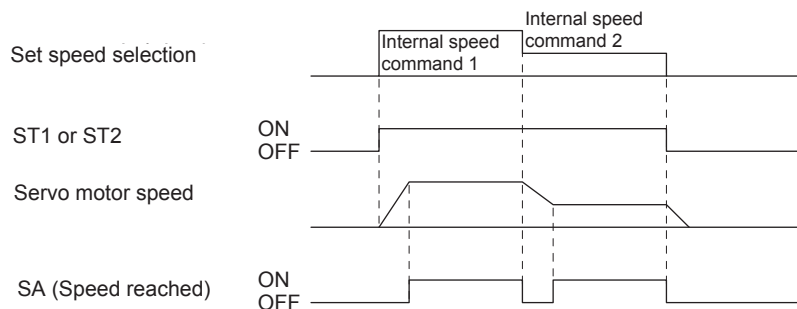

- (3) Torque limit

As in section 3.6.1 (5)

3. SIGNALS AND WIRING

3.6.3 Torque control mode

(1) Torque limit

(a) Torque command and torque

The following shows a relation between the applied voltage of TC (Analog torque command) and the torque by the servo motor.

The maximum torque is generated at ± 8 V. The speed at ± 8 V can be changed with [Pr. PC13].

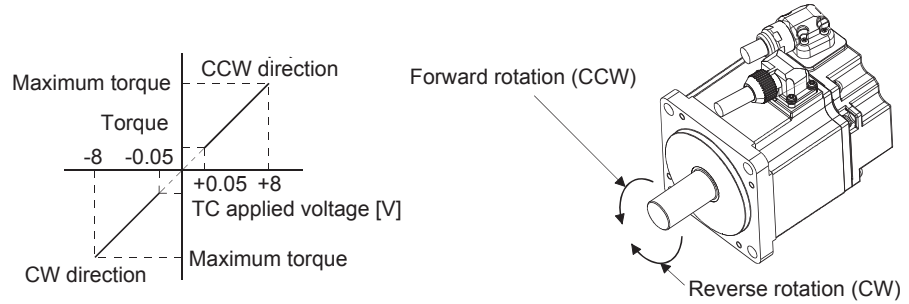

Generated torque command values will vary about 5% relative to the voltage depending on products. The torque may vary if the voltage is low (-0.05 V to +0.05 V) and the actual speed is close to the limit value. In such a case, increase the speed limit value.

The following table indicates the torque generation directions determined by RS1 (Forward rotation selection) and RS2 (Reverse rotation selection) when TC (Analog torque command) is used.

| (Note) Input device | | Rotation direction | | |
|---------------------|-----|---|--------------------------|---|
| RS2 | RS1 | TC (Analog torque command) | | |
| | | Polarity: + | 0V | Polarity: - |
| 0 | 0 | Torque is not generated. | Torque is not generated. | Torque is not generated. |
| 0 | 1 | CCW (Forward rotation in driving mode/reverse rotation in regenerative mode) | | CW (Reverse rotation in driving mode/forward rotation in regenerative mode) |
| 1 | 0 | CW (Reverse rotation in driving mode/forward rotation in regenerative mode) | | CCW (Forward rotation in driving mode/reverse rotation in regenerative mode) |
| 1 | 1 | Torque is not generated. | | Torque is not generated. |

Note. 0: Off
1: On

Normally, connect as follows.

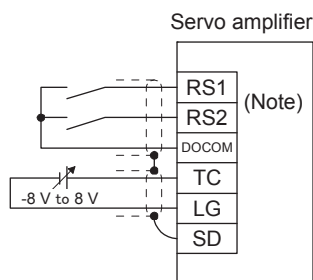

Note. This diagram is for sink I/O interface. For source I/O interface, refer to section 3.9.3.

3. SIGNALS AND WIRING

(b) Analog torque command offset

Using [Pr. PC38], the offset voltage of -9999 mV to $+9999\text{ mV}$ can be added to the TC applied voltage as follows.

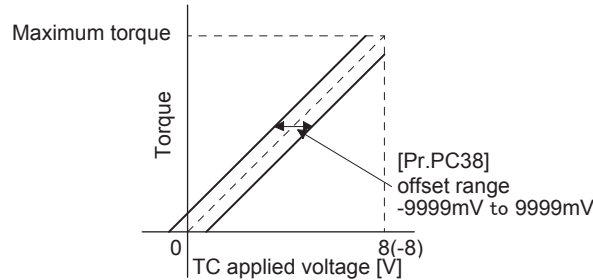

(2) Torque limit

By setting [Pr. PA11 Forward rotation torque limit] or [Pr. PA12 Reverse rotation torque limit], torque is always limited to the maximum value during operation. A relation between limit value and servo motor torque is as in section 3.6.1 (5).

Note that TLA (Analog torque limit) is unavailable.

(3) Speed limit

(a) Speed limit value and speed

The speed is limited to the values set with [Pr. PC05 Internal speed limit 0] to [Pr. PC11 Internal speed limit 7] or the value set in the applied voltage of VLA (Analog speed limit). A relation between VLA (Analog speed limit) applied voltage and the servo motor speed is as follows.

When the servo motor speed reaches the speed limit value, torque control may become unstable.

Make the set value more than 100 r/min greater than the desired speed limit value.

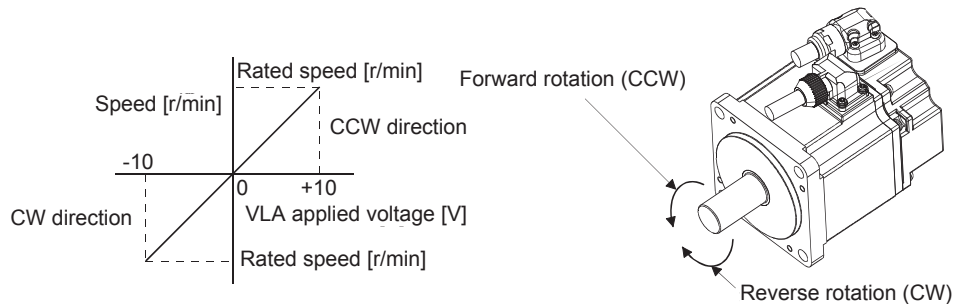

The following table indicates the limit direction according to RS1 (Forward rotation selection) and RS2 (Reverse rotation selection) combination.

| (Note) Input device | | Speed limit direction | | |
|---------------------|-----|--------------------------|-------------|------------------------|
| RS1 | RS2 | VLA (Analog speed limit) | | Internal speed command |
| | | Polarity: + | Polarity: - | |
| 1 | 0 | CCW | CW | CCW |
| 0 | 1 | CW | CCW | CW |

Note. 0: Off
1: On

3. SIGNALS AND WIRING

Normally, connect as follows.

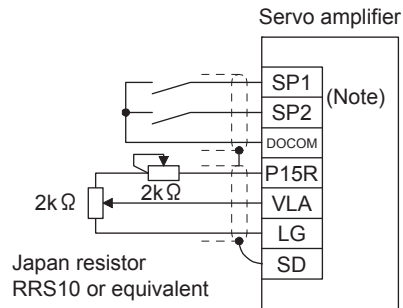

Note. This diagram is for sink I/O interface. For source I/O interface, refer to section 3.9.3.

(b) Speed limit value selection

Select any of the speed settings by the internal speed limits 1 to 7 and by VLA (Analog speed limit) using SP1 (Speed selection 1), SP2 (Speed selection 2), and SP3 (Speed selection 3) as follows.

| (Note) Input device | | | Speed limit |
|---------------------|-----|-----|---------------------------------|
| SP3 | SP2 | SP1 | |
| 0 | 0 | 0 | VLA (Analog speed limit) |
| 0 | 0 | 1 | Pr. PC05 Internal speed limit 1 |
| 0 | 1 | 0 | Pr. PC06 Internal speed limit 2 |
| 0 | 1 | 1 | Pr. PC07 Internal speed limit 3 |
| 1 | 0 | 0 | Pr. PC08 Internal speed limit 4 |
| 1 | 0 | 1 | Pr. PC09 Internal speed limit 5 |
| 1 | 1 | 0 | Pr. PC10 Internal speed limit 6 |
| 1 | 1 | 1 | Pr. PC11 Internal speed limit 7 |

Note. 0: Off
1: On

When the internal speed limits 1 to 7 are used to limit a speed, the speed does not vary with the ambient temperature.

(c) VLC (Limiting speed)

VLC turns on when the servo motor speed reaches a speed limited with internal speed limits 1 to 7 or analog speed limit.

3. SIGNALS AND WIRING

3.6.4 Position/speed control switching mode

Set " __ _ 1" in [Pr. PA01] to switch to the position/speed control switching mode. This function is not available in the absolute position detection system.

(1) LOP (control switching)

Use LOP (Control switching) to switch between the position control mode and the speed control mode with an external contact. The following shows a relation between LOP and control modes.

| (Note) LOP | Control mode |
|---------------|-----------------------|
| 0 | Position control mode |
| 1 | Speed control mode |

Note. 0: Off
1: On

You can switch the control mode in the zero speed status. To ensure safety, switch modes after the servo motor has stopped. When position control mode is switched to speed control mode, droop pulses will be reset.

If LOP is switched on/off at the speed higher than the zero speed, the control mode cannot be changed regardless of the speed. The following shows a switching timing chart.

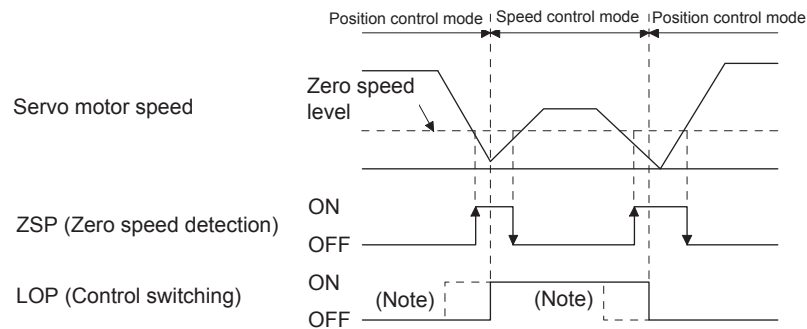

Note. When ZSP is not turned on, the control mode is not switched even if LOP is turned on/off. After LOP is turned on/off, even if ZSP is turned on, the control mode is not switched.

(2) Torque limit in position control mode

As in section 3.6.1 (5)

3. SIGNALS AND WIRING

(3) Speed setting in speed control mod

(a) Speed command and speed

The servo motor is run at the speeds set in the parameters or at the speed set in the applied voltage of VC (Analog speed command). The relation between an applied voltage of VC (Analog speed command) and servo motor speed, and the rotation direction with turning on ST1/ST2 are the same as section 3.6.2 (1) (a).

Normally, connect as follows.

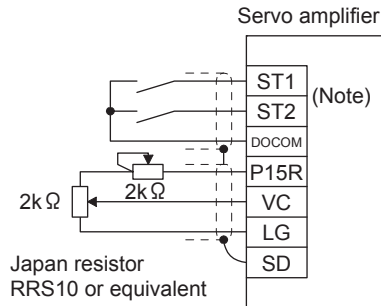

Note. This diagram is for sink I/O interface. For source I/O interface, refer to section 3.9.3.

(b) Speed command value selection

Select any of the speed settings by the internal speed commands 1 to 3 and by VC (Analog speed command) using SP1 (Speed selection 1) and SP2 (Speed selection 2) as follows.

| (Note) Input device | | Speed command value |
|---------------------|-----|-----------------------------------|
| SP2 | SP1 | |
| 0 | 0 | VC (Analog speed command) |
| 0 | 1 | Pr. PC05 Internal speed command 1 |
| 1 | 0 | Pr. PC06 Internal speed command 2 |
| 1 | 1 | Pr. PC07 Internal speed command 3 |

Note. 0: Off
1: On

To select VC (Analog speed command) and a speed command value of internal speed commands 1 to 7, enable SP3 (Speed selection 3) with [Pr. PD03] to [Pr. PD22].

| (Note) Input device | | | Speed command value |
|---------------------|-----|-----|-----------------------------------|
| SP3 | SP2 | SP1 | |
| 0 | 0 | 0 | VC (Analog speed command) |
| 0 | 0 | 1 | Pr. PC05 Internal speed command 1 |
| 0 | 1 | 0 | Pr. PC06 Internal speed command 2 |
| 0 | 1 | 1 | Pr. PC07 Internal speed command 3 |
| 1 | 0 | 0 | Pr. PC08 Internal speed command 4 |
| 1 | 0 | 1 | Pr. PC09 Internal speed command 5 |
| 1 | 1 | 0 | Pr. PC10 Internal speed command 6 |
| 1 | 1 | 1 | Pr. PC11 Internal speed command 7 |

Note. 0: Off
1: On

You can change the speed during rotation. Acceleration/deceleration is performed with the setting values of [Pr. PC01] and [Pr. PC02].

When the internal speed commands 1 to 7 are used to command a speed, the speed does not vary with the ambient temperature.

3. SIGNALS AND WIRING

- (c) SA (Speed reached)
As in section 3.6.2 (2)

3.6.5 Speed/torque control switching mode

Set " ___ 3" in [Pr. PA01] to switch to the speed/torque control switching mode.

(1) LOP (control switching)

Use LOP (Control switching) to switch between the speed control mode and the torque control mode with an external contact. The following shows a relation between LOP and control modes.

| (Note) LOP | Control mode |
|---------------|---------------------|
| 0 | Speed control mode |
| 1 | Torque control mode |

Note. 0: Off
1: On

The control mode may be switched at any time. The following shows a switching timing chart.

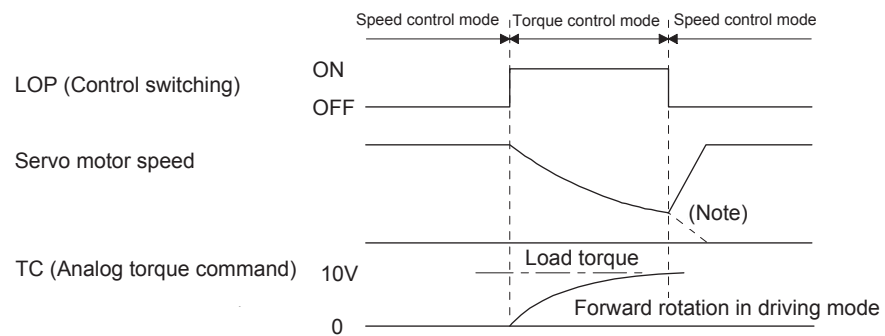

Note. When ST1 (Forward rotation start) and ST2 (Reverse rotation start) are switched off as soon as a mode is switched to the speed control, the servo motor comes to a stop according to the deceleration time constant. A shock may occur at switching control modes.

- (2) Speed setting in speed control mode
As in section 3.6.2 (1)

- (3) Torque limit in speed control mode
As in section 3.6.1 (5)

(4) Speed limit in torque control mode

(a) Speed limit value and speed

The speed is limited to the limit value of the parameter or the value set in the applied voltage of VLA (Analog speed limit).

A relation between the VLA (Analog speed limit) applied voltage and the limit value is as in section 3.6.3 (3) (a).

3. SIGNALS AND WIRING

Normally, connect as follows.

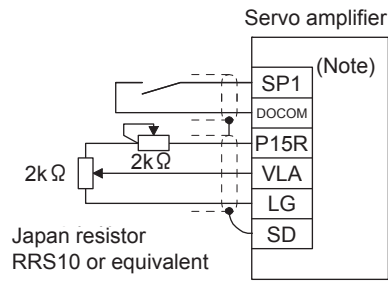

Note. This diagram is for sink I/O interface. For source I/O interface, refer to section 3.9.3.

(b) Speed limit value selection

Select any of the speed settings by the internal speed limit 1 and by VLA (Analog speed limit) using SP1 (Speed selection 1) as follows.

| (Note) Input device | Speed command value |
|---------------------|---------------------------------|
| SP1 | |
| 0 | VLA (Analog speed limit) |
| 1 | Pr. PC05 Internal speed limit 1 |

Note. 0: Off
1: On

You can change the speed during rotation. To accelerate/decelerate, set acceleration/deceleration time constant in [Pr. PC01] or [Pr. PC02].

When the internal speed command 1 is used to command a speed, the speed does not vary with the ambient temperature.

(c) VLC (Limiting speed)

As in section 3.6.3 (3) (c)

(5) Torque control in torque control mode

As in section 3.6.3 (1)

(6) Torque limit in torque control mode

As in section 3.6.3 (2)

3. SIGNALS AND WIRING

3.6.6 Torque/position control switching mode

Set " ___ 5" in [Pr. PA01] to switch to the torque/position control switching mode.

(1) LOP (control switching)

Use LOP (Control switching) to switch between the torque control mode and the position control mode with an external contact. The following shows a relation between LOP and control modes.

| (Note) LOP | Control mode |
|---------------|-----------------------|
| 0 | Torque control mode |
| 1 | Position control mode |

Note. 0: Off
1: On

You can switch the control mode in the zero speed status. To ensure safety, switch modes after the servo motor has stopped. When position control mode is switched to torque control mode, droop pulses will be reset.

If LOP is switched on/off at the speed higher than the zero speed, the control mode cannot be changed regardless of the speed. The following shows a switching timing chart.

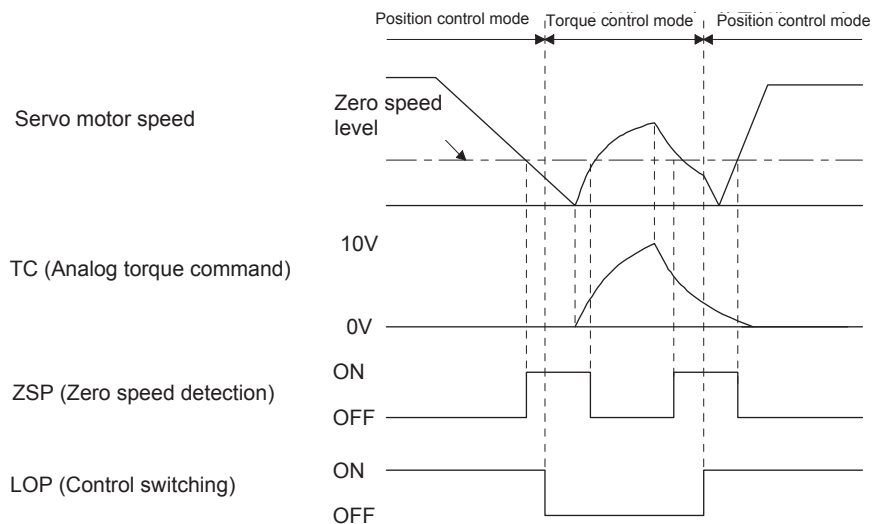

- (2) Speed limit in torque control mode
As in section 3.6.3 (3)
- (3) Torque control in torque control mode
As in section 3.6.3 (1)
- (4) Torque limit in torque control mode
As in section 3.6.3 (2)
- (5) Torque limit in position control mode
As in section 3.6.1 (5)

3. SIGNALS AND WIRING

3.7 Forced stop deceleration function

| POINT |
|--|
| ●When alarms not related to the forced stop function occur, control of motor deceleration can not be guaranteed. (Refer to chapter 8.) |
| ●In the torque control mode, the forced stop deceleration function is not available. |

3.7.1 Forced stop deceleration function (SS1)

When EM2 is turned off, dynamic brake will start to stop the servo motor after forced stop deceleration. During this sequence, the display shows [AL. E6 Servo forced stop warning].

During normal operation, do not use EM2 (Forced stop 2) to alternate stop and run. The the servo amplifier life may be shortened.

(1) Connection diagram

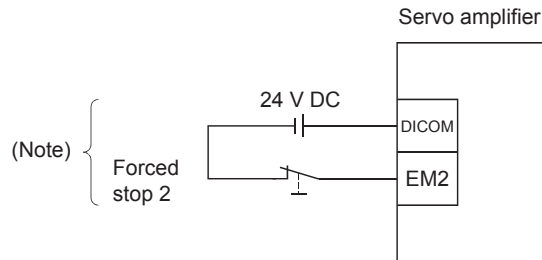

Note. This diagram is for sink I/O interface. For source I/O interface, refer to section 3.9.3.

3. SIGNALS AND WIRING

(2) Timing chart

| POINT | |
|---|-------------------------------------|
| ● When LSP/LSN is turned on during a forced stop deceleration, the motor will stop depending on the setting of [Pr. PD30] as follows. | |
| [Pr. PD30] | Stop system |
| ___ 0 | Switching to sudden stop |
| ___ 1 | Continuing forced stop deceleration |

When EM2 (Forced stop 2) turns off, the motor will decelerate according to [Pr. PC51 Forced stop deceleration time constant]. Once the motor speed is below [Pr. PC17 Zero speed], base power is cut and the dynamic brake activates.

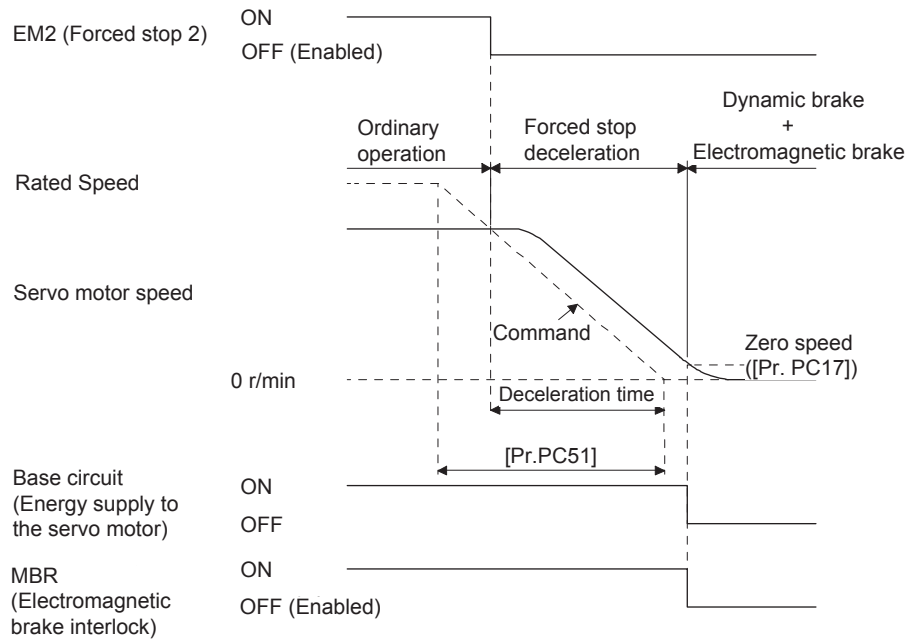

3. SIGNALS AND WIRING

3.7.2 Base circuit shut-off delay time function

The base circuit shut-off delay time function is used to maintain power at the motor for a specified time delay after a forced stop activation (EM2 goes off). The time between completion of EM2 (Forced stop 2) or activation of MBR (Electromagnetic brake interlock) due to an alarm occurrence, and the time at which the base is cut, is the base cut delay time and is set by [Pr. PC16].

(1) Timing chart

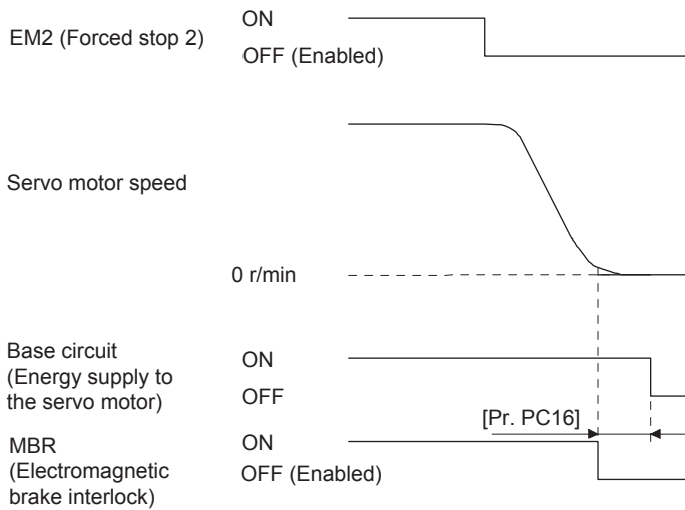

When EM2 (Forced stop 2) turns off or an alarm occurs during driving, the servo motor will decelerate based on the deceleration time constant. MBR (Electromagnetic brake interlock) will turn off, and then after the delay time set in [Pr. PC16], the servo amplifier will be base circuit shut-off status.

(2) Adjustment

While the servo motor is stopped, turn off EM2 (Forced stop 2), adjust the base circuit shut-off delay time in [Pr. PC16], and set the value to approximately 1.5 times of the smallest delay time in which the servo motor shaft does not freefall.

3. SIGNALS AND WIRING

3.7.3 Vertical axis freefall prevention function

The vertical axis freefall prevention function avoids machine damage by pulling up the shaft slightly like the following case.

When the servo motor is used for operating vertical axis, the servo motor electromagnetic brake and the base circuit shut-off delay time function avoid dropping axis at forced stop. However, the functions may not avoid dropping axis a few μm due to the backlash of the servo motor electromagnetic brake.

The vertical axis freefall prevention function is enabled with the following conditions.

- Other than "0" is set to [Pr. PC54 Vertical axis freefall prevention compensation amount].
- The servo motor speed decelerates lower than the value of zero speed by turning off EM2 (Forced stop 2) or by an alarm occurrence.
- The base circuit shut-off delay time function is enabled.

(1) Timing chart

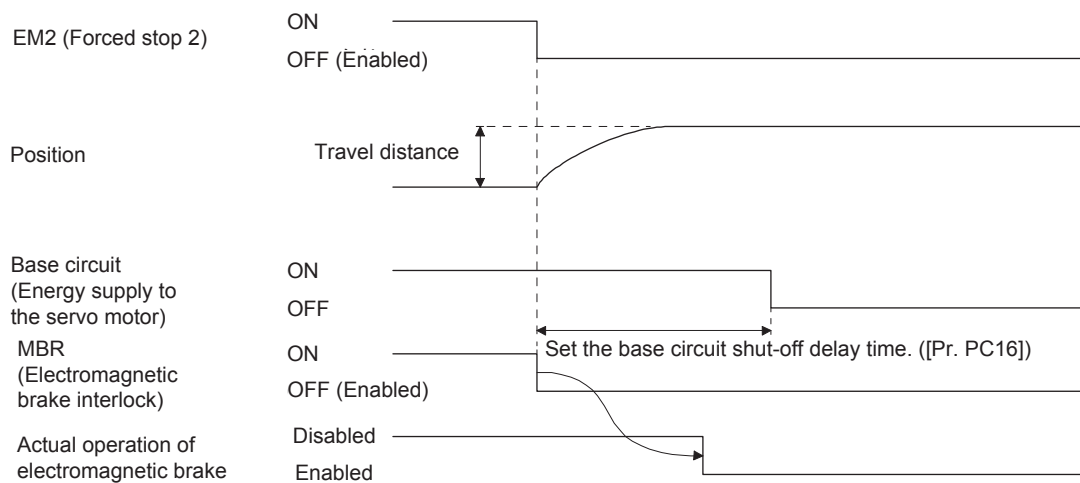

(2) Adjustment

- Set the freefall prevention compensation amount in [Pr. PC54].
- While the servo motor is stopped, turn off the EM2 (Forced stop 2). Adjust the base circuit shut-off delay time in [Pr. PC16] in accordance with the travel distance ([Pr. PC54]). Adjust it considering the freefall prevention compensation amount by checking the servo motor speed, torque ripple, etc.

3.7.4 Residual risks of the forced stop function (EM2)

- (1) The forced stop function is not available for alarms that activate the dynamic brake when the alarms occur.
- (2) When an alarm that activates the dynamic brake during forced stop deceleration occurs, the braking distance until the servo motor stops will be longer than that of normal forced stop deceleration without the dynamic brake.
- (3) If STO is turned off during forced stop deceleration, [AL.63 STO timing error] will occur.

3. SIGNALS AND WIRING

3.8 Alarm occurrence timing chart

| | | |
|---|----------|---|
|  | Cautions | <ul style="list-style-type: none"> ● When an alarm has occurred, remove its cause, make sure that the operation signal is not being input, ensure safety, and reset the alarm before restarting operation. |
|---|----------|---|

| | |
|-------|---|
| POINT | <ul style="list-style-type: none"> ● In the torque control mode, the forced stop deceleration function is not available. |
|-------|---|

To deactivate an alarm, cycle the control circuit power, push the "SET" button in the current alarm window, or cycle the RES (Reset) However, the alarm cannot be deactivated unless its cause is removed.

3.8.1 When you use the forced stop deceleration function

| | |
|-------|--|
| POINT | <ul style="list-style-type: none"> ● To enable the function, set "2 ___ (initial value)" in [Pr. PA04]. |
|-------|--|

(1) When the forced stop deceleration function is enabled

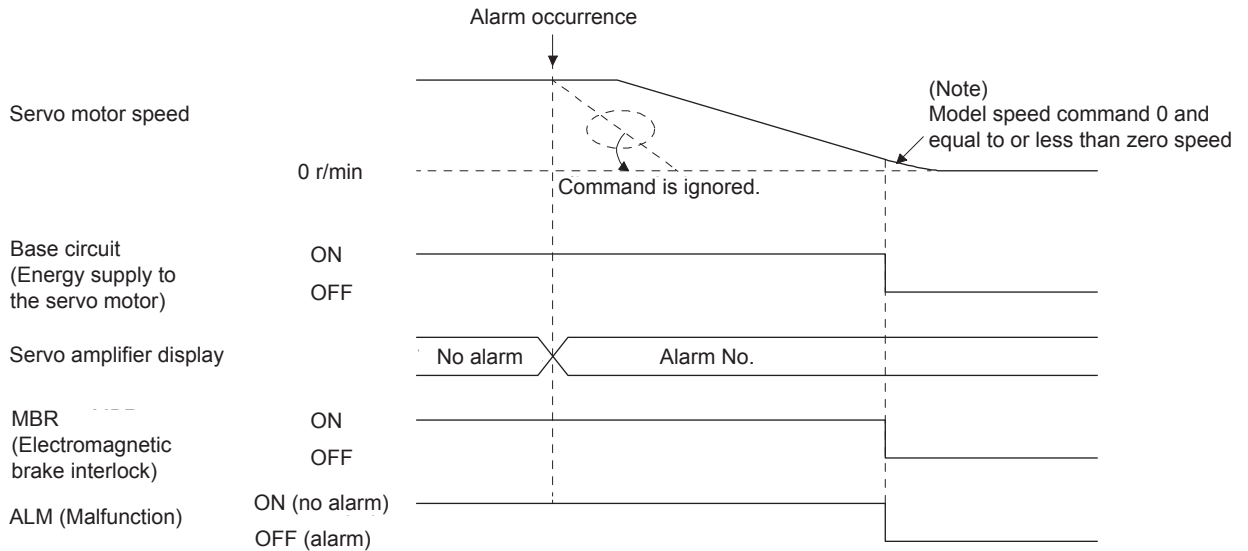

Note. The model speed command is a speed command generated in the servo amplifier for forced stop deceleration of the servo motor.

3. SIGNALS AND WIRING

(2) When the forced stop deceleration function is not enabled

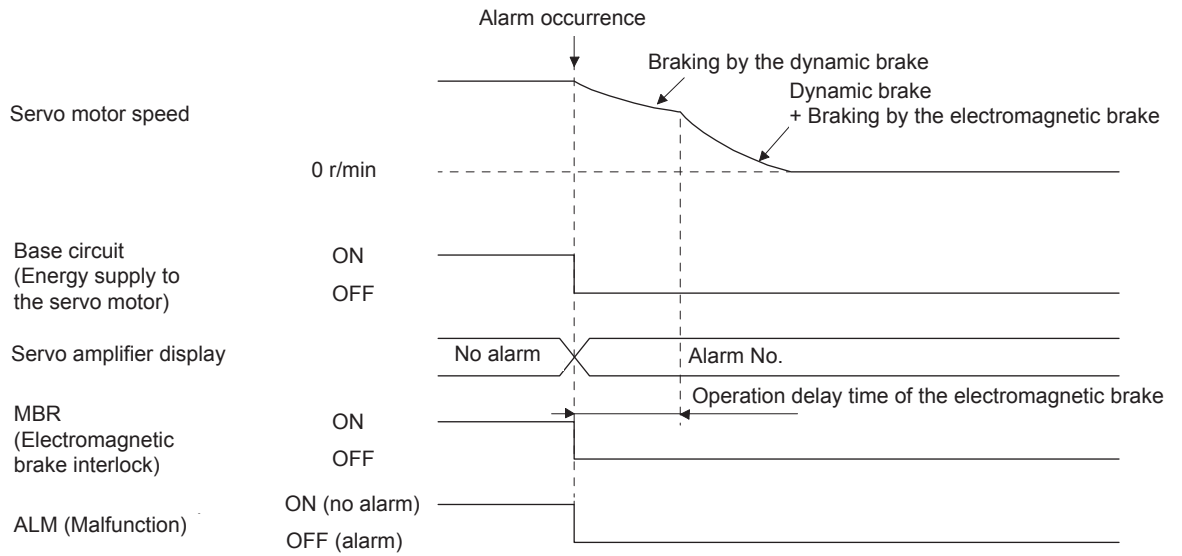

3.8.2 When you do not use the forced stop deceleration function

| | |
|-------|---|
| POINT | |
| | ● To disable the function, set "0 _ _ _" in [Pr. PA04]. |

The operation status during an alarm is the same as section 3.8.1 (2).

3. SIGNALS AND WIRING

3.9 Interfaces

3.9.1 Internal connection diagram

POINT

● Refer to section 13.3.1 for the CN8 connector.

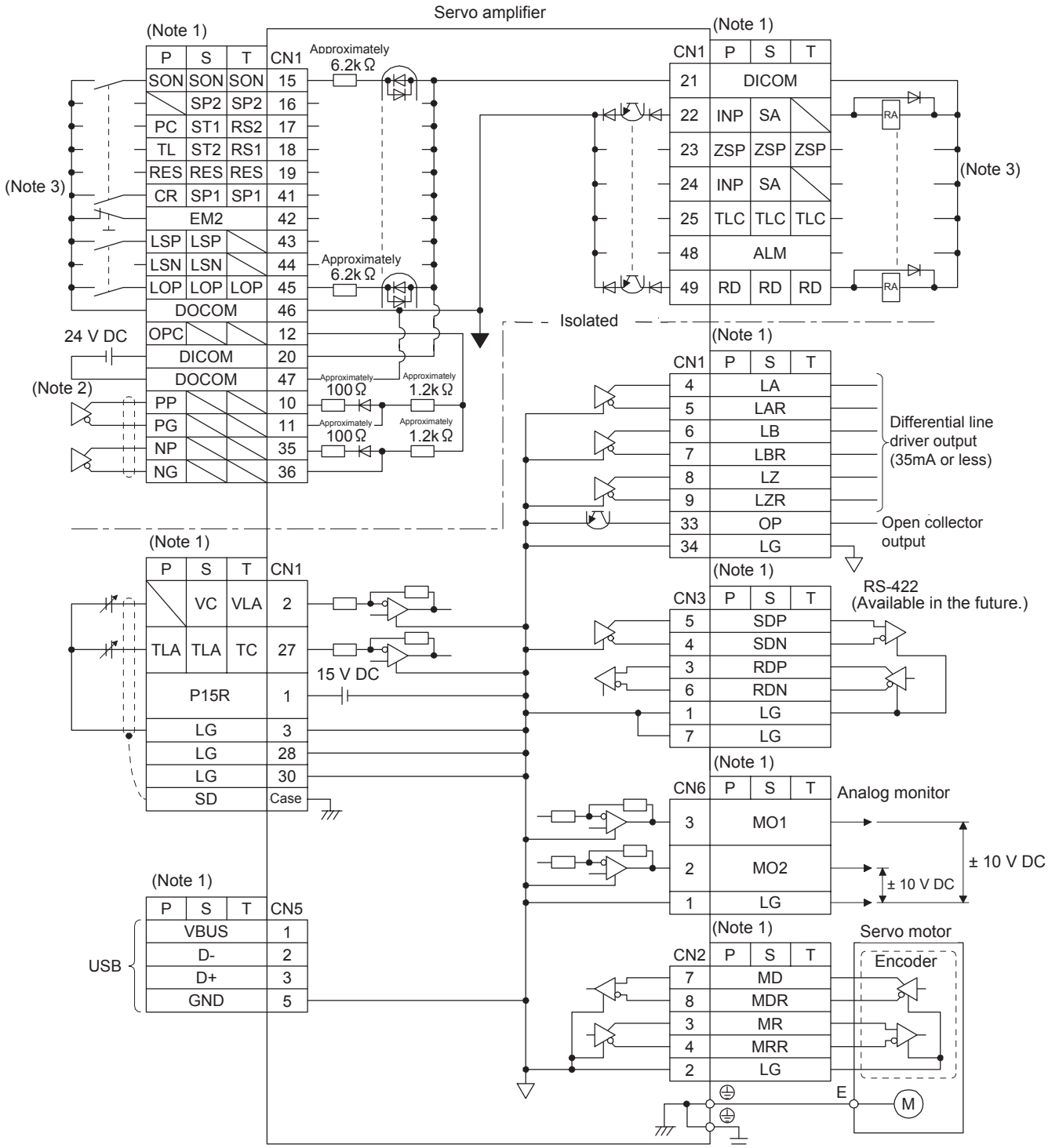

3. SIGNALS AND WIRING

- Note 1. P: position control mode, S: speed control mode, T: torque control mode
 2. This is for the differential line driver pulse train input. For the open-collector pulse train input, connect as follows.

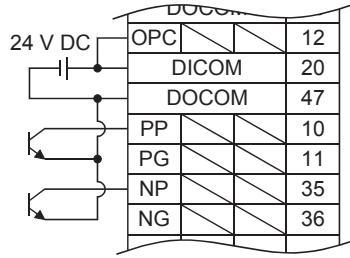

3. This diagram is for sink I/O interface. For source I/O interface, refer to section 3.9.3.

3.9.2 Detailed description of interfaces

This section provides the details of the I/O signal interfaces (refer to the I/O division in the table) given in section 3.5. Refer to this section and make connection with the external device.

(1) Digital input interface DI-1

Turn on/off the input signal with a relay or open-collector transistor. The following is a connection diagram for sink input. Refer to section 3.9.3 for source input.

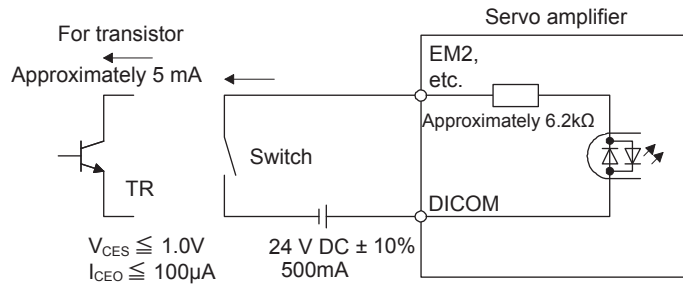

(2) Digital output interface DO-1

A lamp, relay or photocoupler can be driven. Install a diode (D) for an inductive load, or install an inrush current suppressing resistor (R) for a lamp load.

(Rated current: 40 mA or less, maximum current: 50 mA or less, inrush current: 100 mA or less) A maximum of 2.6 V voltage drop occurs in the servo amplifier.

The following shows a connection diagram for sink output. Refer to section 3.9.3 for source output.

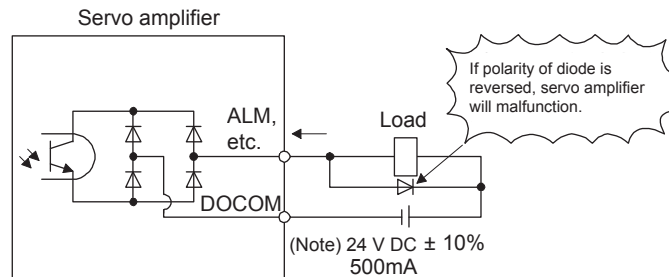

Note. If the voltage drop (maximum of 2.6 V) interferes with the relay operation, apply high voltage (maximum of 26.4 V) from external source.

3. SIGNALS AND WIRING

(3) Pulse train input interface DI-2

Give a pulse train signal in the differential line driver type or open-collector type.

(a) Differential line driver type

1) Interface

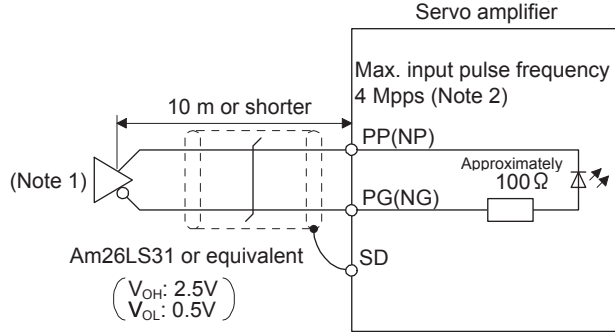

- Note 1. Pulse train input interface is comprised of a photocoupler. Therefore, it may malfunction since a current is reduced when connect a resistance to a pulse train signal line.
2. When the input pulse frequency is 4 Mpps, set [Pr. PA13] to "_ 0 _".

2) Input pulse condition

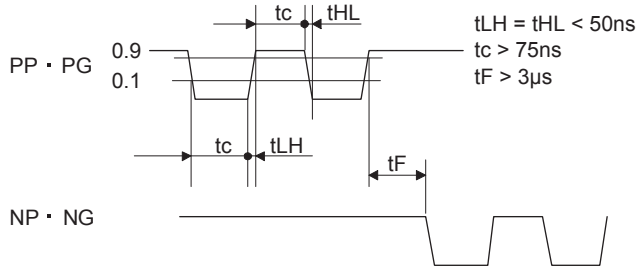

(b) Open-collector type

1) Interface

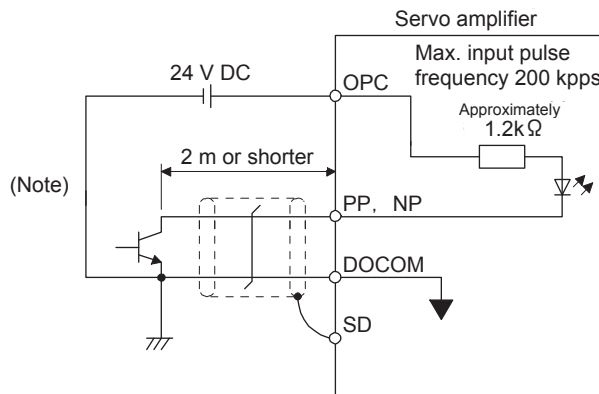

- Note. Pulse train input interface is comprised of a photocoupler. Therefore, it may malfunction since a current is reduced when connect a resistance to a pulse train signal line.

3. SIGNALS AND WIRING

2) Input pulse condition

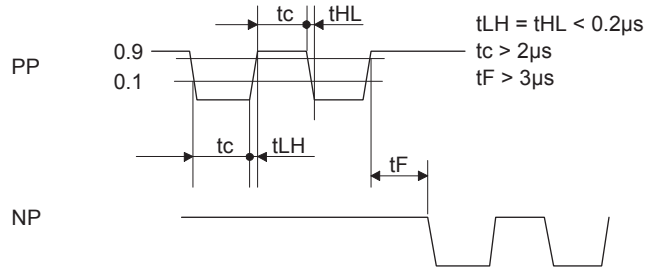

(4) Encoder output pulse DO-2

- (a) Open-collector type Interfaces

Maximum sink current: 35 mA

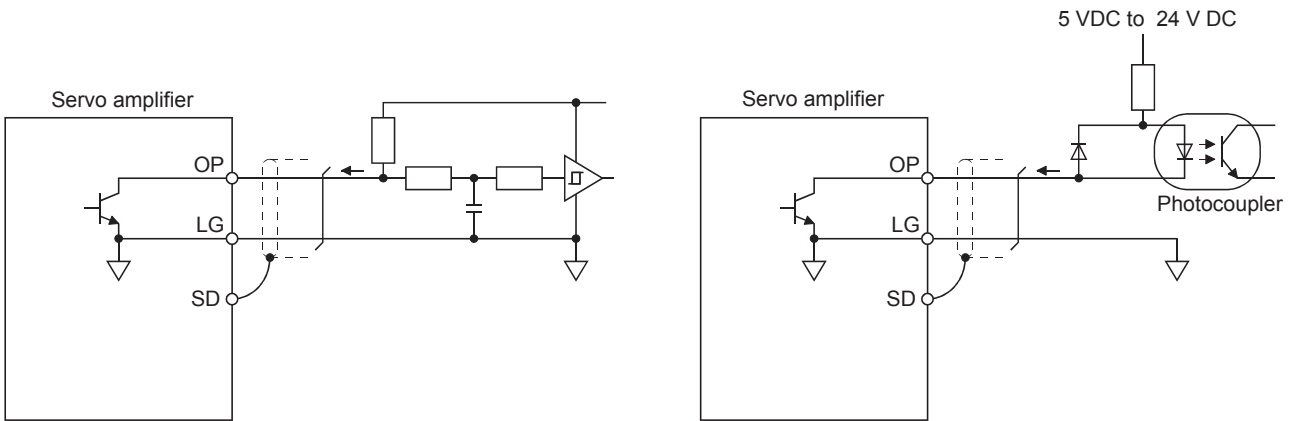

- (b) Differential line driver type

- 1) Interface

Maximum output current: 35 mA

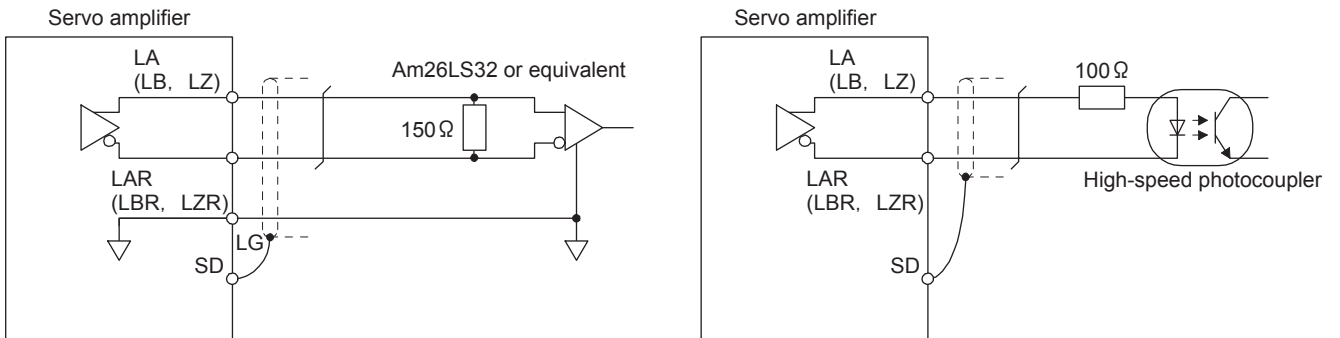

3. SIGNALS AND WIRING

2) Output pulse

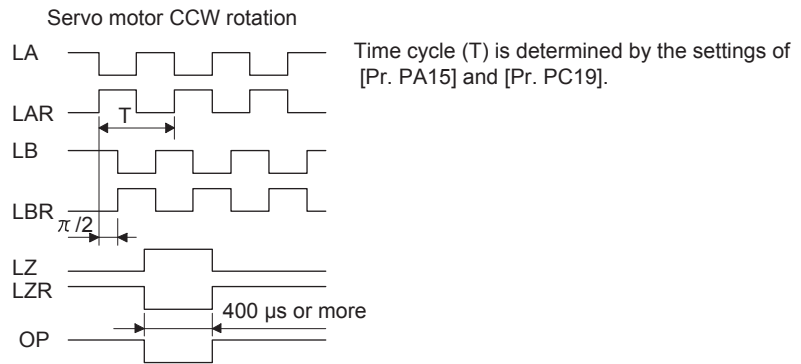

- (5) Analog input
 Input impedance
 10 kΩ to 12 kΩ

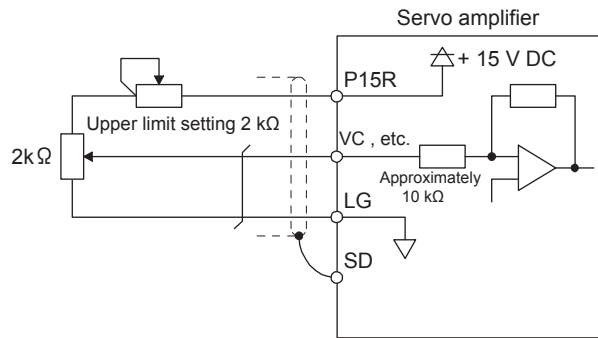

- (6) Analog output

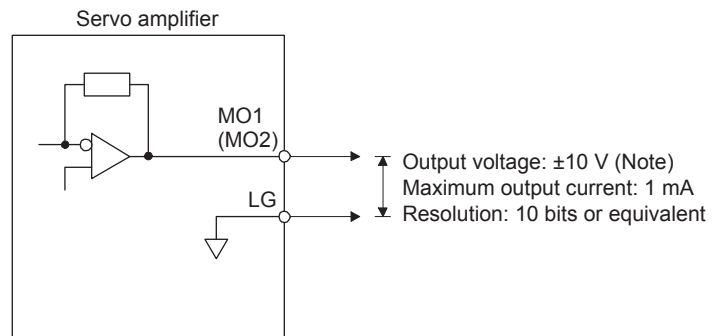

Note. Output voltage range varies depending on the monitored signal.

3. SIGNALS AND WIRING

3.9.3 Source I/O interfaces

In this servo amplifier, source type I/O interfaces can be used. In this case, all DI-1 input signals and DO-1 output signals are of source type. Perform wiring according to the following interfaces.

(1) Digital input interface DI-1

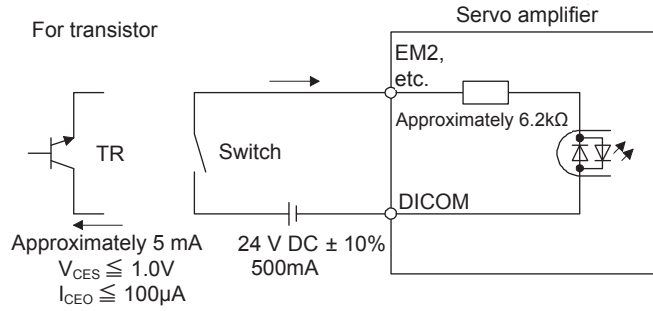

(2) Digital output interface DO-1

A maximum of 2.6 V voltage drop occurs in the servo amplifier.

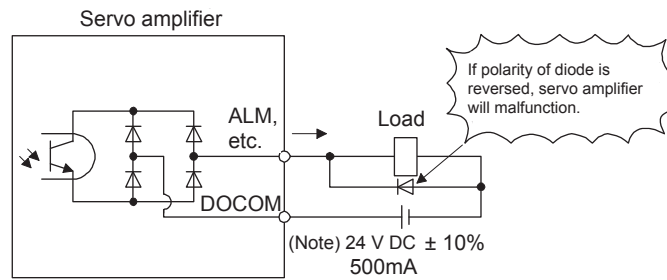

Note. If the voltage drop (maximum of 2.6 V) interferes with the relay operation, apply high voltage (maximum of 26.4 V) from external source.

3. SIGNALS AND WIRING

3.10 Servo motor with an electromagnetic brake

3.10.1 Safety precautions



Cautions

- Configure an electromagnetic brake circuit so that it is activated also by an external EMG stop switch.

Contacts must be opened when ALM (Malfunction) or MBR (Electromagnetic brake interlock) turns off. Contacts must be opened with the EMG stop switch.

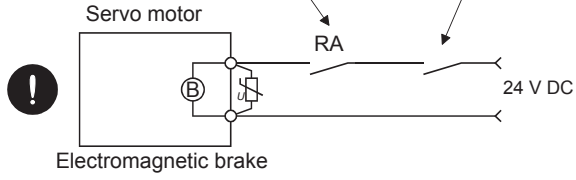

- The electromagnetic brake is provided for holding purpose and must not be used for ordinary braking.
- Before operating the servo motor, be sure to confirm that the electromagnetic brake operates properly.
- Do not use the 24 V DC interface power supply for the electromagnetic brake. Always use the power supply designed exclusively for the electromagnetic brake. Otherwise, it may cause a malfunction.

| POINT |
|--|
| <ul style="list-style-type: none"> ● Refer to the Servo Motor Instruction Manual (Vol. 3) for specifications such as the power supply capacity and operation delay time of the electromagnetic brake. ● Refer to the Servo Motor Instruction Manual (Vol. 3) or section 11.19 for the selection of a surge absorber for the electromagnetic brake. |

Note the following when the servo motor with an electromagnetic brake is used.

- 1) The brake will operate when the power (24 V DC) turns off.
- 2) The status is base circuit shut-off during RES (Reset) on. When you use the motor in vertical axis system, use MBR (Electromagnetic brake interlock).
- 3) Turn off SON (Servo-on) after the servo motor stopped.

(1) Connection diagram

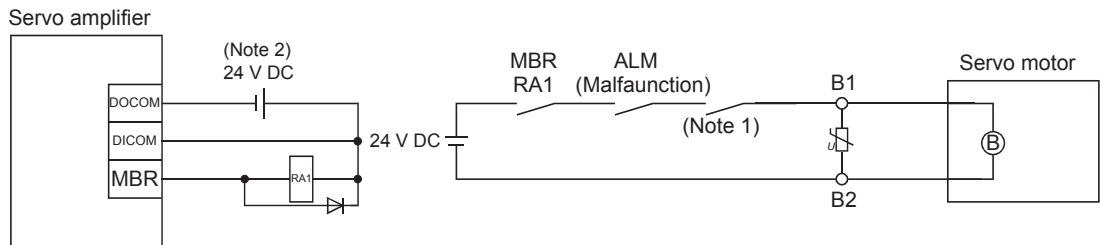

- Note 1. Create the circuit in order to shut off by interlocking with the emergency stop switch.
 Note 2. Do not use the 24 V DC interface power supply for the electromagnetic brake.

3. SIGNALS AND WIRING

(2) Setting

- (a) Enable MBR (Electromagnetic brake interlock) with [Pr. PD03] to [Pr. PD22].
- (b) In [Pr. PC16 Electromagnetic brake sequence output], set the time delay (T_b) from electromagnetic brake operation to base circuit shut-off at a servo-off as in the timing chart in section 3.10.2 (1).

3.10.2 Timing chart

(1) When you use the forced stop deceleration function

POINT

● To enable the function, set "2 _ _ _ (initial value)" in [Pr. PA04].

(a) SON (Servo-on) on/off

When SON (Servo-on) is turned off, the servo lock will be released after T_b [ms], and the servo motor will coast. If the electromagnetic brake is enabled during servo-lock, the brake life may be shorter. Therefore, set T_b about 1.5 times of the minimum delay time where the moving part will not drop down for a vertical axis system, etc.

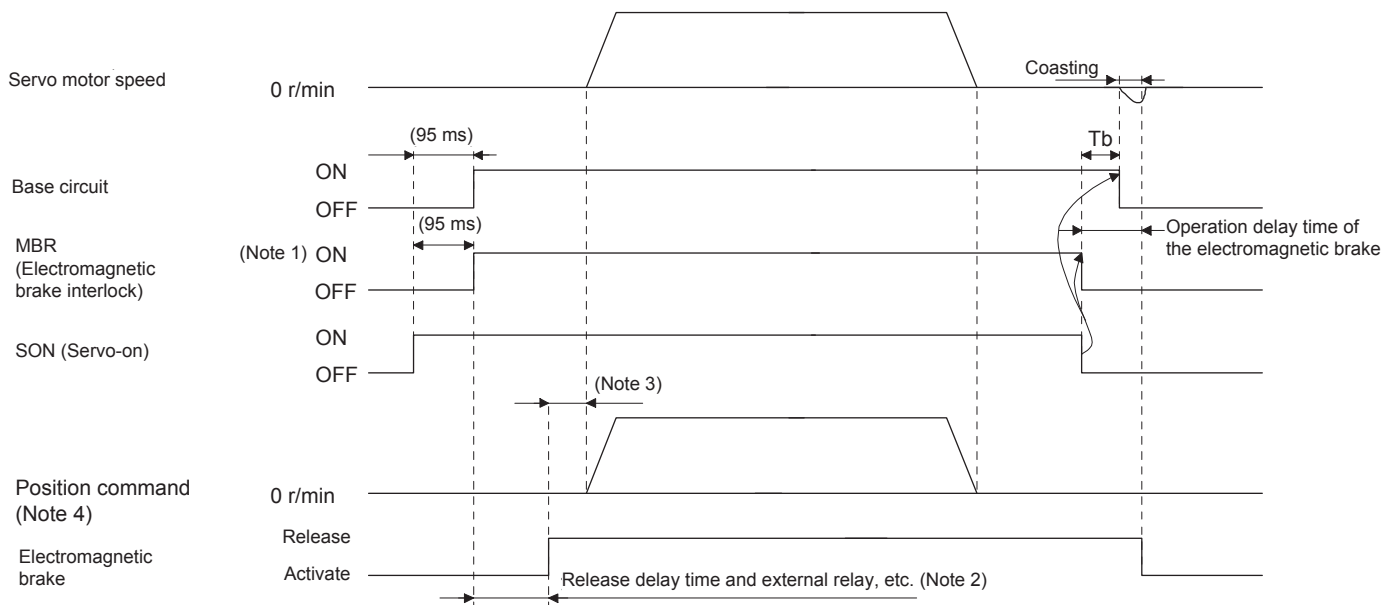

Note 1. ON : Electromagnetic brake is not activated.
 OFF: Electromagnetic brake is activated.

- 2. Electromagnetic brake is released after delaying for the release delay time of electromagnetic brake and operation time of external circuit relay. For the release delay time of electromagnetic brake, refer to the Servo Motor Instruction Manual (Vol. 3).
- 3. Give a position command after the electromagnetic brake is released.
- 4. In position control mode

3. SIGNALS AND WIRING

(b) Forced stop 2 on/off

| |
|---|
| POINT |
| ● In the torque control mode, the forced stop deceleration function is not available. |

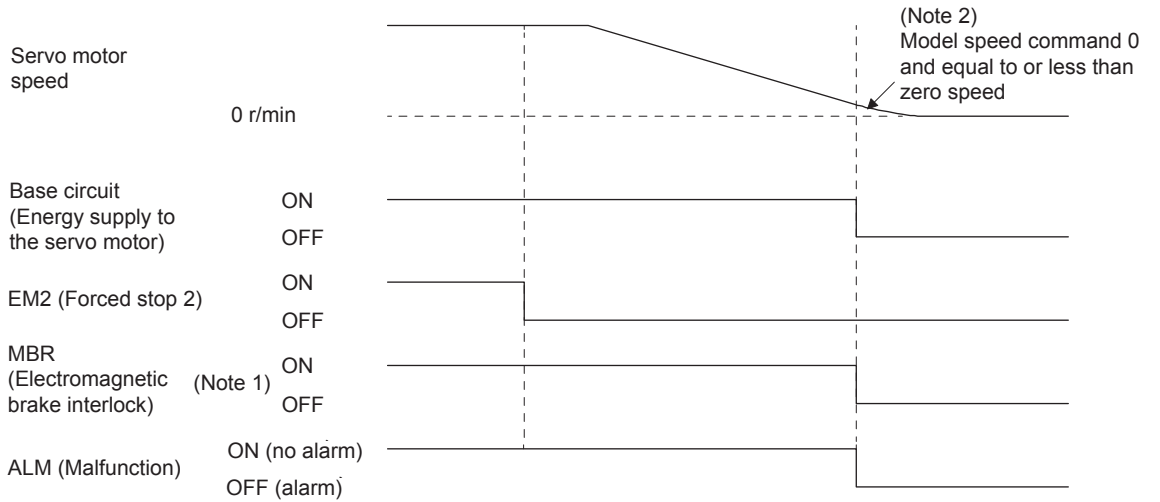

Note 1. ON : Electromagnetic brake is not activated.
OFF: Electromagnetic brake is activated.

2. The model speed command is a speed command generated in the servo amplifier for forced stop deceleration of the servo motor.

(c) Alarm occurrence

The operation status during an alarm is the same as section 3.8.

(d) Both main and control circuit power supplies off

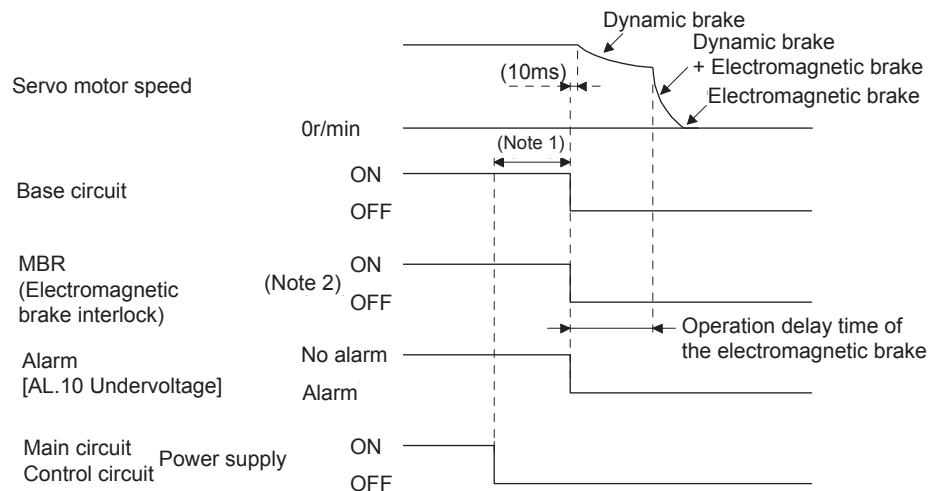

Note 1. Variable according to the operation status.
2. ON : Electromagnetic brake is not activated.
OFF: Electromagnetic brake is activated.

3. SIGNALS AND WIRING

(e) Main circuit power supply off during control circuit power supply on

POINT
 ● In the torque control mode, the forced stop deceleration function is not available.

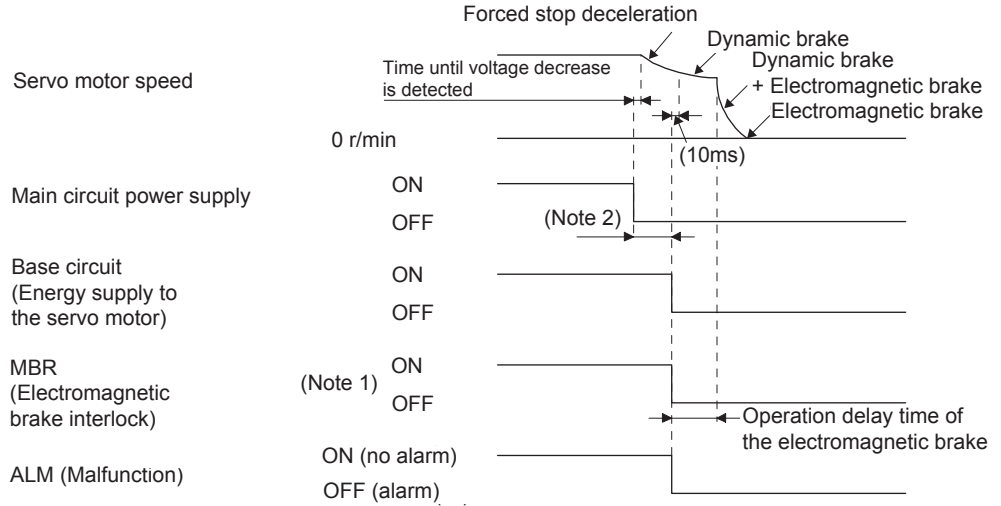

Note 1. ON : Electromagnetic brake is not activated.
 OFF: Electromagnetic brake is activated.
 2. Variable according to the operation status.

(2) When you do not use the forced stop deceleration function

POINT
 ● To disable the function, set "0 ___" in [Pr. PA04].

(a) SON (Servo-on) on/off
 It is the same as (1) (a) in this section.

(b) EM1 (Forced stop 1) on/off

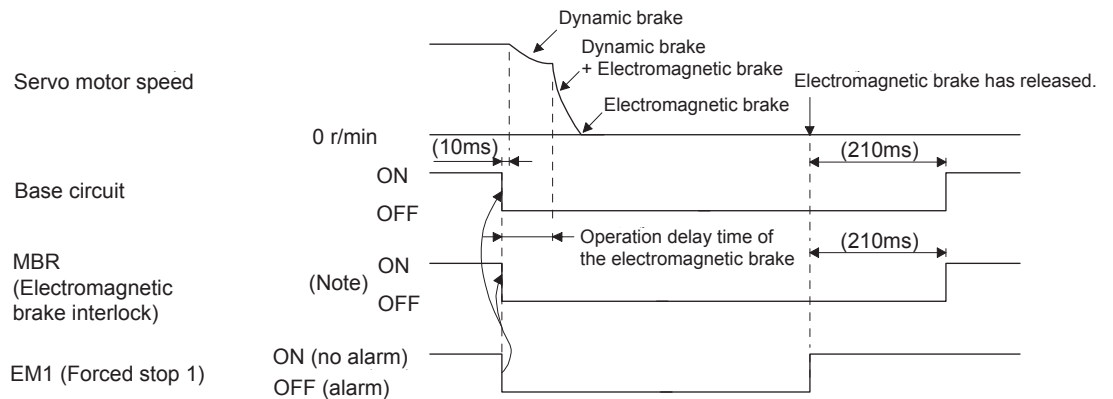

Note. ON : Electromagnetic brake is not activated.
 OFF: Electromagnetic brake is activated.

3. SIGNALS AND WIRING

(c) Alarm occurrence

The operation status during an alarm is the same as section 3.8.

(d) Both main and control circuit power supplies off

It is the same as (1) (d) in this section.

(e) Main circuit power supply off during control circuit power supply on

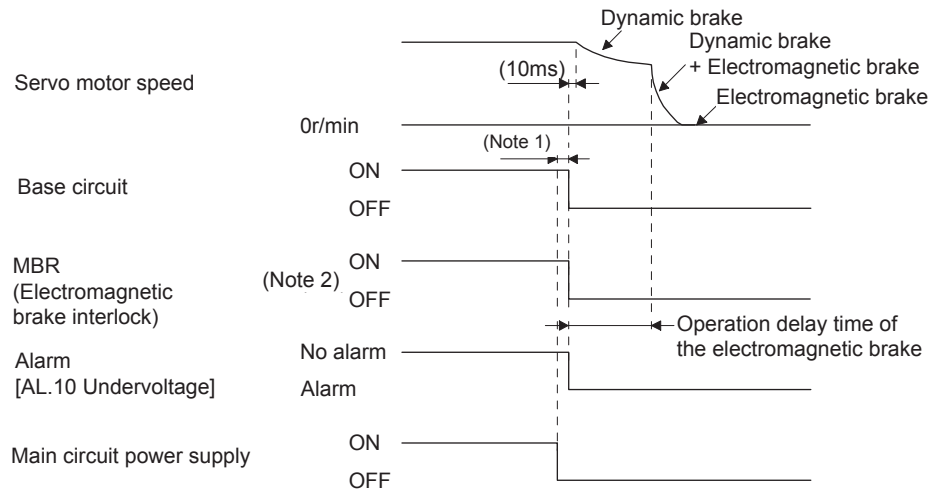

Note 1. Variable according to the operation status.

2. ON : Electromagnetic brake is not activated.

OFF: Electromagnetic brake is activated.

3. SIGNALS AND WIRING

3.11 Grounding

WARNING ● Ground the servo amplifier and servo motor securely.
● To prevent an electric shock, always connect the protective earth (PE) terminal (marked ⊕) of the servo amplifier to the protective earth (PE) of the cabinet.

The servo amplifier switches the power transistor on-off to supply power to the servo motor. Depending on the wiring and ground cable routing, the servo amplifier may be affected by the switching noise (due to di/dt and dv/dt) of the transistor. To prevent such a fault, refer to the following diagram and always ground. To conform to the EMC Directive, refer to the EMC Installation Guidelines (IB(NA)67310).

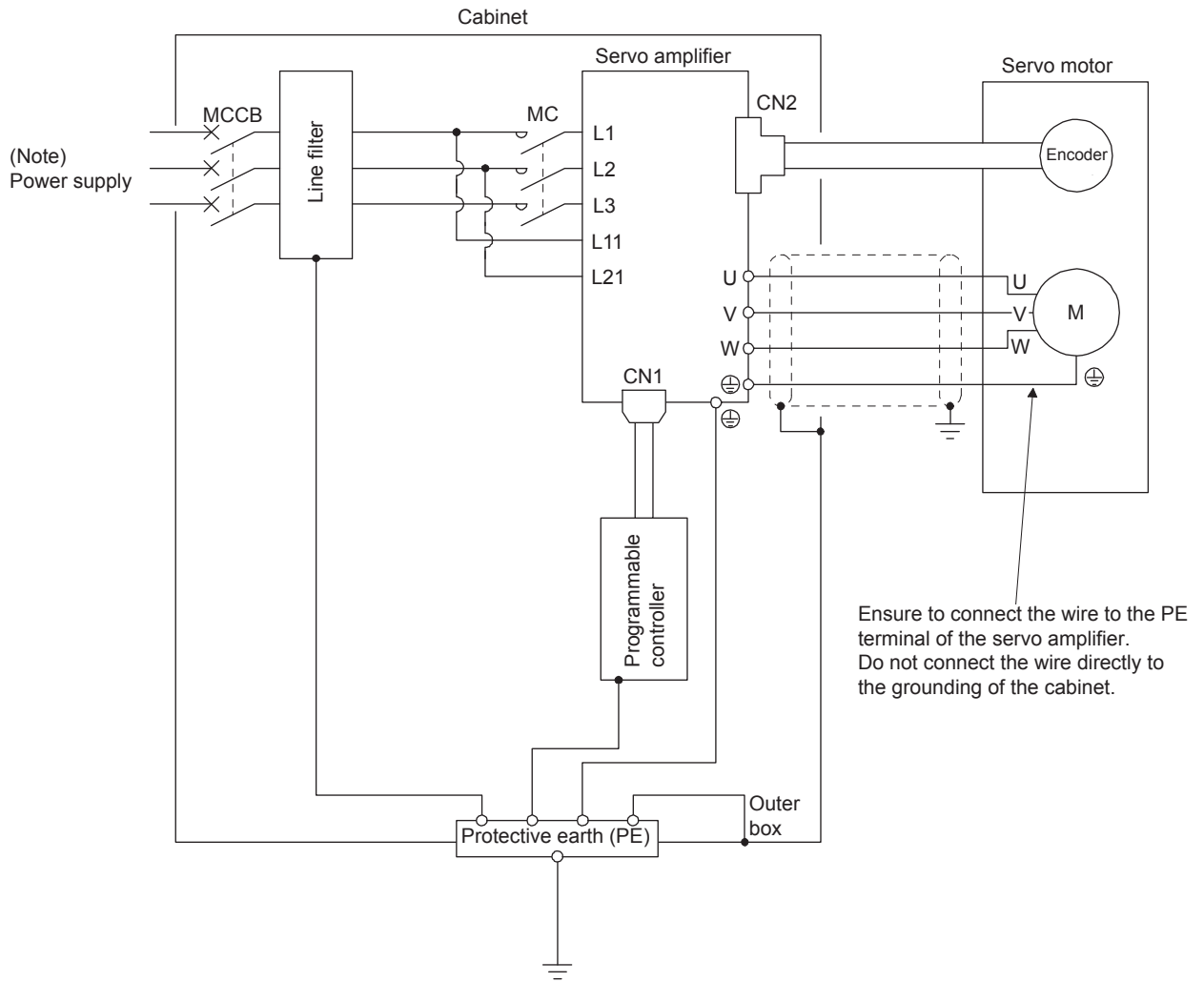

Note. For 1-phase 200 V AC to 240 V AC, connect the power supply to L1 and L3. Leave L2 open. For power supply specifications, refer to section 1.3.

4. STARTUP

4. STARTUP

 **WARNING** ● Do not operate the switches with wet hands. Otherwise, it may cause an electric shock.

 **CAUTION**

- Before starting operation, check the parameters. Improper settings may cause some machines to operate unexpectedly.
- The servo amplifier heat sink, regenerative resistor, servo motor, etc. may be hot while power is on or for some time after power-off. Take safety measures, e.g. provide covers, to prevent accidental contact of hands and parts (cables, etc.) with them.
- During operation, never touch the rotor of the servo motor. Otherwise, it may cause injury.

4.1 Switching power on for the first time

When switching power on for the first time, follow this section to make a startup.

4.1.1 Startup procedure

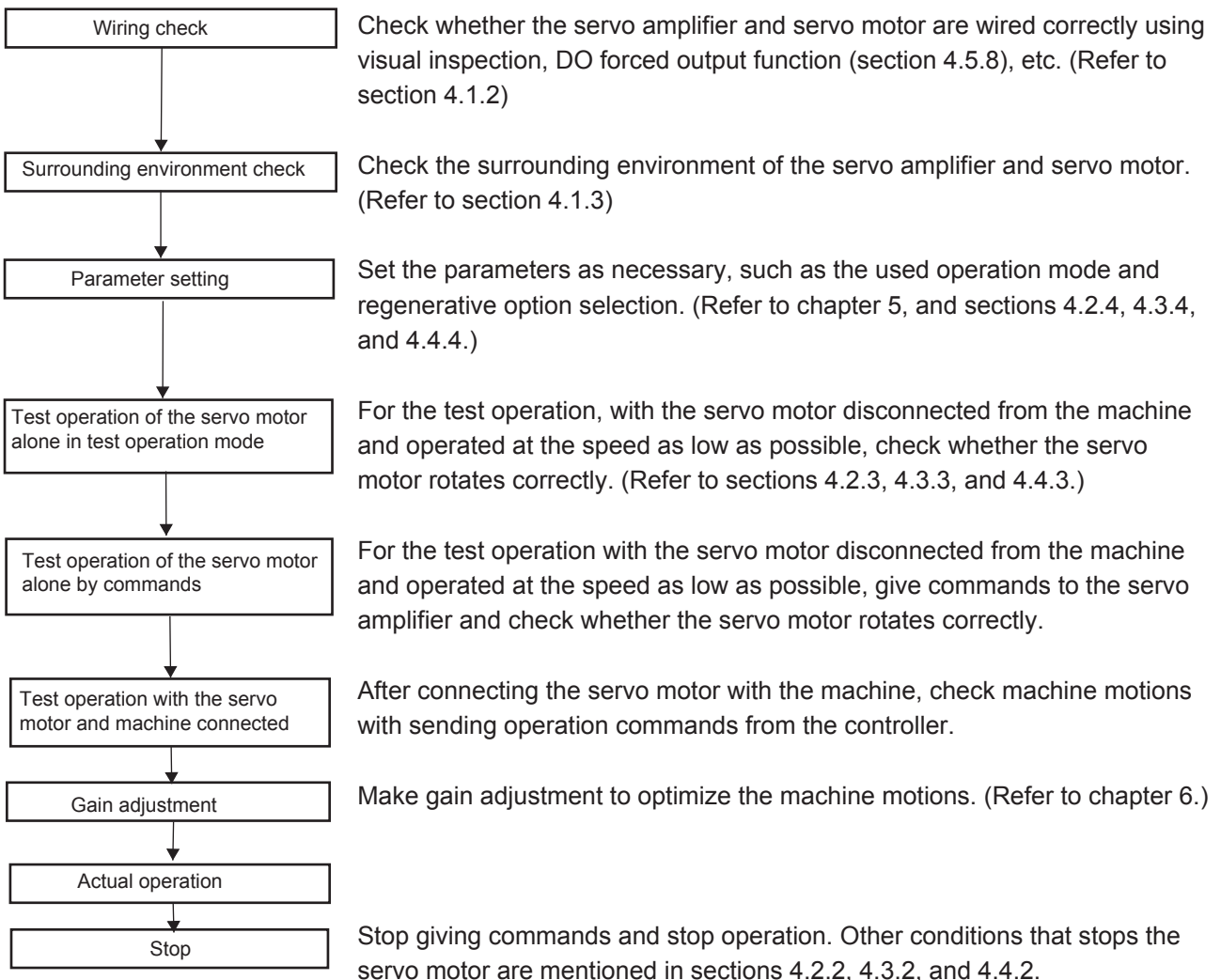

4. STARTUP

4.1.2 Wiring check

(1) Power supply system wiring

Before switching on the main circuit and control circuit power supplies, check the following items.

(a) Power supply system wiring

The power supplied to the power input terminals (L1, L2, L3, L11, and L21) of the servo amplifier should satisfy the defined specifications. (Refer to section 1.3)

(b) Connection of servo amplifier and servo motor

- 1) The servo amplifier power output (U, V, and W) should match in phase with the servo motor power input terminals (U, V, and W).

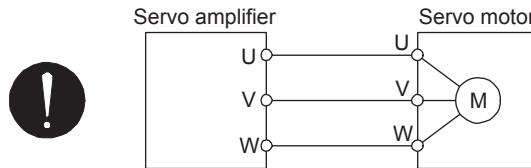

- 2) The power supplied to the servo amplifier should not be connected to the power outputs (U, V, and W). To do so will fail the connected servo amplifier and servo motor.

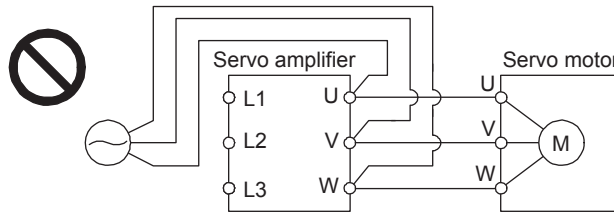

- 3) The grounding terminal of the servo motor is connected to the PE terminal of the servo amplifier.

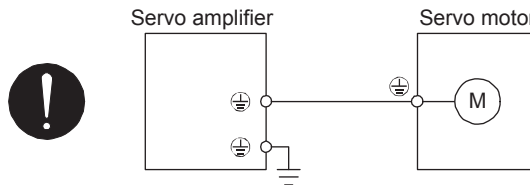

(c) When option and auxiliary equipment are used

- 1) When you use a regenerative option for amplifiers under 5 kW for 200 V class

- The lead wire between P+ and D terminal of CNP2 connector (3.5 kW or less) or TE3 terminal block (5 kW) should not be connected.
- The regenerative option should be connected to P+ terminal and C terminal.
- A twisted cable should be used. (Refer to section 11.2.4)

- 2) When you use a regenerative option for amplifiers under 7 kW for 200 V class

- The lead wire of built-in regenerative resistor connected to P+ terminal and C terminal should not be connected.
- The regenerative option should be connected to P+ terminal and C terminal.
- A twisted cable should be used when wiring is over 5 m and under 10 m. (Refer to section 11.2.4)

4. STARTUP

- 3) When you use a brake unit and a power regenerative converter for 7 kW
 - The lead wire of built-in regenerative resistor connected to P+ terminal and C terminal should not be connected.
 - Brake unit, power regenerative converter or power regenerative common converter should be connected to P+ terminal and N- terminal. (Refer to section 11.3 to 11.5.)
- 4) The power factor improving DC reactor should be connected between P3 and P4. (Refer to section 11.11.)

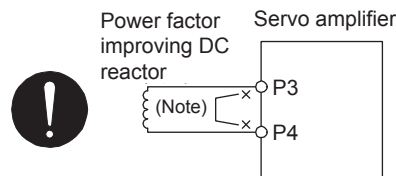

Note. Always disconnect between P3 and P4 terminals.

- (2) I/O signal wiring
 - (a) The I/O signals should be connected correctly.

Use DO forced output to forcibly turn on/off the pins of the CN1 connector. This function can be used to perform a wiring check. In this case, switch on the control circuit power supply only. Refer to section 3.2 for details of I/O signal connection.
 - (b) 24 V DC or higher voltage is not applied to the pins of the CN1 connector.
 - (c) SD and DOCOM of the CN1 connector is not shorted.

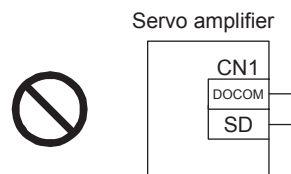

4.1.3 Surrounding environment

- (1) Cable routing
 - (a) The wiring cables should not be stressed.
 - (b) The encoder cable should not be used in excess of its bending life. (Refer to section 10.4.)
 - (c) The connector of the servo motor should not be stressed.
- (2) Environment

Signal cables and power cables are not shorted by wire offcuts, metallic dust or the like.

4. STARTUP

4.2 Startup in position control mode

Make a startup in accordance with section 4.1. This section provides the methods specific to the position control mode.

4.2.1 Power on and off procedures

(1) Power-on

Switch power on in the following procedure. Always follow this procedure at power-on.

- 1) Switch off SON (Servo-on).
- 2) Make sure that a command pulse train is not input.
- 3) Switch on the main circuit power supply and control circuit power supply.
When main circuit power/control circuit power is switched on, the display shows "C (Cumulative feedback pulses)", and in 2 s later, shows data.



In the absolute position detection system, first power-on results in [AL. 25 Absolute position erased] and the servo system cannot be switched on. The alarm can be deactivated by then switching power off once and on again.

Also, if power is switched on at the servo motor speed of 3000 r/min or higher, position mismatch may occur due to external force or the like. Power must therefore be switched on when the servo motor is at a stop.

(2) Power-off

- 1) Make sure that a command pulse train is not input.
- 2) Switch off SON (Servo-on).
- 3) Switch off the main circuit power supply and control circuit power supply.

4.2.2 Stop

If any of the following situations occurs, the servo amplifier suspends the running of the servo motor and brings it to a stop. Refer to section 3.10 for the servo motor with an electromagnetic brake.

| Operation/command | Stopping condition |
|--|---|
| Switch of SON (Servo-on). | The base circuit is shut off and the servo motor coasts. |
| Alarm occurrence | The servo motor decelerates to a stop with the command. With some alarms, however, the dynamic brake operates to bring the servo motor to a stop. (Refer to section 8.1.) |
| EM2 (Forced stop 2) off | The servo motor decelerates to a stop with the command. [AL. E6 Servo forced stop warning] occurs. EM2 has the same function as EM1 in the torque control mode. Refer to section 3.5 for EM1. |
| STO (STO1, STO2) off | The base circuit is shut off and the dynamic brake operates to bring the servo motor to a stop. |
| LSP (Forward rotation stroke end) of LSN (Reverse rotation stroke end) off | It will bring the motor to a sudden stop and make it servo-locked. It can be run in the opposite direction. |

4. STARTUP

4.2.3 Test operation

Before starting actual operation, perform test operation to make sure that the machine operates normally. Refer to section 4.2.1 for the power on and off methods of the servo amplifier.

Test operation of the servo motor alone in JOG operation of test operation mode

In this step, confirm that the servo amplifier and servo motor operate normally.

With the servo motor disconnected from the machine, use the test operation mode and check whether the servo motor correctly rotates at the slowest speed. Refer to section 4.5.9 for the test operation mode.

Test operation of the servo motor alone by commands

In this step, confirm that the servo motor correctly rotates at the slowest speed under the commands from the controller.

Make sure that the servo motor rotates in the following procedure.

- 1) Switch on EM2 (Forced stop 2) and SON (Servo-on). When the servo amplifier is put in a servo-on status, RD (Ready) switches on.
- 2) Switch on LSP (Forward rotation stroke end) and LSN (Reverse rotation stroke end).
- 3) When a pulse train is input from the controller, the servo motor starts rotating. Give a low speed command at first and check the rotation direction, etc. of the servo motor. If the machine does not operate in the intended direction, check the input signal.

Test operation with the servo motor and machine connected

In this step, connect the servo motor with the machine and confirm that the machine operates normally under the commands from the controller.

Make sure that the servo motor rotates in the following procedure.

- 1) Switch on EM2 (Forced stop 2) and SON (Servo-on). When the servo amplifier is put in a servo-on status, RD (Ready) switches on.
- 2) Switch on LSP (Forward rotation stroke end) and LSN (Reverse rotation stroke end).
- 3) When a pulse train is input from the controller, the servo motor starts rotating. Give a low speed command at first and check the operation direction, etc. of the machine. If the machine does not operate in the intended direction, check the input signal. In the status display, check for any problems of the servo motor speed, command pulse frequency, load ratio, etc.
- 4) Then, check automatic operation with the program of the controller.

4. STARTUP

4.2.4 Parameter setting

| POINT |
|---|
| ●The following encoder cables are of four-wire type. When using any of these encoder cables, set [Pr. PC22] to "1 _ _ _" to select the four-wire type. Incorrect setting will result in [AL. 16 Encoder initial communication error 1]. MR-EKCBL30M-L MR-EKCBL30M-H MR-EKCBL40M-H MR-EKCBL50M-H |

In the position control mode, the servo amplifier can be used by merely changing the basic setting parameters ([Pr. PA _ _]) mainly.

As necessary, set other parameters.

4.2.5 Actual operation

Start actual operation after confirmation of normal operation by test operation and completion of the corresponding parameter settings. Perform a home position return as necessary.

4. STARTUP

4.2.6 Trouble at start-up

| | |
|---|--|
|  | CAUTION ● Never adjust or change the parameter values extremely as it will make operation unstable. |
|---|--|

| | |
|--------------|---|
| POINT | ● Using the optional MR Configurator2, you can refer to reason for rotation failure, etc. |
|--------------|---|

The following faults may occur at start-up. If any of such faults occurs, take the corresponding action.

(1) Troubleshooting

| No. | Start-up sequence | Fault | Investigation | Possible cause | Reference |
|-----|---------------------------------------|--|---|---|---------------------|
| 1 | Power on | <ul style="list-style-type: none"> ▪ LED is not lit. ▪ LED flickers. | Not improved even if CN1, CN2 and CN3 connectors are disconnected. | 1. Power supply voltage fault 2. The servo amplifier is malfunctioning. | / |
| | | | Improved when CN1 connector is disconnected. | Power supply of CN1 cabling is shorted. | |
| | | | Improved when CN2 connector is disconnected. | 1. Power supply of encoder cabling is shorted. 2. Encoder is malfunctioning. | |
| | | | Improved when CN3 connector is disconnected. | Power supply of CN3 cabling is shorted. | |
| | | Alarm occurs. | Refer to chapter 8 and remove cause. | | Chapter 8 (Note) |
| 2 | Switch on SON (Servo-on). | Alarm occurs. | Refer to chapter 8 and remove cause. | | Chapter 8 (Note) |
| | | Servo motor shaft is not servo-locked. (Servo motor shaft is free.) | 1. Check the display to see if the servo amplifier is ready to operate. 2. Check the external I/O signal indication (section 4.5.7) to see if SON (Servo-on) is on. | 1. SON (Servo-on) is not input. (wiring mistake) 2. 24 V DC power is not supplied to DICOM. | Section 4.5.7 |
| 3 | Input command pulse. (Test operation) | Servo motor does not rotate. | Check the cumulative command pulse on the status display (section 4.5.3). | 1. Wiring mistake (a) For open collector pulse train input, 24 V DC power is not supplied to OPC. (b) LSP and LSN are not on. 2. Pulse is not input from the controller. | Section 4.5.3 |
| | | Servo motor run in reverse direction. | | Mistake in setting of [Pr. PA13]. 1. Mistake in wiring to controller. 2. Mistake in setting of [Pr. PA14]. | Chapter 5 |
| 4 | Gain adjustment | Rotation ripples (speed fluctuations) are large at low speed. | Make gain adjustment in the following procedure. 1. Increase the auto tuning response level. 2. Repeat acceleration and deceleration several times to complete auto tuning. | Gain adjustment fault | Chapter 6 |
| | | Large load inertia moment causes the servo motor shaft to oscillate side to side. | If the servo motor may be run with safety, repeat acceleration and deceleration several times to complete auto tuning. | Gain adjustment fault | Chapter 6 |
| 5 | Cyclic operation | Position shift occurs | Confirm the cumulative command pulses, cumulative feedback pulses and actual servo motor position. | Pulse counting error, etc. due to noise. | (2) in this section |

Note. Only a list of alarms and warnings is listed in chapter 8. Refer to "MELSERVO-J4 Servo Amplifier Instruction Manual (Troubleshooting)" for details of alarms and warnings.

4. STARTUP

(2) How to find the cause of position shift

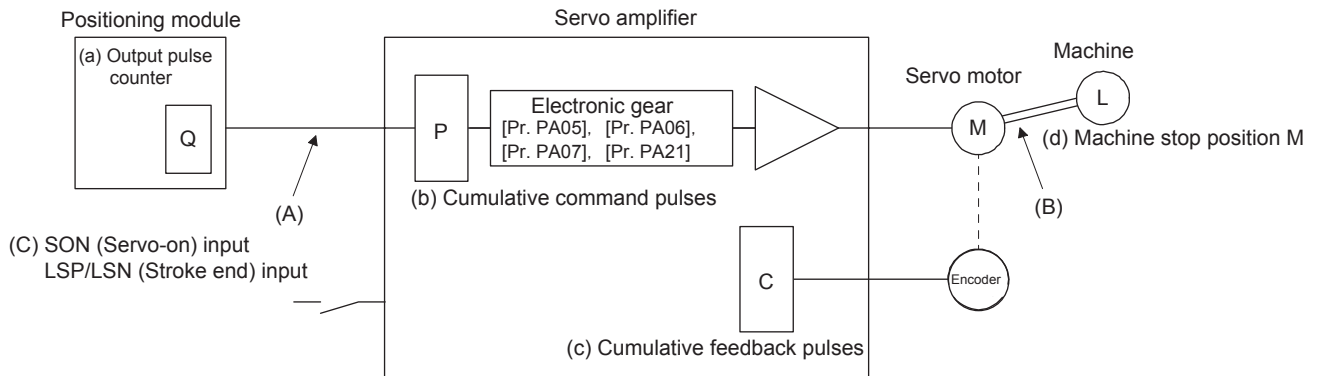

When a position shift occurs, check (a) output pulse counter display, (b) cumulative command pulse, (c) cumulative feedback pulse, and (d) machine stop position in the above diagram.

(A), (B) and (C) indicate position shift causes. For example, (A) indicates that noise entered the wiring between positioning unit and servo amplifier, causing pulses to be miss-counted.

In a normal status without position shift, there are the following relationships.

1) $Q = P$ (Output counter of the positioning module = Cumulative command pulses of the servo amplifier)

2) When [Pr. PA21] is "0 _ _ _"

$$P \cdot \frac{CMX[Pr.PA06]}{CDV[Pr.PA07]} = C \text{ (Cumulative command pulses} \times \text{Electronic gear} = \text{Cumulative feedback pulses)}$$

3) When [Pr. PA21] is "1 _ _ _"

$$P \cdot \frac{4194304}{FBP[Pr.PA05]} = C$$

4) When [Pr. PA21] is "2 _ _ _"

$$P \cdot \frac{CMX[Pr.PA06]}{CDV[Pr.PA07]} \times 16 = C$$

5) $C \cdot \Delta l = M$ (Cumulative feedback pulses \times Travel distance per pulse = Machine position)

Check for a position mismatch in the following sequence.

1) When $Q \neq P$

Noise entered the pulse train signal wiring between positioning unit and servo amplifier, causing pulses to be miss-counted. (Cause A)

Make the following check or take the following measures.

- Check how the shielding is done.
- Change the open collector type to the differential line driver type.
- Run wiring away from the power circuit.
- Install a data line filter. (Refer to section 11.14 (2) (a).)
- Change the [Pr. PA13 Command pulse input form] setting.

4. STARTUP

- 2) When $P \cdot \frac{CMX}{CDV} \neq C$

During operation, SON (Servo-on), LSP (Forward rotation stroke end), or LSN (Reverse rotation stroke end) was switched off; or CR (Clear) or RES (Reset) was switched on. (Cause C)

- 3) When $C \cdot \Delta l \neq M$

Mechanical slip occurred between the servo motor and machine. (Cause B)

4.3 Startup in speed control mode

Make a startup in accordance with section 4.1. This section provides the methods specific to the speed control mode.

4.3.1 Power on and off procedures

(1) Power-on

Switch power on in the following procedure. Always follow this procedure at power-on.

- 1) Switch off SON (Servo-on).
- 2) Make sure that ST1 (Forward rotation start) and ST2 (Reverse rotation start) are off.
- 3) Switch on the main circuit power supply and control circuit power supply.
When main circuit power/control circuit power is switched on, the display shows "r (Servo motor speed)", and in 2 s later, shows data.



(2) Power-off

- 1) Switch off ST1 (Forward rotation start) and ST2 (Reverse rotation start).
- 2) Switch off SON (Servo-on).
- 3) Switch off the main circuit power supply and control circuit power supply.

4.3.2 Stop

If any of the following situations occurs, the servo amplifier suspends the running of the servo motor and brings it to a stop.

Refer to section 3.10 for the servo motor with an electromagnetic brake.

| Operation/command | Stopping condition |
|---|---|
| Switch of SON (Servo-on). | The base circuit is shut off and the servo motor coasts. |
| Alarm occurrence | The servo motor decelerates to a stop with the command. With some alarms, however, the dynamic brake operates to bring the servo motor to a stop. (Refer to section 8.1.) |
| EM2 (Forced stop 2) off | The servo motor decelerates to a stop with the command. [AL. E6 Servo forced stop warning] occurs. EM2 has the same function as EM1 in the torque control mode. Refer to section 3.5 for EM1. |
| STO (STO1, STO2) off | The base circuit is shut off and the dynamic brake operates to bring the servo motor to a stop. |
| LSP (Forward rotation stroke end) of LSN (Reverse rotation stroke end) off | It will bring the motor to a sudden stop and make it servo-locked. It can be run in the opposite direction. |
| Simultaneous on or off of ST1 (Forward rotation start) and ST2 (Reverse rotation start) | The servo motor is decelerated to a stop. |

4. STARTUP

4.3.3 Test operation

Before starting actual operation, perform test operation to make sure that the machine operates normally. Refer to section 4.3.1 for the power on and off methods of the servo amplifier.

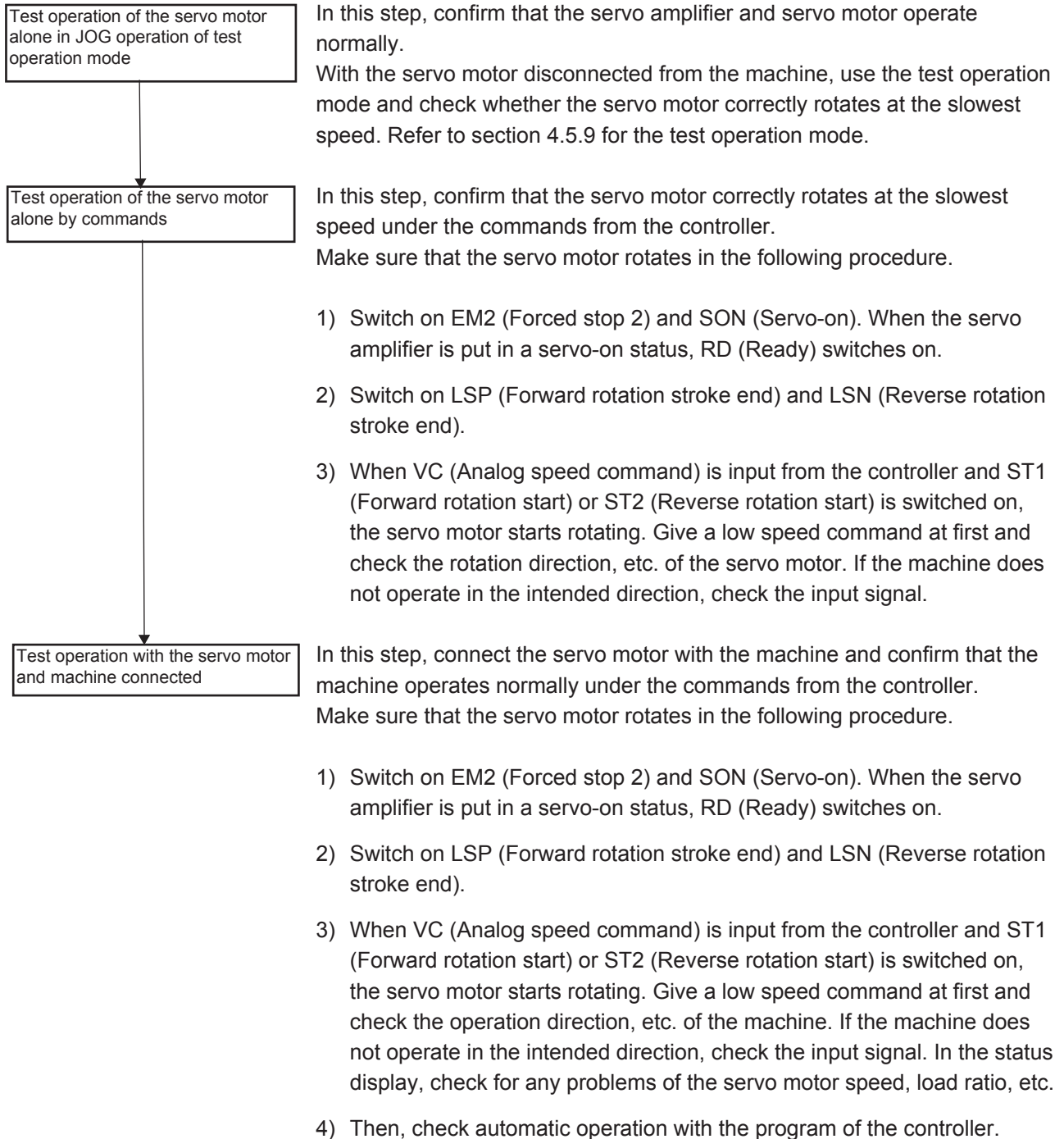

4. STARTUP

4.3.4 Parameter setting

| POINT |
|--|
| ● The following encoder cables are of four-wire type. When using any of these encoder cables, set [Pr. PC22] to "1 _ _ _" to select the four-wire type. Incorrect setting will result in [AL. 16 Encoder initial communication error 1]. MR-EKCBL30M-L MR-EKCBL30M-H MR-EKCBL40M-H MR-EKCBL50M-H |

When using this servo in the speed control mode, change [Pr. PA01] setting to select the speed control mode. In the speed control mode, the servo can be used by merely changing the basic setting parameters ([Pr. PA _ _]) and extension setting parameters ([Pr. PC _ _]) mainly.

As necessary, set other parameters.

4. STARTUP

4.3.5 Actual operation

Start actual operation after confirmation of normal operation by test operation and completion of the corresponding parameter settings.

4.3.6 Trouble at start-up

| | | |
|---|---------|---|
|  | CAUTION | ● Never adjust or change the parameter values extremely as it will make operation unstable. |
|---|---------|---|

| | |
|-------|---|
| POINT | ● Using the optional MR Configurator2, you can refer to reason for rotation failure, etc. |
|-------|---|

The following faults may occur at start-up. If any of such faults occurs, take the corresponding action.

| No. | Start-up sequence | Fault | Investigation | Possible cause | Reference |
|-----|---|--|--|--|------------------|
| 1 | Power on | <ul style="list-style-type: none"> • LED is not lit. • LED flickers. | Not improved even if CN1, CN2, and CN3 connectors are disconnected. | <ol style="list-style-type: none"> 1. Power supply voltage fault 2. The servo amplifier is malfunctioning. | / |
| | | | Improved when CN1 connector is disconnected. | Power supply of CN1 cabling is shorted. | |
| | | | Improved when CN2 connector is disconnected. | <ol style="list-style-type: none"> 1. Power supply of encoder cabling is shorted. 2. Encoder is malfunctioning. | |
| | | | Improved when CN3 connector is disconnected. | Power supply of CN3 cabling is shorted. | |
| | | Alarm occurs. | Refer to chapter 8 and remove cause. | | Chapter 8 (Note) |
| 2 | Switch on SON (Servo-on). | Alarm occurs. | Refer to chapter 8 and remove cause. | | Chapter 8 (Note) |
| | | Servo motor shaft is not servo-locked. (Servo motor shaft is free.) | <ol style="list-style-type: none"> 1. Check the display to see if the servo amplifier is ready to operate. 2. Check the external I/O signal indication (section 4.5.7) to see if SON (Servo-on) is on. | <ol style="list-style-type: none"> 1. SON (Servo-on) is not input. (wiring mistake) 2. 24 V DC power is not supplied to DICOM. | Section 4.5.7 |
| 3 | Switch on ST1 (Forward rotation start) or ST2 (Reverse rotation start). | Servo motor does not rotate. | Call the status display (section 4.5.3) and check the input voltage of VC (Analog speed command). | Analog speed command is 0 V. | Section 4.5.3 |
| | | | Call the external I/O signal display (section 4.5.7) and check the on/off status of the input signal. | LSP, LSN, ST1, and ST2 are off. | Section 4.5.7 |
| | | | Check the internal speed commands 1 to 7 ([Pr. PC05] to [Pr. PC11]). | Set value is 0. | Section 5.2.3 |
| | | | Check the forward rotation torque limit ([Pr. PA11]) and the reverse rotation torque limit ([Pr. PA12]). | Torque limit level is too low as compared to the load torque. | Section 5.2.1 |
| | | | When TLA (Analog torque limit) is usable, check the input voltage on the status display. | Torque limit level is too low as compared to the load torque. | Section 4.5.3 |

4. STARTUP

| No. | Start-up sequence | Fault | Investigation | Possible cause | Reference |
|-----|-------------------|---|---|-----------------------|-----------|
| 4 | Gain adjustment | Rotation ripples (speed fluctuations) are large at low speed. | Make gain adjustment in the following procedure. 1. Increase the auto tuning response level. 2. Repeat acceleration and deceleration several times to complete auto tuning. | Gain adjustment fault | Chapter 6 |
| | | Large load inertia moment causes the servo motor shaft to oscillate side to side. | If the servo motor may be run with safety, repeat acceleration and deceleration several times to complete auto tuning. | Gain adjustment fault | Chapter 6 |

Note. Only a list of alarms and warnings is listed in chapter 8. Refer to "MELSERVO-J4 Servo Amplifier Instruction Manual (Troubleshooting)" for details of alarms and warnings.

4. STARTUP

4.4 Startup in torque control mode

Make a startup in accordance with section 4.1. This section provides the methods specific to the torque control mode.

4.4.1 Power on and off procedures

(1) Power-on

Switch power on in the following procedure. Always follow this procedure at power-on.

- 1) Switch off SON (Servo-on).
- 2) Make sure that RS1 (Forward rotation selection) and RS2 (Reverse rotation selection) are off.
- 3) Switch on the main circuit power supply and control circuit power supply.
Data is displayed in 2 s after "U" (Analog torque command) is displayed.



(2) Power-off

- 1) Switch off RS1 (Forward rotation selection) or RS2 (Reverse rotation selection).
- 2) Switch off SON (Servo-on).
- 3) Switch off the main circuit power supply and control circuit power supply.

4.4.2 Stop

If any of the following situations occurs, the servo amplifier suspends the running of the servo motor and brings it to a stop. Refer to section 3.10 for the servo motor with an electromagnetic brake.

| Operation/command | Stopping condition |
|---|---|
| Switch off SON (Servo-on). | The base circuit is shut off and the servo motor coasts. |
| Alarm occurrence | The servo motor decelerates to a stop with the command. With some alarms, however, the dynamic brake operates to bring the servo motor to a stop. (Refer to section 8.1.) |
| EM2 (Forced stop 2) off | The servo motor decelerates to a stop with the command. [AL. E6 Servo forced stop warning] occurs. EM2 has the same function as EM1 in the torque control mode. Refer to section 3.5 for EM1. |
| STO (STO1, STO2) off | The base circuit is shut off and the dynamic brake operates to bring the servo motor to a stop. |
| Simultaneous on or off of RS1 (Forward rotation selection) and RS2 (Reverse rotation selection) | The servo motor coasts. |

4. STARTUP

4.4.3 Test operation

Before starting actual operation, perform test operation to make sure that the machine operates normally. Refer to section 4.4.1 for the power on and off methods of the servo amplifier.

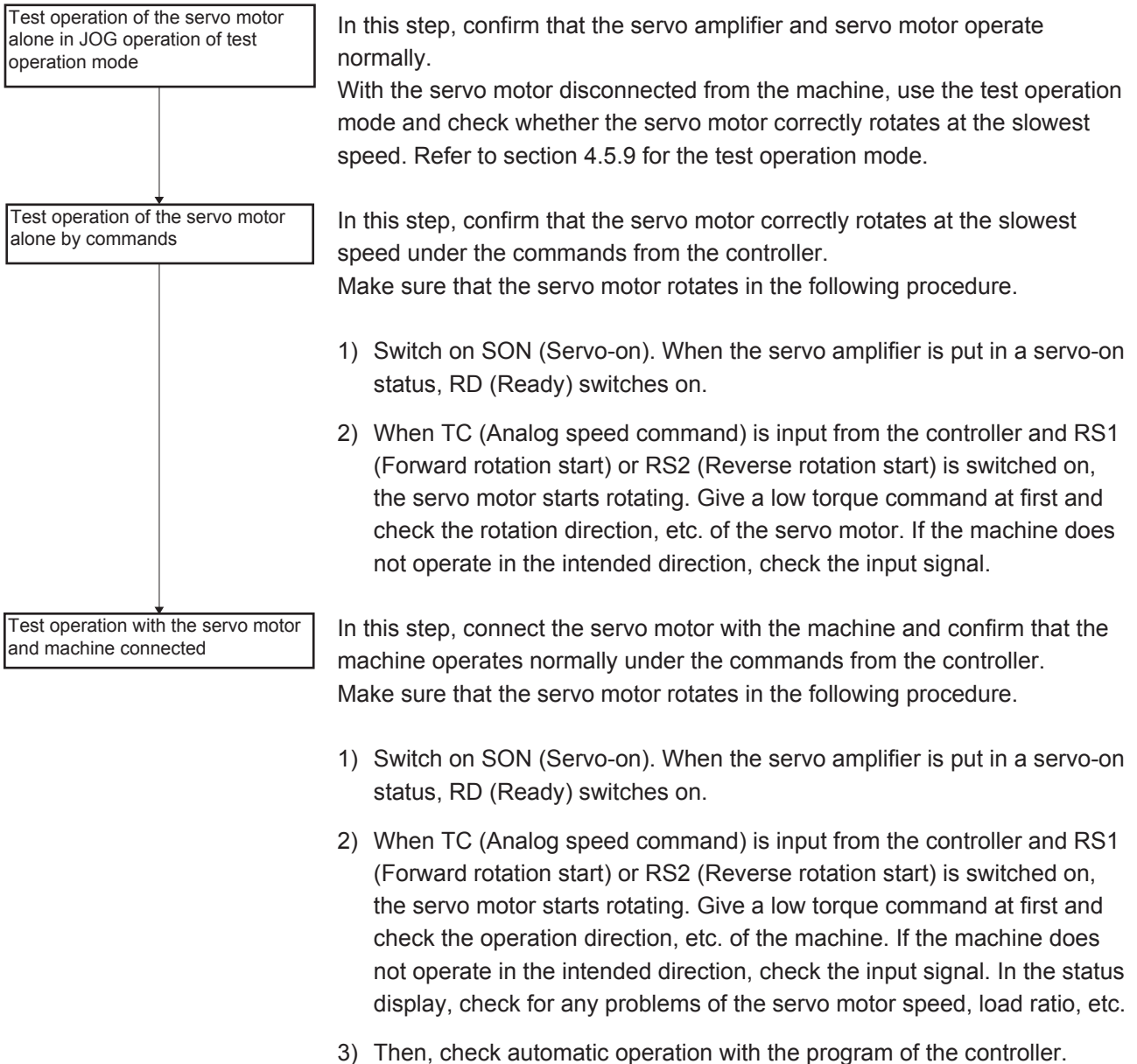

4. STARTUP

4.4.4 Parameter setting

| POINT |
|---|
| ●The following encoder cables are of four-wire type. When using any of these encoder cables, set [Pr. PC22] to "1 _ _ _" to select the four-wire type. Incorrect setting will result in [AL. 16 Encoder initial communication error 1]. MR-EKCBL30M-L MR-EKCBL30M-H MR-EKCBL40M-H MR-EKCBL50M-H |

When using this servo in the torque control mode, change [Pr. PA01] setting to select the torque control mode. In the torque control mode, the servo can be used by merely changing the basic setting parameters ([Pr. PA _ _]) and extension setting parameters ([Pr. PC _ _]) mainly. As necessary, set other parameters.

4.4.5 Actual operation

Start actual operation after confirmation of normal operation by test operation and completion of the corresponding parameter settings.

4. STARTUP

4.4.6 Trouble at start-up

| | |
|---|---|
|  | CAUTION ● Never adjust or change the parameter values extremely as it will make unstable movement. |
|---|---|

| | |
|--------------|---|
| POINT | ● Using the optional MR Configurator2, you can refer to reason for rotation failure, etc. |
|--------------|---|

The following faults may occur at start-up. If any of such faults occurs, take the corresponding action.

| No. | Start-up sequence | Fault | Investigation | Possible cause | Reference |
|-----|---|--|--|--|------------------|
| 1 | Power on | <ul style="list-style-type: none"> • LED is not lit. • LED flickers. | Not improved even if CN1, CN2, and CN3 connectors are disconnected. | 1. Power supply voltage fault 2. The servo amplifier is malfunctioning. | / |
| | | | Improved when CN1 connector is disconnected. | Power supply of CN1 cabling is shorted. | |
| | | | Improved when CN2 connector is disconnected. | 1. Power supply of encoder cabling is shorted. 2. Encoder is malfunctioning. | |
| | | | Improved when CN3 connector is disconnected. | Power supply of CN3 cabling is shorted. | |
| | | Alarm occurs. | Refer to chapter 8 and remove cause. | | Chapter 8 (Note) |
| 2 | Switch on SON (Servo-on). | Alarm occurs. | Refer to chapter 8 and remove cause. | | Chapter 8 (Note) |
| | | (Servo motor shaft is free.) | Call the external I/O signal display (section 4.5.7) and check the on/off status of the input signal. | 1. SON (Servo-on) is not input. (wiring mistake) 2. 24 V DC power is not supplied to DICOM. | Section 4.5.7 |
| 3 | Switch on RS1 (Forward rotation start) or RS2 (Reverse rotation start). | Servo motor does not rotate. | Call the status display (section 4.5.3) and check the input voltage of TC (Analog torque command). | Analog torque command is 0 V. | Section 4.5.3 |
| | | | Call the external I/O signal display (section 4.5.7) and check the on/off status of the input signal. | RS1 and RS2 are off. | Section 4.5.7 |
| | | | Check the internal speed commands 1 to 7 ([Pr. PC05] to [Pr. PC11]). | Set value is 0. | Section 5.2.3 |
| | | | Check the analog torque command maximum output ([Pr. PC13]) value. | Torque command level is too low as compared to the load torque. | Section 5.2.3 |
| | | | Check the forward rotation torque limit ([Pr. PA11]) and the reverse rotation torque limit ([Pr. PA12]). | Set value is 0. | Section 5.2.1 |

Note. Only a list of alarms and warnings is listed in chapter 8. Refer to "MELSERVO-J4 Servo Amplifier Instruction Manual (Troubleshooting)" for details of alarms and warnings.

4. STARTUP

4.5 Display and operation sections

4.5.1 Summary

The MR-J4-A servo amplifier has the display section (5-digit, 7-segment LED) and operation section (4 pushbuttons) for servo amplifier status display, alarm display, parameter setting, etc.

The operation section and display data are described below.

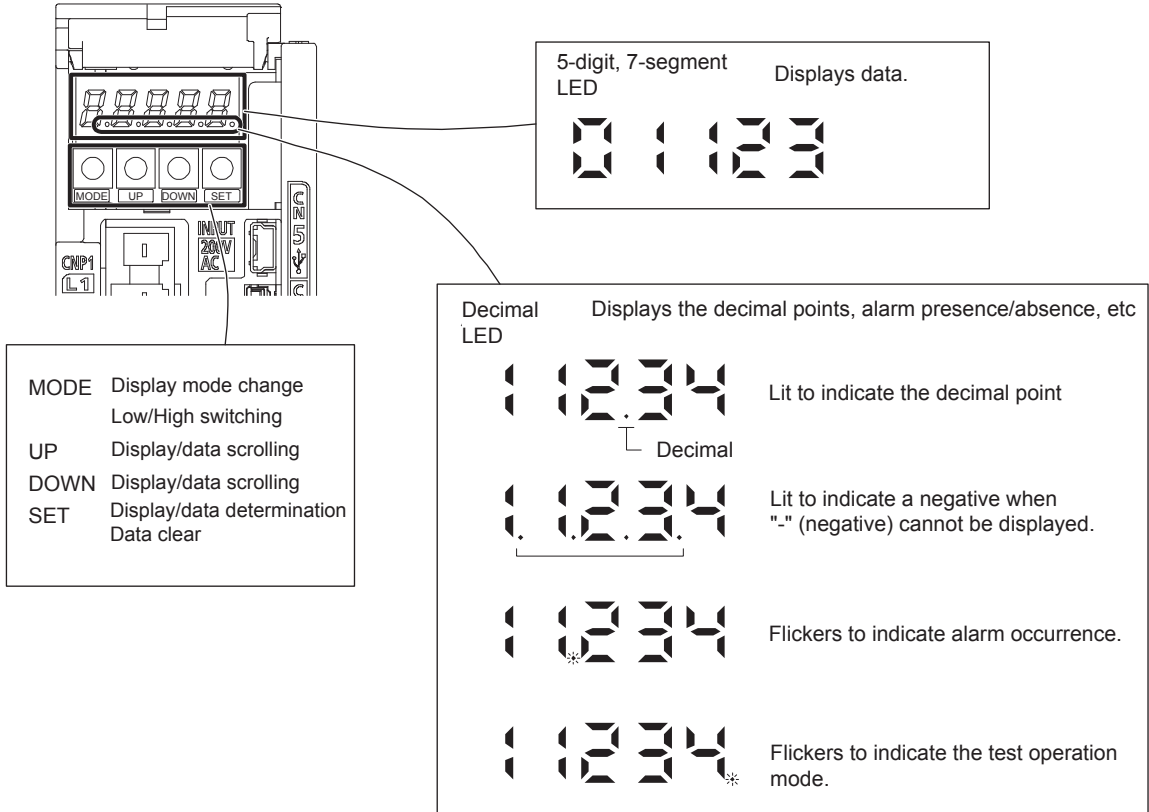

4. STARTUP

4.5.2 Display flowchart

Press the "MODE" button once to shift to the next display mode. Refer to section 4.5.3 and later for the description of the corresponding display mode.

To refer to and set the gain/filter parameters, extension setting parameters and I/O setting parameters, make them valid with [Pr. PA19 Parameter writing inhibit].

| Display mode transition | Initial screen | Function | Reference |
|--|----------------|--|---------------|
| <pre> graph TD A([Status display]) --> B([One-touch tuning]) B --> C([Diagnosis]) C --> D([Alarms]) D --> E([Basic setting parameters]) E --> F([Gain/filter parameters]) F --> G([Extension setting parameters]) G --> H([I/O setting parameters]) H --> I([Extension setting 2 parameters]) I --> J([Extension setting 3 parameters]) J --> A </pre> | | Servo status display. [] appears at power-on. (Note) | Section 4.5.3 |
| | | One-touch tuning Select this when performing the one-touch tuning. | Section 6.2 |
| | | Sequence display, external signal display, output signal (DO) forced output, test operation, software version display, VC automatic offset, servo motor series ID display, servo motor type ID display, servo motor encoder ID display, drive recorder enabled/disabled display. | Section 4.5.4 |
| | | Current alarm display, alarm history display, parameter error number display. | Section 4.5.5 |
| | | Display and setting of basic setting parameters. | Section 4.5.6 |
| | | Display and setting of gain/filter parameters. | |
| | | Display and setting of extension setting parameters. | |
| | | Display and setting of I/O setting parameters. | |
| | | Display and setting of extension setting 2 parameters. | |
| | | Display and setting of extension setting 3 parameters. | |

Note. When the axis name is set to the servo amplifier using MR Configurator2, the axis name is displayed and the servo status is then displayed.

4. STARTUP

4.5.3 Status display mode

The servo status during operation is shown on the 5-digit, 7-segment LED display. Press the "UP" or "DOWN" button to change display data as desired. When the required data is selected, the corresponding symbol is displayed. Press the "SET" button to display that data. At only power-on, however, data appears after the symbol of the status display selected in [Pr. PC36] has been shown for 2 s.

(1) Display transition

After selecting the status display mode with the "MODE" button, pressing the "UP" or "DOWN" button changes the display as shown below.

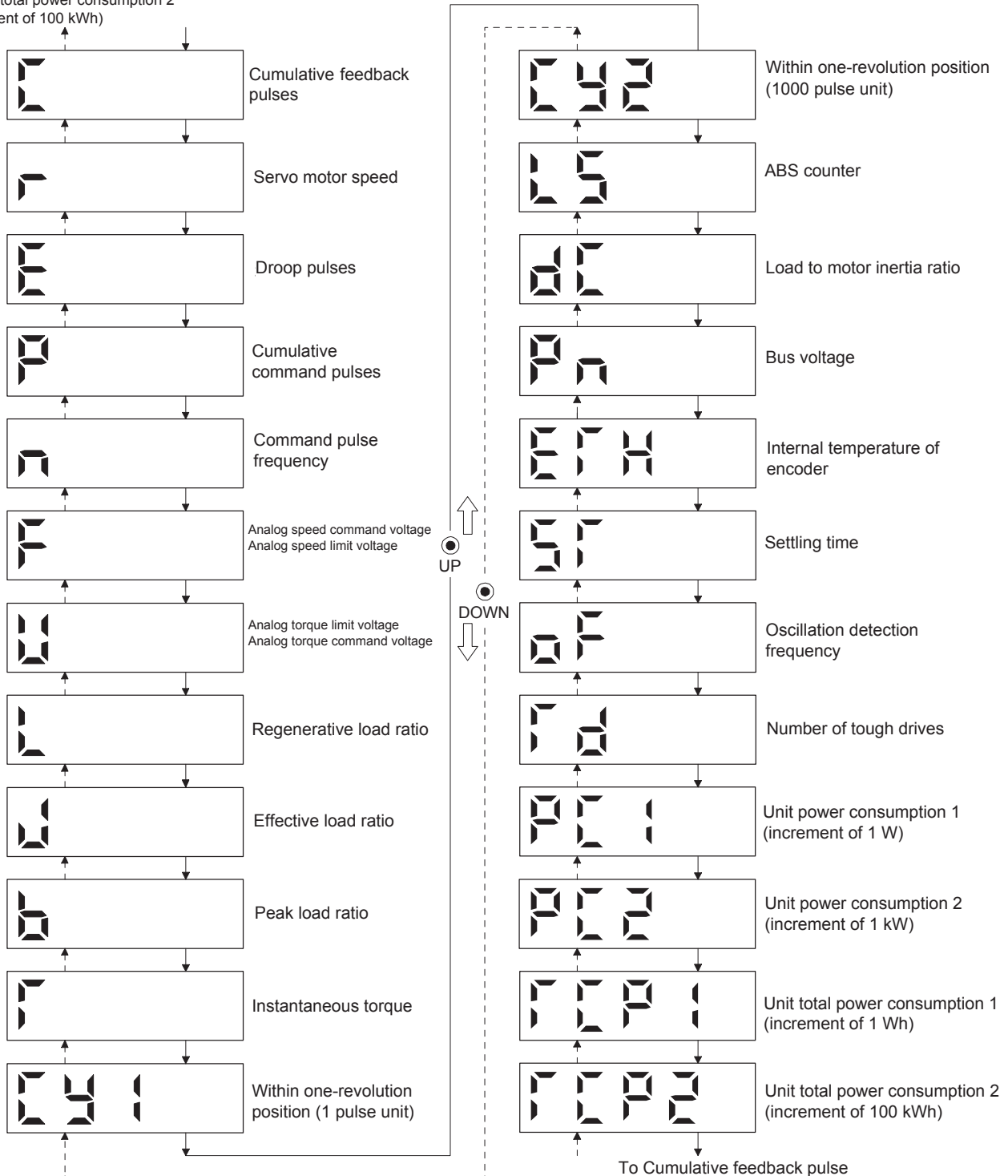

To Unit total power consumption 2
(increment of 100 kWh)



4. STARTUP

(2) Display examples

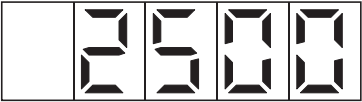
The following table shows the display examples.

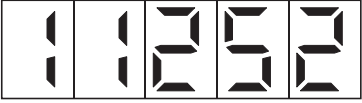
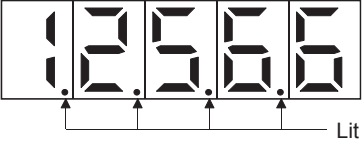
| Item | State | Displayed data |
|-----------------------------|--------------------------------|---|
| | | Servo amplifier display |
| Servo motor speed | Forward rotation at 2500 r/min |  |
| | Reverse rotation at 3000 r/min |  Reverse rotation is indicated by "-". |
| Load to motor inertia ratio | 7.00 times |  |
| ABS counter | 11252 rev |  |
| | -12566 rev |  Lit Negative value is indicated by the lit decimal points in the upper four digits. |

4. STARTUP

(3) Status display list

The following table lists the servo statuses that may be shown. Refer to appendix 10 for the measurement point.

| Status display | Symbol | Unit | Description |
|--|--------|-------------|---|
| Cumulative feedback pulses | C | pulse | Feedback pulses from the servo motor encoder are counted and displayed. The values in excess of ± 99999 can be counted. However, the counter shows only the lower five digits of the actual value since the servo amplifier display is five digits. Press the "SET" button to reset the display value to zero. The value of minus is indicated by the lit decimal points in the upper four digits. |
| Servo motor speed | r | r/min | The servo motor speed is displayed. It is displayed rounding off 0.1 r/min unit. |
| Droop pulses | E | pulse | The number of droop pulse in the deviation counter is displayed. The decimal points in the upper four digits are lit for reverse rotation pulses. The values in excess of ± 99999 can be counted. However, the counter shows only the lower five digits of the actual value since the servo amplifier display is five digits. The number of pulses displayed is in the encoder pulse unit. |
| Cumulative command pulses | P | pulse | Position command input pulses are counted and displayed. As the value displayed is not yet multiplied by the electronic gear (CMX/CDV), it may not match the indication of the cumulative feedback pulses. The values in excess of ± 99999 can be counted. However, the counter shows only the lower five digits of the actual value since the servo amplifier display is five digits. Press the "SET" button to reset the display value to zero. When the servo motor is rotating in the reverse direction, the decimal points in the upper four digits are lit. |
| Command pulse frequency | n | kpps | The frequency of position command input pulses is counted and displayed. The value displayed is not multiplied by the electronic gear (CMX/CDV). |
| Analog speed command voltage | F | V | 1) Torque control mode Input voltage of VLA (Analog speed limit) voltage is displayed. |
| Analog speed limit voltage | | | 2) Speed control mode Input voltage of VC (Analog speed command) voltage is displayed |
| Analog torque command voltage | U | V | 1) Position control mode and speed control mode Voltage of TLA (Analog torque limit) voltage is displayed. |
| Analog torque limit voltage | | | 2) Torque control mode Voltage of TC (Analog torque command) voltage is displayed. |
| Regenerative load ratio | L | % | The ratio of regenerative power to permissible regenerative power is displayed in %. |
| Effective load ratio | J | % | The continuous effective load current is displayed. The effective value in the past 15 s is displayed relative to the rated current of 100 %. |
| Peak load ratio | b | % | The maximum occurrence torque is displayed. The highest value in the past 15 s is displayed relative to the rated current of 100 %. |
| Instantaneous torque | T | % | The instantaneous occurrence torque is displayed. The value of torque being occurred is displayed in real time considering a rated torque as 100%. |
| Within one-revolution position (1 pulse unit) | Cy1 | pulse | Position within one revolution is displayed in encoder pulses. The values in excess of ± 99999 can be counted. However, the counter shows only the lower five digits of the actual value since the servo amplifier display is five digits. When the servo motor rotates in the CCW direction, the value is added. |
| Within one-revolution position (1000 pulse unit) | Cy2 | 1000 pulses | The within one-revolution position is displayed in 1000 pulse increments of the encoder. When the servo motor rotates in the CCW direction, the value is added. |
| ABS counter | LS | rev | The travel distance from the home position is displayed as multi-revolution counter value of the absolute position encoder in the absolute position detection system. |

4. STARTUP

| Status display | Symbol | Unit | Description |
|---|--------|------------|---|
| Load to motor inertia ratio | dC | Multiplier | The estimated ratio of the load inertia moment to the servo motor shaft inertia moment is displayed. |
| Bus voltage | Pn | V | The voltage of main circuit converter (between P+ and N-) is displayed. |
| Encoder inside temperature | ETh | °C | Inside temperature of encoder detected by the encoder is displayed. |
| Settling time | ST | ms | Settling time is displayed. When it exceeds 1000 mm/s, "1000" will be displayed. |
| Oscillation detection frequency | oF | Hz | Frequency at the time of oscillation detection is displayed. |
| Number of tough operations | Td | times | The number of tough drive functions activated is displayed. |
| Unit power consumption 1 (increment of 1 W) | PC1 | W | Unit power consumption is displayed by increment of 1 W. Positive value indicate power running, and negative value indicate regeneration. The values in excess of ±99999 can be counted. However, the counter shows only the lower five digits of the actual value since the servo amplifier display is five digits. |
| Unit power consumption 2 (increment of 1 kW) | PC2 | kW | Unit power consumption is displayed by increment of 1 kW. Positive value indicate power running, and negative value indicate regeneration. |
| Unit total power consumption 1 (increment of 1 Wh) | TPC1 | Wh | Unit total power consumption is displayed by increment of 1 Wh. Positive value is cumulated during power running and negative value during regeneration. The values in excess of ±99999 can be counted. However, the counter shows only the lower five digits of the actual value since the servo amplifier display is five digits. |
| Unit total power consumption 2 (increment of 100 kWh) | TPC2 | 100 Wh | Unit total power consumption is displayed by increment of 100 kWh. Positive value is cumulated during power running and negative value during regeneration. |

(4) Changing the status display screen

The status display item of the servo amplifier display shown at power-on can be changed by changing [Pr. PC36] settings. The item displayed in the initial status changes with the control mode as follows.









| Control mode | Status display |
|-----------------|--|
| Position | Cumulative feedback pulses |
| Position/speed | Cumulative feedback pulses/servo motor speed |
| Speed | Servo motor speed |
| Speed/torque | Servo motor speed/analog torque command voltage |
| Torque | Analog torque command voltage |
| Torque/position | Analog torque command voltage/cumulative feedback pulses |

4. STARTUP

4.5.4 Diagnostic mode

| Name | | Display | Description |
|---|----------------------------|-------------------------|--|
| Sequence | | | Not ready Indicates that the servo amplifier is being initialized or an alarm has occurred. |
| | | | Ready Indicates that the servo was switched on after completion of initialization and the servo amplifier is ready to operate. |
| Drive recorder enabled/disabled display | | | Drive recorder enabled When an alarm occurs in the status, the drive recorder will operate and write the status of occurrence. |
| | | | Drive recorder enabled The drive recorder will not operate on the following conditions. 1. You are using the graph function of MR Configurator2. 2. You are using the machine analyzer function. 3. [Pr. PF21] is set to "-1". |
| External I/O signal display | | Refer to section 4.5.7. | This Indicates the on/off status of external I/O signal. The upper segments correspond to the input signals and the lower segments to the output signals. |
| Output signal (DO) forced output | | | This allows digital output signal to be switched on/off forcibly. For details, refer to section 4.5.8. |
| Test operation mode | JOG operation | | JOG operation can be performed when there is no command from an external controller. For details, refer to section 4.5.9 (2). |
| | Positioning operation | | Positioning operation can be performed when there is no command from an external controller. MR Configurator2 is required to perform positioning operation. For details, refer to section 4.5.9 (3). |
| | Motor-less operation | | Without connecting the servo motor, output signals or status display monitoring can be provided in response to the input device as if the servo motor is actually running. For details, refer to section 4.5.9 (4). |
| | Machine analyzer operation | | Merely connecting the servo amplifier allows the resonance point of the mechanical system to be measured. MR Configurator2 is required to perform machine analyzer operation. Refer to section 11.7 for details. |
| | For manufacturer | | This is for manufacturer. |









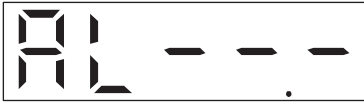

4. STARTUP

| Name | Display | Description |
|--------------------------|---|---|
| Software version - Lower |  | Indicates the version of the software. |
| Software version - Upper |  | Indicates the system number of the software. |
| Automatic VC offset |  | <p>If offset voltages in the analog circuits inside and outside the servo amplifier cause the servo motor to rotate slowly at VC (Analog speed command) or VLA (Analog speed limit) of 0 V, this function automatically makes zero-adjustment of offset voltages.</p> <p>When using this function, enable the function in the following procedure. When it is enabled, [Pr. PC37] value changes to the automatically adjusted offset voltage.</p> <ol style="list-style-type: none"> 1) Push "SET" once. 2) Set the number in the first digit to 1 with "UP"/"DOWN". 3) Push "SET". <p>This function cannot be used if the input voltage of VC or VLA is - +0.4 V or less, or + 0.4 V or more.</p> |
| Servo motor series ID |  | <p>Push the "SET" button to show the series ID of the servo motor currently connected.</p> <p>For indication details, refer to the Servo Motor Instruction Manual (Vol. 3).</p> |
| Servo motor type ID |  | <p>Push the "SET" button to show the type ID of the servo motor currently connected.</p> <p>For indication details, refer to the Servo Motor Instruction Manual (Vol. 3).</p> |
| Servo motor encoder ID |  | <p>Push the "SET" button to show the encoder ID of the servo motor currently connected.</p> <p>For indication details, refer to the Servo Motor Instruction Manual (Vol. 3).</p> |
| For manufacturer |  | This is for manufacturer. |
| For manufacturer |  | This is for manufacturer. |

4. STARTUP

4.5.5 Alarm mode

The current alarm, past alarm history and parameter error are displayed. The lower 2 digits on the display indicate the alarm number that has occurred or the parameter number in error.

| Name | Display | Description |
|---|---|---|
| Current alarm |  | Indicates no occurrence of an alarm. |
| |  | Indicates the occurrence of [AL. 33.1 Main circuit voltage error]. Flickers at alarm occurrence. |
| Alarm history |  | Indicates that the last alarm is [AL. 50.1 Thermal overload error 1 during operation]. |
| |  | Indicates the second last alarm is [AL. 33.1 Main circuit voltage error]. |
| |  | Indicates the third last alarm is [AL. 10.1 Voltage drop in the control power]. |
| | ⋮ | ⋮ |
| |  | Indicates that there is no tenth alarm in the past. |
| |  | Indicates that there is no eleventh alarm in the past. |
| |  | Indicates that there is no twelfth alarm in the past. |
| | ⋮ | ⋮ |
|  | Indicates that there is no sixteenth alarm in the past. | |
| Parameter error No. |  | This indicates no occurrence of [AL. 37 Parameter error]. |
| |  | The data content error of [Pr. PA12 Reverse rotation torque limit]. |

4. STARTUP

Functions at occurrence of an alarm

- (1) Any mode screen displays the current alarm.
- (2) Even during alarm occurrence, the other screen can be viewed by pressing the button in the operation area. At this time, the decimal point in the fourth digit remains flickering.
- (3) For any alarm, remove its cause and clear it in any of the following methods. (Refer to chapter 8 for the alarms that can be cleared.)
 - (a) Switch power off, then on.
 - (b) Push the "SET" button on the current alarm screen.
 - (c) Turn on RES (Reset).
- (4) Use [Pr. PC18] to clear the alarm history.
- (5) Push "UP" or "DOWN" to move to the next history.

4. STARTUP

4.5.6 Parameter mode

POINT

● To use the I/O setting parameters, change [Pr. PA19 Parameter writing inhibit].
(Refer to section 5.1.1)

(1) Parameter mode transition

After selecting the corresponding parameter mode with the "MODE" button, pushing the "UP" or "DOWN" button changes the display as shown below.

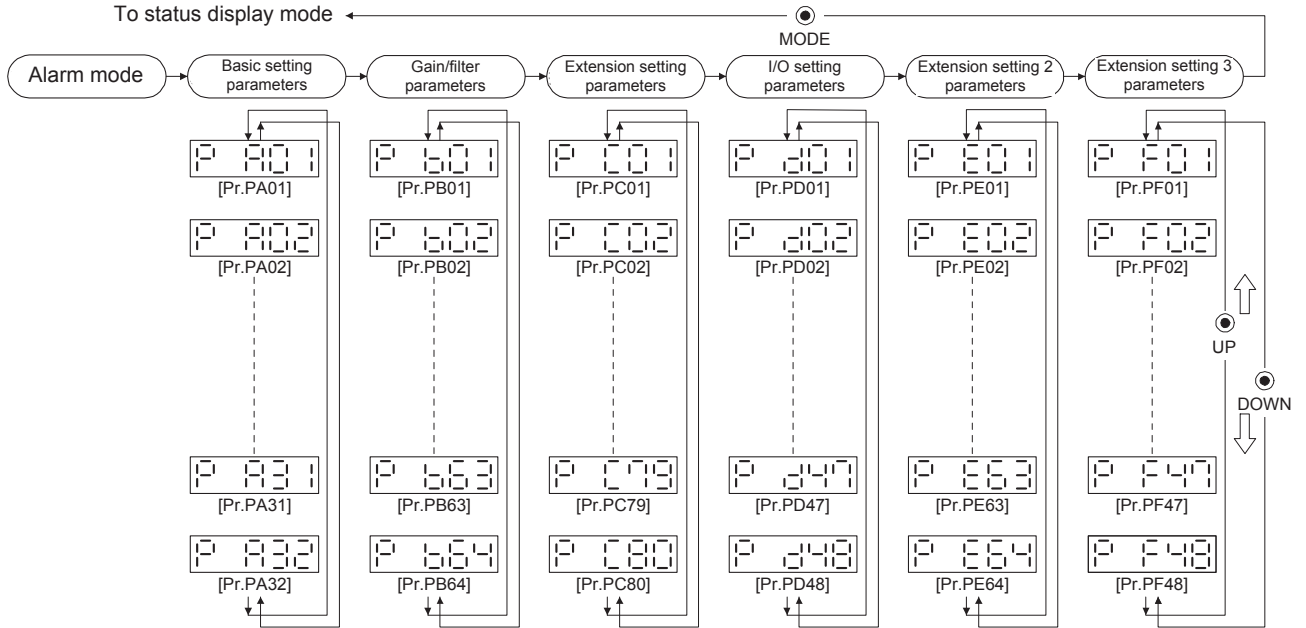

4. STARTUP

(2) Operation example

(a) Parameters of 5 or less digits

The following example shows the operation procedure performed after power-on to change the control mode to the speed control mode with [Pr. PA01 Operation mode]. Press "MODE" to switch to the basic setting parameter screen.

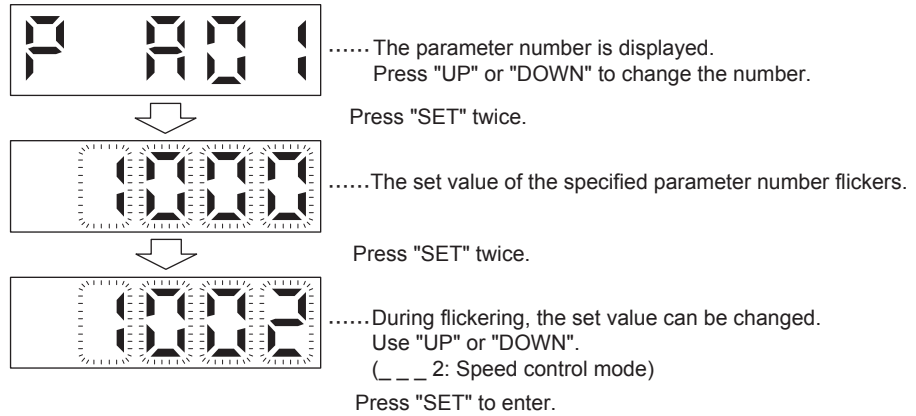

To shift to the next parameter, press the "UP" or "DOWN" button.

When changing the [Pr. PA01] setting, change its set value, then switch power off once and switch it on again to make the new value valid.

4. STARTUP

(b) Parameters of 6 or more digits

The following example gives the operation procedure to change the electronic gear numerator to "123456" with [Pr. PA06 Electronic gear numerator].

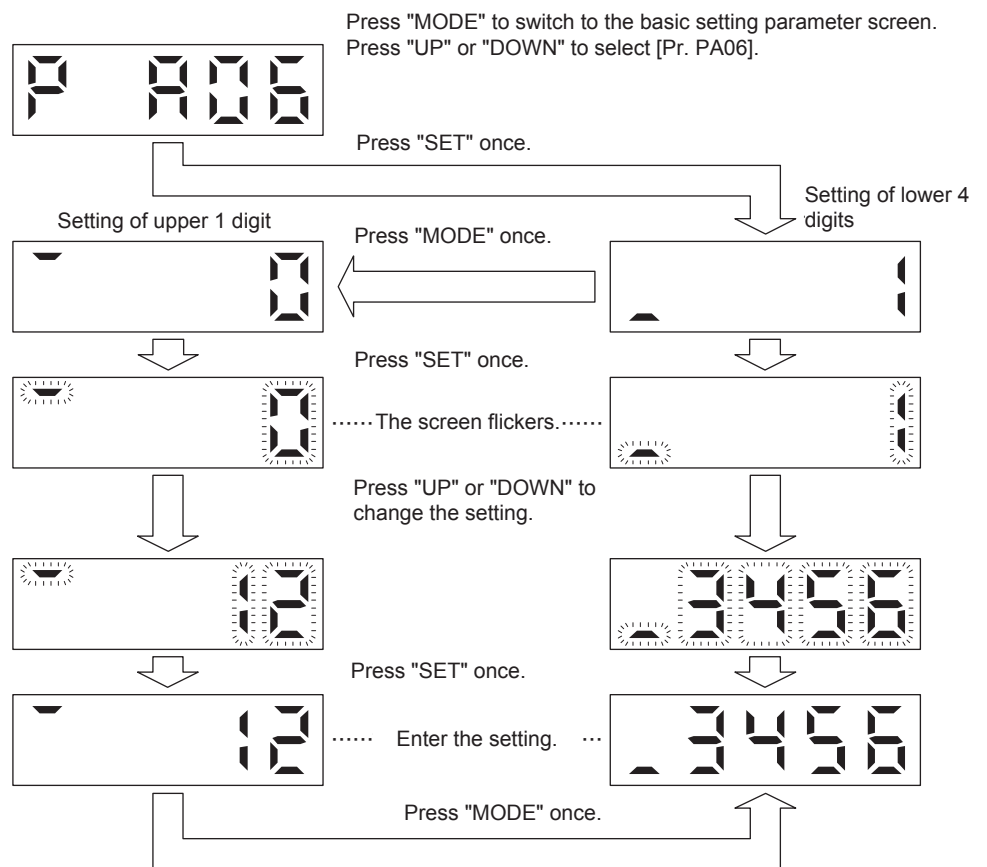

4. STARTUP

4.5.7 External I/O signal display

| |
|--|
| POINT |
| <p>● The I/O signal settings can be changed using the I/O setting parameters [Pr. PD03] to [Pr. PD28].</p> |

The on/off states of the digital I/O signals connected to the servo amplifier can be confirmed.

(1) Operation

Call the display screen shown after power-on. Using the "MODE" button, show the diagnostic screen.

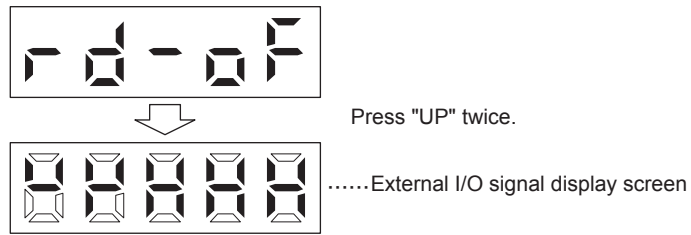

(2) Display definition

The 7-segment LED segments and CN1 connector pins correspond as shown below.

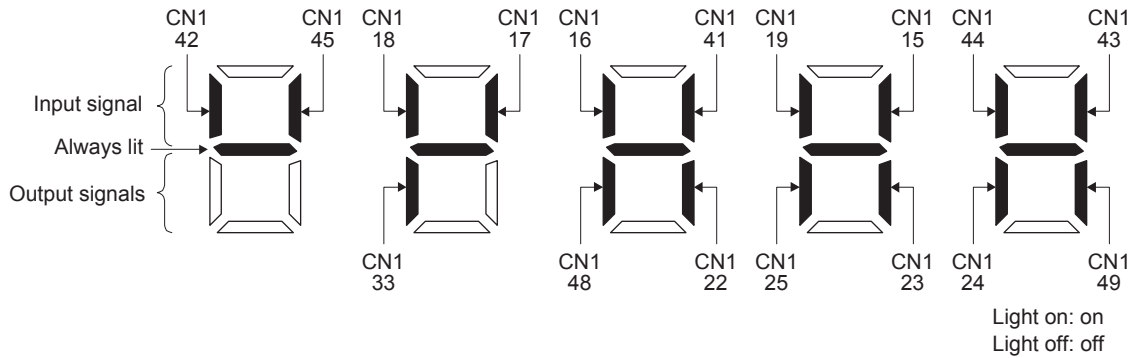

The LED segment corresponding to the pin is lit to indicate on, and is extinguished to indicate off. The signals corresponding to the pins in the respective control modes are indicated below.

4. STARTUP

(a) Control modes and I/O signals

| Connector | Pin No. | Signal input/output (Note 1) I/O | (Note 2) Symbols of I/O signals in control modes | | | | | | Related parameter |
|-----------|---------|----------------------------------|--|--------|-----|---------|-----|----------|-------------------|
| | | | P | P/S | S | S/T | T | T/P | |
| CN1 | 15 | I | SON | SON | SON | SON | SON | SON | Pr. PD03/Pr. PD04 |
| | 16 | I | / | -/SP2 | SP2 | SP2/SP2 | SP2 | SP2/- | Pr. PD05/Pr. PD06 |
| | 17 | I | PC | PC/ST1 | ST1 | ST1/RS2 | RS2 | RS2/PC | Pr. PD07/Pr. PD08 |
| | 18 | I | TL | TL/ST2 | ST2 | ST2/RS1 | RS1 | RS1/TL | Pr. PD09/Pr. PD10 |
| | 19 | I | RES | RES | RES | RES | RES | RES | Pr. PD11/Pr. PD12 |
| | 22 | O | INP | INP/SA | SA | SA/- | / | -/INP | Pr. PD23 |
| | 23 | O | ZSP | ZSP | ZSP | ZSP | ZSP | ZSP | Pr. PD24 |
| | 24 | O | INP | INP/SA | SA | SA/- | / | -/INP | Pr. PD25 |
| | 25 | O | TLC | TLC | TLC | TLC/VLC | VLC | VLC/TLC | Pr. PD26 |
| | 33 | O | OP | OP | OP | OP | OP | OP | / |
| | 41 | I | CR | CR/SP1 | SP1 | SP1/SP1 | SP1 | SP1/CR | Pr. PD13/Pr. PD14 |
| | 42 | I | EM2 | EM2 | EM2 | EM2 | EM2 | EM2 | / |
| | 43 | I | LSP | LSP | LSP | LSP/- | / | -/LSP | Pr. PD17/Pr. PD18 |
| | 44 | I | LSN | LSN | LSN | LSN/- | / | -/LSN | Pr. PD19/Pr. PD20 |
| | 45 | I | LOP | LOP | LOP | LOP | LOP | LOP | Pr. PD21/Pr. PD22 |
| 48 | O | ALM | ALM | ALM | ALM | ALM | ALM | / | |
| 49 | O | RD | RD | RD | RD | RD | RD | Pr. PD28 | |

Note 1. I: input signal, O: output signal

2. P: position control mode, S: speed control mode, T: torque control mode

P/S: position/speed control switching mode, S/T: speed/torque control switching mode, T/P: torque/position switching mode

(b) Symbol and signal names

| Symbol | Application | Symbol | Application |
|--------|---------------------------------|--------|--|
| SON | Servo-on | RES | Reset |
| LSP | Forward rotation stroke end | EM2 | Forced stop 2 |
| LSN | Reverse rotation stroke end | LOP | Control switching |
| CR | Clear | TLC | Limiting torque |
| SP1 | Speed selection 1 | VLC | Limiting speed |
| SP2 | Speed selection 2 | RD | Ready |
| PC | Proportion control | ZSP | Zero speed detection |
| ST1 | Forward rotation start | INP | In-position |
| ST2 | Reverse rotation start | SA | Speed reached |
| RS1 | Forward rotation selection | ALM | Malfunction |
| RS2 | Reverse rotation selection | OP | Encoder Z-phase pulse (open collector) |
| TL | External torque limit selection | / | / |

4. STARTUP

(3) Display data at initial values

(a) Position control mode

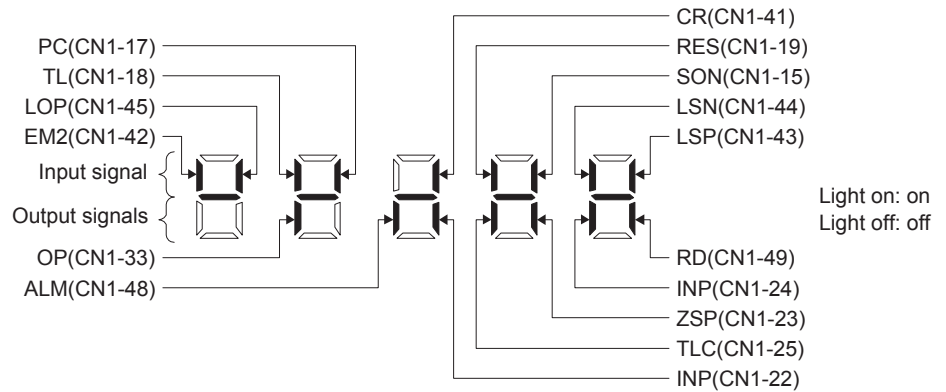

(b) Speed control mode

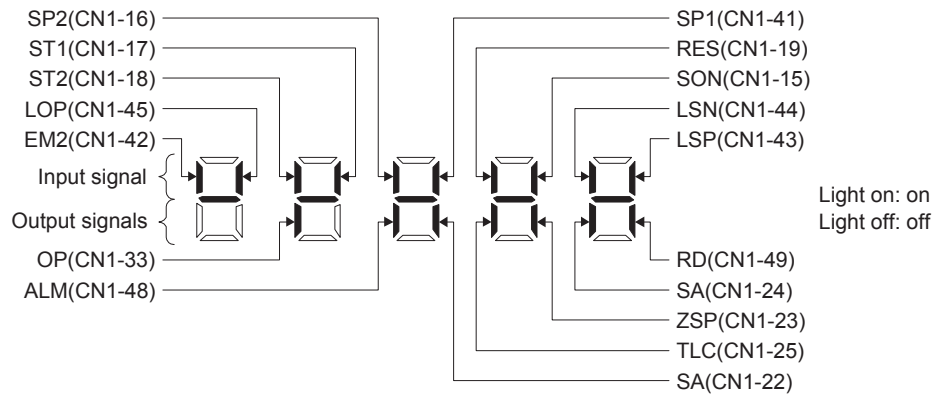

(c) Torque control mode

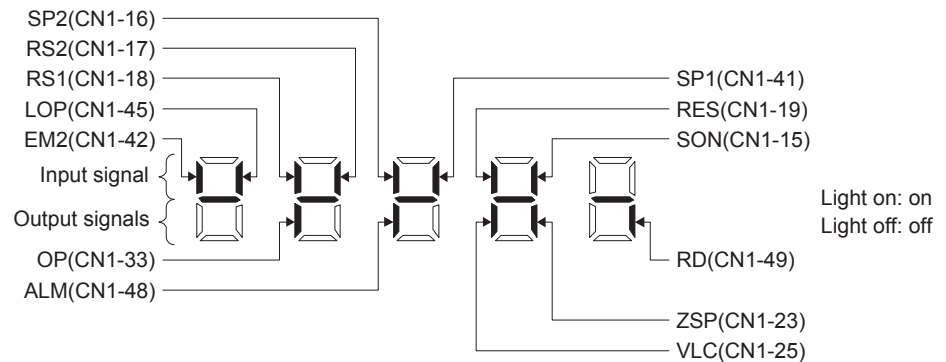

4. STARTUP

4.5.8 Output signal (DO) forced output

| |
|--|
| POINT |
| <p>● When the servo system is used in a vertical lift application, turning on MBR (Electromagnetic brake interlock) by the DO forced output after assigning it to connector CN1 will release the electromagnetic brake, causing a drop. Take drop preventive measures on the machine side.</p> |

Output signals can be switched on/off forcibly independently of the servo status. This function is used for output signal wiring check, etc. This operation must be performed in the servo off state by turning off the SON (Servo-on).

Operation

Call the display screen shown after power-on. Using the "MODE" button, show the diagnostic screen.

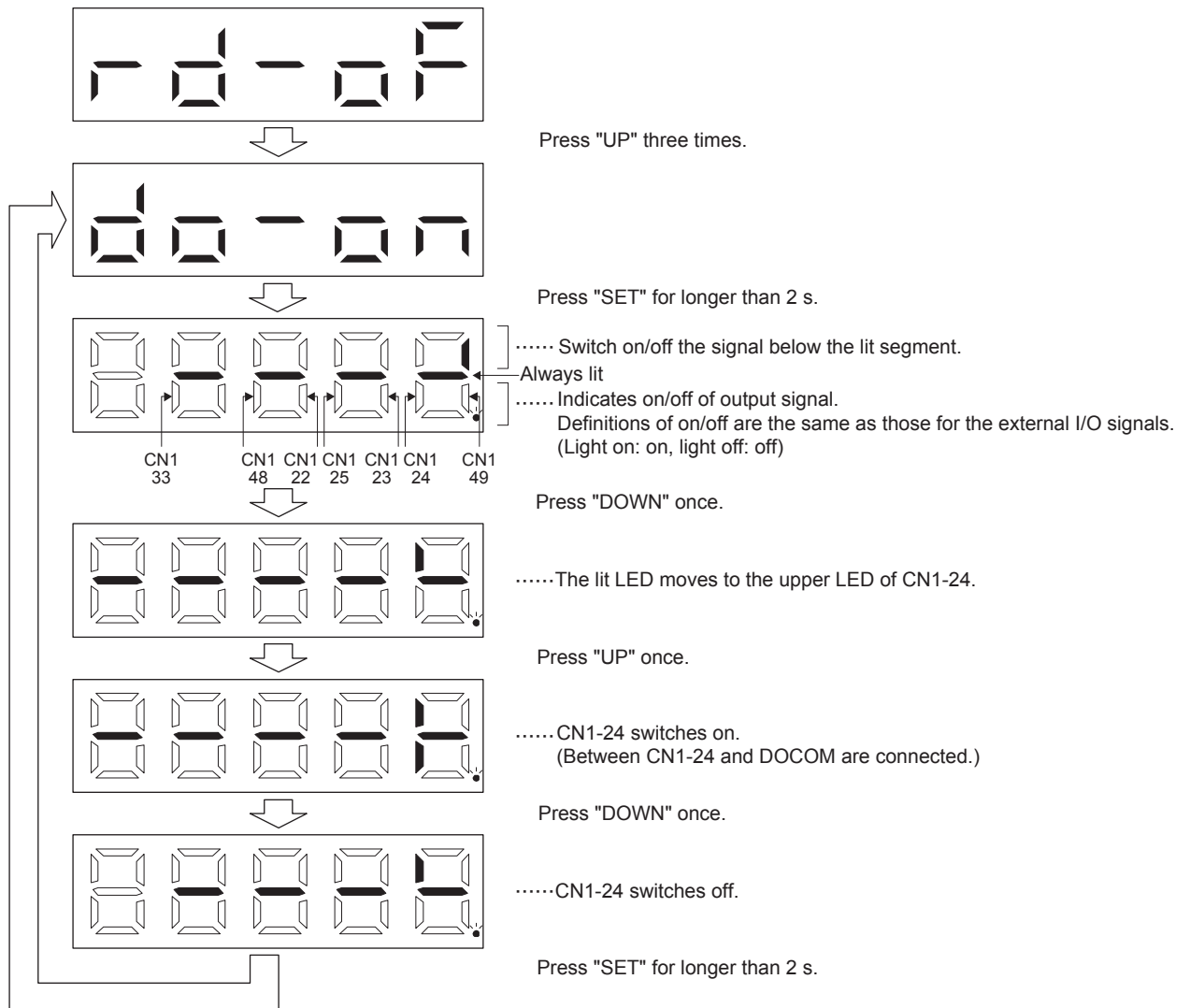

4. STARTUP

4.5.9 Test operation mode

| | |
|--|---|
|  CAUTION | ● The test operation mode is designed for checking servo operation. Do not use it for actual operation. |
| | ● If the servo motor operates unexpectedly, use EM2 (Forced stop 2) to stop it. |

| POINT |
|---|
| ● The test operation mode cannot be used in the absolute position detection system by DIO ([Pr. PA03: ___1]). |
| ● MR Configurator2 is required to perform positioning operation. |
| ● Test operation cannot be performed if SON (Servo-on) is not turned off. |

(1) Mode switching

Call the display screen shown after power-on. Select JOG operation or motor-less operation in the following procedure. Using the "MODE" button, show the diagnostic screen.

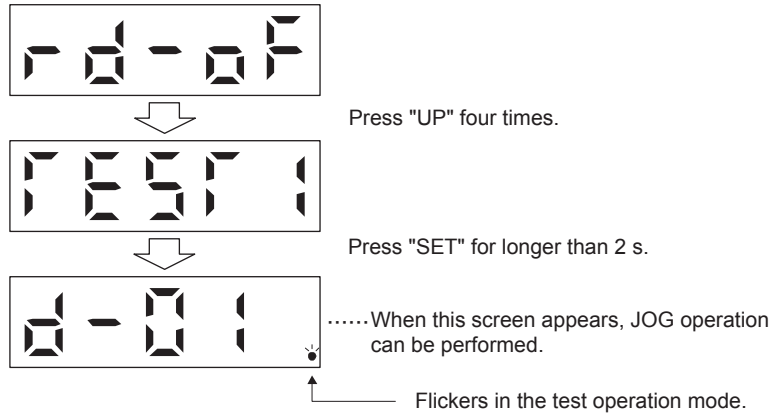

4. STARTUP

(2) JOG operation

| | |
|-------|--|
| POINT | <p>● When performing JOG operation, turn on EM2, LSP and LSN. LSP and LSN can be set to automatic on by setting [Pr. PD01] to " _ C _ _ ".</p> |
|-------|--|

JOG operation can be performed when there is no command from the controller.

(a) Operation

The servo motor rotates while holding down the "UP" or the "DOWN" button. The servo motor stops rotating by releasing the button. The operation condition can be changed using MR Configurator2. The initial operation condition and setting range for operation are listed below.

| Item | Initial setting | Setting range |
|--|-----------------|--------------------------------------|
| Speed [r/min] | 200 | 0 to instantaneous permissible speed |
| Acceleration/deceleration time constant [ms] | 1000 | 0 to 50000 |

The following table shows how to use the buttons.

| Button | Description |
|--------|--|
| "UP" | Press to start CCW rotation. Release to stop. |
| "DOWN" | Press to start CW rotation. Release to stop. |

If the USB cable is disconnected during JOG operation using the MR Configurator2, the servo motor decelerates to a stop.

(b) Status display

You can confirm the servo status during jog operation.

Pressing the "MODE" button in the jog operation-ready status calls the status display screen. With this screen being shown, perform JOG operation with the "UP" or "DOWN" button. Every time the "MODE" button is pushed, the next status display screen appears. When one cycle of the screen display is complete, it returns to the jog operation-ready status screen. Refer to section 4.5.3 for details of status display. Note that the status display screen cannot be changed by "UP" or "DOWN" button in the test operation mode.

(c) Termination of JOG operation

To end the JOG operation, shut the power off once, or press the "MODE" button to switch to the next screen, and then hold down the "SET" button for 2 s or longer.



4. STARTUP

(3) Positioning operation

| |
|--|
| POINT |
| <ul style="list-style-type: none"> ● MR Configurator2 is required to perform positioning operation. ● Turn on EM2 (forced stop 2) when performing positioning operation. |

Positioning operation can be performed when there is no command from an external controller.

(a) Operation

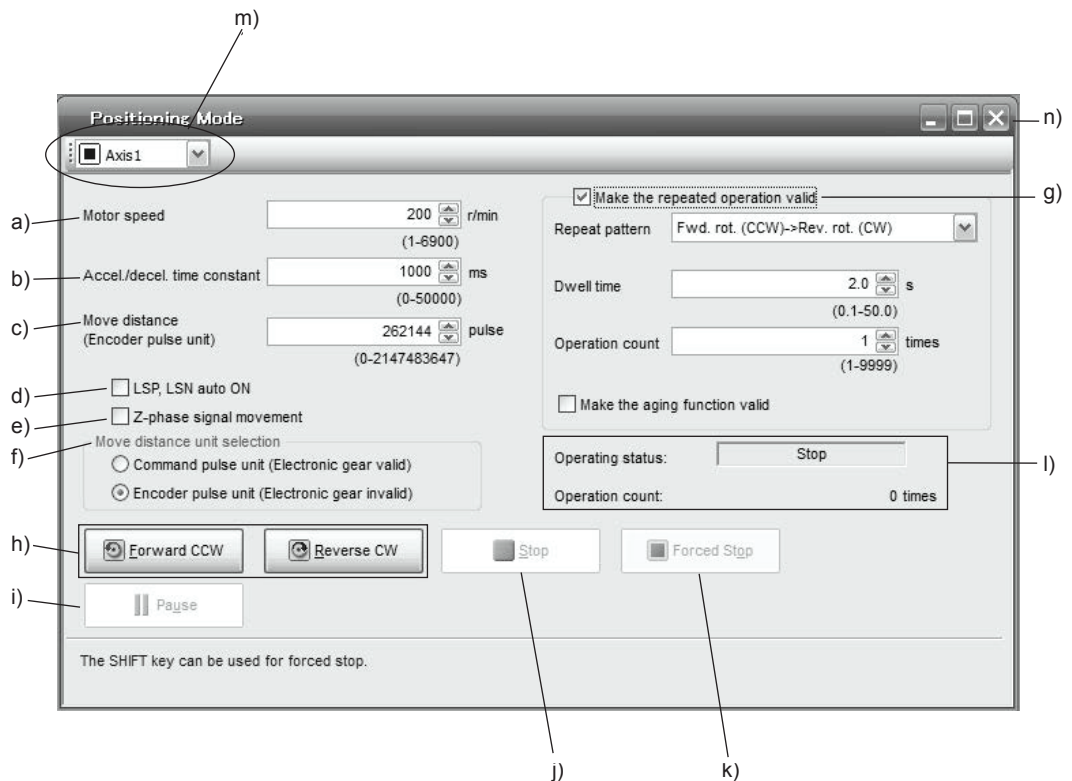

a) Motor speed [r/min]

Enter the servo motor speed into the "Motor speed" input field.

b) Acceleration/deceleration time constant [ms]

Enter the acceleration/deceleration time constant into the "Accel./decel time" input field.

c) Travel distance [pulse]

Enter the travel distance into the "Travel distance" input field.

d) LSP/LSN are automatically turned on

When setting the external stroke signal to automatic on, click the check box to enable it. When it is not checked, turn on LSP and LSN externally.

e) Move till Z-phase signal

Travel is made until the travel distance is reached and the first Z-phase signal in the travelling direction turns on.

4. STARTUP

f) Travel distance unit selection

Select with the option buttons whether the travel distance set in c) is in the command pulse unit or in the encoder pulse unit.

When the command input pulse unit is selected, the value, which is the set travel distance multiplied by the electronic gear, will be the command value. When the encoder pulse unit is selected, the travel distance is not multiplied by the electronic gear.

g) Enable repeat operation

To perform repeat operation, click the check. The initial setting and setting range for the repeat operation are listed below.

| Item | Initial setting | Setting range |
|------------------------------|-----------------------------------|--|
| Repeat pattern | Fwd. rot. (CCW) to rev. rot. (CW) | Fwd. rot. (CCW) to rev. rot. (CW) Fwd. rot. (CCW) to fwd. rot. (CCW) Rev. rot. (CW) to fwd. rot. (CCW) Rev. rot. (CW) to rev. rot. (CW) |
| Dwell time [s] | 2.0 | 01 to 50.0 |
| Number of operations [times] | 1 | 1 to 9999 |

To perform continuous operation with the repeat pattern and dwell time settings, which are set by referring to the above table, click the check box of "Make the aging function enabled".

h) Forward/reverse the servo motor

Click the "Forward" button to rotate the servo motor in the forward rotation direction.
Click the "Reverse" button to rotate the servo motor in the reverse rotation direction.

i) Pause the servo motor

Click the "Pause" button during servo motor rotation to temporarily stop the servo motor.
This button is enabled during servo motor rotation.

h) Stop the servo motor

Click the "Stop" button during servo motor rotation to stop the servo motor.

k) Forced stop

Click the "Forced stop" button during servo motor rotation to make a sudden stop.
This button is enabled during servo motor rotation.

l) Operation status

The operation status during the repeat operation, and the number of operations are displayed

m) Axis No.

Axis No. in operation is displayed.

n) Termination of positioning operation window

Click the close button to cancel the positioning operation mode and close the window.

(b) Status display

The status display can be monitored during positioning operation.

4. STARTUP

(4) Motor-less operation

Without connecting the servo motor, output signals or status display can be provided in response to the input device as if the servo motor is actually running. This operation can be used to check the sequence of a programmable controller or the like.

(a) Operation

Turn off SON (Servo-on), and then select motor-less operation. After that, perform external operation as in ordinary operation.

(b) Start of motor-less operation

After setting "___ 1" in [Pr. PC60], cycle the power. After that, perform external operation as in ordinary operation.

(c) Termination of motor-less operation

To terminate the motor-less operation, set [Pr. PC60] to "___ 0" and then turn the power off.

(5) Program operation

Positioning operation can be performed in two or more operation patterns combined, without using a controller. Use this operation with the forced stop reset. This operation may be used independently of whether servo-on or servo-off and whether a controller is connected or not.

Exercise control on the program operation screen of MR Configurator2. For full information, refer to the MR Configurator2 Installation Guide.

| Operation | Screen control |
|-------------|-------------------------------------|
| Start | Click the "Operation start" button. |
| Stop | Click the "Stop" button. |
| Forced stop | Click the "Forced stop" button. |

(6) Output signal (DO) forced output

Output signals can be switched on/off forcibly independently of the servo status. This function is used for output signal wiring check, etc. Exercise control on the DO forced output screen of MR Configurator2.

5. PARAMETERS

5. PARAMETERS

| | |
|--|---|
|  CAUTION | <ul style="list-style-type: none"> ● Never adjust or change the parameter values extremely as it will make operation unstable. |
| | <ul style="list-style-type: none"> ● If fixed values are written in the digits of a parameter, do not change these values. |
| | <ul style="list-style-type: none"> ● Do not change parameters for manufacturer setting. |

5.1 Parameter list

| |
|--|
| POINT |
| <ul style="list-style-type: none"> ● To enable a parameter whose symbol is preceded by *, cycle the power after setting it. ● The symbols in the control mode column mean as follows. P: Position control mode S: Speed control mode T: Torque control mode |

5.1.1 Basic setting parameters ([Pr. PA_ _])

| No. | Symbol | Name | Initial value | Unit | Control mode | | |
|------|--------|--|---------------|-------------|--------------|---|---|
| | | | | | P | S | T |
| PA01 | *STY | Operation mode | 1000h | | ○ | ○ | ○ |
| PA02 | *REG | Regenerative option | 0000h | | ○ | ○ | ○ |
| PA03 | *ABS | Absolute position detection system | 0000h | | ○ | | |
| PA04 | *AOP1 | Function selection A-1 | 2000h | | ○ | ○ | |
| PA05 | *FBP | Number of command input pulses per revolution | 10000 | | ○ | | |
| PA06 | CMX | Electronic gear numerator (command pulse multiplication numerator) | 1 | | ○ | | |
| PA07 | CDV | Electronic gear denominator (command pulse multiplication denominator) | 1 | | ○ | | |
| PA08 | ATU | Auto tuning mode | 0001h | | ○ | ○ | |
| PA09 | RSP | Auto tuning response | 16 | | ○ | ○ | |
| PA10 | INP | In-position range | 100 | [pulse] | ○ | | |
| PA11 | TLP | Forward rotation torque limit | 100.0 | [%] | ○ | ○ | ○ |
| PA12 | TLN | Reverse rotation torque limit | 100.0 | [%] | ○ | ○ | ○ |
| PA13 | *PLSS | Command pulse input form | 0100h | | ○ | | |
| PA14 | *POL | Rotation direction selection | 0 | | ○ | | |
| PA15 | *ENR | Encoder output pulses | 4000 | [pulse/rev] | ○ | ○ | ○ |
| PA16 | *ENR2 | Encoder output pulses 2 | 1 | | ○ | ○ | ○ |
| PA17 | | For manufacturer setting | 0000h | | | | |
| PA18 | | | 0000h | | | | |
| PA19 | *BLK | Parameter writing inhibit | 00AAh | | ○ | ○ | ○ |
| PA20 | *TDS | Tough drive setting | 0000h | | ○ | ○ | ○ |
| PA21 | *AOP3 | Function selection A-3 | 0001h | | ○ | ○ | |
| PA22 | | For manufacturer setting | 0000h | | | | |
| PA23 | DRAT | Drive recorder arbitrary alarm trigger setting | 0000h | | ○ | ○ | ○ |
| PA24 | AOP4 | Function selection A-4 | 0000h | | ○ | ○ | |
| PA25 | | For manufacturer setting | 0 | | | | |
| PA26 | | | 0000h | | | | |
| PA27 | | | 0000h | | | | |
| PA28 | | | 0000h | | | | |
| PA29 | | | 0000h | | | | |
| PA30 | | | 0000h | | | | |
| PA31 | | | 0000h | | | | |
| PA32 | | | 0000h | | | | |

5. PARAMETERS

5.1.2 Gain/filter setting parameters ([Pr. PB_ _])

| No. | Symbol | Name | Initial value | Unit | Control mode | | |
|------|--------|---|---------------|--------------------------------|--------------|---|---|
| | | | | | P | S | T |
| PB01 | FILT | Adaptive tuning mode (adaptive filter II) | 0000h | | ○ | ○ | ○ |
| PB02 | VRFT | Vibration suppression control tuning mode (advanced vibration suppression control II) | 0000h | | ○ | | |
| PB03 | PST | Position command acceleration/deceleration time constant (position smoothing) | 0 | [ms] | ○ | | |
| PB04 | FFC | Feed forward gain | 0 | [%] | ○ | | |
| PB05 | | For manufacturer setting | 500 | | | | |
| PB06 | GD2 | Load to motor inertia ratio | 7.00 | [Multiplier] | ○ | ○ | |
| PB07 | PG1 | Model loop gain | 15.0 | [rad/s] | ○ | ○ | |
| PB08 | PG2 | Position loop gain | 37.0 | [rad/s] | ○ | | |
| PB09 | VG2 | Speed loop gain | 823 | [rad/s] | ○ | ○ | |
| PB10 | VIC | Speed integral compensation | 33.7 | [ms] | ○ | ○ | |
| PB11 | VDC | Speed differential compensation | 980 | | ○ | ○ | |
| PB12 | OVA | Overshoot amount compensation | 0 | [%] | ○ | | |
| PB13 | NH1 | Machine resonance suppression filter 1 | 4500 | [Hz] | ○ | ○ | ○ |
| PB14 | NHQ1 | Notch shape selection 1 | 0000h | | ○ | ○ | ○ |
| PB15 | NH2 | Machine resonance suppression filter 2 | 4500 | [Hz] | ○ | ○ | ○ |
| PB16 | NHQ2 | Notch shape selection 2 | 0000h | | ○ | ○ | ○ |
| PB17 | NHF | Shaft resonance suppression filter | 0000h | | ○ | ○ | ○ |
| PB18 | LPF | Low-pass filter setting | 3141 | [rad/s] | ○ | ○ | |
| PB19 | VRF11 | Vibration suppression control 1 - Vibration frequency | 100.0 | [Hz] | ○ | | |
| PB20 | VRF12 | Vibration suppression control 1 - Resonance frequency | 100.0 | [Hz] | ○ | | |
| PB21 | VRF13 | Vibration suppression control 1 - Vibration frequency damping | 0.00 | | ○ | | |
| PB22 | VRF14 | Vibration suppression control 1 - Resonance frequency damping | 0.00 | | ○ | | |
| PB23 | VFBF | Low-pass filter selection | 0000h | | ○ | ○ | ○ |
| PB24 | *MVS | Slight vibration suppression control | 0000h | | ○ | | |
| PB25 | *BOP1 | Function selection B-1 | 0000h | | ○ | | |
| PB26 | *CDP | Gain switching function | 0000h | | ○ | ○ | |
| PB27 | CDL | Gain switching condition | 10 | [kpps]/ [pulse]/ [r/min] | ○ | ○ | |
| PB28 | CDT | Gain switching time constant | 1 | [ms] | ○ | ○ | |
| PB29 | GD2B | Load to motor inertia ratio after gain switching | 7.00 | [Multiplier] | ○ | ○ | |
| PB30 | PG2B | Position loop gain after gain switching | 0.0 | [rad/s] | ○ | | |
| PB31 | VG2B | Speed loop gain after gain switching | 0 | [rad/s] | ○ | ○ | |
| PB32 | VICB | Speed integral compensation after gain switching | 0.0 | [ms] | ○ | ○ | |
| PB33 | VRF1B | Vibration suppression control 1 - Vibration frequency after gain switching | 0.0 | [Hz] | ○ | | |
| PB34 | VRF2B | Vibration suppression control 1 - Resonance frequency after gain switching | 0.0 | [Hz] | ○ | | |
| PB35 | VRF3B | Vibration suppression control 1 - Vibration frequency damping after gain switching | 0.00 | | ○ | | |
| PB36 | VRF4B | Vibration suppression control 1 - Resonance frequency damping after gain switching | 0.00 | | ○ | | |
| PB37 | | For manufacturer setting | 1600 | | | | |
| PB38 | | | 0.00 | | | | |
| PB39 | | | 0.00 | | | | |
| PB40 | | | 0.00 | | | | |
| PB41 | | | 0000h | | | | |
| PB42 | | | 0000h | | | | |
| PB43 | | | 0000h | | | | |
| PB44 | | | 0.00 | | | | |
| PB45 | CNHF | Command notch filter | 0000h | | ○ | | |
| PB46 | NH3 | Machine resonance suppression filter 3 | 4500 | [Hz] | ○ | ○ | ○ |
| PB47 | NHQ3 | Notch shape selection 3 | 0000h | | ○ | ○ | ○ |
| PB48 | NH4 | Machine resonance suppression filter 4 | 4500 | [Hz] | ○ | ○ | ○ |

5. PARAMETERS

| No. | Symbol | Name | Initial value | Unit | Control mode | | |
|------|--------|--|---------------|---------|--------------|---|---|
| | | | | | P | S | T |
| PB49 | NHQ4 | Notch shape selection 4 | 0000h | | ○ | ○ | ○ |
| PB50 | NH5 | Machine resonance suppression filter 5 | 4500 | [Hz] | ○ | ○ | ○ |
| PB51 | NHQ5 | Notch shape selection 5 | 0000h | | ○ | ○ | ○ |
| PB52 | VRF21 | Vibration suppression control 2 - Vibration frequency | 100.0 | [Hz] | ○ | △ | △ |
| PB53 | VRF22 | Vibration suppression control 2 - Resonance frequency | 100.0 | [Hz] | ○ | △ | △ |
| PB54 | VRF23 | Vibration suppression control 2 - Vibration frequency damping | 0.00 | | ○ | △ | △ |
| PB55 | VRF24 | Vibration suppression control 2 - Resonance frequency damping | 0.00 | | ○ | △ | △ |
| PB56 | VRF21B | Vibration suppression control 2 - Vibration frequency after gain switching | 0.0 | [Hz] | ○ | △ | △ |
| PB57 | VRF22B | Vibration suppression control 2 - Resonance frequency after gain switching | 0.0 | [Hz] | ○ | △ | △ |
| PB58 | VRF23B | Vibration suppression control 2 - Vibration frequency damping after gain switching | 0.00 | | ○ | △ | △ |
| PB59 | VRF24B | Vibration suppression control 2 - Resonance frequency damping after gain switching | 0.00 | | ○ | △ | △ |
| PB60 | PG1B | Model loop gain after gain switching | 0.0 | [rad/s] | ○ | ○ | △ |
| PB61 | | For manufacturer setting | 0.0 | | △ | △ | △ |
| PB62 | | | 0000h | | | | |
| PB63 | | | 0000h | | | | |
| PB64 | | | 0000h | | | | |

5.1.3 Extension setting parameters ([Pr. PC_ _])

| No. | Symbol | Name | Initial value | Unit | Control mode | | |
|------|--------|---|---------------|-----------|--------------|---|---|
| | | | | | P | S | T |
| PC01 | STA | Acceleration time constant | 0 | [ms] | △ | ○ | ○ |
| PC02 | STB | Deceleration time constant | 0 | [ms] | △ | ○ | ○ |
| PC03 | STC | S-pattern acceleration/deceleration time constant | 0 | [ms] | △ | ○ | ○ |
| PC04 | TQC | Torque command time constant | 0 | [ms] | △ | △ | ○ |
| PC05 | SC1 | Internal speed command 1 | 100 | [r/min] | △ | ○ | △ |
| | | Internal speed limit 1 | | | △ | △ | ○ |
| PC06 | SC2 | Internal speed command 2 | 500 | [r/min] | △ | ○ | △ |
| | | Internal speed limit 2 | | | △ | △ | ○ |
| PC07 | SC3 | Internal speed command 3 | 1000 | [r/min] | △ | ○ | △ |
| | | Internal speed limit 3 | | | △ | △ | ○ |
| PC08 | SC4 | Internal speed command 4 | 200 | [r/min] | △ | ○ | △ |
| | | Internal speed limit 4 | | | △ | △ | ○ |
| PC09 | SC5 | Internal speed command 5 | 300 | [r/min] | △ | ○ | △ |
| | | Internal speed limit 5 | | | △ | △ | ○ |
| PC10 | SC6 | Internal speed command 6 | 500 | [r/min] | △ | ○ | △ |
| | | Internal speed limit 6 | | | △ | △ | ○ |
| PC11 | SC7 | Internal speed command 7 | 800 | [r/min] | △ | ○ | △ |
| | | Internal speed limit 7 | | | △ | △ | ○ |
| PC12 | VCM | Analog speed command - Maximum speed | 0 | [r/min] | △ | ○ | △ |
| | | Analog speed limit - Maximum speed | | | △ | △ | ○ |
| PC13 | TLC | Analog torque command maximum output | 100.0 | [%] | △ | △ | ○ |
| PC14 | MOD1 | Analog monitor 1 output | 0000h | | ○ | ○ | ○ |
| PC15 | MOD2 | Analog monitor 2 output | 0001h | | ○ | ○ | ○ |
| PC16 | MBR | Electromagnetic brake sequence output | 0 | [ms] | ○ | ○ | ○ |
| PC17 | ZSP | Zero speed | 50 | [r/min] | ○ | ○ | ○ |
| PC18 | *BPS | Alarm history clear | 0000h | | ○ | ○ | ○ |
| PC19 | *ENRS | Encoder output pulse selection | 0000h | | ○ | ○ | ○ |
| PC20 | *SNO | Station number setting | 0 | [station] | ○ | ○ | ○ |
| PC21 | | For manufacturer setting | 0000h | | △ | △ | △ |
| PC22 | | | *COP1 | | | | |
| PC23 | *COP2 | Function selection C-2 | 0000h | | △ | ○ | ○ |

5. PARAMETERS

| No. | Symbol | Name | Initial value | Unit | Control mode | | |
|------|--------|---|---------------|--------------|--------------|---|---|
| | | | | | P | S | T |
| PC24 | *COP3 | Function selection C-3 | 0000h | | ○ | | |
| PC25 | | For manufacturer setting | 0000h | | | | |
| PC26 | *COP5 | Function selection C-5 | 0000h | | ○ | ○ | |
| PC27 | *COP6 | Function selection C-6 | 0000h | | ○ | ○ | ○ |
| PC28 | | For manufacturer setting | 0000h | | | | |
| PC29 | | | 0000h | | | | |
| PC30 | STA2 | Acceleration time constant 2 | 0 | [ms] | | ○ | ○ |
| PC31 | STB2 | Deceleration time constant 2 | 0 | [ms] | | ○ | ○ |
| PC32 | CMX2 | Command input pulse multiplication numerator 2 | 1 | | ○ | | |
| PC33 | CMX3 | Command input pulse multiplication numerator 3 | 1 | | ○ | | |
| PC34 | CMX4 | Command input pulse multiplication numerator 4 | 1 | | ○ | | |
| PC35 | TL2 | Internal torque limit 2 | 100.0 | [%] | ○ | ○ | ○ |
| PC36 | *DMD | Status display selection | 0000h | | ○ | ○ | ○ |
| PC37 | VCO | Analog speed command offset | 0 | [mV] | | ○ | |
| | | Analog speed limit offset | | | | | |
| PC38 | TPO | Analog torque command offset | 0 | [mV] | | | ○ |
| | | Analog torque limit offset | | | | | ○ |
| PC39 | MO1 | Analog monitor 1 offset | 0 | [mV] | ○ | ○ | ○ |
| PC40 | MO2 | Analog monitor 2 offset | 0 | [mV] | ○ | ○ | ○ |
| PC41 | | For manufacturer setting | 0 | | | | |
| PC42 | | | 0 | | | | |
| PC43 | ERZ | Error excessive alarm detection level | 0 | [rev] | ○ | | |
| PC44 | | For manufacturer setting | 0000h | | | | |
| PC45 | | | 0000h | | | | |
| PC46 | | | 0 | | | | |
| PC47 | | | 0 | | | | |
| PC48 | | | 0 | | | | |
| PC49 | | | 0 | | | | |
| PC50 | | | 0000h | | | | |
| PC51 | RSBR | Forced stop deceleration time constant | 100 | [ms] | ○ | ○ | |
| PC52 | | For manufacturer setting | 0 | | | | |
| PC53 | | | 0 | | | | |
| PC54 | RSUP1 | Vertical axis freefall prevention compensation amount | 0 | [0.0001 rev] | ○ | | |
| PC55 | | For manufacturer setting | 0 | | | | |
| PC56 | | | 100 | | | | |
| PC57 | | | 0000h | | | | |
| PC58 | | | 0 | | | | |
| PC59 | | | 0000h | | | | |
| PC60 | *COPD | Function selection C-D | 0000h | | ○ | ○ | ○ |
| PC61 | | For manufacturer setting | 0000h | | | | |
| PC62 | | | 0000h | | | | |
| PC63 | | | 0000h | | | | |
| PC64 | | | 0000h | | | | |
| PC65 | | | 0000h | | | | |
| PC66 | | | 0000h | | | | |
| PC67 | | | 0000h | | | | |
| PC68 | | | 0000h | | | | |
| PC69 | | | 0000h | | | | |
| PC70 | | | 0000h | | | | |
| PC71 | | | 0000h | | | | |
| PC72 | | | 0000h | | | | |
| PC73 | | | 0000h | | | | |
| PC74 | | | 0000h | | | | |
| PC75 | | | 0000h | | | | |
| PC76 | | | 0000h | | | | |

5. PARAMETERS

| No. | Symbol | Name | Initial value | Unit | Control mode | | |
|------|--------|--------------------------|---------------|------|--------------|---|---|
| | | | | | P | S | T |
| PC77 | | For manufacturer setting | 0000h | | | | |
| PC78 | | | 0000h | | | | |
| PC79 | | | 0000h | | | | |
| PC80 | | | 0000h | | | | |

5.1.4 I/O setting parameters ([Pr. PD_ _])

| No. | Symbol | Name | Initial value | Unit | Control mode | | |
|------|--------|---------------------------------------|---------------|------|--------------|---|---|
| | | | | | P | S | T |
| PD01 | *DIA1 | Input signal automatic on selection 1 | 0000h | | | | |
| PD02 | | For manufacturer setting | 0000h | | | | |
| PD03 | *DI1L | Input device selection 1L | 0202h | | | | |
| PD04 | *DI1H | Input device selection 1H | 0000h | | | | |
| PD05 | *DI2L | Input device selection 2L | 0000h | | | | |
| PD06 | *DI2H | Input device selection 2H | 0021h | | | | |
| PD07 | *DI3L | Input device selection 3L | 0000h | | | | |
| PD08 | *DI3H | Input device selection 3H | 0000h | | | | |
| PD09 | *DI4L | Input device selection 4L | 0000h | | | | |
| PD10 | *DI4H | Input device selection 4H | 0000h | | | | |
| PD11 | *DI5L | Input device selection 5L | 0303h | | | | |
| PD12 | *DI5H | Input device selection 5H | 0003h | | | | |
| PD13 | *DI6L | Input device selection 6L | 2006h | | | | |
| PD14 | *DI6H | Input device selection 6H | 0020h | | | | |
| PD15 | | For manufacturer setting | 0000h | | | | |
| PD16 | | | 0000h | | | | |
| PD17 | *DI8L | Input device selection 8L | 0A0Ah | | | | |
| PD18 | *DI8H | Input device selection 8H | 0000h | | | | |
| PD19 | *DI9L | Input device selection 9L | 0B0Bh | | | | |
| PD20 | *DI9H | Input device selection 9H | 0000h | | | | |
| PD21 | *DI10L | Input device selection 10L | 2323h | | | | |
| PD22 | *DI10H | Input device selection 10H | 0023h | | | | |
| PD23 | *DO1 | Output device selection 1 | 0004h | | | | |
| PD24 | *DO2 | Output device selection 2 | 000Ch | | | | |
| PD25 | *DO3 | Output device selection 3 | 0004h | | | | |
| PD26 | *DO4 | Output device selection 4 | 0007h | | | | |
| PD27 | | For manufacturer setting | 0003h | | | | |
| PD28 | *DO6 | Output device selection 6 | 0002h | | | | |
| PD29 | *DIF | Input filter setting | 0004h | | | | |
| PD30 | *DOP1 | Function selection D-1 | 0000h | | | | |
| PD31 | | For manufacturer setting | 0000h | | | | |
| PD32 | *DOP3 | Function selection D-3 | 0000h | | | | |
| PD33 | | For manufacturer setting | 0000h | | | | |
| PD34 | DOP5 | Function selection D-5 | 0000h | | | | |
| PD35 | | For manufacturer setting | 0000h | | | | |
| PD36 | | | 0000h | | | | |
| PD37 | | | 0000h | | | | |
| PD38 | | | 0 | | | | |
| PD39 | | | 0 | | | | |
| PD40 | | | 0 | | | | |
| PD41 | | | 0000h | | | | |
| PD42 | | | 0000h | | | | |
| PD43 | | | 0000h | | | | |
| PD44 | | | 0000h | | | | |
| PD45 | | | 0000h | | | | |

5. PARAMETERS

| No. | Symbol | Name | Initial value | Unit | Control mode | | |
|------|--------|--------------------------|---------------|------|--------------|---|---|
| | | | | | P | S | T |
| PD46 | | For manufacturer setting | 0000h | | | | |
| PD47 | | | 0000h | | | | |
| PD48 | | | 0000h | | | | |

5.1.5 Extension setting 2 parameters ([Pr. PE_ _])

| No. | Symbol | Name | Initial value | Unit | Control mode | | | |
|------|--------|--------------------------|---------------|------|--------------|---|---|---|
| | | | | | P | S | T | |
| PE01 | | For manufacturer setting | 0000h | | | | | |
| PE02 | | | 0000h | | | | | |
| PE03 | | | 0003h | | | | | |
| PE04 | | | 1 | | | | | |
| PE05 | | | 1 | | | | | |
| PE06 | | | 400 | | | | | |
| PE07 | | | 100 | | | | | |
| PE08 | | | 10 | | | | | |
| PE09 | | | 0000h | | | | | |
| PE10 | | | 0000h | | | | | |
| PE11 | | | 0000h | | | | | |
| PE12 | | | 0000h | | | | | |
| PE13 | | | 0000h | | | | | |
| PE14 | | | 0111h | | | | | |
| PE15 | | | 20 | | | | | |
| PE16 | | | 0000h | | | | | |
| PE17 | | | 0000h | | | | | |
| PE18 | | | 0000h | | | | | |
| PE19 | | | 0000h | | | | | |
| PE20 | | | 0000h | | | | | |
| PE21 | | | 0000h | | | | | |
| PE22 | | | 0000h | | | | | |
| PE23 | | | 0000h | | | | | |
| PE24 | | | 0000h | | | | | |
| PE25 | | | 0000h | | | | | |
| PE26 | | | 0000h | | | | | |
| PE27 | | | 0000h | | | | | |
| PE28 | | | 0000h | | | | | |
| PE29 | | | 0000h | | | | | |
| PE30 | | | 0000h | | | | | |
| PE31 | | | 0000h | | | | | |
| PE32 | | | 0000h | | | | | |
| PE33 | | | 0000h | | | | | |
| PE34 | | | 1 | | | | | |
| PE35 | | | 1 | | | | | |
| PE36 | | | 0.0 | | | | | |
| PE37 | | | 0.00 | | | | | |
| PE38 | | | 0.00 | | | | | |
| PE39 | | | 20 | | | | | |
| PE40 | | | 0000h | | | | | |
| PE41 | EOP3 | Function selection E-3 | 0000h | | | ○ | ○ | ○ |
| PE42 | | For manufacturer setting | 0 | | | | | |
| PE43 | | | 0.0 | | | | | |
| PE44 | | | 0000h | | | | | |
| PE45 | | | 0000h | | | | | |
| PE46 | 0000h | | | | | | | |

5. PARAMETERS

| No. | Symbol | Name | Initial value | Unit | Control mode | | |
|------|--------|--------------------------|---------------|------|--------------|---|---|
| | | | | | P | S | T |
| PE47 | | For manufacturer setting | 0000h | | | | |
| PE48 | | | 0000h | | | | |
| PE49 | | | 0000h | | | | |
| PE50 | | | 0000h | | | | |
| PE51 | | | 0000h | | | | |
| PE52 | | | 0000h | | | | |
| PE53 | | | 0000h | | | | |
| PE54 | | | 0000h | | | | |
| PE55 | | | 0000h | | | | |
| PE56 | | | 0000h | | | | |
| PE57 | | | 0000h | | | | |
| PE58 | | | 0000h | | | | |
| PE59 | | | 0000h | | | | |
| PE60 | | | 0000h | | | | |
| PE61 | | | 0.00 | | | | |
| PE62 | | | 0.00 | | | | |
| PE63 | | | 0.00 | | | | |
| PE64 | | | 0.00 | | | | |

5.1.6 Extension setting 3 parameters ([Pr. PF_ _])

| No. | Symbol | Name | Initial value | Unit | Control mode | | |
|------|--------|--|---------------|---------|--------------|---|---|
| | | | | | P | S | T |
| PF01 | | For manufacturer setting | 0000h | | | | |
| PF02 | | | 0000h | | | | |
| PF03 | | | 0000h | | | | |
| PF04 | | | 0 | | | | |
| PF05 | | | 0 | | | | |
| PF06 | | | 0000h | | | | |
| PF07 | | | 1 | | | | |
| PF08 | | | 1 | | | | |
| PF09 | | | 0000h | | | | |
| PF10 | | | 0000h | | | | |
| PF11 | | | 0000h | | | | |
| PF12 | | | 10000 | | | | |
| PF13 | | | 100 | | | | |
| PF14 | | | 100 | | | | |
| PF15 | | | 2000 | | | | |
| PF16 | | | 0000h | | | | |
| PF17 | | | 10 | | | | |
| PF18 | | | 0000h | | | | |
| PF19 | | | 0000h | | | | |
| PF20 | | | 0000h | | | | |
| PF21 | DRT | Drive recorder switching time setting | 0 | [s] | ○ | ○ | ○ |
| PF22 | | For manufacturer setting | 200 | | | | |
| PF23 | OSCL1 | Vibration tough drive - Oscillation detection level | 50 | [%] | ○ | ○ | |
| PF24 | *OSCL2 | Vibration tough drive function selection | 0000h | | ○ | ○ | |
| PF25 | CVAT | Instantaneous power failure tough drive - Detection time | 200 | [ms] | ○ | ○ | ○ |
| PF26 | | For manufacturer setting | 0 | | | | |
| PF27 | | | 0 | | | | |
| PF28 | | | 0 | | | | |
| PF29 | | | 0000h | | | | |
| PF30 | | | 0 | | | | |
| PF31 | FRIC | Machine diagnosis function - Friction judgement speed | 0 | [r/min] | ○ | ○ | ○ |

5. PARAMETERS

| No. | Symbol | Name | Initial value | Unit | Control mode | | |
|-------|--------|--------------------------|---------------|------|--------------|---|---|
| | | | | | P | S | T |
| PF32 | | For manufacturer setting | 50 | | | | |
| PF33 | | | 0000h | | | | |
| PF34 | | | 0000h | | | | |
| PF 35 | | | 0000h | | | | |
| PF36 | | | 0000h | | | | |
| PF37 | | | 0000h | | | | |
| PF38 | | | 0000h | | | | |
| PF39 | | | 0000h | | | | |
| PF40 | | | 0000h | | | | |
| PF41 | | | 0000h | | | | |
| PF42 | | | 0000h | | | | |
| PF43 | | | 0000h | | | | |
| PF44 | | | 0000h | | | | |
| PF45 | | | 0000h | | | | |
| PF46 | | | 0000h | | | | |
| PF47 | | | 0000h | | | | |
| PF48 | | | 0000h | | | | |

5.2 Detailed list of parameters

| |
|--|
| POINT |
| ● "x" in the "Setting digit" columns means which digit to set a value. |

5.2.1 Basic setting parameters ([Pr. PA_ _])

| No./symbol/name | Setting digit | Function | Initial value [unit] | Control mode | | |
|--------------------------------|---------------|---|----------------------|--------------|---|---|
| | | | | P | S | T |
| PA01 *STY Operation mode | ___x | Control mode selection Select a control mode. 0: Position control mode 1: Position control mode and speed control mode 2: Speed control mode 3: Speed control mode and torque control mode 4: Torque control mode 5: Torque control mode and position control mode | 0h | ○ | ○ | ○ |
| | __x_ | For manufacturer setting | 0h | / | / | / |
| | _x__ | | 0h | / | / | / |
| | x___ | | 1h | / | / | / |

5. PARAMETERS

| No./symbol/name | Setting digit | Function | Initial value [unit] | Control mode | | | | | | | | | | | | | | | |
|---|--|---|---|-----------------------|-----------------------|-----------------------|---------------|---------|---------------------|--|-------------------|----------------|-------|-----|---|---|-------|-----|---|
| | | | | P | S | T | | | | | | | | | | | | | |
| PA02 *REG Regenerative option | __ x x | Regenerative option selection Used to select the regenerative option. Incorrect setting may cause the regenerative option to burn. If a selected regenerative option is not for use with the servo amplifier, [AL. 37 Parameter error] occurs. 00: Regenerative option is not used ▪ For servo amplifier of 100 W, regenerative resistor is not used. ▪ For servo amplifier of 0.2 kW to 7 kW, built-in regenerative resistor is used. 01: FR-RC/FR-CV/FR-BU2 When you use FR-RC, FR-CV, or FR-BU2, select "Mode 2 (__ __ 1)" of "Undervoltage alarm detection mode selection" in [Pr. PC27]. 02: MR-RB032 03: MR-RB12 04: MR-RB32 05: MR-RB30 06: MR-RB50 (Cooling fan is required.) 08: MR-RB31 09: MR-RB51 (Cooling fan is required.) 0B: MR-RB3N 0C: MR-RB5N (Cooling fan is required.) | 00h | <input type="radio"/> | <input type="radio"/> | <input type="radio"/> | | | | | | | | | | | | | |
| | __ x __ | For manufacturer setting | 0h | | | | | | | | | | | | | | | | |
| | x __ __ | | 0h | | | | | | | | | | | | | | | | |
| PA03 *ABS Absolute position detection system | ___ x | Absolute position detection system selection Set this parameter when using the absolute position detection system in the position control mode. 0: Disabled (incremental system) 1: Enabled (absolute position detection system by DIO) | 0h | <input type="radio"/> | | | | | | | | | | | | | | | |
| | __ x _ | For manufacturer setting | 0h | | | | | | | | | | | | | | | | |
| | _ x __ | | 0h | | | | | | | | | | | | | | | | |
| | x __ __ | | 0h | | | | | | | | | | | | | | | | |
| PA04 *AOP1 Function selection A-1 | ___ x | For manufacturer setting | 0h | | | | | | | | | | | | | | | | |
| | __ x _ | | 0h | | | | | | | | | | | | | | | | |
| | _ x __ | | 0h | | | | | | | | | | | | | | | | |
| | x __ __ | Forced stop deceleration function selection 0: Forced stop deceleration function disabled (EM1) 2: Forced stop deceleration function enabled (EM2) Refer to table 5.1 for details. | 2h | <input type="radio"/> | <input type="radio"/> | | | | | | | | | | | | | | |
| | Table 5.1 Deceleration method <table border="1" style="width: 100%; border-collapse: collapse;"> <thead> <tr> <th rowspan="2">Setting value</th> <th rowspan="2">EM2/EM1</th> <th colspan="2">Deceleration method</th> </tr> <tr> <th>EM2 or EM1 is off</th> <th>Alarm occurred</th> </tr> </thead> <tbody> <tr> <td>0 ___</td> <td>EM1</td> <td>MBR (Electromagnetic brake interlock) turns off without the forced stop deceleration.</td> <td>MBR (Electromagnetic brake interlock) turns off without the forced stop deceleration.</td> </tr> <tr> <td>2 ___</td> <td>EM2</td> <td>MBR (Electromagnetic brake interlock) turns off after the forced stop deceleration.</td> <td>MBR (Electromagnetic brake interlock) turns off after the forced stop deceleration.</td> </tr> </tbody> </table> | | | | | | Setting value | EM2/EM1 | Deceleration method | | EM2 or EM1 is off | Alarm occurred | 0 ___ | EM1 | MBR (Electromagnetic brake interlock) turns off without the forced stop deceleration. | MBR (Electromagnetic brake interlock) turns off without the forced stop deceleration. | 2 ___ | EM2 | MBR (Electromagnetic brake interlock) turns off after the forced stop deceleration. |
| Setting value | EM2/EM1 | Deceleration method | | | | | | | | | | | | | | | | | |
| | | EM2 or EM1 is off | Alarm occurred | | | | | | | | | | | | | | | | |
| 0 ___ | EM1 | MBR (Electromagnetic brake interlock) turns off without the forced stop deceleration. | MBR (Electromagnetic brake interlock) turns off without the forced stop deceleration. | | | | | | | | | | | | | | | | |
| 2 ___ | EM2 | MBR (Electromagnetic brake interlock) turns off after the forced stop deceleration. | MBR (Electromagnetic brake interlock) turns off after the forced stop deceleration. | | | | | | | | | | | | | | | | |
| PA05 *FBP Number of command input pulses per revolution | | The servo motor rotates based on set command input pulses. To enable the parameter value, select "Number of command input pulses per revolution (1 ___)" of "Electronic gear selection" in [Pr. PA21]. Setting range: 1000 to 1000000 | 10000 | <input type="radio"/> | | | | | | | | | | | | | | | |

5. PARAMETERS

| No./symbol/name | Setting digit | Function | Initial value [unit] | Control mode | | |
|---|---------------|---|----------------------|-----------------------|-----------------------|---|
| | | | | P | S | T |
| PA06 CMX Electronic gear numerator (command pulse multiplication numerator) | | <p>Set the numerator of the electronic gear.</p> <p>To enable the parameter, select "Electronic gear (0 ___)" or "J3A electronic gear setting value compatibility mode (2 ___)" of "Electronic gear selection" in [Pr. PA21].</p> <p>The following shows a standard of the setting range of the electronic gear.</p> $\frac{1}{10} < \frac{\text{CMX}}{\text{CDV}} < 4000$ <p>If the set value is outside this range, noise may be generated during acceleration/deceleration or operation may not be performed at the preset speed and/or acceleration/deceleration time constants.</p> <p>Number of command input pulses per revolution (Pr. PA05) "1000" to "1000000"</p> <p>Electronic gear selection (x ___) (Pr. PA21)</p> <p>Electronic gear (Pr. PA06)/[Pr. PA07]</p> <p>Command pulse train</p> <p>"0" (initial value)</p> <p>"1"</p> <p>"2"</p> <p>X16</p> <p>Pt FBP</p> <p>CMX CDV</p> <p>CMX CDV</p> <p>Deviation counter</p> <p>Servo motor</p> <p>Encoder</p> <p>Pt (servo motor resolution): 4194304 [pulse/rev]</p> <p>Always set the electronic gear with servo-off state to prevent unexpected operation due to improper setting.</p> <p>Setting range: 1 to 16777215</p> | 1 | <input type="radio"/> | | |
| PA07 CDV Electronic gear denominator (command pulse multiplication denominator) | | <p>Set the denominator of the electronic gear.</p> <p>To enable the parameter, select "Electronic gear (0 ___)" or "J3A electronic gear setting value compatibility mode (2 ___)" of "Electronic gear selection" in [Pr. PA21].</p> <p>Setting range: 1 to 16777215</p> | 1 | <input type="radio"/> | | |
| PA08 ATU Auto tuning mode | ___ x | <p>Gain adjustment mode selection</p> <p>Select the gain adjustment mode.</p> <p>0: 2 gain adjustment mode 1 (interpolation mode)</p> <p>1: Auto tuning mode 1</p> <p>2: Auto tuning mode 2</p> <p>3: Manual mode</p> <p>4: 2 gain adjustment mode 2</p> <p>Refer to table 5.2 for details.</p> | 1h | <input type="radio"/> | <input type="radio"/> | |
| | __ x _ | For manufacturer setting | 0h | | | |
| | _ x _ _ | | 0h | | | |
| | x _ _ _ | | 0h | | | |







5. PARAMETERS

| No./symbol/name | Setting digit | Function | Initial value [unit] | Control mode | | | | | | | | | | | | | | | | | | | | | | | | | | | | | | | | | | | | | | | | | | | | | | | | | | | | | | | | | | | | | | | | | | | | | | | | | | | | | | | | | | | | | | | | | | | | | | | | | | |
|-------------------------------------|---|---|---|-----------------------|-----------------------|--|---|-------------------|-----|---|-----|---|-----|---|-----|---|------|---|------|---|------|---|------|---|------|----|------|----|------|----|------|----|------|----|------|----|------|----|------|----|------|----|------|----|------|----|------|--|----------------------|--|---|---------------|------------------------|--|----------|--|----|----------------------|------|----|------|----|------|----|------|----|-------|----|-------|----|-------|----|-------|----|-------|----|-------|----|-------|----|-------|----|-------|----|-------|----|-------|----|-------|----|-------|----|-------|----|-------|----|-------|--|--------------------|--|--|--|
| | | | | P | S | T | | | | | | | | | | | | | | | | | | | | | | | | | | | | | | | | | | | | | | | | | | | | | | | | | | | | | | | | | | | | | | | | | | | | | | | | | | | | | | | | | | | | | | | | | | | | | | | | |
| PA08 ATU Auto tuning mode | Table 5.2 Gain adjustment mode selection | | | | | | | | | | | | | | | | | | | | | | | | | | | | | | | | | | | | | | | | | | | | | | | | | | | | | | | | | | | | | | | | | | | | | | | | | | | | | | | | | | | | | | | | | | | | | | | | | | | | | |
| | Setting value | Gain adjustment mode | Automatically adjusted parameter | | | | | | | | | | | | | | | | | | | | | | | | | | | | | | | | | | | | | | | | | | | | | | | | | | | | | | | | | | | | | | | | | | | | | | | | | | | | | | | | | | | | | | | | | | | | | | | | | | | |
| | --- 0 | 2 gain adjustment mode 1 (interpolation mode) | [Pr. PB06 Load to motor inertia ratio] [Pr. PB08 Position loop gain] [Pr. PB09 Speed loop gain] [Pr. PB10 Speed integral compensation] | | | | | | | | | | | | | | | | | | | | | | | | | | | | | | | | | | | | | | | | | | | | | | | | | | | | | | | | | | | | | | | | | | | | | | | | | | | | | | | | | | | | | | | | | | | | | | | | | | | |
| | --- 1 | Auto tuning mode 1 | [Pr. PB06 Load to motor inertia ratio] [Pr. PB07 Model loop gain] [Pr. PB08 Position loop gain] [Pr. PB09 Speed loop gain] [Pr. PB10 Speed integral compensation] | | | | | | | | | | | | | | | | | | | | | | | | | | | | | | | | | | | | | | | | | | | | | | | | | | | | | | | | | | | | | | | | | | | | | | | | | | | | | | | | | | | | | | | | | | | | | | | | | | | |
| | --- 2 | Auto tuning mode 2 | [Pr. PB07 Model loop gain] [Pr. PB08 Position loop gain] [Pr. PB09 Speed loop gain] [Pr. PB10 Speed integral compensation] | | | | | | | | | | | | | | | | | | | | | | | | | | | | | | | | | | | | | | | | | | | | | | | | | | | | | | | | | | | | | | | | | | | | | | | | | | | | | | | | | | | | | | | | | | | | | | | | | | | |
| | --- 3 | Manual mode | | | | | | | | | | | | | | | | | | | | | | | | | | | | | | | | | | | | | | | | | | | | | | | | | | | | | | | | | | | | | | | | | | | | | | | | | | | | | | | | | | | | | | | | | | | | | | | | | | | | |
| --- | 4 | 2 gain adjustment mode 2 | [Pr. PB08 Position loop gain] [Pr. PB09 Speed loop gain] [Pr. PB10 Speed integral compensation] | | | | | | | | | | | | | | | | | | | | | | | | | | | | | | | | | | | | | | | | | | | | | | | | | | | | | | | | | | | | | | | | | | | | | | | | | | | | | | | | | | | | | | | | | | | | | | | | | | | |
| PA09 RSP Auto tuning response | Set a response of the auto tuning. | | 16 | <input type="radio"/> | <input type="radio"/> | | | | | | | | | | | | | | | | | | | | | | | | | | | | | | | | | | | | | | | | | | | | | | | | | | | | | | | | | | | | | | | | | | | | | | | | | | | | | | | | | | | | | | | | | | | | | | | | | |
| | <table border="1"> <thead> <tr> <th rowspan="2">Setting value</th> <th colspan="2">Machine characteristic</th> </tr> <tr> <th>Response</th> <th>Guideline for machine resonance frequency [Hz]</th> </tr> </thead> <tbody> <tr><td>1</td><td rowspan="16" style="text-align: center;">Low response ↑</td><td>2.7</td></tr> <tr><td>2</td><td>3.6</td></tr> <tr><td>3</td><td>4.9</td></tr> <tr><td>4</td><td>6.6</td></tr> <tr><td>5</td><td>10.0</td></tr> <tr><td>6</td><td>11.3</td></tr> <tr><td>7</td><td>12.7</td></tr> <tr><td>8</td><td>14.3</td></tr> <tr><td>9</td><td>16.1</td></tr> <tr><td>10</td><td>18.1</td></tr> <tr><td>11</td><td>20.4</td></tr> <tr><td>12</td><td>23.0</td></tr> <tr><td>13</td><td>25.9</td></tr> <tr><td>14</td><td>29.2</td></tr> <tr><td>15</td><td>32.9</td></tr> <tr><td>16</td><td>37.0</td></tr> <tr><td>17</td><td>41.7</td></tr> <tr><td>18</td><td>47.0</td></tr> <tr><td>19</td><td>52.9</td></tr> <tr><td>20</td><td>59.6</td></tr> <tr><td></td><td style="text-align: center;">↓ Middle response</td><td></td></tr> </tbody> </table> | Setting value | Machine characteristic | | Response | Guideline for machine resonance frequency [Hz] | 1 | Low response ↑ | 2.7 | 2 | 3.6 | 3 | 4.9 | 4 | 6.6 | 5 | 10.0 | 6 | 11.3 | 7 | 12.7 | 8 | 14.3 | 9 | 16.1 | 10 | 18.1 | 11 | 20.4 | 12 | 23.0 | 13 | 25.9 | 14 | 29.2 | 15 | 32.9 | 16 | 37.0 | 17 | 41.7 | 18 | 47.0 | 19 | 52.9 | 20 | 59.6 | | ↓ Middle response | | <table border="1"> <thead> <tr> <th rowspan="2">Setting value</th> <th colspan="2">Machine characteristic</th> </tr> <tr> <th>Response</th> <th>Guideline for machine resonance frequency [Hz]</th> </tr> </thead> <tbody> <tr><td>21</td><td rowspan="20" style="text-align: center;">Middle response ↑</td><td>67.1</td></tr> <tr><td>22</td><td>75.6</td></tr> <tr><td>23</td><td>85.2</td></tr> <tr><td>24</td><td>95.9</td></tr> <tr><td>25</td><td>108.0</td></tr> <tr><td>26</td><td>121.7</td></tr> <tr><td>27</td><td>137.1</td></tr> <tr><td>28</td><td>154.4</td></tr> <tr><td>29</td><td>173.9</td></tr> <tr><td>30</td><td>195.9</td></tr> <tr><td>31</td><td>220.6</td></tr> <tr><td>32</td><td>248.5</td></tr> <tr><td>33</td><td>279.9</td></tr> <tr><td>34</td><td>315.3</td></tr> <tr><td>35</td><td>355.1</td></tr> <tr><td>36</td><td>400.0</td></tr> <tr><td>37</td><td>446.6</td></tr> <tr><td>38</td><td>501.2</td></tr> <tr><td>39</td><td>571.5</td></tr> <tr><td>40</td><td>642.7</td></tr> <tr><td></td><td style="text-align: center;">↓ High response</td><td></td></tr> </tbody> </table> | Setting value | Machine characteristic | | Response | Guideline for machine resonance frequency [Hz] | 21 | Middle response ↑ | 67.1 | 22 | 75.6 | 23 | 85.2 | 24 | 95.9 | 25 | 108.0 | 26 | 121.7 | 27 | 137.1 | 28 | 154.4 | 29 | 173.9 | 30 | 195.9 | 31 | 220.6 | 32 | 248.5 | 33 | 279.9 | 34 | 315.3 | 35 | 355.1 | 36 | 400.0 | 37 | 446.6 | 38 | 501.2 | 39 | 571.5 | 40 | 642.7 | | ↓ High response | | | |
| Setting value | Machine characteristic | | | | | | | | | | | | | | | | | | | | | | | | | | | | | | | | | | | | | | | | | | | | | | | | | | | | | | | | | | | | | | | | | | | | | | | | | | | | | | | | | | | | | | | | | | | | | | | | | | | | | |
| | Response | Guideline for machine resonance frequency [Hz] | | | | | | | | | | | | | | | | | | | | | | | | | | | | | | | | | | | | | | | | | | | | | | | | | | | | | | | | | | | | | | | | | | | | | | | | | | | | | | | | | | | | | | | | | | | | | | | | | | | | |
| 1 | Low response ↑ | 2.7 | | | | | | | | | | | | | | | | | | | | | | | | | | | | | | | | | | | | | | | | | | | | | | | | | | | | | | | | | | | | | | | | | | | | | | | | | | | | | | | | | | | | | | | | | | | | | | | | | | | | |
| 2 | | 3.6 | | | | | | | | | | | | | | | | | | | | | | | | | | | | | | | | | | | | | | | | | | | | | | | | | | | | | | | | | | | | | | | | | | | | | | | | | | | | | | | | | | | | | | | | | | | | | | | | | | | | |
| 3 | | 4.9 | | | | | | | | | | | | | | | | | | | | | | | | | | | | | | | | | | | | | | | | | | | | | | | | | | | | | | | | | | | | | | | | | | | | | | | | | | | | | | | | | | | | | | | | | | | | | | | | | | | | |
| 4 | | 6.6 | | | | | | | | | | | | | | | | | | | | | | | | | | | | | | | | | | | | | | | | | | | | | | | | | | | | | | | | | | | | | | | | | | | | | | | | | | | | | | | | | | | | | | | | | | | | | | | | | | | | |
| 5 | | 10.0 | | | | | | | | | | | | | | | | | | | | | | | | | | | | | | | | | | | | | | | | | | | | | | | | | | | | | | | | | | | | | | | | | | | | | | | | | | | | | | | | | | | | | | | | | | | | | | | | | | | | |
| 6 | | 11.3 | | | | | | | | | | | | | | | | | | | | | | | | | | | | | | | | | | | | | | | | | | | | | | | | | | | | | | | | | | | | | | | | | | | | | | | | | | | | | | | | | | | | | | | | | | | | | | | | | | | | |
| 7 | | 12.7 | | | | | | | | | | | | | | | | | | | | | | | | | | | | | | | | | | | | | | | | | | | | | | | | | | | | | | | | | | | | | | | | | | | | | | | | | | | | | | | | | | | | | | | | | | | | | | | | | | | | |
| 8 | | 14.3 | | | | | | | | | | | | | | | | | | | | | | | | | | | | | | | | | | | | | | | | | | | | | | | | | | | | | | | | | | | | | | | | | | | | | | | | | | | | | | | | | | | | | | | | | | | | | | | | | | | | |
| 9 | | 16.1 | | | | | | | | | | | | | | | | | | | | | | | | | | | | | | | | | | | | | | | | | | | | | | | | | | | | | | | | | | | | | | | | | | | | | | | | | | | | | | | | | | | | | | | | | | | | | | | | | | | | |
| 10 | | 18.1 | | | | | | | | | | | | | | | | | | | | | | | | | | | | | | | | | | | | | | | | | | | | | | | | | | | | | | | | | | | | | | | | | | | | | | | | | | | | | | | | | | | | | | | | | | | | | | | | | | | | |
| 11 | | 20.4 | | | | | | | | | | | | | | | | | | | | | | | | | | | | | | | | | | | | | | | | | | | | | | | | | | | | | | | | | | | | | | | | | | | | | | | | | | | | | | | | | | | | | | | | | | | | | | | | | | | | |
| 12 | | 23.0 | | | | | | | | | | | | | | | | | | | | | | | | | | | | | | | | | | | | | | | | | | | | | | | | | | | | | | | | | | | | | | | | | | | | | | | | | | | | | | | | | | | | | | | | | | | | | | | | | | | | |
| 13 | | 25.9 | | | | | | | | | | | | | | | | | | | | | | | | | | | | | | | | | | | | | | | | | | | | | | | | | | | | | | | | | | | | | | | | | | | | | | | | | | | | | | | | | | | | | | | | | | | | | | | | | | | | |
| 14 | | 29.2 | | | | | | | | | | | | | | | | | | | | | | | | | | | | | | | | | | | | | | | | | | | | | | | | | | | | | | | | | | | | | | | | | | | | | | | | | | | | | | | | | | | | | | | | | | | | | | | | | | | | |
| 15 | | 32.9 | | | | | | | | | | | | | | | | | | | | | | | | | | | | | | | | | | | | | | | | | | | | | | | | | | | | | | | | | | | | | | | | | | | | | | | | | | | | | | | | | | | | | | | | | | | | | | | | | | | | |
| 16 | | 37.0 | | | | | | | | | | | | | | | | | | | | | | | | | | | | | | | | | | | | | | | | | | | | | | | | | | | | | | | | | | | | | | | | | | | | | | | | | | | | | | | | | | | | | | | | | | | | | | | | | | | | |
| 17 | 41.7 | | | | | | | | | | | | | | | | | | | | | | | | | | | | | | | | | | | | | | | | | | | | | | | | | | | | | | | | | | | | | | | | | | | | | | | | | | | | | | | | | | | | | | | | | | | | | | | | | | | | | |
| 18 | 47.0 | | | | | | | | | | | | | | | | | | | | | | | | | | | | | | | | | | | | | | | | | | | | | | | | | | | | | | | | | | | | | | | | | | | | | | | | | | | | | | | | | | | | | | | | | | | | | | | | | | | | | |
| 19 | 52.9 | | | | | | | | | | | | | | | | | | | | | | | | | | | | | | | | | | | | | | | | | | | | | | | | | | | | | | | | | | | | | | | | | | | | | | | | | | | | | | | | | | | | | | | | | | | | | | | | | | | | | |
| 20 | 59.6 | | | | | | | | | | | | | | | | | | | | | | | | | | | | | | | | | | | | | | | | | | | | | | | | | | | | | | | | | | | | | | | | | | | | | | | | | | | | | | | | | | | | | | | | | | | | | | | | | | | | | |
| | ↓ Middle response | | | | | | | | | | | | | | | | | | | | | | | | | | | | | | | | | | | | | | | | | | | | | | | | | | | | | | | | | | | | | | | | | | | | | | | | | | | | | | | | | | | | | | | | | | | | | | | | | | | | | |
| Setting value | Machine characteristic | | | | | | | | | | | | | | | | | | | | | | | | | | | | | | | | | | | | | | | | | | | | | | | | | | | | | | | | | | | | | | | | | | | | | | | | | | | | | | | | | | | | | | | | | | | | | | | | | | | | | |
| | Response | Guideline for machine resonance frequency [Hz] | | | | | | | | | | | | | | | | | | | | | | | | | | | | | | | | | | | | | | | | | | | | | | | | | | | | | | | | | | | | | | | | | | | | | | | | | | | | | | | | | | | | | | | | | | | | | | | | | | | | |
| 21 | Middle response ↑ | 67.1 | | | | | | | | | | | | | | | | | | | | | | | | | | | | | | | | | | | | | | | | | | | | | | | | | | | | | | | | | | | | | | | | | | | | | | | | | | | | | | | | | | | | | | | | | | | | | | | | | | | | |
| 22 | | 75.6 | | | | | | | | | | | | | | | | | | | | | | | | | | | | | | | | | | | | | | | | | | | | | | | | | | | | | | | | | | | | | | | | | | | | | | | | | | | | | | | | | | | | | | | | | | | | | | | | | | | | |
| 23 | | 85.2 | | | | | | | | | | | | | | | | | | | | | | | | | | | | | | | | | | | | | | | | | | | | | | | | | | | | | | | | | | | | | | | | | | | | | | | | | | | | | | | | | | | | | | | | | | | | | | | | | | | | |
| 24 | | 95.9 | | | | | | | | | | | | | | | | | | | | | | | | | | | | | | | | | | | | | | | | | | | | | | | | | | | | | | | | | | | | | | | | | | | | | | | | | | | | | | | | | | | | | | | | | | | | | | | | | | | | |
| 25 | | 108.0 | | | | | | | | | | | | | | | | | | | | | | | | | | | | | | | | | | | | | | | | | | | | | | | | | | | | | | | | | | | | | | | | | | | | | | | | | | | | | | | | | | | | | | | | | | | | | | | | | | | | |
| 26 | | 121.7 | | | | | | | | | | | | | | | | | | | | | | | | | | | | | | | | | | | | | | | | | | | | | | | | | | | | | | | | | | | | | | | | | | | | | | | | | | | | | | | | | | | | | | | | | | | | | | | | | | | | |
| 27 | | 137.1 | | | | | | | | | | | | | | | | | | | | | | | | | | | | | | | | | | | | | | | | | | | | | | | | | | | | | | | | | | | | | | | | | | | | | | | | | | | | | | | | | | | | | | | | | | | | | | | | | | | | |
| 28 | | 154.4 | | | | | | | | | | | | | | | | | | | | | | | | | | | | | | | | | | | | | | | | | | | | | | | | | | | | | | | | | | | | | | | | | | | | | | | | | | | | | | | | | | | | | | | | | | | | | | | | | | | | |
| 29 | | 173.9 | | | | | | | | | | | | | | | | | | | | | | | | | | | | | | | | | | | | | | | | | | | | | | | | | | | | | | | | | | | | | | | | | | | | | | | | | | | | | | | | | | | | | | | | | | | | | | | | | | | | |
| 30 | | 195.9 | | | | | | | | | | | | | | | | | | | | | | | | | | | | | | | | | | | | | | | | | | | | | | | | | | | | | | | | | | | | | | | | | | | | | | | | | | | | | | | | | | | | | | | | | | | | | | | | | | | | |
| 31 | | 220.6 | | | | | | | | | | | | | | | | | | | | | | | | | | | | | | | | | | | | | | | | | | | | | | | | | | | | | | | | | | | | | | | | | | | | | | | | | | | | | | | | | | | | | | | | | | | | | | | | | | | | |
| 32 | | 248.5 | | | | | | | | | | | | | | | | | | | | | | | | | | | | | | | | | | | | | | | | | | | | | | | | | | | | | | | | | | | | | | | | | | | | | | | | | | | | | | | | | | | | | | | | | | | | | | | | | | | | |
| 33 | | 279.9 | | | | | | | | | | | | | | | | | | | | | | | | | | | | | | | | | | | | | | | | | | | | | | | | | | | | | | | | | | | | | | | | | | | | | | | | | | | | | | | | | | | | | | | | | | | | | | | | | | | | |
| 34 | | 315.3 | | | | | | | | | | | | | | | | | | | | | | | | | | | | | | | | | | | | | | | | | | | | | | | | | | | | | | | | | | | | | | | | | | | | | | | | | | | | | | | | | | | | | | | | | | | | | | | | | | | | |
| 35 | | 355.1 | | | | | | | | | | | | | | | | | | | | | | | | | | | | | | | | | | | | | | | | | | | | | | | | | | | | | | | | | | | | | | | | | | | | | | | | | | | | | | | | | | | | | | | | | | | | | | | | | | | | |
| 36 | | 400.0 | | | | | | | | | | | | | | | | | | | | | | | | | | | | | | | | | | | | | | | | | | | | | | | | | | | | | | | | | | | | | | | | | | | | | | | | | | | | | | | | | | | | | | | | | | | | | | | | | | | | |
| 37 | | 446.6 | | | | | | | | | | | | | | | | | | | | | | | | | | | | | | | | | | | | | | | | | | | | | | | | | | | | | | | | | | | | | | | | | | | | | | | | | | | | | | | | | | | | | | | | | | | | | | | | | | | | |
| 38 | | 501.2 | | | | | | | | | | | | | | | | | | | | | | | | | | | | | | | | | | | | | | | | | | | | | | | | | | | | | | | | | | | | | | | | | | | | | | | | | | | | | | | | | | | | | | | | | | | | | | | | | | | | |
| 39 | | 571.5 | | | | | | | | | | | | | | | | | | | | | | | | | | | | | | | | | | | | | | | | | | | | | | | | | | | | | | | | | | | | | | | | | | | | | | | | | | | | | | | | | | | | | | | | | | | | | | | | | | | | |
| 40 | | 642.7 | | | | | | | | | | | | | | | | | | | | | | | | | | | | | | | | | | | | | | | | | | | | | | | | | | | | | | | | | | | | | | | | | | | | | | | | | | | | | | | | | | | | | | | | | | | | | | | | | | | | |
| | ↓ High response | | | | | | | | | | | | | | | | | | | | | | | | | | | | | | | | | | | | | | | | | | | | | | | | | | | | | | | | | | | | | | | | | | | | | | | | | | | | | | | | | | | | | | | | | | | | | | | | | | | | | |
| Setting range: 1 to 40 | | | | | | | | | | | | | | | | | | | | | | | | | | | | | | | | | | | | | | | | | | | | | | | | | | | | | | | | | | | | | | | | | | | | | | | | | | | | | | | | | | | | | | | | | | | | | | | | | | | | | | |
| PA10 INP In-position range | | Set an in-position range per command pulse. To change the servo motor encoder pulse unit, set [Pr. PC24]. Setting range: 0 to 65535 | 100 [pulse] | <input type="radio"/> | | | | | | | | | | | | | | | | | | | | | | | | | | | | | | | | | | | | | | | | | | | | | | | | | | | | | | | | | | | | | | | | | | | | | | | | | | | | | | | | | | | | | | | | | | | | | | | | | | |

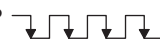
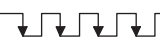
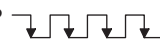
5. PARAMETERS

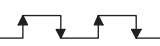
| No./symbol/name | Setting digit | Function | Initial value [unit] | Control mode | | |
|--|---------------|--|----------------------|-----------------------|-----------------------|-----------------------|
| | | | | P | S | T |
| PA11 TLP Forward rotation torque limit | | <p>You can limit the torque generated by the servo motor. Set the parameter referring section 3.6.1 (5).</p> <p>The larger value of [Pr. PA11 Forward rotation torque limit value] or [Pr. PA12 Reverse rotation torque limit value] will be the maximum output voltage (8 V).</p> <p>Set the parameter on the assumption that the maximum torque is 100 [%]. The parameter is for limiting the torque of the servo motor in the CCW power running or CW regeneration. Set this parameter to "0.0" to generate no torque.</p> <p>Setting range: 0.0 to 100.0</p> | 100.0 [%] | <input type="radio"/> | <input type="radio"/> | <input type="radio"/> |
| PA12 TLN Reverse rotation torque limit | | <p>You can limit the torque generated by the servo motor. Set the parameter referring section 3.6.1 (5).</p> <p>The larger value of [Pr. PA11 Forward rotation torque limit value] or [Pr. PA12 Reverse rotation torque limit value] will be the maximum output voltage (8 V).</p> <p>Set the parameter on the assumption that the maximum torque is 100 [%]. The parameter is for limiting the torque of the servo motor in the CW power running or CCW regeneration. Set this parameter to "0.0" to generate no torque.</p> <p>Setting range: 0.0 to 100.0</p> | 100.0 [%] | <input type="radio"/> | <input type="radio"/> | <input type="radio"/> |
| PA13 *PLSS Command pulse input form | ___x | <p>Command input pulse train form selection</p> <p>0: Forward/reverse rotation pulse train</p> <p>1: Signed pulse train</p> <p>2: A-phase/B-phase pulse train</p> <p>Refer to table 5.3 for settings.</p> | 0h | <input type="radio"/> | <input type="radio"/> | <input type="radio"/> |
| | __x_ | <p>Pulse train logic selection</p> <p>0: Positive logic</p> <p>1: Negative logic</p> <p>Refer to table 5.3 for settings.</p> | 0h | <input type="radio"/> | <input type="radio"/> | <input type="radio"/> |
| | _x__ | <p>Command input pulse train filter selection</p> <p>Selecting proper filter enables to enhance noise immunity.</p> <p>0: Command input pulse train is 4 Mpps or less.</p> <p>1: Command input pulse train is 1 Mpps or less.</p> <p>2: Command input pulse train is 500 kpps or less.</p> | 1h | <input type="radio"/> | <input type="radio"/> | <input type="radio"/> |
| | x___ | For manufacturer setting | 0h | <input type="radio"/> | <input type="radio"/> | <input type="radio"/> |

5. PARAMETERS

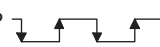
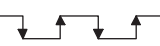
| No./symbol/name | Setting digit | Function | Initial value [unit] | Control mode | | | |
|--|---------------|--|--|--|---|---|--|
| | | | | P | S | T | |
| PA13 *PLSS Command pulse input form | | Table 5.3 Command input pulse train form selection | | | | | |
| | Setting value | Pulse train form | For forward rotation command | For reverse rotation command | | | |
| | 0010h | Forward rotation pulse train Reverse rotation pulse train | PP  NP  | | | | |
| | 0011h | Negative logic | Pulse train + sign | PP  NP  | | | |
| | 0012h | | A-phase pulse train B-phase pulse train | PP  NP  | | | |
| | 0000h | Positive logic | Forward rotation pulse train Reverse rotation pulse train | PP  NP  | | | |
| | 0001h | | Pulse train + sign | PP  NP  | | | |
| | 0002h | A-phase pulse train B-phase pulse train | PP  NP  | | | | |
| Arrows in the table indicate the timing of importing pulse trains. A-phase and B-phase pulse trains are imported after they have been multiplied by 4. | | | | | | | |

5. PARAMETERS

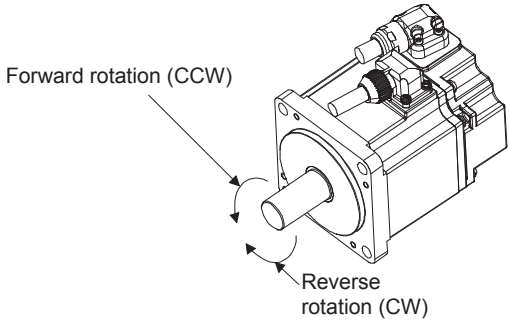
| No./symbol/name | Setting digit | Function | Initial value [unit] | Control mode | | | | | | | | | | | | | |
|--|--------------------------------------|--|----------------------|--------------------------------|-----------------------|--------------------------------------|--------------------------------------|---|-----|----|---|----|-----|---|-----------------------|--|--|
| | | | | P | S | T | | | | | | | | | | | |
| PA14 *POL Rotation direction selection | | <p>Select servo motor rotation direction relative to the input pulse train.</p> <table border="1"> <thead> <tr> <th rowspan="2">Setting value</th> <th colspan="2">Servo motor rotation direction</th> </tr> <tr> <th>When forward rotation pulse is input</th> <th>When reverse rotation pulse is input</th> </tr> </thead> <tbody> <tr> <td>0</td> <td>CCW</td> <td>CW</td> </tr> <tr> <td>1</td> <td>CW</td> <td>CCW</td> </tr> </tbody> </table>  <p>Setting range: 0,1</p> | Setting value | Servo motor rotation direction | | When forward rotation pulse is input | When reverse rotation pulse is input | 0 | CCW | CW | 1 | CW | CCW | 0 | <input type="radio"/> | | |
| Setting value | Servo motor rotation direction | | | | | | | | | | | | | | | | |
| | When forward rotation pulse is input | When reverse rotation pulse is input | | | | | | | | | | | | | | | |
| 0 | CCW | CW | | | | | | | | | | | | | | | |
| 1 | CW | CCW | | | | | | | | | | | | | | | |
| PA15 *ENR Encoder output pulses | | <p>Set the encoder output pulses from the servo amplifier by using the number of output pulses per revolution, dividing ratio, or electronic gear ratio. (after multiplication by 4)</p> <p>To set a numerator of the electronic gear, select "A-axis/B-axis pulse electronic gear setting (_ 3 _)" of "Encoder output pulse setting selection" in [Pr. PC19]. The maximum output frequency is 4.6 Mpps. Set the parameter within this range.</p> <p>Setting range: 1 to 4194304</p> | 4000 [pulse/rev] | <input type="radio"/> | <input type="radio"/> | <input type="radio"/> | | | | | | | | | | | |
| PA16 *ENR2 Encoder output pulses 2 | | <p>Set a denominator of the electronic gear for the A/B-phase pulse output.</p> <p>To set a denominator of the electronic gear, select "A-axis/B-axis pulse electronic gear setting (_ 3 _)" of "Encoder output pulse setting selection" in [Pr. PC19].</p> <p>Setting range: 1 to 4194304</p> | 1 | <input type="radio"/> | <input type="radio"/> | <input type="radio"/> | | | | | | | | | | | |

5. PARAMETERS

| No./symbol/name | Setting digit | Function | Initial value [unit] | Control mode | | | | | | | | | | | | | | | | | | | | | | | | | | | | | | | | | | | | | | | | | | | | | | | | | | | | | | | | | | | | | | | | | | | | | | | | | | | | | | | | | | | | | | | | | | | | | | | | | | | | | | | | | | | | | | | | | | | | | | | | | | | | | | | | | |
|---|--|---|----------------------|--------------|----|----|------|-------------------|----|----|----|----|----|----|------------------|---------|---|---|---|---|---|---|---------|---|---|---|---|---|---|-------|---------|---------|---|---|---|---|---|---------|---------|---|---|---|---|---|-------|---------|---|---|---|---|---|---|---------|---|---|---|---|---|---|-------|---------|---|---|---|---|---|---|---------|---|---|---|---|---|---|-----------------------|---------|---|---|---|---|---|---|---------|---|---|---|---|---|---|-------|---------|---|---|---|---|---|---|---------|---------|---|---|---|---|---|-------|---------|---|---|---|---|---|---|---------|---------|---|---|---|---|---|-------|---------|---|---|---|---|---|---|---------|---------|---|---|---|---|
| | | | | P | S | T | | | | | | | | | | | | | | | | | | | | | | | | | | | | | | | | | | | | | | | | | | | | | | | | | | | | | | | | | | | | | | | | | | | | | | | | | | | | | | | | | | | | | | | | | | | | | | | | | | | | | | | | | | | | | | | | | | | | | | | | | | | | | | | |
| PA19 *BLK Parameter writing inhibit | | Select a reference range and writing range of the parameter. Refer to table 5.4 for settings. | 00AAh | ○ | ○ | ○ | | | | | | | | | | | | | | | | | | | | | | | | | | | | | | | | | | | | | | | | | | | | | | | | | | | | | | | | | | | | | | | | | | | | | | | | | | | | | | | | | | | | | | | | | | | | | | | | | | | | | | | | | | | | | | | | | | | | | | | | | | | | | | | |
| | <p>Table 5.4 [Pr. PA19] setting value and reading/writing range</p> <table border="1"> <thead> <tr> <th>PA19</th> <th>Setting operation</th> <th>PA</th> <th>PB</th> <th>PC</th> <th>PD</th> <th>PE</th> <th>PF</th> </tr> </thead> <tbody> <tr> <td rowspan="2">Other than below</td> <td>Reading</td> <td>○</td> <td>/</td> <td>/</td> <td>/</td> <td>/</td> <td>/</td> </tr> <tr> <td>Writing</td> <td>○</td> <td>/</td> <td>/</td> <td>/</td> <td>/</td> <td>/</td> </tr> <tr> <td rowspan="2">000Ah</td> <td>Reading</td> <td>Only 19</td> <td>/</td> <td>/</td> <td>/</td> <td>/</td> <td>/</td> </tr> <tr> <td>Writing</td> <td>Only 19</td> <td>/</td> <td>/</td> <td>/</td> <td>/</td> <td>/</td> </tr> <tr> <td rowspan="2">000Bh</td> <td>Reading</td> <td>○</td> <td>○</td> <td>○</td> <td>/</td> <td>/</td> <td>/</td> </tr> <tr> <td>Writing</td> <td>○</td> <td>○</td> <td>○</td> <td>/</td> <td>/</td> <td>/</td> </tr> <tr> <td rowspan="2">000Ch</td> <td>Reading</td> <td>○</td> <td>○</td> <td>○</td> <td>○</td> <td>/</td> <td>/</td> </tr> <tr> <td>Writing</td> <td>○</td> <td>○</td> <td>○</td> <td>○</td> <td>/</td> <td>/</td> </tr> <tr> <td rowspan="2">00AAh (initial value)</td> <td>Reading</td> <td>○</td> <td>○</td> <td>○</td> <td>○</td> <td>○</td> <td>○</td> </tr> <tr> <td>Writing</td> <td>○</td> <td>○</td> <td>○</td> <td>○</td> <td>○</td> <td>○</td> </tr> <tr> <td rowspan="2">100Bh</td> <td>Reading</td> <td>○</td> <td>/</td> <td>/</td> <td>/</td> <td>/</td> <td>/</td> </tr> <tr> <td>Writing</td> <td>Only 19</td> <td>/</td> <td>/</td> <td>/</td> <td>/</td> <td>/</td> </tr> <tr> <td rowspan="2">100Ch</td> <td>Reading</td> <td>○</td> <td>○</td> <td>○</td> <td>○</td> <td>/</td> <td>/</td> </tr> <tr> <td>Writing</td> <td>Only 19</td> <td>/</td> <td>/</td> <td>/</td> <td>/</td> <td>/</td> </tr> <tr> <td rowspan="2">10AAh</td> <td>Reading</td> <td>○</td> <td>○</td> <td>○</td> <td>○</td> <td>○</td> <td>○</td> </tr> <tr> <td>Writing</td> <td>Only 19</td> <td>/</td> <td>/</td> <td>/</td> <td>/</td> <td>/</td> </tr> </tbody> </table> | | | | | | PA19 | Setting operation | PA | PB | PC | PD | PE | PF | Other than below | Reading | ○ | / | / | / | / | / | Writing | ○ | / | / | / | / | / | 000Ah | Reading | Only 19 | / | / | / | / | / | Writing | Only 19 | / | / | / | / | / | 000Bh | Reading | ○ | ○ | ○ | / | / | / | Writing | ○ | ○ | ○ | / | / | / | 000Ch | Reading | ○ | ○ | ○ | ○ | / | / | Writing | ○ | ○ | ○ | ○ | / | / | 00AAh (initial value) | Reading | ○ | ○ | ○ | ○ | ○ | ○ | Writing | ○ | ○ | ○ | ○ | ○ | ○ | 100Bh | Reading | ○ | / | / | / | / | / | Writing | Only 19 | / | / | / | / | / | 100Ch | Reading | ○ | ○ | ○ | ○ | / | / | Writing | Only 19 | / | / | / | / | / | 10AAh | Reading | ○ | ○ | ○ | ○ | ○ | ○ | Writing | Only 19 | / | / | / | / |
| PA19 | Setting operation | PA | PB | PC | PD | PE | PF | | | | | | | | | | | | | | | | | | | | | | | | | | | | | | | | | | | | | | | | | | | | | | | | | | | | | | | | | | | | | | | | | | | | | | | | | | | | | | | | | | | | | | | | | | | | | | | | | | | | | | | | | | | | | | | | | | | | | | | | | | | | | | |
| Other than below | Reading | ○ | / | / | / | / | / | | | | | | | | | | | | | | | | | | | | | | | | | | | | | | | | | | | | | | | | | | | | | | | | | | | | | | | | | | | | | | | | | | | | | | | | | | | | | | | | | | | | | | | | | | | | | | | | | | | | | | | | | | | | | | | | | | | | | | | | | | | | | | |
| | Writing | ○ | / | / | / | / | / | | | | | | | | | | | | | | | | | | | | | | | | | | | | | | | | | | | | | | | | | | | | | | | | | | | | | | | | | | | | | | | | | | | | | | | | | | | | | | | | | | | | | | | | | | | | | | | | | | | | | | | | | | | | | | | | | | | | | | | | | | | | | | |
| 000Ah | Reading | Only 19 | / | / | / | / | / | | | | | | | | | | | | | | | | | | | | | | | | | | | | | | | | | | | | | | | | | | | | | | | | | | | | | | | | | | | | | | | | | | | | | | | | | | | | | | | | | | | | | | | | | | | | | | | | | | | | | | | | | | | | | | | | | | | | | | | | | | | | | | |
| | Writing | Only 19 | / | / | / | / | / | | | | | | | | | | | | | | | | | | | | | | | | | | | | | | | | | | | | | | | | | | | | | | | | | | | | | | | | | | | | | | | | | | | | | | | | | | | | | | | | | | | | | | | | | | | | | | | | | | | | | | | | | | | | | | | | | | | | | | | | | | | | | | |
| 000Bh | Reading | ○ | ○ | ○ | / | / | / | | | | | | | | | | | | | | | | | | | | | | | | | | | | | | | | | | | | | | | | | | | | | | | | | | | | | | | | | | | | | | | | | | | | | | | | | | | | | | | | | | | | | | | | | | | | | | | | | | | | | | | | | | | | | | | | | | | | | | | | | | | | | | |
| | Writing | ○ | ○ | ○ | / | / | / | | | | | | | | | | | | | | | | | | | | | | | | | | | | | | | | | | | | | | | | | | | | | | | | | | | | | | | | | | | | | | | | | | | | | | | | | | | | | | | | | | | | | | | | | | | | | | | | | | | | | | | | | | | | | | | | | | | | | | | | | | | | | | |
| 000Ch | Reading | ○ | ○ | ○ | ○ | / | / | | | | | | | | | | | | | | | | | | | | | | | | | | | | | | | | | | | | | | | | | | | | | | | | | | | | | | | | | | | | | | | | | | | | | | | | | | | | | | | | | | | | | | | | | | | | | | | | | | | | | | | | | | | | | | | | | | | | | | | | | | | | | | |
| | Writing | ○ | ○ | ○ | ○ | / | / | | | | | | | | | | | | | | | | | | | | | | | | | | | | | | | | | | | | | | | | | | | | | | | | | | | | | | | | | | | | | | | | | | | | | | | | | | | | | | | | | | | | | | | | | | | | | | | | | | | | | | | | | | | | | | | | | | | | | | | | | | | | | | |
| 00AAh (initial value) | Reading | ○ | ○ | ○ | ○ | ○ | ○ | | | | | | | | | | | | | | | | | | | | | | | | | | | | | | | | | | | | | | | | | | | | | | | | | | | | | | | | | | | | | | | | | | | | | | | | | | | | | | | | | | | | | | | | | | | | | | | | | | | | | | | | | | | | | | | | | | | | | | | | | | | | | | |
| | Writing | ○ | ○ | ○ | ○ | ○ | ○ | | | | | | | | | | | | | | | | | | | | | | | | | | | | | | | | | | | | | | | | | | | | | | | | | | | | | | | | | | | | | | | | | | | | | | | | | | | | | | | | | | | | | | | | | | | | | | | | | | | | | | | | | | | | | | | | | | | | | | | | | | | | | | |
| 100Bh | Reading | ○ | / | / | / | / | / | | | | | | | | | | | | | | | | | | | | | | | | | | | | | | | | | | | | | | | | | | | | | | | | | | | | | | | | | | | | | | | | | | | | | | | | | | | | | | | | | | | | | | | | | | | | | | | | | | | | | | | | | | | | | | | | | | | | | | | | | | | | | | |
| | Writing | Only 19 | / | / | / | / | / | | | | | | | | | | | | | | | | | | | | | | | | | | | | | | | | | | | | | | | | | | | | | | | | | | | | | | | | | | | | | | | | | | | | | | | | | | | | | | | | | | | | | | | | | | | | | | | | | | | | | | | | | | | | | | | | | | | | | | | | | | | | | | |
| 100Ch | Reading | ○ | ○ | ○ | ○ | / | / | | | | | | | | | | | | | | | | | | | | | | | | | | | | | | | | | | | | | | | | | | | | | | | | | | | | | | | | | | | | | | | | | | | | | | | | | | | | | | | | | | | | | | | | | | | | | | | | | | | | | | | | | | | | | | | | | | | | | | | | | | | | | | |
| | Writing | Only 19 | / | / | / | / | / | | | | | | | | | | | | | | | | | | | | | | | | | | | | | | | | | | | | | | | | | | | | | | | | | | | | | | | | | | | | | | | | | | | | | | | | | | | | | | | | | | | | | | | | | | | | | | | | | | | | | | | | | | | | | | | | | | | | | | | | | | | | | | |
| 10AAh | Reading | ○ | ○ | ○ | ○ | ○ | ○ | | | | | | | | | | | | | | | | | | | | | | | | | | | | | | | | | | | | | | | | | | | | | | | | | | | | | | | | | | | | | | | | | | | | | | | | | | | | | | | | | | | | | | | | | | | | | | | | | | | | | | | | | | | | | | | | | | | | | | | | | | | | | | |
| | Writing | Only 19 | / | / | / | / | / | | | | | | | | | | | | | | | | | | | | | | | | | | | | | | | | | | | | | | | | | | | | | | | | | | | | | | | | | | | | | | | | | | | | | | | | | | | | | | | | | | | | | | | | | | | | | | | | | | | | | | | | | | | | | | | | | | | | | | | | | | | | | | |
| PA20 *TDS Tough drive setting | | Alarms may not be avoided with the tough drive function depending on the situations of the power supply and load fluctuation. You can assign MTTR (During tough drive) to pins CN1-22 to CN1-25 and CN1-49 with [Pr. PD23] to [Pr. PD26] and [Pr. PD28]. | | | | | | | | | | | | | | | | | | | | | | | | | | | | | | | | | | | | | | | | | | | | | | | | | | | | | | | | | | | | | | | | | | | | | | | | | | | | | | | | | | | | | | | | | | | | | | | | | | | | | | | | | | | | | | | | | | | | | | | | | | | | | | | | | | | |
| | ___x | For manufacturer setting | 0h | / | / | / | | | | | | | | | | | | | | | | | | | | | | | | | | | | | | | | | | | | | | | | | | | | | | | | | | | | | | | | | | | | | | | | | | | | | | | | | | | | | | | | | | | | | | | | | | | | | | | | | | | | | | | | | | | | | | | | | | | | | | | | | | | | | | | |
| | __x_ | Vibration tough drive selection 0: Disabled 1: Enabled Selecting "1" enables to suppress vibrations by automatically changing setting values of [Pr. PB13 Machine resonance suppression filter 1] and [Pr. PB15 Machine resonance suppression filter 2] in case that the vibration exceed the value of the oscillation level set in [Pr. PF23]. To output the oscillation detection alarm as a warning, set [Pr. PF24 Vibration tough drive function selection]. Refer to section 7.3 for details. | 0h | ○ | ○ | / | | | | | | | | | | | | | | | | | | | | | | | | | | | | | | | | | | | | | | | | | | | | | | | | | | | | | | | | | | | | | | | | | | | | | | | | | | | | | | | | | | | | | | | | | | | | | | | | | | | | | | | | | | | | | | | | | | | | | | | | | | | | | | | |
| | _x__ | Instantaneous power failure tough drive selection 0: Disabled 1: Enabled Selecting "1" enables to avoid generating [AL. 10 Undervoltage] using the electrical energy charged in the capacitor in case that an instantaneous power failure occurs during operation. Set the time of until [AL. 10 Undervoltage] occurs in [Pr. PF25 Instantaneous power failure tough drive - Detection time]. | 0h | ○ | ○ | ○ | | | | | | | | | | | | | | | | | | | | | | | | | | | | | | | | | | | | | | | | | | | | | | | | | | | | | | | | | | | | | | | | | | | | | | | | | | | | | | | | | | | | | | | | | | | | | | | | | | | | | | | | | | | | | | | | | | | | | | | | | | | | | | | |
| x___ | For manufacturer setting | 0h | / | / | / | | | | | | | | | | | | | | | | | | | | | | | | | | | | | | | | | | | | | | | | | | | | | | | | | | | | | | | | | | | | | | | | | | | | | | | | | | | | | | | | | | | | | | | | | | | | | | | | | | | | | | | | | | | | | | | | | | | | | | | | | | | | | | | | |

5. PARAMETERS

| No./symbol/name | Setting digit | Function | Initial value [unit] | Control mode | | |
|--|---|---|----------------------|--------------------------|--------------------------|--------------------------|
| | | | | P | S | T |
| PA21 *AOP3 Function selection A-3 | ___x | One-touch tuning function selection 0: Disabled 1: Enabled When the digit is "0", the one-touch tuning is not available. | 1h | <input type="radio"/> | <input type="radio"/> | <input type="radio"/> |
| | __x_ | For manufacturer setting | 0h | <input type="checkbox"/> | <input type="checkbox"/> | <input type="checkbox"/> |
| | _x__ | | 0h | <input type="checkbox"/> | <input type="checkbox"/> | <input type="checkbox"/> |
| | x___ | Electronic gear selection 0: Electronic gear ([Pr. PA06] and [Pr. PA07]) 1: Number of command input pulses per revolution ([Pr. PA05]) 2: J3A electronic gear setting value compatibility mode (Electronic gear ([Pr. PA06] and [Pr. PA07] × 16)) Setting the parameter enables the electronic gear value set in MR-J3-A. | 0h | <input type="radio"/> | <input type="radio"/> | <input type="radio"/> |
| PA23 DRAT Drive recorder arbitrary alarm trigger setting | __xx | Alarm detail No. setting Set the digits when you execute the trigger with arbitrary alarm detail No. for the drive recorder function. When these digits are "0 0", only the arbitrary alarm No. setting will be enabled. | 00h | <input type="radio"/> | <input type="radio"/> | <input type="radio"/> |
| | xx__ | Alarm No. setting Set the digits when you execute the trigger with arbitrary alarm No. for the drive recorder function. When "0 0" are set, arbitrary alarm trigger of the drive recorder will be disabled. | 00h | <input type="radio"/> | <input type="radio"/> | <input type="radio"/> |
| | Setting example: To activate the drive recorder when [AL. 50 Overload 1] occurs, set "5 0 0 0". To activate the drive recorder when [AL. 50.3 Thermal overload error 4 during operation] occurs, set "5 0 0 3". | | | | | |
| PA24 AOP4 Function selection A-4 | ___x | Vibration suppression mode selection 0: Standard mode 1: 3 inertia mode 2: Low response mode When you select the standard mode or low response mode, "Vibration suppression control 2" is not available. When you select the 3 inertia mode, the feed forward gain is not available. Before changing the control mode during the 3 inertia mode or low response mode, stop the motor. | 0h | <input type="radio"/> | <input type="radio"/> | <input type="radio"/> |
| | __x_ | For manufacturer setting | 0h | <input type="checkbox"/> | <input type="checkbox"/> | <input type="checkbox"/> |
| | _x__ | | 0h | <input type="checkbox"/> | <input type="checkbox"/> | <input type="checkbox"/> |
| | x___ | | 0h | <input type="checkbox"/> | <input type="checkbox"/> | <input type="checkbox"/> |

5.2.2 Gain/filter setting parameters ([Pr. PB__])

| No./symbol/name | Setting digit | Function | Initial value [unit] | Control mode | | |
|---|---------------|--|----------------------|--------------------------|--------------------------|--------------------------|
| | | | | P | S | T |
| PB01 FILT Adaptive tuning mode (adaptive filter II) | ___x | Filter tuning mode selection Set the adaptive filter tuning. Select the adjustment mode of the machine resonance suppression filter 1. Refer to section 7.1.2 for details. 0: Disabled 1: Automatic setting (Do not use this in the torque control mode.) 2: Manual setting | 0h | <input type="radio"/> | <input type="radio"/> | <input type="radio"/> |
| | __x_ | For manufacturer setting | 0h | <input type="checkbox"/> | <input type="checkbox"/> | <input type="checkbox"/> |
| | _x__ | | 0h | <input type="checkbox"/> | <input type="checkbox"/> | <input type="checkbox"/> |
| | x___ | | 0h | <input type="checkbox"/> | <input type="checkbox"/> | <input type="checkbox"/> |

5. PARAMETERS

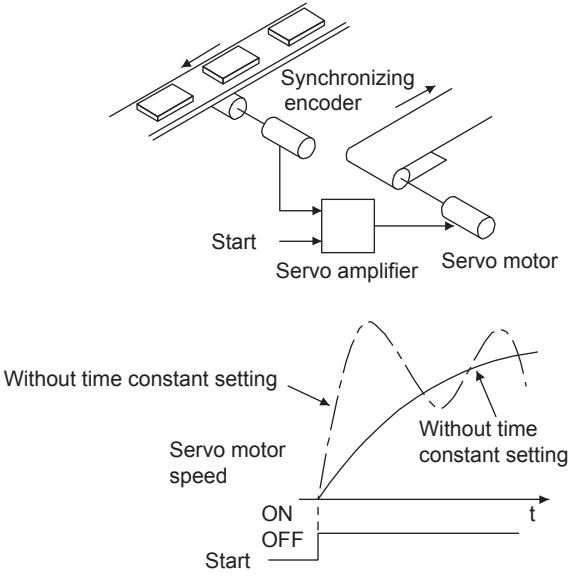
| No./symbol/name | Setting digit | Function | Initial value [unit] | Control mode | | |
|---|---------------|---|----------------------|--------------|---|---|
| | | | | P | S | T |
| PB02 VRFT Vibration suppression control tuning mode (advanced vibration suppression control II) | ___x | Vibration suppression control 1 tuning mode selection Select the tuning mode of the vibration suppression control 1. Refer to section 7.1.5 for details. 0: Disabled 1: Automatic setting 2: Manual setting | 0h | ○ | | |
| | __x_ | Vibration suppression control 2 tuning mode selection Select the tuning mode of the vibration suppression control 2. To enable the digit, select "3 inertia mode (___1)" of "Vibration suppression mode selection" in [Pr. PA24]. Refer to section 7.1.5 for details. 0: Disabled 1: Automatic setting 2: Manual setting | 0h | ○ | | |
| | _x__ | For manufacturer setting | 0h | | | |
| | x___ | | 0h | | | |
| PB03 PST Position command acceleration/deceleration time constant (position smoothing) | | <p>This is used to set the constant of a primary delay to the position command. You can select a control method from "Primary delay" or "Linear acceleration/deceleration" in [Pr. PB25 Function selection B-1]. The setting range of "Linear acceleration/deceleration" is 0 ms to 10 ms. Setting of longer than 10 ms will be recognized as 10 ms.</p> <p>When the linear acceleration/deceleration is selected, do not change the "Control mode selection" ([Pr. PA01]). Doing so will cause the servo motor to make a sudden stop at the time of position control mode switching or restart.</p> <p>(Example) When a command is given from a synchronizing encoder, synchronous operation will start smoothly even if it start during line operation.</p>  <p>Setting range: 0 to 65535</p> | 0 [ms] | ○ | | |
| PB04 FFC Feed forward gain | | <p>Set the feed forward gain. When the setting is 100%, the droop pulses during operation at constant speed are nearly zero. However, sudden acceleration/deceleration will increase the overshoot. As a guideline, when the feed forward gain setting is 100%, set 1 s or more as the acceleration time constant up to the rated speed.</p> <p>Setting range: 0 to 100</p> | 0 [%] | ○ | | |

5. PARAMETERS

| No./symbol/name | Setting digit | Function | Initial value [unit] | Control mode | | | | | | |
|---|-------------------|--|-------------------------|-----------------------|-----------------------|---|---------|----------------|---|-------------------|
| | | | | P | S | T | | | | |
| PB06 GD2 Load to motor inertia ratio | | <p>This is used to set the load to motor inertia ratio.</p> <p>The setting of the parameter will be the automatic setting or manual setting depending on the [Pr. PA08] setting. Refer to the following table for details.</p> <p>When the parameter is automatic setting, the value will vary between 0.00 and 100.00.</p> <p>Setting range: 0.00 to 300.00</p> | 7.00 Multiplier (×1) | <input type="radio"/> | <input type="radio"/> | | | | | |
| | | <table border="1"> <thead> <tr> <th>Pr.PA08</th> <th>This parameter</th> </tr> </thead> <tbody> <tr> <td>___ 0 (2 gain adjustment mode 1 (interpolation mode))</td> <td rowspan="2">Automatic setting</td> </tr> <tr> <td>___ 1: (Auto tuning mode 1)</td> </tr> <tr> <td>___ 2: (Auto tuning mode 2)</td> <td rowspan="3">Manual setting</td> </tr> <tr> <td>___ 3 (Manual mode)</td> </tr> <tr> <td>___ 4: (2 gain adjustment mode 2)</td> </tr> </tbody> </table> | | | | | Pr.PA08 | This parameter | ___ 0 (2 gain adjustment mode 1 (interpolation mode)) | Automatic setting |
| Pr.PA08 | This parameter | | | | | | | | | |
| ___ 0 (2 gain adjustment mode 1 (interpolation mode)) | Automatic setting | | | | | | | | | |
| ___ 1: (Auto tuning mode 1) | | | | | | | | | | |
| ___ 2: (Auto tuning mode 2) | Manual setting | | | | | | | | | |
| ___ 3 (Manual mode) | | | | | | | | | | |
| ___ 4: (2 gain adjustment mode 2) | | | | | | | | | | |
| PB07 PG1 Model loop gain | | <p>Set the response gain up to the target position.</p> <p>Increasing the setting value will also increase the response level to the position command but will be liable to generate vibration and/or noise.</p> <p>The setting of the parameter will be the automatic setting or manual setting depending on the [Pr. PA08] setting. Refer to the following table for details.</p> <p>Setting range: 1.0 to 2000.0</p> | 15.0 [rad/s] | <input type="radio"/> | <input type="radio"/> | | | | | |
| | | <table border="1"> <thead> <tr> <th>Pr.PA08</th> <th>This parameter</th> </tr> </thead> <tbody> <tr> <td>___ 0 (2 gain adjustment mode 1 (interpolation mode))</td> <td>Manual setting</td> </tr> <tr> <td>___ 1: (Auto tuning mode 1)</td> <td rowspan="2">Automatic setting</td> </tr> <tr> <td>___ 2: (Auto tuning mode 2)</td> </tr> <tr> <td>___ 3 (Manual mode)</td> <td rowspan="2">Manual setting</td> </tr> <tr> <td>___ 4: (2 gain adjustment mode 2)</td> </tr> </tbody> </table> | | | | | Pr.PA08 | This parameter | ___ 0 (2 gain adjustment mode 1 (interpolation mode)) | Manual setting |
| Pr.PA08 | This parameter | | | | | | | | | |
| ___ 0 (2 gain adjustment mode 1 (interpolation mode)) | Manual setting | | | | | | | | | |
| ___ 1: (Auto tuning mode 1) | Automatic setting | | | | | | | | | |
| ___ 2: (Auto tuning mode 2) | | | | | | | | | | |
| ___ 3 (Manual mode) | Manual setting | | | | | | | | | |
| ___ 4: (2 gain adjustment mode 2) | | | | | | | | | | |
| PB08 PG2 Position loop gain | | <p>This is used to set the gain of the position loop.</p> <p>Set this parameter to increase the position response to level load disturbance.</p> <p>Increasing the setting value will also increase the response level to the load disturbance but will be liable to generate vibration and/or noise.</p> <p>The setting of the parameter will be the automatic setting or manual setting depending on the [Pr. PA08] setting. Refer to the following table for details.</p> <p>Setting range: 1.0 to 2000.0</p> | 37.0 [rad/s] | <input type="radio"/> | | | | | | |
| | | <table border="1"> <thead> <tr> <th>Pr.PA08</th> <th>This parameter</th> </tr> </thead> <tbody> <tr> <td>___ 0 (2 gain adjustment mode 1 (interpolation mode))</td> <td rowspan="3">Automatic setting</td> </tr> <tr> <td>___ 1: (Auto tuning mode 1)</td> </tr> <tr> <td>___ 2: (Auto tuning mode 2)</td> </tr> <tr> <td>___ 3 (Manual mode)</td> <td rowspan="2">Manual setting</td> </tr> <tr> <td>___ 4: (2 gain adjustment mode 2)</td> </tr> </tbody> </table> | | | | | Pr.PA08 | This parameter | ___ 0 (2 gain adjustment mode 1 (interpolation mode)) | Automatic setting |
| Pr.PA08 | This parameter | | | | | | | | | |
| ___ 0 (2 gain adjustment mode 1 (interpolation mode)) | Automatic setting | | | | | | | | | |
| ___ 1: (Auto tuning mode 1) | | | | | | | | | | |
| ___ 2: (Auto tuning mode 2) | | | | | | | | | | |
| ___ 3 (Manual mode) | Manual setting | | | | | | | | | |
| ___ 4: (2 gain adjustment mode 2) | | | | | | | | | | |
| PB09 VG2 Speed loop gain | | <p>This is used to set the gain of the speed loop.</p> <p>Set this parameter when vibration occurs on machines of low rigidity or large backlash. Increasing the setting value will also increase the response level but will be liable to generate vibration and/or noise.</p> <p>The setting of the parameter will be the automatic setting or manual setting depending on the [Pr. PA08] setting. Refer to the table of [Pr. PB08] for details.</p> <p>Setting range: 20 to 65535</p> | 823 [rad/s] | <input type="radio"/> | <input type="radio"/> | | | | | |
| | | | | | | | | | | |

5. PARAMETERS

| No./symbol/name | Setting digit | Function | Initial value [unit] | Control mode | | |
|---|---------------|--|----------------------|-----------------------|-----------------------|-----------------------|
| | | | | P | S | T |
| PB10 VIC Speed integral compensation | | This is used to set the integral time constant of the speed loop. Decreasing the setting value will increase the response level but will be liable to generate vibration and/or noise. The setting of the parameter will be the automatic setting or manual setting depending on the [Pr. PA08] setting. Refer to the table of [Pr. PB08] for details. Setting range: 0.1 to 1000.0 | 33.7 [ms] | <input type="radio"/> | <input type="radio"/> | <input type="radio"/> |
| PB11 VDC Speed differential compensation | | This is used to set the differential compensation. To enable the setting value, turn on PC (proportional control). Setting range: 0 to 1000 | 980 | <input type="radio"/> | <input type="radio"/> | <input type="radio"/> |
| PB12 OVA Overshoot amount compensation | | Set a viscous friction torque per percent to the servo motor rated speed. When the response level is low, or when the torque is limited, the efficiency of the parameter may be lower. Setting range: 0 to 100 | 0 [%] | <input type="radio"/> | <input type="radio"/> | <input type="radio"/> |
| PB13 NH1 Machine resonance suppression filter 1 | | Machine resonance suppression filter 1 Set the notch frequency of the machine resonance suppression filter 1. When you select "Automatic setting (_ _ _ 1)" of "Filter tuning mode selection" in [Pr. PB01], this parameter will be adjusted automatically. When you select "Manual setting (_ _ _ 2)" of "Filter tuning mode selection" in [Pr. PB01], the setting value will be enabled. Setting range: 10 to 4500 | 4500 [Hz] | <input type="radio"/> | <input type="radio"/> | <input type="radio"/> |
| PB14 NHQ1 Notch shape selection 1 | | Set the shape of the machine resonance suppression filter 1. When you select "Automatic setting (_ _ _ 1)" of "Filter tuning mode selection" in [Pr. PB01], this parameter will be adjusted automatically. Set manually for the manual setting. | | | | |
| | _ _ _ x | For manufacturer setting | 0h | <input type="radio"/> | <input type="radio"/> | <input type="radio"/> |
| | _ _ x _ | Notch depth selection 0: -40 dB 1: -14 dB 2: -8 dB 3: -4 dB | 0h | <input type="radio"/> | <input type="radio"/> | <input type="radio"/> |
| | _ x _ _ | Notch width selection 0: $\alpha = 2$ 1: $\alpha = 3$ 2: $\alpha = 4$ 3: $\alpha = 5$ | 0h | <input type="radio"/> | <input type="radio"/> | <input type="radio"/> |
| | x _ _ _ | For manufacturer setting | 0h | <input type="radio"/> | <input type="radio"/> | <input type="radio"/> |
| PB15 NH2 Machine resonance suppression filter 2 | | Set the notch frequency of the machine resonance suppression filter 2. To enable the setting value, select "Enabled (_ _ _ 1)" of "Machine resonance suppression filter 2 selection" in [Pr. PB16]. Setting range: 10 to 4500 | 4500 [Hz] | <input type="radio"/> | <input type="radio"/> | <input type="radio"/> |

5. PARAMETERS

| No./symbol/name | Setting digit | Function | Initial value [unit] | Control mode | | | | | | | | | | | | | | | | | | | | | | | | | | | | | | | | | | | | | | | | | | | | | | | | | | | | | | | | | | | | | | | | | | | | | | |
|---|---|--|--------------------------|--------------------------|--------------------------|--------------------------|---------------|----------------|---------------|----------------|----|----------|----|-----|----|----------|----|-----|----|------|----|-----|----|------|----|-----|----|------|----|-----|----|------|----|-----|----|------|----|-----|----|------|----|-----|----|------|----|-----|----|------|----|-----|----|-----|----|-----|----|-----|----|-----|----|-----|----|-----|----|-----|----|-----|----|-----|----|-----|----|-----|----|-----|
| | | | | P | S | T | | | | | | | | | | | | | | | | | | | | | | | | | | | | | | | | | | | | | | | | | | | | | | | | | | | | | | | | | | | | | | | | | | | | |
| PB16 NHQ2 Notch shape selection 2 | Set the shape of the machine resonance suppression filter 2. | | | | | | | | | | | | | | | | | | | | | | | | | | | | | | | | | | | | | | | | | | | | | | | | | | | | | | | | | | | | | | | | | | | | | | | | | |
| | ___x | Machine resonance suppression filter 2 selection 0: Disabled 1: Enabled | 0h | <input type="radio"/> | <input type="radio"/> | <input type="radio"/> | | | | | | | | | | | | | | | | | | | | | | | | | | | | | | | | | | | | | | | | | | | | | | | | | | | | | | | | | | | | | | | | | | | | |
| | __x_ | Notch depth selection 0: -40 dB 1: -14 dB 2: -8 dB 3: -4 dB | 0h | <input type="radio"/> | <input type="radio"/> | <input type="radio"/> | | | | | | | | | | | | | | | | | | | | | | | | | | | | | | | | | | | | | | | | | | | | | | | | | | | | | | | | | | | | | | | | | | | | |
| | _x__ | Notch width selection 0: $\alpha = 2$ 1: $\alpha = 3$ 2: $\alpha = 4$ 3: $\alpha = 5$ | 0h | <input type="radio"/> | <input type="radio"/> | <input type="radio"/> | | | | | | | | | | | | | | | | | | | | | | | | | | | | | | | | | | | | | | | | | | | | | | | | | | | | | | | | | | | | | | | | | | | | |
| x___ | For manufacturer setting | 0h | <input type="checkbox"/> | <input type="checkbox"/> | <input type="checkbox"/> | | | | | | | | | | | | | | | | | | | | | | | | | | | | | | | | | | | | | | | | | | | | | | | | | | | | | | | | | | | | | | | | | | | | | |
| PB17 NHF Shaft resonance suppression filter | Set the shaft resonance suppression filter. This is used to suppress a low-frequency machine vibration. When you select "Automatic setting (___0)" of "Shaft resonance suppression filter selection" in [Pr. PB23], the value will be calculated automatically from the servo motor you use and load to motor inertia ratio. Set manually for "Manual setting (___1)". When "Shaft resonance suppression filter selection" is "Disabled (___2)" in [Pr. PB23], the setting value of this parameter will be disabled. When you select "Enabled (___1)" of "Machine resonance suppression filter 4 selection" in [Pr. PB49], the shaft resonance suppression filter is not available. | | | | | | | | | | | | | | | | | | | | | | | | | | | | | | | | | | | | | | | | | | | | | | | | | | | | | | | | | | | | | | | | | | | | | | | | | |
| | __xx | Shaft resonance suppression filter setting frequency selection Refer to table 5.5 for settings. Set the value closest to the frequency you need. | 00h | <input type="radio"/> | <input type="radio"/> | <input type="radio"/> | | | | | | | | | | | | | | | | | | | | | | | | | | | | | | | | | | | | | | | | | | | | | | | | | | | | | | | | | | | | | | | | | | | | |
| | _x__ | Notch depth selection 0: -40 dB 1: -14 dB 2: -8 dB 3: -4 dB | 0h | <input type="radio"/> | <input type="radio"/> | <input type="radio"/> | | | | | | | | | | | | | | | | | | | | | | | | | | | | | | | | | | | | | | | | | | | | | | | | | | | | | | | | | | | | | | | | | | | | |
| | x___ | For manufacturer setting | 0h | <input type="checkbox"/> | <input type="checkbox"/> | <input type="checkbox"/> | | | | | | | | | | | | | | | | | | | | | | | | | | | | | | | | | | | | | | | | | | | | | | | | | | | | | | | | | | | | | | | | | | | | |
| <p style="text-align: center;">Table 5.5 Shaft resonance suppression filter setting frequency selection</p> <table border="1" style="margin-left: auto; margin-right: auto;"> <thead> <tr> <th>Setting value</th> <th>Frequency [Hz]</th> <th>Setting value</th> <th>Frequency [Hz]</th> </tr> </thead> <tbody> <tr><td>00</td><td>Disabled</td><td>10</td><td>562</td></tr> <tr><td>01</td><td>Disabled</td><td>11</td><td>529</td></tr> <tr><td>02</td><td>4500</td><td>12</td><td>500</td></tr> <tr><td>03</td><td>3000</td><td>13</td><td>473</td></tr> <tr><td>04</td><td>2250</td><td>14</td><td>450</td></tr> <tr><td>05</td><td>1800</td><td>15</td><td>428</td></tr> <tr><td>06</td><td>1500</td><td>16</td><td>409</td></tr> <tr><td>07</td><td>1285</td><td>17</td><td>391</td></tr> <tr><td>08</td><td>1125</td><td>18</td><td>375</td></tr> <tr><td>09</td><td>1000</td><td>19</td><td>360</td></tr> <tr><td>0A</td><td>900</td><td>1A</td><td>346</td></tr> <tr><td>0B</td><td>818</td><td>1B</td><td>333</td></tr> <tr><td>0C</td><td>750</td><td>1C</td><td>321</td></tr> <tr><td>0D</td><td>692</td><td>1D</td><td>310</td></tr> <tr><td>0E</td><td>642</td><td>1E</td><td>300</td></tr> <tr><td>0F</td><td>600</td><td>1F</td><td>290</td></tr> </tbody> </table> | | | | | | | Setting value | Frequency [Hz] | Setting value | Frequency [Hz] | 00 | Disabled | 10 | 562 | 01 | Disabled | 11 | 529 | 02 | 4500 | 12 | 500 | 03 | 3000 | 13 | 473 | 04 | 2250 | 14 | 450 | 05 | 1800 | 15 | 428 | 06 | 1500 | 16 | 409 | 07 | 1285 | 17 | 391 | 08 | 1125 | 18 | 375 | 09 | 1000 | 19 | 360 | 0A | 900 | 1A | 346 | 0B | 818 | 1B | 333 | 0C | 750 | 1C | 321 | 0D | 692 | 1D | 310 | 0E | 642 | 1E | 300 | 0F | 600 | 1F | 290 |
| Setting value | Frequency [Hz] | Setting value | Frequency [Hz] | | | | | | | | | | | | | | | | | | | | | | | | | | | | | | | | | | | | | | | | | | | | | | | | | | | | | | | | | | | | | | | | | | | | | | | |
| 00 | Disabled | 10 | 562 | | | | | | | | | | | | | | | | | | | | | | | | | | | | | | | | | | | | | | | | | | | | | | | | | | | | | | | | | | | | | | | | | | | | | | | |
| 01 | Disabled | 11 | 529 | | | | | | | | | | | | | | | | | | | | | | | | | | | | | | | | | | | | | | | | | | | | | | | | | | | | | | | | | | | | | | | | | | | | | | | |
| 02 | 4500 | 12 | 500 | | | | | | | | | | | | | | | | | | | | | | | | | | | | | | | | | | | | | | | | | | | | | | | | | | | | | | | | | | | | | | | | | | | | | | | |
| 03 | 3000 | 13 | 473 | | | | | | | | | | | | | | | | | | | | | | | | | | | | | | | | | | | | | | | | | | | | | | | | | | | | | | | | | | | | | | | | | | | | | | | |
| 04 | 2250 | 14 | 450 | | | | | | | | | | | | | | | | | | | | | | | | | | | | | | | | | | | | | | | | | | | | | | | | | | | | | | | | | | | | | | | | | | | | | | | |
| 05 | 1800 | 15 | 428 | | | | | | | | | | | | | | | | | | | | | | | | | | | | | | | | | | | | | | | | | | | | | | | | | | | | | | | | | | | | | | | | | | | | | | | |
| 06 | 1500 | 16 | 409 | | | | | | | | | | | | | | | | | | | | | | | | | | | | | | | | | | | | | | | | | | | | | | | | | | | | | | | | | | | | | | | | | | | | | | | |
| 07 | 1285 | 17 | 391 | | | | | | | | | | | | | | | | | | | | | | | | | | | | | | | | | | | | | | | | | | | | | | | | | | | | | | | | | | | | | | | | | | | | | | | |
| 08 | 1125 | 18 | 375 | | | | | | | | | | | | | | | | | | | | | | | | | | | | | | | | | | | | | | | | | | | | | | | | | | | | | | | | | | | | | | | | | | | | | | | |
| 09 | 1000 | 19 | 360 | | | | | | | | | | | | | | | | | | | | | | | | | | | | | | | | | | | | | | | | | | | | | | | | | | | | | | | | | | | | | | | | | | | | | | | |
| 0A | 900 | 1A | 346 | | | | | | | | | | | | | | | | | | | | | | | | | | | | | | | | | | | | | | | | | | | | | | | | | | | | | | | | | | | | | | | | | | | | | | | |
| 0B | 818 | 1B | 333 | | | | | | | | | | | | | | | | | | | | | | | | | | | | | | | | | | | | | | | | | | | | | | | | | | | | | | | | | | | | | | | | | | | | | | | |
| 0C | 750 | 1C | 321 | | | | | | | | | | | | | | | | | | | | | | | | | | | | | | | | | | | | | | | | | | | | | | | | | | | | | | | | | | | | | | | | | | | | | | | |
| 0D | 692 | 1D | 310 | | | | | | | | | | | | | | | | | | | | | | | | | | | | | | | | | | | | | | | | | | | | | | | | | | | | | | | | | | | | | | | | | | | | | | | |
| 0E | 642 | 1E | 300 | | | | | | | | | | | | | | | | | | | | | | | | | | | | | | | | | | | | | | | | | | | | | | | | | | | | | | | | | | | | | | | | | | | | | | | |
| 0F | 600 | 1F | 290 | | | | | | | | | | | | | | | | | | | | | | | | | | | | | | | | | | | | | | | | | | | | | | | | | | | | | | | | | | | | | | | | | | | | | | | |

5. PARAMETERS

| No./symbol/name | Setting digit | Function | Initial value [unit] | Control mode | | | | | | | |
|--|------------------------|---|----------------------|-----------------------|------------------------|-----------------------|--------|-----------------------|--------|------------------------|--|
| | | | | P | S | T | | | | | |
| PB18 LPF Low-pass filter setting | | Set the low-pass filter. The following shows a relation of a required parameter to this parameter. Setting range: 100 to 18000 | 3141 [rad/s] | <input type="radio"/> | <input type="radio"/> | <input type="radio"/> | | | | | |
| | | <table border="1"> <thead> <tr> <th>[Pr. PB23]</th> <th>[Pr. PB18]</th> </tr> </thead> <tbody> <tr> <td>-- 0 _ (Initial value)</td> <td>Automatic setting</td> </tr> <tr> <td>-- 1 _</td> <td>Setting value enabled</td> </tr> <tr> <td>-- 2 _</td> <td>Setting value disabled</td> </tr> </tbody> </table> | [Pr. PB23] | [Pr. PB18] | -- 0 _ (Initial value) | Automatic setting | -- 1 _ | Setting value enabled | -- 2 _ | Setting value disabled | |
| [Pr. PB23] | [Pr. PB18] | | | | | | | | | | |
| -- 0 _ (Initial value) | Automatic setting | | | | | | | | | | |
| -- 1 _ | Setting value enabled | | | | | | | | | | |
| -- 2 _ | Setting value disabled | | | | | | | | | | |
| PB19 VRF11 Vibration suppression control 1 - Vibration frequency | | Set the vibration frequency for vibration suppression control 1 to suppress low-frequency machine vibration. When "Vibration suppression control 1 tuning mode selection" is "Automatic setting (_ _ _ 1)" in [Pr. PB02], this parameter will be set automatically. Set manually for "Manual setting (_ _ _ 2)". Refer to section 7.1.5 for details. Setting range: 0.1 to 300.0 | 100.0 [Hz] | <input type="radio"/> | <input type="radio"/> | <input type="radio"/> | | | | | |
| PB20 VRF12 Vibration suppression control 1 - Resonance frequency | | Set the resonance frequency for vibration suppression control 1 to suppress low-frequency machine vibration. When "Vibration suppression control 1 tuning mode selection" is "Automatic setting (_ _ _ 1)" in [Pr. PB02], this parameter will be set automatically. Set manually for "Manual setting (_ _ _ 2)". Refer to section 7.1.5 for details. Setting range: 0.1 to 300.0 | 100.0 [Hz] | <input type="radio"/> | <input type="radio"/> | <input type="radio"/> | | | | | |
| PB21 VRF13 Vibration suppression control 1 - Vibration frequency damping | | Set a damping of the vibration frequency for vibration suppression control 1 to suppress low-frequency machine vibration. When "Vibration suppression control 1 tuning mode selection" is "Automatic setting (_ _ _ 1)" in [Pr. PB02], this parameter will be set automatically. Set manually for "Manual setting (_ _ _ 2)". Refer to section 7.1.5 for details. Setting range: 0.00 to 0.30 | 0.00 | <input type="radio"/> | <input type="radio"/> | <input type="radio"/> | | | | | |
| PB22 VRF14 Vibration suppression control 1 - Resonance frequency damping | | Set a damping of the resonance frequency for vibration suppression control 1 to suppress low-frequency machine vibration. When "Vibration suppression control 1 tuning mode selection" is "Automatic setting (_ _ _ 1)" in [Pr. PB02], this parameter will be set automatically. Set manually for "Manual setting (_ _ _ 2)". Refer to section 7.1.5 for details. Setting range: 0.00 to 0.30 | 0.00 | <input type="radio"/> | <input type="radio"/> | <input type="radio"/> | | | | | |
| PB23 VFBF Low-pass filter selection | -- _ x | Shaft resonance suppression filter selection Select the shaft resonance suppression filter. 0: Automatic setting 1: Manual setting 2: Disabled When you select "Enabled (_ _ _ 1)" of "Machine resonance suppression filter 4 selection" in [Pr. PB49], the shaft resonance suppression filter is not available. | 0h | <input type="radio"/> | <input type="radio"/> | <input type="radio"/> | | | | | |
| | _ _ x _ | Low-pass filter selection Select the low-pass filter. 0: Automatic setting 1: Manual setting 2: Disabled | 0h | <input type="radio"/> | <input type="radio"/> | <input type="radio"/> | | | | | |
| | _ x _ _ | For manufacturer setting | 0h | <input type="radio"/> | <input type="radio"/> | <input type="radio"/> | | | | | |
| | x _ _ _ | | 0h | <input type="radio"/> | <input type="radio"/> | <input type="radio"/> | | | | | |

5. PARAMETERS

| No./symbol/name | Setting digit | Function | Initial value [unit] | Control mode | | |
|--|--|--|------------------------------------|-----------------------|-----------------------|---|
| | | | | P | S | T |
| PB24 *MVS Slight vibration suppression control | ___x | Slight vibration suppression control selection Select the slight vibration suppression control. 0: Disabled 1: Enabled To enable the slight vibration suppression control, select "Manual mode (___3)" of "Gain adjustment mode selection" in [Pr. PA08]. Slight vibration suppression control cannot be used in the speed control mode. | 0h | <input type="radio"/> | | |
| | __x_ | For manufacturer setting | 0h | | | |
| | _x__ | | 0h | | | |
| | x___ | | 0h | | | |
| PB25 *BOP1 Function selection B-1 | ___x | For manufacturer setting | 0h | | | |
| | __x_ | Position acceleration/deceleration filter type selection Select the position acceleration/deceleration filter type. 0: Primary delay 1: Linear acceleration/deceleration When you select "Linear acceleration/deceleration", do not switch the control mode. Doing so will cause the servo motor to make a sudden stop at the time of control mode switching or restart. | 0h | <input type="radio"/> | | |
| | _x__ | For manufacturer setting | 0h | | | |
| | x___ | | 0h | | | |
| PB26 *CDP Gain switching function | Select the gain switching condition. Set conditions to enable the gain switching values set in [Pr. PB29] to [Pr. PB36] and [Pr. PB56] to [Pr. PB60]. | | | | | |
| | ___x | Gain switching selection 0: Disabled 1: Input device (gain switching (CDP)) 2: Command frequency 3: Droop pulses 4: Servo motor speed | 0h | <input type="radio"/> | <input type="radio"/> | |
| | __x_ | Gain switching condition selection 0: Gain after switching is enabled with gain switching condition or more 1: Gain after switching is enabled with gain switching condition or less | 0h | <input type="radio"/> | <input type="radio"/> | |
| | _x__ | For manufacturer setting | 0h | | | |
| | x___ | | 0h | | | |
| PB27 CDL Gain switching condition | | This is used to set the value of gain switching (command frequency, droop pulses, and servo motor speed) selected in [Pr. PB26]. The set value unit differs depending on the switching condition item. (Refer to section 7.2.3) Setting range: 0 to 9999 | 10 [kpps/ [pulse/ [r/min] | <input type="radio"/> | <input type="radio"/> | |
| PB28 CDT Gain switching time constant | | This is used to set the time constant at which the gains will change in response to the conditions set in [Pr. PB26] and [Pr. PB27]. Setting range: 0 to 100 | 1 [ms] | <input type="radio"/> | <input type="radio"/> | |
| PB29 GD2B Load to motor inertia ratio after gain switching | | This is used to set the load to motor inertia ratio when gain switching is enabled. This parameter is enabled only when you select "Manual mode (___3)" of "Gain adjustment mode selection" in [Pr. PA08]. Setting range: 0.00 to 300.00 | 7.00 Multiplier (×1) | <input type="radio"/> | <input type="radio"/> | |
| PB30 PG2B Position loop gain after gain switching | | Set the position loop gain when the gain switching is enabled. When you set a value less than 1.0 rad/s, the value will be the same as [Pr. PB08]. This parameter is enabled only when you select "Manual mode (___3)" of "Gain adjustment mode selection" in [Pr. PA08]. Setting range: 0.0 to 2000.0 | 0.0 [rad/s] | <input type="radio"/> | | |

5. PARAMETERS

| No./symbol/name | Setting digit | Function | Initial value [unit] | Control mode | | |
|---|---------------|--|----------------------|-----------------------|-----------------------|-----------------------|
| | | | | P | S | T |
| PB31 VG2B Speed loop gain after gain switching | | Set the speed loop gain when the gain switching is enabled. When you set a value less than 20 rad/s, the value will be the same as [Pr. PB09]. This parameter is enabled only when you select "Manual mode (_ _ _ 3)" of "Gain adjustment mode selection" in [Pr. PA08]. Setting range: 0 to 65535 | 0 [rad/s] | <input type="radio"/> | <input type="radio"/> | <input type="radio"/> |
| PB32 VICB Speed integral compensation after gain switching | | Set the speed integral compensation when the gain changing is valid. When you set a value less than 0.1 ms, the value will be the same as [Pr. PB10]. This parameter is enabled only when you select "Manual mode (_ _ _ 3)" of "Gain adjustment mode selection" in [Pr. PA08]. Setting range: 0.0 to 5000.0 | 0.0 [ms] | <input type="radio"/> | <input type="radio"/> | <input type="radio"/> |
| PB33 VRF1B Vibration suppression control 1 - Vibration frequency after gain switching | | Set the vibration frequency for vibration suppression control 1 when the gain switching is enabled. When you set a value less than 0.1 Hz, the value will be the same as [Pr. PB19]. This parameter will be enabled only when the following conditions are fulfilled. <ul style="list-style-type: none"> ▪ "Gain adjustment mode selection" in [Pr. PA08] is "Manual mode (_ _ _ 3)". ▪ "Vibration suppression control 1 tuning mode selection" in [Pr. PB02] is "Manual setting (_ _ _ 2)". ▪ "Gain switching selection" in [Pr. PB26] is "Input device (gain switching (CDP)) (_ _ _ 1)". Switching during driving may cause a shock. Be sure to switch them after the servo motor stops. Setting range: 0.0 to 300.0 | 0.0 [Hz] | <input type="radio"/> | <input type="radio"/> | <input type="radio"/> |
| PB34 VRF2B Vibration suppression control 1 - Resonance frequency after gain switching | | Set the resonance frequency for vibration suppression control 1 when the gain switching is enabled. When you set a value less than 0.1 Hz, the value will be the same as [Pr. PB20]. This parameter will be enabled only when the following conditions are fulfilled. <ul style="list-style-type: none"> ▪ "Gain adjustment mode selection" in [Pr. PA08] is "Manual mode (_ _ _ 3)". ▪ "Vibration suppression control 1 tuning mode selection" in [Pr. PB02] is "Manual setting (_ _ _ 2)". ▪ "Gain switching selection" in [Pr. PB26] is "Input device (gain switching (CDP)) (_ _ _ 1)". Switching during driving may cause a shock. Be sure to switch them after the servo motor stops. Setting range: 0.0 to 300.0 | 0.0 [Hz] | <input type="radio"/> | <input type="radio"/> | <input type="radio"/> |
| PB35 VRF3B Vibration suppression control 1 - Vibration frequency damping after gain switching | | Set a damping of the vibration frequency for vibration suppression control 1 when the gain switching is enabled. This parameter will be enabled only when the following conditions are fulfilled. <ul style="list-style-type: none"> ▪ "Gain adjustment mode selection" in [Pr. PA08] is "Manual mode (_ _ _ 3)". ▪ "Vibration suppression control 1 tuning mode selection" in [Pr. PB02] is "Manual setting (_ _ _ 2)". ▪ "Gain switching selection" in [Pr. PB26] is "Input device (gain switching (CDP)) (_ _ _ 1)". Switching during driving may cause a shock. Be sure to switch them after the servo motor stops. Setting range: 0.00 to 0.30 | 0.00 | <input type="radio"/> | <input type="radio"/> | <input type="radio"/> |

5. PARAMETERS

| No./symbol/name | Setting digit | Function | Initial value [unit] | Control mode | | | | | | | | | | | | | | | | | | | | | | | | | | | | | | | | | | | | | | | | | | | | | | | | | | | | | | | | | | | | | | | | | | | | | | | | | | | | | | | | | | | | | | | | | | | | | | | | | | | | | | | | | | | | | | | | | | | | | | | | | | | | | | | | | | | | | | | | | | | | | | | | | | | | | | | | | | | | | | | | | | | | | | | | | | | | | | | | | | | | | | | | | | | | | | | | | | | | | | | | |
|--|----------------|---|----------------------|--------------|----------------|---|---------|----------------|---------|----------------|---------|----------------|----|----------|----|----|----|------|----|------|----|----|----|------|----|------|----|----|----|------|----|-----|----|----|----|------|----|-----|----|----|----|------|----|-----|----|----|----|------|----|-----|----|----|----|------|----|-----|----|----|----|------|----|-----|----|----|----|------|----|-----|----|----|----|------|----|-----|----|----|----|------|----|-----|----|----|----|------|----|-----|----|----|----|----|----|-----|----|----|----|-----|----|-----|----|----|----|-----|----|-----|----|----|----|-----|----|-----|----|------|----|-----|----|-----|----|------|----|-----|----|-----|----|------|----|-----|----|-----|----|------|----|-----|----|-----|----|------|----|-----|----|-----|----|------|----|-----|----|-----|----|------|----|-----|----|----|----|------|----|-----|----|----|----|------|----|-----|----|----|----|------|----|-----|----|----|----|------|----|-----|----|----|----|------|----|-----|----|----|----|------|----|-----|----|----|----|------|----|-----|----|----|----|------|----|-----|----|----|----|------|----|-----|
| | | | | P | S | T | | | | | | | | | | | | | | | | | | | | | | | | | | | | | | | | | | | | | | | | | | | | | | | | | | | | | | | | | | | | | | | | | | | | | | | | | | | | | | | | | | | | | | | | | | | | | | | | | | | | | | | | | | | | | | | | | | | | | | | | | | | | | | | | | | | | | | | | | | | | | | | | | | | | | | | | | | | | | | | | | | | | | | | | | | | | | | | | | | | | | | | | | | | | | | | | | | | | | | |
| PB36 VRF4B Vibration suppression control 1 - Resonance frequency damping after gain switching | | <p>Set a damping of the resonance frequency for vibration suppression control 1 when the gain switching is enabled.</p> <p>This parameter will be enabled only when the following conditions are fulfilled.</p> <ul style="list-style-type: none"> • "Gain adjustment mode selection" in [Pr. PA08] is "Manual mode (_ _ _ 3)". • "Vibration suppression control 1 tuning mode selection" in [Pr. PB02] is "Manual setting (_ _ _ 2)". • "Gain switching selection" in [Pr. PB26] is "Input device (gain switching (CDP)) (_ _ _ 1)". <p>Switching during driving may cause a shock. Be sure to switch them after the servo motor stops.</p> <p>Setting range: 0.00 to 0.30</p> | 0.00 | ○ | | | | | | | | | | | | | | | | | | | | | | | | | | | | | | | | | | | | | | | | | | | | | | | | | | | | | | | | | | | | | | | | | | | | | | | | | | | | | | | | | | | | | | | | | | | | | | | | | | | | | | | | | | | | | | | | | | | | | | | | | | | | | | | | | | | | | | | | | | | | | | | | | | | | | | | | | | | | | | | | | | | | | | | | | | | | | | | | | | | | | | | | | | | | | | | | | | | | | | | | |
| PB45 CNHF Command notch filter | | Set the command notch filter. | | | | | | | | | | | | | | | | | | | | | | | | | | | | | | | | | | | | | | | | | | | | | | | | | | | | | | | | | | | | | | | | | | | | | | | | | | | | | | | | | | | | | | | | | | | | | | | | | | | | | | | | | | | | | | | | | | | | | | | | | | | | | | | | | | | | | | | | | | | | | | | | | | | | | | | | | | | | | | | | | | | | | | | | | | | | | | | | | | | | | | | | | | | | | | | | | | | | | | | | | | |
| | _ _ x x | Command notch filter setting frequency selection Refer to table 5.6 for the relation of setting values to frequency. | 00h | ○ | | | | | | | | | | | | | | | | | | | | | | | | | | | | | | | | | | | | | | | | | | | | | | | | | | | | | | | | | | | | | | | | | | | | | | | | | | | | | | | | | | | | | | | | | | | | | | | | | | | | | | | | | | | | | | | | | | | | | | | | | | | | | | | | | | | | | | | | | | | | | | | | | | | | | | | | | | | | | | | | | | | | | | | | | | | | | | | | | | | | | | | | | | | | | | | | | | | | | | | | |
| | _ x _ _ | Notch depth selection Refer to table 5.7 for details. | 0h | ○ | | | | | | | | | | | | | | | | | | | | | | | | | | | | | | | | | | | | | | | | | | | | | | | | | | | | | | | | | | | | | | | | | | | | | | | | | | | | | | | | | | | | | | | | | | | | | | | | | | | | | | | | | | | | | | | | | | | | | | | | | | | | | | | | | | | | | | | | | | | | | | | | | | | | | | | | | | | | | | | | | | | | | | | | | | | | | | | | | | | | | | | | | | | | | | | | | | | | | | | | |
| | x _ _ _ | For manufacturer setting | 0h | | | | | | | | | | | | | | | | | | | | | | | | | | | | | | | | | | | | | | | | | | | | | | | | | | | | | | | | | | | | | | | | | | | | | | | | | | | | | | | | | | | | | | | | | | | | | | | | | | | | | | | | | | | | | | | | | | | | | | | | | | | | | | | | | | | | | | | | | | | | | | | | | | | | | | | | | | | | | | | | | | | | | | | | | | | | | | | | | | | | | | | | | | | | | | | | | | | | | | | | | |
| <p>Table 5.6 Command notch filter setting frequency selection</p> <table border="1"> <thead> <tr> <th>Setting</th> <th>Frequency [Hz]</th> <th>Setting</th> <th>Frequency [Hz]</th> <th>Setting</th> <th>Frequency [Hz]</th> </tr> </thead> <tbody> <tr><td>00</td><td>Disabled</td><td>20</td><td>70</td><td>40</td><td>17.6</td></tr> <tr><td>01</td><td>2250</td><td>21</td><td>66</td><td>41</td><td>16.5</td></tr> <tr><td>02</td><td>1125</td><td>22</td><td>62</td><td>42</td><td>15.6</td></tr> <tr><td>03</td><td>750</td><td>23</td><td>59</td><td>43</td><td>14.8</td></tr> <tr><td>04</td><td>562</td><td>24</td><td>56</td><td>44</td><td>14.1</td></tr> <tr><td>05</td><td>450</td><td>25</td><td>53</td><td>45</td><td>13.4</td></tr> <tr><td>06</td><td>375</td><td>26</td><td>51</td><td>46</td><td>12.8</td></tr> <tr><td>07</td><td>321</td><td>27</td><td>48</td><td>47</td><td>12.2</td></tr> <tr><td>08</td><td>281</td><td>28</td><td>46</td><td>48</td><td>11.7</td></tr> <tr><td>09</td><td>250</td><td>29</td><td>45</td><td>49</td><td>11.3</td></tr> <tr><td>0A</td><td>225</td><td>2A</td><td>43</td><td>4A</td><td>10.8</td></tr> <tr><td>0B</td><td>204</td><td>2B</td><td>41</td><td>4B</td><td>10.4</td></tr> <tr><td>0C</td><td>187</td><td>2C</td><td>40</td><td>4C</td><td>10</td></tr> <tr><td>0D</td><td>173</td><td>2D</td><td>38</td><td>4D</td><td>9.7</td></tr> <tr><td>0E</td><td>160</td><td>2E</td><td>37</td><td>4E</td><td>9.4</td></tr> <tr><td>0F</td><td>150</td><td>2F</td><td>36</td><td>4F</td><td>9.1</td></tr> <tr><td>10</td><td>140</td><td>30</td><td>35.2</td><td>50</td><td>8.8</td></tr> <tr><td>11</td><td>132</td><td>31</td><td>33.1</td><td>51</td><td>8.3</td></tr> <tr><td>12</td><td>125</td><td>32</td><td>31.3</td><td>52</td><td>7.8</td></tr> <tr><td>13</td><td>118</td><td>33</td><td>29.6</td><td>53</td><td>7.4</td></tr> <tr><td>14</td><td>112</td><td>34</td><td>28.1</td><td>54</td><td>7.0</td></tr> <tr><td>15</td><td>107</td><td>35</td><td>26.8</td><td>55</td><td>6.7</td></tr> <tr><td>16</td><td>102</td><td>36</td><td>25.6</td><td>56</td><td>6.4</td></tr> <tr><td>17</td><td>97</td><td>37</td><td>24.5</td><td>57</td><td>6.1</td></tr> <tr><td>18</td><td>93</td><td>38</td><td>23.4</td><td>58</td><td>5.9</td></tr> <tr><td>19</td><td>90</td><td>39</td><td>22.5</td><td>59</td><td>5.6</td></tr> <tr><td>1A</td><td>86</td><td>3A</td><td>21.6</td><td>5A</td><td>5.4</td></tr> <tr><td>1B</td><td>83</td><td>3B</td><td>20.8</td><td>5B</td><td>5.2</td></tr> <tr><td>1C</td><td>80</td><td>3C</td><td>20.1</td><td>5C</td><td>5.0</td></tr> <tr><td>1D</td><td>77</td><td>3D</td><td>19.4</td><td>5D</td><td>4.9</td></tr> <tr><td>1E</td><td>75</td><td>3E</td><td>18.8</td><td>5E</td><td>4.7</td></tr> <tr><td>1F</td><td>72</td><td>3F</td><td>18.2</td><td>5F</td><td>4.5</td></tr> </tbody> </table> | | | | | | | Setting | Frequency [Hz] | Setting | Frequency [Hz] | Setting | Frequency [Hz] | 00 | Disabled | 20 | 70 | 40 | 17.6 | 01 | 2250 | 21 | 66 | 41 | 16.5 | 02 | 1125 | 22 | 62 | 42 | 15.6 | 03 | 750 | 23 | 59 | 43 | 14.8 | 04 | 562 | 24 | 56 | 44 | 14.1 | 05 | 450 | 25 | 53 | 45 | 13.4 | 06 | 375 | 26 | 51 | 46 | 12.8 | 07 | 321 | 27 | 48 | 47 | 12.2 | 08 | 281 | 28 | 46 | 48 | 11.7 | 09 | 250 | 29 | 45 | 49 | 11.3 | 0A | 225 | 2A | 43 | 4A | 10.8 | 0B | 204 | 2B | 41 | 4B | 10.4 | 0C | 187 | 2C | 40 | 4C | 10 | 0D | 173 | 2D | 38 | 4D | 9.7 | 0E | 160 | 2E | 37 | 4E | 9.4 | 0F | 150 | 2F | 36 | 4F | 9.1 | 10 | 140 | 30 | 35.2 | 50 | 8.8 | 11 | 132 | 31 | 33.1 | 51 | 8.3 | 12 | 125 | 32 | 31.3 | 52 | 7.8 | 13 | 118 | 33 | 29.6 | 53 | 7.4 | 14 | 112 | 34 | 28.1 | 54 | 7.0 | 15 | 107 | 35 | 26.8 | 55 | 6.7 | 16 | 102 | 36 | 25.6 | 56 | 6.4 | 17 | 97 | 37 | 24.5 | 57 | 6.1 | 18 | 93 | 38 | 23.4 | 58 | 5.9 | 19 | 90 | 39 | 22.5 | 59 | 5.6 | 1A | 86 | 3A | 21.6 | 5A | 5.4 | 1B | 83 | 3B | 20.8 | 5B | 5.2 | 1C | 80 | 3C | 20.1 | 5C | 5.0 | 1D | 77 | 3D | 19.4 | 5D | 4.9 | 1E | 75 | 3E | 18.8 | 5E | 4.7 | 1F | 72 | 3F | 18.2 | 5F | 4.5 |
| Setting | Frequency [Hz] | Setting | Frequency [Hz] | Setting | Frequency [Hz] | | | | | | | | | | | | | | | | | | | | | | | | | | | | | | | | | | | | | | | | | | | | | | | | | | | | | | | | | | | | | | | | | | | | | | | | | | | | | | | | | | | | | | | | | | | | | | | | | | | | | | | | | | | | | | | | | | | | | | | | | | | | | | | | | | | | | | | | | | | | | | | | | | | | | | | | | | | | | | | | | | | | | | | | | | | | | | | | | | | | | | | | | | | | | | | | | | | | | | | |
| 00 | Disabled | 20 | 70 | 40 | 17.6 | | | | | | | | | | | | | | | | | | | | | | | | | | | | | | | | | | | | | | | | | | | | | | | | | | | | | | | | | | | | | | | | | | | | | | | | | | | | | | | | | | | | | | | | | | | | | | | | | | | | | | | | | | | | | | | | | | | | | | | | | | | | | | | | | | | | | | | | | | | | | | | | | | | | | | | | | | | | | | | | | | | | | | | | | | | | | | | | | | | | | | | | | | | | | | | | | | | | | | | |
| 01 | 2250 | 21 | 66 | 41 | 16.5 | | | | | | | | | | | | | | | | | | | | | | | | | | | | | | | | | | | | | | | | | | | | | | | | | | | | | | | | | | | | | | | | | | | | | | | | | | | | | | | | | | | | | | | | | | | | | | | | | | | | | | | | | | | | | | | | | | | | | | | | | | | | | | | | | | | | | | | | | | | | | | | | | | | | | | | | | | | | | | | | | | | | | | | | | | | | | | | | | | | | | | | | | | | | | | | | | | | | | | | |
| 02 | 1125 | 22 | 62 | 42 | 15.6 | | | | | | | | | | | | | | | | | | | | | | | | | | | | | | | | | | | | | | | | | | | | | | | | | | | | | | | | | | | | | | | | | | | | | | | | | | | | | | | | | | | | | | | | | | | | | | | | | | | | | | | | | | | | | | | | | | | | | | | | | | | | | | | | | | | | | | | | | | | | | | | | | | | | | | | | | | | | | | | | | | | | | | | | | | | | | | | | | | | | | | | | | | | | | | | | | | | | | | | |
| 03 | 750 | 23 | 59 | 43 | 14.8 | | | | | | | | | | | | | | | | | | | | | | | | | | | | | | | | | | | | | | | | | | | | | | | | | | | | | | | | | | | | | | | | | | | | | | | | | | | | | | | | | | | | | | | | | | | | | | | | | | | | | | | | | | | | | | | | | | | | | | | | | | | | | | | | | | | | | | | | | | | | | | | | | | | | | | | | | | | | | | | | | | | | | | | | | | | | | | | | | | | | | | | | | | | | | | | | | | | | | | | |
| 04 | 562 | 24 | 56 | 44 | 14.1 | | | | | | | | | | | | | | | | | | | | | | | | | | | | | | | | | | | | | | | | | | | | | | | | | | | | | | | | | | | | | | | | | | | | | | | | | | | | | | | | | | | | | | | | | | | | | | | | | | | | | | | | | | | | | | | | | | | | | | | | | | | | | | | | | | | | | | | | | | | | | | | | | | | | | | | | | | | | | | | | | | | | | | | | | | | | | | | | | | | | | | | | | | | | | | | | | | | | | | | |
| 05 | 450 | 25 | 53 | 45 | 13.4 | | | | | | | | | | | | | | | | | | | | | | | | | | | | | | | | | | | | | | | | | | | | | | | | | | | | | | | | | | | | | | | | | | | | | | | | | | | | | | | | | | | | | | | | | | | | | | | | | | | | | | | | | | | | | | | | | | | | | | | | | | | | | | | | | | | | | | | | | | | | | | | | | | | | | | | | | | | | | | | | | | | | | | | | | | | | | | | | | | | | | | | | | | | | | | | | | | | | | | | |
| 06 | 375 | 26 | 51 | 46 | 12.8 | | | | | | | | | | | | | | | | | | | | | | | | | | | | | | | | | | | | | | | | | | | | | | | | | | | | | | | | | | | | | | | | | | | | | | | | | | | | | | | | | | | | | | | | | | | | | | | | | | | | | | | | | | | | | | | | | | | | | | | | | | | | | | | | | | | | | | | | | | | | | | | | | | | | | | | | | | | | | | | | | | | | | | | | | | | | | | | | | | | | | | | | | | | | | | | | | | | | | | | |
| 07 | 321 | 27 | 48 | 47 | 12.2 | | | | | | | | | | | | | | | | | | | | | | | | | | | | | | | | | | | | | | | | | | | | | | | | | | | | | | | | | | | | | | | | | | | | | | | | | | | | | | | | | | | | | | | | | | | | | | | | | | | | | | | | | | | | | | | | | | | | | | | | | | | | | | | | | | | | | | | | | | | | | | | | | | | | | | | | | | | | | | | | | | | | | | | | | | | | | | | | | | | | | | | | | | | | | | | | | | | | | | | |
| 08 | 281 | 28 | 46 | 48 | 11.7 | | | | | | | | | | | | | | | | | | | | | | | | | | | | | | | | | | | | | | | | | | | | | | | | | | | | | | | | | | | | | | | | | | | | | | | | | | | | | | | | | | | | | | | | | | | | | | | | | | | | | | | | | | | | | | | | | | | | | | | | | | | | | | | | | | | | | | | | | | | | | | | | | | | | | | | | | | | | | | | | | | | | | | | | | | | | | | | | | | | | | | | | | | | | | | | | | | | | | | | |
| 09 | 250 | 29 | 45 | 49 | 11.3 | | | | | | | | | | | | | | | | | | | | | | | | | | | | | | | | | | | | | | | | | | | | | | | | | | | | | | | | | | | | | | | | | | | | | | | | | | | | | | | | | | | | | | | | | | | | | | | | | | | | | | | | | | | | | | | | | | | | | | | | | | | | | | | | | | | | | | | | | | | | | | | | | | | | | | | | | | | | | | | | | | | | | | | | | | | | | | | | | | | | | | | | | | | | | | | | | | | | | | | |
| 0A | 225 | 2A | 43 | 4A | 10.8 | | | | | | | | | | | | | | | | | | | | | | | | | | | | | | | | | | | | | | | | | | | | | | | | | | | | | | | | | | | | | | | | | | | | | | | | | | | | | | | | | | | | | | | | | | | | | | | | | | | | | | | | | | | | | | | | | | | | | | | | | | | | | | | | | | | | | | | | | | | | | | | | | | | | | | | | | | | | | | | | | | | | | | | | | | | | | | | | | | | | | | | | | | | | | | | | | | | | | | | |
| 0B | 204 | 2B | 41 | 4B | 10.4 | | | | | | | | | | | | | | | | | | | | | | | | | | | | | | | | | | | | | | | | | | | | | | | | | | | | | | | | | | | | | | | | | | | | | | | | | | | | | | | | | | | | | | | | | | | | | | | | | | | | | | | | | | | | | | | | | | | | | | | | | | | | | | | | | | | | | | | | | | | | | | | | | | | | | | | | | | | | | | | | | | | | | | | | | | | | | | | | | | | | | | | | | | | | | | | | | | | | | | | |
| 0C | 187 | 2C | 40 | 4C | 10 | | | | | | | | | | | | | | | | | | | | | | | | | | | | | | | | | | | | | | | | | | | | | | | | | | | | | | | | | | | | | | | | | | | | | | | | | | | | | | | | | | | | | | | | | | | | | | | | | | | | | | | | | | | | | | | | | | | | | | | | | | | | | | | | | | | | | | | | | | | | | | | | | | | | | | | | | | | | | | | | | | | | | | | | | | | | | | | | | | | | | | | | | | | | | | | | | | | | | | | |
| 0D | 173 | 2D | 38 | 4D | 9.7 | | | | | | | | | | | | | | | | | | | | | | | | | | | | | | | | | | | | | | | | | | | | | | | | | | | | | | | | | | | | | | | | | | | | | | | | | | | | | | | | | | | | | | | | | | | | | | | | | | | | | | | | | | | | | | | | | | | | | | | | | | | | | | | | | | | | | | | | | | | | | | | | | | | | | | | | | | | | | | | | | | | | | | | | | | | | | | | | | | | | | | | | | | | | | | | | | | | | | | | |
| 0E | 160 | 2E | 37 | 4E | 9.4 | | | | | | | | | | | | | | | | | | | | | | | | | | | | | | | | | | | | | | | | | | | | | | | | | | | | | | | | | | | | | | | | | | | | | | | | | | | | | | | | | | | | | | | | | | | | | | | | | | | | | | | | | | | | | | | | | | | | | | | | | | | | | | | | | | | | | | | | | | | | | | | | | | | | | | | | | | | | | | | | | | | | | | | | | | | | | | | | | | | | | | | | | | | | | | | | | | | | | | | |
| 0F | 150 | 2F | 36 | 4F | 9.1 | | | | | | | | | | | | | | | | | | | | | | | | | | | | | | | | | | | | | | | | | | | | | | | | | | | | | | | | | | | | | | | | | | | | | | | | | | | | | | | | | | | | | | | | | | | | | | | | | | | | | | | | | | | | | | | | | | | | | | | | | | | | | | | | | | | | | | | | | | | | | | | | | | | | | | | | | | | | | | | | | | | | | | | | | | | | | | | | | | | | | | | | | | | | | | | | | | | | | | | |
| 10 | 140 | 30 | 35.2 | 50 | 8.8 | | | | | | | | | | | | | | | | | | | | | | | | | | | | | | | | | | | | | | | | | | | | | | | | | | | | | | | | | | | | | | | | | | | | | | | | | | | | | | | | | | | | | | | | | | | | | | | | | | | | | | | | | | | | | | | | | | | | | | | | | | | | | | | | | | | | | | | | | | | | | | | | | | | | | | | | | | | | | | | | | | | | | | | | | | | | | | | | | | | | | | | | | | | | | | | | | | | | | | | |
| 11 | 132 | 31 | 33.1 | 51 | 8.3 | | | | | | | | | | | | | | | | | | | | | | | | | | | | | | | | | | | | | | | | | | | | | | | | | | | | | | | | | | | | | | | | | | | | | | | | | | | | | | | | | | | | | | | | | | | | | | | | | | | | | | | | | | | | | | | | | | | | | | | | | | | | | | | | | | | | | | | | | | | | | | | | | | | | | | | | | | | | | | | | | | | | | | | | | | | | | | | | | | | | | | | | | | | | | | | | | | | | | | | |
| 12 | 125 | 32 | 31.3 | 52 | 7.8 | | | | | | | | | | | | | | | | | | | | | | | | | | | | | | | | | | | | | | | | | | | | | | | | | | | | | | | | | | | | | | | | | | | | | | | | | | | | | | | | | | | | | | | | | | | | | | | | | | | | | | | | | | | | | | | | | | | | | | | | | | | | | | | | | | | | | | | | | | | | | | | | | | | | | | | | | | | | | | | | | | | | | | | | | | | | | | | | | | | | | | | | | | | | | | | | | | | | | | | |
| 13 | 118 | 33 | 29.6 | 53 | 7.4 | | | | | | | | | | | | | | | | | | | | | | | | | | | | | | | | | | | | | | | | | | | | | | | | | | | | | | | | | | | | | | | | | | | | | | | | | | | | | | | | | | | | | | | | | | | | | | | | | | | | | | | | | | | | | | | | | | | | | | | | | | | | | | | | | | | | | | | | | | | | | | | | | | | | | | | | | | | | | | | | | | | | | | | | | | | | | | | | | | | | | | | | | | | | | | | | | | | | | | | |
| 14 | 112 | 34 | 28.1 | 54 | 7.0 | | | | | | | | | | | | | | | | | | | | | | | | | | | | | | | | | | | | | | | | | | | | | | | | | | | | | | | | | | | | | | | | | | | | | | | | | | | | | | | | | | | | | | | | | | | | | | | | | | | | | | | | | | | | | | | | | | | | | | | | | | | | | | | | | | | | | | | | | | | | | | | | | | | | | | | | | | | | | | | | | | | | | | | | | | | | | | | | | | | | | | | | | | | | | | | | | | | | | | | |
| 15 | 107 | 35 | 26.8 | 55 | 6.7 | | | | | | | | | | | | | | | | | | | | | | | | | | | | | | | | | | | | | | | | | | | | | | | | | | | | | | | | | | | | | | | | | | | | | | | | | | | | | | | | | | | | | | | | | | | | | | | | | | | | | | | | | | | | | | | | | | | | | | | | | | | | | | | | | | | | | | | | | | | | | | | | | | | | | | | | | | | | | | | | | | | | | | | | | | | | | | | | | | | | | | | | | | | | | | | | | | | | | | | |
| 16 | 102 | 36 | 25.6 | 56 | 6.4 | | | | | | | | | | | | | | | | | | | | | | | | | | | | | | | | | | | | | | | | | | | | | | | | | | | | | | | | | | | | | | | | | | | | | | | | | | | | | | | | | | | | | | | | | | | | | | | | | | | | | | | | | | | | | | | | | | | | | | | | | | | | | | | | | | | | | | | | | | | | | | | | | | | | | | | | | | | | | | | | | | | | | | | | | | | | | | | | | | | | | | | | | | | | | | | | | | | | | | | |
| 17 | 97 | 37 | 24.5 | 57 | 6.1 | | | | | | | | | | | | | | | | | | | | | | | | | | | | | | | | | | | | | | | | | | | | | | | | | | | | | | | | | | | | | | | | | | | | | | | | | | | | | | | | | | | | | | | | | | | | | | | | | | | | | | | | | | | | | | | | | | | | | | | | | | | | | | | | | | | | | | | | | | | | | | | | | | | | | | | | | | | | | | | | | | | | | | | | | | | | | | | | | | | | | | | | | | | | | | | | | | | | | | | |
| 18 | 93 | 38 | 23.4 | 58 | 5.9 | | | | | | | | | | | | | | | | | | | | | | | | | | | | | | | | | | | | | | | | | | | | | | | | | | | | | | | | | | | | | | | | | | | | | | | | | | | | | | | | | | | | | | | | | | | | | | | | | | | | | | | | | | | | | | | | | | | | | | | | | | | | | | | | | | | | | | | | | | | | | | | | | | | | | | | | | | | | | | | | | | | | | | | | | | | | | | | | | | | | | | | | | | | | | | | | | | | | | | | |
| 19 | 90 | 39 | 22.5 | 59 | 5.6 | | | | | | | | | | | | | | | | | | | | | | | | | | | | | | | | | | | | | | | | | | | | | | | | | | | | | | | | | | | | | | | | | | | | | | | | | | | | | | | | | | | | | | | | | | | | | | | | | | | | | | | | | | | | | | | | | | | | | | | | | | | | | | | | | | | | | | | | | | | | | | | | | | | | | | | | | | | | | | | | | | | | | | | | | | | | | | | | | | | | | | | | | | | | | | | | | | | | | | | |
| 1A | 86 | 3A | 21.6 | 5A | 5.4 | | | | | | | | | | | | | | | | | | | | | | | | | | | | | | | | | | | | | | | | | | | | | | | | | | | | | | | | | | | | | | | | | | | | | | | | | | | | | | | | | | | | | | | | | | | | | | | | | | | | | | | | | | | | | | | | | | | | | | | | | | | | | | | | | | | | | | | | | | | | | | | | | | | | | | | | | | | | | | | | | | | | | | | | | | | | | | | | | | | | | | | | | | | | | | | | | | | | | | | |
| 1B | 83 | 3B | 20.8 | 5B | 5.2 | | | | | | | | | | | | | | | | | | | | | | | | | | | | | | | | | | | | | | | | | | | | | | | | | | | | | | | | | | | | | | | | | | | | | | | | | | | | | | | | | | | | | | | | | | | | | | | | | | | | | | | | | | | | | | | | | | | | | | | | | | | | | | | | | | | | | | | | | | | | | | | | | | | | | | | | | | | | | | | | | | | | | | | | | | | | | | | | | | | | | | | | | | | | | | | | | | | | | | | |
| 1C | 80 | 3C | 20.1 | 5C | 5.0 | | | | | | | | | | | | | | | | | | | | | | | | | | | | | | | | | | | | | | | | | | | | | | | | | | | | | | | | | | | | | | | | | | | | | | | | | | | | | | | | | | | | | | | | | | | | | | | | | | | | | | | | | | | | | | | | | | | | | | | | | | | | | | | | | | | | | | | | | | | | | | | | | | | | | | | | | | | | | | | | | | | | | | | | | | | | | | | | | | | | | | | | | | | | | | | | | | | | | | | |
| 1D | 77 | 3D | 19.4 | 5D | 4.9 | | | | | | | | | | | | | | | | | | | | | | | | | | | | | | | | | | | | | | | | | | | | | | | | | | | | | | | | | | | | | | | | | | | | | | | | | | | | | | | | | | | | | | | | | | | | | | | | | | | | | | | | | | | | | | | | | | | | | | | | | | | | | | | | | | | | | | | | | | | | | | | | | | | | | | | | | | | | | | | | | | | | | | | | | | | | | | | | | | | | | | | | | | | | | | | | | | | | | | | |
| 1E | 75 | 3E | 18.8 | 5E | 4.7 | | | | | | | | | | | | | | | | | | | | | | | | | | | | | | | | | | | | | | | | | | | | | | | | | | | | | | | | | | | | | | | | | | | | | | | | | | | | | | | | | | | | | | | | | | | | | | | | | | | | | | | | | | | | | | | | | | | | | | | | | | | | | | | | | | | | | | | | | | | | | | | | | | | | | | | | | | | | | | | | | | | | | | | | | | | | | | | | | | | | | | | | | | | | | | | | | | | | | | | |
| 1F | 72 | 3F | 18.2 | 5F | 4.5 | | | | | | | | | | | | | | | | | | | | | | | | | | | | | | | | | | | | | | | | | | | | | | | | | | | | | | | | | | | | | | | | | | | | | | | | | | | | | | | | | | | | | | | | | | | | | | | | | | | | | | | | | | | | | | | | | | | | | | | | | | | | | | | | | | | | | | | | | | | | | | | | | | | | | | | | | | | | | | | | | | | | | | | | | | | | | | | | | | | | | | | | | | | | | | | | | | | | | | | |

5. PARAMETERS

| No./symbol/name | Setting digit | Function | Initial value [unit] | Control mode | | | | | | | | | | | | | | | | | | | | | | | | | | | | | | | | | | | | | | |
|---|--|---|----------------------|-----------------------|-----------------------|-----------------------|---------|------------|---------|------------|---|-------|---|------|---|-------|---|------|---|-------|---|------|---|-------|---|------|---|-------|---|------|---|-------|---|------|---|------|---|------|---|------|---|------|
| | | | | P | S | T | | | | | | | | | | | | | | | | | | | | | | | | | | | | | | | | | | | | |
| PB45 CNHF Command notch filter | <p style="text-align: center;">Table 5.7 Notch depth selection</p> <table border="1" style="margin-left: auto; margin-right: auto;"> <thead> <tr> <th>Setting</th> <th>Depth [dB]</th> <th>Setting</th> <th>Depth [dB]</th> </tr> </thead> <tbody> <tr> <td>0</td> <td>-40.0</td> <td>8</td> <td>-6.0</td> </tr> <tr> <td>1</td> <td>-24.1</td> <td>9</td> <td>-5.0</td> </tr> <tr> <td>2</td> <td>-18.1</td> <td>A</td> <td>-4.1</td> </tr> <tr> <td>3</td> <td>-14.5</td> <td>B</td> <td>-3.3</td> </tr> <tr> <td>4</td> <td>-12.0</td> <td>C</td> <td>-2.5</td> </tr> <tr> <td>5</td> <td>-10.1</td> <td>D</td> <td>-1.8</td> </tr> <tr> <td>6</td> <td>-8.5</td> <td>E</td> <td>-1.2</td> </tr> <tr> <td>7</td> <td>-7.2</td> <td>F</td> <td>-0.6</td> </tr> </tbody> </table> | | | | | | Setting | Depth [dB] | Setting | Depth [dB] | 0 | -40.0 | 8 | -6.0 | 1 | -24.1 | 9 | -5.0 | 2 | -18.1 | A | -4.1 | 3 | -14.5 | B | -3.3 | 4 | -12.0 | C | -2.5 | 5 | -10.1 | D | -1.8 | 6 | -8.5 | E | -1.2 | 7 | -7.2 | F | -0.6 |
| Setting | Depth [dB] | Setting | Depth [dB] | | | | | | | | | | | | | | | | | | | | | | | | | | | | | | | | | | | | | | | |
| 0 | -40.0 | 8 | -6.0 | | | | | | | | | | | | | | | | | | | | | | | | | | | | | | | | | | | | | | | |
| 1 | -24.1 | 9 | -5.0 | | | | | | | | | | | | | | | | | | | | | | | | | | | | | | | | | | | | | | | |
| 2 | -18.1 | A | -4.1 | | | | | | | | | | | | | | | | | | | | | | | | | | | | | | | | | | | | | | | |
| 3 | -14.5 | B | -3.3 | | | | | | | | | | | | | | | | | | | | | | | | | | | | | | | | | | | | | | | |
| 4 | -12.0 | C | -2.5 | | | | | | | | | | | | | | | | | | | | | | | | | | | | | | | | | | | | | | | |
| 5 | -10.1 | D | -1.8 | | | | | | | | | | | | | | | | | | | | | | | | | | | | | | | | | | | | | | | |
| 6 | -8.5 | E | -1.2 | | | | | | | | | | | | | | | | | | | | | | | | | | | | | | | | | | | | | | | |
| 7 | -7.2 | F | -0.6 | | | | | | | | | | | | | | | | | | | | | | | | | | | | | | | | | | | | | | | |
| PB46 NH3 Machine resonance suppression filter 3 | | Set the notch frequency of the machine resonance suppression filter 3. To enable the setting value, select "Enabled (___ 1)" of "Machine resonance suppression filter 3 selection" in [Pr. PB47]. Setting range: 10 to 4500 | 4500 [Hz] | <input type="radio"/> | <input type="radio"/> | <input type="radio"/> | | | | | | | | | | | | | | | | | | | | | | | | | | | | | | | | | | | | |
| PB47 NHQ3 Notch shape selection 3 | Set the shape of the machine resonance suppression filter 3. | | | | | | | | | | | | | | | | | | | | | | | | | | | | | | | | | | | | | | | | | |
| | ___ x | Machine resonance suppression filter 3 selection 0: Disabled 1: Enabled | 0h | <input type="radio"/> | <input type="radio"/> | <input type="radio"/> | | | | | | | | | | | | | | | | | | | | | | | | | | | | | | | | | | | | |
| | __ x _ | Notch depth selection 0: -40 dB 1: -14 dB 2: -8 dB 3: -4 dB | 0h | <input type="radio"/> | <input type="radio"/> | <input type="radio"/> | | | | | | | | | | | | | | | | | | | | | | | | | | | | | | | | | | | | |
| | _ x _ _ | Notch width selection 0: $\alpha = 2$ 1: $\alpha = 3$ 2: $\alpha = 4$ 3: $\alpha = 5$ | 0h | <input type="radio"/> | <input type="radio"/> | <input type="radio"/> | | | | | | | | | | | | | | | | | | | | | | | | | | | | | | | | | | | | |
| | x _ _ _ | For manufacturer setting | 0h | <input type="radio"/> | <input type="radio"/> | <input type="radio"/> | | | | | | | | | | | | | | | | | | | | | | | | | | | | | | | | | | | | |
| PB48 NH4 Machine resonance suppression filter 4 | | Set the notch frequency of the machine resonance suppression filter 4. To enable the setting value, select "Enabled (___ 1)" of "Machine resonance suppression filter 4 selection" in [Pr. PB49]. Setting range: 10 to 4500 | 4500 [Hz] | <input type="radio"/> | <input type="radio"/> | <input type="radio"/> | | | | | | | | | | | | | | | | | | | | | | | | | | | | | | | | | | | | |
| PB49 NHQ4 Notch shape selection 4 | Set the shape of the machine resonance suppression filter 4. | | | | | | | | | | | | | | | | | | | | | | | | | | | | | | | | | | | | | | | | | |
| | ___ x | Machine resonance suppression filter 4 selection 0: Disabled 1: Enabled When you select "Enabled" of this digit, [Pr. PB17 Shaft resonance suppression filter] is not available. | 0h | <input type="radio"/> | <input type="radio"/> | <input type="radio"/> | | | | | | | | | | | | | | | | | | | | | | | | | | | | | | | | | | | | |
| | __ x _ | Notch depth selection 0: -40 dB 1: -14 dB 2: -8 dB 3: -4 dB | 0h | <input type="radio"/> | <input type="radio"/> | <input type="radio"/> | | | | | | | | | | | | | | | | | | | | | | | | | | | | | | | | | | | | |
| | _ x _ _ | Notch width selection 0: $\alpha = 2$ 1: $\alpha = 3$ 2: $\alpha = 4$ 3: $\alpha = 5$ | 0h | <input type="radio"/> | <input type="radio"/> | <input type="radio"/> | | | | | | | | | | | | | | | | | | | | | | | | | | | | | | | | | | | | |
| | x _ _ _ | For manufacturer setting | 0h | <input type="radio"/> | <input type="radio"/> | <input type="radio"/> | | | | | | | | | | | | | | | | | | | | | | | | | | | | | | | | | | | | |

5. PARAMETERS

| No./symbol/name | Setting digit | Function | Initial value [unit] | Control mode | | |
|--|---------------|--|----------------------|-----------------------|-----------------------|-----------------------|
| | | | | P | S | T |
| PB50 NH5 Machine resonance suppression filter 5 | | Set the notch frequency of the machine resonance suppression filter 5. To enable the setting value, select "Enabled (_ _ _ 1)" of "Machine resonance suppression filter 5 selection" in [Pr. PB51]. Setting range: 10 to 4500 | 4500 [Hz] | <input type="radio"/> | <input type="radio"/> | <input type="radio"/> |
| PB51 NHQ5 Notch shape selection 5 | | Set the shape of the machine resonance suppression filter 5. When you select "Enabled (_ _ _ 1)" of "Robust filter selection" in [Pr. PE41], the machine resonance suppression filter 5 is not available. | | | | |
| | _ _ _ x | Machine resonance suppression filter 5 selection 0: Disabled 1: Enabled | 0h | <input type="radio"/> | <input type="radio"/> | <input type="radio"/> |
| | _ _ x _ | Notch depth selection 0: -40 dB 1: -14 dB 2: -8 dB 3: -4 dB | 0h | <input type="radio"/> | <input type="radio"/> | <input type="radio"/> |
| | _ x _ _ | Notch width selection 0: $\alpha = 2$ 1: $\alpha = 3$ 2: $\alpha = 4$ 3: $\alpha = 5$ | 0h | <input type="radio"/> | <input type="radio"/> | <input type="radio"/> |
| | x _ _ _ | For manufacturer setting | 0h | <input type="radio"/> | <input type="radio"/> | <input type="radio"/> |
| PB52 VRF21 Vibration suppression control 2 - Vibration frequency | | Set the vibration frequency for vibration suppression control 2 to suppress low-frequency machine vibration. When "Vibration suppression control 2 tuning mode selection" is "Automatic setting (_ _ 1 _)" in [Pr. PB02], this parameter will be set automatically. Set manually for "Manual setting (_ _ 2 _)". To enable the digit, select "3 inertia mode (_ _ _ 1)" of "Vibration suppression mode selection" in [Pr. PA24]. Setting range: 0.1 to 300.0 | 100.0 [Hz] | <input type="radio"/> | <input type="radio"/> | <input type="radio"/> |
| PB53 VRF22 Vibration suppression control 2 - Resonance frequency | | Set the resonance frequency for vibration suppression control 2 to suppress low-frequency machine vibration. When "Vibration suppression control 2 tuning mode selection" is "Automatic setting (_ _ 1 _)" in [Pr. PB02], this parameter will be set automatically. Set manually for "Manual setting (_ _ 2 _)". To enable the digit, select "3 inertia mode (_ _ _ 1)" of "Vibration suppression mode selection" in [Pr. PA24]. Setting range: 0.1 to 300.0 | 100.0 [Hz] | <input type="radio"/> | <input type="radio"/> | <input type="radio"/> |
| PB54 VRF23 Vibration suppression control 2 - Vibration frequency damping | | Set a damping of the vibration frequency for vibration suppression control 2 to suppress low-frequency machine vibration. When "Vibration suppression control 2 tuning mode selection" is "Automatic setting (_ _ 1 _)" in [Pr. PB02], this parameter will be set automatically. Set manually for "Manual setting (_ _ 2 _)". To enable the digit, select "3 inertia mode (_ _ _ 1)" of "Vibration suppression mode selection" in [Pr. PA24]. Setting range: 0.00 to 0.30 | 0.00 | <input type="radio"/> | <input type="radio"/> | <input type="radio"/> |
| PB55 VRF24 Vibration suppression control 2 - Resonance frequency damping | | Set a damping of the resonance frequency for vibration suppression control 2 to suppress low-frequency machine vibration. When "Vibration suppression control 2 tuning mode selection" is "Automatic setting (_ _ 1 _)" in [Pr. PB02], this parameter will be set automatically. Set manually for "Manual setting (_ _ 2 _)". To enable the digit, select "3 inertia mode (_ _ _ 1)" of "Vibration suppression mode selection" in [Pr. PA24]. Setting range: 0.00 to 0.30 | 0.00 | <input type="radio"/> | <input type="radio"/> | <input type="radio"/> |

5. PARAMETERS

| No./symbol/name | Setting digit | Function | Initial value [unit] | Control mode | | |
|--|---------------|---|----------------------|-----------------------|---|---|
| | | | | P | S | T |
| PB56 VRF21B Vibration suppression control 2 - Vibration frequency after gain switching | | <p>Set the vibration frequency for vibration suppression control 2 when the gain switching is enabled.</p> <p>When you set a value less than 0.1 Hz, the value will be the same as [Pr. PB52]. This parameter will be enabled only when the following conditions are fulfilled.</p> <ul style="list-style-type: none"> "Gain adjustment mode selection" in [Pr. PA08] is "Manual mode (_ _ _ 3)". "Vibration suppression mode selection" in [Pr. PA24] is "3 inertia mode (_ _ _ 1)". "Vibration suppression control 2 tuning mode selection" in [Pr. PB02] is "Manual setting (_ _ 2 _)". "Gain switching selection" in [Pr. PB26] is "Input device (gain switching (CDP)) (_ _ _ 1)". <p>Switching during driving may cause a shock. Be sure to switch them after the servo motor stops.</p> <p>Setting range: 0.0 to 300.0</p> | 0.0 [Hz] | <input type="radio"/> | | |
| PB57 VRF22B Vibration suppression control 2 - Resonance frequency after gain switching | | <p>Set the resonance frequency for vibration suppression control 2 when the gain switching is enabled.</p> <p>When you set a value less than 0.1 Hz, the value will be the same as [Pr. PB53]. This parameter will be enabled only when the following conditions are fulfilled.</p> <ul style="list-style-type: none"> "Gain adjustment mode selection" in [Pr. PA08] is "Manual mode (_ _ _ 3)". "Vibration suppression mode selection" in [Pr. PA24] is "3 inertia mode (_ _ _ 1)". "Vibration suppression control 2 tuning mode selection" in [Pr. PB02] is "Manual setting (_ _ 2 _)". "Gain switching selection" in [Pr. PB26] is "Input device (gain switching (CDP)) (_ _ _ 1)". <p>Switching during driving may cause a shock. Be sure to switch them after the servo motor stops.</p> <p>Setting range: 0.0 to 300.0</p> | 0.0 [Hz] | <input type="radio"/> | | |
| PB58 VRF23B Vibration suppression control 2 - Vibration frequency damping after gain switching | | <p>Set a damping of the vibration frequency for vibration suppression control 2 when the gain switching is enabled.</p> <p>This parameter will be enabled only when the following conditions are fulfilled.</p> <ul style="list-style-type: none"> "Gain adjustment mode selection" in [Pr. PA08] is "Manual mode (_ _ _ 3)". "Vibration suppression mode selection" in [Pr. PA24] is "3 inertia mode (_ _ _ 1)". "Vibration suppression control 2 tuning mode selection" in [Pr. PB02] is "Manual setting (_ _ 2 _)". "Gain switching selection" in [Pr. PB26] is "Input device (gain switching (CDP)) (_ _ _ 1)". <p>Switching during driving may cause a shock. Be sure to switch them after the servo motor stops.</p> <p>Setting range: 0.00 to 0.30</p> | 0.00 | <input type="radio"/> | | |
| PB59 VRF24B Vibration suppression control 2 - Resonance frequency damping after gain switching | | <p>Set a damping of the resonance frequency for vibration suppression control 2 when the gain switching is enabled.</p> <p>This parameter will be enabled only when the following conditions are fulfilled.</p> <ul style="list-style-type: none"> "Gain adjustment mode selection" in [Pr. PA08] is "Manual mode (_ _ _ 3)". "Vibration suppression mode selection" in [Pr. PA24] is "3 inertia mode (_ _ _ 1)". "Vibration suppression control 2 tuning mode selection" in [Pr. PB02] is "Manual setting (_ _ 2 _)". "Gain switching selection" in [Pr. PB26] is "Input device (gain switching (CDP)) (_ _ _ 1)". <p>Switching during driving may cause a shock. Be sure to switch them after the servo motor stops.</p> <p>Setting range: 0.00 to 0.30</p> | 0.00 | <input type="radio"/> | | |

5. PARAMETERS

| No./symbol/name | Setting digit | Function | Initial value [unit] | Control mode | | |
|--|---------------|---|----------------------|-----------------------|-----------------------|-----------------------|
| | | | | P | S | T |
| PB60 PG1B Model loop gain after gain switching | | <p>Set the model loop gain when the gain switching is enabled.</p> <p>When you set a value less than 1.0 rad/s, the value will be the same as [Pr. PB07].</p> <p>This parameter will be enabled only when the following conditions are fulfilled.</p> <ul style="list-style-type: none"> • "Gain adjustment mode selection" in [Pr. PA08] is "Manual mode (_ _ _ 3)". • "Gain switching selection" in [Pr. PB26] is "Input device (gain switching (CDP)) (_ _ _ 1)". <p>Switching during driving may cause a shock. Be sure to switch them after the servo motor stops.</p> <p>Setting range: 0.0 to 2000.0</p> | 0.0 [rad/s] | <input type="radio"/> | <input type="radio"/> | <input type="radio"/> |

5.2.3 Extension setting parameters ([Pr. PC_ _])

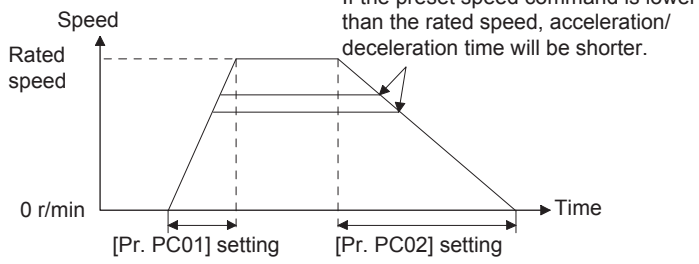
| No./symbol/name | Setting digit | Function | Initial value [unit] | Control mode | | |
|---|---------------|---|----------------------|-----------------------|-----------------------|-----------------------|
| | | | | P | S | T |
| PC01 STA Acceleration time constant | | <p>This is used to set the acceleration time required to reach the rated speed from 0 r/min in response to VC (Analog speed command) and [Pr. PC05 Internal speed command 1] to [Pr. PC11 Internal speed command 7].</p>  <p>For example for the servo motor of 3000 r/min rated speed, set 3000 (3s) to increase speed from 0 r/min to 1000 r/min in 1 second.</p> <p>Setting range: 0 to 50000</p> | 0 [ms] | <input type="radio"/> | <input type="radio"/> | <input type="radio"/> |
| PC02 STB Deceleration time constant | | <p>This is used to set the deceleration time required to reach the rated speed from 0 r/min in response to VC (Analog speed command) and [Pr. PC05 Internal speed command 1] to [Pr. PC11 Internal speed command 7].</p> <p>Setting range: 0 to 50000</p> | 0 [ms] | <input type="radio"/> | <input type="radio"/> | <input type="radio"/> |

5. PARAMETERS

| No./symbol/name | Setting digit | Function | Initial value [unit] | Control mode | | |
|--|---------------|---|----------------------|--------------|-----------------------|-----------------------|
| | | | | P | S | T |
| PC03 STC S-pattern acceleration/deceleration time constant | | <p>This is used to smooth start/stop of the servo motor. Set the time of the arc part for S-pattern acceleration/deceleration.</p> <p>STA: Acceleration time constant ([Pr. PC01]) STB: Deceleration time constant ([Pr. PC02]) STC: S-pattern acceleration/deceleration time constant ([Pr. PC03])</p> <p>Long setting of STA (acceleration time constant) or STB (deceleration time constant) may produce an error in the time of the arc part for the setting of the S-pattern acceleration/deceleration time constant. The upper limit value of the actual arc part time is limited by</p> $\frac{2000000}{STA} \text{ for acceleration or by } \frac{2000000}{STB} \text{ for deceleration.}$ <p>(Example) At the setting of STA 20000, STB 5000 and STC 200, the actual arc part times are as follows.</p> <p>During acceleration: 100 ms $\frac{2000000}{20000} = 100 \text{ [ms]} < 200 \text{ [ms]}$ Therefore, it will be limited to 100 [ms].</p> <p>During deceleration: 200 ms $\frac{2000000}{5000} = 400 \text{ [ms]} > 200 \text{ [ms]}$ Therefore, it will be 200 [ms] as you set.</p> <p>Setting range: 0 to 5000</p> | 0 [ms] | | <input type="radio"/> | <input type="radio"/> |
| PC04 TQC Torque command time constant | | <p>This is used to set the constant of a primary delay to the torque command.</p> <p>TQC: Torque command time constant</p> <p>Setting range: 0 to 50000</p> | 0 [ms] | | | <input type="radio"/> |

5. PARAMETERS

| No./symbol/name | Setting digit | Function | Initial value [unit] | Control mode | | |
|--|---------------|--|----------------------|--------------|-----------------------|-----------------------|
| | | | | P | S | T |
| PC05 SC1 Internal speed command 1/internal speed limit 1 | | This is used to set speed 1 of internal speed commands. Setting range: 0 to permissible instantaneous speed | 100 [r/min] | | <input type="radio"/> | |
| | | This is used to set speed 1 of internal speed limits. Setting range: 0 to permissible instantaneous speed | | | | <input type="radio"/> |
| PC06 SC2 Internal speed command 2/internal speed limit 2 | | This is used to set speed 2 of internal speed commands. Setting range: 0 to permissible instantaneous speed | 500 [r/min] | | <input type="radio"/> | |
| | | This is used to set speed 2 of internal speed limits. Setting range: 0 to permissible instantaneous speed | | | | <input type="radio"/> |
| PC07 SC3 Internal speed command 3/internal speed limit 3 | | This is used to set speed 3 of internal speed commands. Setting range: 0 to permissible instantaneous speed | 1000 [r/min] | | <input type="radio"/> | |
| | | This is used to set speed 3 of internal speed limits. Setting range: 0 to permissible instantaneous speed | | | | <input type="radio"/> |
| PC08 SC4 Internal speed command 4/internal speed limit 4 | | This is used to set speed 4 of internal speed commands. Setting range: 0 to permissible instantaneous speed | 200 [r/min] | | <input type="radio"/> | |
| | | This is used to set speed 4 of internal speed limits. Setting range: 0 to permissible instantaneous speed | | | | <input type="radio"/> |
| PC09 SC5 Internal speed command 5/internal speed limit 5 | | This is used to set speed 5 of internal speed commands. Setting range: 0 to permissible instantaneous speed | 300 [r/min] | | <input type="radio"/> | |
| | | This is used to set speed 5 of internal speed limits. Setting range: 0 to permissible instantaneous speed | | | | <input type="radio"/> |
| PC10 SC6 Internal speed command 6/internal speed limit 6 | | This is used to set speed 6 of internal speed commands. Setting range: 0 to permissible instantaneous speed | 500 [r/min] | | <input type="radio"/> | |
| | | This is used to set speed 6 of internal speed limits. Setting range: 0 to permissible instantaneous speed | | | | <input type="radio"/> |
| PC11 SC7 Internal speed command 7/internal speed limit 7 | | This is used to set speed 7 of internal speed commands. Setting range: 0 to permissible instantaneous speed | 800 [r/min] | | <input type="radio"/> | |
| | | This is used to set speed 7 of internal speed limits. Setting range: 0 to permissible instantaneous speed | | | | <input type="radio"/> |
| PC12 VCM Analog speed command - Maximum speed/Analog speed limit - Maximum speed | | This is used to set the speed at the maximum input voltage (10 V) of VC (Analog speed command). When "0" is set, the analog speed command maximum speed would be the rated speed of the servo motor connected. The following shows the speed for motorless operation of test operation. Setting range: 0 to 50000 | 0 [r/min] | | <input type="radio"/> | |
| | | This is used to set the speed at the maximum input voltage (10 V) of VLA (Analog speed limit). When "0" is set, the analog speed command maximum speed would be the rated speed of the servo motor connected. Setting range: 0 to 50000 | | | | <input type="radio"/> |

5. PARAMETERS

| No./symbol/name | Setting digit | Function | Initial value [unit] | Control mode | | | | | | | | | | | | | | | | | | | | | | | | | | | | | | | | | | | | |
|--|--|---|----------------------|--------------|---|---|---------------|------|----|-------------------------------------|----|------------------------------------|----|-------------------------------------|----|------------------------------------|----|---|----|--|----|---|----|--|----|---|----|--|----|--|----|---|----|--|----|--------------------------|----|-----------------------------------|----|--|
| | | | | P | S | T | | | | | | | | | | | | | | | | | | | | | | | | | | | | | | | | | | |
| PC13 TLC Analog torque command maximum output | | This is used to set the output torque at the analog torque command voltage (TC = ±8 V) of +8 V on the assumption that the maximum torque is 100.0%. For example, set 50.0 to output at the TC = +8 V. (maximum torque × 50/100) Setting range: 0.0 to 1000.0 | 100.0 [%] | | | ○ | | | | | | | | | | | | | | | | | | | | | | | | | | | | | | | | | | |
| PC14 MOD1 Analog monitor 1 output | __ x x | Analog monitor 1 output selection Used to selection the signal provided to MO1 (Analog monitor 1) output. Refer to app. 10 (3) for detection point of output selection. Refer to table 5.8 for settings. | 00h | ○ | ○ | ○ | | | | | | | | | | | | | | | | | | | | | | | | | | | | | | | | | | |
| | _ x _ _ | For manufacturer setting | 0h | | | | | | | | | | | | | | | | | | | | | | | | | | | | | | | | | | | | | |
| | x _ _ _ | | 0h | | | | | | | | | | | | | | | | | | | | | | | | | | | | | | | | | | | | | |
| Table 5.8 Analog monitor setting value <table border="1" style="margin: auto;"> <thead> <tr> <th>Setting value</th> <th>Item</th> </tr> </thead> <tbody> <tr><td>00</td><td>Servo motor speed (±8 V/max. speed)</td></tr> <tr><td>01</td><td>Torque (±8 V/max. torque) (Note 2)</td></tr> <tr><td>02</td><td>Servo motor speed (+8 V/max. speed)</td></tr> <tr><td>03</td><td>Torque (+8 V/max. torque) (Note 2)</td></tr> <tr><td>04</td><td>Current command (±8 V/max. current command)</td></tr> <tr><td>05</td><td>The command pulse frequency (±10 V/4 Mpps)</td></tr> <tr><td>06</td><td>Servo motor-side droop pulses (±10 V/100 pulses) (Note 1)</td></tr> <tr><td>07</td><td>Servo motor-side droop pulses (±10 V/1000 pulses) (Note 1)</td></tr> <tr><td>08</td><td>Servo motor-side droop pulses (±10 V/10000 pulses) (Note 1)</td></tr> <tr><td>09</td><td>Servo motor-side droop pulses (±10 V/100000 pulses) (Note 1)</td></tr> <tr><td>0A</td><td>Feedback position (±10 V/1 Mpulses) (Note 1)</td></tr> <tr><td>0B</td><td>Feedback position (±10 V/10 Mpulses) (Note 1)</td></tr> <tr><td>0C</td><td>Feedback position (±10 V/100 Mpulses) (Note 1)</td></tr> <tr><td>0D</td><td>Bus voltage (+8 V/400 V)</td></tr> <tr><td>0E</td><td>Speed command 2 (±8 V/max. speed)</td></tr> <tr><td>17</td><td>Encoder inside temperature (±10 V/±128 °C)</td></tr> </tbody> </table> <p>Note 1. Encoder pulse unit. 2. 8 V is outputted at the maximum torque. However, when [Pr. PA11] and [Pr. PA12] are set to limit torque, 8 V is outputted at the torque highly limited.</p> | | | | | | | Setting value | Item | 00 | Servo motor speed (±8 V/max. speed) | 01 | Torque (±8 V/max. torque) (Note 2) | 02 | Servo motor speed (+8 V/max. speed) | 03 | Torque (+8 V/max. torque) (Note 2) | 04 | Current command (±8 V/max. current command) | 05 | The command pulse frequency (±10 V/4 Mpps) | 06 | Servo motor-side droop pulses (±10 V/100 pulses) (Note 1) | 07 | Servo motor-side droop pulses (±10 V/1000 pulses) (Note 1) | 08 | Servo motor-side droop pulses (±10 V/10000 pulses) (Note 1) | 09 | Servo motor-side droop pulses (±10 V/100000 pulses) (Note 1) | 0A | Feedback position (±10 V/1 Mpulses) (Note 1) | 0B | Feedback position (±10 V/10 Mpulses) (Note 1) | 0C | Feedback position (±10 V/100 Mpulses) (Note 1) | 0D | Bus voltage (+8 V/400 V) | 0E | Speed command 2 (±8 V/max. speed) | 17 | Encoder inside temperature (±10 V/±128 °C) |
| Setting value | Item | | | | | | | | | | | | | | | | | | | | | | | | | | | | | | | | | | | | | | | |
| 00 | Servo motor speed (±8 V/max. speed) | | | | | | | | | | | | | | | | | | | | | | | | | | | | | | | | | | | | | | | |
| 01 | Torque (±8 V/max. torque) (Note 2) | | | | | | | | | | | | | | | | | | | | | | | | | | | | | | | | | | | | | | | |
| 02 | Servo motor speed (+8 V/max. speed) | | | | | | | | | | | | | | | | | | | | | | | | | | | | | | | | | | | | | | | |
| 03 | Torque (+8 V/max. torque) (Note 2) | | | | | | | | | | | | | | | | | | | | | | | | | | | | | | | | | | | | | | | |
| 04 | Current command (±8 V/max. current command) | | | | | | | | | | | | | | | | | | | | | | | | | | | | | | | | | | | | | | | |
| 05 | The command pulse frequency (±10 V/4 Mpps) | | | | | | | | | | | | | | | | | | | | | | | | | | | | | | | | | | | | | | | |
| 06 | Servo motor-side droop pulses (±10 V/100 pulses) (Note 1) | | | | | | | | | | | | | | | | | | | | | | | | | | | | | | | | | | | | | | | |
| 07 | Servo motor-side droop pulses (±10 V/1000 pulses) (Note 1) | | | | | | | | | | | | | | | | | | | | | | | | | | | | | | | | | | | | | | | |
| 08 | Servo motor-side droop pulses (±10 V/10000 pulses) (Note 1) | | | | | | | | | | | | | | | | | | | | | | | | | | | | | | | | | | | | | | | |
| 09 | Servo motor-side droop pulses (±10 V/100000 pulses) (Note 1) | | | | | | | | | | | | | | | | | | | | | | | | | | | | | | | | | | | | | | | |
| 0A | Feedback position (±10 V/1 Mpulses) (Note 1) | | | | | | | | | | | | | | | | | | | | | | | | | | | | | | | | | | | | | | | |
| 0B | Feedback position (±10 V/10 Mpulses) (Note 1) | | | | | | | | | | | | | | | | | | | | | | | | | | | | | | | | | | | | | | | |
| 0C | Feedback position (±10 V/100 Mpulses) (Note 1) | | | | | | | | | | | | | | | | | | | | | | | | | | | | | | | | | | | | | | | |
| 0D | Bus voltage (+8 V/400 V) | | | | | | | | | | | | | | | | | | | | | | | | | | | | | | | | | | | | | | | |
| 0E | Speed command 2 (±8 V/max. speed) | | | | | | | | | | | | | | | | | | | | | | | | | | | | | | | | | | | | | | | |
| 17 | Encoder inside temperature (±10 V/±128 °C) | | | | | | | | | | | | | | | | | | | | | | | | | | | | | | | | | | | | | | | |
| PC15 MOD2 Analog monitor 2 output | __ x x | Analog monitor 2 output selection Used to selection the signal provided to MO2 (Analog monitor 2) output. Refer to app. 10 (3) for detection point of output selection. Refer to [Pr. PC14] for settings. | 01h | ○ | ○ | ○ | | | | | | | | | | | | | | | | | | | | | | | | | | | | | | | | | | |
| | _ x _ _ | For manufacturer setting | 0h | | | | | | | | | | | | | | | | | | | | | | | | | | | | | | | | | | | | | |
| | x _ _ _ | | 0h | | | | | | | | | | | | | | | | | | | | | | | | | | | | | | | | | | | | | |
| PC16 MBR Electromagnetic brake sequence output | | This is used to set the delay time between MBR (Electromagnetic brake interlock) and the base drive circuit is shut-off. Setting range: 0 to 1000 | 0 [ms] | ○ | ○ | ○ | | | | | | | | | | | | | | | | | | | | | | | | | | | | | | | | | | |
| PC17 ZSP Zero speed | | Used to set the output range of ZSP (Zero speed detection). ZSP (Zero speed detection) has hysteresis of 20 r/min. Setting range: 0 to 10000 | 50 [r/min] | ○ | ○ | ○ | | | | | | | | | | | | | | | | | | | | | | | | | | | | | | | | | | |

5. PARAMETERS

| No./symbol/name | Setting digit | Function | Initial value [unit] | Control mode | | | | | | | | | | | | | |
|---|---|--|--------------------------|--------------------------------|--------------------------|--------------------------|----|---|--|--|---|--|--|----|-----------------------|-----------------------|-----------------------|
| | | | | P | S | T | | | | | | | | | | | |
| PC18 *BPS Alarm history clear | ___x | Alarm history clear selection Used to clear the alarm history. 0: Disabled 1: Enabled When you select "Enabled", the alarm history will be cleared at next power-on. After the alarm history is cleared, the setting is automatically disabled. | 0h | <input type="radio"/> | <input type="radio"/> | <input type="radio"/> | | | | | | | | | | | |
| | __x_ | For manufacturer setting | 0h | <input type="checkbox"/> | <input type="checkbox"/> | <input type="checkbox"/> | | | | | | | | | | | |
| | _x__ | | 0h | <input type="checkbox"/> | <input type="checkbox"/> | <input type="checkbox"/> | | | | | | | | | | | |
| | x___ | | 0h | <input type="checkbox"/> | <input type="checkbox"/> | <input type="checkbox"/> | | | | | | | | | | | |
| PC19 *ENRS Encoder output pulse selection | ___x | Encoder output pulse phase selection Select the encoder pulse direction. 0: Increasing A-phase 90° in CCW 1: Increasing A-phase 90° in CW <table border="1" style="margin: 10px auto;"> <thead> <tr> <th rowspan="2">Setting value</th> <th colspan="2">Servo motor rotation direction</th> </tr> <tr> <th>CCW</th> <th>CW</th> </tr> </thead> <tbody> <tr> <td>0</td> <td> </td> <td> </td> </tr> <tr> <td>1</td> <td> </td> <td> </td> </tr> </tbody> </table> | Setting value | Servo motor rotation direction | | CCW | CW | 0 | | | 1 | | | 0h | <input type="radio"/> | <input type="radio"/> | <input type="radio"/> |
| | Setting value | Servo motor rotation direction | | | | | | | | | | | | | | | |
| | | CCW | CW | | | | | | | | | | | | | | |
| | 0 | | | | | | | | | | | | | | | | |
| 1 | | | | | | | | | | | | | | | | | |
| __x_ | Encoder output pulse setting selection 0: Output pulse setting 1: Division ratio setting 2: The same output pulse setting as command pulse 3: A/B-phase pulse electronic gear setting When you select "2", the settings of [Pr. PA15 Encoder output pulses] and [Pr. PA16 Encoder output pulses 2] will be disabled. | 0h | <input type="radio"/> | <input type="radio"/> | <input type="radio"/> | | | | | | | | | | | | |
| _x__ | For manufacturer setting | 0h | <input type="checkbox"/> | <input type="checkbox"/> | <input type="checkbox"/> | | | | | | | | | | | | |
| x___ | | 0h | <input type="checkbox"/> | <input type="checkbox"/> | <input type="checkbox"/> | | | | | | | | | | | | |
| PC20 *SNO Station number setting | <input type="checkbox"/> | This is used to specify the station number of the servo amplifier. Always set one station to one axis of the servo amplifier. Setting one station number to two or more stations will disable a normal communication. Setting range: 0 to 31 | 0 [Station] | <input type="radio"/> | <input type="radio"/> | <input type="radio"/> | | | | | | | | | | | |
| PC22 *COP1 Function selection C-1 | ___x | For manufacturer setting | 0h | <input type="checkbox"/> | <input type="checkbox"/> | <input type="checkbox"/> | | | | | | | | | | | |
| | __x_ | | 0h | <input type="checkbox"/> | <input type="checkbox"/> | <input type="checkbox"/> | | | | | | | | | | | |
| | _x__ | | 0h | <input type="checkbox"/> | <input type="checkbox"/> | <input type="checkbox"/> | | | | | | | | | | | |
| | x___ | Encoder cable communication method selection Select the encoder cable communication method. 0: Two-wire type 1: Four-wire type Incorrect setting will result in [AL. 16 Encoder initial communication error 1]. | 0h | <input type="radio"/> | <input type="radio"/> | <input type="radio"/> | | | | | | | | | | | |

5. PARAMETERS

| No./symbol/name | Setting digit | Function | Initial value [unit] | Control mode | | | | | | | | | | | | | | | |
|---|---------------------|---|----------------------|---------------------|---|---|---|-------|---|-------|---|-------|---|-------|---|-------|--|--|--|
| | | | | P | S | T | | | | | | | | | | | | | |
| PC23 *COP2 Function selection C-2 | ___x | Servo-lock selection at speed control stop Select the servo-lock selection at speed control stop. In the speed control mode, the servo motor shaft can be locked to prevent the shaft from being moved by an outer force. 0: Enabled (servo-lock) The operation to maintain the stop position is performed. 1: Disabled (no servo-lock) The stop position is not maintained. The control to make the speed 0 r/min is performed. | 0h | | ○ | | | | | | | | | | | | | | |
| | __x_ | For manufacturer setting | 0h | | | | | | | | | | | | | | | | |
| | _x__ | VC/VLA voltage averaging selection Select the VC/VLA voltage average. This is used to set the filtering time when VC (Analog speed command) or VLA (Analog speed limit) is imported. Set 0 to vary the speed to voltage fluctuation in real time. Increase the set value to vary the speed slower to voltage fluctuation. | 0h | | ○ | ○ | | | | | | | | | | | | | |
| | | <table border="1"> <thead> <tr> <th>Setting value</th> <th>Filtering time [ms]</th> </tr> </thead> <tbody> <tr> <td>0</td> <td>0</td> </tr> <tr> <td>1</td> <td>0.444</td> </tr> <tr> <td>2</td> <td>0.888</td> </tr> <tr> <td>3</td> <td>1.777</td> </tr> <tr> <td>4</td> <td>3.555</td> </tr> <tr> <td>5</td> <td>7.111</td> </tr> </tbody> </table> | Setting value | Filtering time [ms] | 0 | 0 | 1 | 0.444 | 2 | 0.888 | 3 | 1.777 | 4 | 3.555 | 5 | 7.111 | | | |
| Setting value | Filtering time [ms] | | | | | | | | | | | | | | | | | | |
| 0 | 0 | | | | | | | | | | | | | | | | | | |
| 1 | 0.444 | | | | | | | | | | | | | | | | | | |
| 2 | 0.888 | | | | | | | | | | | | | | | | | | |
| 3 | 1.777 | | | | | | | | | | | | | | | | | | |
| 4 | 3.555 | | | | | | | | | | | | | | | | | | |
| 5 | 7.111 | | | | | | | | | | | | | | | | | | |
| | x___ | Speed limit selection at torque control Select the speed limit selection at torque control. 0: Enabled 1: Disabled Do not use this function except when configuring a external speed loop. | 0h | | | ○ | | | | | | | | | | | | | |
| PC24 *COP3 Function selection C-3 | ___x | In-position range unit selection Select a unit of in-position range. 0: Command input pulse unit 1: Servo motor encoder pulse unit | 0h | ○ | | | | | | | | | | | | | | | |
| | __x_ | For manufacturer setting | 0h | | | | | | | | | | | | | | | | |
| | _x__ | | 0h | | | | | | | | | | | | | | | | |
| | x___ | Error excessive alarm level unit selection Select a setting unit of the error excessive alarm level set in [Pr. PC43]. 0: 1 rev unit 1: 0.1 rev unit 2: 0.01 rev unit 3: 0.001 rev unit | 0h | ○ | | | | | | | | | | | | | | | |
| PC26 *COP5 Function selection C-5 | ___x | [AL. 99 Stroke limit warning] selection Select [AL. 99 Stroke limit warning]. 0: Enabled 1: Disabled | 0h | ○ | ○ | | | | | | | | | | | | | | |
| | __x_ | For manufacturer setting | 0h | | | | | | | | | | | | | | | | |
| | _x__ | | 0h | | | | | | | | | | | | | | | | |
| | x___ | | 0h | | | | | | | | | | | | | | | | |
| PC27 *COP6 Function selection C-6 | ___x | Undervoltage alarm detection method selection When you use FR-RC, FR-CV, or FR-BU2, select "Method 2 (___1)". 0: Method 1 1: Method 2 | 0h | ○ | ○ | ○ | | | | | | | | | | | | | |
| | __x_ | For manufacturer setting | 0h | | | | | | | | | | | | | | | | |
| | _x__ | | 0h | | | | | | | | | | | | | | | | |
| | x___ | | 0h | | | | | | | | | | | | | | | | |

5. PARAMETERS

| No./symbol/name | Setting digit | Function | Initial value [unit] | Control mode | | |
|--|---------------|--|----------------------|-----------------------|-----------------------|-----------------------|
| | | | | P | S | T |
| PC30 STA2 Acceleration time constant 2 | | To enable the parameter, turn on STAB2 (Speed acceleration/deceleration selection). This is used to set the acceleration time required to reach the rated speed from 0 r/min in response to VC (Analog speed command) and [Pr. PC05 Internal speed command 1] to [Pr. PC11 Internal speed command 7]. Setting range: 0 to 50000 | 0 [ms] | | <input type="radio"/> | <input type="radio"/> |
| PC31 STB2 Deceleration time constant 2 | | To enable the parameter, turn on STAB2 (Speed acceleration/deceleration selection). This is used to set the deceleration time required to reach the rated speed from 0 r/min in response to VC (Analog speed command) and [Pr. PC05 Internal speed command 1] to [Pr. PC11 Internal speed command 7]. Setting range: 0 to 50000 | 0 [ms] | | <input type="radio"/> | <input type="radio"/> |
| PC32 CMX2 Commanded pulse multiplication numerator 2 | | To enable the parameter, select "Electronic gear (0 ___)" or "J3A electronic gear setting value compatibility mode (2 ___)" of "Electronic gear selection" in [Pr. PA21]. Setting range: 0 to 16777215 | 1 | <input type="radio"/> | | |
| PC33 CMX3 Commanded pulse multiplication numerator 3 | | To enable the parameter, select "Electronic gear (0 ___)" or "J3A electronic gear setting value compatibility mode (2 ___)" of "Electronic gear selection" in [Pr. PA21]. Setting range: 0 to 16777215 | 1 | <input type="radio"/> | | |
| PC34 CMX4 Commanded pulse multiplication numerator 4 | | To enable the parameter, select "Electronic gear (0 ___)" or "J3A electronic gear setting value compatibility mode (2 ___)" of "Electronic gear selection" in [Pr. PA21]. Setting range: 0 to 16777215 | 1 | <input type="radio"/> | | |
| PC35 TL2 Internal torque limit 2 | | Set the parameter on the assumption that the maximum torque is 100 %. The parameter is for limiting the torque of the servo motor. Set this parameter to "0.0" to generate no torque. When you output torque with analog monitor output, the value will be the maximum output voltage (+8 V). (Refer to section 3.6.1 (5).) Setting range: 0.0 to 100.0 | 100.0 [%] | <input type="radio"/> | <input type="radio"/> | <input type="radio"/> |

5. PARAMETERS

| No./symbol/name | Setting digit | Function | Initial value [unit] | Control mode | | | | | | | | | | | | | | | | |
|--|--|---|----------------------|----------------------------|--------------------------|----------------------------|----------------|--|-------|-------------------|--------------|---|--------|-------------------------------|-----------------|--|----|-----------------------|-----------------------|-----------------------|
| | | | | P | S | T | | | | | | | | | | | | | | |
| PC36 *DMD Status display selection | __ x x | Status display selection at power-on This is used to select a status display shown at power-on. 00: Cumulative feedback pulse 01: Servo motor speed 02: Droop pulses 03: Cumulative command pulses 04: Command pulse frequency 05: Analog speed command voltage (Note 1) 06: Analog torque command voltage (Note 2) 07: Regenerative load ratio 08: Effective load ratio 09: Peak load ratio 0A: Instantaneous torque 0B: Within one-revolution position (1 pulse unit) 0C: Within one-revolution position (100 pulses unit) 0D: ABS counter 0E: Load to motor inertia ratio 0F: Bus voltage 10: Encoder inside temperature 11: Settling time 12: Oscillation detection frequency 13: Number of tough drive operations 14: Unit power consumption 15: Unit power consumption (increment of 1 kW) 16: Unit total power consumption (increment of 1 kWh) 17: Unit total power consumption (increment of 100 kWh) Note 1. It is for the speed control mode. It will be the analog speed limit voltage in the torque control mode. 2. It is for the torque control mode. It will be the analog torque limit voltage in the speed control mode and position control mode. | 00h | <input type="radio"/> | <input type="radio"/> | <input type="radio"/> | | | | | | | | | | | | | | |
| | _ x _ _ | Status display at power-on in corresponding control mode 0: Depends on the control mode <table border="1" style="margin-left: 20px;"> <thead> <tr> <th>Control mode</th> <th>Status display at power-on</th> </tr> </thead> <tbody> <tr> <td>Position</td> <td>Cumulative feedback pulses</td> </tr> <tr> <td>Position/speed</td> <td>Cumulative feedback pulses/servo motor speed</td> </tr> <tr> <td>Speed</td> <td>Servo motor speed</td> </tr> <tr> <td>Speed/torque</td> <td>Servo motor speed/analog torque command voltage</td> </tr> <tr> <td>Torque</td> <td>Analog torque command voltage</td> </tr> <tr> <td>Torque/position</td> <td>Analog torque command voltage/cumulative feedback pulses</td> </tr> </tbody> </table> 1: Depends on the first digit setting of the parameter | Control mode | Status display at power-on | Position | Cumulative feedback pulses | Position/speed | Cumulative feedback pulses/servo motor speed | Speed | Servo motor speed | Speed/torque | Servo motor speed/analog torque command voltage | Torque | Analog torque command voltage | Torque/position | Analog torque command voltage/cumulative feedback pulses | 0h | <input type="radio"/> | <input type="radio"/> | <input type="radio"/> |
| | Control mode | Status display at power-on | | | | | | | | | | | | | | | | | | |
| Position | Cumulative feedback pulses | | | | | | | | | | | | | | | | | | | |
| Position/speed | Cumulative feedback pulses/servo motor speed | | | | | | | | | | | | | | | | | | | |
| Speed | Servo motor speed | | | | | | | | | | | | | | | | | | | |
| Speed/torque | Servo motor speed/analog torque command voltage | | | | | | | | | | | | | | | | | | | |
| Torque | Analog torque command voltage | | | | | | | | | | | | | | | | | | | |
| Torque/position | Analog torque command voltage/cumulative feedback pulses | | | | | | | | | | | | | | | | | | | |
| x _ _ _ | For manufacturer setting | | 0h | <input type="checkbox"/> | <input type="checkbox"/> | <input type="checkbox"/> | | | | | | | | | | | | | | |

5. PARAMETERS

| No./symbol/name | Setting digit | Function | Initial value [unit] | Control mode | | |
|--|---------------|---|----------------------|--------------|---|---|
| | | | | P | S | T |
| PC37 VCO Analog speed command offset/Analog speed limit offset | | <p>This is used to set the offset voltage of VC (Analog speed command). For example, if CCW rotation is provided by switching on ST1 (Forward rotation start) with applying 0 V to VC, set a negative value. When automatic VC offset is used, the automatically offset value is set to this parameter. (Refer to section 4.5.4) The initial value is provided before shipment by the automatic VC offset function on condition that the voltage between VC and LG is 0 V.</p> <p>Setting range: -9999 to 9999</p> | 0 [mV] | | ○ | |
| | | <p>This is used to set the offset voltage of VLA (Analog speed limit). For example, if CCW rotation is provided by switching on RS1 (Forward rotation selection) with applying 0 V to VLA, set a negative value. When automatic VC offset is used, the automatically offset value is set to this parameter. (Refer to section 4.5.4) The initial value is provided before shipment by the automatic VC offset function on condition that the voltage between VLA and LG is 0 V.</p> <p>Setting range: -9999 to 9999</p> | | | | |
| PC38 TPO Analog torque command offset/Analog torque limit offset | | <p>This is used to set the offset voltage of TC (Analog torque command).</p> <p>Setting range: -9999 to 9999</p> | 0 [mV] | | | ○ |
| | | <p>This is used to set the offset voltage of TLA (Analog torque limit).</p> <p>Setting range: -9999 to 9999</p> | | | | |
| PC39 MO1 Analog monitor 1 offset | | <p>This is used to set the offset voltage of MO1 (Analog monitor 1).</p> <p>Setting range: -9999 to 9999</p> | 0 [mV] | ○ | ○ | ○ |
| PC40 MO2 Analog monitor 2 offset | | <p>This is used to set the offset voltage of MO2 (Analog monitor 2).</p> <p>Setting range: -9999 to 9999</p> | 0 [mV] | ○ | ○ | ○ |
| PC43 ERZ Error excessive alarm level | | <p>Set an error excessive alarm level. You can change the setting unit with "Error excessive alarm level" in [Pr. PC24]. However, setting "0" will be 3 rev. Setting range: 0 to 1000</p> | 0 [rev] | ○ | | |

5. PARAMETERS

| No./symbol/name | Setting digit | Function | Initial value [unit] | Control mode | | |
|--|---------------|--|----------------------|-----------------------|-----------------------|---|
| | | | | P | S | T |
| PC51 RSBR Forced stop deceleration time constant | | <p>This is used to set deceleration time constant when you use the forced stop deceleration function. Set the time per ms from the rated speed to 0 r/min.</p> <p>[Precautions]</p> <ul style="list-style-type: none"> • If the servo motor torque is saturated at the maximum torque during forced stop deceleration because the set time is too short, the time to stop will be longer than the set time constant. • [AL. 50 Overload alarm 1] or [AL. 51 Overload alarm 2] may occur during forced stop deceleration, depending on the set value. • After an alarm that leads to a forced stop deceleration, if an alarm that does not lead to a forced stop deceleration occurs or if the control circuit power supply is cut, dynamic braking will start regardless of the deceleration time constant setting. <p>Setting range: 0 to 20000</p> | 100 [ms] | <input type="radio"/> | <input type="radio"/> | |
| PC54 RSUP1 Vertical axis freefall prevention compensation amount | | <p>Set the compensation amount of the vertical axis freefall prevention function. Set it per servo motor rotation amount.</p> <p>The function will pull up an shaft per rotation amount to the servo motor rotation direction at the time of inputting forward rotation pulse for a positive number, and at the time of inputting reverse rotation pulse for a negative number.</p> <p>For example, if a positive compensation amount is set when the [Pr. PA14 Rotation direction selection] setting is "1", compensation will be performed to the CW direction.</p> <p>The vertical axis freefall prevention function is performed when all of the following conditions are met.</p> <ol style="list-style-type: none"> 1) Position control mode 2) The value of the parameter is other than "0". 3) The forced stop deceleration function is enabled. 4) Alarm occurs or EM2 turns off when the servo motor speed is zero speed or less. 5) MBR (Electromagnetic brake interlock) was enabled in [Pr. PD23] to [Pr. PD28], and the base circuit shut-off delay time was set in [Pr. PC16]. <p>Setting range: -25000 to 25000</p> | 0 [0.0001 rev] | <input type="radio"/> | | |
| PC60 *COPD Function selection C-D | ___ x | <p>Motor-less operation selection This is used to select the motor-less operation.</p> <p>0: Disabled 1: Enabled</p> | 0h | | | |
| | __ x _ | For manufacturer setting | 0h | | | |
| | _ x _ _ | | 0h | | | |
| | x _ _ _ | | 0h | | | |

5. PARAMETERS

5.2.4 I/O setting parameters ([Pr. PD_ _])

| No./symbol/name | Setting digit | Function | Initial value [unit] | Control mode | | |
|--|---|--|----------------------|--------------|---|---|
| | | | | P | S | T |
| PD01 *DIA1 Input signal automatic on selection 1 | Select input devices to turn on them automatically. | | | | | |
| | ___x (HEX) | ___x (BIN): For manufacturer setting | 0h | | | |
| | | __x_ (BIN): For manufacturer setting | | | | |
| | | _x__ (BIN): SON (Servo-on) | | ○ | ○ | ○ |
| | | 0: Disabled (Use for an external input signal.) 1: Enabled (automatic on) | | | | |
| | _x_ (HEX) | x___ (BIN): For manufacturer setting | 0h | | | |
| | | ___x (BIN): PC (Proportional control) | | ○ | ○ | |
| | | 0: Disabled (Use for an external input signal.) 1: Enabled (automatic on) | | | | |
| | | __x_ (BIN): TL (External torque limit selection) | | ○ | ○ | |
| | _x__ (HEX) | _x__ (BIN): For manufacturer setting | 0h | | | |
| | | __x_ (BIN): For manufacturer setting | | | | |
| | | _x__ (BIN): LSP (Forward rotation stroke end) | | ○ | ○ | |
| | | 0: Disabled (Use for an external input signal.) 1: Enabled (automatic on) | | | | |
| | x___ | x___ (BIN): LSN (Reverse rotation stroke end) | 0h | ○ | ○ | |
| | | 0: Disabled (Use for an external input signal.) 1: Enabled (automatic on) | | | | |
| x___ | For manufacturer setting | 0h | | | | |

5. PARAMETERS

| No./symbol/name | Setting digit | Function | Initial value [unit] | Control mode | | | | | | | | | | | | | | | | | | | | | | | | | | | | | | | | | | | | | | | | | | | | | | | | | | | | | | | | | | | | | | | | | | | | | | | | | | | | | | | | | |
|---|--|--|----------------------|--------------|---|---|---------------|---------------------|--|--|---|---|---|----|-----|-----|-----|----|-----|-----|-----|----|----|----|---|----|----|----|---|----|----|---|---|----|---|-----|-----|----|---|-----|-----|----|-----|-----|---|----|-----|-----|---|----|-----|-----|---|----|-----|-----|---|----|---|-----|-----|----|---|-----|-----|----|---|-----|-----|----|-----|-----|-----|----|-----|---|---|----|-----|---|---|----|---|-------|-------|
| | | | | P | S | T | | | | | | | | | | | | | | | | | | | | | | | | | | | | | | | | | | | | | | | | | | | | | | | | | | | | | | | | | | | | | | | | | | | | | | | | | | | | | | | |
| PD03 *DI1L Input device selection 1L | Any input device can be assigned to the CN1-15 pin. | | | | | | | | | | | | | | | | | | | | | | | | | | | | | | | | | | | | | | | | | | | | | | | | | | | | | | | | | | | | | | | | | | | | | | | | | | | | | | | | | | | | |
| | __ x x | Position control mode - Device selection Refer to table 5.9 in [Pr. PD03] for settings. | 02h | ○ | / | / | | | | | | | | | | | | | | | | | | | | | | | | | | | | | | | | | | | | | | | | | | | | | | | | | | | | | | | | | | | | | | | | | | | | | | | | | | | | | | | |
| | x x __ | Speed control mode - Device selection Refer to table 5.9 in [Pr. PD03] for settings. | 02h | / | ○ | / | | | | | | | | | | | | | | | | | | | | | | | | | | | | | | | | | | | | | | | | | | | | | | | | | | | | | | | | | | | | | | | | | | | | | | | | | | | | | | | |
| Table 5.9 Selectable input devices | | | | | | | | | | | | | | | | | | | | | | | | | | | | | | | | | | | | | | | | | | | | | | | | | | | | | | | | | | | | | | | | | | | | | | | | | | | | | | | | | | | | | |
| <table border="1" style="width: 100%; border-collapse: collapse;"> <thead> <tr> <th rowspan="2">Setting value</th> <th colspan="3">Input device (Note)</th> </tr> <tr> <th>P</th> <th>S</th> <th>T</th> </tr> </thead> <tbody> <tr><td>02</td><td>SON</td><td>SON</td><td>SON</td></tr> <tr><td>03</td><td>RES</td><td>RES</td><td>RES</td></tr> <tr><td>04</td><td>PC</td><td>PC</td><td>/</td></tr> <tr><td>05</td><td>TL</td><td>TL</td><td>/</td></tr> <tr><td>06</td><td>CR</td><td>/</td><td>/</td></tr> <tr><td>07</td><td>/</td><td>ST1</td><td>RS2</td></tr> <tr><td>08</td><td>/</td><td>ST2</td><td>RS1</td></tr> <tr><td>09</td><td>TL1</td><td>TL1</td><td>/</td></tr> <tr><td>0A</td><td>LSP</td><td>LSP</td><td>/</td></tr> <tr><td>0B</td><td>LSN</td><td>LSN</td><td>/</td></tr> <tr><td>0D</td><td>CDP</td><td>CDP</td><td>/</td></tr> <tr><td>20</td><td>/</td><td>SP1</td><td>SP1</td></tr> <tr><td>21</td><td>/</td><td>SP2</td><td>SP2</td></tr> <tr><td>22</td><td>/</td><td>SP3</td><td>SP3</td></tr> <tr><td>23</td><td>LOP</td><td>LOP</td><td>LOP</td></tr> <tr><td>24</td><td>CM1</td><td>/</td><td>/</td></tr> <tr><td>25</td><td>CM2</td><td>/</td><td>/</td></tr> <tr><td>26</td><td>/</td><td>STAB2</td><td>STAB2</td></tr> </tbody> </table> <p style="text-align: center;">Note. P: position control mode, S: speed control mode, T: torque control mode The diagonal lines indicate manufacturer settings. Never change the setting.</p> | | | | | | | Setting value | Input device (Note) | | | P | S | T | 02 | SON | SON | SON | 03 | RES | RES | RES | 04 | PC | PC | / | 05 | TL | TL | / | 06 | CR | / | / | 07 | / | ST1 | RS2 | 08 | / | ST2 | RS1 | 09 | TL1 | TL1 | / | 0A | LSP | LSP | / | 0B | LSN | LSN | / | 0D | CDP | CDP | / | 20 | / | SP1 | SP1 | 21 | / | SP2 | SP2 | 22 | / | SP3 | SP3 | 23 | LOP | LOP | LOP | 24 | CM1 | / | / | 25 | CM2 | / | / | 26 | / | STAB2 | STAB2 |
| Setting value | Input device (Note) | | | | | | | | | | | | | | | | | | | | | | | | | | | | | | | | | | | | | | | | | | | | | | | | | | | | | | | | | | | | | | | | | | | | | | | | | | | | | | | | | | | | |
| | P | S | T | | | | | | | | | | | | | | | | | | | | | | | | | | | | | | | | | | | | | | | | | | | | | | | | | | | | | | | | | | | | | | | | | | | | | | | | | | | | | | | | | | |
| 02 | SON | SON | SON | | | | | | | | | | | | | | | | | | | | | | | | | | | | | | | | | | | | | | | | | | | | | | | | | | | | | | | | | | | | | | | | | | | | | | | | | | | | | | | | | | |
| 03 | RES | RES | RES | | | | | | | | | | | | | | | | | | | | | | | | | | | | | | | | | | | | | | | | | | | | | | | | | | | | | | | | | | | | | | | | | | | | | | | | | | | | | | | | | | |
| 04 | PC | PC | / | | | | | | | | | | | | | | | | | | | | | | | | | | | | | | | | | | | | | | | | | | | | | | | | | | | | | | | | | | | | | | | | | | | | | | | | | | | | | | | | | | |
| 05 | TL | TL | / | | | | | | | | | | | | | | | | | | | | | | | | | | | | | | | | | | | | | | | | | | | | | | | | | | | | | | | | | | | | | | | | | | | | | | | | | | | | | | | | | | |
| 06 | CR | / | / | | | | | | | | | | | | | | | | | | | | | | | | | | | | | | | | | | | | | | | | | | | | | | | | | | | | | | | | | | | | | | | | | | | | | | | | | | | | | | | | | | |
| 07 | / | ST1 | RS2 | | | | | | | | | | | | | | | | | | | | | | | | | | | | | | | | | | | | | | | | | | | | | | | | | | | | | | | | | | | | | | | | | | | | | | | | | | | | | | | | | | |
| 08 | / | ST2 | RS1 | | | | | | | | | | | | | | | | | | | | | | | | | | | | | | | | | | | | | | | | | | | | | | | | | | | | | | | | | | | | | | | | | | | | | | | | | | | | | | | | | | |
| 09 | TL1 | TL1 | / | | | | | | | | | | | | | | | | | | | | | | | | | | | | | | | | | | | | | | | | | | | | | | | | | | | | | | | | | | | | | | | | | | | | | | | | | | | | | | | | | | |
| 0A | LSP | LSP | / | | | | | | | | | | | | | | | | | | | | | | | | | | | | | | | | | | | | | | | | | | | | | | | | | | | | | | | | | | | | | | | | | | | | | | | | | | | | | | | | | | |
| 0B | LSN | LSN | / | | | | | | | | | | | | | | | | | | | | | | | | | | | | | | | | | | | | | | | | | | | | | | | | | | | | | | | | | | | | | | | | | | | | | | | | | | | | | | | | | | |
| 0D | CDP | CDP | / | | | | | | | | | | | | | | | | | | | | | | | | | | | | | | | | | | | | | | | | | | | | | | | | | | | | | | | | | | | | | | | | | | | | | | | | | | | | | | | | | | |
| 20 | / | SP1 | SP1 | | | | | | | | | | | | | | | | | | | | | | | | | | | | | | | | | | | | | | | | | | | | | | | | | | | | | | | | | | | | | | | | | | | | | | | | | | | | | | | | | | |
| 21 | / | SP2 | SP2 | | | | | | | | | | | | | | | | | | | | | | | | | | | | | | | | | | | | | | | | | | | | | | | | | | | | | | | | | | | | | | | | | | | | | | | | | | | | | | | | | | |
| 22 | / | SP3 | SP3 | | | | | | | | | | | | | | | | | | | | | | | | | | | | | | | | | | | | | | | | | | | | | | | | | | | | | | | | | | | | | | | | | | | | | | | | | | | | | | | | | | |
| 23 | LOP | LOP | LOP | | | | | | | | | | | | | | | | | | | | | | | | | | | | | | | | | | | | | | | | | | | | | | | | | | | | | | | | | | | | | | | | | | | | | | | | | | | | | | | | | | |
| 24 | CM1 | / | / | | | | | | | | | | | | | | | | | | | | | | | | | | | | | | | | | | | | | | | | | | | | | | | | | | | | | | | | | | | | | | | | | | | | | | | | | | | | | | | | | | |
| 25 | CM2 | / | / | | | | | | | | | | | | | | | | | | | | | | | | | | | | | | | | | | | | | | | | | | | | | | | | | | | | | | | | | | | | | | | | | | | | | | | | | | | | | | | | | | |
| 26 | / | STAB2 | STAB2 | | | | | | | | | | | | | | | | | | | | | | | | | | | | | | | | | | | | | | | | | | | | | | | | | | | | | | | | | | | | | | | | | | | | | | | | | | | | | | | | | | |
| PD04 *DI1H Input device selection 1H | Any input device can be assigned to the CN1-15 pin. | | | | | | | | | | | | | | | | | | | | | | | | | | | | | | | | | | | | | | | | | | | | | | | | | | | | | | | | | | | | | | | | | | | | | | | | | | | | | | | | | | | | |
| | __ x x | Torque control mode - Device selection Refer to table 5.9 in [Pr. PD03] for settings. | 02h | / | / | ○ | | | | | | | | | | | | | | | | | | | | | | | | | | | | | | | | | | | | | | | | | | | | | | | | | | | | | | | | | | | | | | | | | | | | | | | | | | | | | | | |
| | __ x __ | For manufacturer setting | 0h | / | / | / | | | | | | | | | | | | | | | | | | | | | | | | | | | | | | | | | | | | | | | | | | | | | | | | | | | | | | | | | | | | | | | | | | | | | | | | | | | | | | | |
| | x __ __ | | 0h | / | / | / | | | | | | | | | | | | | | | | | | | | | | | | | | | | | | | | | | | | | | | | | | | | | | | | | | | | | | | | | | | | | | | | | | | | | | | | | | | | | | | |
| PD05 *DI2L Input device selection 2L | Any input device can be assigned to the CN1-16 pin. | | | | | | | | | | | | | | | | | | | | | | | | | | | | | | | | | | | | | | | | | | | | | | | | | | | | | | | | | | | | | | | | | | | | | | | | | | | | | | | | | | | | |
| | __ x x | Position control mode - Device selection Refer to table 5.9 in [Pr. PD03] for settings. | 00h | ○ | / | / | | | | | | | | | | | | | | | | | | | | | | | | | | | | | | | | | | | | | | | | | | | | | | | | | | | | | | | | | | | | | | | | | | | | | | | | | | | | | | | |
| | x x __ | Speed control mode - Device selection Refer to table 5.9 for settings. | 21h | / | ○ | / | | | | | | | | | | | | | | | | | | | | | | | | | | | | | | | | | | | | | | | | | | | | | | | | | | | | | | | | | | | | | | | | | | | | | | | | | | | | | | | |
| PD06 *DI2H Input device selection 2H | Any input device can be assigned to the CN1-16 pin. | | | | | | | | | | | | | | | | | | | | | | | | | | | | | | | | | | | | | | | | | | | | | | | | | | | | | | | | | | | | | | | | | | | | | | | | | | | | | | | | | | | | |
| | __ x x | Torque control mode - Device selection Refer to table 5.9 in [Pr. PD03] for settings. | 21h | / | / | ○ | | | | | | | | | | | | | | | | | | | | | | | | | | | | | | | | | | | | | | | | | | | | | | | | | | | | | | | | | | | | | | | | | | | | | | | | | | | | | | | |
| | __ x __ | For manufacturer setting | 0h | / | / | / | | | | | | | | | | | | | | | | | | | | | | | | | | | | | | | | | | | | | | | | | | | | | | | | | | | | | | | | | | | | | | | | | | | | | | | | | | | | | | | |
| | x __ __ | | 0h | / | / | / | | | | | | | | | | | | | | | | | | | | | | | | | | | | | | | | | | | | | | | | | | | | | | | | | | | | | | | | | | | | | | | | | | | | | | | | | | | | | | | |
| PD07 *DI3L Input device selection 3L | Any input device can be assigned to the CN1-17 pin. When "___ 1" is set in [Pr. PA03] and absolute position detection system by DIO is selected, CN1-17 pin will become ABSM (ABS transfer mode). | | | | | | | | | | | | | | | | | | | | | | | | | | | | | | | | | | | | | | | | | | | | | | | | | | | | | | | | | | | | | | | | | | | | | | | | | | | | | | | | | | | | |
| | __ x x | Position control mode - Device selection Refer to table 5.9 in [Pr. PD03] for settings. | 04h | ○ | / | / | | | | | | | | | | | | | | | | | | | | | | | | | | | | | | | | | | | | | | | | | | | | | | | | | | | | | | | | | | | | | | | | | | | | | | | | | | | | | | | |
| | x x __ | Speed control mode - Device selection Refer to table 5.9 in [Pr. PD03] for settings. | 07h | / | ○ | / | | | | | | | | | | | | | | | | | | | | | | | | | | | | | | | | | | | | | | | | | | | | | | | | | | | | | | | | | | | | | | | | | | | | | | | | | | | | | | | |

5. PARAMETERS

| No./symbol/name | Setting digit | Function | Initial value [unit] | Control mode | | |
|--|---|--|----------------------|--------------------------|--------------------------|--------------------------|
| | | | | P | S | T |
| PD08 *DI3H Input device selection 3H | Any input device can be assigned to the CN1-17 pin. | | | | | |
| | __ x x | Torque control mode - Device selection Refer to table 5.9 in [Pr. PD03] for settings. | 07h | <input type="checkbox"/> | <input type="checkbox"/> | <input type="checkbox"/> |
| | _ x __ | For manufacturer setting | 0h | <input type="checkbox"/> | <input type="checkbox"/> | <input type="checkbox"/> |
| | x ___ | | 0h | <input type="checkbox"/> | <input type="checkbox"/> | <input type="checkbox"/> |
| PD09 *DI4L Input device selection 4L | Any input device can be assigned to the CN1-18 pin. When "___ 1" is set in [Pr. PA03] and absolute position detection system by DIO is selected, CN1-18 pin will become ABSR (ABS transfer request). | | | | | |
| | __ x x | Position control mode - Device selection Refer to table 5.9 in [Pr. PD03] for settings. | 05h | <input type="checkbox"/> | <input type="checkbox"/> | <input type="checkbox"/> |
| | x x __ | Speed control mode - Device selection Refer to table 5.9 in [Pr. PD03] for settings. | 08h | <input type="checkbox"/> | <input type="checkbox"/> | <input type="checkbox"/> |
| PD10 *DI4H Input device selection 4H | Any input device can be assigned to the CN1-18 pin. | | | | | |
| | __ x x | Torque control mode - Device selection Refer to table 5.9 in [Pr. PD03] for settings. | 08h | <input type="checkbox"/> | <input type="checkbox"/> | <input type="checkbox"/> |
| | _ x __ | For manufacturer setting | 0h | <input type="checkbox"/> | <input type="checkbox"/> | <input type="checkbox"/> |
| | x ___ | | 0h | <input type="checkbox"/> | <input type="checkbox"/> | <input type="checkbox"/> |
| PD11 *DI5L Input device selection 5L | Any input device can be assigned to the CN1-19 pin. | | | | | |
| | __ x x | Position control mode - Device selection Refer to table 5.9 in [Pr. PD03] for settings. | 03h | <input type="checkbox"/> | <input type="checkbox"/> | <input type="checkbox"/> |
| | x x __ | Speed control mode - Device selection Refer to table 5.9 in [Pr. PD03] for settings. | 03h | <input type="checkbox"/> | <input type="checkbox"/> | <input type="checkbox"/> |
| PD12 *DI5H Input device selection 5H | Any input device can be assigned to the CN1-19 pin. | | | | | |
| | __ x x | Torque control mode - Device selection Refer to table 5.9 in [Pr. PD03] for settings. | 03h | <input type="checkbox"/> | <input type="checkbox"/> | <input type="checkbox"/> |
| | _ x __ | For manufacturer setting | 0h | <input type="checkbox"/> | <input type="checkbox"/> | <input type="checkbox"/> |
| | x ___ | | 0h | <input type="checkbox"/> | <input type="checkbox"/> | <input type="checkbox"/> |
| PD13 *DI6L Input device selection 6L | Any input device can be assigned to the CN1-41 pin. | | | | | |
| | __ x x | Position control mode - Device selection Refer to table 5.9 in [Pr. PD03] for settings. | 06h | <input type="checkbox"/> | <input type="checkbox"/> | <input type="checkbox"/> |
| | x x __ | Speed control mode - Device selection Refer to table 5.9 in [Pr. PD03] for settings. | 20h | <input type="checkbox"/> | <input type="checkbox"/> | <input type="checkbox"/> |
| PD14 *DI6H Input device selection 6H | Any input device can be assigned to the CN1-41 pin. | | | | | |
| | __ x x | Torque control mode - Device selection Refer to table 5.9 in [Pr. PD03] for settings. | 20h | <input type="checkbox"/> | <input type="checkbox"/> | <input type="checkbox"/> |
| | _ x __ | For manufacturer setting | 0h | <input type="checkbox"/> | <input type="checkbox"/> | <input type="checkbox"/> |
| | x ___ | | 0h | <input type="checkbox"/> | <input type="checkbox"/> | <input type="checkbox"/> |
| PD17 *DI8L Input device selection 8L | Any input device can be assigned to the CN1-43 pin. | | | | | |
| | __ x x | Position control mode - Device selection Refer to table 5.9 in [Pr. PD03] for settings. | 0Ah | <input type="checkbox"/> | <input type="checkbox"/> | <input type="checkbox"/> |
| | x x __ | Speed control mode - Device selection Refer to table 5.9 in [Pr. PD03] for settings. | 0Ah | <input type="checkbox"/> | <input type="checkbox"/> | <input type="checkbox"/> |
| PD18 *DI8H Input device selection 8H | Any input device can be assigned to the CN1-43 pin. | | | | | |
| | __ x x | Torque control mode - Device selection Refer to table 5.9 in [Pr. PD03] for settings. | 00h | <input type="checkbox"/> | <input type="checkbox"/> | <input type="checkbox"/> |
| | _ x __ | For manufacturer setting | 0h | <input type="checkbox"/> | <input type="checkbox"/> | <input type="checkbox"/> |
| | x ___ | | 0h | <input type="checkbox"/> | <input type="checkbox"/> | <input type="checkbox"/> |
| PD19 *DI9L Input device selection 9L | Any input device can be assigned to the CN1-44 pin. | | | | | |
| | __ x x | Position control mode - Device selection Refer to table 5.9 in [Pr. PD03] for settings. | 0Bh | <input type="checkbox"/> | <input type="checkbox"/> | <input type="checkbox"/> |
| | x x __ | Speed control mode - Device selection Refer to table 5.9 in [Pr. PD03] for settings. | 0Bh | <input type="checkbox"/> | <input type="checkbox"/> | <input type="checkbox"/> |

5. PARAMETERS

| No./symbol/name | Setting digit | Function | Initial value [unit] | Control mode | | | | | | | | | | | | | | | | | | | | | | | | | | | | | | | | | | | | | | | | | | | | | | | | | | | | | | | | | | | | | | | | |
|--|---|--|----------------------|--------------|---|---|---------------|----------------------|--|--|---|---|---|----|------------|------------|------------|----|----|----|----|----|-----|-----|-----|----|-----|----|------------|----|-----|-----|-----|----|-----|-----|-----|----|-----|-----|-----|----|------|------|------|----|------------|----|------------|----|------------|------------|-----|----|-----|-----|-----|----|------|------|------|----|------|------------|------------|----|------|------------|
| | | | | P | S | T | | | | | | | | | | | | | | | | | | | | | | | | | | | | | | | | | | | | | | | | | | | | | | | | | | | | | | | | | | | | | | |
| PD20 *DI9H Input device selection 9H | Any input device can be assigned to the CN1-44 pin. | | | | | | | | | | | | | | | | | | | | | | | | | | | | | | | | | | | | | | | | | | | | | | | | | | | | | | | | | | | | | | | | | | | |
| | __ x x | Torque control mode - Device selection Refer to table 5.9 in [Pr. PD03] for settings. | 00h | | | ○ | | | | | | | | | | | | | | | | | | | | | | | | | | | | | | | | | | | | | | | | | | | | | | | | | | | | | | | | | | | | | | |
| | _ x _ _ x _ _ _ | For manufacturer setting | 0h 0h | | | | | | | | | | | | | | | | | | | | | | | | | | | | | | | | | | | | | | | | | | | | | | | | | | | | | | | | | | | | | | | | | |
| PD21 *DI10L Input device selection 10L | Any input device can be assigned to the CN1-45 pin. | | | | | | | | | | | | | | | | | | | | | | | | | | | | | | | | | | | | | | | | | | | | | | | | | | | | | | | | | | | | | | | | | | | |
| | __ x x x x _ _ | Position control mode - Device selection Refer to table 5.9 in [Pr. PD03] for settings. Speed control mode - Device selection Refer to table 5.9 in [Pr. PD03] for settings. | 23h 23h | ○ | | | | | | | | | | | | | | | | | | | | | | | | | | | | | | | | | | | | | | | | | | | | | | | | | | | | | | | | | | | | | | | | |
| PD22 *DI10H Input device selection 10H | Any input device can be assigned to the CN1-45 pin. | | | | | | | | | | | | | | | | | | | | | | | | | | | | | | | | | | | | | | | | | | | | | | | | | | | | | | | | | | | | | | | | | | | |
| | __ x x | Torque control mode - Device selection Refer to table 5.9 in [Pr. PD03] for settings. | 23h | | | ○ | | | | | | | | | | | | | | | | | | | | | | | | | | | | | | | | | | | | | | | | | | | | | | | | | | | | | | | | | | | | | | |
| | _ x _ _ x _ _ _ | For manufacturer setting | 0h 0h | | | | | | | | | | | | | | | | | | | | | | | | | | | | | | | | | | | | | | | | | | | | | | | | | | | | | | | | | | | | | | | | | |
| PD23 *DO1 Output device selection 1 | __ x x | Device selection Any output device can be assigned to the CN1-22 pin. When "Enabled (absolute position detection system by DIO) (_ _ _ 1)" is selected in [Pr. PA03], CN1-22 pin will become ABSB0 (ABS send data bit 0) only during ABS transfer mode. Refer to table 5.10 in [Pr. PD23] for settings. | 04h | ○ | ○ | ○ | | | | | | | | | | | | | | | | | | | | | | | | | | | | | | | | | | | | | | | | | | | | | | | | | | | | | | | | | | | | | | |
| | _ x _ _ x _ _ _ | For manufacturer setting | 0h 0h | | | | | | | | | | | | | | | | | | | | | | | | | | | | | | | | | | | | | | | | | | | | | | | | | | | | | | | | | | | | | | | | | |
| | Table 5.10 Selectable output devices <table border="1" style="margin: auto;"> <thead> <tr> <th rowspan="2">Setting value</th> <th colspan="3">Output device (Note)</th> </tr> <tr> <th>P</th> <th>S</th> <th>T</th> </tr> </thead> <tbody> <tr><td>00</td><td>Always off</td><td>Always off</td><td>Always off</td></tr> <tr><td>02</td><td>RD</td><td>RD</td><td>RD</td></tr> <tr><td>03</td><td>ALM</td><td>ALM</td><td>ALM</td></tr> <tr><td>04</td><td>INP</td><td>SA</td><td>Always off</td></tr> <tr><td>05</td><td>MBR</td><td>MBR</td><td>MBR</td></tr> <tr><td>07</td><td>TLC</td><td>TLC</td><td>VLC</td></tr> <tr><td>08</td><td>WNG</td><td>WNG</td><td>WNG</td></tr> <tr><td>09</td><td>BWNG</td><td>BWNG</td><td>BWNG</td></tr> <tr><td>0A</td><td>Always off</td><td>SA</td><td>Always off</td></tr> <tr><td>0B</td><td>Always off</td><td>Always off</td><td>VLC</td></tr> <tr><td>0C</td><td>ZSP</td><td>ZSP</td><td>ZSP</td></tr> <tr><td>0D</td><td>MTTR</td><td>MTTR</td><td>MTTR</td></tr> <tr><td>0F</td><td>CDPS</td><td>Always off</td><td>Always off</td></tr> <tr><td>11</td><td>ABSV</td><td>Always off</td><td>Always off</td></tr> </tbody> </table> <p>Note. P: position control mode, S: speed control mode, T: torque control mode</p> | | | | | | Setting value | Output device (Note) | | | P | S | T | 00 | Always off | Always off | Always off | 02 | RD | RD | RD | 03 | ALM | ALM | ALM | 04 | INP | SA | Always off | 05 | MBR | MBR | MBR | 07 | TLC | TLC | VLC | 08 | WNG | WNG | WNG | 09 | BWNG | BWNG | BWNG | 0A | Always off | SA | Always off | 0B | Always off | Always off | VLC | 0C | ZSP | ZSP | ZSP | 0D | MTTR | MTTR | MTTR | 0F | CDPS | Always off | Always off | 11 | ABSV | Always off |
| Setting value | Output device (Note) | | | | | | | | | | | | | | | | | | | | | | | | | | | | | | | | | | | | | | | | | | | | | | | | | | | | | | | | | | | | | | | | | | | |
| | P | S | T | | | | | | | | | | | | | | | | | | | | | | | | | | | | | | | | | | | | | | | | | | | | | | | | | | | | | | | | | | | | | | | | | |
| 00 | Always off | Always off | Always off | | | | | | | | | | | | | | | | | | | | | | | | | | | | | | | | | | | | | | | | | | | | | | | | | | | | | | | | | | | | | | | | | |
| 02 | RD | RD | RD | | | | | | | | | | | | | | | | | | | | | | | | | | | | | | | | | | | | | | | | | | | | | | | | | | | | | | | | | | | | | | | | | |
| 03 | ALM | ALM | ALM | | | | | | | | | | | | | | | | | | | | | | | | | | | | | | | | | | | | | | | | | | | | | | | | | | | | | | | | | | | | | | | | | |
| 04 | INP | SA | Always off | | | | | | | | | | | | | | | | | | | | | | | | | | | | | | | | | | | | | | | | | | | | | | | | | | | | | | | | | | | | | | | | | |
| 05 | MBR | MBR | MBR | | | | | | | | | | | | | | | | | | | | | | | | | | | | | | | | | | | | | | | | | | | | | | | | | | | | | | | | | | | | | | | | | |
| 07 | TLC | TLC | VLC | | | | | | | | | | | | | | | | | | | | | | | | | | | | | | | | | | | | | | | | | | | | | | | | | | | | | | | | | | | | | | | | | |
| 08 | WNG | WNG | WNG | | | | | | | | | | | | | | | | | | | | | | | | | | | | | | | | | | | | | | | | | | | | | | | | | | | | | | | | | | | | | | | | | |
| 09 | BWNG | BWNG | BWNG | | | | | | | | | | | | | | | | | | | | | | | | | | | | | | | | | | | | | | | | | | | | | | | | | | | | | | | | | | | | | | | | | |
| 0A | Always off | SA | Always off | | | | | | | | | | | | | | | | | | | | | | | | | | | | | | | | | | | | | | | | | | | | | | | | | | | | | | | | | | | | | | | | | |
| 0B | Always off | Always off | VLC | | | | | | | | | | | | | | | | | | | | | | | | | | | | | | | | | | | | | | | | | | | | | | | | | | | | | | | | | | | | | | | | | |
| 0C | ZSP | ZSP | ZSP | | | | | | | | | | | | | | | | | | | | | | | | | | | | | | | | | | | | | | | | | | | | | | | | | | | | | | | | | | | | | | | | | |
| 0D | MTTR | MTTR | MTTR | | | | | | | | | | | | | | | | | | | | | | | | | | | | | | | | | | | | | | | | | | | | | | | | | | | | | | | | | | | | | | | | | |
| 0F | CDPS | Always off | Always off | | | | | | | | | | | | | | | | | | | | | | | | | | | | | | | | | | | | | | | | | | | | | | | | | | | | | | | | | | | | | | | | | |
| 11 | ABSV | Always off | Always off | | | | | | | | | | | | | | | | | | | | | | | | | | | | | | | | | | | | | | | | | | | | | | | | | | | | | | | | | | | | | | | | | |
| PD24 *DO2 Output device selection 2 | __ x x | Device selection Any output device can be assigned to the CN1-23 pin. When "Enabled (absolute position detection system by DIO) (_ _ _ 1)" is selected in [Pr. PA03], CN1-23 pin will become ABSB1 (ABS send data bit 1) only during ABS transfer mode. Refer to table 5.10 in [Pr. PD23] for settings. | 0Ch | ○ | ○ | ○ | | | | | | | | | | | | | | | | | | | | | | | | | | | | | | | | | | | | | | | | | | | | | | | | | | | | | | | | | | | | | | |
| | _ x _ _ x _ _ _ | For manufacturer setting | 0h 0h | | | | | | | | | | | | | | | | | | | | | | | | | | | | | | | | | | | | | | | | | | | | | | | | | | | | | | | | | | | | | | | | | |

5. PARAMETERS

| No./symbol/name | Setting digit | Function | Initial value [unit] | Control mode | | |
|---|---------------------------------------|---|----------------------|--------------------------|--------------------------|--------------------------|
| | | | | P | S | T |
| PD25 *DO3 Output device selection 3 | __ x x | Device selection Any output device can be assigned to the CN1-24 pin. Refer to table 5.10 in [Pr. PD23] for settings. | 04h | <input type="radio"/> | <input type="radio"/> | <input type="radio"/> |
| | _ x _ _ | For manufacturer setting | 0h | <input type="checkbox"/> | <input type="checkbox"/> | <input type="checkbox"/> |
| | x _ _ _ | | 0h | <input type="checkbox"/> | <input type="checkbox"/> | <input type="checkbox"/> |
| PD26 *DO4 Output device selection 4 | __ x x | Device selection Any output device can be assigned to the CN1-25 pin. When "Enabled (absolute position detection system by DIO) (_ _ _ 1)" is selected in [Pr. PA03], CN1-25 pin will become ABST (ABS send data ready) only during ABS transfer mode. Refer to table 5.10 in [Pr. PD23] for settings. | 07h | <input type="radio"/> | <input type="radio"/> | <input type="radio"/> |
| | _ x _ _ | For manufacturer setting | 0h | <input type="checkbox"/> | <input type="checkbox"/> | <input type="checkbox"/> |
| | x _ _ _ | | 0h | <input type="checkbox"/> | <input type="checkbox"/> | <input type="checkbox"/> |
| PD28 *DO6 Output device selection 6 | __ x x | Device selection Any output device can be assigned to the CN1-49 pin. Refer to table 5.10 in [Pr. PD23] for settings. | 02h | <input type="radio"/> | <input type="radio"/> | <input type="radio"/> |
| | _ x _ _ | For manufacturer setting | 0h | <input type="checkbox"/> | <input type="checkbox"/> | <input type="checkbox"/> |
| | x _ _ _ | | 0h | <input type="checkbox"/> | <input type="checkbox"/> | <input type="checkbox"/> |
| PD29 *DIF Input filter setting | Select a filter for the input signal. | | | | | |
| | ___ x | Input signal filter selection If external input signal causes chattering due to noise, etc., input filter is used to suppress it. 0: None 1: 0.888 [ms] 2: 1.777 [ms] 3: 2.666 [ms] 4: 3.555 [ms] | 4h | <input type="radio"/> | <input type="radio"/> | <input type="radio"/> |
| | _ _ x _ | RES (Reset) dedicated filter selection 0: Disabled 1: Enabled (50 [ms]) | 0h | <input type="radio"/> | <input type="radio"/> | <input type="radio"/> |
| | _ x _ _ | CR (Clear) dedicated filter selection 0: Disabled 1: Enabled (50 [ms]) | 0h | <input type="radio"/> | <input type="radio"/> | <input type="radio"/> |
| PD30 *DOP1 Function selection D-1 | ___ x | Stop method selection for LSP (Forward rotation stroke end) off and LSN (Reverse rotation stroke end) off Select a stop method for LSP (Forward rotation stroke end) off and LSN (Reverse rotation stroke end) off 0: Quick stop 1: Slow stop | 0h | <input type="radio"/> | <input type="radio"/> | <input type="checkbox"/> |
| | _ _ x _ | Base circuit status selection for RES (Reset) on 0: Base circuit shut-off 1: No base circuit shut-off | 0h | <input type="radio"/> | <input type="radio"/> | <input type="radio"/> |
| | _ x _ _ | For manufacturer setting | 0h | <input type="checkbox"/> | <input type="checkbox"/> | <input type="checkbox"/> |
| | x _ _ _ | | 0h | <input type="checkbox"/> | <input type="checkbox"/> | <input type="checkbox"/> |
| PD32 *DOP3 Function selection D-3 | ___ x | CR (Clear) selection This is used to set CR (Clear). 0: Deleting droop pulses by turning on the device 1: Continuous deleting of droop pulses during the device on | 0h | <input type="radio"/> | <input type="checkbox"/> | <input type="checkbox"/> |
| | _ _ x _ | For manufacturer setting | 0h | <input type="checkbox"/> | <input type="checkbox"/> | <input type="checkbox"/> |
| | _ x _ _ | | 0h | <input type="checkbox"/> | <input type="checkbox"/> | <input type="checkbox"/> |
| | x _ _ _ | | 0h | <input type="checkbox"/> | <input type="checkbox"/> | <input type="checkbox"/> |

5. PARAMETERS

| No./symbol/name | Setting digit | Function | Initial value [unit] | Control mode | | | | | | | | | | | | | | | | | | | | | | | | | | | | | | |
|---|--------------------------|--|--------------------------|--------------------------|--------------------------|-----------------------|-------|---------|-------|--------|-------|-------|---------|-------|--|--|--------------------|---|--------|-------|---------|-------|--------|-------|-------|---------|-------|--|--|-----------------------------|----|-----------------------|-----------------------|-----------------------|
| | | | | P | S | T | | | | | | | | | | | | | | | | | | | | | | | | | | | | |
| PD34 *DOP5 Function selection D-5 | ___x | Alarm code output This is used to select if output alarm codes. Alarm codes are outputted to pins CN1-22, CN1-23, and CN1-24. 0: Disabled 1: Enabled Refer to "MELSERVO-J4 Servo Amplifier Instruction Manual (Troubleshooting)" for details of alarm codes. When "Enabled (absolute position detection system by DIO) (___1)" is selected in [Pr. PA03] and when MBR (Electromagnetic brake interlock) or ALM (Malfunction) is assigned to CN1-22 pin, CN1-23 pin, or CN1-24 pin, selecting alarm code output will generate [AL. Parameter error]. | 0h | <input type="radio"/> | <input type="radio"/> | <input type="radio"/> | | | | | | | | | | | | | | | | | | | | | | | | | | | | |
| | __x_ | Selection of output device at warning occurrence Select ALM (Malfunction) output status at warning occurrence. <table border="1" style="margin: 10px auto; width: 80%;"> <thead> <tr> <th>Setting value</th> <th>Device status</th> </tr> </thead> <tbody> <tr> <td rowspan="2">0</td> <td>WNG ON</td> <td>_____</td> </tr> <tr> <td>WNG OFF</td> <td>_____</td> </tr> <tr> <td rowspan="2">ALM ON</td> <td>_____</td> <td>_____</td> </tr> <tr> <td>ALM OFF</td> <td>_____</td> </tr> <tr> <td colspan="2"></td> <td style="text-align: center;">Warning occurrence</td> </tr> <tr> <td rowspan="2">1</td> <td>WNG ON</td> <td>_____</td> </tr> <tr> <td>WNG OFF</td> <td>_____</td> </tr> <tr> <td rowspan="2">ALM ON</td> <td>_____</td> <td>_____</td> </tr> <tr> <td>ALM OFF</td> <td>_____</td> </tr> <tr> <td colspan="2"></td> <td style="text-align: center;">Warning occurrence (Note 2)</td> </tr> </tbody> </table> | Setting value | Device status | 0 | WNG ON | _____ | WNG OFF | _____ | ALM ON | _____ | _____ | ALM OFF | _____ | | | Warning occurrence | 1 | WNG ON | _____ | WNG OFF | _____ | ALM ON | _____ | _____ | ALM OFF | _____ | | | Warning occurrence (Note 2) | 0h | <input type="radio"/> | <input type="radio"/> | <input type="radio"/> |
| | Setting value | Device status | | | | | | | | | | | | | | | | | | | | | | | | | | | | | | | | |
| | 0 | WNG ON | _____ | | | | | | | | | | | | | | | | | | | | | | | | | | | | | | | |
| WNG OFF | | _____ | | | | | | | | | | | | | | | | | | | | | | | | | | | | | | | | |
| ALM ON | _____ | _____ | | | | | | | | | | | | | | | | | | | | | | | | | | | | | | | | |
| | ALM OFF | _____ | | | | | | | | | | | | | | | | | | | | | | | | | | | | | | | | |
| | | Warning occurrence | | | | | | | | | | | | | | | | | | | | | | | | | | | | | | | | |
| 1 | WNG ON | _____ | | | | | | | | | | | | | | | | | | | | | | | | | | | | | | | | |
| | WNG OFF | _____ | | | | | | | | | | | | | | | | | | | | | | | | | | | | | | | | |
| ALM ON | _____ | _____ | | | | | | | | | | | | | | | | | | | | | | | | | | | | | | | | |
| | ALM OFF | _____ | | | | | | | | | | | | | | | | | | | | | | | | | | | | | | | | |
| | | Warning occurrence (Note 2) | | | | | | | | | | | | | | | | | | | | | | | | | | | | | | | | |
| _x__ | For manufacturer setting | 0h | <input type="checkbox"/> | <input type="checkbox"/> | <input type="checkbox"/> | | | | | | | | | | | | | | | | | | | | | | | | | | | | | |
| x___ | | 0h | <input type="checkbox"/> | <input type="checkbox"/> | <input type="checkbox"/> | | | | | | | | | | | | | | | | | | | | | | | | | | | | | |

5.2.5 Extension setting 2 parameters ([Pr. PE__])

| No./symbol/name | Setting digit | Function | Initial value [unit] | Control mode | | |
|--|---------------|---|----------------------|--------------------------|--------------------------|--------------------------|
| | | | | P | S | T |
| PE41 EOP3 Function selection E-3 | ___x | Robust filter selection 0: Disabled 1: Enabled When you select "Enabled" of this digit, the machine resonance suppression filter 5 set in [Pr. PB51] is not available. | 0h | <input type="radio"/> | <input type="radio"/> | <input type="radio"/> |
| | __x_ | For manufacturer setting | 0h | <input type="checkbox"/> | <input type="checkbox"/> | <input type="checkbox"/> |
| | _x__ | | 0h | <input type="checkbox"/> | <input type="checkbox"/> | <input type="checkbox"/> |
| | x___ | | 0h | <input type="checkbox"/> | <input type="checkbox"/> | <input type="checkbox"/> |

5. PARAMETERS

5.2.6 Extension setting 3 parameters ([Pr. PF__])

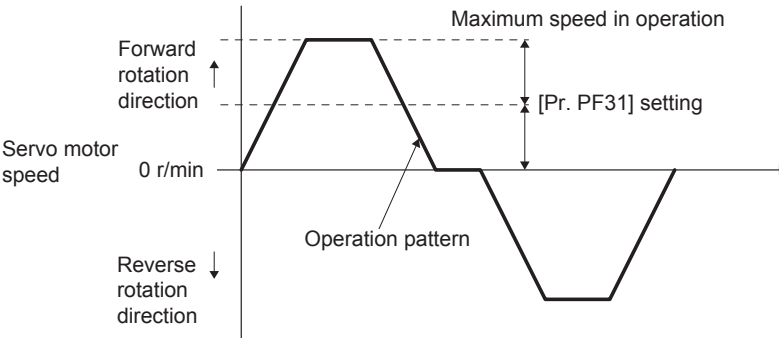
| No./symbol/name | Setting digit | Function | Initial value [unit] | Control mode | | |
|--|---------------|---|----------------------|--------------------------|--------------------------|--------------------------|
| | | | | P | S | T |
| PF21 DRT Drive recorder switching time setting | | This is used to set a drive recorder switching time. When a USB communication is cut during using a graph function, the function will be changed to the drive recorder function after the setting time of this parameter. When a value from "1" to "32767" is set, it will switch after the setting value. However, when "0" is set, it will switch after 600 seconds. When "-1" is set, the drive recorder function is disabled. Setting range: -1 to 32767 | 0 [s] | <input type="radio"/> | <input type="radio"/> | <input type="radio"/> |
| PF23 OSCL1 Vibration tough drive - Oscillation detection level | | This is used to set a filter readjustment sensitivity of [Pr. PB13 Machine resonance suppression filter 1] and [Pr. PB15 Machine resonance suppression filter 2] while the vibration tough drive is enabled. Example: When you set "50" to the parameter, the filter will be readjusted at the time of 50% or more oscillation level. Setting range: 0 to 100 | 50 [%] | <input type="radio"/> | <input type="radio"/> | <input type="radio"/> |
| PF24 *OSCL2 Vibration tough drive function selection | ___x | Oscillation detection alarm selection Select alarm or warning when an oscillation continues at a filter readjustment sensitivity level of [Pr. PF23]. The digit is continuously enabled regardless of the vibration tough drive in [Pr. PA20]. 0: [AL. 54 Oscillation detection] will occur at oscillation detection. 1: [AL. F3.1 Oscillation detection warning] will occur at oscillation detection. 2: Oscillation detection setting function disabled | 0h | <input type="radio"/> | <input type="radio"/> | <input type="radio"/> |
| | __x_ | For manufacturer setting | 0h | <input type="checkbox"/> | <input type="checkbox"/> | <input type="checkbox"/> |
| | _x__ | | 0h | <input type="checkbox"/> | <input type="checkbox"/> | <input type="checkbox"/> |
| | x___ | | 0h | <input type="checkbox"/> | <input type="checkbox"/> | <input type="checkbox"/> |
| PF25 CVAT Instantaneous power failure tough drive - Detection time | | Set the time of the [AL. 10.1 Voltage drop in the control power] occurrence. To disable the parameter, select "Disabled (_0_)" of "Instantaneous power failure tough drive selection" in [Pr. PA20]. Setting range: 30 to 200 | 200 [ms] | <input type="radio"/> | <input type="radio"/> | <input type="radio"/> |
| PF31 FRIC Machine diagnosis function - Friction judgement speed | | Set a motor speed to divide a friction estimation area into high and low for the friction estimation process of the machine diagnosis. However, setting "0" will be the value half of the rated speed. When your operation pattern is under rated speed, we recommend that you set half value to the maximum speed with this.  | 0 [r/min] | <input type="radio"/> | <input type="radio"/> | <input type="radio"/> |
| Setting range: 0 to permissible speed | | | | | | |

6. NORMAL GAIN ADJUSTMENT

6. NORMAL GAIN ADJUSTMENT

| POINT |
|--|
| <ul style="list-style-type: none"> ● In the torque control mode, you do not need to make gain adjustment. ● Before making gain adjustment, check that your machine is not being operated at maximum torque of the servo motor. If operated over maximum torque, the machine may vibrate and may operate unexpectedly. In addition, make gain adjustment with a safety margin considering characteristic differences of each machine. It is recommended that generated torque during operation is under 90% of the maximum torque of the servo motor. |

6.1 Different adjustment methods

6.1.1 Adjustment on a single servo amplifier

The following table shows the gain adjustment modes that can be set on a single servo amplifier. For gain adjustment, first execute "Auto tuning mode 1". If you are not satisfied with the result of the adjustment, execute "Auto tuning mode 2" and "Manual mode" in this order.

(1) Gain adjustment mode explanation

| Gain adjustment mode | [Pr. PA08] setting | Estimation of load to motor inertia ratio | Automatically set parameters | Manually set parameters |
|------------------------------------|--------------------|---|--|--|
| Auto tuning mode 1 (initial value) | 0 0 0 1 | Always estimated | GD2 ([Pr. PB06]) PG1 ([Pr. PB07]) PG2 ([Pr. PB08]) VG2 ([Pr. PB09]) VIC ([Pr. PB10]) | RSP ([Pr. PA09]) |
| Auto tuning mode 2 | 0 0 0 2 | Fixed to [Pr. PB06] value | PG1 ([Pr. PB07]) PG2 ([Pr. PB08]) VG2 ([Pr. PB09]) VIC ([Pr. PB10]) | GD2 ([Pr. PB06]) RSP ([Pr. PA09]) |
| Manual mode | 0 0 0 3 | | / | GD2 ([Pr. PB06]) PG1 ([Pr. PB07]) PG2 ([Pr. PB08]) VG2 ([Pr. PB09]) VIC ([Pr. PB10]) |
| 2 gain mode 1 (interpolation mode) | 0 0 0 0 | Always estimated | GD2 ([Pr. PB06]) PG2 ([Pr. PB08]) VG2 ([Pr. PB09]) VIC ([Pr. PB10]) | PG1 ([Pr. PB07]) RSP ([Pr. PA09]) |
| 2 gain adjustment mode 2 | 0 0 0 4 | Fixed to [Pr. PB06] value | PG2 ([Pr. PB08]) VG2 ([Pr. PB09]) VIC ([Pr. PB10]) | GD2 ([Pr. PB06]) PG1 ([Pr. PB07]) RSP ([Pr. PA09]) |

6. NORMAL GAIN ADJUSTMENT

(2) Adjustment sequence and mode usage

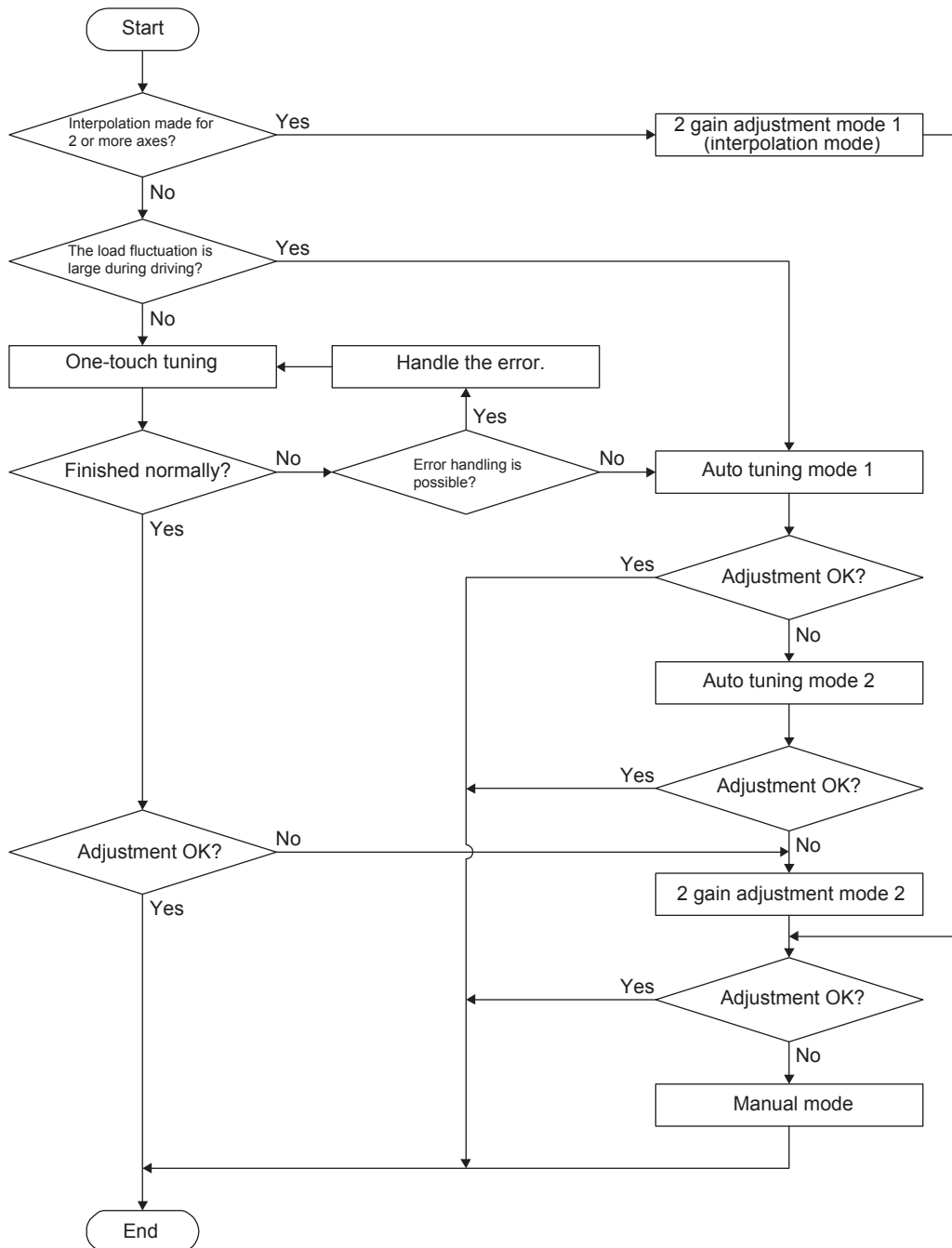

6.1.2 Adjustment using MR Configurator2

This section explains the functions and adjustment using the servo amplifier with MR Configurator2.

| Function | Description | Adjustment |
|------------------|--|--|
| Machine analyzer | With the machine and servo motor coupled, the characteristic of the mechanical system can be measured by giving a random vibration command from a personal computer to the servo and measuring the machine response. | You can grasp the machine resonance frequency and determine the notch frequency of the machine resonance suppression filter. |

6. NORMAL GAIN ADJUSTMENT

6.2 One-touch tuning

You can execute the one-touch tuning with MR Configurator2 or push buttons. The following parameters are set automatically with one-touch tuning.

Table 6.1 List of parameters automatically set with one-touch tuning

| Parameter | Symbol | Name | Parameter | Symbol | Name |
|-----------|--------|---|-----------|--------|---|
| PA08 | ATU | Auto tuning mode | PB16 | NHQ2 | Notch shape selection 2 |
| PA09 | RSP | Auto tuning response | PB18 | LPF | Low-pass filter setting |
| PB01 | FILT | Adaptive tuning mode (adaptive filter II) | PB19 | VRF11 | Vibration suppression control 1 - Vibration frequency |
| PB02 | VRFT | Vibration suppression control tuning mode (advanced vibration suppression control II) | PB20 | VRF12 | Vibration suppression control 1 - Resonance frequency |
| PB03 | PST | Position command acceleration/deceleration time constant (position smoothing) | PB21 | VRF13 | Vibration suppression control 1 - Vibration frequency dumping setting |
| PB06 | GD2 | Load to motor inertia ratio | PB22 | VRF14 | Vibration suppression control 1 - Resonance frequency dumping setting |
| PB07 | PG1 | Model loop gain | PB23 | VFBF | Low-pass filter selection |
| PB08 | PG2 | Position loop gain | PB47 | NHQ3 | Notch shape selection 3 |
| PB09 | VG2 | Speed loop gain | PB48 | NH4 | Machine resonance suppression filter 4 |
| PB10 | VIC | Speed integral compensation | PB49 | NHQ4 | Notch shape selection 4 |
| PB12 | OVA | Overshoot amount compensation | PB51 | NHQ5 | Notch shape selection 5 |
| PB13 | NH1 | Machine resonance suppression filter 1 | PE41 | EOP3 | Function selection E-3 |
| PB14 | NHQ1 | Notch shape selection 1 | | | |
| PB15 | NH2 | Machine resonance suppression filter 2 | | | |

6.2.1 One-touch tuning flowchart

- (1) When you use MR Configurator2
Make one-touch tuning as follows.

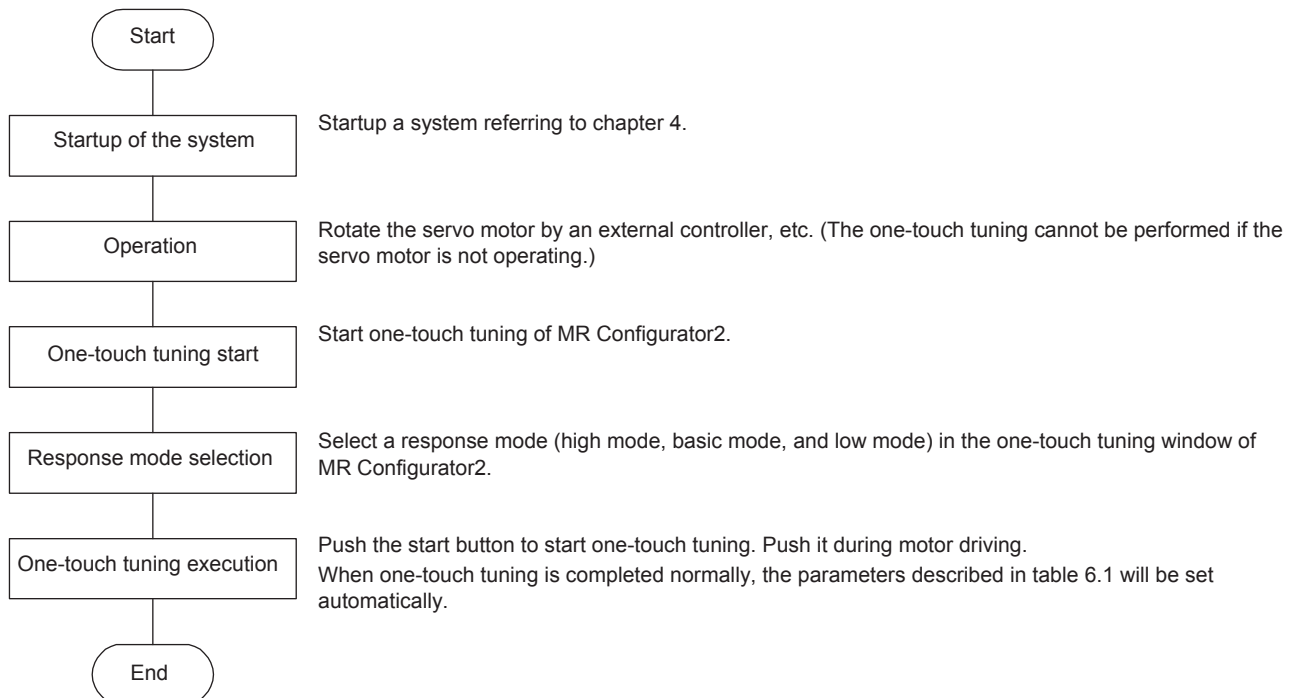

6. NORMAL GAIN ADJUSTMENT

- (2) When you use push buttons
Make one-touch tuning as follows.

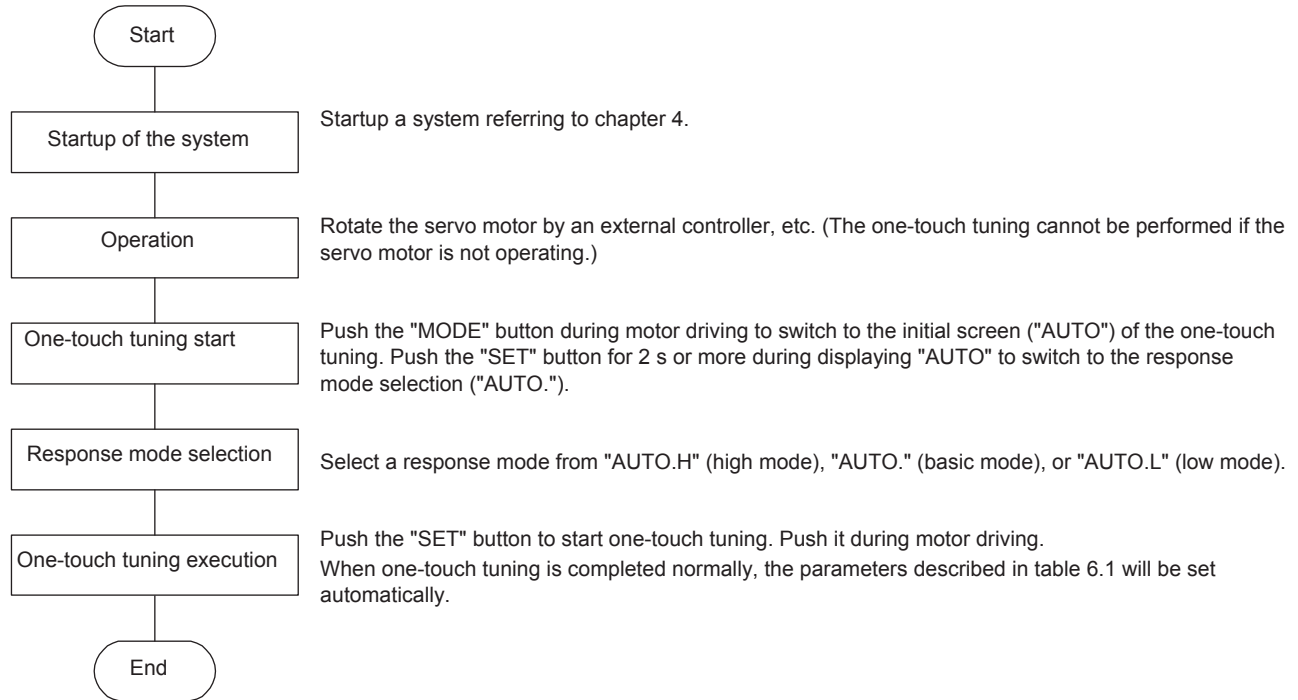

6. NORMAL GAIN ADJUSTMENT

6.2.2 Display transition and operation procedure of one-touch tuning

(1) When you use MR Configurator2

(a) Response mode selection

Select a response mode from 3 modes in the one-touch tuning window of MR Configurator2.

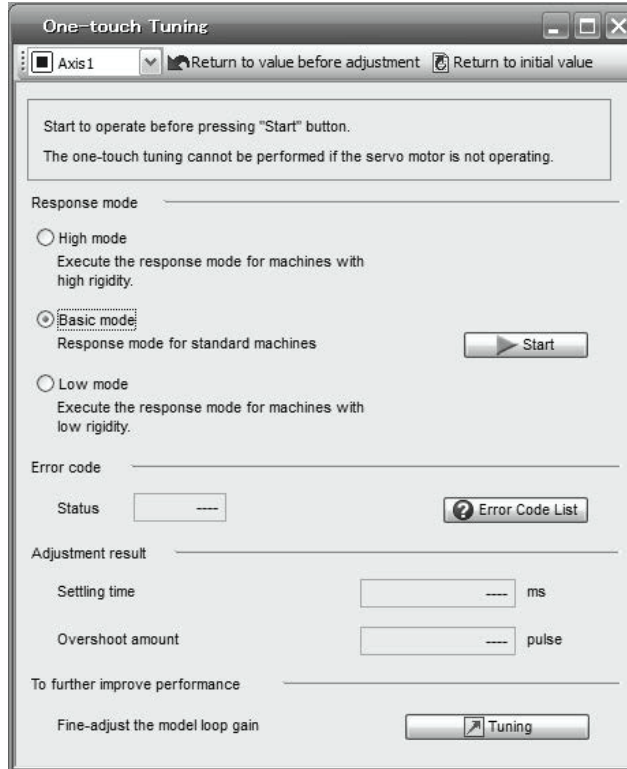

| Response mode | Explanation |
|---------------|-------------------------------------|
| High mode | This mode is for high rigid system. |
| Basic mode | This mode is for normal system. |
| Low mode | This mode is for low rigid system. |

Refer to the following table for selecting a response mode.

6. NORMAL GAIN ADJUSTMENT

| Response mode | | | Response | Machine characteristic |
|---------------|------------|-----------|---|---|
| Low mode | Basic mode | High mode | | Guideline of corresponding machine |
| ↑ ↓ | ↑ ↓ | ↑ ↓ | Low response ↑ ↓ High response | <p>Arm robot</p> <p>General machine tool conveyor</p> <p>Precision working machine</p> <p>Inserter Mounter Bonder</p> |

6. NORMAL GAIN ADJUSTMENT

(b) One-touch tuning execution

After the response mode is selected in (a), pushing the start button during driving will start one-touch tuning. If the start button is pushed while the motor stops, "C 0 0 2" or "C 0 0 4" will be displayed at status in error code. (Refer to table 6.2 of (1)(d) of this section for error codes.)

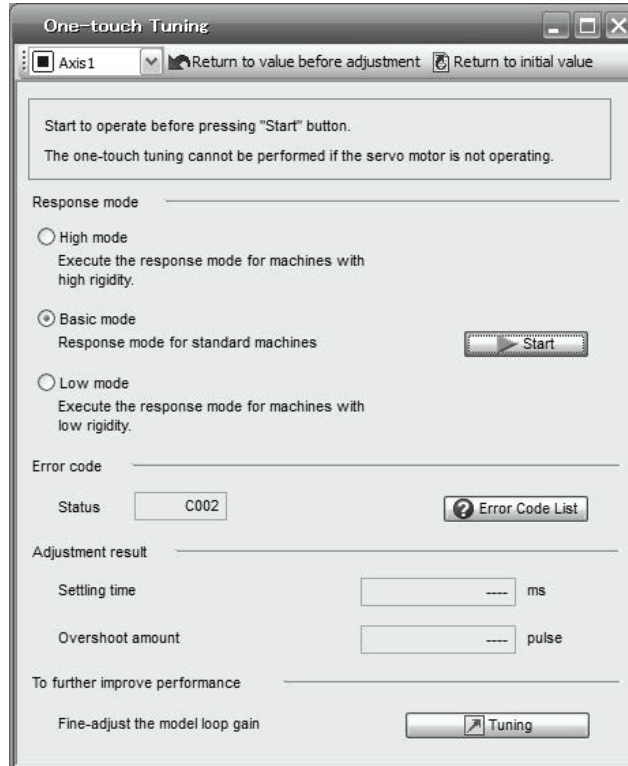

During processing of one-touch tuning, the status will be displayed in the progress window as follows. One-touch tuning will be finished at 100%.

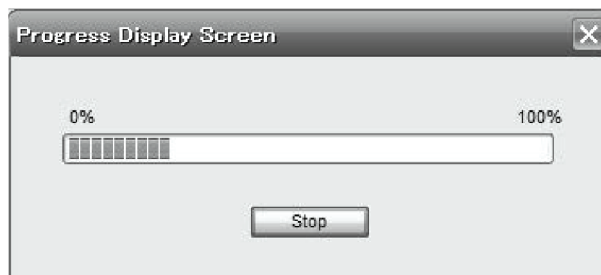

Completing the one-touch tuning starts writing tuning parameters to the servo amplifier. "0 0 0 0" is displayed at status in error code. In addition, settling time and overshoot amount will be displayed in "Adjustment result" after adjustment.

6. NORMAL GAIN ADJUSTMENT

(c) One-touch tuning execution

During one-touch tuning, pushing the stop button stops one-touch tuning.
If the one-touch tuning is stopped, "C 0 0 0" will be displayed at status in error code.

(d) If an error occur

If a tuning error occurs during tuning, one-touch tuning will be forcibly terminated. With that, the following error code will be displayed in status. Check the cause of adjustment error.

Table 6.2 List of error code with one-touch tuning

| Error code | Name | Description | Action |
|------------|--|---|---|
| C000 | Tuning canceled | The stop button or "SET" of the push button was pushed. | |
| C001 | Overshoot exceeded | The overshoot amount is larger than the value set in [Pr. PA10 In-position range]. | Increase the in-position range. |
| C002 | Servo-off during tuning | The one-touch tuning was attempted during servo-off. | Perform the one-touch tuning after servo-on. |
| C003 | Control mode error | The one-touch tuning was attempted while the torque control mode was selected in the control modes. | Select the position control mode or speed control mode for the control mode from the controller, and then make one-touch tuning. |
| C004 | Time-out | 1. 1 cycle time during the operation has been over 30 s. | Set the 1 cycle time during the operation to 30 s or less. |
| | | 2. The command speed is low. | Set the servo motor speed to 100 r/min or higher. |
| | | 3. The operation interval of the continuous operation is short. | Maintain the operation interval during motor driving about 200 ms. |
| C005 | Load to motor inertia ratio misestimated | 1. The estimation of the load to motor inertia ratio at one-touch tuning was a failure. | Drive the motor with meeting conditions as follows. <ul style="list-style-type: none"> Time to reach 2000 r/min is the acceleration/deceleration time constant of 5 s or less. Speed is 150 r/min or higher. The load to motor inertia ratio is 100 times or less. The acceleration/deceleration torque is 10% or more of the rated torque. |
| | | 2. The load to motor inertia ratio was not estimated due to such as an oscillation. | Set to the auto tuning mode that does not estimate the load to motor inertia ratio as follows, and then execute the one-touch tuning. <ul style="list-style-type: none"> Select "Auto tuning mode 2 (_ _ _ 2)", "Manual mode (_ _ _ 3)", or "2 gain adjustment mode 2 (_ _ _ 4)" of "Gain adjustment mode selection" in [Pr. PA08]. Set [Pr. PB06 Load to motor inertia ratio] properly with manual setting. |
| C00F | One-touch tuning disabled | "One-touch tuning function selection" in [Pr. PA21] is "Disabled (_ _ _ 0)" | Select "Enabled (_ _ _ 1)". |

(e) If an alarm occur

If an alarm occurs during tuning, one-touch tuning will be forcibly terminated.

(f) If a warning occur

If a warning which continue the motor driving occurs during the tuning, one-touch tuning will be continued.

If a warning which does not continue the motor driving occurs during the tuning, one-touch tuning will be stopped.

6. NORMAL GAIN ADJUSTMENT

(g) Clearing one-touch tuning

You can clear the parameter values set with one-touch tuning.

Refer to table 6.1 for the parameters which you can clear.

Pushing "Return to before tuning" in the one-touch tuning window of MR Configurator2 enables to rewrite the parameter to the value before pushing the start button.

In addition, pushing "Return to initial value" in the one-touch tuning window enables to rewrite the parameter to the initial value.

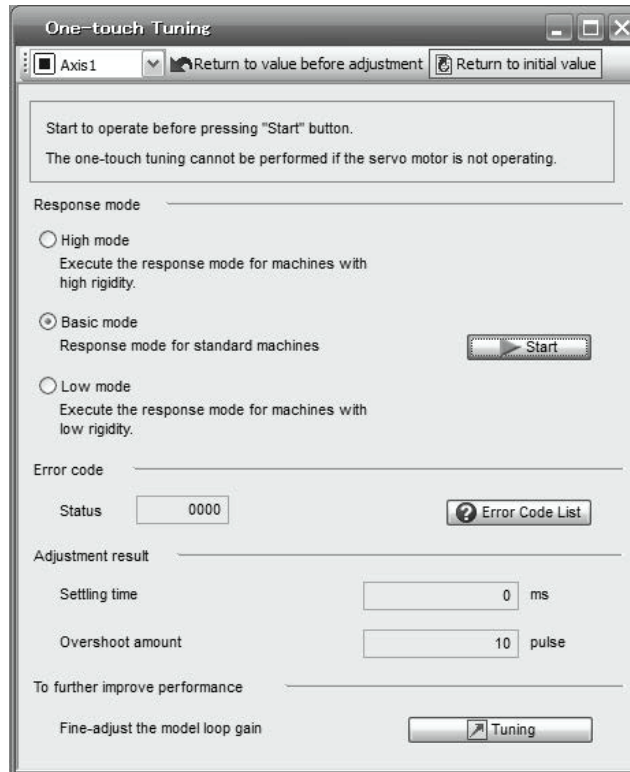

Clearing one-touch tuning is completed, the following window will be displayed. (returning to initial value)

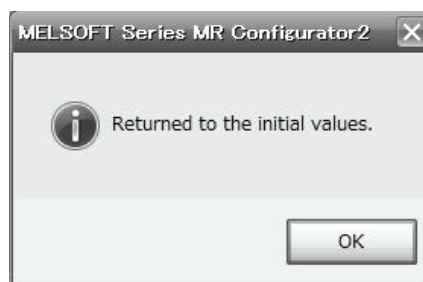

6. NORMAL GAIN ADJUSTMENT

(2) When you use push buttons

(a) Response mode selection

Select a response mode of the one-touch tuning from 3 modes with "UP" or "DOWN".

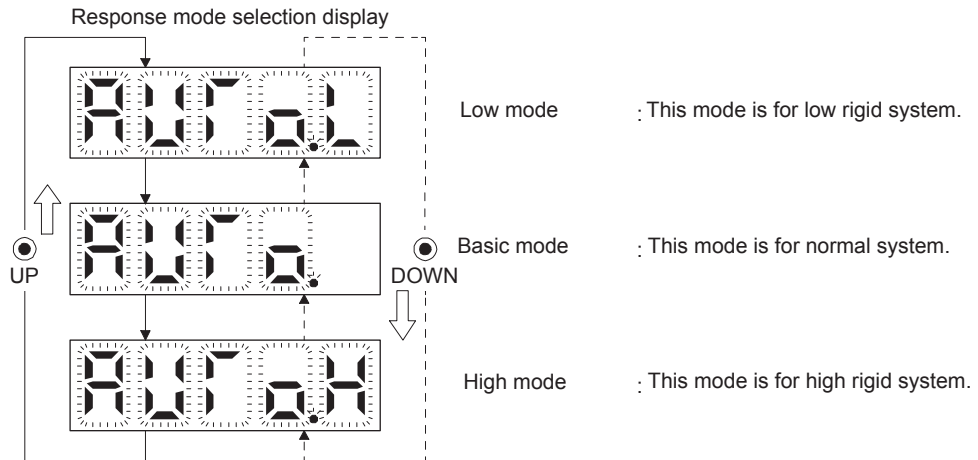

(b) One-touch tuning execution

After the response mode is selected in (a), pushing the "SET" button during driving will start one-touch tuning.

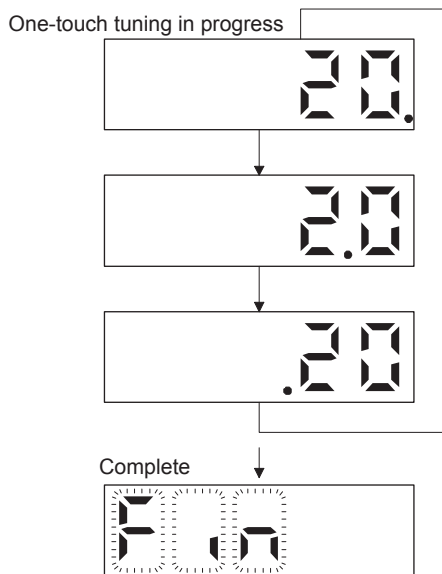

The one-touch tuning progress is displayed with 0% to 100%.
The decimal point moves left to right in rotation during the tuning.
To switch the display to the status display during the tuning, push the "MODE" button.

Completing the one-touch tuning will start writing the auto-tuned parameters to the servo amplifier.

6. NORMAL GAIN ADJUSTMENT

(c) One-touch tuning execution

Stop symbol



The one-touch tuning mode can be stopped by pushing the "SET" button regardless of displayed item.

↕ 2 s interval

Error code



The stop symbol and error code "C 000" (cancel during tuning) will be displayed by turns with 2 s interval.

↓ Pushing the "SET" button will switch to the initial screen.

Initial screen



(d) If an error occur

Stop symbol



If an error occurs during the one-touch tuning, the tuning will be forcibly terminated and the stop symbol and error code from "C 001" to "C 00F" will be displayed by turns with 2 s interval.

↕ 2 s interval

Error code

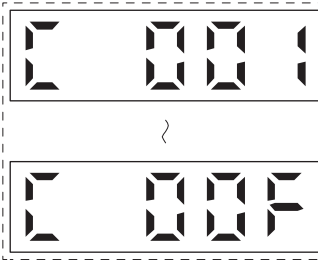

Check the error cause referring table 6.2 of (1)(d) of this section.

↓ Pushing the "SET" button will switch to the initial screen.

Initial screen



(e) If an alarm occur

One-touch tuning in progress



If an alarm occurs during tuning, one-touch tuning will be forcibly terminated and the alarm No. will be displayed.

↓

Alarm display



6. NORMAL GAIN ADJUSTMENT

(f) If a warning occur

One-touch tuning in progress



If a warning occurs during tuning, the alarm No. of the warning will be displayed. When the warning is one which continue the motor driving, the one-touch tuning will be continued.

Alarm display (warning)



(g) Clearing one-touch tuning

Refer to table 6.1 for the parameters which you can clear.

You can initialize the parameters changed by the one-touch tuning with the clear mode. You can reset the parameters to before tuning with the back mode.

1) Push the "MODE" button to switch to the initial screen ("AUTO") of the one-touch tuning.

2) Select the clear mode or back mode with the "UP" or "DOWN" button.

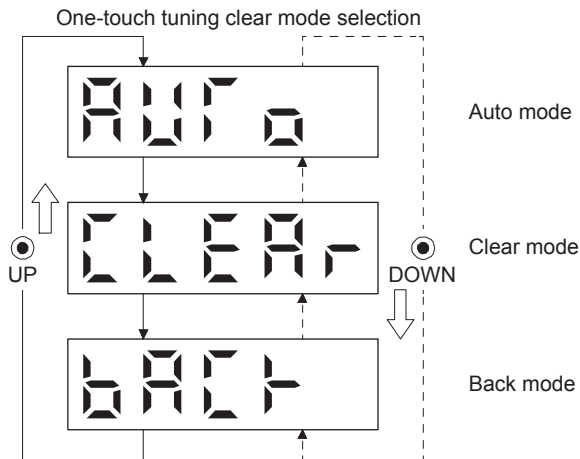

↓ To clear the one-touch tuning, push the "SET" button for 2 s.

One-touch tuning clear mode display (initializing)



The one-touch tuning clear mode is in progress. The clear mode symbol flickers for 3 s.

↓ Clearing one-touch tuning is completed, the initial screen will be displayed.

Initial screen



6. NORMAL GAIN ADJUSTMENT

6.2.3 Caution for one-touch tuning

- (1) The tuning is not available in the torque control mode.
- (2) The one-touch tuning cannot be executed while an alarm or warning which does not continue the motor driving is occurring.
- (3) You can execute the one-touch tuning during the following test operation modes marked by "○".

| How to one-touch tuning | Test operation mode | | | | |
|-------------------------|----------------------------------|---------------|-----------------------|----------------------|-------------------|
| | Output signal (DO) forced output | JOG operation | Positioning operation | Motor-less operation | Program operation |
| MR Configurator2 | | ○ | ○ | | ○ |
| Push buttons | | | | | |

6. NORMAL GAIN ADJUSTMENT

6.3 Auto tuning

6.3.1 Auto tuning mode

The servo amplifier has a real-time auto tuning function which estimates the machine characteristic (load to motor inertia ratio) in real time and automatically sets the optimum gains according to that value. This function permits ease of gain adjustment of the servo amplifier.

(1) Auto tuning mode 1

The servo amplifier is factory-set to the auto tuning mode 1.

In this mode, the load to motor inertia ratio of a machine is always estimated to set the optimum gains automatically.

The following parameters are automatically adjusted in the auto tuning mode 1.

| Parameter | Symbol | Name |
|-----------|--------|-----------------------------|
| PB06 | GD2 | Load to motor inertia ratio |
| PB07 | PG1 | Model loop gain |
| PB08 | PG2 | Position loop gain |
| PB09 | VG2 | Speed loop gain |
| PB10 | VIC | Speed integral compensation |

| POINT |
|---|
| <ul style="list-style-type: none">● The auto tuning mode 1 may not be performed properly if all of the following conditions are not satisfied.<ul style="list-style-type: none">▪ Time to reach 2000 r/min is the acceleration/deceleration time constant of 5 s or less.▪ Speed is 150 r/min or higher.▪ The load to motor inertia ratio is 100 times or less.▪ The acceleration/deceleration torque is 10% or more of the rated torque.● Under operating conditions which will impose sudden disturbance torque during acceleration/deceleration or on a machine which is extremely loose, auto tuning may not function properly, either. In such cases, use the auto tuning mode 2 or manual mode to make gain adjustment. |

(2) Auto tuning mode 2

Use the auto tuning mode 2 when proper gain adjustment cannot be made by auto tuning mode 1. Since the load to motor inertia ratio is not estimated in this mode, set the value of a correct load to motor inertia ratio in [Pr. PB06].

The following parameters are automatically adjusted in the auto tuning mode 2.

| Parameter | Symbol | Name |
|-----------|--------|-----------------------------|
| PB07 | PG1 | Model loop gain |
| PB08 | PG2 | Position loop gain |
| PB09 | VG2 | Speed loop gain |
| PB10 | VIC | Speed integral compensation |

6. NORMAL GAIN ADJUSTMENT

6.3.2 Auto tuning mode basis

The block diagram of real-time auto tuning is shown below.

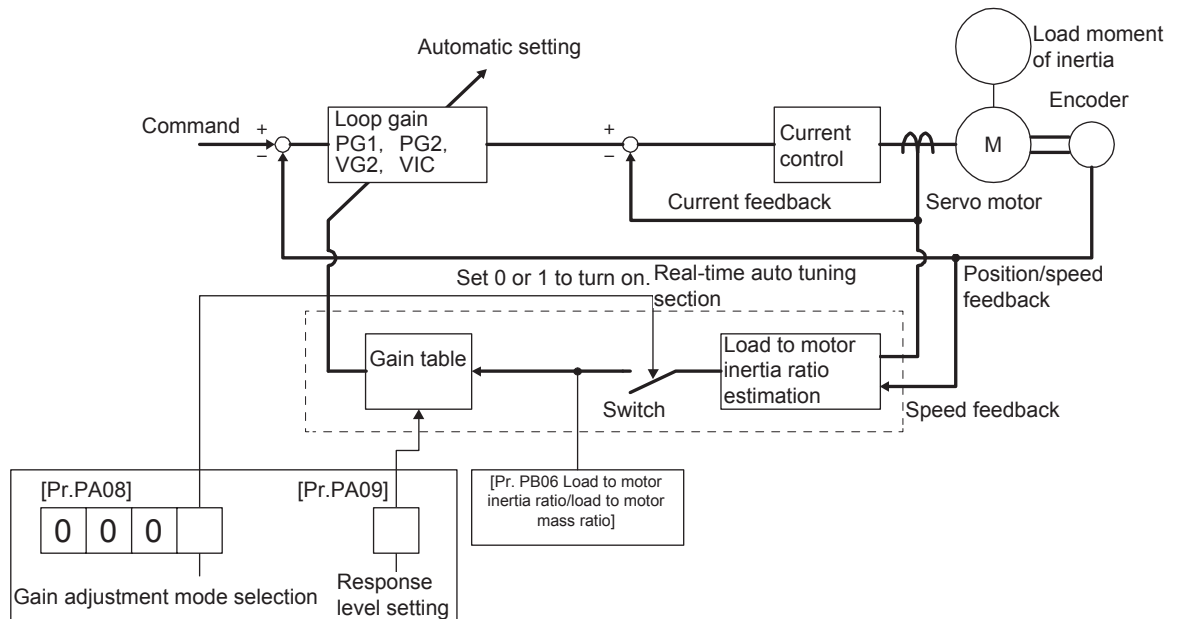

When a servo motor is accelerated/decelerated, the moment of inertia ratio estimation section always estimates the load to motor inertia ratio from the current and speed of the servo motor. The results of estimation are written to [Pr. PB06 Load to motor inertia ratio]. These results can be confirmed on the status display screen of the MR Configurator2.

If the value of the load to motor inertia ratio is already known or if estimation cannot be made properly, set "Gain adjustment mode selection" to "Auto tuning mode 2 (0 0 0 2)" in [Pr. PA08] to stop the estimation (turning off the switch in above diagram), and set the load to motor inertia ratio ([Pr. PB06]) manually. From the preset load to motor inertia ratio [Pr. PB06] value and response [Pr. PA09], the optimum loop gains are automatically set on the basis of the internal gain table.

The auto tuning results are saved in the EEP-ROM of the servo amplifier every 60 minutes since power-on. At power-on, auto tuning is performed with the value of each loop gain saved in the EEP-ROM being used as an initial value.

| POINT |
|--|
| <ul style="list-style-type: none"> ● If sudden disturbance torque is imposed during operation, the load to motor inertia ratio may be misestimated temporarily. In such a case, set "Gain adjustment mode selection" to "Auto tuning mode 2 (0 0 0 2)" in [Pr. PA08] and then set the correct load to motor inertia ratio in [Pr. PB06]. ● When any of the auto tuning mode 1 and auto tuning mode settings is changed to the manual mode 2 setting, the current loop gains and load to motor inertia ratio estimation value are saved in the EEP-ROM. |

6. NORMAL GAIN ADJUSTMENT

6.3.3 Adjustment procedure by auto tuning

Since auto tuning is made valid before shipment from the factory, simply running the servo motor automatically sets the optimum gains that match the machine. Merely changing the response level setting value as required completes the adjustment. The adjustment procedure is as follows.

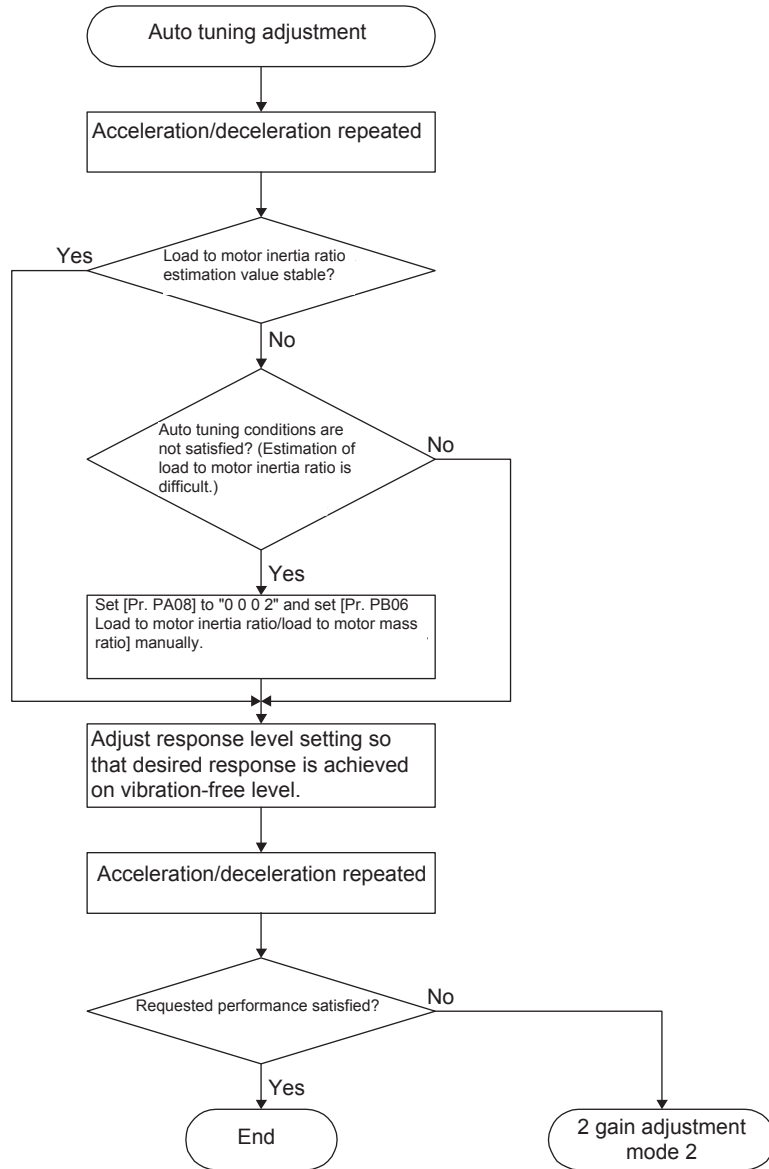

6. NORMAL GAIN ADJUSTMENT

6.3.4 Response level setting in auto tuning mode

Set the response of the whole servo system by [Pr. PA09]. As the response level setting is increased, the track ability and settling time for a command decreases, but a too high response level will generate vibration. Hence, make setting until desired response is obtained within the vibration-free range.

If the response level setting cannot be increased up to the desired response because of machine resonance beyond 100 Hz, filter tuning mode selection in [Pr. PB01] or machine resonance suppression filter in [Pr. PB13] to [Pr. PB16], [Pr. PB46] to [Pr. PB51] may be used to suppress machine resonance. Suppressing machine resonance may allow the response level setting to increase. Refer to section 7.2 and 7.3 for settings of the adaptive tuning mode and machine resonance suppression filter.

[Pr. PA09]

| Setting value | Machine characteristic | | Setting value | Machine characteristic | |
|---------------|---|--|---------------|--|--|
| | Response | Guideline for machine resonance frequency [Hz] | | Response | Guideline for machine resonance frequency [Hz] |
| 1 | Low response ↑ ↓ Middle response | 2.7 | 21 | Middle response ↑ ↓ High response | 67.1 |
| 2 | | 3.6 | 22 | | 75.6 |
| 3 | | 4.9 | 23 | | 85.2 |
| 4 | | 6.6 | 24 | | 95.9 |
| 5 | | 10.0 | 25 | | 108.0 |
| 6 | | 11.3 | 26 | | 121.7 |
| 7 | | 12.7 | 27 | | 137.1 |
| 8 | | 14.3 | 28 | | 154.4 |
| 9 | | 16.1 | 29 | | 173.9 |
| 10 | | 18.1 | 30 | | 195.9 |
| 11 | | 20.4 | 31 | | 220.6 |
| 12 | | 23.0 | 32 | | 248.5 |
| 13 | | 25.9 | 33 | | 279.9 |
| 14 | | 29.2 | 34 | | 315.3 |
| 15 | | 32.9 | 35 | | 355.1 |
| 16 | | 37.0 | 36 | | 400.0 |
| 17 | | 41.7 | 37 | | 446.6 |
| 18 | | 47.0 | 38 | | 501.2 |
| 19 | | 52.9 | 39 | | 571.5 |
| 20 | Middle response | 59.6 | 40 | | High response |

6. NORMAL GAIN ADJUSTMENT

6.4 Manual mode

If you are not satisfied with the adjustment of auto tuning, you can make simple manual adjustment with three parameters.

| POINT |
|--|
| <ul style="list-style-type: none"> ● If machine resonance occurs, filter tuning mode selection in [Pr. PB01] or machine resonance suppression filter in [Pr. PB13] to [Pr. PB16] and [Pr. PB46] to [Pr. PB51] may be used to suppress machine resonance. (Refer to section 7.2 to 7.3.) |

(1) For speed control

(a) Parameter

The following parameters are used for gain adjustment.

| Parameter | Symbol | Name |
|-----------|--------|-----------------------------|
| PB06 | GD2 | Load to motor inertia ratio |
| PB07 | PG1 | Model loop gain |
| PB09 | VG2 | Speed loop gain |
| PB10 | VIC | Speed integral compensation |

(b) Adjustment procedure

| Step | Operation | Description |
|------|--|---|
| 1 | Brief-adjust with auto tuning. Refer to section 6.2.3. | |
| 2 | Change the setting of auto tuning to the manual mode ([Pr. PA08]: 0 0 0 3). | |
| 3 | Set the estimated value to the load to motor inertia ratio. (If the estimate value with auto tuning is correct, setting change is not required.) | |
| 4 | Set a slightly smaller value to the model loop gain Set a slightly larger value to the speed integral compensation. | |
| 5 | Increase the speed loop gain within the vibration- and unusual noise-free range, and return slightly if vibration takes place. | Increase the speed loop gain. |
| 6 | Decrease the speed integral compensation within the vibration-free range, and return slightly if vibration takes place. | Decrease the time constant of the speed integral compensation. |
| 7 | Increase the model loop gain, and return slightly if overshoot takes place. | Increase the model loop gain. |
| 8 | If the gains cannot be increased due to mechanical system resonance or the like and the desired response cannot be achieved, response may be increased by suppressing resonance with the adaptive tuning mode or machine resonance suppression filter and then executing steps 3 to 7. | Suppression of machine resonance Refer to section 7.2 and 7.3. |
| 9 | While checking the motor status, fine-adjust each gain. | Fine adjustment |

6. NORMAL GAIN ADJUSTMENT

(c) Parameter adjustment

1) [Pr. PB09 Speed loop gain]

This parameter determines the response level of the speed control loop. Increasing this value enhances response but a too high value will make the mechanical system liable to vibrate. The actual response frequency of the speed loop is as indicated in the following expression.

$$\text{Speed loop response frequency [Hz]} = \frac{\text{Speed loop gain setting}}{(1 + \text{Load to motor inertia ratio}) \times 2\pi}$$

2) [Pr. PB10 Speed integral compensation]

To eliminate stationary deviation against a command, the speed control loop is under proportional integral control. For the speed integral compensation, set the time constant of this integral control. Increasing the setting lowers the response level. However, if the load to motor inertia ratio is large or the mechanical system has any vibratory element, the mechanical system is liable to vibrate unless the setting is increased to some degree. The guideline is as indicated in the following expression.

$$\text{Speed integral compensation setting [ms]} \geq \frac{2000 \sim 3000}{\text{Speed loop gain setting} / (1 + \text{Load to motor inertia ratio setting})}$$

3) [Pr. PB07 Model loop gain]

This parameter determines the response level to a speed command. Increasing the value improves track ability to a speed command, but a too high value will make overshoot liable to occur at settling.

$$\text{Model loop gain guideline} \leq \frac{\text{Speed loop gain setting}}{(1 + \text{Load to motor inertia ratio}) \times 2\pi} \times \left(\frac{1}{4} \sim \frac{1}{8} \right)$$

(2) For position control

(a) Parameter

The following parameters are used for gain adjustment.

| Parameter | Symbol | Name |
|-----------|--------|-----------------------------|
| PB06 | GD2 | Load to motor inertia ratio |
| PB07 | PG1 | Model loop gain |
| PB08 | PG2 | Position loop gain |
| PB09 | VG2 | Speed loop gain |
| PB10 | VIC | Speed integral compensation |

6. NORMAL GAIN ADJUSTMENT

(b) Adjustment procedure

| Step | Operation | Description |
|------|--|---|
| 1 | Brief-adjust with auto tuning. Refer to section 6.2.3. | |
| 2 | Change the setting of auto tuning to the manual mode ([Pr. PA08]: 0 0 0 3). | |
| 3 | Set the estimated value to the load to motor inertia ratio. (If the estimate value with auto tuning is correct, setting change is not required.) | |
| 4 | Set a slightly smaller value to the model loop gain and the position loop gain. Set a slightly larger value to the speed integral compensation. | |
| 5 | Increase the speed loop gain within the vibration- and unusual noise-free range, and return slightly if vibration takes place. | Increase the speed loop gain. |
| 6 | Decrease the speed integral compensation within the vibration-free range, and return slightly if vibration takes place. | Decrease the time constant of the speed integral compensation. |
| 7 | Increase the position loop gain, and return slightly if vibration takes place. | Increase the position loop gain. |
| 8 | Increase the model loop gain, and return slightly if overshoot takes place. | Increase the model loop gain. |
| 9 | If the gains cannot be increased due to mechanical system resonance or the like and the desired response cannot be achieved, response may be increased by suppressing resonance with the adaptive tuning mode or machine resonance suppression filter and then executing steps 3 to 8. | Suppression of machine resonance Refer to section 7.2 and 7.3. |
| 10 | While checking the settling characteristic and motor status, fine-adjust each gain. | Fine adjustment |

(c) Parameter adjustment

1) [Pr. PB09 Speed loop gain]

This parameter determines the response level of the speed control loop. Increasing this value enhances response but a too high value will make the mechanical system liable to vibrate. The actual response frequency of the speed loop is as indicated in the following expression.

$$\text{Speed loop response frequency [Hz]} = \frac{\text{Speed loop gain setting}}{(1 + \text{Load to motor inertia ratio}) \times 2\pi}$$

2) [Pr. PB10 Speed integral compensation]

To eliminate stationary deviation against a command, the speed control loop is under proportional integral control. For the speed integral compensation, set the time constant of this integral control. Increasing the setting lowers the response level. However, if the load to motor inertia ratio is large or the mechanical system has any vibratory element, the mechanical system is liable to vibrate unless the setting is increased to some degree. The guideline is as indicated in the following expression.

$$\geq \frac{\text{Speed integral compensation setting [ms]} \quad 2000 \sim 3000}{\text{Speed loop gain setting} / (1 + \text{Load to motor inertia ratio setting})}$$

6. NORMAL GAIN ADJUSTMENT

3) [Pr. PB08 Position loop gain]

This parameter determines the response level to a disturbance to the position control loop. Increasing the value increases the response level to the disturbance, but a too high value will increase vibration of the mechanical system.

$$\text{Position loop gain guideline} \leq \frac{\text{Speed loop gain setting}}{(1 + \text{Load to motor inertia ratio}) \times 2\pi} \times \left(\frac{1}{4} \sim \frac{1}{8} \right)$$

4) [Pr. PB07 Model loop gain]

This parameter determines the response level to a position command. Increasing the value improves track ability to a position command, but a too high value will make overshoot liable to occur at settling.

$$\text{Model loop gain guideline} \leq \frac{\text{Speed loop gain setting}}{(1 + \text{Load to motor inertia ratio}) \times 2\pi} \times \left(\frac{1}{4} \sim \frac{1}{8} \right)$$

6. NORMAL GAIN ADJUSTMENT

6.5 2 gain adjustment mode

The 2 gain adjustment mode is used to match the position loop gains of the axes when performing the interpolation operation of servo motors of two or more axes for an X-Y table or the like. In this mode, manually set the model loop gain that determines command track ability. Other parameters for gain adjustment are set automatically.

(1) 2 gain adjustment mode 1 (interpolation mode)

The 2 gain adjustment mode 1 manually set the model loop gain that determines command track ability. The mode constantly estimates the load to motor inertia ratio, and automatically set other parameters for gain adjustment to optimum gains using auto tuning response. The following parameters are used for 2 gain adjustment mode 1.

(a) Automatically adjusted parameter

The following parameters are automatically adjusted by auto tuning.

| Parameter | Symbol | Name |
|-----------|--------|-----------------------------|
| PB06 | GD2 | Load to motor inertia ratio |
| PB08 | PG2 | Position loop gain |
| PB09 | VG2 | Speed loop gain |
| PB10 | VIC | Speed integral compensation |

(b) Manually adjusted parameter

The following parameters are adjustable manually.

| Parameter | Symbol | Name |
|-----------|--------|----------------------|
| PA09 | RSP | Auto tuning response |
| PB07 | PG1 | Model loop gain |

(2) 2 gain adjustment mode 2

Use 2 gain adjustment mode 2 when proper gain adjustment cannot be made with 2 gain adjustment mode 1. Since the load to motor inertia ratio is not estimated in this mode, set the value of a proper load to motor inertia ratio in [Pr. PB06].

The following parameters are used for 2 gain adjustment mode 2.

(a) Automatically adjusted parameter

The following parameters are automatically adjusted by auto tuning.

| Parameter | Symbol | Name |
|-----------|--------|-----------------------------|
| PB08 | PG2 | Position loop gain |
| PB09 | VG2 | Speed loop gain |
| PB10 | VIC | Speed integral compensation |

(b) Manually adjusted parameter

The following parameters are adjustable manually.

| Parameter | Symbol | Name |
|-----------|--------|-----------------------------|
| PA09 | RSP | Auto tuning response |
| PB06 | GD2 | Load to motor inertia ratio |
| PB07 | PG1 | Model loop gain |

6. NORMAL GAIN ADJUSTMENT

(3) Adjustment procedure of 2 gain adjustment mode

| | |
|--|--|
| POINT | |
| <p>● Set the same value in [Pr. PB07 Model loop gain] for the axis used in 2 gain adjustment mode.</p> | |

| Step | Operation | Description |
|------|---|---|
| 1 | Set to the auto tuning mode. | Select the auto tuning mode 1. |
| 2 | During operation, increase the response level setting value in [Pr. PA09], and return the setting if vibration occurs. | Adjustment in auto tuning mode 1. |
| 3 | Check value of the model loop gain and the load to motor inertia ratio in advance. | Check the upper setting limits. |
| 4 | Set the 2 gain adjustment mode 1 ([Pr. PA08]: 0 0 0 0). | Select the 2 gain adjustment mode 1 (interpolation mode). |
| 5 | When the load to motor inertia ratio is different from the design value, select the 2 gain adjustment mode 2 ([Pr. PA08]: 0 0 0 4) and then set the load to motor inertia ratio manually in [Pr. PB06]. | Check the load to motor inertia ratio. |
| 6 | Set the model loop gain of all the axes to be interpolated to the same value. At that time, adjust to the setting value of the axis, which has the smallest model loop gain. | Set position loop gain. |
| 7 | Considering the interpolation characteristic and motor status, fine-adjust the model loop gain and response level setting. | Fine adjustment |

(4) Parameter adjustment

[Pr. PB07 Model loop gain]

This parameter determines the response level of the position control loop. Increasing the value improves track ability to a position command, but a too high value will make overshoot liable to occur at settling.

The droop pulse value is determined by the following expression.

$$\text{Number of droop pulses [pulse]} = \frac{\text{Position command frequency [pulse/s]}}{\text{Model loop gain setting}}$$

Position command frequency differs depending on the operation mode.

$$\text{Position command frequency} = \frac{\text{Speed [r/min]}}{60} \times \text{Encoder resolution (number of pulses per servo motor revolution)}$$

7. SPECIAL ADJUSTMENT FUNCTIONS

7. SPECIAL ADJUSTMENT FUNCTIONS

| POINT |
|---|
| <ul style="list-style-type: none"> ● The functions given in this chapter need not be used normally. Use them if you are not satisfied with the machine status after making adjustment in the methods in chapter 6. |

7.1 Filter setting

The following filters are available with MR-J4 servo amplifiers.

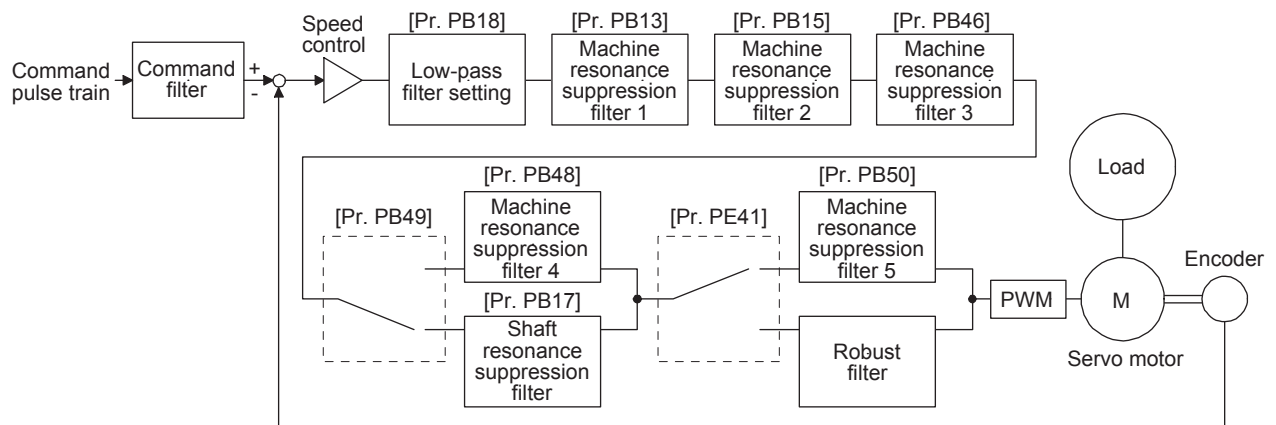

7.1.1 Machine resonance suppression filter

| POINT |
|---|
| <ul style="list-style-type: none"> ● The machine resonance suppression filter is a delay factor for the servo system. Therefore, vibration may increase if you set an incorrect resonance frequency or set notch characteristics too deep or too wide. ● If the frequency of machine resonance is unknown, decrease the notch frequency from higher to lower ones in order. The optimum notch frequency is set at the point where vibration is minimal. ● A deeper notch has a higher effect on machine resonance suppression but increases a phase delay and may increase vibration. ● A deeper notch has a higher effect on machine resonance suppression but increases a phase delay and may increase vibration. ● The machine characteristic can be grasped beforehand by the machine analyzer on MR Configurator2. This allows the required notch frequency and notch characteristics to be determined. |

If a mechanical system has a natural resonance point, increasing the servo system response level may cause the mechanical system to produce resonance (vibration or unusual noise) at that resonance frequency. Using the machine resonance suppression filter and adaptive tuning can suppress the resonance of the mechanical system. The setting range is 10 Hz to 4500 Hz.

7. SPECIAL ADJUSTMENT FUNCTIONS

(1) Function

The machine resonance suppression filter is a filter function (notch filter) which decreases the gain of the specific frequency to suppress the resonance of the mechanical system. You can set the gain decreasing frequency (notch frequency), gain decreasing depth and width.

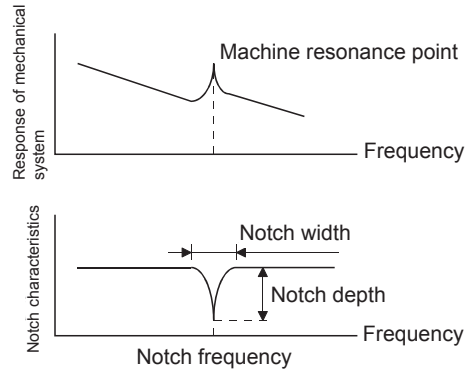

You can set five machine resonance suppression filters at most.

| Filter | Setting parameter | Precaution | Parameter that is reset with vibration tough drive function | Parameter automatically adjusted with one-touch tuning |
|--|-------------------|---|---|--|
| Machine resonance suppression filter 1 | PB01/PB13/PB14 | The filter can be set automatically with "Filter tuning mode selection" in [Pr. PB01]. | PB13 | PB01/PB13/PB14 |
| Machine resonance suppression filter 2 | PB15/PB16 | | PB15 | PB15/PB16 |
| Machine resonance suppression filter 3 | PB46/PB47 | | | PB47 |
| Machine resonance suppression filter 4 | PB48/PB49 | Enabling the filter disables the shaft resonance suppression filter. The shaft resonance suppression filter is enabled for the initial setting. | | PB48/PB49 |
| Machine resonance suppression filter 5 | PB50/PB51 | The setting of this filter is disabled while you use the robust filter. The robust filter is disabled for the initial setting. | | PB51 |

7. SPECIAL ADJUSTMENT FUNCTIONS

(2) Parameter

(a) Machine resonance suppression filter 1 ([Pr. PB13] and [Pr. PB14])

Set the notch frequency, notch depth and notch width of the machine resonance suppression filter 1 ([Pr. PB13] and [Pr. PB14])

When you select "Manual setting (_ _ _ 2)" of "Filter tuning mode selection" in [Pr. PB01], the setting of the machine resonance suppression filter 1 is enabled.

(b) Machine resonance suppression filter 2 ([Pr. PB15] and [Pr. PB16])

To use this filter, select "Enabled (_ _ _ 1)" of "Machine resonance suppression filter 2 selection" in [Pr. PB16].

How to set the machine resonance suppression filter 2 ([Pr. PB15] and [Pr. PB16]) is the same as for the machine resonance suppression filter 1 ([Pr. PB13] and [Pr. PB14]).

(c) Machine resonance suppression filter 3 ([Pr. PB46] and [Pr. PB47])

To use this filter, select "Enabled (_ _ _ 1)" of "Machine resonance suppression filter 3 selection" in [Pr. PB47].

How to set the machine resonance suppression filter 3 ([Pr. PB46] and [Pr. PB47]) is the same as for the machine resonance suppression filter 1 ([Pr. PB13] and [Pr. PB14]).

(d) Machine resonance suppression filter 4 ([Pr. PB48] and [Pr. PB49])

To use this filter, select "Enabled (_ _ _ 1)" of "Machine resonance suppression filter 4 selection" in [Pr. PB49]. However, enabling the machine resonance suppression filter 4 disables the shaft resonance suppression filter.

How to set the machine resonance suppression filter 4 ([Pr. PB48] and [Pr. PB49]) is the same as for the machine resonance suppression filter 1 ([Pr. PB13] and [Pr. PB14]).

(e) Machine resonance suppression filter 5 ([Pr. PB50] and [Pr. PB51])

To use this filter, select "Enabled (_ _ _ 1)" of "Machine resonance suppression filter 5 selection" in [Pr. PB51]. However, enabling the robust filter ([Pr. PE41: _ _ _ 1]) disables the machine resonance suppression filter 5.

How to set the machine resonance suppression filter 5 ([Pr. PB50] and [Pr. PB51]) is the same as for the machine resonance suppression filter 1 ([Pr. PB13] and [Pr. PB14]).

7. SPECIAL ADJUSTMENT FUNCTIONS

7.1.2 Adaptive filter II

| POINT |
|--|
| <ul style="list-style-type: none"> ● The machine resonance frequency which adaptive filter II (adaptive tuning) can respond to is about 100 Hz to 2.25 kHz. As for the resonance frequency out of the range, set manually. ● When adaptive tuning is executed, vibration sound increases as an excitation signal is forcibly applied for several seconds. ● When adaptive tuning is executed, machine resonance is detected for a maximum of 10 seconds and a filter is generated. After filter generation, the adaptive tuning mode automatically shifts to the manual setting. ● Adaptive tuning generates the optimum filter with the currently set control gains. If vibration occurs when the response setting is increased, execute adaptive tuning again. ● During adaptive tuning, a filter having the best notch depth at the set control gain is generated. To allow a filter margin against machine resonance, increase the notch depth in the manual setting. ● Adaptive vibration suppression control may provide no effect on a mechanical system which has complex resonance characteristics. |

(1) Function

Adaptive filter II (adaptive tuning) is a function in which the servo amplifier detects machine vibration for a predetermined period of time and sets the filter characteristics automatically to suppress mechanical system vibration. Since the filter characteristics (frequency, depth) are set automatically, you need not be conscious of the resonance frequency of a mechanical system.

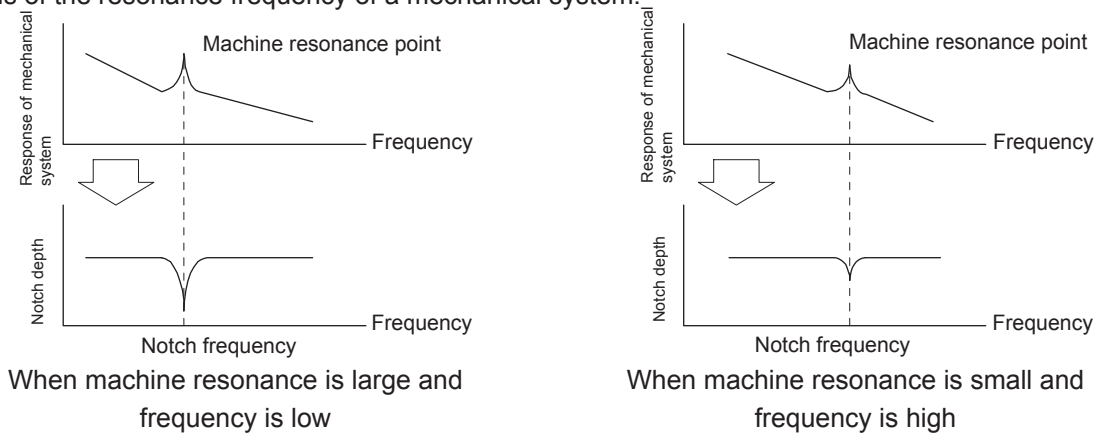

(2) Parameter

Select how to set the filter tuning in [Pr. PB01 Adaptive tuning mode (adaptive filter II)].

[Pr.PB01]

| | | | |
|---|---|---|--|
| 0 | 0 | 0 | |
|---|---|---|--|

└ Filter tuning mode selection

| Setting value | Filter tuning mode selection | Automatically set parameter |
|---------------|------------------------------|-----------------------------|
| 0 | Disabled | |
| 1 | Automatic setting | PB13 · PB14 |
| 2 | Manual setting | |

7. SPECIAL ADJUSTMENT FUNCTIONS

(3) Adaptive tuning mode procedure

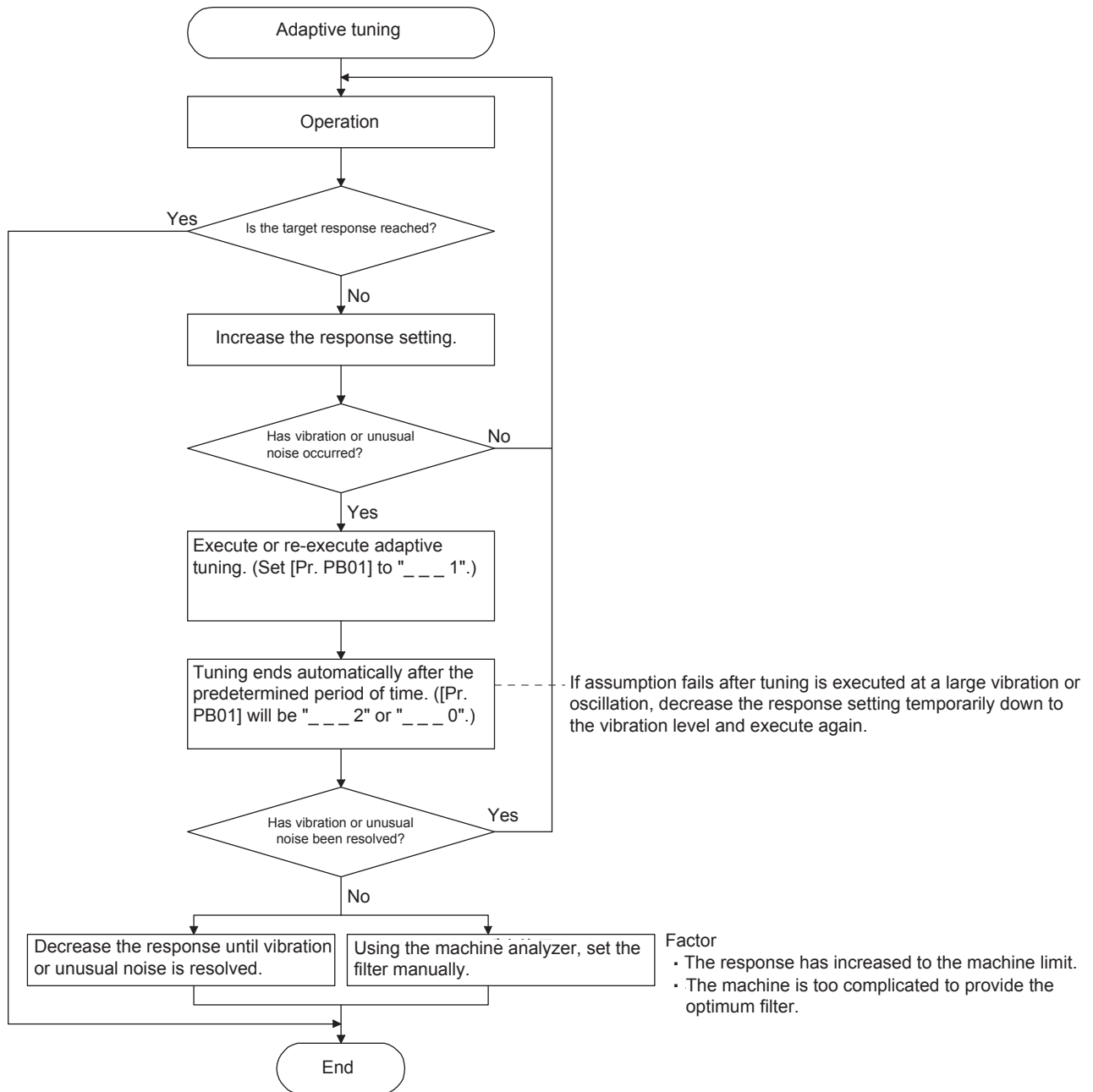

7. SPECIAL ADJUSTMENT FUNCTIONS

7.1.3 Shaft resonance suppression filter

(1) Function

When a load is mounted to the servo motor shaft, resonance by shaft torsion during driving may generate a mechanical vibration at high frequency. The shaft resonance suppression filter suppresses the vibration.

When you select "Automatic setting", the filter will be set automatically on the basis of the motor you use and the load to motor inertia ratio. The enabled setting increases the response of the servo amplifier for high resonance frequency.

(2) Parameter

Set "Shaft resonance suppression filter selection" in [Pr. PB23].

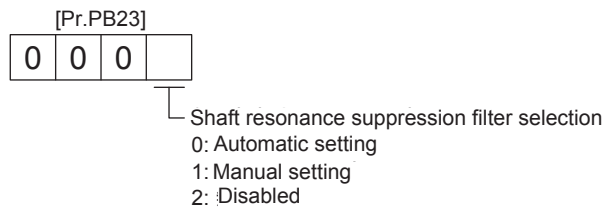

To set [Pr. PB17 Shaft resonance suppression filter] automatically, select "Automatic setting".

To set [Pr. PB17 Shaft resonance suppression filter] manually, select "Manual setting". The setting values are as follows.

Shaft resonance suppression filter setting frequency selection

| Setting value | Frequency [Hz] | Setting value | Frequency [Hz] |
|---------------|----------------|---------------|----------------|
| __ 0 0 | Disabled | __ 1 0 | 562 |
| __ 0 1 | Disabled | __ 1 1 | 529 |
| __ 0 2 | 4500 | __ 1 2 | 500 |
| __ 0 3 | 3000 | __ 1 3 | 473 |
| __ 0 4 | 2250 | __ 1 4 | 450 |
| __ 0 5 | 1800 | __ 1 5 | 428 |
| __ 0 6 | 1500 | __ 1 6 | 409 |
| __ 0 7 | 1285 | __ 1 7 | 391 |
| __ 0 8 | 1125 | __ 1 8 | 375 |
| __ 0 9 | 1000 | __ 1 9 | 360 |
| __ 0 A | 900 | __ 1 A | 346 |
| __ 0 B | 818 | __ 1 B | 333 |
| __ 0 C | 750 | __ 1 C | 321 |
| __ 0 D | 692 | __ 1 D | 310 |
| __ 0 E | 642 | __ 1 E | 300 |
| __ 0 F | 600 | __ 1 F | 290 |

7. SPECIAL ADJUSTMENT FUNCTIONS

7.1.4 Low-pass filter

(1) Function

When a ball screw or the like is used, resonance of high frequency may occur as the response level of the servo system is increased. To prevent this, the low-pass filter is enabled for a torque command as a default. The filter frequency of the low-pass filter is automatically adjusted to the value in the following equation.

$$\text{Filter frequency ([rad/s])} = \frac{VG2}{1 + GD2} \times 10$$

To set [Pr. PB18] manually, select "Manual setting (_ _ 1 _)" of "Low-pass filter selection" in [Pr. PB23].

(2) Parameter

Set "Low-pass filter selection" in [Pr. PB23].

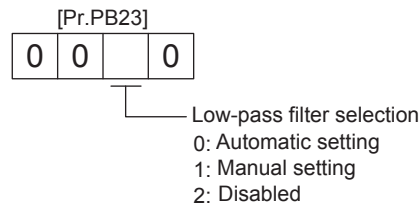

7.1.5 Advanced vibration suppression control II

| POINT |
|---|
| ● The function is enabled when "Gain adjustment mode selection" in [Pr. PA08] is "Auto tuning mode 2 (_ _ _ 2)", "Manual mode (_ _ _ 3)", or "2 gain adjustment mode 2 (_ _ _ 4)". |
| ● The machine resonance frequency supported in the vibration suppression control tuning mode is 1.0 Hz to 100.0 Hz. As for the vibration out of the range, set manually. |
| ● Stop the servo motor before changing the vibration suppression control-related parameters. Otherwise, it may cause an unexpected operation. |
| ● For positioning operation during execution of vibration suppression control tuning, provide a stop time to ensure a stop after vibration damping. |
| ● Vibration suppression control tuning may not make normal estimation if the residual vibration at the servo motor side is small. |
| ● Vibration suppression control tuning sets the optimum parameter with the currently set control gains. When the response setting is increased, set vibration suppression control tuning again. |
| ● When using the vibration suppression control 2, set " _ _ _ 1" in [Pr. PA24]. |

7. SPECIAL ADJUSTMENT FUNCTIONS

(1) Function

Vibration suppression control is used to further suppress load-side vibration, such as work-side vibration and base shake. The servo motor-side operation is adjusted for positioning so that the machine does not vibrate.

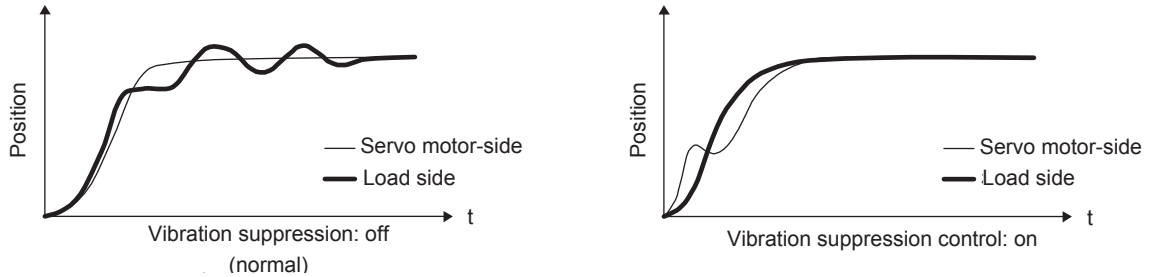

When the advanced vibration suppression control II ([Pr. PB02 Vibration suppression control tuning mode]) is executed, the vibration frequency at load side is automatically estimated to suppress machine side vibration two times at most.

In the vibration suppression control tuning mode, this mode shifts to the manual setting after the positioning operation is performed the predetermined number of times. For manual setting, adjust the vibration suppression control 1 with [Pr. PB19] to [Pr. PB22] and vibration suppression control 2 with [Pr. PB52] to [Pr. PB55].

(2) Parameter

Set [Pr. PB02 Vibration suppression control tuning mode (advanced vibration suppression control II)].

When you use a vibration suppression control, set "Vibration suppression control 1 tuning mode selection". When you use two vibration suppression controls, set "Vibration suppression control 2 tuning mode selection" in addition.

[Pr. PB02]
0 0

Vibration suppression control 1 tuning mode

| Setting value | Vibration suppression control 1 tuning mode selection | Automatically set parameter |
|---------------|---|-----------------------------|
| __ 0 | Disabled | |
| __ 1 | Automatic setting | PB19 · PB20 · PB21 · PB22 |
| __ 2 | Manual setting | |

Vibration suppression control 2 tuning mode

| Setting value | Vibration suppression control 2 tuning mode selection | Automatically set parameter |
|---------------|---|-----------------------------|
| __ 0 | Disabled | |
| __ 1 | Automatic setting | PB52 · PB53 · PB54 · PB55 |
| __ 2 | Manual setting | |

7. SPECIAL ADJUSTMENT FUNCTIONS

(3) Vibration suppression control tuning procedure

The following flow chart is for the vibration suppression control 1. For the vibration suppression control 2, set " __ 1 _ " in [Pr. PB02] to execute the vibration suppression control tuning.

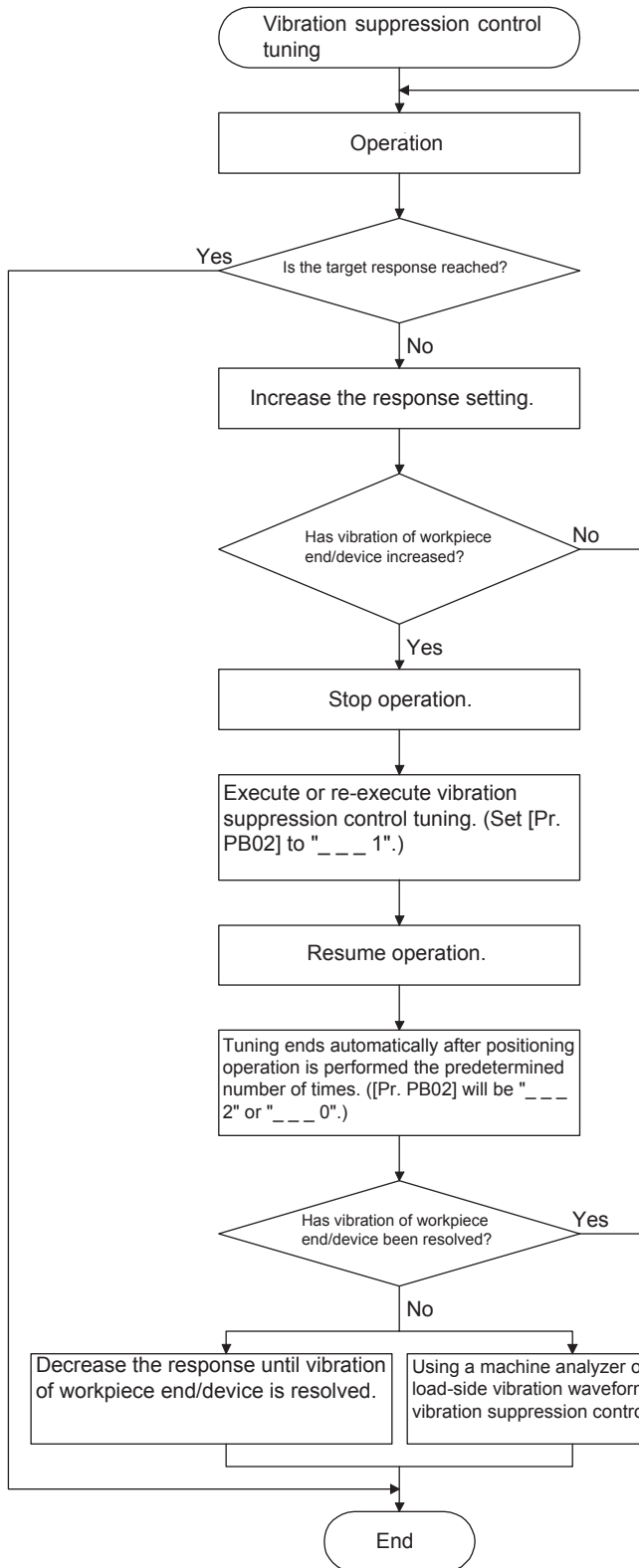

Factor

- Estimation cannot be made as load-side vibration has not been transmitted to the servo motor side.
- The response of the model loop gain has increased to the load-side vibration frequency (vibration suppression control limit).

7. SPECIAL ADJUSTMENT FUNCTIONS

(4) Vibration suppression control manual mode

| POINT | |
|-------|---|
| | <ul style="list-style-type: none"> ● When load-side vibration does not show up in servo motor-side vibration, the setting of the servo motor-side vibration frequency does not produce an effect. ● When the anti-resonance frequency and resonance frequency can be confirmed using the machine analyzer or external equipment, do not set the same value but set different values to improve the vibration suppression performance. ● A vibration suppression control effect is not produced if the relation between the [Pr. PB07 Model loop gain] value and vibration frequency is as follows. Vibration suppression control 1: $[\text{Pr. PB19}] < \frac{1}{2\pi} (0.9 \times [\text{Pr. PB07}])$ $[\text{Pr. PB20}] < \frac{1}{2\pi} (0.9 \times [\text{Pr. PB07}])$ Vibration suppression control 2: $[\text{Pr. PB52}] < 5.0 + 0.1 \times [\text{Pr. PB07}]$ $[\text{Pr. PB53}] < 5.0 + 0.1 \times [\text{Pr. PB07}]$ |

Measure work-side vibration and device shake with the machine analyzer or external measuring instrument, and set the following parameters to adjust vibration suppression control manually.

| Setting item | Vibration suppression control 1 | Vibration suppression control 2 |
|---|---------------------------------|---------------------------------|
| Vibration suppression control – Vibration frequency | [Pr. PB19] | [Pr. PB52] |
| Vibration suppression control – Resonance frequency | [Pr. PB20] | [Pr. PB53] |
| Vibration suppression control – Vibration frequency dumping setting | [Pr. PB21] | [Pr. PB54] |
| Vibration suppression control – Resonance frequency dumping setting | [Pr. PB22] | [Pr. PB55] |

Step 1 Select "Manual setting (_ _ _ 2)" of "Vibration suppression control 1 tuning mode selection" or "Manual setting (_ _ 2 _)" of "Vibration suppression control 2 tuning mode selection" in [Pr. PB02].

Step 2 Set "Vibration suppression control - Vibration frequency" and "Vibration suppression control - Resonance frequency" as follows.

7. SPECIAL ADJUSTMENT FUNCTIONS

- (a) When a vibration peak can be confirmed with machine analyzer using MR Configurator2, or external equipment.

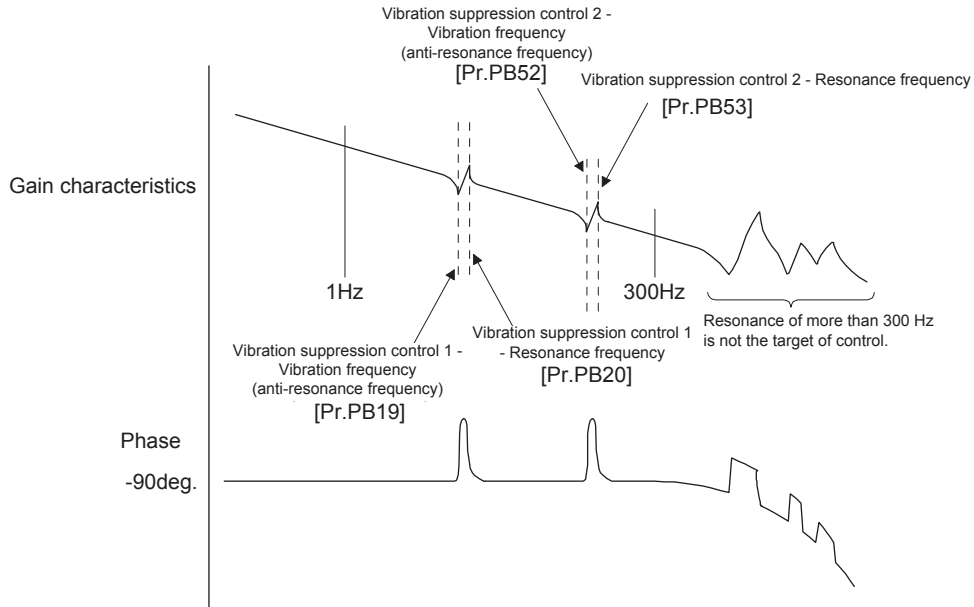

- (b) When vibration can be confirmed using monitor signal or external sensor

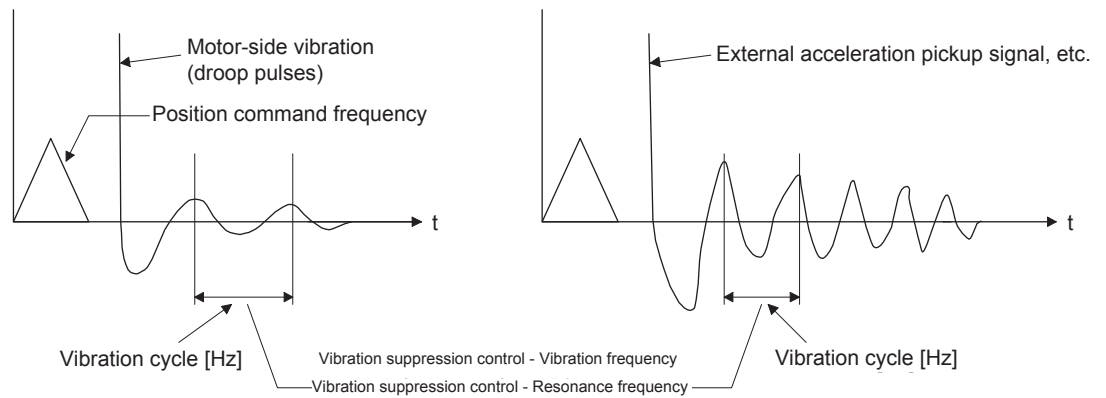

Set the same value.

- Step 3 Fine-adjust "Vibration suppression control - Vibration frequency dumping setting" and "Vibration suppression control - Resonance frequency dumping setting".

7. SPECIAL ADJUSTMENT FUNCTIONS

7.1.6 Command notch filter

| POINT |
|--|
| ●By using the advanced vibration suppression control II and the command notch filter, the load-side vibration of three frequencies can be suppressed. |
| ●The frequency range of machine vibration, which can be supported by the command notch filter, is between 4.5 Hz and 2250 Hz. Set a frequency close to the machine vibration frequency and within the range. |
| ●When [Pr. PB45 Command notch filter] is changed during the positioning operation, the changed setting is not reflected. The setting is reflected approximately 150 ms after the servo motor stops (after servo-lock). |

(1) Function

Command notch filter has a function that lowers the gain of the specified frequency contained in a position command. By lowering the gain, load-side vibration, such as work-side vibration and base shake, can be suppressed. Which frequency to lower the gain and how deep to lower the gain can be set.

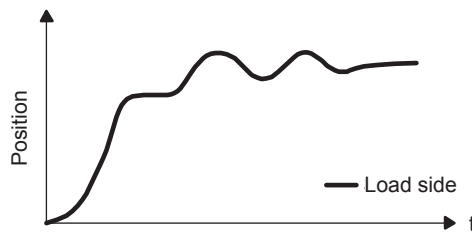

Command notch filter: disabled

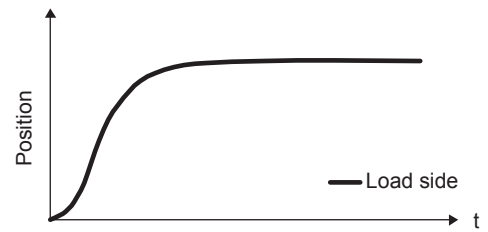

Command notch filter: enabled

7. SPECIAL ADJUSTMENT FUNCTIONS

(2) Parameter

Set [Pr. PB45 Command notch filter] as shown below. For the command notch filter setting frequency, set the closest value to the vibration frequency [Hz] at the load side.

[Pr.PB45]

0

Notch depth Control command from controller

| Setting value | Depth [dB] |
|---------------|------------|
| 0 | -40.0 |
| 1 | -24.1 |
| 2 | -18.1 |
| 3 | -14.5 |
| 4 | -12.0 |
| 5 | -10.1 |
| 6 | -8.5 |
| 7 | -7.2 |
| 8 | -6.0 |
| 9 | -5.0 |
| A | -4.1 |
| B | -3.3 |
| C | -2.5 |
| D | -1.8 |
| E | -1.2 |
| F | -0.6 |

| Setting value | Frequency [Hz] |
|---------------|----------------|
| 00 | Disabled |
| 01 | 2250 |
| 02 | 1125 |
| 03 | 750 |
| 04 | 562 |
| 05 | 450 |
| 06 | 375 |
| 07 | 321 |
| 08 | 281 |
| 09 | 250 |
| 0A | 225 |
| 0B | 204 |
| 0C | 187 |
| 0D | 173 |
| 0E | 160 |
| 0F | 150 |
| 10 | 140 |
| 11 | 132 |
| 12 | 125 |
| 13 | 118 |
| 14 | 112 |
| 15 | 107 |
| 16 | 102 |
| 17 | 97 |
| 18 | 93 |
| 19 | 90 |
| 1A | 86 |
| 1B | 83 |
| 1C | 80 |
| 1D | 77 |
| 1E | 75 |
| 1F | 72 |

| Setting value | Frequency [Hz] |
|---------------|----------------|
| 20 | 70 |
| 21 | 66 |
| 22 | 62 |
| 23 | 59 |
| 24 | 56 |
| 25 | 53 |
| 26 | 51 |
| 27 | 48 |
| 28 | 46 |
| 29 | 45 |
| 2A | 43 |
| 2B | 41 |
| 2C | 40 |
| 2D | 38 |
| 2E | 37 |
| 2F | 36 |
| 30 | 35.2 |
| 31 | 33.1 |
| 32 | 31.3 |
| 33 | 29.6 |
| 34 | 28.1 |
| 35 | 26.8 |
| 36 | 25.6 |
| 37 | 24.5 |
| 38 | 23.4 |
| 39 | 22.5 |
| 3A | 21.6 |
| 3B | 20.8 |
| 3C | 20.1 |
| 3D | 19.4 |
| 3E | 18.8 |
| 3F | 18.2 |

| Setting value | Frequency [Hz] |
|---------------|----------------|
| 40 | 17.6 |
| 41 | 16.5 |
| 42 | 15.6 |
| 43 | 14.8 |
| 44 | 14.1 |
| 45 | 13.4 |
| 46 | 12.8 |
| 47 | 12.2 |
| 48 | 11.7 |
| 49 | 11.3 |
| 4A | 10.8 |
| 4B | 10.4 |
| 4C | 10.0 |
| 4D | 9.7 |
| 4E | 9.4 |
| 4F | 9.1 |
| 50 | 8.8 |
| 51 | 8.3 |
| 52 | 7.8 |
| 53 | 7.4 |
| 54 | 7.0 |
| 55 | 6.7 |
| 56 | 6.4 |
| 57 | 6.1 |
| 58 | 5.9 |
| 59 | 5.6 |
| 5A | 5.4 |
| 5B | 5.2 |
| 5C | 5.0 |
| 5D | 4.9 |
| 5E | 4.7 |
| 5F | 4.5 |

7. SPECIAL ADJUSTMENT FUNCTIONS

7.2 Gain switching function

You can switch gains with the function. You can switch gains during rotation and during stop, and can use a input device to switch gains during operation.

7.2.1 Applications

The following shows when you use the function.

- (1) You want to increase the gains during servo-lock but decrease the gains to reduce noise during rotation.
- (2) You want to increase the gains during settling to shorten the stop settling time.
- (3) You want to change the gains using a input device to ensure stability of the servo system since the load to motor inertia ratio varies greatly during a stop (e.g. a large load is mounted on a carrier).

7. SPECIAL ADJUSTMENT FUNCTIONS

7.2.2 Function block diagram

The control gains, load to motor inertia ratio, and vibration suppression control settings are changed according to the conditions selected by [Pr. PB26 Gain switching function] and [Pr. PB27 Gain switching condition].

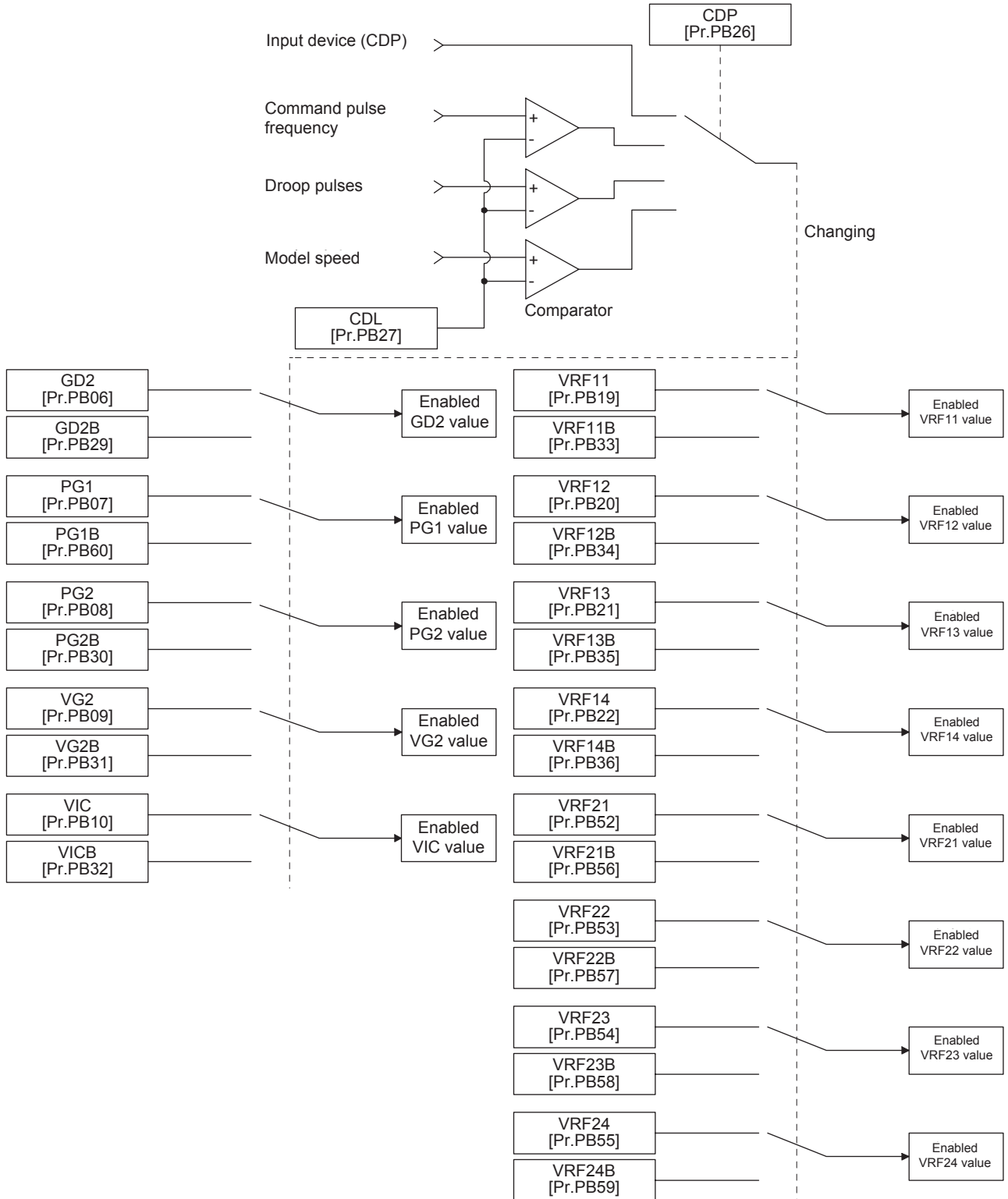

7. SPECIAL ADJUSTMENT FUNCTIONS

7.2.3 Parameter

When using the gain switching function, always select "Manual mode (_ _ _ 3)" of "Gain adjustment mode selection" in [Pr. PA08 Auto tuning mode]. The gain switching function cannot be used in the auto tuning mode.

(1) Variable gain operation setting parameter

| Parameter | Symbol | Name | Unit | Description |
|-----------|--------|------------------------------|--------------------------------|---|
| PB26 | CDP | Gain switching selection | | Used to select the changing condition. |
| PB27 | CDL | Gain switching condition | [kpps] /[pulse] /[r/min] | Used to set the changing condition values. |
| PB28 | CDT | Gain switching time constant | [ms] | You can set the filter time constant for a gain change at changing. |

(a) [Pr. PB26 Gain switching function]

Used to set the gain switching condition. Select the switching condition in the first digit and second digit.

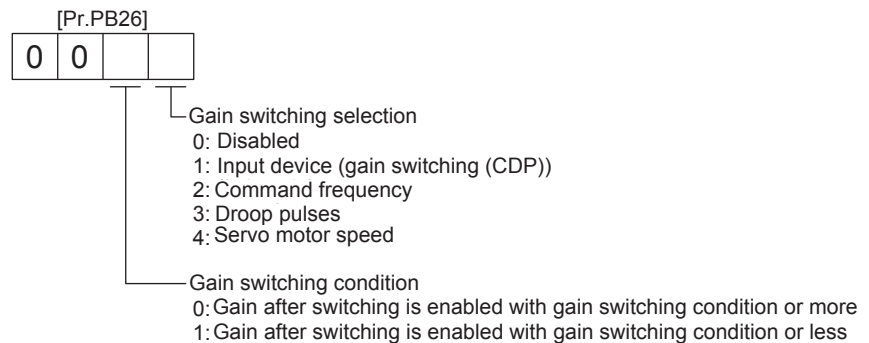

(b) [Pr. PB27 Gain switching condition]

Set a level to switch gains after you select "Command frequency", "Droop pulses", or "Servo motor speed" in [Pr. PB26 Gain switching function].

The setting unit is as follows.

| Gain switching condition | Unit |
|--------------------------|---------|
| Command frequency | [kpps] |
| Droop pulses | [pulse] |
| Servo motor speed | [r/min] |

(c) [Pr. PB28 Gain switching time constant]

You can set the primary delay filter to each gain at gain switching. This parameter is used to suppress shock given to the machine if the gain difference is large at gain switching, for example.

7. SPECIAL ADJUSTMENT FUNCTIONS

(2) Switchable gain parameter

| Loop gain | Before switching | | | After switching | | |
|---|------------------|--------|---|-----------------|--------|--|
| | Parameter | Symbol | Name | Parameter | Symbol | Name |
| Load to motor inertia ratio | PB06 | GD2 | Load to motor inertia ratio | PB29 | GD2B | Load to motor inertia ratio after gain switching |
| Model loop gain | PB07 | PG1 | Model loop gain | PB60 | PG1B | Model loop gain after gain switching |
| Position loop gain | PB08 | PG2 | Position loop gain | PB30 | PG2B | Position loop gain after gain switching |
| Speed loop gain | PB09 | VG2 | Speed loop gain | PB31 | VG2B | Speed loop gain after gain switching |
| Speed integral compensation | PB10 | VIC | Speed integral compensation | PB32 | VICB | Speed integral compensation after gain switching |
| Vibration suppression control 1 - Vibration frequency | PB19 | VRF11 | Vibration suppression control 1 - Vibration frequency | PB33 | VRF11B | Vibration suppression control 1 - Vibration frequency after gain switching |
| Vibration suppression control 1 - Resonance frequency | PB20 | VRF12 | Vibration suppression control 1 - Resonance frequency | PB34 | VRF12B | Vibration suppression control 1 - Resonance frequency after gain switching |
| Vibration suppression control 1 - Vibration frequency dumping setting | PB21 | VRF13 | Vibration suppression control 1 - Vibration frequency dumping setting | PB35 | VRF13B | Vibration suppression control 1 - Vibration frequency dumping setting after gain switching |
| Vibration suppression control 1 - Resonance frequency dumping setting | PB22 | VRF14 | Vibration suppression control 1 - Resonance frequency dumping setting | PB36 | VRF14B | Vibration suppression control 1 - Resonance frequency dumping setting after gain switching |
| Vibration suppression control 2 - Vibration frequency | PB52 | VRF21 | Vibration suppression control 2 - Vibration frequency | PB56 | VRF21B | Vibration suppression control 2 - Vibration frequency after gain switching |
| Vibration suppression control 2 - Resonance frequency | PB53 | VRF22 | Vibration suppression control 2 - Resonance frequency | PB57 | VRF22B | Vibration suppression control 2 - Resonance frequency after gain switching |
| Vibration suppression control 2 - Vibration frequency dumping setting | PB54 | VRF23 | Vibration suppression control 2 - Vibration frequency dumping setting | PB58 | VRF23B | Vibration suppression control 2 - Vibration frequency dumping setting after gain switching |
| Vibration suppression control 2 - Resonance frequency dumping setting | PB55 | VRF24 | Vibration suppression control 2 - Resonance frequency dumping setting | PB59 | VRF24B | Vibration suppression control 2 - Resonance frequency dumping setting after gain switching |

(a) [Pr. PB06] to [Pr. PB10]

These parameters are the same as in ordinary manual adjustment. Gain switching allows the values of load to motor inertia ratio, position loop gain, speed loop gain, and speed integral compensation to be switched.

(b) [Pr.PB19] to [Pr.PB22]/[Pr.PB52] to [Pr.PB55]

These parameters are the same as in ordinary manual adjustment. Executing gain switching while the servo motor stops, You can change vibration frequency, resonance frequency, vibration frequency dumping setting, and resonance frequency dumping setting.

7. SPECIAL ADJUSTMENT FUNCTIONS

- (c) [Pr. PB29 Load to motor inertia ratio after gain switching]
Set the load to motor inertia ratio after gain switching. If the load to motor inertia ratio does not change, set it to the same value as [Pr. PB06 Load to motor inertia ratio].
- (d) [Pr. PB30 Position loop gain after gain switching], [Pr. PB31 Speed loop gain after gain switching], and [Pr. PB32 Speed integral compensation after gain switching]
Set the values of after switching position loop gain, speed loop gain and speed integral compensation.
- (e) Vibration suppression control after gain switching ([Pr.PB33] to [Pr.PB36]/[Pr.PB56] to [Pr.PB59]), and [Pr. PB60 Model loop gain after gain switching]
The gain switching vibration suppression control and model loop gain are used only with input device (CDP) on/off.
You can switch the vibration frequency, resonance frequency, vibration frequency dumping setting, resonance frequency dumping setting, and model loop gain of the vibration suppression control 1 and vibration suppression control 2.

7. SPECIAL ADJUSTMENT FUNCTIONS

7.2.4 Gain switching procedure

This operation will be described by way of setting examples.

(1) When you choose switching by input device (CDP)

(a) Setting

| Parameter | Symbol | Name | Setting value | Unit |
|-----------|--------|--|--|--------------|
| PB06 | GD2 | Load to motor inertia ratio | 4.00 | [Multiplier] |
| PB07 | PG1 | Model loop gain | 100 | [rad/s] |
| PB08 | PG2 | Position loop gain | 120 | [rad/s] |
| PB09 | VG2 | Speed loop gain | 3000 | [rad/s] |
| PB10 | VIC | Speed integral compensation | 20 | [ms] |
| PB19 | VRF11 | Vibration suppression control 1 - Vibration frequency | 50 | [Hz] |
| PB20 | VRF12 | Vibration suppression control 1 - Resonance frequency | 50 | [Hz] |
| PB21 | VRF13 | Vibration suppression control 1 - Vibration frequency dumping setting | 0.20 | |
| PB22 | VRF14 | Vibration suppression control 1 - Resonance frequency dumping setting | 0.20 | |
| PB52 | VRF21 | Vibration suppression control 2 - Vibration frequency | 20 | [Hz] |
| PB53 | VRF22 | Vibration suppression control 2 - Resonance frequency | 20 | [Hz] |
| PB54 | VRF23 | Vibration suppression control 2 - Vibration frequency dumping setting | 0.10 | |
| PB55 | VRF24 | Vibration suppression control 2 - Resonance frequency dumping setting | 0.10 | |
| PB29 | GD2B | Load to motor inertia ratio after gain switching | 10.00 | [Multiplier] |
| PB60 | PG1B | Model loop gain after gain switching | 50 | [rad/s] |
| PB30 | PG2B | Position loop gain after gain switching | 84 | [rad/s] |
| PB31 | VG2B | Speed loop gain after gain switching | 4000 | [rad/s] |
| PB32 | VICB | Speed integral compensation after gain switching | 50 | [ms] |
| PB26 | CDP | Gain switching function | 0001 (Switch by input device (CDP) on/off.) | |
| PB28 | CDT | Gain switching time constant | 100 | [ms] |
| PB33 | VRF11B | Vibration suppression control 1 - Vibration frequency after gain switching | 60 | [Hz] |
| PB34 | VRF12B | Vibration suppression control 1 - Resonance frequency after gain switching | 60 | [Hz] |
| PB35 | VRF13B | Vibration suppression control 1 - Vibration frequency dumping setting after gain switching | 0.15 | |
| PB36 | VRF14B | Vibration suppression control 1 - Resonance frequency dumping setting after gain switching | 0.15 | |
| PB56 | VRF21B | Vibration suppression control 2 - Vibration frequency after gain switching | 30 | [Hz] |
| PB57 | VRF22B | Vibration suppression control 2 - Resonance frequency after gain switching | 30 | [Hz] |
| PB58 | VRF23B | Vibration suppression control 2 - Vibration frequency dumping setting after gain switching | 0.05 | |
| PB59 | VRF24B | Vibration suppression control 2 - Resonance frequency dumping setting after gain switching | 0.05 | |

7. SPECIAL ADJUSTMENT FUNCTIONS

(b) Switching timing chart

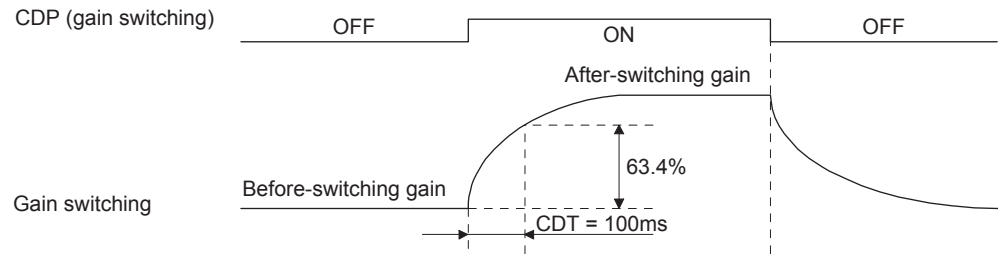

| | | | | | |
|---|------|---|-------|---|------|
| Model loop gain | 100 | → | 50 | → | 100 |
| Load to motor inertia ratio | 4.00 | → | 10.00 | → | 4.00 |
| Position loop gain | 120 | → | 84 | → | 120 |
| Speed loop gain | 3000 | → | 4000 | → | 3000 |
| Speed integral compensation | 20 | → | 50 | → | 20 |
| Vibration suppression control 1 - Vibration frequency | 50 | → | 60 | → | 50 |
| Vibration suppression control 1 - Resonance frequency | 50 | → | 60 | → | 50 |
| Vibration suppression control 1 - Vibration frequency dumping setting | 0.20 | → | 0.15 | → | 0.20 |
| Vibration suppression control 1 - Resonance frequency dumping setting | 0.20 | → | 0.15 | → | 0.20 |
| Vibration suppression control 2 - Vibration frequency | 20 | → | 30 | → | 20 |
| Vibration suppression control 2 - Resonance frequency | 20 | → | 30 | → | 20 |
| Vibration suppression control 2 - Vibration frequency dumping setting | 0.10 | → | 0.05 | → | 0.10 |
| Vibration suppression control 2 - Resonance frequency dumping setting | 0.10 | → | 0.05 | → | 0.10 |

(2) When you choose switching by droop pulses

In this case, the vibration suppression control after gain switching and model loop gain after gain switching cannot be used.

(a) Setting

| Parameter | Symbol | Name | Setting value | Unit |
|-----------|--------|--|-------------------------------------|--------------|
| PB06 | GD2 | Load to motor inertia ratio | 4.00 | [Multiplier] |
| PB08 | PG2 | Position loop gain | 120 | [rad/s] |
| PB09 | VG2 | Speed loop gain | 3000 | [rad/s] |
| PB10 | VIC | Speed integral compensation | 20 | [ms] |
| PB29 | GD2B | Load to motor inertia ratio after gain switching | 10.00 | [Multiplier] |
| PB30 | PG2B | Position loop gain after gain switching | 84 | [rad/s] |
| PB31 | VG2B | Speed loop gain after gain switching | 4000 | [rad/s] |
| PB32 | VICB | Speed integral compensation after gain switching | 50 | [ms] |
| PB26 | CDP | Gain switching selection | 0003 (switching by droop pulses) | |
| PB27 | CDL | Gain switching condition | 50 | [pulse] |
| PB28 | CDT | Gain switching time constant | 100 | [ms] |

7. SPECIAL ADJUSTMENT FUNCTIONS

(b) Switching timing chart

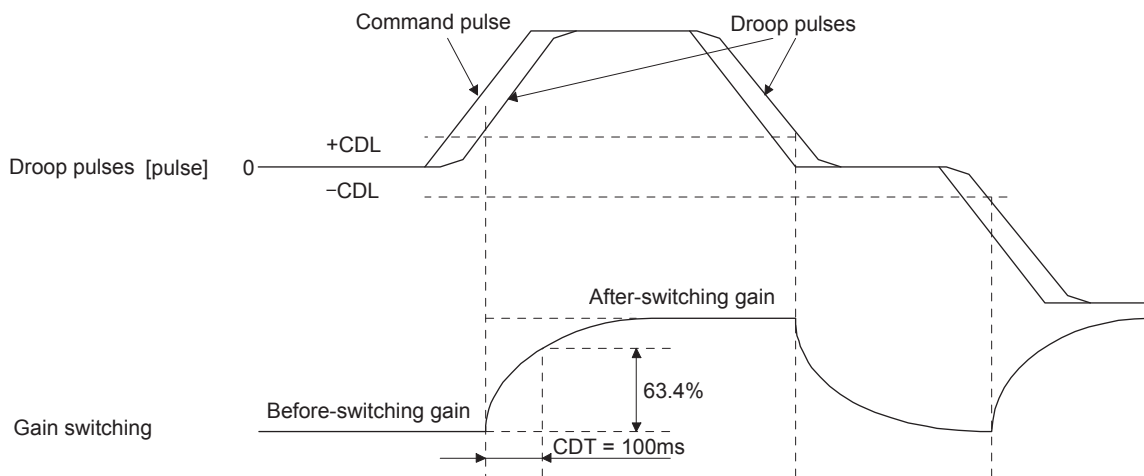

| | | | | | | | |
|-----------------------------|------|---|-------|---|------|---|-------|
| Load to motor inertia ratio | 4.00 | → | 10.00 | → | 4.00 | → | 10.00 |
| Position loop gain | 120 | → | 84 | → | 120 | → | 84 |
| Speed loop gain | 3000 | → | 4000 | → | 3000 | → | 4000 |
| Speed integral compensation | 20 | → | 50 | → | 20 | → | 50 |

7. SPECIAL ADJUSTMENT FUNCTIONS

7.3 Tough drive function

| POINT |
|---|
| ● Set enable/disable of the tough drive function with [Pr. PA20 Tough drive setting]. (Refer to section 5.2.1.) |

This function makes the equipment continue operating even under the condition that an alarm occurs.

7.3.1 Vibration tough drive function

This function prevent from vibrating by resetting a filter instantaneously when machine resonance occurs due to varied vibration frequency caused machine aging.

To reset the machine resonance suppression filters with the function, [Pr. PB13 Machine resonance suppression filter 1] and [Pr. PB15 Machine resonance suppression filter 2] should be set in advance. Set [Pr. PB13] and [Pr. PB15] as follows.

- (1) One-touch tuning execution (section 6.1)
- (2) Manual setting (section 4.2.2)

The vibration tough drive function operates when a detected machine resonance frequency is within $\pm 30\%$ for a value set in [Pr. PB13 Machine resonance suppression filter 1] or [Pr. PB15 Machine resonance suppression filter 2].

To set a detection level of the function, set sensitivity in [Pr. PF23 Vibration tough drive - Oscillation detection level].

| POINT |
|--|
| ● Resetting [Pr. PB13] and [Pr. PB15] by the vibration tough drive function is performed constantly. However, the number of write times to the EEPROM is limited to once per hour. |
| ● The vibration tough drive function does not reset [Pr. PB46 Machine resonance suppression filter 3], [Pr. PB48 Machine resonance suppression filter 4], and [Pr. PB50 Machine resonance suppression filter 5]. |

7. SPECIAL ADJUSTMENT FUNCTIONS

The following shows the function block diagram of the vibration tough drive function.

The function detects machine resonance frequency and compare it with [Pr. PB13] and [Pr. PB15], and reset a machine resonance frequency of a parameter whose set value is closer.

| Filter | Setting parameter | Precaution | Parameter that is reset with vibration tough drive function |
|--|-------------------|---|---|
| Machine resonance suppression filter 1 | PB01/PB13/PB14 | The filter can be set automatically with "Filter tuning mode selection" in [Pr. PB01]. | PB13 |
| Machine resonance suppression filter 2 | PB15/PB16 | | PB15 |
| Machine resonance suppression filter 3 | PB46/PB47 | | |
| Machine resonance suppression filter 4 | PB48/PB49 | Enabling the filter disables the shaft resonance suppression filter. The shaft resonance suppression filter is enabled for the initial setting. | |
| Machine resonance suppression filter 5 | PB50/PB51 | The setting of this filter is disabled while you use the robust filter. The robust filter is disabled for the initial setting. | |

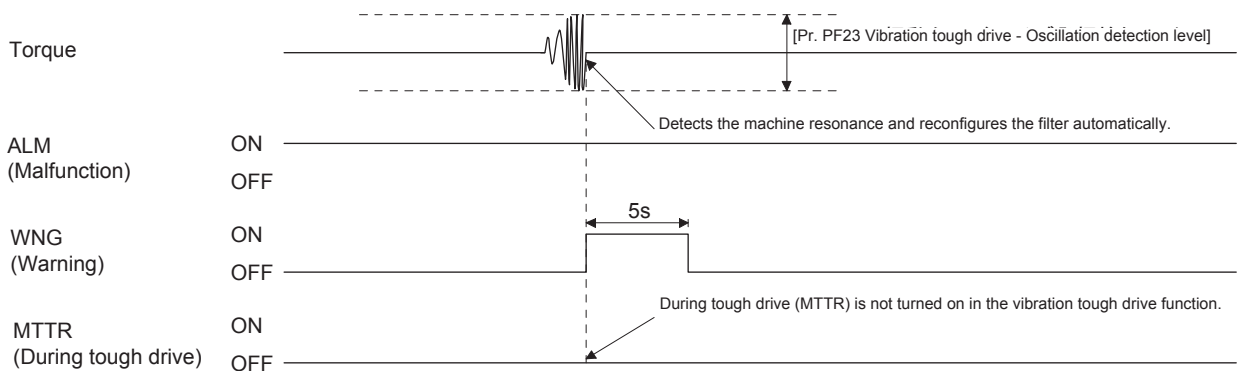
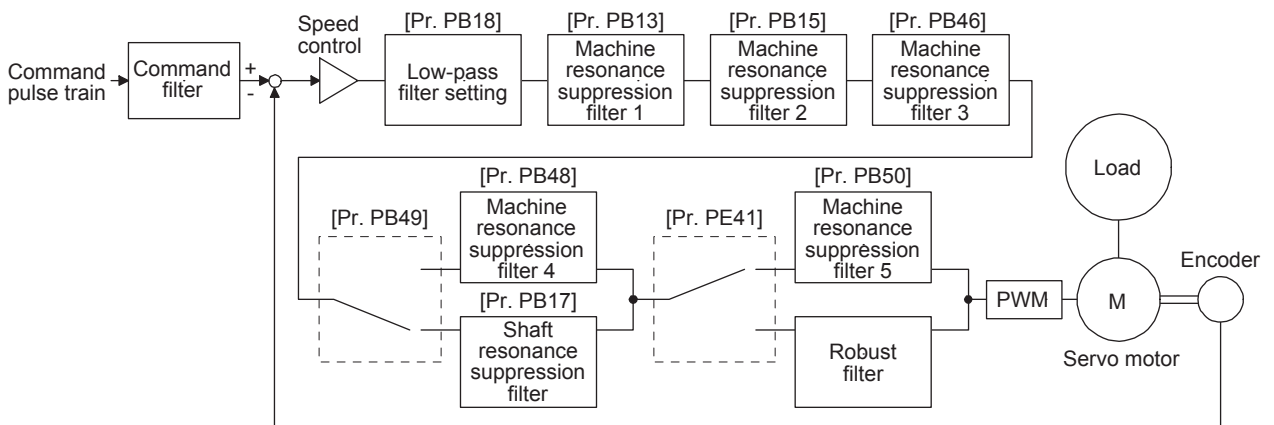

7. SPECIAL ADJUSTMENT FUNCTIONS

7.3.2 Instantaneous power failure tough drive function

| | |
|--|--|
|  CAUTION | <ul style="list-style-type: none">● During the instantaneous power failure tough drive, the torque may be limited due to the load conditions or the set value of [Pr. PF25 Instantaneous power failure tough drive - Detection time].● The immunity to instantaneous power failures is increased by the instantaneous power failure tough drive function. However, it is not compliant with the SEMI-F47 specification. |
|--|--|

The instantaneous power failure tough drive function avoids [AL. 10 Undervoltage] even when an instantaneous power failure occurs during operation. When the instantaneous power failure tough drive activates, the function will increase the immunity to instantaneous power failures using the electrical energy charged in the capacitor in the servo amplifier and will change an alarm level of [AL. 10 Undervoltage] simultaneously. The [AL. 10.1 Voltage drop in the control power] detection time for the control circuit power supply can be changed by [Pr. PF25 Instantaneous power failure tough drive - Detection time]. In addition, [AL.10.2 Voltage drop in the main circuit power] detection level for the bus voltage is changed automatically.

| |
|---|
| POINT |
| <ul style="list-style-type: none">● MBR (Electromagnetic brake interlock) will not turn off during the instantaneous power failure tough drive.● When the load of instantaneous power failure is large, the undervoltage alarm ([AL. 10.2]) caused by the bus voltage drop may occur regardless of the set value of [Pr. PF25 Instantaneous power failure tough drive - Detection time]. |

7. SPECIAL ADJUSTMENT FUNCTIONS

- (1) Instantaneous power failure time of the control circuit power supply > [Pr. PF25 Instantaneous power failure tough drive - Detection time]

The alarm occurs when the instantaneous power failure time of the control circuit power supply exceeds [Pr. PF25 Instantaneous power failure tough drive - Detection time].

MTTR (During tough drive) turns on after detecting the instantaneous power failure.

MBR (Electromagnetic brake interlock) turns off when the alarm occurs.

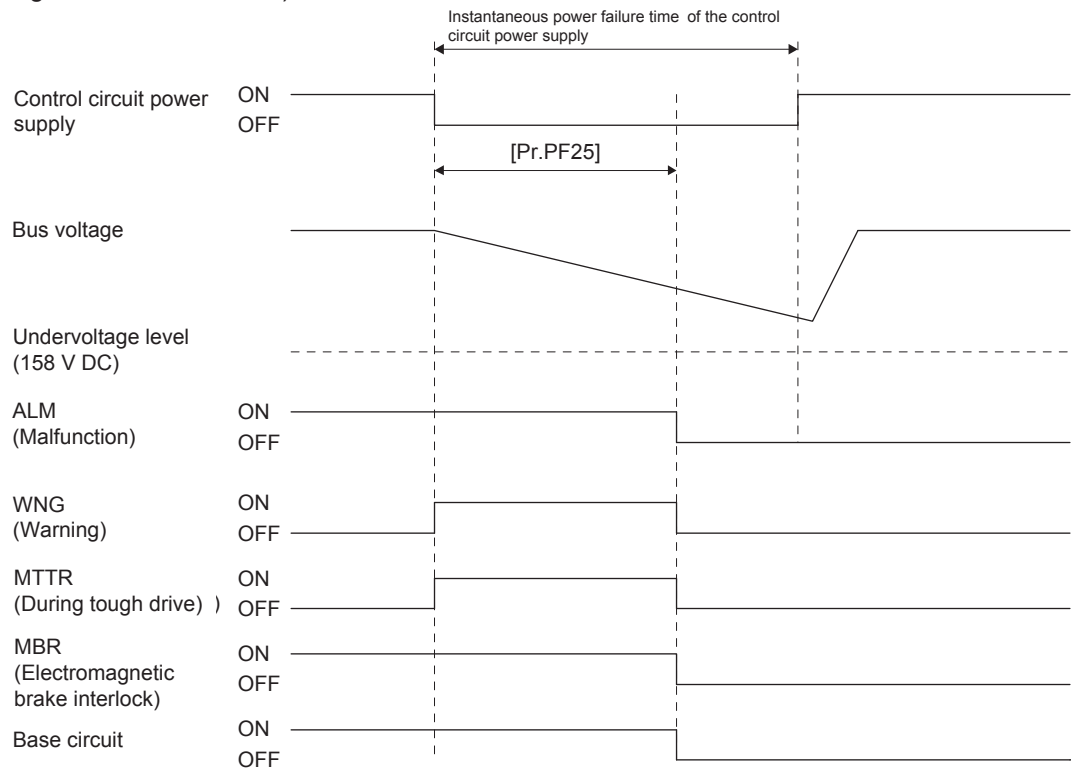

7. SPECIAL ADJUSTMENT FUNCTIONS

(2) Instantaneous power failure time of the control circuit power supply < [Pr. PF25 Instantaneous power failure tough drive - Detection time]

Operation status differs depending on how bus voltage decrease.

(a) When the bus voltage decrease lower than 158 V DC within the instantaneous power failure time of the control circuit power supply
[AL. 10 Undervoltage] occurs when the bus voltage decrease lower than 158 V DC regardless of the enabled instantaneous power failure tough drive.

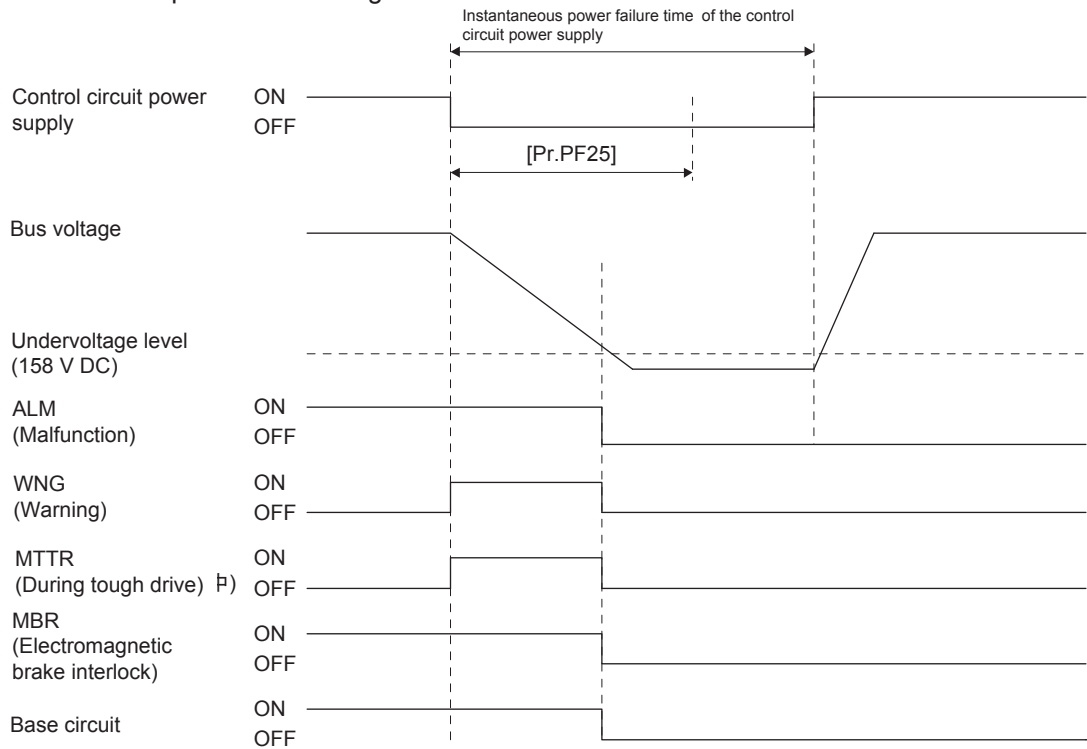

7. SPECIAL ADJUSTMENT FUNCTIONS

- (b) When the bus voltage does not decrease lower than 158 V DC within the instantaneous power failure time of the control circuit power supply
The operation continues without alarming.

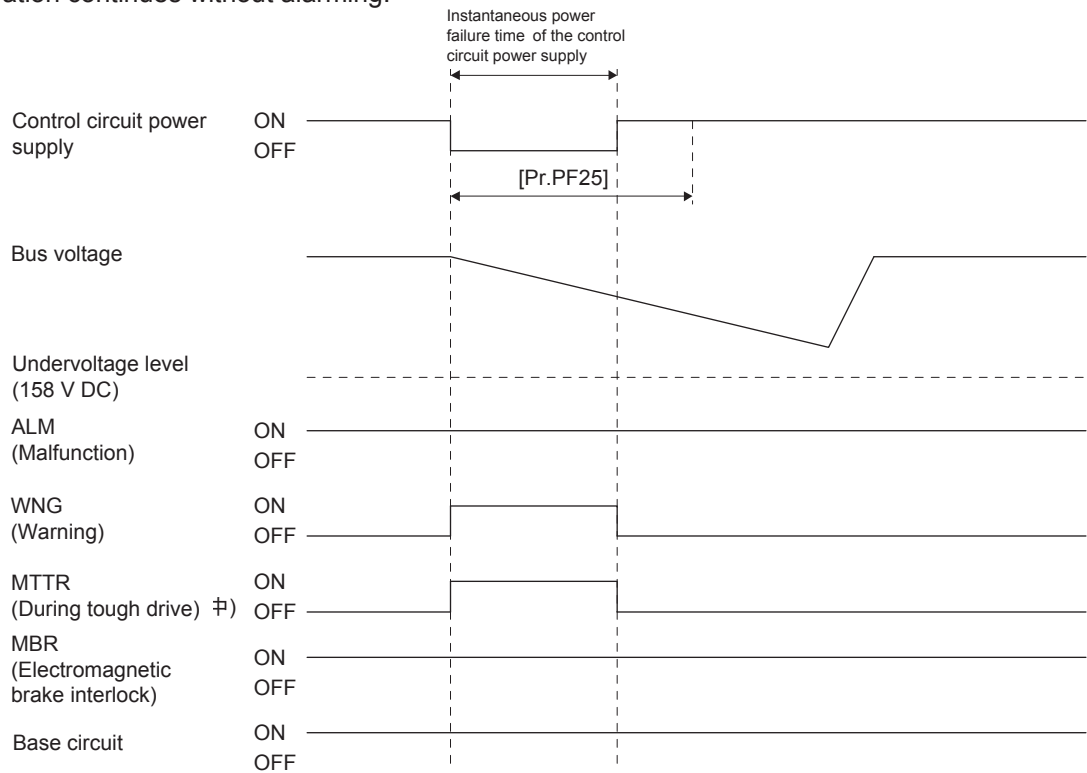

8. TROUBLESHOOTING

8. TROUBLESHOOTING

| POINT |
|---|
| <ul style="list-style-type: none"> ● Refer to MELSERVO-J4 Servo Amplifier Instruction Manual (Troubleshooting) for details of alarms and warnings. ● As soon as an alarm occurs, turn SON (Servo-on) off and interrupt the power. |

When an error occurs during operation, the corresponding alarm or warning is displayed. When the alarm or the warning occurs, refer to MELSERVO-J4 Servo Amplifier Instruction Manual (Troubleshooting) to remove the failure. When an alarm occurs, ALM will turn off.

To output alarm codes, set [Pr. PD34] to "_ _ _ 1". Alarm codes are outputted by on/off of bit 0 to bit 2. Warnings ([AL. 91] to [AL. F3]) do not have alarm codes. The alarm codes in the following table will be outputted when they occur. The alarm codes will not be outputted in normal condition.

After its cause has been removed, the alarm can be deactivated in any of the methods marked ○ in the alarm deactivation column. Warnings are automatically canceled after the cause of occurrence is removed. For the alarms and warnings written "SD" in the stop method column, the axis stops with the dynamic brake after forced stop deceleration. For the alarms and warnings written "DB" in the stop method column, the axis stops with the dynamic brake without forced stop deceleration.

Table 8.1 Alarm list

| | No. | Alarm code | | | Name | Detail display | Detail name | Stop method (Note 2, 3) | Alarm deactivation | | |
|-------|-----|----------------|----------------|----------------|--------------------------|--------------------------------|--|-------------------------|--------------------|--|----------------|
| | | CN1 22 (Bit 2) | CN1 23 (Bit 1) | CN1 24 (Bit 0) | | | | | Alarm reset (RES) | Press the "SET" button on the current alarm screen | Power off → on |
| Alarm | 10 | 0 | 1 | 0 | Undervoltage | 10.1 | Voltage drop in the control power | DB | ○ | ○ | ○ |
| | | | | | | 10.2 | Voltage drop in the main circuit power | SD | ○ | ○ | ○ |
| | 12 | 0 | 0 | 0 | Memory error 1 (RAM) | 12.1 | RAM error 1 | DB | ○ | ○ | ○ |
| | | | | | | 12.2 | RAM error 2 | DB | ○ | ○ | ○ |
| | | | | | | 12.4 | RAM error 4 | DB | ○ | ○ | ○ |
| | | | | | | 12.5 | RAM error 5 | DB | ○ | ○ | ○ |
| | 13 | 0 | 0 | 0 | Clock error | 13.1 | Clock error 1 | DB | ○ | ○ | ○ |
| | | | | | | 13.2 | Clock error 2 | DB | ○ | ○ | ○ |
| | 14 | 0 | 0 | 0 | Control process error | 14.1 | Control process error 1 | DB | ○ | ○ | ○ |
| | | | | | | 14.2 | Control process error 2 | DB | ○ | ○ | ○ |
| | | | | | | 14.3 | Control process error 3 | DB | ○ | ○ | ○ |
| | | | | | | 14.4 | Control process error 4 | DB | ○ | ○ | ○ |
| | | | | | | 14.5 | Control process error 5 | DB | ○ | ○ | ○ |
| | | | | | | 14.6 | Control process error 6 | DB | ○ | ○ | ○ |
| | | | | | | 14.7 | Control process error 7 | DB | ○ | ○ | ○ |
| | | | | | | 14.8 | Control process error 8 | DB | ○ | ○ | ○ |
| | | | | | | 14.9 | Control process error 9 | DB | ○ | ○ | ○ |
| | | | | | | 14.A | Control process error 10 | DB | ○ | ○ | ○ |
| | 15 | 0 | 0 | 0 | Memory error 2 (EEP-ROM) | 15.1 | EEP-ROM error at power on | DB | ○ | ○ | ○ |
| 15.2 | | | | | | EEP-ROM error during operation | DB | ○ | ○ | ○ | |

8. TROUBLESHOOTING

| | No. | Alarm code | | | Name | Detail display | Detail name | Stop method (Note 2, 3) | Alarm deactivation | | |
|-------|-----|----------------|----------------|----------------|---------------------------------------|----------------|---|-------------------------|--------------------|--|----------------|
| | | CN1 22 (Bit 2) | CN1 23 (Bit 1) | CN1 24 (Bit 0) | | | | | Alarm reset (RES) | Press the "SET" button on the current alarm screen | Power off → on |
| Alarm | 16 | 1 | 1 | 0 | Encoder initial communication error 1 | 16.1 | Encoder initial communication - Receive data error 1 | DB | | | ○ |
| | | | | | | 16.2 | Encoder initial communication - Receive data error 2 | DB | | | ○ |
| | | | | | | 16.3 | Encoder initial communication - Receive data error 3 | DB | | | ○ |
| | | | | | | 16.5 | Encoder initial communication - Transmission data error 1 | DB | | | ○ |
| | | | | | | 16.6 | Encoder initial communication - Transmission data error 2 | DB | | | ○ |
| | | | | | | 16.7 | Encoder initial communication - Transmission data error 3 | DB | | | ○ |
| | | | | | | 16.A | Encoder initial communication - Process error 1 | DB | | | ○ |
| | | | | | | 16.B | Encoder initial communication - Process error 2 | DB | | | ○ |
| | | | | | | 16.C | Encoder initial communication - Process error 3 | DB | | | ○ |
| | | | | | | 16.D | Encoder initial communication - Process error 4 | DB | | | ○ |
| | | | | | | 16.E | Encoder initial communication - Process error 5 | DB | | | ○ |
| | | | | | | 16.F | Encoder initial communication - Process error 6 | DB | | | ○ |
| | 17 | 0 | 0 | 0 | Board error | 17.1 | Board error 1 | DB | | | ○ |
| | | | | | | 17.3 | Board error 2 | DB | | | ○ |
| | | | | | | 17.4 | Board error 3 | DB | | | ○ |
| | 19 | 0 | 0 | 0 | Memory error 3 (Flash-ROM) | 19.1 | Flash-ROM error 1 | DB | | | ○ |
| | | | | | | 19.2 | Flash-ROM error 2 | DB | | | ○ |
| | 1A | 1 | 1 | 0 | Servo motor combination error | 1A.1 | Servo motor combination error | DB | | | ○ |
| | 1E | 1 | 1 | 0 | Encoder initial communication error 2 | 1E.1 | Encoder malfunction | DB | | | ○ |
| | 1F | 1 | 1 | 0 | Encoder initial communication error 3 | 1F.1 | Incompatible encoder | DB | | | ○ |
| | 20 | 1 | 1 | 0 | Encoder normal communication error 1 | 20.1 | Encoder normal communication - Receive data error 1 | DB | | | ○ |
| | | | | | | 20.2 | Encoder normal communication - Receive data error 2 | DB | | | ○ |
| | | | | | | 20.3 | Encoder normal communication - Receive data error 3 | DB | | | ○ |
| | | | | | | 20.5 | Encoder normal communication - Transmission data error 1 | DB | | | ○ |
| | | | | | | 20.6 | Encoder normal communication - Transmission data error 2 | DB | | | ○ |
| | | | | | | 20.7 | Encoder normal communication - Transmission data error 3 | DB | | | ○ |
| | | | | | | 20.9 | Encoder normal communication - Receive data error 4 | DB | | | ○ |
| | | | | | | 20.A | Encoder normal communication - Receive data error 5 | DB | | | ○ |

8. TROUBLESHOOTING

| | No. | Alarm code | | | Name | Detail display | Detail name | Stop method (Note 2, 3) | Alarm deactivation | | |
|-------|-----|----------------|----------------|----------------|--|----------------|--|-------------------------|-----------------------------------|--|-----------------------------------|
| | | CN1 22 (Bit 2) | CN1 23 (Bit 1) | CN1 24 (Bit 0) | | | | | Alarm reset (RES) | Press the "SET" button on the current alarm screen | Power off → on |
| Alarm | 21 | 1 | 1 | 0 | Encoder normal communication error 2 | 21.1 | Encoder data error 1 | DB | <input type="checkbox"/> | <input type="checkbox"/> | <input type="checkbox"/> |
| | | | | | | 21.2 | Encoder data update error | DB | <input type="checkbox"/> | <input type="checkbox"/> | <input type="checkbox"/> |
| | | | | | | 21.3 | Encoder data waveform error | DB | <input type="checkbox"/> | <input type="checkbox"/> | <input type="checkbox"/> |
| | | | | | | 21.5 | Encoder hardware error 1 | DB | <input type="checkbox"/> | <input type="checkbox"/> | <input type="checkbox"/> |
| | | | | | | 21.6 | Encoder hardware error 2 | DB | <input type="checkbox"/> | <input type="checkbox"/> | <input type="checkbox"/> |
| | | | | | | 21.9 | Encoder data error 2 | DB | <input type="checkbox"/> | <input type="checkbox"/> | <input type="checkbox"/> |
| | 24 | 1 | 0 | 0 | Main circuit error | 24.1 | Ground fault detected by hardware detection circuit | DB | <input type="checkbox"/> | <input type="checkbox"/> | <input type="checkbox"/> |
| | | | | | | 24.2 | Ground fault detected by software detection function | DB | <input type="checkbox"/> | <input type="checkbox"/> | <input type="checkbox"/> |
| | 25 | 1 | 1 | 0 | Absolute position erased | 25.1 | Servo motor encoder - Absolute position erased | DB | <input type="checkbox"/> | <input type="checkbox"/> | <input type="checkbox"/> |
| | 30 | 0 | 0 | 1 | Regenerative error (Note 1) | 30.1 | Regeneration heat error | DB | <input type="checkbox"/> (Note 1) | <input type="checkbox"/> (Note 1) | <input type="checkbox"/> (Note 1) |
| | | | | | | 30.2 | Regeneration signal error | DB | <input type="checkbox"/> (Note 1) | <input type="checkbox"/> (Note 1) | <input type="checkbox"/> (Note 1) |
| | | | | | | 30.3 | Regeneration feedback signal error | DB | <input type="checkbox"/> (Note 1) | <input type="checkbox"/> (Note 1) | <input type="checkbox"/> (Note 1) |
| | 31 | 1 | 0 | 1 | Overspeed | 31.1 | Abnormal motor speed | SD | <input type="checkbox"/> | <input type="checkbox"/> | <input type="checkbox"/> |
| | 32 | 1 | 0 | 0 | Overcurrent | 32.1 | Overcurrent detected at hardware detection circuit (during operation) | DB | <input type="checkbox"/> | <input type="checkbox"/> | <input type="checkbox"/> |
| | | | | | | 32.2 | Overcurrent detected at software detection function (during operation) | DB | <input type="checkbox"/> | <input type="checkbox"/> | <input type="checkbox"/> |
| | | | | | | 32.3 | Overcurrent detected at hardware detection circuit (during a stop) | DB | <input type="checkbox"/> | <input type="checkbox"/> | <input type="checkbox"/> |
| | | | | | | 32.4 | Overcurrent detected at software detection function (during a stop) | DB | <input type="checkbox"/> | <input type="checkbox"/> | <input type="checkbox"/> |
| | 33 | 0 | 0 | 1 | Overvoltage | 33.1 | Main circuit voltage error | DB | <input type="checkbox"/> | <input type="checkbox"/> | <input type="checkbox"/> |
| | 35 | 1 | 0 | 1 | Command frequency error | 35.1 | Command frequency error | SD | <input type="checkbox"/> | <input type="checkbox"/> | <input type="checkbox"/> |
| | 37 | 0 | 0 | 0 | Parameter error | 37.1 | Parameter setting range error | DB | <input type="checkbox"/> | <input type="checkbox"/> | <input type="checkbox"/> |
| | | | | | | 37.2 | Parameter combination error | DB | <input type="checkbox"/> | <input type="checkbox"/> | <input type="checkbox"/> |
| | 3A | 0 | 0 | 0 | Inrush current suppression circuit error | 3A.1 | Inrush current suppression circuit error | DB | <input type="checkbox"/> | <input type="checkbox"/> | <input type="checkbox"/> |
| | 45 | 0 | 1 | 1 | Main circuit device overheat (Note 1) | 45.1 | Main circuit device overheat error | SD | <input type="checkbox"/> (Note 1) | <input type="checkbox"/> (Note 1) | <input type="checkbox"/> (Note 1) |
| | 46 | 0 | 1 | 1 | Servo motor overheat (Note 1) | 46.1 | Abnormal temperature of servo motor 1 | SD | <input type="checkbox"/> (Note 1) | <input type="checkbox"/> (Note 1) | <input type="checkbox"/> (Note 1) |
| | | | | | | 46.5 | Abnormal temperature of servo motor 3 | DB | <input type="checkbox"/> (Note 1) | <input type="checkbox"/> (Note 1) | <input type="checkbox"/> (Note 1) |
| | | | | | | 46.6 | Abnormal temperature of servo motor 4 | DB | <input type="checkbox"/> (Note 1) | <input type="checkbox"/> (Note 1) | <input type="checkbox"/> (Note 1) |

8. TROUBLESHOOTING

| | No. | Alarm code | | | Name | Detail display | Detail name | Stop method (Note 2, 3) | Alarm deactivation | | |
|-------|-----|----------------|----------------|----------------------------------|-----------------------|-------------------------------------|--|-------------------------|--------------------|--|----------------|
| | | CN1 22 (Bit 2) | CN1 23 (Bit 1) | CN1 24 (Bit 0) | | | | | Alarm reset (RES) | Press the "SET" button on the current alarm screen | Power off → on |
| Alarm | 47 | 0 | 1 | 1 | Cooling fan error | 47.1 | Cooling fan stop error | SD | | | ○ |
| | | | | | | 47.2 | Cooling fan speed reduction error | SD | | | ○ |
| | 50 | 0 | 1 | 1 | Overload 1 (Note 1) | 50.1 | Thermal overload error 1 during operation | SD | ○ (Note 1) | ○ (Note 1) | ○ (Note 1) |
| | | | | | | 50.2 | Thermal overload error 2 during operation | SD | ○ (Note 1) | ○ (Note 1) | ○ (Note 1) |
| | | | | | | 50.3 | Thermal overload error 4 during operation | SD | ○ (Note 1) | ○ (Note 1) | ○ (Note 1) |
| | | | | | | 50.4 | Thermal overload error 1 during a stop | SD | ○ (Note 1) | ○ (Note 1) | ○ (Note 1) |
| | | | | | | 50.5 | Thermal overload error 2 during a stop | SD | ○ (Note 1) | ○ (Note 1) | ○ (Note 1) |
| | | | | | | 50.6 | Thermal overload error 4 during a stop | SD | ○ (Note 1) | ○ (Note 1) | ○ (Note 1) |
| | 51 | 0 | 1 | 1 | Overload 2 (Note 1) | 51.1 | Thermal overload error 3 during operation | DB | ○ (Note 1) | ○ (Note 1) | ○ (Note 1) |
| | | | | | | 51.2 | Thermal overload error 3 during a stop | DB | ○ (Note 1) | ○ (Note 1) | ○ (Note 1) |
| | 52 | 1 | 0 | 1 | Error excessive | 52.1 | Excess droop pulse 1 | SD | ○ | ○ | ○ |
| | | | | | | 52.3 | Excess droop pulse 2 | SD | ○ | ○ | ○ |
| | | | | | | 52.4 | Error excessive during 0 torque limit | SD | ○ | ○ | ○ |
| | | | | | | 52.5 | Excess droop pulse 3 | DB | ○ | ○ | ○ |
| | 54 | 0 | 1 | 1 | Oscillation detection | 54.1 | Oscillation detection error | DB | ○ | ○ | ○ |
| | | | | | | 56.2 | Over speed during forced stop | DB | ○ | ○ | ○ |
| | 56 | 1 | 1 | 0 | Forced stop error | 56.3 | Estimated distance over during forced stop | DB | ○ | ○ | ○ |
| | | | | | | 63.1 | STO1 off | DB | ○ | ○ | ○ |
| | 63 | 1 | 1 | 0 | STO timing error | 63.2 | STO2 off | DB | ○ | ○ | ○ |
| | | | | | | 8A.1 | USB communication time-out error | SD | ○ | ○ | ○ |
| 8A | 0 | 0 | 0 | USB communication time-out error | 8A.1 | USB communication time-out error | SD | ○ | ○ | ○ | |
| 8E | 0 | 0 | 0 | USB communication error | 8E.1 | USB communication receive error | SD | ○ | ○ | ○ | |
| | | | | | 8E.2 | USB communication checksum error | SD | ○ | ○ | ○ | |
| | | | | | 8E.3 | USB communication character error | SD | ○ | ○ | ○ | |
| | | | | | 8E.4 | USB communication command error | SD | ○ | ○ | ○ | |
| | | | | | 8E.5 | USB communication data number error | SD | ○ | ○ | ○ | |
| 88888 | | | | Watchdog | 8888_ | Watchdog | SD | | | ○ | |

Note 1. Leave for about 30 minutes of cooling time after removing the cause of occurrence.

2. Stop method indicates as follows:

DB: Stops with dynamic brake. (Coasts for the servo amplifier without dynamic brake.)

SD: Forced stop deceleration

3. This is applicable when [Pr. PA04] is set to the initial value. The stop system of SD can be changed to DB using [Pr. PA04].

8. TROUBLESHOOTING

Table 8.2 Warning list

| No. | Name | Detail display | Detail name | Stop method (Note 2, 3) |
|---------|-------------------------------------|--|--|-------------------------|
| Warning | 91 | Servo amplifier overheat warning (Note 1) | 91.1 Main circuit device overheat warning | |
| | 92 | Battery cable disconnection warning | 92.1 Encoder battery cable disconnection warning | |
| | | | 92.3 Battery degradation | |
| | 95 | STO warning | 95.1 STO1 off detection | DB |
| | | | 95.2 STO2 off detection | DB |
| | 96 | Home position setting warning | 96.1 In-position warning at home positioning | |
| | | | 96.2 Command input warning at home positioning | |
| | | | 96.3 Servo off warning at home positioning | |
| | 99 | Stroke limit warning | 99.1 Forward rotation stroke limit off | (Note 4) |
| | | | 99.2 Reverse rotation stroke limit off | (Note 4) |
| | 9F | Battery warning | 9F.1 Low battery | |
| | E0 | Excessive regeneration warning (Note 1) | E0.1 Excessive regeneration warning | |
| | E1 | Overload warning (Note 1) | E1.1 Thermal overload warning 1 during operation | |
| | | | E1.2 Thermal overload warning 2 during operation | |
| | | | E1.3 Thermal overload warning 3 during operation | |
| | | | E1.4 Thermal overload warning 4 during operation | |
| | | | E1.5 Thermal overload error 1 during a stop | |
| | | | E1.6 Thermal overload error 2 during a stop | |
| | | | E1.7 Thermal overload error 3 during a stop | |
| | | | E1.8 Thermal overload error 4 during a stop | |
| | E3 | Absolute position counter warning | E3.1 Multi-revolution counter travel distance excess warning | |
| | | | E3.2 Encoder absolute positioning counter warning | |
| | | | E3.5 Absolute position counter warning | |
| | E5 | ABS time-out warning | E5.1 Time-out during ABS data transfer | |
| | | | E5.2 ABSM off during ABS data transfer | |
| | | | E5.3 SON off during ABS data transfer | |
| | E6 | Servo forced stop warning | E6.1 Forced stop warning | SD |
| | E8 | Cooling fan speed reduction warning | E8.1 Decreased cooling fan speed warning | |
| | E9 | Main circuit off warning | E9.1 Servo-on signal on during main circuit off | DB |
| | | | E9.2 Bus voltage drop during low speed operation | DB |
| EA | ABS servo-on warning | EA.1 ABS servo-on warning | | |
| EC | Overload warning 2 (Note 1) | EC.1 Overload warning 2 | | |
| ED | Output watt excess warning | ED.1 Output watt excess warning | | |
| F0 | Tough drive warning | F0.1 Instantaneous power failure tough drive warning | | |
| | | F0.3 Vibration tough drive warning | | |
| F2 | Drive recorder - Miswriting warning | F2.1 Drive recorder - Area writing time-out warning | | |
| | | F2.2 Drive recorder - Data miswriting warning | | |
| F3 | Oscillation detection warning | F3.1 Oscillation detection warning | | |

Note 1. Leave for about 30 minutes of cooling time after removing the cause of occurrence.

2. Stop method indicates as follows:

DB: Stops with dynamic brake. (Coasts for the servo amplifier without dynamic brake.)

SD: Forced stop deceleration

3. This is applicable when [Pr. PA04] is set to the initial value. The stop system of SD can be changed to DB using [Pr. PA04].

4. Quick stop or slow stop can be selected using [Pr. PD30].

9. OUTLINE DRAWINGS

9. OUTLINE DRAWINGS

9.1 Servo amplifier

(1) MR-J4-10A•MR-J4-20A

[Unit: mm]

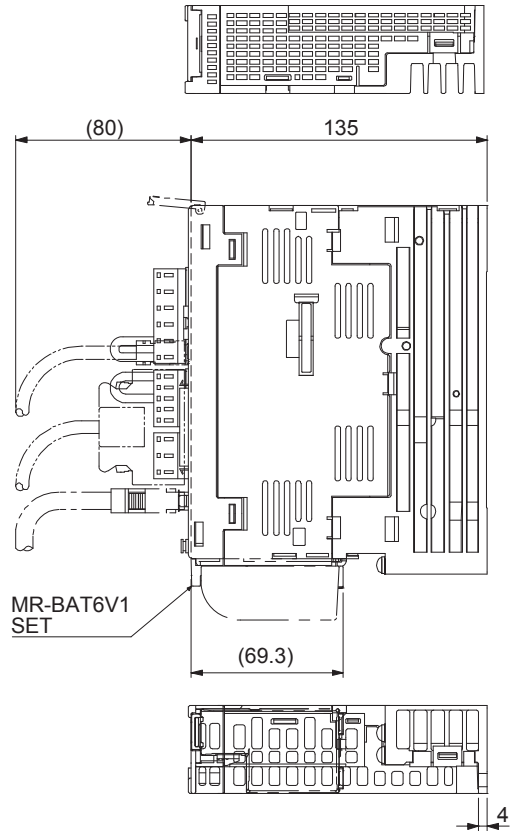
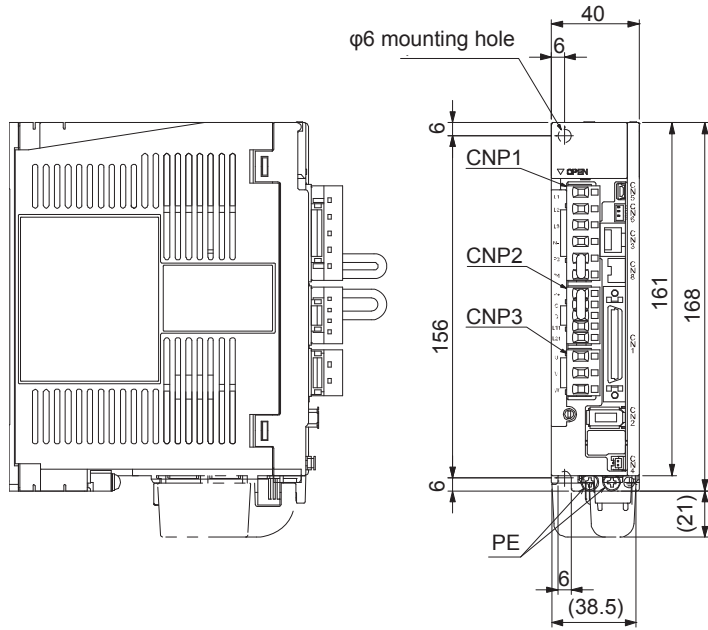

Mass: 0.8[kg]

Mounting screw
Screw size: M5
Tightening torque: 3.24[N•m]

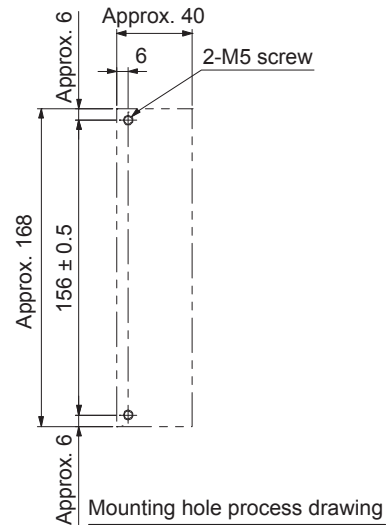
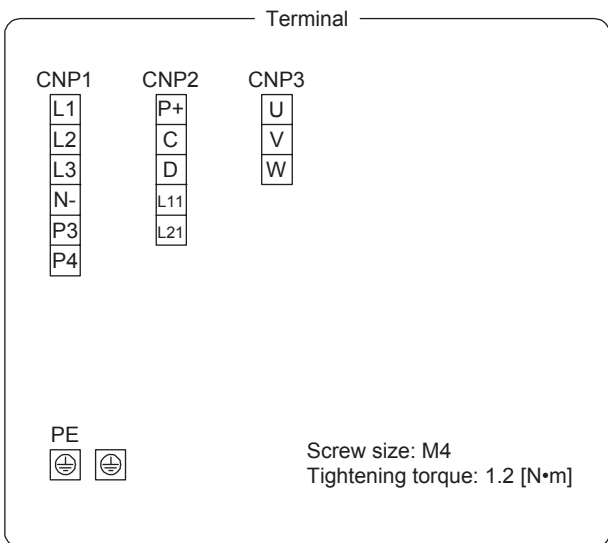

9. OUTLINE DRAWINGS

(2) MR-J4-40A•MR-J4-60A

[Unit: mm]

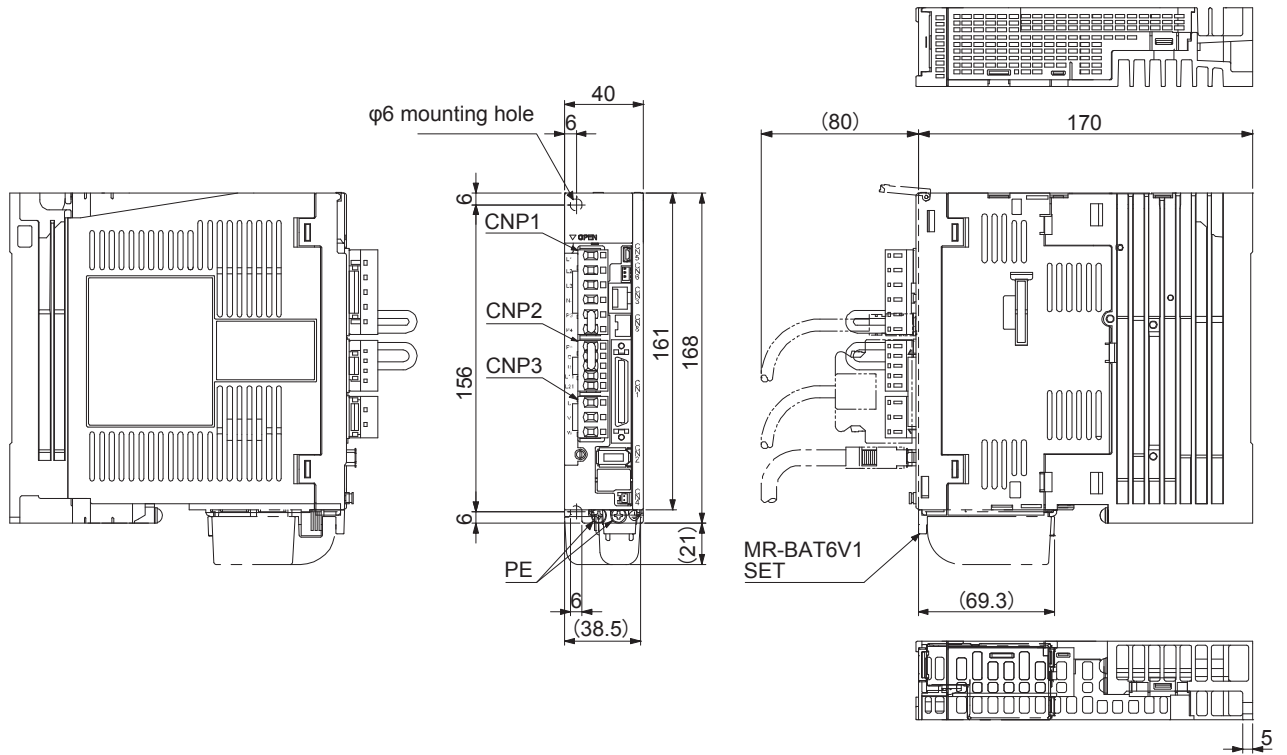

Mass: 1.0[kg]

Mounting screw
Screw size: M5
Tightening torque: 3.24[N•m]

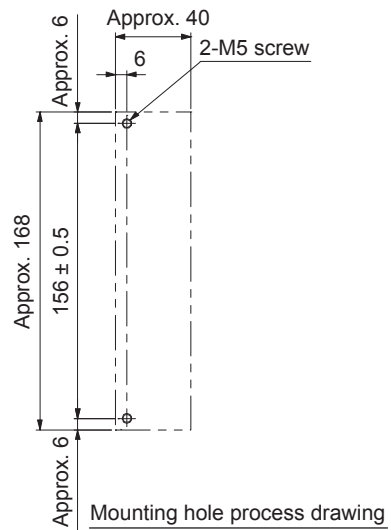
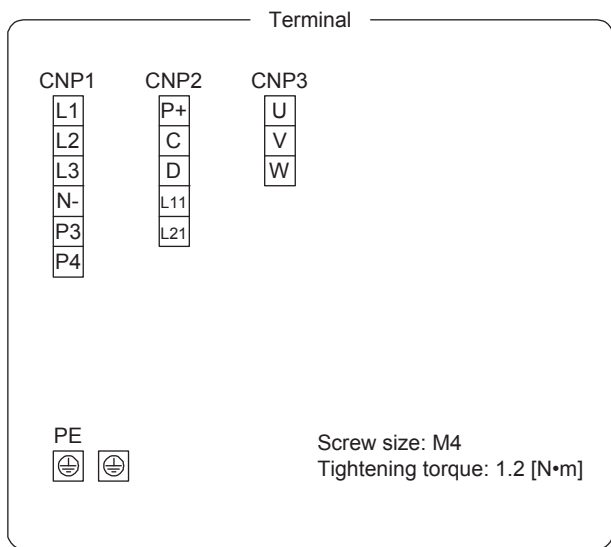

9. OUTLINE DRAWINGS

(3) MR-J4-70A•MR-J4-100A

[単位: mm]

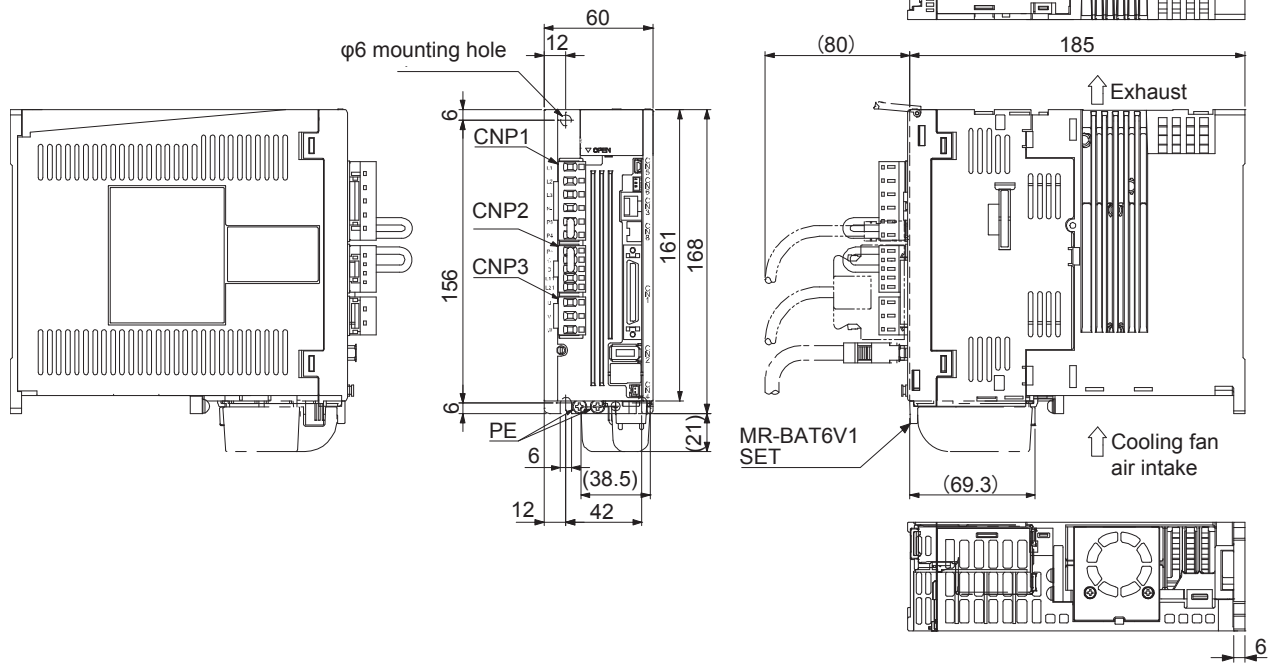

Mass: 1.4[kg]

Mounting screw

Screw size: M5

Tightening torque: 3.24[N•m]

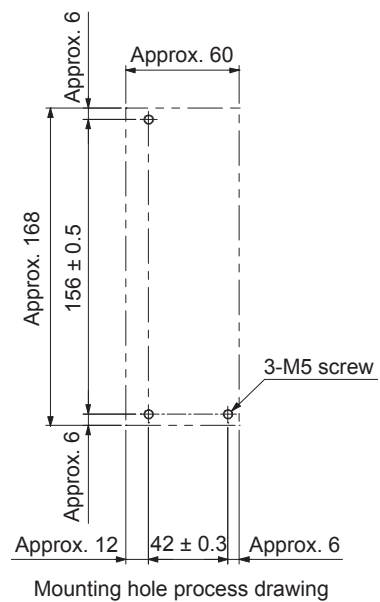
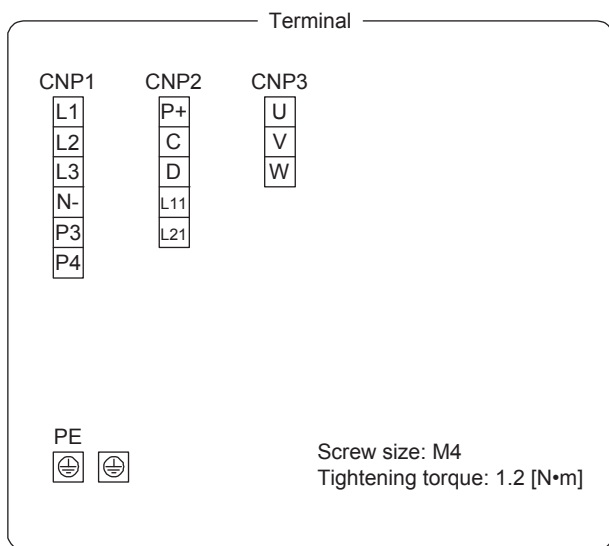

9. OUTLINE DRAWINGS

(4) MR-J4-200A

[Unit: mm]

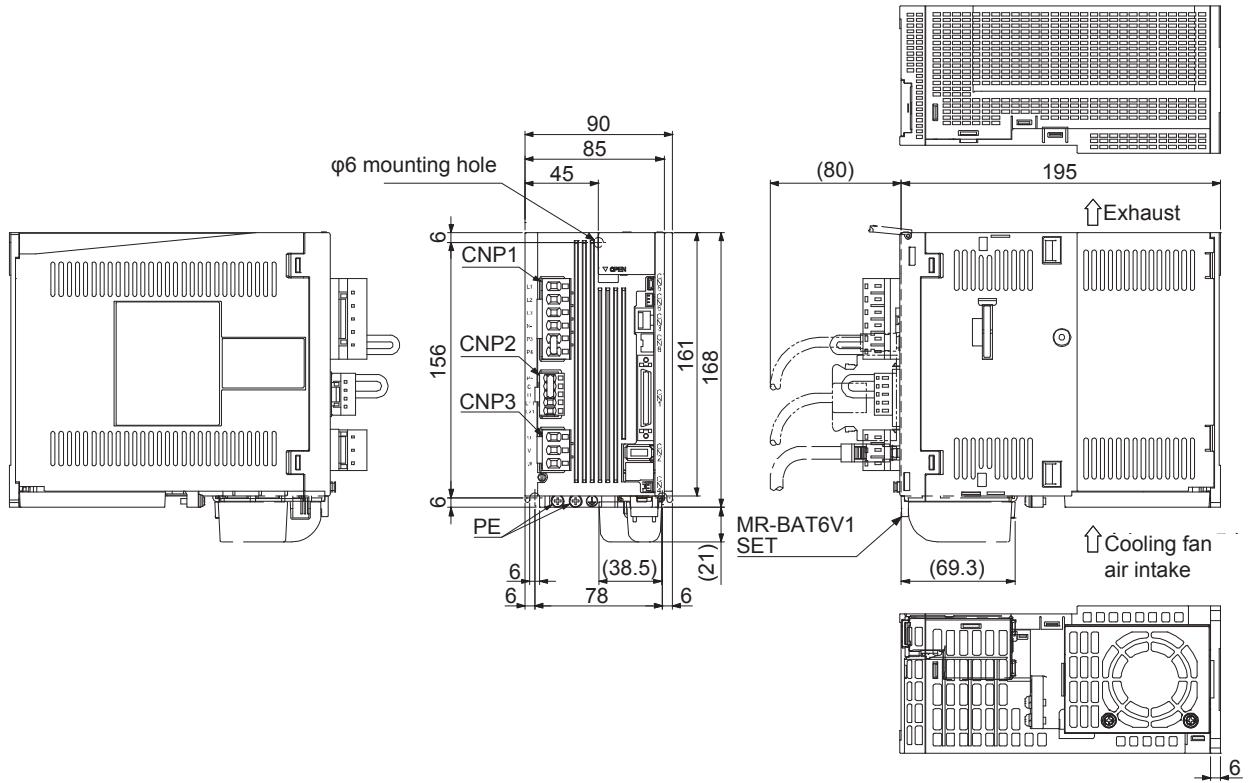

Mass: 2.1[kg]

Mounting screw
Screw size: M5
Tightening torque: 3.24[N·m]

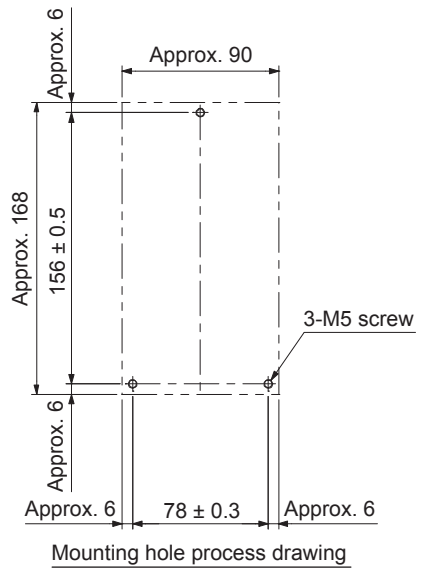
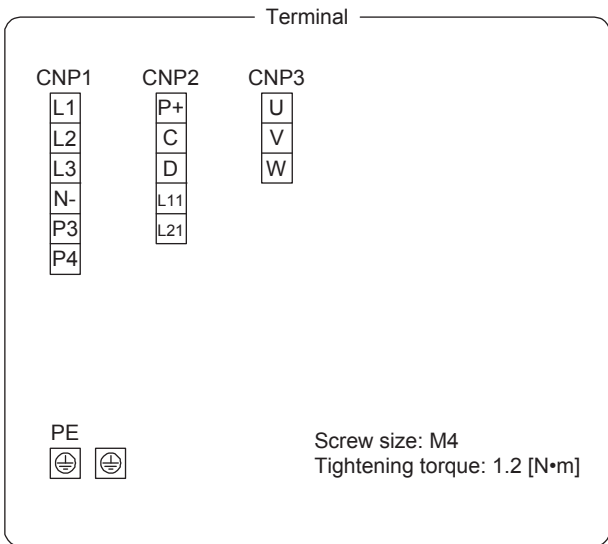

9. OUTLINE DRAWINGS

(5) MR-J4-350A

[Unit: mm]

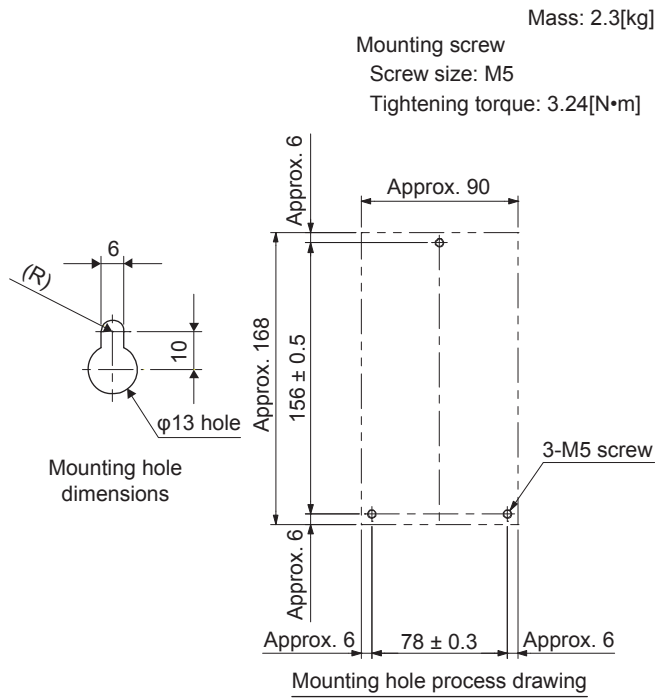
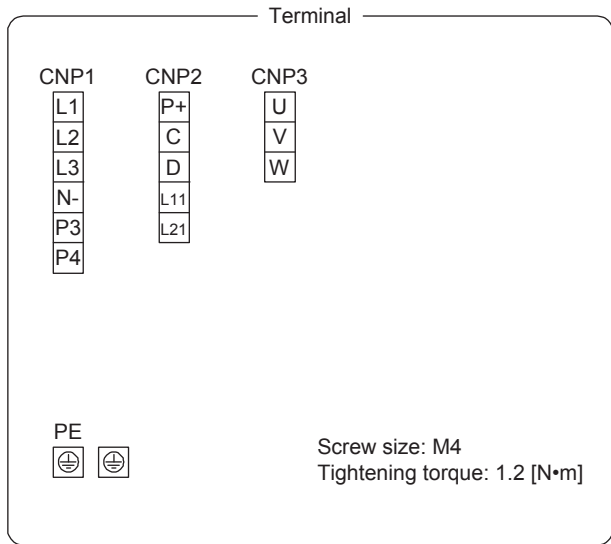
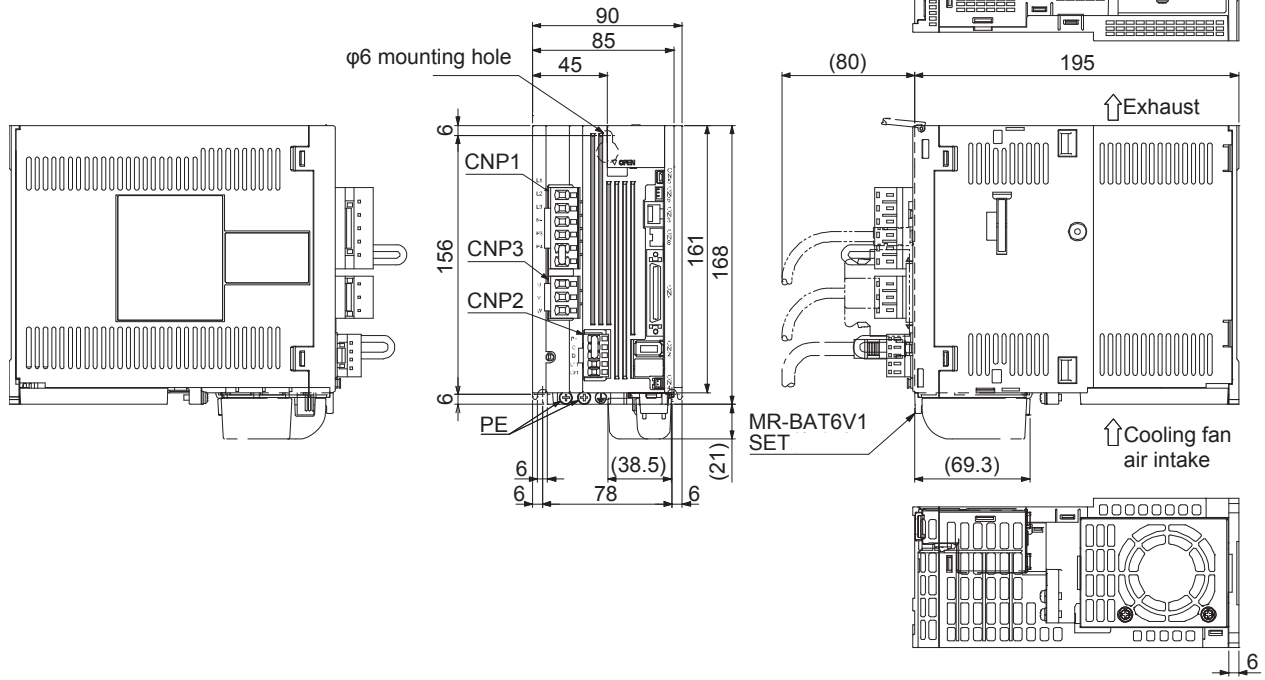

9. OUTLINE DRAWINGS

(6) MR-J4-500A

[Unit: mm]

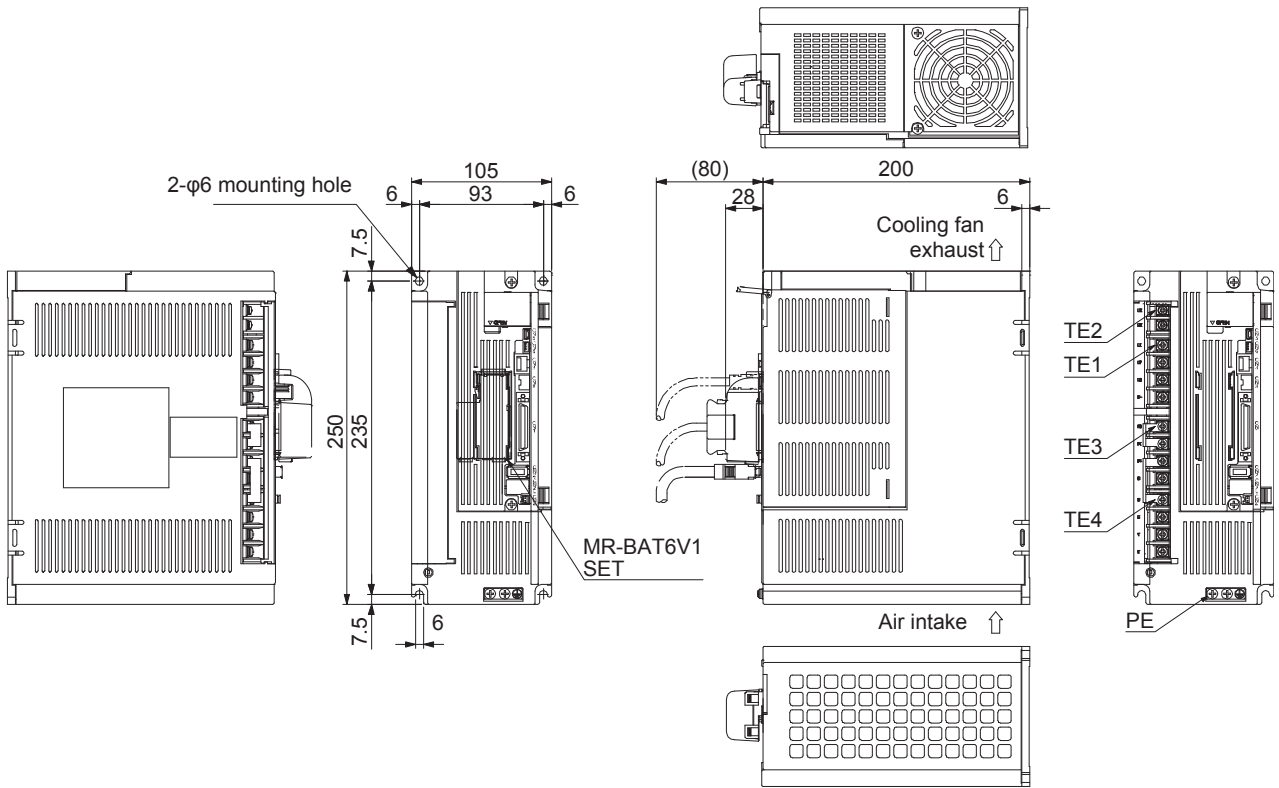

Mass: 4.6[kg]

Mounting screw
Screw size M5
Tightening torque: 3.24[N•m]

| Terminal | | |
|----------|----------------------|--|
| TE2 | L11 L21 | TE2 Screw size: M3.5 Tightening torque: 0.8 [N•m] |
| TE1 | L1 L2 L3 N- | TE1 Screw size: M4 Tightening torque: 1.2 [N•m] |
| TE3 | P3 P4 P+ C | TE3 Screw size: M4 Tightening torque: 1.2 [N•m] |
| TE4 | D U V W | TE4 Screw size: M4 Tightening torque: 1.2 [N•m] |
| | PE | PE Screw size: M4 Tightening torque: 1.2 [N•m] |

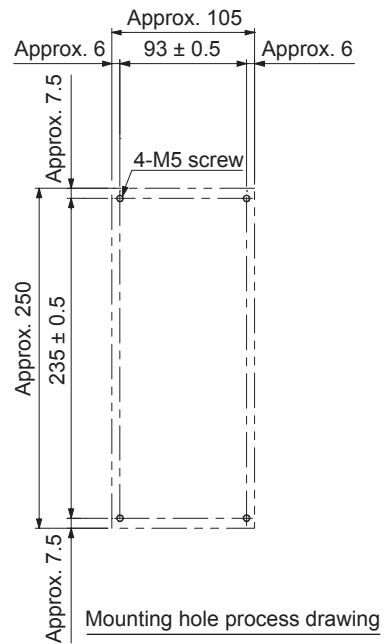

Mounting hole process drawing

9. OUTLINE DRAWINGS

(7) MR-J4-700A

[Unit: mm]

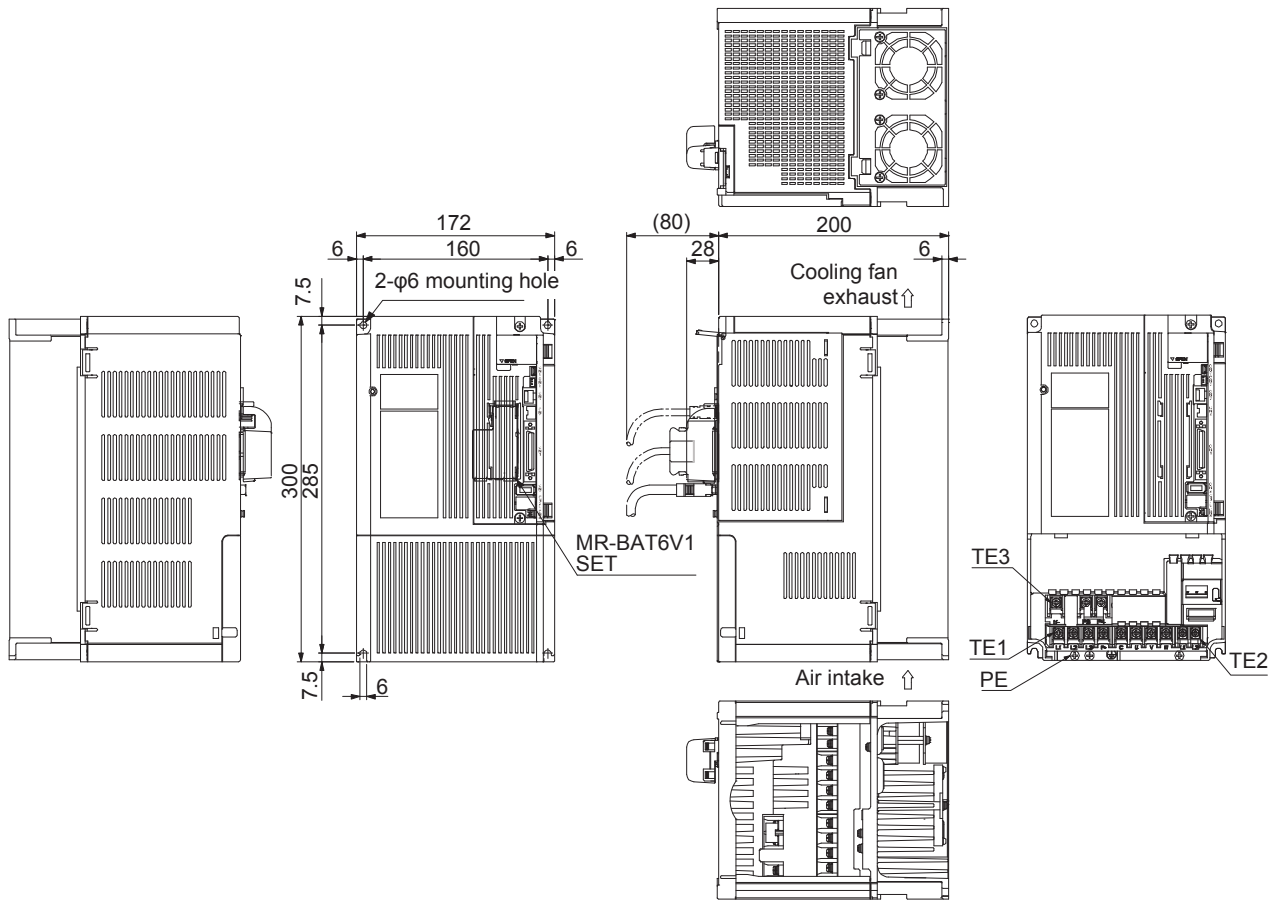

Mass: 6.2[kg]

Mounting screw
Screw size: M5
Tightening torque: 3.24[N•m]

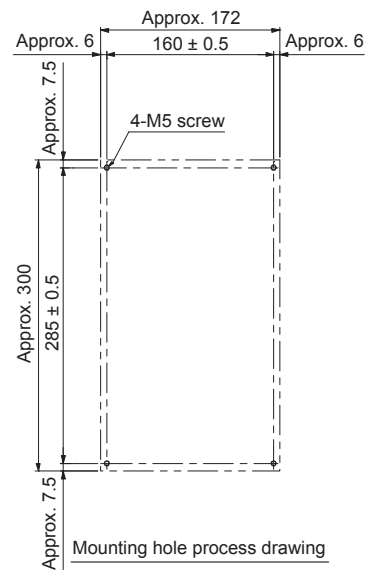
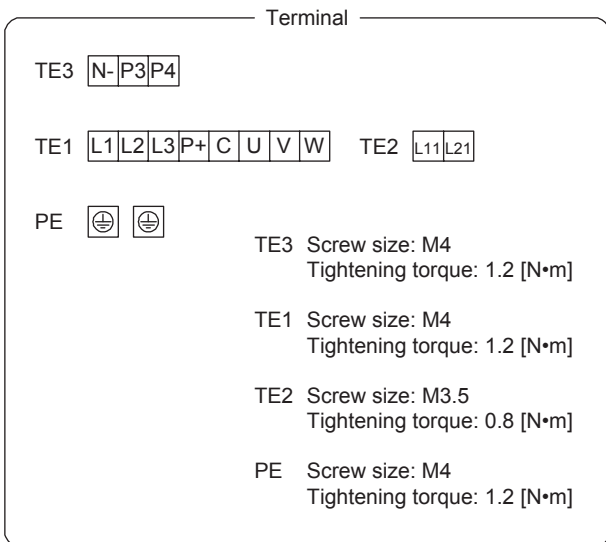

9. OUTLINE DRAWINGS

9.2 Connector

(1) Miniature delta ribbon (MDR) system (3M)

(a) One-touch lock type

[Unit: mm]

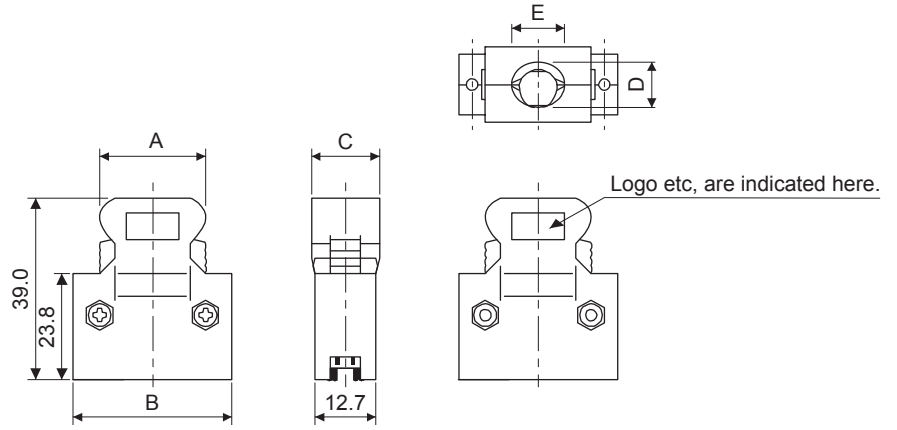

| Connector | Shell kit | Each type of dimension | | | | |
|--------------|----------------|------------------------|------|------|------|------|
| | | A | B | C | D | E |
| 10150-3000PE | 10350-52F0-008 | 41.1 | 52.4 | 18.0 | 14.0 | 17.0 |

(b) Jack screw M2.6 type

This is not available as option.

[Unit: mm]

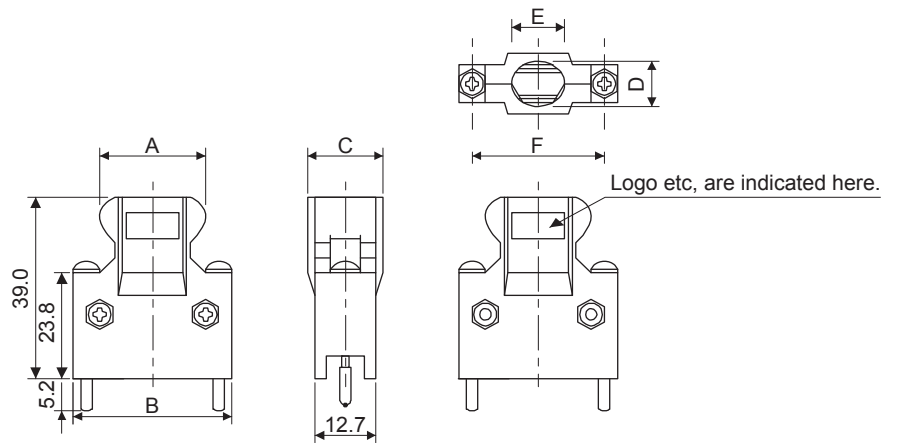

| Connector | Shell kit | Each type of dimension | | | | | |
|--------------|----------------|------------------------|------|------|------|------|------|
| | | A | B | C | D | E | F |
| 10150-3000PE | 10350-52A0-008 | 41.1 | 52.4 | 18.0 | 14.0 | 17.0 | 46.5 |

9. OUTLINE DRAWINGS

- (2) SCR connector system (3M)
Receptacle : 36210-0100PL
Shell kit : 36310-3200-008

[Unit: mm]

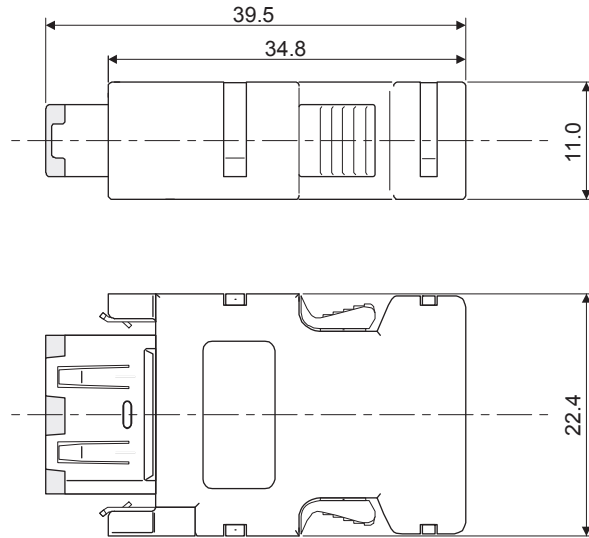

10. CHARACTERISTICS

10. CHARACTERISTICS

10.1 Overload protection characteristics

An electronic thermal is built in the servo amplifier to protect the servo motor, servo amplifier and servo motor power wires from overloads.

[AL. 50 Overload 1] occurs if overload operation performed is above the electronic thermal protection curve shown in fig. 10.1 [AL. 51 Overload 2] occurs if the maximum current is applied continuously for several seconds due to machine collision, etc. Use the equipment on the left-hand side area of the continuous or broken line in the graph.

When unbalanced torque is generated, such as in a vertical lift machine, it is recommended that the unbalanced torque of the machine be kept at 70% or less of the motor's rated torque.

This servo amplifier has solid-state servo motor overload protection. (The servo motor overload current (full load current) is set on the basis of 120% rated current of the servo amplifier.)

10. CHARACTERISTICS

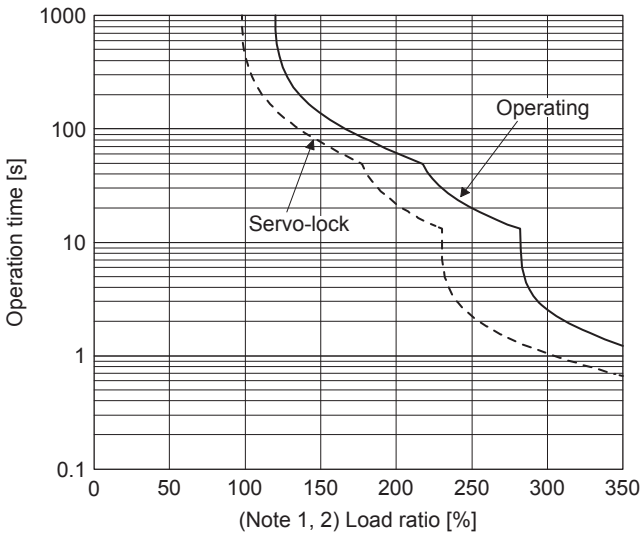

HG-KR053, HG-KR13
HG-MR053, HG-MR13

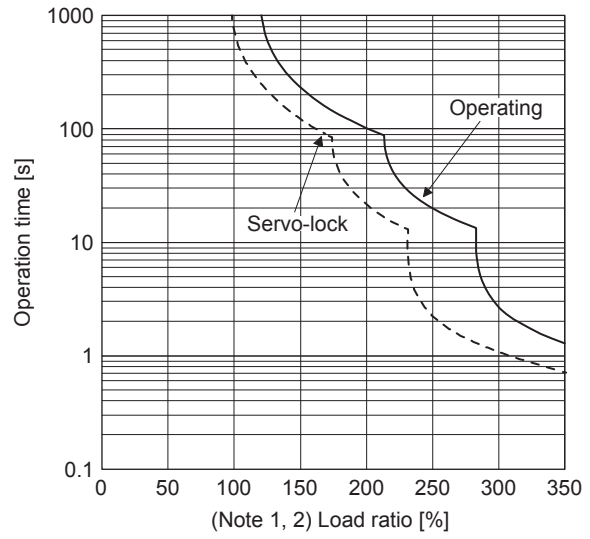

HG-KR23, HG-KR43, HG-KR73
HG-MR23, HG-MR43, HG-MR73
HG-SR51, HG-SR81, HG-SR52, HG-SR102

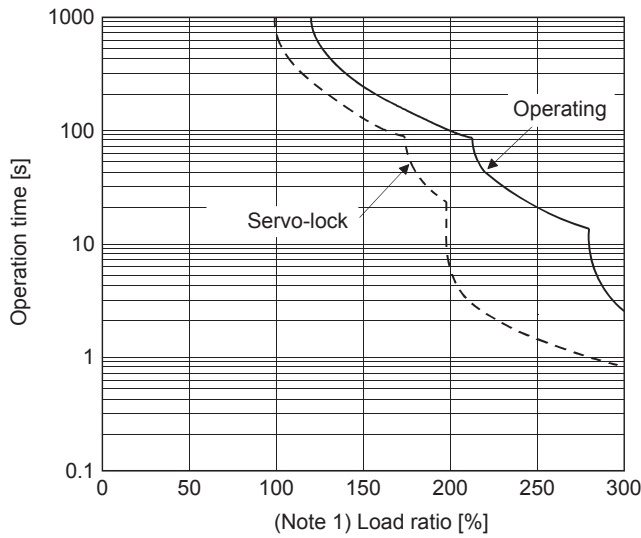

HG-SR121, HG-SR201, HG-SR152, HG-SR202,
HG-SR301, HG-SR352

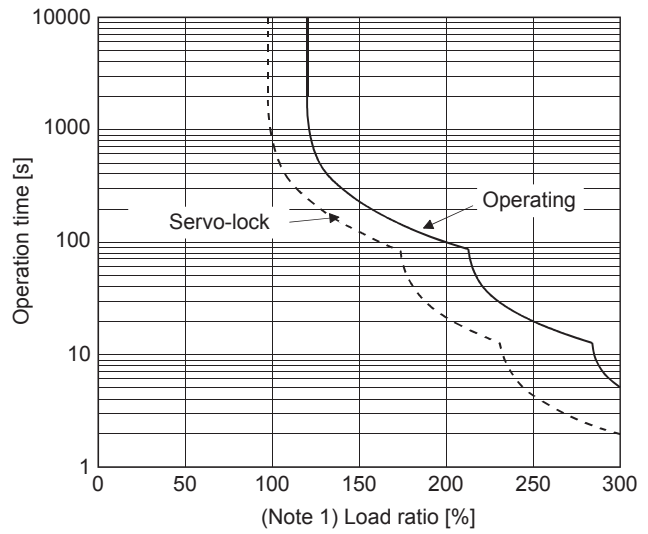

HG-SR421, HG-SR502, HG-SR702

- Note 1. If operation that generates torque more than 100% of the rating is performed with an abnormally high frequency in a servo motor stop status (servo-lock status) or in a 30 r/min or less low-speed operation status, the servo amplifier may malfunction
2. regardless of the electronic thermal protection.
- The load ratio ranging from 300 % to 350 % applies to the HG-KR servo motor.

Fig. 10.1 Electronic thermal protection characteristics

10. CHARACTERISTICS

10.2 Power supply capacity and generated loss

(1) Amount of heat generated by the servo amplifier

Table 10.1 indicates servo amplifiers' power supply capacities and losses generated under rated load. For thermal design of an enclosed type cabinet, use the values in the table in consideration for the worst operating conditions. The actual amount of generated heat will be intermediate between values at rated torque and servo-off according to the duty used during operation. When the servo motor is run at less than the rated speed, the power supply capacity will be smaller than the value in the table, but the servo amplifier's generated heat will not change.

Table 10.1 Power supply capacity and generated loss per servo motor at rated output

| Servo amplifier | Servo motor | (Note 1) Power supply capacity [kVA] | (Note 2) Servo amplifier- generated heat [W] | | Area required for heat dissipation [m ²] |
|-----------------|-------------|---|---|----------------|--|
| | | | At rated output | With servo-off | |
| MR-J4-10A | HG-MR053 | 03 | 25 | 15 | 05 |
| | HG-MR13 | 0.3 | 25 | 15 | 0.5 |
| | HG-KR053/13 | 0.3 | 25 | 15 | 0.5 |
| MR-J4-20A | HG-MR23 | 0.5 | 25 | 15 | 0.5 |
| | HG-KR23 | 0.5 | 25 | 15 | 0.5 |
| MR-J4-40A | HG-MR43 | 0.9 | 35 | 15 | 0.7 |
| | HG-KR43 | 0.9 | 35 | 15 | 0.7 |
| MR-J4-60A | HG-SR52 | 1.0 | 40 | 15 | 0.8 |
| | HG-SR51 | 1.0 | 40 | 15 | 0.8 |
| MR-J4-70A | HG-MR73 | 1.3 | 50 | 15 | 1.0 |
| | HG-KR73 | 1.3 | 50 | 15 | 1.0 |
| MR-J4-100A | HG-SR102 | 1.7 | 50 | 15 | 1.0 |
| | HG-SR81 | 1.5 | 50 | 15 | 1.0 |
| MR-J4-200A | HG-SR152 | 2.5 | 90 | 20 | 1.8 |
| | HG-SR202 | 3.5 | 90 | 20 | 1.8 |
| | HG-SR121 | 2.1 | 90 | 20 | 1.8 |
| | HG-SR201 | 3.5 | 90 | 20 | 1.8 |
| MR-J4-350A | HG-SR352 | 5.5 | 130 | 20 | 2.6 |
| | HG-SR301 | 4.8 | 120 | 20 | 2.4 |
| MR-J4-500A | HG-SR502 | 7.5 | 195 | 25 | 3.9 |
| | HG-SR421 | 6.3 | 160 | 25 | 3.2 |
| MR-J4-700A | HG-SR702 | 10 | 300 | 25 | 6.0 |

Note 1. Note that the power supply capacity will vary according to the power supply impedance. This value is applicable when the power factor improving AC reactor or power factor improving DC reactor are not used.

2. Heat generated during regeneration is not included in the servo amplifier-generated heat. To calculate heat generated by the regenerative option, refer to section 11.2.

10. CHARACTERISTICS

(2) Heat dissipation area for an enclosed type cabinet

The enclosed type cabinet (hereafter called the cabinet) which will contain the servo amplifier should be designed to ensure that its temperature rise is within +10 °C at the ambient temperature of 40 °C. (With an approximately 5 °C safety margin, the system should operate within a maximum 55 °C limit.) The necessary cabinet heat dissipation area can be calculated by equation 10.1.

$$A = \frac{P}{K \cdot \Delta T} \dots\dots\dots (10.1)$$

- A : Heat dissipation area [m²]
- P : Loss generated in the cabinet [W]
- ΔT : Difference between internal and ambient temperatures [°C]
- K : Heat dissipation coefficient [5 to 6]

When calculating the heat dissipation area with equation 10.1, assume that P is the sum of all losses generated in the cabinet. Refer to table 10.1 for heat generated by the servo amplifier. "A" indicates the effective area for heat dissipation, but if the cabinet is directly installed on an insulated wall, that extra amount must be added to the cabinet's surface area. The required heat dissipation area will vary with the conditions in the cabinet. If convection in the cabinet is poor and heat builds up, effective heat dissipation will not be possible. Therefore, arrangement of the equipment in the cabinet and the use of a cooling fan should be considered. Table 10.1 lists the cabinet dissipation area for each servo amplifier (guideline) when the servo amplifier is operated at the ambient temperature of 40 °C under rated load.

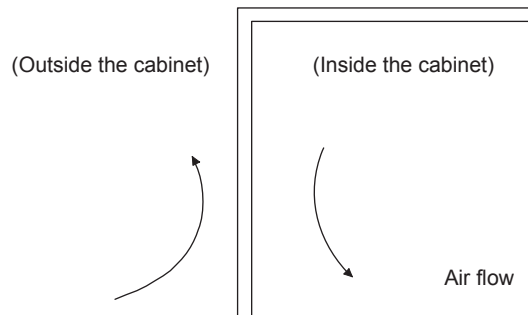

Fig. 10.2 Temperature distribution in an enclosed type cabinet

When air flows along the outer wall of the cabinet, effective heat exchange will be possible, because the temperature slope inside and outside the cabinet will be steeper.

10. CHARACTERISTICS

10.3 Dynamic brake characteristics

| POINT |
|---|
| <ul style="list-style-type: none"> ● Do not use dynamic brake to stop in a normal operation as it is the function to stop in emergency. ● For a machine operating at the recommended load to motor inertia ratio or less, the estimated number of usage times of the dynamic brake is 1000 times while the machine decelerates from the rated speed to a stop once in 10 minutes. ● Be sure to make EM1 (Forced stop) valid after servo motor stops when using EM1 (Forced stop) frequently in other than emergency. ● Servo motors for MR-J4 may have the different coasting distance from that of the previous model. |

10.3.1 Dynamic brake operation

(1) Calculation of coasting distance

Fig. 10.3 shows the pattern in which the servo motor comes to a stop when the dynamic brake is operated. Use equation 10.2 to calculate an approximate coasting distance to a stop. The dynamic brake time constant τ varies with the servo motor and machine operation speeds. (Refer to (2)(a), (b) of this section.)

A working part generally has a friction force. Therefore, actual coasting distance will be shorter than a maximum coasting distance calculated with the following equation.

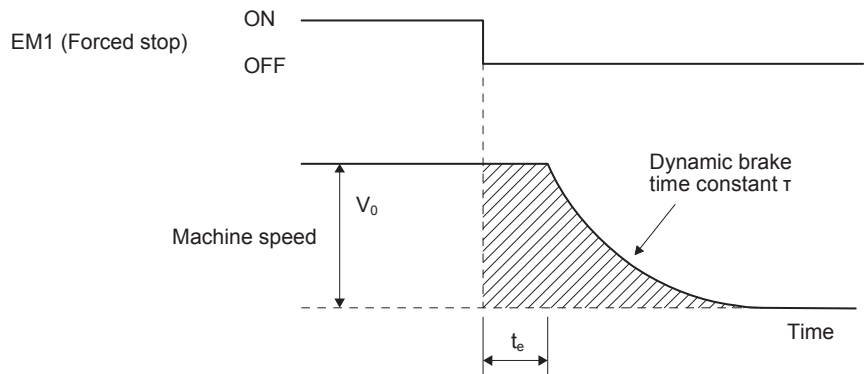

Fig. 10.3 Dynamic brake operation diagram

$$L_{\max} = \frac{V_0}{60} \cdot \left\{ t_e + \tau \left(1 + \frac{J_L}{J_M} \right) \right\} \dots\dots\dots (10.2)$$

- L_{\max} : Maximum coasting distance [mm]
- V_0 : Machine's fast feed speed [mm/min]
- J_M : Moment of inertia of the servo motor [kg·cm²]
- J_L : Load moment of inertia converted into equivalent value on servo motor shaft [kg·cm²]
- τ : Dynamic brake time constant [s]
- t_e : Delay time of control section [s]

For 7 kW or lower servo, there is internal relay delay time of about 10 ms.

10. CHARACTERISTICS

(2) Dynamic brake time constant

The following shows necessary dynamic brake time constant τ for equation 10.2.

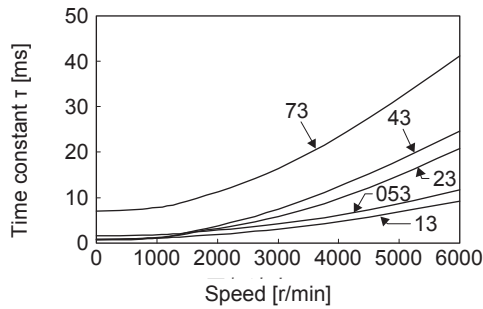

HG-MR series

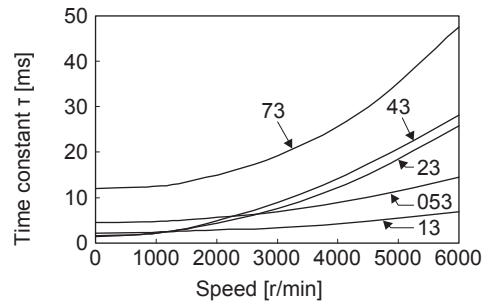

HG-KR series

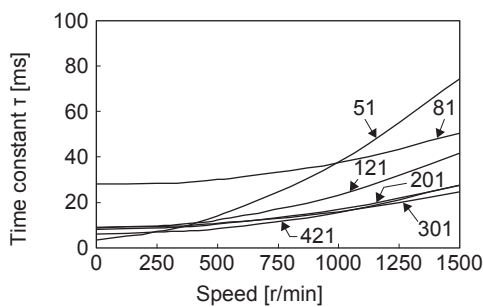

HG-SR1000 r/min series

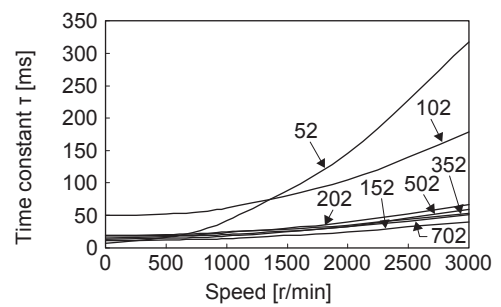

HG-SR2000 r/min series

10.3.2 Permissible load to motor inertia when the dynamic brake is used

Use the dynamic brake under the load to motor inertia ratio indicated in the following table. If the load inertia moment is higher than this value, the dynamic brake may burn. If the load to motor inertia ratio exceeds the indicated value, contact your local sales office.

The values of the permissible load to motor inertia ratio in the table are the values at the maximum rotation speed of the servo motor.

| Servo amplifier | Servo motor | | | |
|-----------------|-------------|-----------------------------|----------|-----------|
| | HG-KR_ | HG-MR_ | HG-SR_1 | HG-SR_2 |
| MR-J4-10B | 30 | HG-MR053: 35 HG-MR13: 32 | / | / |
| MR-J4-20B | 30 | 32 | | |
| MR-J4-40B | 30 | 32 | | |
| MR-J4-60B | / | | 30 | 30 |
| MR-J4-70B | 30 | 32 | / | |
| MR-J4-100B | / | | 30 | 30 |
| MR-J4-200B | | | 30 | 21 |
| MR-J4-350B | | | 16 | 13 (Note) |
| MR-J4-500B | | | 15 | 13 (Note) |
| MR-J4-700B | | | 5 (Note) | |

Note. The permissible load to motor inertia ratio is 15 at the rated rotation speed.

10. CHARACTERISTICS

10.4 Cable bending life

The bending life of the cables is shown below. This graph calculated values. Since they are not guaranteed values, provide a little allowance for these values.

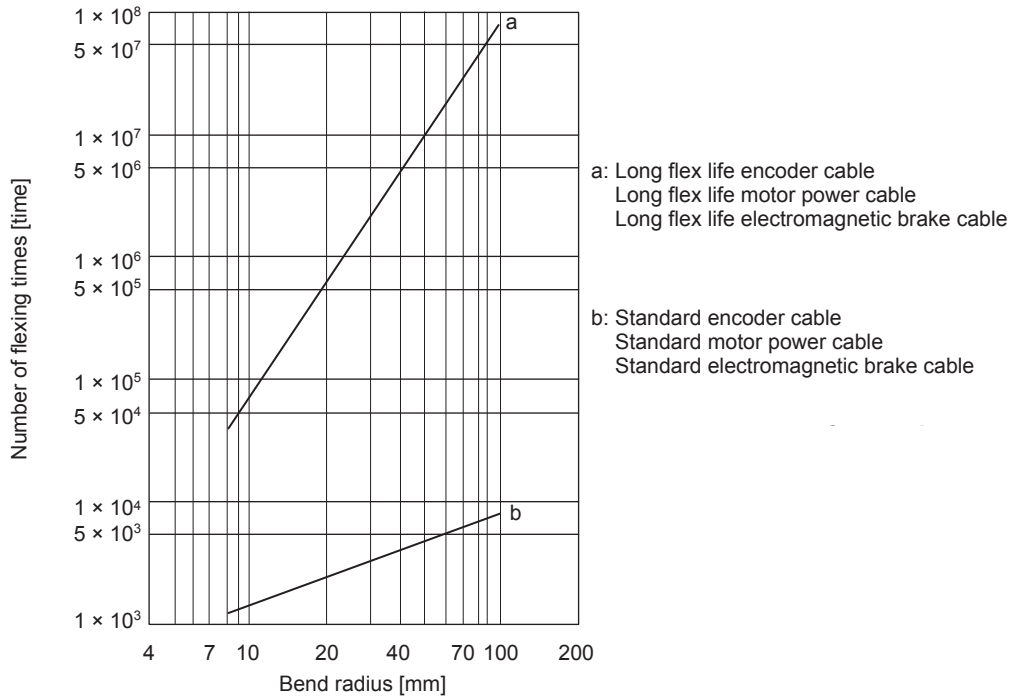

10.5 Inrush currents at power-on of main circuit and control circuit

The following table indicates the inrush currents (reference data) that will flow when 240 V AC is applied at the power supply capacity of 2500 kVA and the wiring length of 1 m.

| Servo amplifier | Inrush currents (A_{0-P}) | |
|--|---|---|
| | Main circuit power supply (L1, L2, and L3) | Control circuit power supply (L11 and L21) |
| MR-J4-10A, MR-J4-20A, MR-J4-40A, MR-J4-60A | 30 A (attenuated to approx. 3 A in 20 ms) | 20 A to 30 A (attenuated to approx. 1 A in 20 ms) |
| MR-J4-70A, MR-J4-100A | 34 A (attenuated to approx. 7 A in 20 ms) | |
| MR-J4-200A, MR-J4-350A | 113 A (attenuated to approx. 12 A in 20 ms) | |
| MR-J4-500A | 42 A (attenuated to approx. 20 A in 20 ms) | 34 A (attenuated to approx. 2 A in 20 ms) |
| MR-J4-700A | 85 A (attenuated to approx. 20 A in 30 ms) | |

Since large inrush currents flow in the power supplies, always use molded case circuit breakers and magnetic contactors. (Refer to section 11.10.)

When circuit protectors are used, it is recommended that the inertia delay type, which is not tripped by an inrush current, be used.

11. OPTIONS AND AUXILIARY EQUIPMENT

11. OPTIONS AND AUXILIARY EQUIPMENT

| | |
|--|---|
|  WARNING | <ul style="list-style-type: none">● Before connecting any option or peripheral equipment, turn off the power and wait for 15 minutes or more until the charge lamp turns off. Then, confirm that the voltage between P+ and N- is safe with a voltage tester and others. Otherwise, an electric shock may occur. In addition, when confirming whether the charge lamp is off or not, always confirm it from the front of the servo amplifier. |
|--|---|

| | |
|---|---|
|  Cautions | <ul style="list-style-type: none">● Use the specified auxiliary equipment and options to prevent a malfunction or a fire. |
|---|---|

11.1 Cable/connector sets

| POINT |
|---|
| <ul style="list-style-type: none">● The IP rating indicated is the cable's or connector's protection against ingress of dust and water when the cable or connector is connected to a servo amplifier or servo motor. If the IP rating of the cable, connector, servo amplifier and servo motor vary, the overall IP rating depends on the lowest IP rating of all components. |

Purchase the cable and connector options indicated in this section.





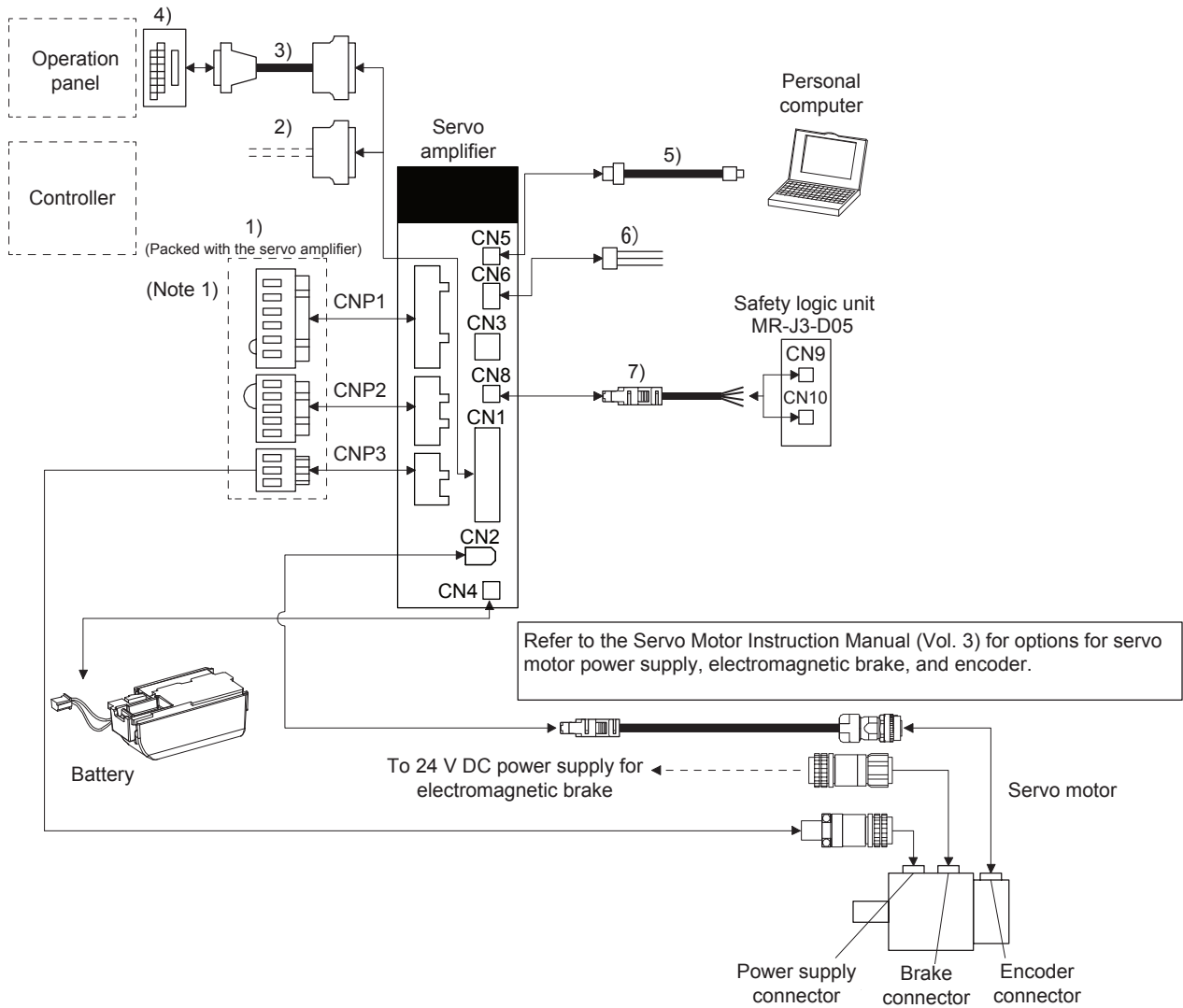



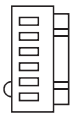

11. OPTIONS AND AUXILIARY EQUIPMENT

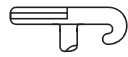
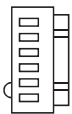
11.1.1 Combinations of cable/connector sets

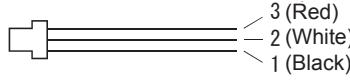

- Note 1. Connectors for 3.5 kW or less. For 5 kW or more, it is a terminal block.
 Note 2. When not using the STO function, attach a short-circuit connector (8) supplied with a servo amplifier.

11. OPTIONS AND AUXILIARY EQUIPMENT

| No. | Name | Model | Description | Application | | |
|-----|-------------------------------------|---|---|--|--|--|
| 1) | Servo amplifier power connector set | |  <p>CNP1 Connector: 06JFAT-SAXGDK-H7.5 (JST) Applicable wire size: 0.8 mm² to 2.1 mm² (AWG 18 to 14) Insulator OD: to 3.9 mm</p> |  <p>CNP2 Connector: 05JFAT-SAXGDK-H5.0 (JST)</p> |  <p>CNP3 Connector: 03JFAT-SAXGDK-H7.5 (JST)</p>  <p>Open tool J-FAT-OT (JST)</p> | Supplied with servo amplifiers of 1 kW or less. |
| | | |  <p>CNP1 Connector: 06JFAT-SAXGFK-XL (JST) CNP3 Applicable wire size: 1.25 mm² to 5.5 mm² (AWG 16 to 10) Insulator OD: to 4.7 mm</p> |  <p>CNP2 Connector: 05JFAT-SAXGDK-H5.0 (JST) CNP2 Applicable wire size: 0.8 mm² to 2.1 mm² (AWG 18 to 14) Insulator OD: to 3.9 mm</p> |  <p>CNP3 Connector: 03JFAT-SAXGFK-XL (JST)</p>  <p>Open tool J-FAT-OT-EXL (JST)</p> | Supplied with servo amplifiers of 2 kW and 3.5 kW. |
| 2) | Junction terminal block cable | MR-J2M-CN1TBL_M Cable length: 0.5 m, 1 m (Refer to section 11.6.) | <p>Junction terminal block connector CN1 connector Connector: D7950-B500FL (3M) Connector: 10150-6000EL Shell kit: 10350-3210-000 (3M or equivalent)</p>  | For junction terminal block connection | | |
| 3) | CN1 connector set | MR-J3CN1 | <p>Connector: 10150-3000PE Shell kit: 10350-52F0-008 (3M or equivalent)</p>  | | | |
| 4) | Junction terminal block | MR-TB50 | Refer to section 11.6. | | | |
| 5) | USB cable | MR-J3USBCBL3M Cable length: 3 m | <p>CN5 connector mini-B connector (5 pins) Personal computer connector A connector</p>  | For connection with PC-AT compatible personal computer | | |
| 6) | Monitor cable | MR-J3CN6CBL1M Cable length: 1 m | <p>CN6 connector Housing: 51004-0300 Terminal: 50011-8100 (Molex)</p>  | | | |
| 7) | STO cable | MR-D05UDL3M-B | <p>Connector set: 2069250-1 (TE Connectivity)</p>  | Connection cable for the CN8 connector | | |
| 8) | Short-circuit connector | |  | Supplied with servo amplifier | | |

11. OPTIONS AND AUXILIARY EQUIPMENT

11.1.2 MR-D05UDL3M-B STO cable

This cable is for connecting an external device to the CN8 connector.

| Cable model | Cable length | Application |
|---------------|--------------|--|
| MR-D05UDL3M-B | 3 m | Connection cable for the CN8 connector |

(1) Configuration diagram

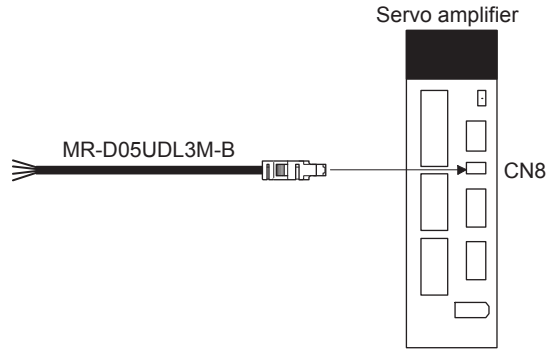

(2) Internal wiring diagram

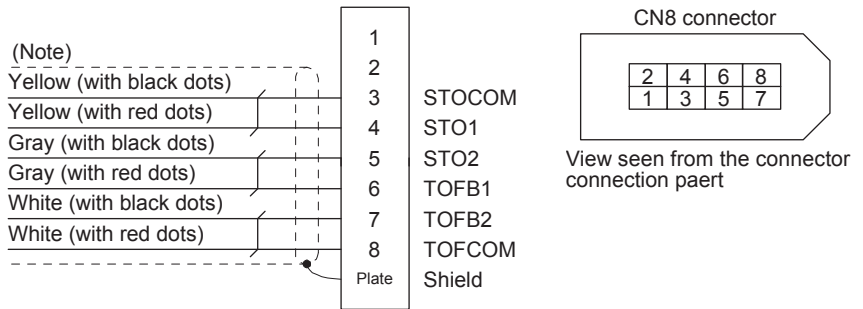

Note. Do not use the two core wires with orange sheath (with red or black dots).

11. OPTIONS AND AUXILIARY EQUIPMENT

11.2 Regenerative options



Cautions

● Do not use servo amplifiers with regenerative options other than the combinations specified below.
Otherwise, it may cause a fire.

11.2.1 Combination and regenerative power

The power values in the table are resistor-generated powers and not rated powers.

| Servo amplifier | Regenerative Power [W] | | | | | | | | | |
|-----------------|--------------------------------|-----------------|----------------|----------------|---------------|-----------------|----------------|-----------------------|----------------------|------------------------|
| | Built-in regenerative resistor | MR-RB032 [40 Ω] | MR-RB12 [40 Ω] | MR-RB30 [13 Ω] | MR-RB3N [9 Ω] | MR-RB31 [6.7 Ω] | MR-RB32 [40 Ω] | (Note) MR-RB50 [13 Ω] | (Note) MR-RB5N [9 Ω] | (Note) MR-RB51 [6.7 Ω] |
| MR-J4-10A | | 30 | | | | | | | | |
| MR-J4-20A | 10 | 30 | 100 | | | | | | | |
| MR-J4-40A | 10 | 30 | 100 | | | | | | | |
| MR-J4-60A | 10 | 30 | 100 | | | | | | | |
| MR-J4-70A | 20 | 30 | 100 | | | | 300 | | | |
| MR-J4-100A | 20 | 30 | 100 | | | | 300 | | | |
| MR-J4-200A | 100 | | | 300 | | | | 500 | | |
| MR-J4-350A | 100 | | | | 300 | | | | 500 | |
| MR-J4-500A | 130 | | | | | 300 | | | | 500 |
| MR-J4-700A | 170 | | | | | 300 | | | | 500 |

Note. Always install a cooling fan.

11. OPTIONS AND AUXILIARY EQUIPMENT

11.2.2 Selection of regenerative option

(1) Rotary servo motor:

Use the following method when regeneration occurs continuously in vertical motion applications or when it is desired to make an in-depth selection of the regenerative option.

(a) Regenerative energy calculation

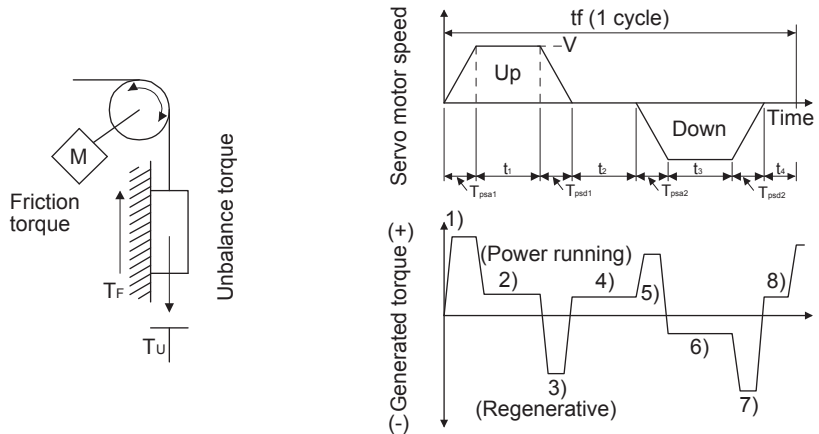

Formulas for calculating torque and energy in operation

| Regenerative power | Torque applied to servo motor [N•m] | Energy E [J] |
|--------------------|---|---|
| 1) | $T_1 = \frac{(J_L + J_M) \cdot V}{9.55 \cdot 10^4} \cdot \frac{1}{t_{psa1}} + T_U + T_F$ | $E_1 = \frac{0.1047}{2} \cdot V \cdot T_1 \cdot t_{psa1}$ |
| 2) | $T_2 = T_U + T_F$ | $E_2 = 0.1047 \cdot V \cdot T_2 \cdot t_1$ |
| 3) | $T_3 = \frac{-(J_L + J_M) \cdot V}{9.55 \cdot 10^4} \cdot \frac{1}{t_{psa2}} + T_U + T_F$ | $E_3 = \frac{0.1047}{2} \cdot V \cdot T_3 \cdot t_{psa2}$ |
| 4), 8) | $T_4, T_8 = T_U$ | $E_4, E_8 = 0$ (No regeneration) |
| 5) | $T_5 = \frac{(J_L + J_M) \cdot V}{9.55 \cdot 10^4} \cdot \frac{1}{t_{psd2}} - T_U + T_F$ | $E_5 = \frac{0.1047}{2} \cdot V \cdot T_5 \cdot t_{psd2}$ |
| 6) | $T_6 = -T_U + T_F$ | $E_6 = 0.1047 \cdot V \cdot T_6 \cdot t_3$ |
| 7) | $T_7 = \frac{-(J_L + J_M) \cdot V}{9.55 \cdot 10^4} \cdot \frac{1}{t_{psd2}} - T_U + T_F$ | $E_7 = \frac{0.1047}{2} \cdot V \cdot T_7 \cdot t_{psd2}$ |

From the calculation results in 1) to 8), find the absolute value (E_s) of the sum total of negative energies.

11. OPTIONS AND AUXILIARY EQUIPMENT

(b) Losses of servo motor and servo amplifier in regenerative mode

The following table lists the efficiencies and other data of the servo motor and servo amplifier in the regenerative mode.

| Servo amplifier | Inverse efficiency [%] | C charge [J] | Servo amplifier | Inverse efficiency [%] | C charge [J] |
|-----------------|------------------------|--------------|-----------------|------------------------|--------------|
| MR-J4-10A | 55 | 9 | MR-J4-100A | 85 | 18 |
| MR-J4-20A | 75 | 9 | MR-J4-200A | 85 | 36 |
| MR-J4-40A | 85 | 11 | MR-J4-350A | 85 | 40 |
| MR-J4-60A | 85 | 11 | MR-J4-500A | 90 | 45 |
| MR-J4-70A | 85 | 18 | MR-J4-700A | 90 | 70 |

Inverse efficiency (η): Efficiency including some efficiencies of the servo motor and servo amplifier when rated (regenerative) torque is generated at rated speed. Since the efficiency varies with the speed and generated torque, allow for about 10%.

Capacitor charging (E_c): Energy charged into the electrolytic capacitor in the servo amplifier

Subtract the capacitor charging from the result of multiplying the sum total of regenerative energies by the inverse efficiency to calculate the energy consumed by the regenerative option.

$$ER[J] = \eta \cdot E_s - E_c$$

Calculate the power consumption of the regenerative option on the basis of single-cycle operation period t_f [s] to select the necessary regenerative option.

$$PR[W] = ER/t_f$$

11. OPTIONS AND AUXILIARY EQUIPMENT

11.2.3 Parameter setting

Set [Pr. PA02] according to the option to be used.

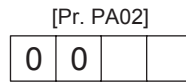

- Selection of regenerative option
- 00: Regenerative option is not used.
 - For servo amplifier of 100 W, regenerative resistor is not used.
 - For servo amplifier of 0.2 kW to 7 kW, built-in regenerative resistor is used.
 - 01: FR-BU2/FR-RC/FR-CV
 - 02: MR-RB032
 - 03: MR-RB12
 - 04: MR-RB32
 - 05: MR-RB30
 - 06: MR-RB50 (Cooling fan is required)
 - 08: MR-RB31
 - 09: MR-RB51 (Cooling fan is required)
 - 0B: MR-RB3N
 - 0C: MR-RB5N (Cooling fan is required)

11.2.4 Connection of regenerative option

| POINT |
|---|
| ●When the MR-RB50, MR-RB51, or MR-RB5N is used, a cooling fan is required to cool it. The cooling fan should be prepared by the customer. |
| ●For the sizes of wires used for wiring, refer to section 11.9. |

The regenerative option generates heat of 100 °C higher than the ambient temperature. Fully consider heat dissipation, installation position, used wires, etc. to place the option. For wiring, use flame-resistant wires or make the wires flame-resistant and keep them away from the regenerative option. Always use twisted cables of max. 5 m length for connection with the servo amplifier.

11. OPTIONS AND AUXILIARY EQUIPMENT

(1) MR-J4-500A or less

Always remove the wiring from across P+ - D and fit the regenerative option across P+ - C. G3 and G4 are thermal sensor's terminals. Between G3 and G4 is opened when the regenerative option overheats abnormally.

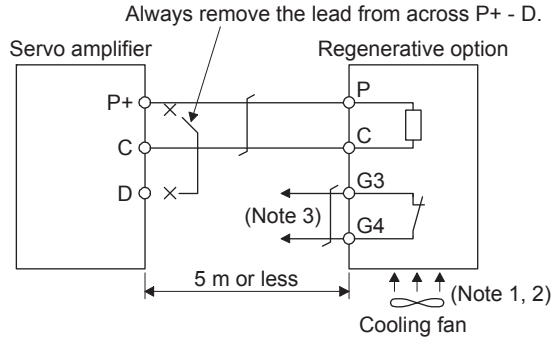

- Note 1. When using the MR-RB50, or MR-RB5N, forcibly cool it with a cooling fan (92 mm × 92 mm, minimum air flow: 1.0 m³).
- Note 2. When the ambient temperature is more than 55 °C and the regenerative load ratio is more than 60% in MR-RB30, MR-RB-31, MR-RB32 and MR-RB3N, forcibly cool the air with a cooling fan (1.0 m³/min or more, 92 mm × 92 mm). A cooling fan is not required if the ambient temperature is 35 °C or less. (A cooling fan is required for the shaded area in the following graph.)

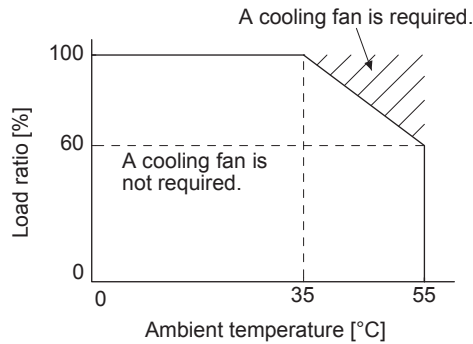

3. Make up a sequence which will switch off the magnetic contactor when abnormal heating occurs.

G3-G4 contact specifications

- Maximum voltage: 120 V AC/DC
- Maximum current: 0.5 A/4.8 V DC
- Maximum capacity: 2.4 VA

11. OPTIONS AND AUXILIARY EQUIPMENT

(2) MR-J4-700A

Always remove the wiring (across P+ - C) of the servo amplifier built-in regenerative resistor and fit the regenerative option across P+ - C. G3 and G4 are thermal sensor's terminals. Between G3 and G4 is opened when the regenerative option overheats abnormally.

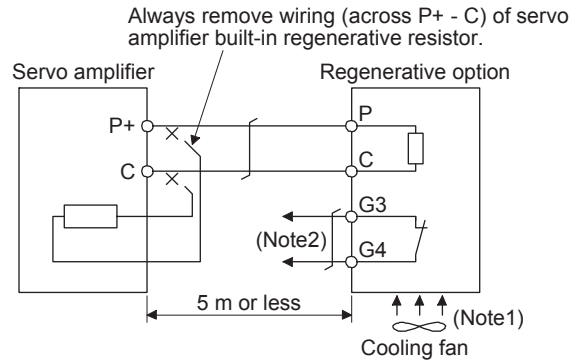

- Note 1. When using the MR-RB51, forcibly cool it with a cooling fan (92 mm × 92 mm, minimum air flow: 1.0 m³).
- Note 2. Make up a sequence which will switch off the magnetic contactor when abnormal heating occurs.

G3-G4 contact specifications

- Maximum voltage: 120 V AC/DC
- Maximum current: 0.5 A/4.8 V DC
- Maximum capacity: 2.4 VA

When using the regenerative option, remove the servo amplifier's built-in regenerative resistor wires (across P+ - C), fit them back to back, and secure them to the frame with the accessory screw as shown below.

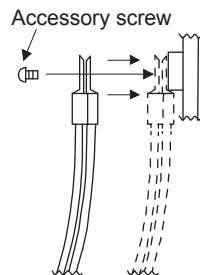

11. OPTIONS AND AUXILIARY EQUIPMENT

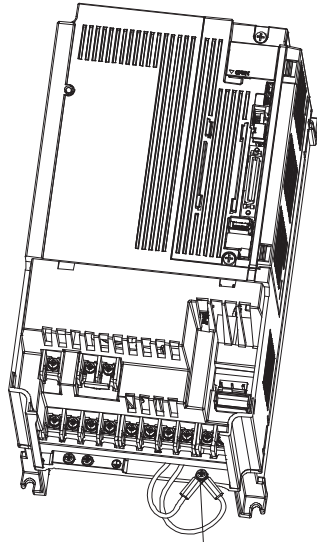

built-in regenerative resistor lead
terminal fixing screw

11. OPTIONS AND AUXILIARY EQUIPMENT

11.2.5 Dimensions

(1) MR-RB12

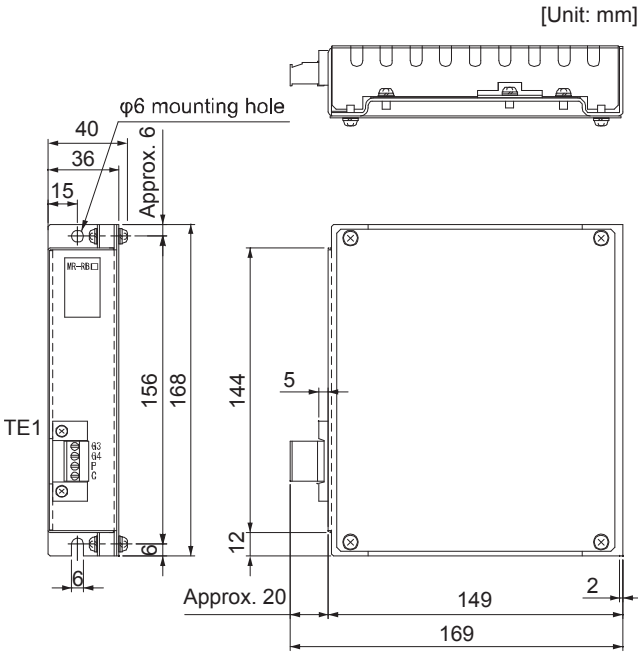

TE1 terminal block

| |
|----|
| G3 |
| G4 |
| P |
| C |

Applicable wire size: 0.2 mm² to 2.5 mm² (AWG14 to 12)

Tightening torque: 0.5 to 0.6 [N•m]

Mounting screw

Screw size: M5

Tightening torque: 3.24 [N•m]

Mass: 1.1 [kg]

(2) MR-RB30/MR-RB31/MR-RB32/MR-RB3N

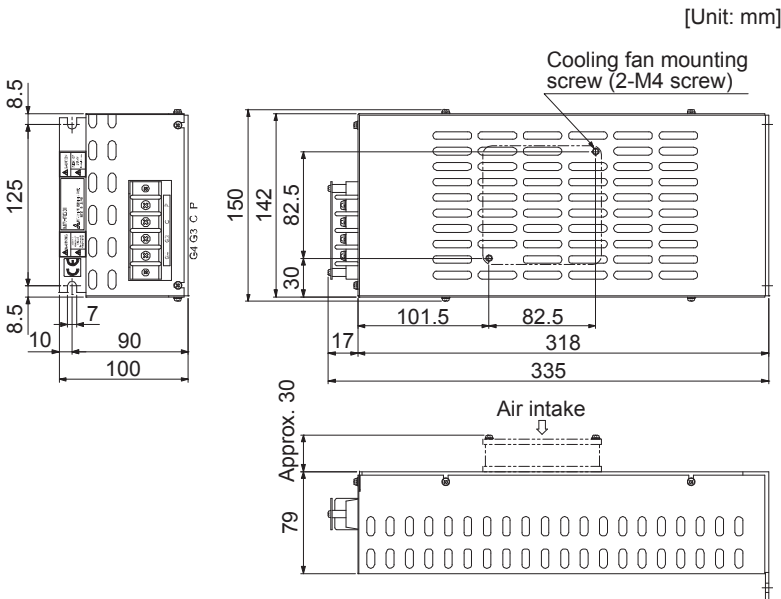

Terminal block

| |
|----|
| P |
| C |
| G3 |
| G4 |

Terminal screw size: M4

Tightening torque: 1.2 [N•m]

Mounting screw

Screw size: M5

Tightening torque: 5.4 [N•m]

Mass: 2.9 [kg]

11. OPTIONS AND AUXILIARY EQUIPMENT

(3) MR-RB50/MR-RB51/MR-RB5N

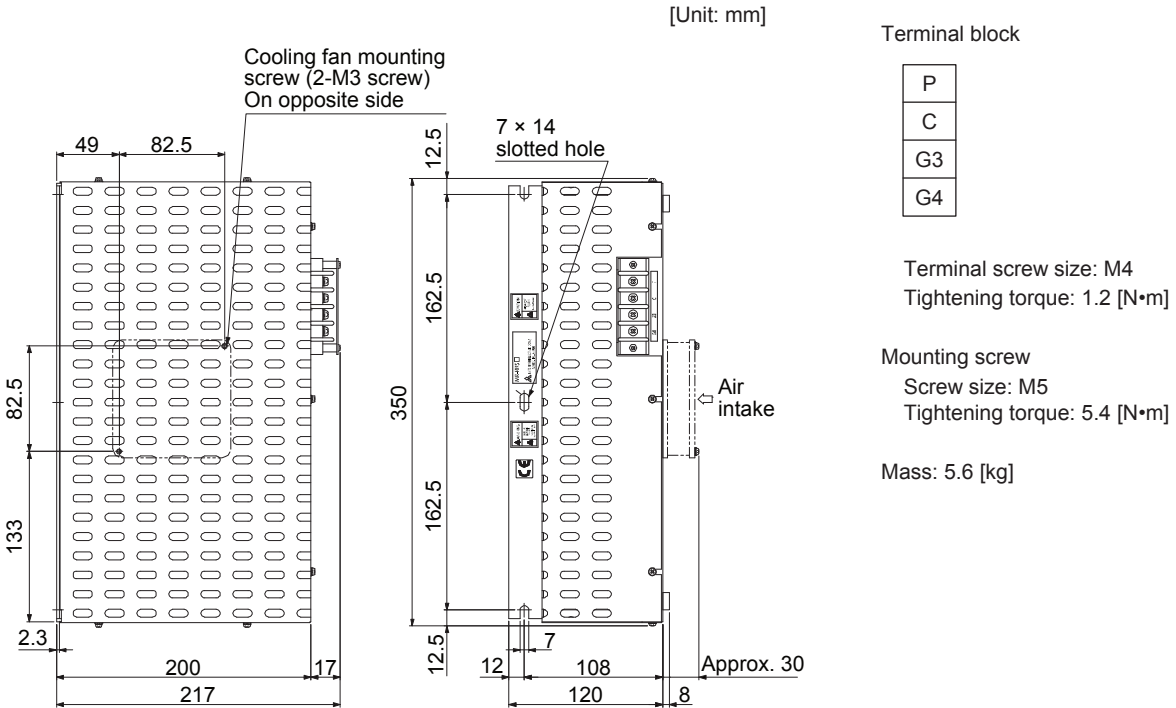

(4) MR-RB032

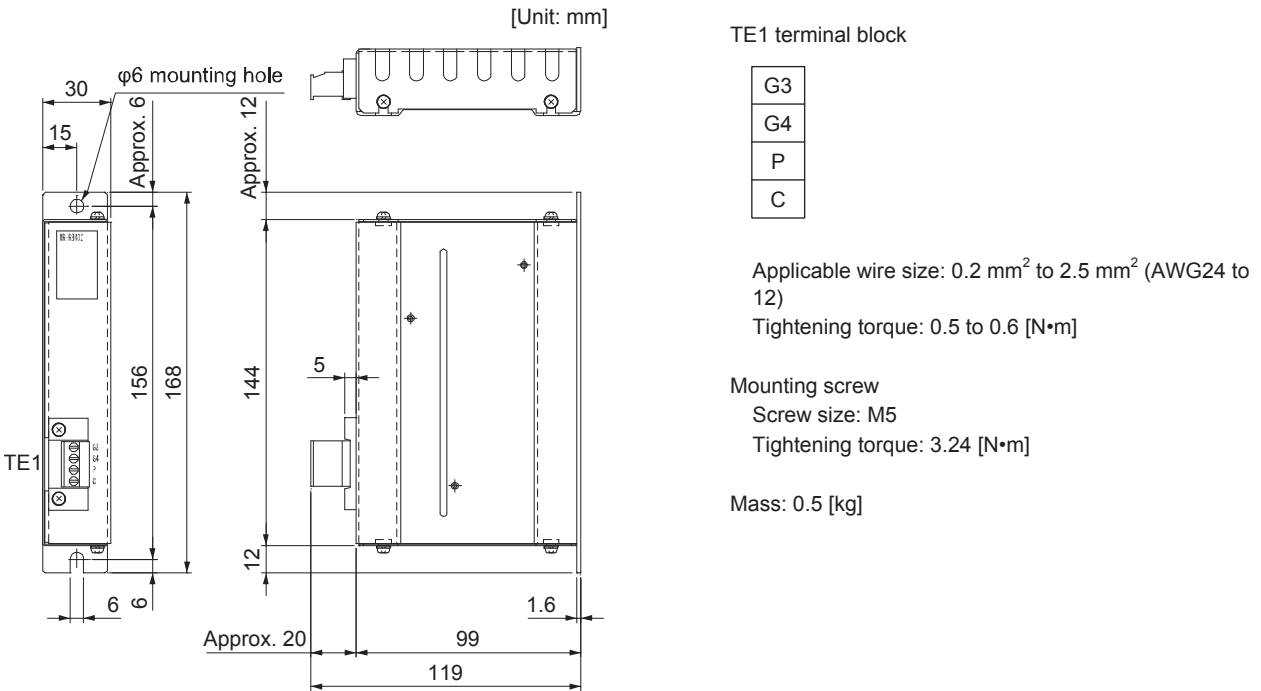

11. OPTIONS AND AUXILIARY EQUIPMENT

11.3 FR-BU2 Brake unit

| POINT |
|---|
| <ul style="list-style-type: none"> ● When a brake unit and a resistor unit are installed horizontally or diagonally, the heat dissipation effect diminishes. Install them on a flat surface vertically. ● Temperature of the resistor unit case rises to higher than +100 °C. Keep cables and flammable materials away from the case. ● Ambient temperature condition of the brake unit is between -10 °C to 50 °C. Note that the condition is different from the ambient temperature condition of the servo amplifier (between 0 °C and 55 °C). ● Configure the circuit to shut down the power-supply with the alarm output of the brake unit and the resistor unit under abnormal condition. ● Use the brake unit with a combination indicated in section 11.3.1. ● For executing a continuous regenerative operation, use FR-RC power regenerative converter or FR-CV power regenerative common converter. ● Brake unit and regenerative options (Regenerative resistor) cannot be used simultaneously. |

Connect the brake unit to the bus of the servo amplifier. As compared to the MR-RB regenerative option, the brake unit can return larger power. Use the brake unit when the regenerative option cannot provide sufficient regenerative capability.

When using the brake unit, set [Pr. PA02] of the servo amplifier to "_ _ 0 1".

When using the brake unit, always refer to the FR-BU2-(H) Brake Unit Instruction Manual.

11.3.1 Selection

Use a combination of servo amplifier, brake unit and resistor unit listed below.

| Brake unit | | Resistor unit | Number of connected units | Permissible continuous power [kW] | Resultant resistance [Ω] | Applicable servo amplifier |
|-------------|------------|---------------|---------------------------|-----------------------------------|--------------------------|----------------------------|
| 200 V class | FR-BU2-15K | FR-BR-15K | 2 (parallel) | 1.98 | 4 | MR-J4-500A MR-J4-700A |
| | FR-BU2-30K | FR-BR-30K | 1 | 1.99 | 4 | MR-J4-500A MR-J4-700A |

11.3.2 Brake unit parameter setting

Whether a parameter can be changed or not is listed below.

| Parameter | | Change possible/impossible | Remarks |
|-----------|--|----------------------------|--|
| No. | Name | | |
| 0 | Brake mode switchover | Impossible | Do not change the parameter |
| 1 | Monitor display data selection | Possible | Refer to the FR-BU2-(H) Brake Unit Instruction Manual. |
| 2 | Input terminal function selection 1 | Impossible | Do not change the parameter |
| 3 | Input terminal function selection 2 | | |
| 77 | Parameter write selection | | |
| 78 | Cumulative energization time carrying-over times | | |
| CLr | Parameter clear | | |
| ECL | Alarm history clear | | |
| C1 | For manufacturer setting | | |

11. OPTIONS AND AUXILIARY EQUIPMENT

11.3.3 Connection example

| POINT |
|---|
| <ul style="list-style-type: none"> ● EM2 has the same signal as EM1 in the torque control mode. ● Connecting PR terminal of the brake unit to P+ terminal of the servo amplifier results in brake unit malfunction. Always connect the PR terminal of the brake unit to the PR terminal of the resistor unit. |

- (1) Combination with FR-BR resistor unit
 (a) When connecting a brake unit to a servo amplifier

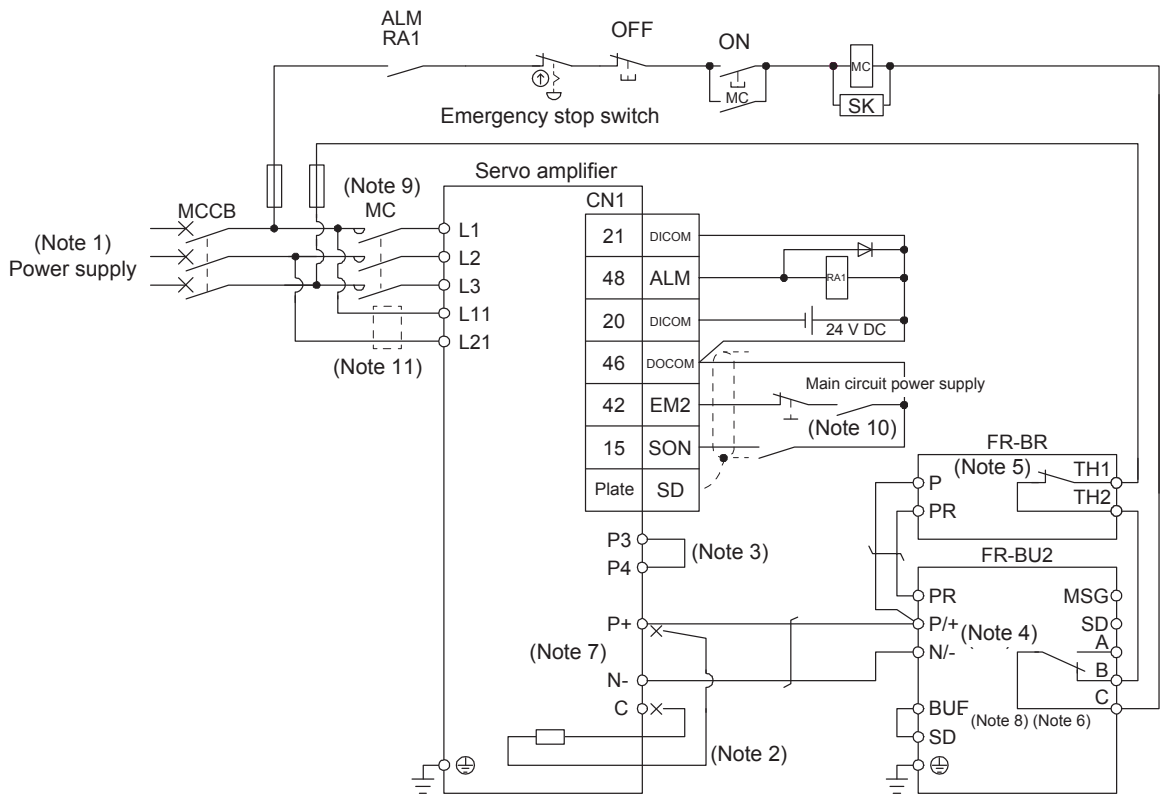

- Note 1. For power supply specifications, refer to section 1.3.
- Note 2. For the servo amplifier of 7 kW, always disconnect the lead wire of built-in regenerative resistor, which is connected to the P+ and C terminals.
- Note 3. Always connect between P3 and P4 terminals. (factory-wired) Use either the power factor improving DC reactor or the power factor improving AC reactor. When using the power factor improving DC reactor, refer to section 11.11.
- Note 4. Connect P/+ and N/- terminals of the brake unit to a correct destination. Incorrect connection destination results in servo amplifier and brake unit malfunction.
- Note 5. Contact rating: 1b contact, 110 V AC_5 A/220 V AC_3 A
 Normal condition: TH1-TH2 is conducting. Abnormal condition: TH1-TH2 is not conducting.
- Note 6. Contact rating: 230 V AC_0.3 A/30 V DC_0.3 A
 Normal condition: B-C is conducting/A-C is not conducting. Abnormal condition: B-C is not conducting/A-C is conducting.
- Note 7. Do not connect more than one cable to each P+ to N- terminals of the servo amplifier.
- Note 8. Always connect BUE and SD terminals. (factory-wired)
- Note 9. Depending on the main circuit voltage and operation pattern, bus voltage decreases, and that may cause the forced stop deceleration to shift to the dynamic brake deceleration. When dynamic brake deceleration is not required, slow the time to turn off the magnetic contactor.
- Note 10. Configure up a circuit to turn off EM2 when the main circuit power is turned off to prevent an unexpected restart of the servo amplifier.
- Note 11. When wires used for L11 and L21 are thinner than wires used for L1, L2, and L3, use a molded case circuit breaker.

11. OPTIONS AND AUXILIARY EQUIPMENT

(b) When connecting two brake units to a servo amplifier

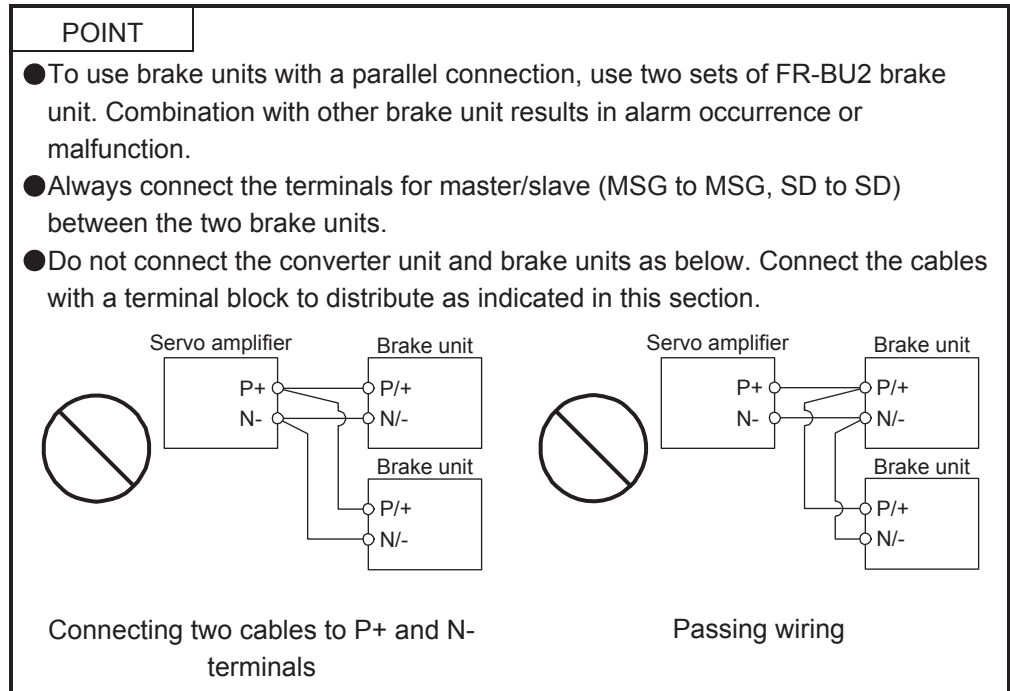

11. OPTIONS AND AUXILIARY EQUIPMENT

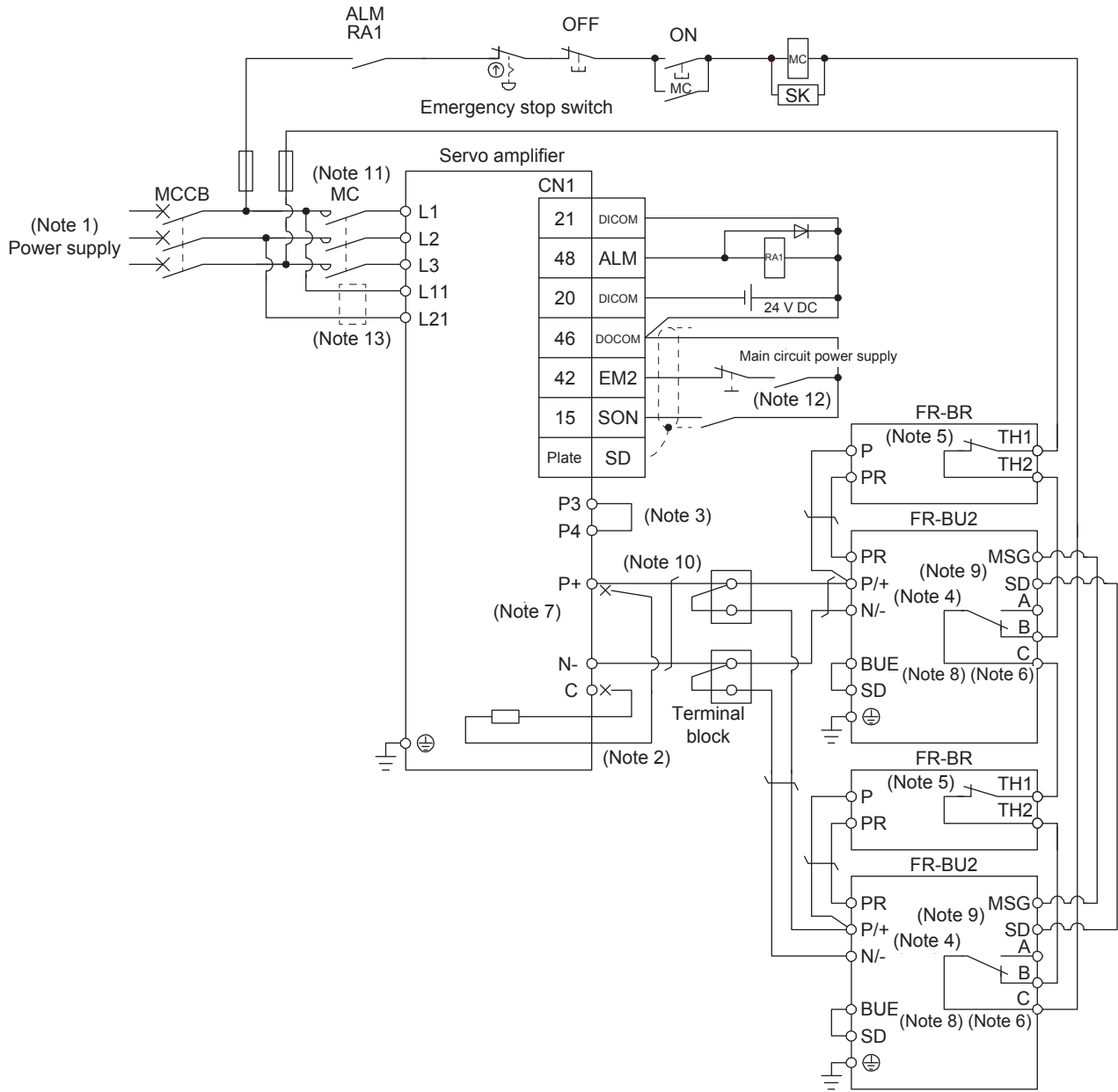

11. OPTIONS AND AUXILIARY EQUIPMENT

- Note
- For power supply specifications, refer to section 1.3.
 - For the servo amplifier of 7 kW, always disconnect the lead wire of built-in regenerative resistor, which is connected to the P+ and C terminals.
 - Always connect between P3 and P4 terminals. (factory-wired) Use either the power factor improving DC reactor or the power factor improving AC reactor. When using the power factor improving DC reactor, refer to section 11.11.
 - Connect P/+ and N/- terminals of the brake unit to a correct destination. Incorrect connection destination results in servo amplifier and brake unit malfunction.
 - Contact rating: 1b contact, 110 V AC_5 A/220 V AC_3 A
Normal condition: TH1-TH2 is conducting. Abnormal condition: TH1-TH2 is not conducting.
 - Contact rating: 230 V AC_0.3 A/30 V DC_0.3 A
Normal condition: B-C is conducting/A-C is not conducting. Abnormal condition: B-C is not conducting/A-C is conducting.
 - Do not connect more than one cable to each P+ to N- terminals of the servo amplifier.
 - Always connect BUE and SD terminals. (factory-wired)
 - Connect MSG and SD terminals of the brake unit to a correct destination. Incorrect connection destination results in servo amplifier and brake unit malfunction.
 - For the cable to connect the terminal block and the P+ and N- terminals of the servo amplifier, use the cable indicated in (3)(b) of this section.
 - Depending on the main circuit voltage and operation pattern, bus voltage decreases, and that may cause the forced stop deceleration to shift to the dynamic brake deceleration. When dynamic brake deceleration is not required, slow the time to turn off the magnetic contactor.
 - Configure up a circuit to turn off EM2 when the main circuit power is turned off to prevent an unexpected restart of the servo amplifier.
 - When wires used for L11 and L21 are thinner than wires used for L1, L2, and L3, use a molded case circuit breaker.

(2) Connection instructions

The cables between the servo amplifier and the brake unit, and between the resistor unit and the brake unit should be as short as possible. Always twist the cable longer than 5 m (twist five times or more per one meter). Even when the cable is twisted, the cable should be less than 10 m. Using cables longer than 5 m without twisting or twisted cables longer than 10 m, may result in the brake unit malfunction.

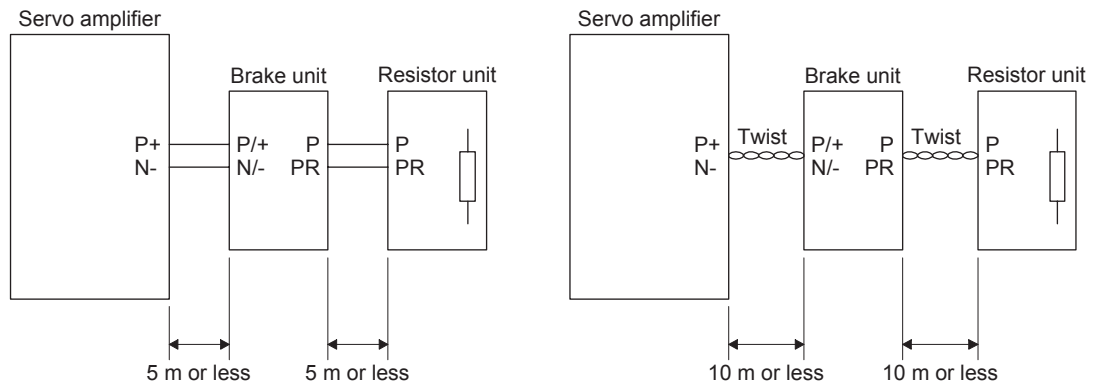

(3) Cables

(a) Cables for the brake unit

For the brake unit, HIV cable (600 V grade heat-resistant PVC insulated wire) is recommended.

1) Main circuit terminal

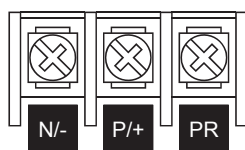

Terminal block

| 200 V class | Brake unit | Main circuit terminal screw size | Crimp terminal N/-, P/+, PR, ⊕ | Tightening torque [N·m] | Wire size | |
|-------------|------------|----------------------------------|-----------------------------------|-------------------------|-----------------------------|-----|
| | | | | | N/-, P/+, PR, ⊕ | |
| | | | | | HIV wire [mm ²] | AWG |
| | FR-BU2-15K | M4 | 5.5-4 | 1.5 | 3.5 | 12 |
| | FR-BU2-30K | M5 | 5.5-5 | 2.5 | 5.5 | 10 |

11. OPTIONS AND AUXILIARY EQUIPMENT

2) Control circuit terminal

POINT

● Under tightening can cause a cable disconnection or malfunction. Over tightening can cause a short circuit or malfunction due to damage to the screw or the brake unit.



Terminal block

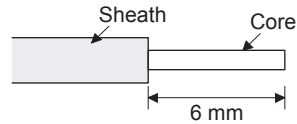

Wire the stripped cable after twisting to prevent the cable from becoming loose. In addition, do not solder it.

Screw size: M3

Tightening torque: 0.5 to 0.6 [N•m]

Wire size: 0.3 mm² to 0.75 mm²

Screw driver: Small flat-blade screwdriver

(Tip thickness: 0.4 mm/Tip width 2.5 mm)

(b) Cables for connecting the servo amplifier and a distribution terminal block when connecting two sets of the brake unit

| Brake unit | Wire size | |
|------------|-----------------------------|-----|
| | HIV wire [mm ²] | AWG |
| FR-BU2-15K | 8 | 8 |

(4) Crimp terminals for P+ and N- terminals of servo amplifier

(a) Recommended crimp terminals

POINT

● Always use recommended crimp terminals or equivalent since some crimp terminals cannot be installed depending on the size.

| Servo amplifier | | Brake unit | Number of connected units | Crimp terminal (Manufacturer) | (Note 1) Applicable tool |
|-----------------|------------|------------|---------------------------|-------------------------------|--------------------------|
| 200 V class | MR-J4-500A | FR-BU2-15K | 1 | FVD5.5-S4(JST) | a |
| | | | 2 | 8-4NS(JST) (Note 2) | b |
| | MR-J4-700A | FR-BU2-30K | 1 | FVD5.5-S4(JST) | a |
| | | | 2 | 8-4NS(JST) (Note 2) | b |
| | | FR-BU2-30K | 1 | FVD5.5-S4(JST) | a |

Note 1. Symbols in the applicable tool field indicate applicable tools in (4)(b) of this section.
 2. Coat the crimping part with an insulation tube.

11. OPTIONS AND AUXILIARY EQUIPMENT

(b) Applicable tool

| Symbol | Servo amplifier-side crimp terminals | | |
|--------|--------------------------------------|-----------------|--------------|
| | Crimp terminal | Applicable tool | Manufacturer |
| a | FVD5.5-S4 FVD5.5-6 | YNT-1210S | JST |
| b | 8-4NS | YHT-8S | |

11.3.4 Dimensions

(1) FR-BU2 Brake unit

[Unit: mm]

FR-BU2-15K

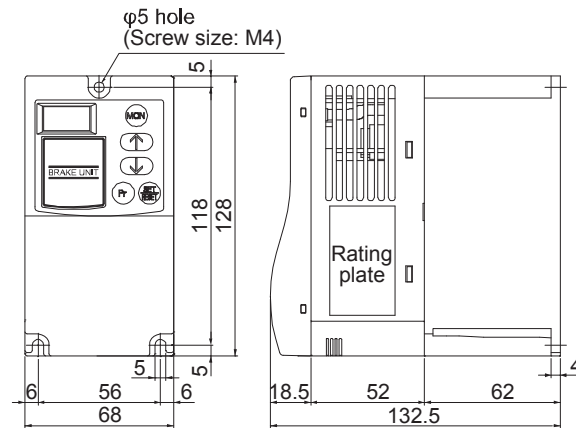

FR-BU2-30K

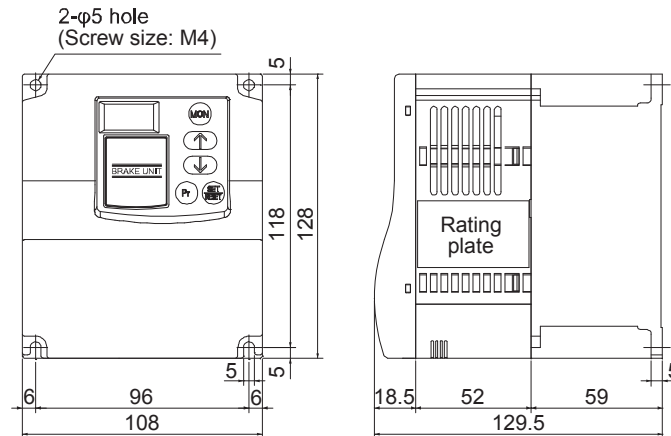

11. OPTIONS AND AUXILIARY EQUIPMENT

(2) FR-BR Resistor unit

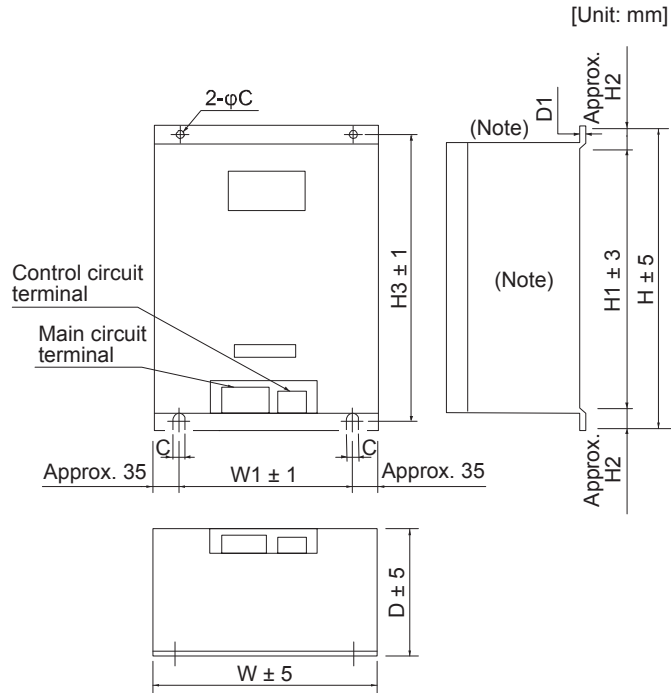

Note. Ventilation ports are provided on both sides and the top. The bottom is open.

| | Resistor unit | W | W1 | H | H1 | H2 | H3 | D | D1 | C | Approximate mass [kg] |
|-------------|---------------|-----|-----|-----|-----|----|-----|-----|-----|----|-----------------------|
| 200 V class | FR-BR-15K | 170 | 100 | 450 | 410 | 20 | 432 | 220 | 3.2 | 6 | 15 |
| | FR-BR-30K | 340 | 270 | 600 | 560 | 20 | 582 | 220 | 4 | 10 | 30 |

11.4 FR-RC Power regenerative converter

| POINT |
|---|
| ● When using FR-RC, set [Pr. PA04] to "0 0 __" to enable EM1 (Forced stop 1). |

When using the power regenerative converter, set "__ 0 1" in [Pr. PA02].

(1) Selection example

The converters can continuously return 75% of the nominal regenerative power. They are applied to the servo amplifiers of the 5 kW to 7 kW.

| Power regenerative converter | Nominal regenerative power [kW] | Servo amplifier |
|------------------------------|---------------------------------|-----------------|
| FR-RC-15K | 15 | MR-J4-500A |
| FR-RC-30K | 30 | MR-J4-700A |

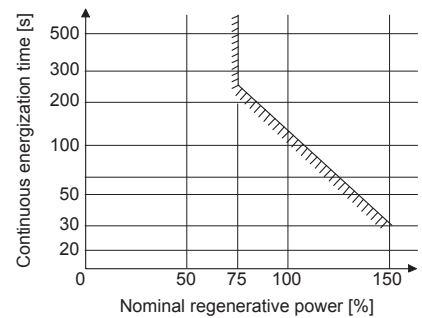

11. OPTIONS AND AUXILIARY EQUIPMENT

(2) Connection example

POINT
 ● In this configuration, only the STO function is supported. The forced stop deceleration function is not available.

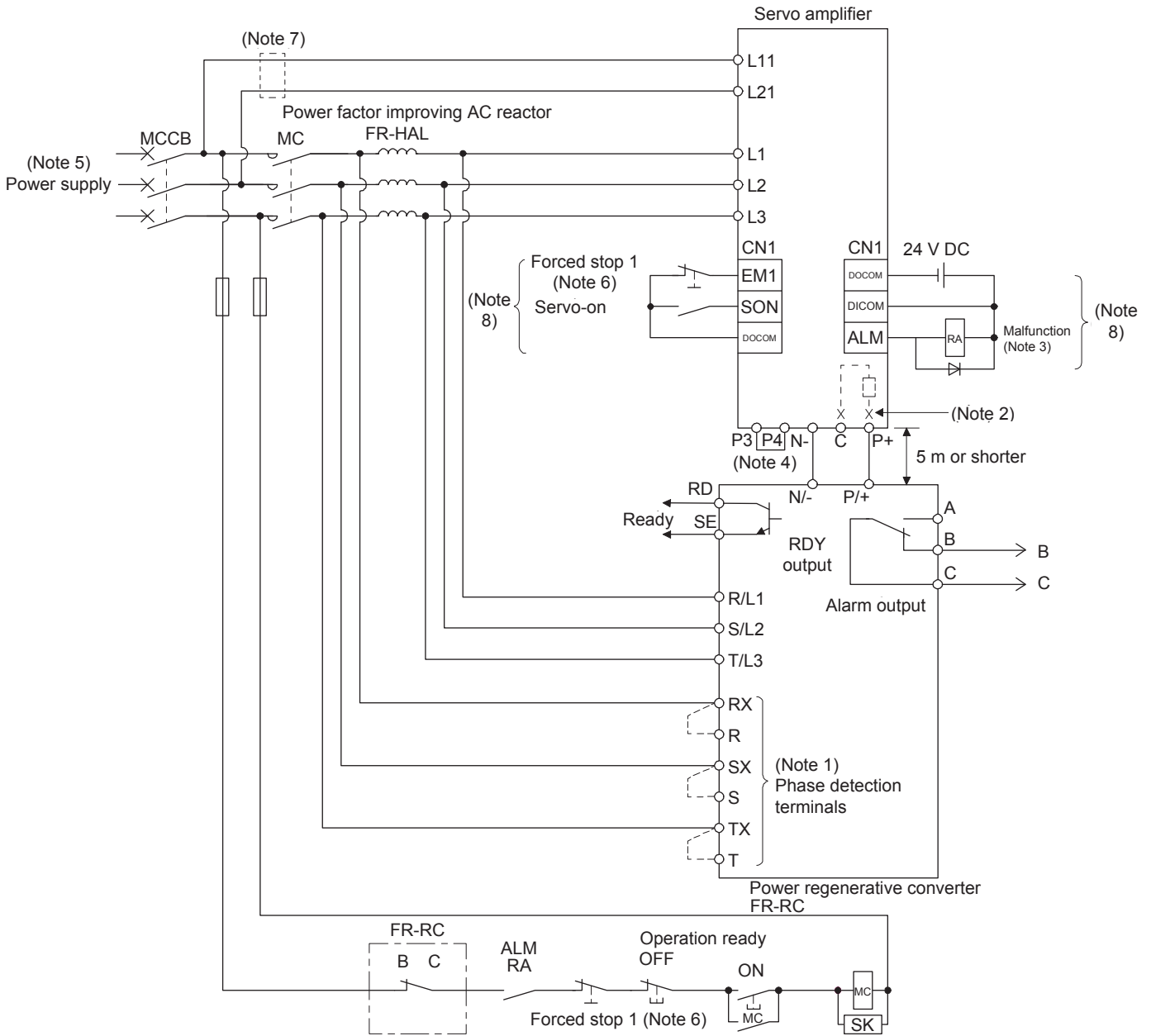

11. OPTIONS AND AUXILIARY EQUIPMENT

- Note
- When not using the phase detection terminals, fit the jumpers across RX-R, SX-S and TX-T. If the jumpers remain removed, the FR-RC will not operate.
 - For the servo amplifier of 7 kW, always disconnect the lead wire of built-in regenerative resistor, which is connected to the P+ 3. and C terminals.
 - If disabling ALM (Malfunction) output with the parameter, configure up the power supply circuit which switches off the magnetic contactor after detection of alarm occurrence on the controller side.
 - Always connect between P3 and P4 terminals. (factory-wired) Use either the power factor improving DC reactor or the power factor improving AC reactor. When using the power factor improving DC reactor, refer to section 11.11.
 - For power supply specifications, refer to section 1.3.
 - Set [Pr. PA04] to "0 0 __" to enable EM1 (Forced stop 1). Configure up the circuit which shuts off main circuit power with external circuit at EM1 (Forced stop 1) off.
 - When wires used for L11 and L21 are thinner than wires used for L1, L2, and L3, use a molded case circuit breaker.
 - This diagram is for sink I/O interface. For source I/O interface, refer to section 3.9.3.

(3) Dimensions

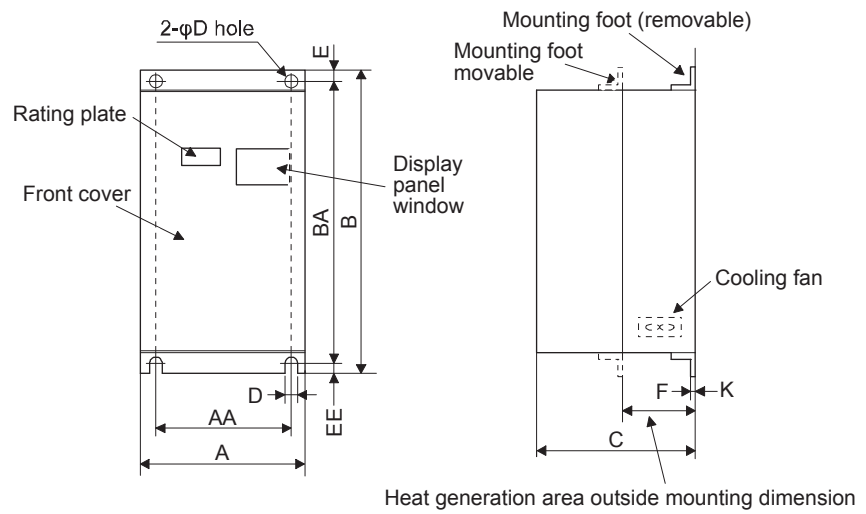

[Unit: mm]

| Power regenerative converter | A | AA | B | BA | C | D | E | EE | K | F | Approximate mass [kg] |
|------------------------------|-----|-----|-----|-----|-----|----|----|----|-----|----|-----------------------|
| FR-RC-15K | 270 | 200 | 450 | 432 | 195 | 10 | 10 | 8 | 3.2 | 87 | 19 |
| FR-RC-30K | 340 | 270 | 600 | 582 | 195 | 10 | 10 | 8 | 3.2 | 90 | 31 |

11. OPTIONS AND AUXILIARY EQUIPMENT

(4) Mounting hole machining dimensions

When the power regenerative converter is installed to an enclosed type cabinet, mount the heat generating area of the converter outside the box to provide heat generation measures. At this time, the mounting hole having the following dimensions is machined in the box.

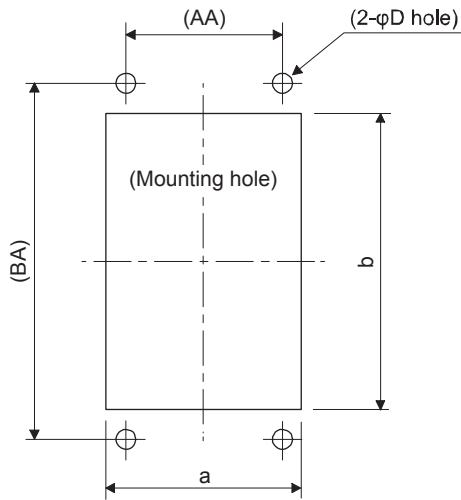

[Unit: mm]

| Power regenerative converter | a | b | D | AA | BA |
|------------------------------|-----|-----|----|-----|-----|
| FR-RC-15K | 260 | 412 | 10 | 200 | 432 |
| FR-RC-30K | 330 | 562 | 10 | 270 | 582 |

11. OPTIONS AND AUXILIARY EQUIPMENT

11.5 FR-CV Power regenerative common converter

| POINT |
|---|
| <ul style="list-style-type: none"> ● For details of the power regenerative common converter FR-CV, refer to the FR-CV-(H) Installation Guide (IB(NA)0600075). ● Do not supply power to the main circuit power supply terminals (L1, L2, and L3) of the servo amplifier. Doing so will fail the servo amplifier and FR-CV. ● Connect the DC power supply between the FR-CV and servo amplifier with correct polarity. Connection with incorrect polarity will fail the FR-CV and servo amplifier. ● Two or more FR-CV's cannot be installed to improve regeneration capability. Two or more FR-CV's cannot be connected to the same DC power supply line. ● When using FR-CV, set [Pr. PA04] to "0 0 __" to enable EM1 (Forced stop 1). |

When using the power regenerative common converter, set [Pr. PA02] to "__ 0 1".

(1) Model

FR-CV-7.5K

└── Capacity

| Symbol | Capacity [kW] |
|--------|---------------|
| 7.5K | 7.5 |
| 11K | 11 |
| 15K | 15 |
| 22K | 22 |
| 30K | 30 |
| 37K | 37 |
| 55K | 55 |

(2) Selection example

The power regenerative common converter FR-CV can be used for the servo amplifier of 200 V class with 750 W to 7 kW. The following shows the restrictions on using the FR-CV.

- (a) Up to six servo amplifiers can be connected to one FR-CV.
- (b) $\text{FR-CV capacity [W]} \geq \text{Total of rated capacities [W]} \times 2$ of servo amplifiers connected to FR-CV.
- (c) The total of used servo motor rated currents should be equal to or less than the applicable current [A] of the FR-CV.
- (d) Among the servo amplifiers connected to the FR-CV, the servo amplifier of the maximum capacity should be equal to or less than the maximum connectable capacity [W].

The following table lists the restrictions.

| Item | FR-CV-__ | | | | | | |
|--|----------|-----|-----|-----|-----|------|------|
| | 7.5K | 11K | 15K | 22K | 30K | 37K | 55K |
| Maximum number of connected servo amplifiers | 6 | | | | | | |
| Total of connectable servo amplifier capacities [kW] | 3.75 | 5.5 | 7.5 | 11 | 15 | 18.5 | 27.5 |
| Total of connectable servo motor rated currents [A] | 33 | 46 | 61 | 90 | 115 | 145 | 215 |
| Maximum servo amplifier capacity [kW] | 3.5 | 5 | 7 | 11 | 15 | 15 | 22 |

11. OPTIONS AND AUXILIARY EQUIPMENT

When using the FR-CV, always install the dedicated stand-alone reactor (FR-CVL).

| Power regenerative common converter | Dedicated stand-alone reactor |
|-------------------------------------|-------------------------------|
| FR-CV-7.5K(-AT) | FR-CVL-7.5K |
| FR-CV-11K(-AT) | FR-CVL-11K |
| FR-CV-15K(-AT) | FR-CVL-15K |
| FR-CV-22K(-AT) | FR-CVL-22K |
| FR-CV-30K(-AT) | FR-CVL-30K |
| FR-CV-37K | FR-CVL-37K |
| FR-CV-55K | FR-CVL-55K |

(3) Connection diagram

POINT

● In this configuration, only the STO function is supported. The forced stop deceleration function is not available.

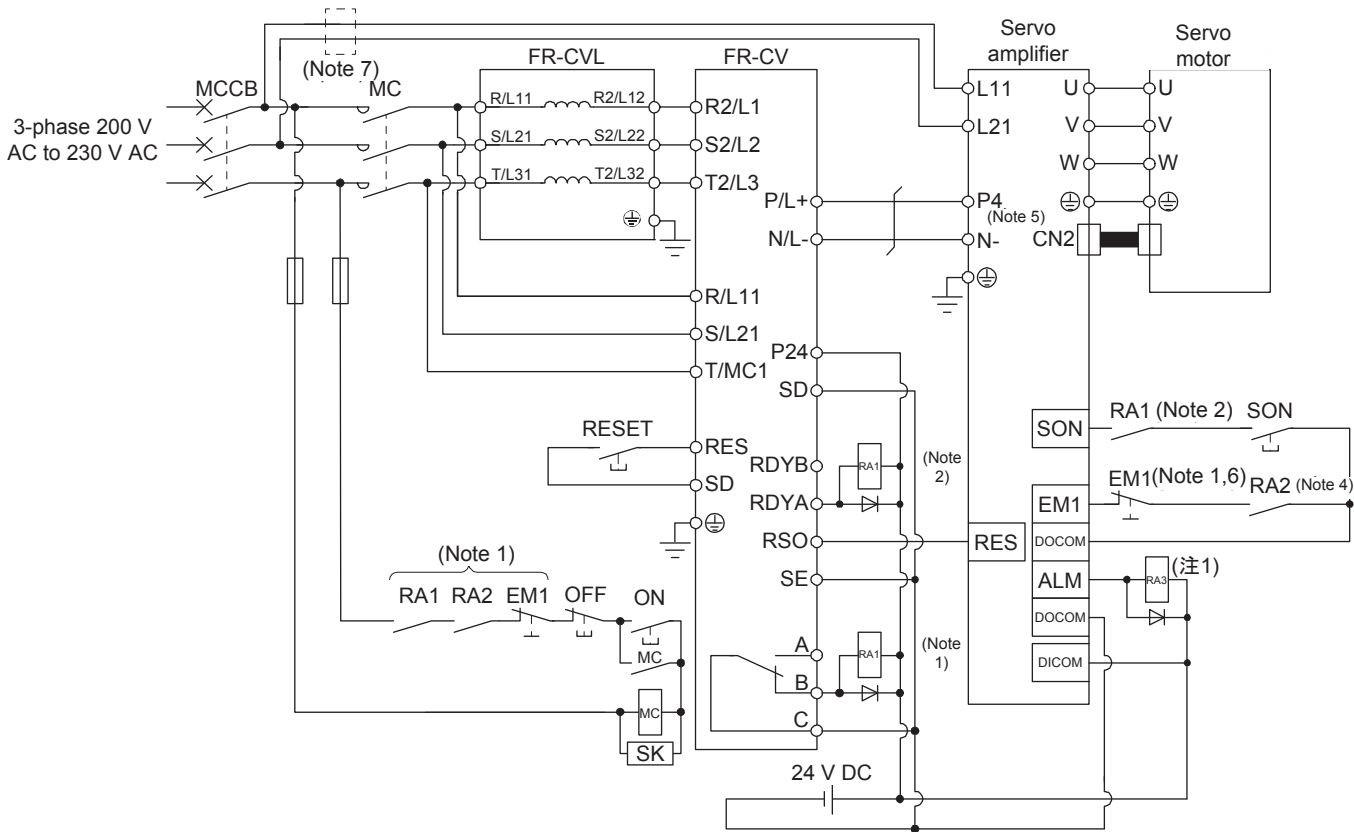

11. OPTIONS AND AUXILIARY EQUIPMENT

- Note
1. Configure a sequence that will shut off main circuit power at the follow cases.
 - FR-CV or servo amplifier alarm occurs.
 - EM1 (forced stop 1) turns off.
 2. For the servo amplifier, configure a sequence that will switch the servo-on after the FR-CV is ready.
 3. For the FR-CV, the RSO signal turns off when it is put in a ready-to-operate status where the reset signal is input. Configure a sequence that will make the servo inoperative when the RSO signal is on.
 4. Configure a sequence that will make a stop with the emergency stop input of the servo system controller if an alarm occurs in the FR-CV.
 5. When using the FR-CV, disconnect between P3 and P4 terminals.
 6. Set [Pr. PA04] to "0 0 __" to enable EM1 (Forced stop 1).
 7. When wires used for L11 and L21 are thinner than wires used for L1, L2, and L3, use a molded case circuit breaker.

(4) Selection example of wires used for wiring

| |
|--|
| POINT |
| <ul style="list-style-type: none"> ● Selection condition of wire size is as follows. <ul style="list-style-type: none"> Wire type: 600 V Polyvinyl chloride insulated wire (IV wire) Construction condition: One wire is constructed in the air. |

(a) Wire sizes

1) Across P - P4, N - N

The following table indicates the connection wire sizes of the DC power supply (P4, N- terminals) between the FR-CV and servo amplifier.

| Total of servo amplifier capacities [kW] | Wires [mm ²] |
|--|--------------------------|
| 1 or less | 2 |
| 2 | 3.5 |
| 5 | 5.5 |
| 7 | 8 |
| 11 | 14 |
| 15 | 22 |
| 22 | 50 |

2) Grounding

For grounding, use the wire of the size equal to or greater than that indicated in the following table, and make it as short as possible.

| Power regenerative common converter | Grounding wire size [mm ²] |
|-------------------------------------|--|
| FR-CV-7.5K to FR-CV-15K | 14 |
| FR-CV-22K, FR-CV-30K | 22 |
| FR-CV-37K, FR-CV-55K | 38 |

11. OPTIONS AND AUXILIARY EQUIPMENT

(b) Example of selecting the wire sizes

When connecting multiple servo amplifiers, always use junction terminals for wiring the servo amplifier terminals P4, N-. Also, connect the servo amplifiers in the order of larger to smaller capacities.

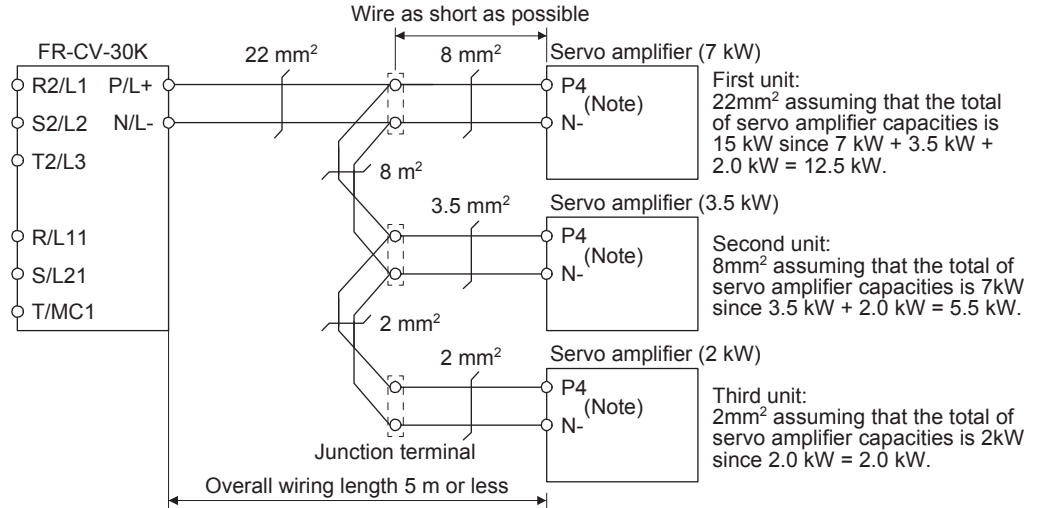

Note. When using the servo amplifier of 7 kW or less, make sure to disconnect the wiring of built-in regenerative resistor (5 kW or less: P4 and D, 7 kW to 7 kW: P4 and C).

11. OPTIONS AND AUXILIARY EQUIPMENT

(5) Other precautions

- (a) Always use the dedicated stand-alone reactor (FR-CVL) as the power factor improving reactor. Do not use the power factor improving AC reactor (FR-HAL) or Power factor improving DC reactor (FR-HEL).
- (b) The inputs/outputs (main circuits) of the FR-CV and servo amplifiers include high-frequency components and may provide electromagnetic wave interference to communication equipment (such as AM radios) used near them. In this case, interference can be reduced by installing the radio noise filter (FR-BIF) or line noise filter (FR-BSF01, FR-BLF).
- (c) The overall wiring length for connection of the DC power supply between the FR-CV and servo amplifiers should be 5 m or less, and the wiring must be twisted.

(6) Specifications

| Power regenerative common converter FR-CV- <u> </u> | | 7.5K | 11K | 15K | 22K | 30K | 37K | 55K |
|---|---|--|--|----------------|-----------------|-----------------|-----------------|-----------------|
| Item | | | | | | | | |
| Total of connectable servo amplifier capacities [kW] | | 3.75 | 5.5 | 7.5 | 11 | 15 | 18.5 | 27.5 |
| Maximum servo amplifier capacity [kW] | | 3.5 | 5 | 7 | 11 | 15 | 15 | 22 |
| Output | Total of connectable servo motor rated currents [A] | 33 | 46 | 61 | 90 | 115 | 145 | 215 |
| | Regenerative braking torque | Short-time rating | Total capacity of applicable servo motors, 300% torque, 60s (Note 1) | | | | | |
| | | Continuous rating | 100% torque | | | | | |
| Power supply | Rated input AC voltage/frequency | 3-phase 200 V AC to 220 V AC 50 Hz, 200 V AC to 230 V AC 60 Hz | | | | | | |
| | Permissible AC voltage fluctuation | 3-phase 170 V AC to 242 V AC 50 Hz, 170 V AC to 253 V AC 60 Hz | | | | | | |
| | Permissible frequency fluctuation | ±5% | | | | | | |
| | Power supply capacity [kVA] (Note 2) | 17 | 20 | 28 | 41 | 52 | 66 | 100 |
| IP rating (JEM 1030), cooling method | | Open type (IP00), forced cooling | | | | | | |
| Environment | Ambient temperature | -10 °C to 50 °C (non-freezing) | | | | | | |
| | Ambient humidity | 90% RH or less (non-condensing) | | | | | | |
| | Ambience | Indoors (no direct sunlight), free from corrosive gas, flammable gas, oil mist, dust, and dirt | | | | | | |
| Altitude, vibration | | 1000 m or less above sea level, 5.9 m/s ² or less | | | | | | |
| Molded case circuit breaker or leakage current breaker | | 30 AF 30 A | 50 AF 50 A | 100 AF 75 A | 100 AF 100 A | 225 AF 125 A | 225 AF 125 A | 225 AF 175 A |
| Magnetic contactor | | S-N20 | S-N35 | S-N50 | S-N65 | S-N95 | S-N95 | S-N125 |

Note 1. This is the time when the protective function of the FR-CV is activated. The protective function of the servo amplifier is

2. activated in the time indicated in section 10.1.

When connecting the capacity of connectable servo amplifier, specify the value of servo amplifier.

11. OPTIONS AND AUXILIARY EQUIPMENT

11.6 Junction terminal block MR-TB50

(1) Usage

Always use the junction terminal block (MR-TB50) with the option cable (MR-J2M-CN1TBL_M) as a set.

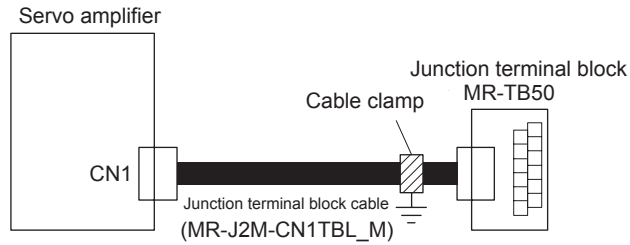

Ground the option cable on the junction terminal block side with the cable clamp fitting (AERSBAN-ESET). For the use of the cable clamp fitting, refer to section 11.14, (2)(c).

(2) Terminal labels

Use the following junction terminal block labels. This label is supplied with the junction terminal block MR-TB50.

Position control mode

| | | | | | | | | | | | | | | | | | | | | |
|---|------|----|-----|-----|-----|----|-------|-----|-----|-------|-----|-----|-----|-----|-----|-------|-----|-----|-------|----|
| 1 | P15R | LG | LAR | LBR | LZR | PG | SON | PC | RES | DICOM | ZSP | TLC | TLA | OP | NP | CR | LSP | LOP | DOCOM | RD |
| 2 | LA | LB | LZ | PP | OPC | TL | DICOM | INP | INP | LG | LG | LG | NG | EMG | LSN | DOCOM | ALM | SD | | |

Speed control mode

| | | | | | | | | | | | | | | | | | | |
|---|------|----|-----|-----|-----|-----|-------|-----|-------|-----|-----|-----|-----|-----|-------|-----|-------|----|
| 1 | P15R | LG | LAR | LBR | LZR | SON | ST1 | RES | DICOM | ZSP | TLC | TLA | OP | SP1 | LSP | LOP | DOCOM | RD |
| 2 | VC | LA | LB | LZ | SP2 | ST2 | DICOM | SA | SA | LG | LG | LG | EMG | LSN | DOCOM | ALM | SD | |

Torque control mode

| | | | | | | | | | | | | | | | | | |
|---|------|----|-----|-----|-----|-----|-------|-----|-------|-----|-----|-------|-----|-----|-----|-------|----|
| 1 | P15R | LG | LAR | LBR | LZR | SON | SR2 | RES | DICOM | ZSP | VLC | TC | OP | SP1 | LOP | DOCOM | RD |
| 2 | VLA | LA | LB | LZ | SP2 | RS1 | DICOM | LG | LG | LG | EMG | DOCOM | ALM | SD | | | |

(3) Dimensions

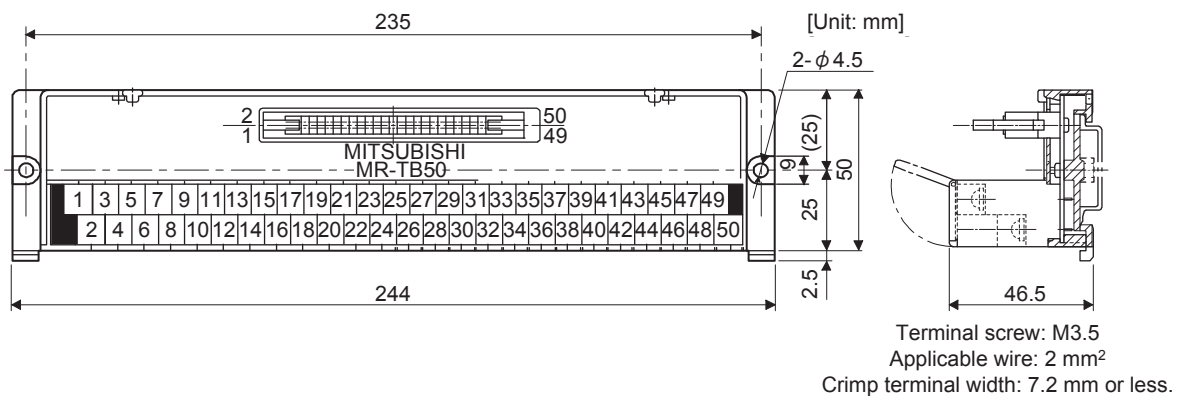

11. OPTIONS AND AUXILIARY EQUIPMENT

(4) Junction terminal block cable MR-J2M-CN1TBL_M

(a) Model explanations

Model: MR-J2M-CN1TBL_M

| Symbol | Cable length [m] |
|--------|------------------|
| 05 | 0.5 |
| 1 | 1 |

(b) Connection diagram

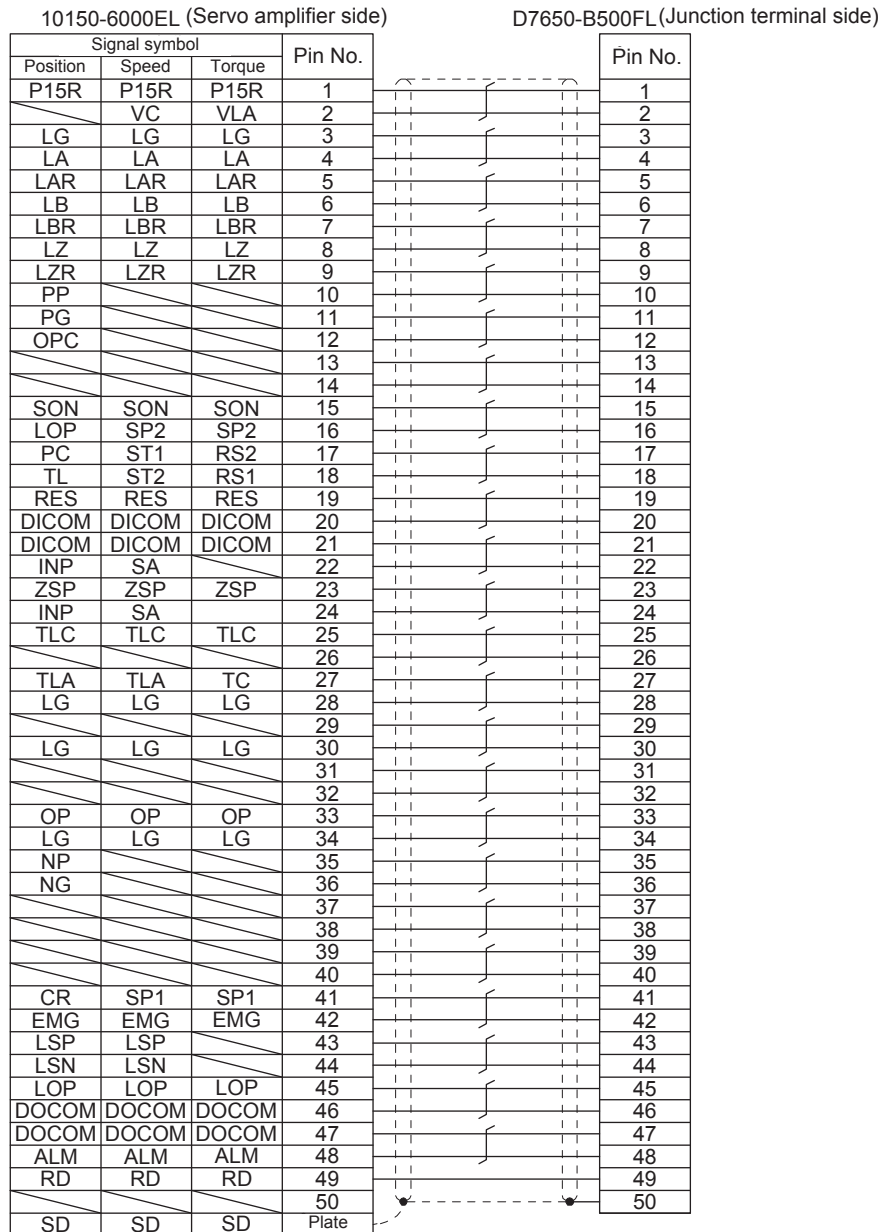

11. OPTIONS AND AUXILIARY EQUIPMENT

11.7 MR Configurator2

MR Configurator2 (SW1DNC-MRC2-E) uses the communication function of the servo amplifier to perform parameter setting changes, graph display, test operation, etc. on a personal computer.

(1) Specifications

| Item | Description |
|----------------|--|
| Project | Creat/read/save/delete project, system setting, and print |
| Parameter | Parameter setting |
| Monitor | Display all, I/O monitor, graph, and ABS data display |
| Diagnostic | Alarm display, alarm onset data, drive recorder, no motor rotation, system configuration, life diagnosis, machine diagnosis, fully closed loop diagnosis, and linear diagnosis |
| Test operation | Jog operation, positioning operation, motor-less operation (Note), DO forced output, and program operation |
| Adjustment | One-touch tuning, tuning, and machine analyzer |
| Others | Servo assistant, parameter setting range update, machine unit conversion setting, help display, and connection to MELFANSweb |

Note. This function is available only with rotary servo motors. It will be available with linear servo motors and direct drive motors in the future.

(2) System configuration

(a) Components

To use this software, the following components are required in addition to the servo amplifier and servo motor.

| Equipment | (Note 1) Description |
|--|--|
| (Note 2, 3, 4, 5) Personal computer | OS Microsoft® Windows® 7 Ultimate [Service Pack none/1] Microsoft® Windows® 7 Enterprise [Service Pack none/1] Microsoft® Windows® 7 Professional [Service Pack none/1] Microsoft® Windows® 7 Home Premium [Service Pack none/1] Microsoft® Windows® 7 Starter [Service Pack none/1] Microsoft® Windows Vista® Home Basic [Service Pack none/1/2] Microsoft® Windows Vista® Home Premium [Service Pack none/1/2] Microsoft® Windows Vista® Business [Service Pack none/1/2] Microsoft® Windows Vista® Ultimate [Service Pack none/1/2] Microsoft® Windows Vista® Enterprise [Service Pack none /1/2] Microsoft® Windows® XP Professional [Service Pack 2/3] Microsoft® Windows® XP Home Edition [Service Pack 2/3] Microsoft® Windows® 2000 Professional [Service Pack 4] |
| | CPU Desktop personal computer: Intel® Celeron® processor 2.8GHz or more is recommended. Laptop personal computer: Intel® Pentium® M processor 1.7GHz or more is recommended. |
| | Memory 512 MB or more (for 32-bit OS) and 1GB or more (for 64-bit OS) |
| | Hard Disk 1GB or more of free space |
| | Communication interface USB port |
| | Browser Internet Explorer 4.0 or more |
| Display One whose resolution is 1024 × 768 or more and that can provide a high color (16 bit) display. Connectable with the above personal computer. | |
| Keyboard Connectable with the above personal computer. | |
| Mouse Connectable with the above personal computer. | |
| Printer Connectable with the above personal computer. | |
| USB cable MR-J3USBCBL3M | |

11. OPTIONS AND AUXILIARY EQUIPMENT

Note 1. Windows and Windows Vista are registered trademarks of Microsoft Corporation in the United States and/or other countries. Celeron and Pentium are the registered trademarks of Intel Corporation.

2. On some personal computers, MR Configurator2 may not run properly.

3. When Microsoft® Windows® 7, Microsoft® Windows Vista®, or Microsoft® Windows® XP is used, the following functions cannot be used.

- Windows Program Compatibility mode
- Fast User Switching
- Remote Desktop
- Large Fonts Mode (Display property)
- DPI settings other than 96DPI (Display property)

For 64-bit operating system, this software is compatible with Windows® 7.

4. When Windows® 7 is used, the following functions cannot be used.

- Windows XP Mode
- Windows touch

5. When using this software with Windows Vista® and Windows® 7, log in as a user having USER authority or higher.

(b) Connection with servo amplifier

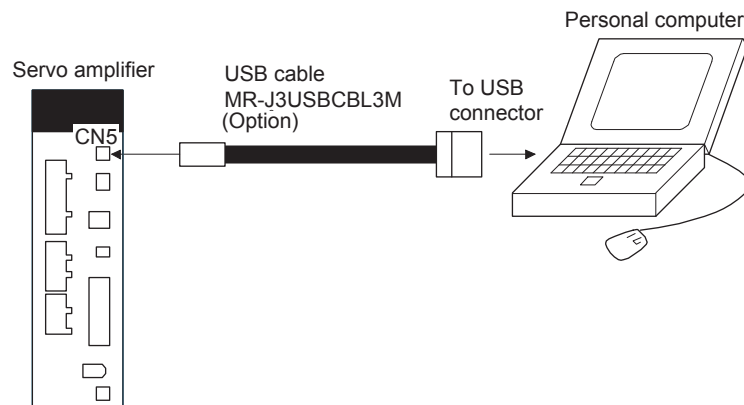

11. OPTIONS AND AUXILIARY EQUIPMENT

11.8 Battery

| |
|--|
| POINT |
| ● Refer to appendix 2 and 3 for battery transportation and the new EU Battery Directive. |

(1) Purpose of use for MR-BAT6V1SET

This battery is used to construct an absolute position detection system. Refer to section 12.3 for the fitting method, etc.

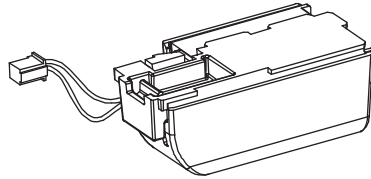

(2) Year and month when MR-BAT6V1SET is manufactured

The manufacturing years of MR-BAT6V1SET have been described to the rating plate put on a built-in MR-BAT6V1 battery.

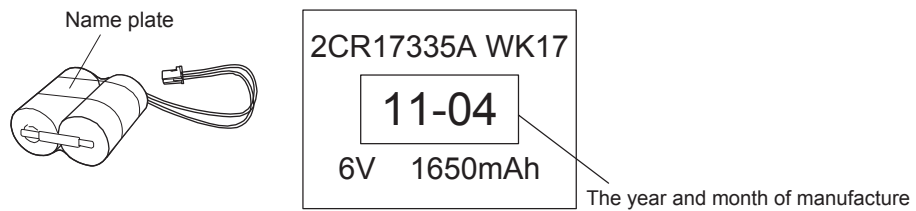

11. OPTIONS AND AUXILIARY EQUIPMENT

11.9 Selection example of wires

| POINT |
|--|
| <ul style="list-style-type: none"> ● To comply with the UL/CSA standard, use the wires shown in appendix 5 for wiring. To comply with other standards, use a wire that is complied with each standard. ● Selection condition of wire size is as follows. Construction condition: One wire is constructed in the air. Wire length: 30 m or less |

The following diagram shows the wires used for wiring. Use the wires given in this section or equivalent.

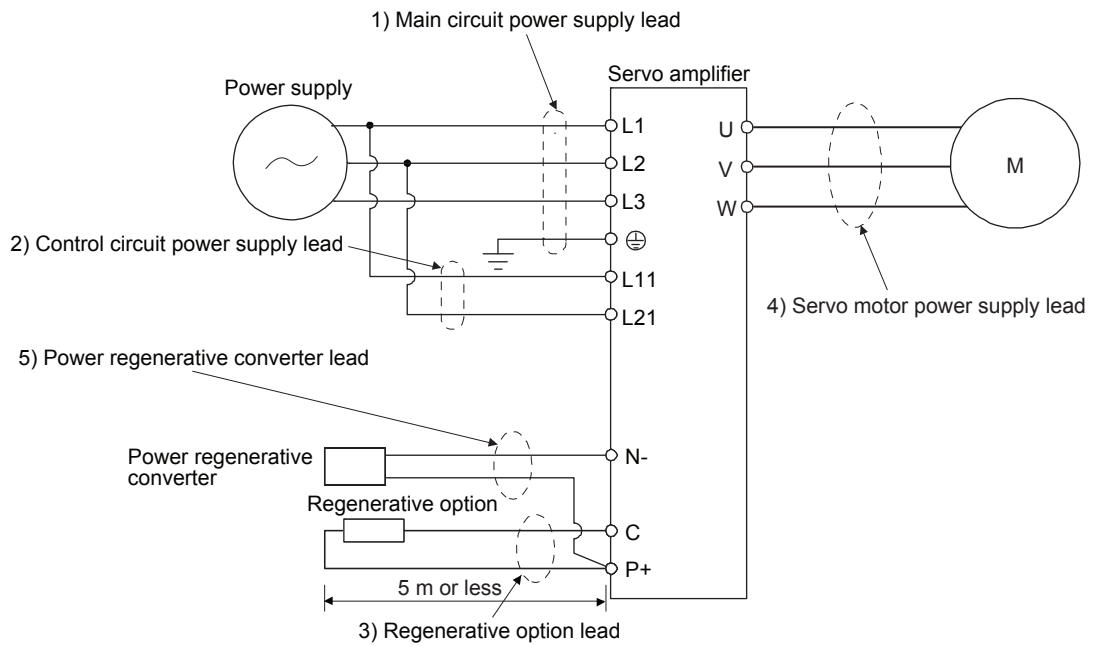

11. OPTIONS AND AUXILIARY EQUIPMENT

- (1) When using the 600 V Grade heat-resistant polyvinyl chloride insulated wire (HIV wire)
Selection example of wire size when using HIV wires is indicated below.

Table 11.1 Wire size selection example 1 (HIV wire)

| Servo amplifier | Wires [mm ²] | | | |
|---------------------|--------------------------|---|---------------|--|
| | 1) L1/L2/L3/⊕ | 2) L11/L21 | 3) P+/C/D | 4) U/V/W/⊕ (Note 3) |
| MR-J4-10A | 2 (AWG 14) | 1.25 to 2(AWG 16 to 14) (Note 4) | 2 (AWG 14) | AWG 18 to 14 (Note 4) |
| MR-J4-20A | | | | |
| MR-J4-40A | | | | |
| MR-J4-60A | | | | |
| MR-J4-70A | | | | |
| MR-J4-100A | | | | |
| MR-J4-200A | | | | |
| MR-J4-350A | 3.5 (AWG 12) | | | AWG 16 to 10 |
| MR-J4-500A (Note 2) | 5.5 (AWG 10): a | 1.25 (AWG 16): a 2 (AWG 14): d (Note 4) | 2 (AWG 14): c | 2 (AWG 14): c 3.5 (AWG 12): a 5.5 (AWG 10): a |
| MR-J4-700A (Note 2) | 8 (AWG 14): b | | | 2 (AWG 14): c 3.5 (AWG 12): a 5.5 (AWG 10): a 8 (AWG 14): b |

- Note 1. Alphabets in the table indicate crimping tools. For crimp terminals and applicable tools, refer to (2) in this section.
2. To connect these models to a terminal block, be sure to use the screws that come with the
3. terminal block.
The wire size shows applicable size of the servo amplifier connector. For wires connecting to the
4. servo motor, refer to each servo amplifier instruction manual.
Be sure to use 2 mm² when corresponding to EN standard.

Use wires 5) of the following sizes with the power regenerative converter (FR-RC).

| Model | Wires [mm ²] |
|-----------|--------------------------|
| FR-RC-15K | 14 (AWG 6) |
| FR-RC-30K | 14 (AWG 6) |
| FR-RC-55K | 22 (AWG 4) |

- (2) Selection example of crimp terminals

The table below shows a selection example of crimp terminals for the servo amplifier terminal block.

| Symbol | Servo amplifier-side crimp terminals | | |
|---------------|--------------------------------------|-----------------|--------------|
| | (Note 2) Crimp terminals | Applicable tool | Manufacturer |
| a | FVD5.5-4 | YNT-1210S | JST |
| (Note 1) b | 8-4NS | YHT-8S | |
| c | FVD2-4 | YNT-1614 | |
| d | FVD2-M3 | | |
| e | FVD1.25-M3 | YNT-2216 | |

- Note 1. Coat the crimping part with an insulation tube.
2. Always use recommended crimp terminals or equivalent since some crimp terminals cannot be installed depending on the size.

11. OPTIONS AND AUXILIARY EQUIPMENT

11.10 Molded case circuit breakers, fuses, magnetic contactors (recommended)

(1) For main circuit power supply

Always use one molded case circuit breaker and one magnetic contactor with one servo amplifier. When using a fuse instead of the molded case circuit breaker, use the one having the specifications given in this section.

| Servo amplifier | Molded case circuit breaker (Note 1) | | Fuse | | | Magnetic contactor (MC) (Note 2) | |
|-----------------|--------------------------------------|----------------|-------|-------------|----------------|----------------------------------|-------|
| | Frame, rated current | Voltage AC [V] | Class | Current [A] | Voltage AC [V] | | |
| MR-J4-10A | 30 A frame 5 A | 240 | T | 10 | 300 | S-N10 | |
| MR-J4-20A | | | | | | | |
| MR-J4-40A | | | | | | | |
| MR-J4-60A | 30 A frame 10 A | | | 15 | | | |
| MR-J4-70A | | | | | | | |
| MR-J4-100A | 30 A frame 15 A | | | 20 | | | |
| MR-J4-200A | 30 A frame 20 A | | | 40 | | | S-N18 |
| MR-J4-350A | 30 A frame 30 A | | | 70 | | | S-N20 |
| MR-J4-500A | 50 A frame 50 A | | | 125 | | | S-N35 |
| MR-J4-700A | 100 A frame 75 A | | | 150 | | | S-N50 |

- Note 1. When using the servo amplifier as a UL/CSA standard compliant product, refer to appendix 5.
 2. Use a magnetic contactor with an operation delay time (interval between current being applied to the coil until closure of contacts) of 80 ms or less.

(2) For control circuit power supply

When the wiring for the control circuit power supply (L11, L21) is thinner than that for the main circuit power supply (L1, L2, L3), install an overcurrent protection device (molded case circuit breaker or fuse) to protect the branch circuit.

| Servo amplifier | Molded case circuit breaker (Note) | | Fuse (Class T) | | Fuse (Class K5) | |
|-----------------|------------------------------------|----------------|----------------|----------------|-----------------|----------------|
| | Frame, rated current | Voltage AC [V] | Current [A] | Voltage AC [V] | Current [A] | Voltage AC [V] |
| MR-J4-10A | 30 A frame 5 A | 240 | 1 | 300 | 1 | 250 |
| MR-J4-20A | | | | | | |
| MR-J4-40A | | | | | | |
| MR-J4-60A | | | | | | |
| MR-J4-70A | | | | | | |
| MR-J4-100A | | | | | | |
| MR-J4-200A | | | | | | |
| MR-J4-350A | | | | | | |
| MR-J4-500A | | | | | | |
| MR-J4-700A | | | | | | |

Note. When using the servo amplifier as a UL/CSA standard compliant product, refer to appendix 5.

11.11 Power factor improving DC reactors

The following shows the advantages of using power factor improving DC reactor.

- It improves the power factor by increasing the form factor of the servo amplifier's input current.
- It decreases the power supply capacity.
- The input power factor is improved to be about 85%.
- As compared to the power factor improving AC reactor (FR-HAL), it decreases the loss.

When connecting the power factor improving DC reactor to the servo amplifier, always disconnect P3 and P4. If it remains connected, the effect of the power factor improving DC reactor is not produced.

When used, the power factor improving DC reactor generates heat. To release heat, therefore, leave a 10 cm or more clearance at each of the top and bottom, and a 5 cm or more clearance on each side.

11. OPTIONS AND AUXILIARY EQUIPMENT

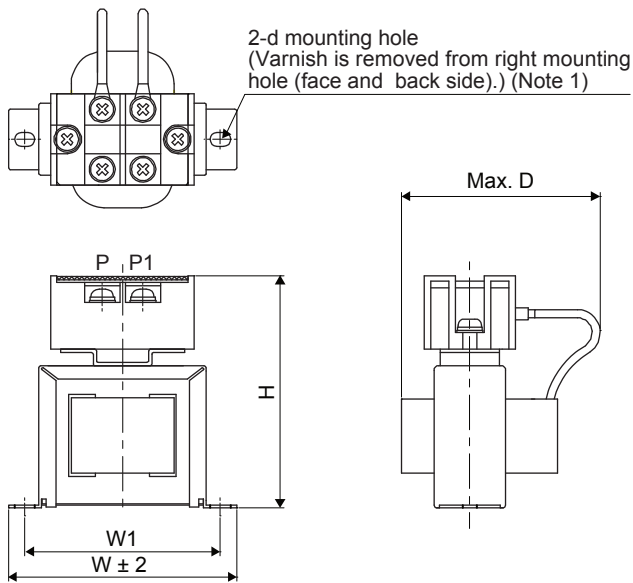

Fig. 11.1

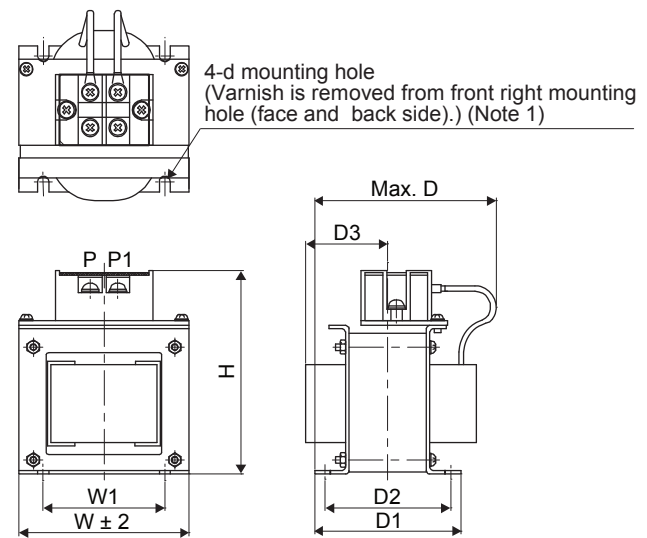
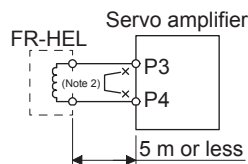

Fig. 11.2



Note 1. Use this for grounding.

2. When using the Power factor improving DC reactor, remove the short bar across P3-P4.

| Servo amplifier | Power factor improving DC reactor | Dimensions | Dimensions [mm] | | | | | | | | Terminal size | Mass [kg] | Wire [mm ²] (Note 2) | | |
|-------------------------|-----------------------------------|------------|-----------------|----|-----|------------|----|----|------|----|---------------|-----------|----------------------------------|--|--------------|
| | | | W | W1 | H | D (Note 1) | D1 | D2 | D3 | d | | | | | |
| MR-J4-10A, MR-J4-20A | FR-HEL-0.4K | Fig. 11.1 | 70 | 60 | 71 | 61 | | 21 | | M4 | M4 | 0.4 | 2 (AWG 14) | | |
| MR-J4-40A | FR-HEL-0.75K | | 85 | 74 | 81 | 61 | | 21 | | M4 | M4 | 0.5 | | | |
| MR-J4-60A, MR-J4-70A | FR-HEL-1.5K | | 85 | 74 | 81 | 70 | | 30 | | M4 | M4 | 0.8 | | | |
| MR-J4-100A | FR-HEL-2.2K | | 85 | 74 | 81 | 70 | | 30 | | M4 | M4 | 0.9 | | | |
| MR-J4-200A | FR-HEL-3.7K | Fig. 11.2 | 77 | 55 | 92 | 82 | 66 | 57 | 37 | M4 | M4 | 1.5 | | | |
| MR-J4-350A | FR-HEL-7.5K | | 86 | 60 | 113 | 98 | 81 | 72 | 43 | M4 | M5 | 2.5 | | | 3.5 (AWG 12) |
| MR-J4-500A | FR-HEL-11K | | 105 | 64 | 133 | 112 | 92 | 79 | 47 | M6 | M6 | 3.3 | | | 5.5 (AWG 10) |
| MR-J4-700A | FR-HEL-15K | | 105 | 64 | 133 | 115 | 97 | 84 | 48.5 | M6 | M6 | 4.1 | | | 8 (AWG 8) |

Note 1. Maximum dimensions The dimension varies depending on the bending degree of the input/output line.

2. Selection condition of wire size is as follows.

600 V grade heat-resistant polyvinyl chloride insulated wire (HIV wire)

Construction condition: One wire is constructed in the air.

11. OPTIONS AND AUXILIARY EQUIPMENT

11.12 Power factor improving AC reactors

The following shows the advantages of using power factor improving AC reactor.

- It improves the power factor by increasing the form factor of the servo amplifier's input current.
- It decreases the power supply capacity.
- The input power factor is improved to be about 80%.

When using power factor improving reactors for two servo amplifiers or more, be sure to connect a power factor improving reactor to each servo amplifier. If using only one power factor improving reactor, enough improvement effect of phase factor cannot be obtained unless all servo amplifiers are operated.

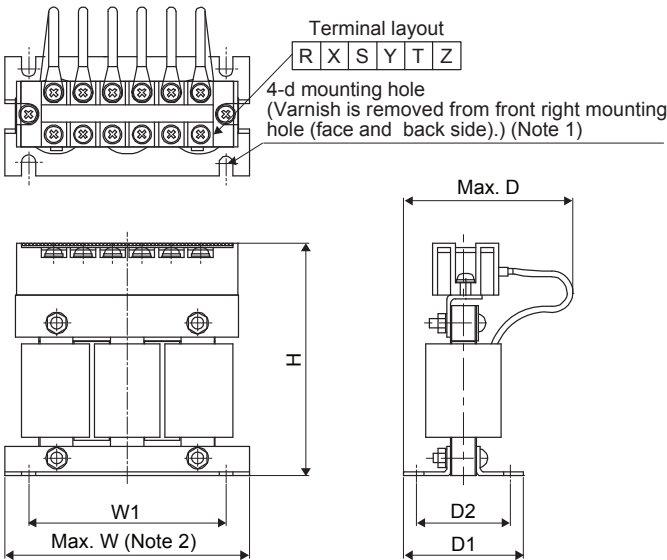
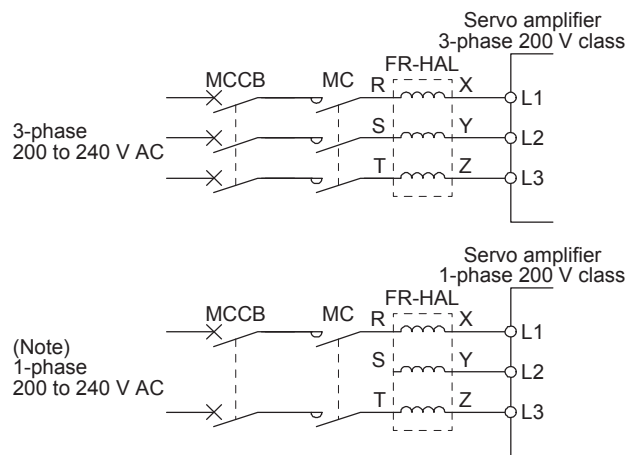

Fig. 11.3

- Note 1. Use this for grounding.
 Note 2. $W \pm 2$ is applicable for FR-HAL-0.4K to 1.5K.



- Note. For 1-phase 200 V AC to 240 V AC, connect the power supply to L1 and L3. Leave L2 open.

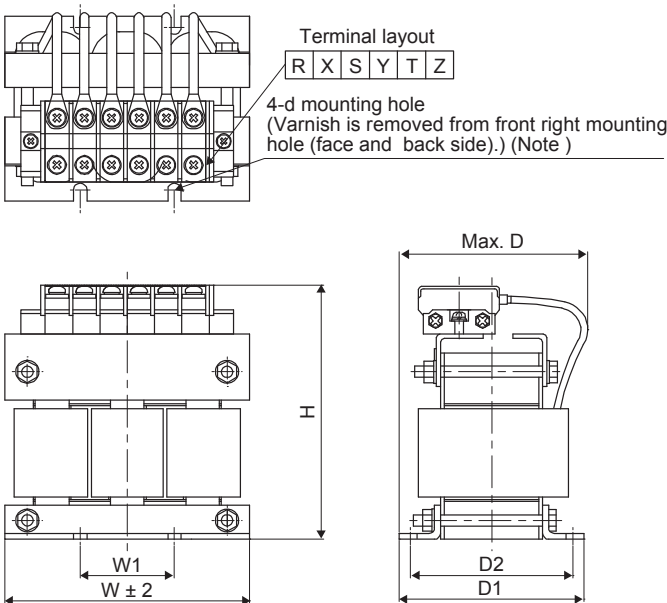

Fig. 11.4

- Note. Use this for grounding.

11. OPTIONS AND AUXILIARY EQUIPMENT

| Servo amplifier | Power factor improving AC reactor | Dimensions | Dimensions [mm] | | | | | | | Terminal size | Mass [kg] |
|-------------------------|-----------------------------------|------------|-----------------|----|-----|----------|-----|-----|----|---------------|-----------|
| | | | W | W1 | H | D (Note) | D1 | D2 | d | | |
| MR-J4-10A, MR-J4-20A | FR-HAL-0.4K | Fig. 11.3 | 104 | 84 | 99 | 72 | 51 | 40 | M5 | M4 | 0.6 |
| MR-J4-40A | FR-HAL-0.75K | | 104 | 84 | 99 | 74 | 56 | 44 | M5 | M4 | 0.8 |
| MR-J4-60A, MR-J4-70A | FR-HAL-1.5K | | 104 | 84 | 99 | 77 | 61 | 50 | M5 | M4 | 1.1 |
| MR-J4-100A | FR-HAL-2.2K | | 115 (Note) | 40 | 115 | 77 | 71 | 57 | M6 | M4 | 1.5 |
| MR-J4-200A | FR-HAL-3.7K | | 115 (Note) | 40 | 115 | 83 | 81 | 67 | M6 | M4 | 2.2 |
| MR-J4-350A | FR-HAL-7.5K | Fig. 11.4 | 130 | 50 | 135 | 100 | 98 | 86 | M6 | M5 | 4.2 |
| MR-J4-500A | FR-HAL-11K | | 160 | 75 | 164 | 111 | 109 | 92 | M6 | M6 | 5.2 |
| MR-J4-700A | FR-HAL-15K | | 160 | 75 | 167 | 126 | 124 | 107 | M6 | M6 | 7.0 |

Note. Maximum dimensions The dimension varies depending on the bending degree of the input/output line.

11.13 Relays (recommended)

The following relays should be used with the interfaces

| Interface | Selection example |
|--|---|
| Digital input (interface DI-1) Relay used for digital input command signals | To prevent defective contacts , use a relay for small signal(twin contacts). (Ex.) Omron : type G2A , MY |
| Digital output (interface DO-1) Relay used for digital output signals | Small relay with 12 V DC or 24 V DC of rated current 40 mA or less (Ex.) Omron : type MY |

11. OPTIONS AND AUXILIARY EQUIPMENT

11.14 Noise reduction techniques

Noises are classified into external noises which enter the servo amplifier to cause it to malfunction and those radiated by the servo amplifier to cause peripheral devices to malfunction. Since the servo amplifier is an electronic device which handles small signals, the following general noise reduction techniques are required. Also, the servo amplifier can be a source of noise as its outputs are chopped by high carrier frequencies. If peripheral devices malfunction due to noises produced by the servo amplifier, noise suppression measures must be taken. The measures will vary slightly with the routes of noise transmission.

(1) Noise reduction techniques

(a) General reduction techniques

- Avoid laying power lines (input and output cables) and signal cables side by side or do not bundle them together. Separate power lines from signal cables.
- Use a shielded twisted pair cable for connection with the encoder and for control signal transmission, and connect the external conductor of the cable to the SD terminal.
- Ground the servo amplifier, servo motor, etc. together at one point. (Refer to section 3.11.)

(b) Reduction techniques for external noises that cause the servo amplifier to malfunction

If there are noise sources (such as a magnetic contactor, an electromagnetic brake, and many relays which make a large amount of noise) near the servo amplifier and the servo amplifier may malfunction, the following countermeasures are required.

- Provide surge absorbers on the noise sources to suppress noises.
- Attach data line filters to the signal cables.
- Ground the shields of the encoder connecting cable and the control signal cables with cable clamp fittings.
- Although a surge absorber is built into the servo amplifier, to protect the servo amplifier and other equipment against large exogenous noise and lightning surge, attaching a varistor to the power input section of the equipment is recommended.

(c) Techniques for noises radiated by the servo amplifier that cause peripheral devices to malfunction

Noises produced by the servo amplifier are classified into those radiated from the cables connected to the servo amplifier and its main circuits (input and output circuits), those induced electromagnetically or statically by the signal cables of the peripheral devices located near the main circuit cables, and those transmitted through the power supply cables.

11. OPTIONS AND AUXILIARY EQUIPMENT

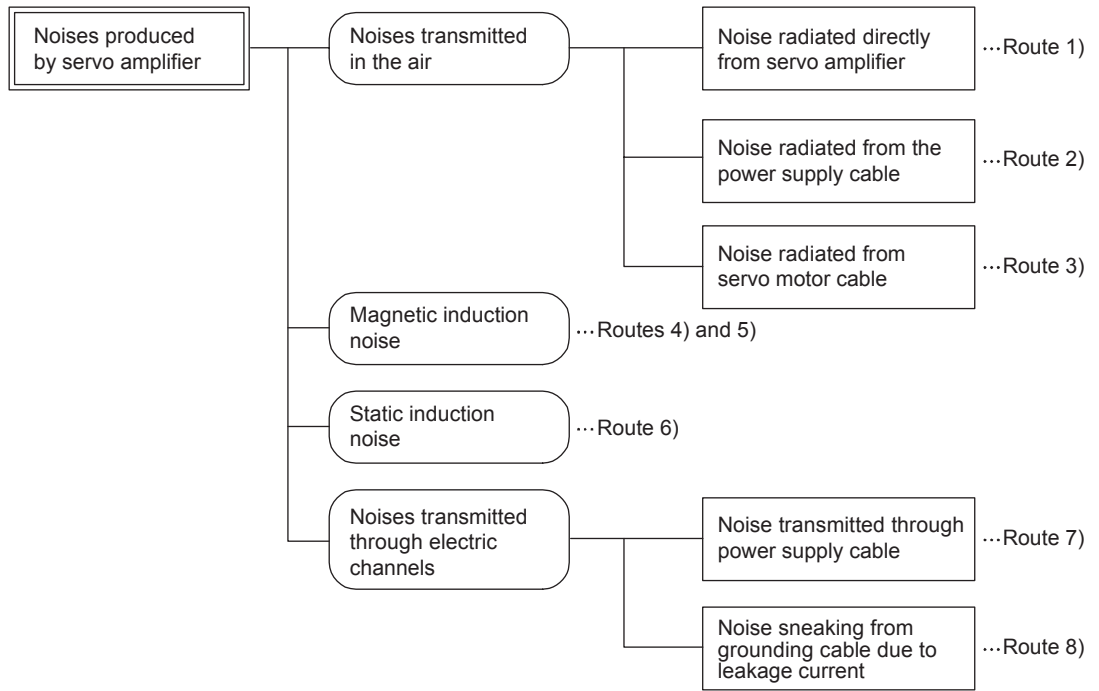

11. OPTIONS AND AUXILIARY EQUIPMENT

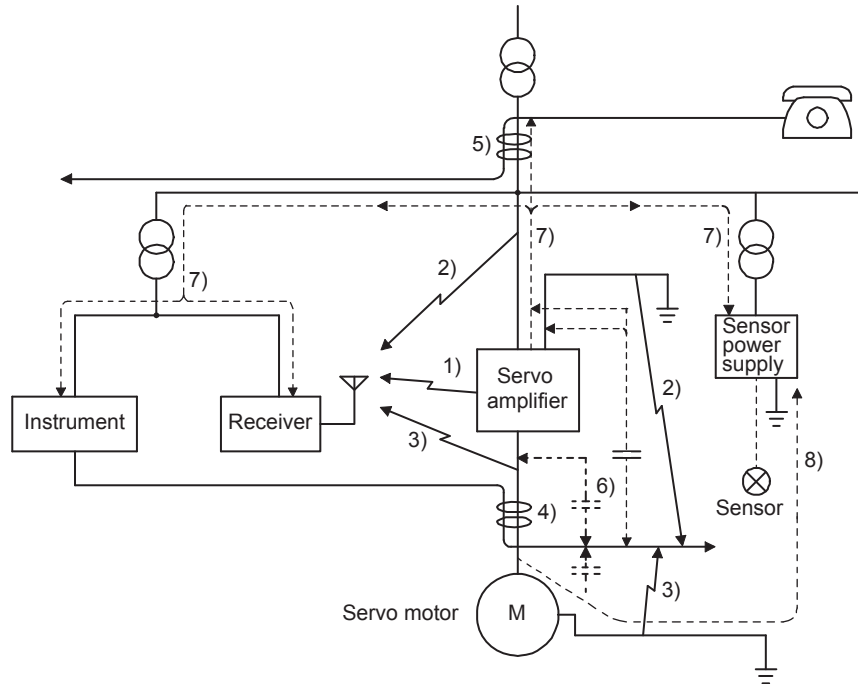

| Noise transmission route | Suppression techniques |
|--------------------------|---|
| 1) 2) 3) | <p>When measuring instruments, receivers, sensors, etc. which handle weak signals and may malfunction due to noise and/or their signal cables are contained in a cabinet together with the servo amplifier or run near the servo amplifier, such devices may malfunction due to noises transmitted through the air. The following techniques are required.</p> <ol style="list-style-type: none"> 1. Provide maximum clearance between easily affected devices and the servo amplifier. 2. Provide maximum clearance between easily affected signal cables and the I/O cables of the servo amplifier. 3. Avoid laying the power lines (Input cables of the servo amplifier) and signal cables side by side or bundling them together. 4. Insert a line noise filter to the I/O cables or a radio noise filter on the input line. 5. Use shielded wires for signal and power cables or put cables in separate metal conduits. |
| 4) 5) 6) | <p>When the power lines and the signal cables are laid side by side or bundled together, magnetic induction noise and static induction noise will be transmitted through the signal cables and malfunction may occur. The following techniques are required.</p> <ol style="list-style-type: none"> 1. Provide maximum clearance between easily affected devices and the servo amplifier. 2. Provide maximum clearance between easily affected signal cables and the I/O cables of the servo amplifier. 3. Avoid laying the power lines (Input cables of the servo amplifier) and signal cables side by side or bundling them together. 4. Use shielded wires for signal and power cables or put cables in separate metal conduits. |
| 7) | <p>When the power supply of peripheral devices is connected to the power supply of the servo amplifier system, noises produced by the servo amplifier may be transmitted back through the power supply cable and the devices may malfunction. The following techniques are required.</p> <ol style="list-style-type: none"> 1. Insert the radio noise filter (FR-BIF) on the power cables (Input cables) of the servo amplifier. Insert the line noise filter (FR-BSF01/FR-BLF) on the power cables of the servo amplifier. |
| 8) | <p>When the cables of peripheral devices are connected to the servo amplifier to make a closed loop circuit, leakage current may flow to malfunction the peripheral devices. If so, malfunction may be prevented by disconnecting the grounding cable of the peripheral device.</p> |

11. OPTIONS AND AUXILIARY EQUIPMENT

(2) Noise reduction techniques

(a) Data line filter (recommended)

Noise can be prevented by installing a data line filter onto the encoder cable, etc.

For example, ZCAT3035-1330 by TDK, ESD-SR-250 by NEC TOKIN, and GRFC-13 by Kitagawa Industries are available as data line filters.

As a reference example, the impedance specifications of the ZCAT3035-1330 (TDK) are indicated below. These impedances are reference values and not guaranteed values.

| Impedance [Ω] | |
|------------------------|------------------|
| 10MHz to 100MHz | 100MHz to 500MHz |
| 80 | 150 |

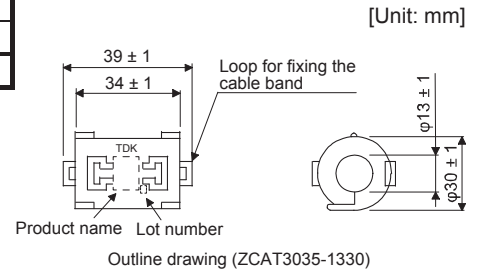

(b) Surge killer (recommended)

Use of a surge killer is recommended for AC relay, magnetic contactor or the like near the servo amplifier. Use the following surge killer or equivalent.

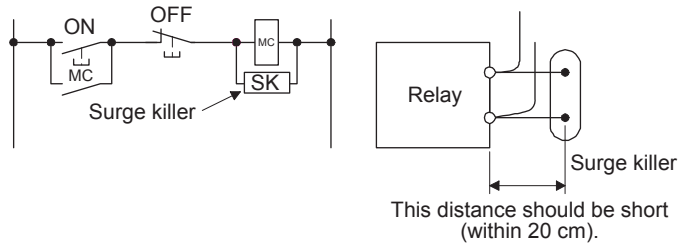

(Ex.) CR-50500 Okaya Electric Industries)

| Rated voltage Voltage AC [V] | C [$\mu\text{F} \pm 20\%$] | R [$\Omega \pm 30\%$] | Test voltage |
|------------------------------------|---------------------------------|----------------------------|---|
| 250 | 0.5 | 50 (1/2 W) | Between terminals: 625 V AC, 50/60 Hz 60 s Between terminal and case: 2000 V AC 50/60 Hz 60 s |

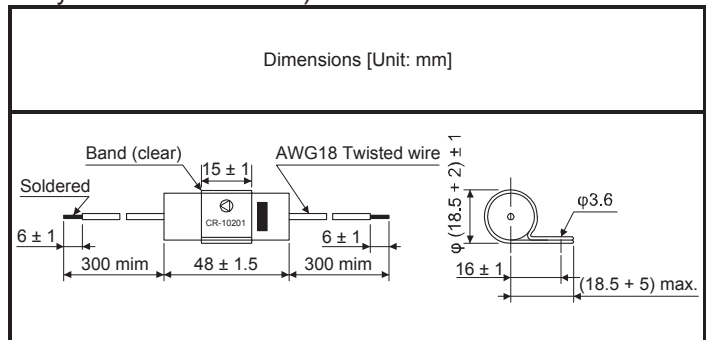

Note that a diode should be installed to a DC relay or the like.

Maximum voltage: Not less than 4 times the drive voltage of the relay or the like

Maximum current: Not less than twice the drive current of the relay or the like

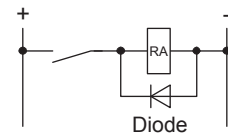

11. OPTIONS AND AUXILIARY EQUIPMENT

(c) Cable clamp fitting AERSBAN-_SET

Generally, the grounding of the shielded wire may only be connected to the connector's SD terminal. However, the effect can be increased by directly connecting the cable to an grounding plate as shown below.

Install the grounding plate near the servo amplifier for the encoder cable. Peel part of the cable sheath to expose the external conductor, and press that part against the grounding plate with the cable clamp. If the cable is thin, clamp several cables in a bunch.

The clamp comes as a set with the grounding plate.

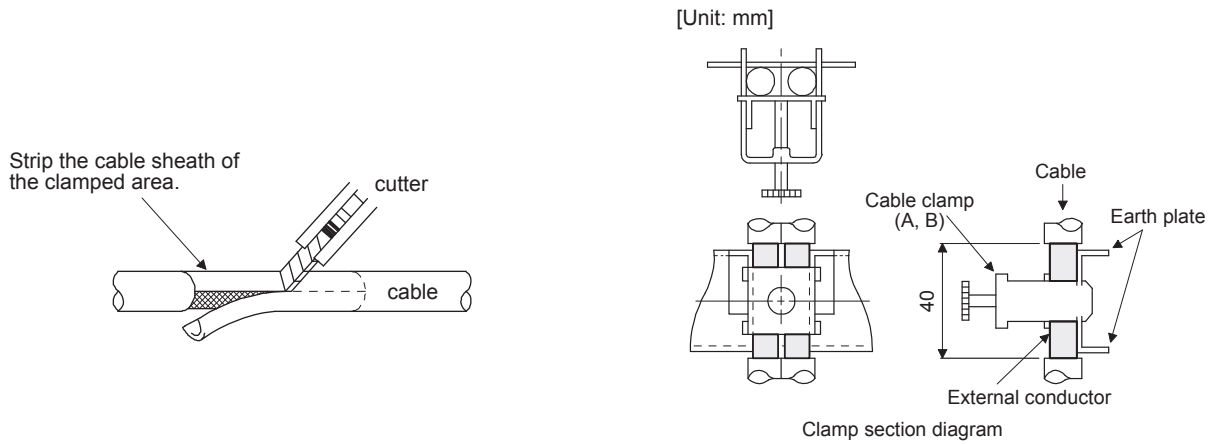

▪ Dimensions

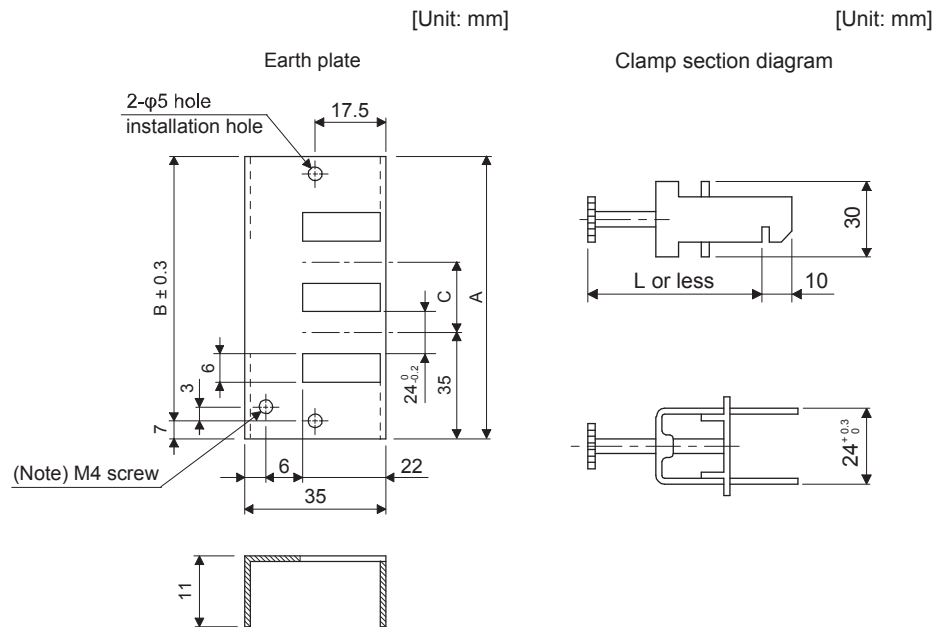

Note. Screw hole for grounding. Connect it to the grounding plate of the cabinet.

| Model | A | B | C | Accessory fittings |
|--------------|-----|----|----|--------------------|
| AERSBAN-DSET | 100 | 86 | 30 | Clamp A: 2 pcs. |
| AERSBAN-ESET | 70 | 56 | | Clamp B: 1 pc. |

| Clamp fitting | L |
|---------------|----|
| A | 70 |
| B | 45 |

11. OPTIONS AND AUXILIARY EQUIPMENT

(d) Line noise filter (FR-BSF01/ FR-BLF)

This filter is effective in suppressing noises radiated from the power supply side and output side of the servo amplifier and also in suppressing high-frequency leakage current (0-phase current). It especially affects the noises between 0.5 MHz and 5 MHz band.

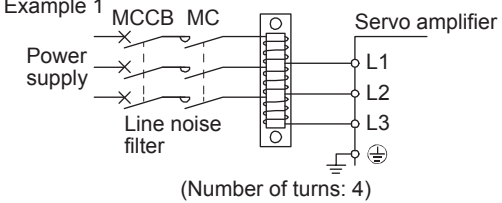
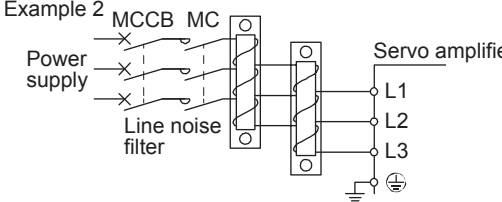
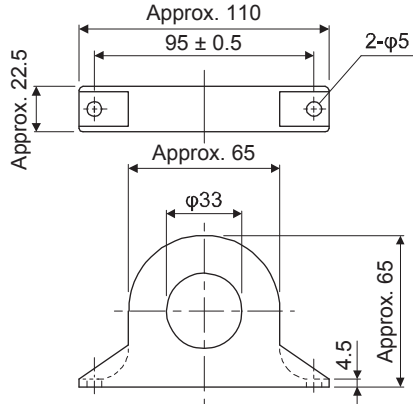
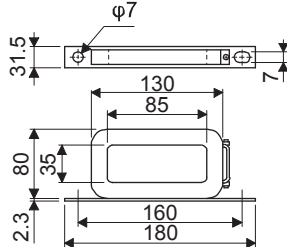
| Connection diagram | Dimensions [Unit: mm] |
|---|--|
| <p>Use the line noise filters for wires of the main power supply (L1, L2, and L3) and of the servo motor power (U, V, and W). Pass each of the wires through the line noise filter an equal number of times in the same direction. For the main power supply, the effect of the filter rises as the number of passes increases, but generally four passes would be appropriate. For the servo motor power lines, passes must be four times or less. Do not pass the grounding wire through the filter, or the effect of the filter will drop. Wind the wires by passing through the filter to satisfy the required number of passes as shown in Example 1. If the wires are too thick to wind, use two or more filters to have the required number of passes as shown in Example 2.</p> <p>Place the line noise filters as close to the servo amplifier as possible for their best performance.</p> <p>Example 1</p>  <p>(Number of turns: 4)</p> <p>Example 2</p>  <p>Two filters are used (Total number of turns: 4)</p> | <p>FR-BSF01 (for wire size 3.5 mm² (AWG 12) or less))</p>  <p>FR-BLF (for wire size 5.5 mm² (AWG 10) or more))</p>  |

11. OPTIONS AND AUXILIARY EQUIPMENT

(e) Radio noise filter (FR-BIF)

This filter is effective in suppressing noises radiated from the power supply side of the servo amplifier especially in 10 MHz and lower radio frequency bands. The FR-BIF is designed for the input only.

200 V class: FR-BIF

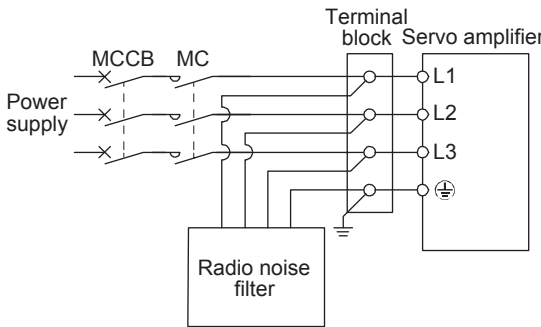
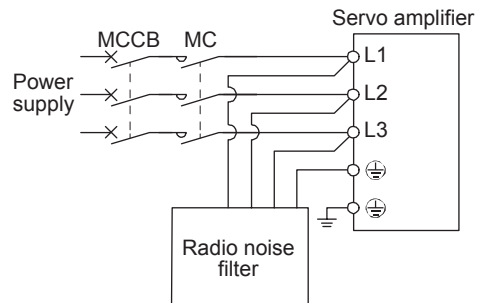
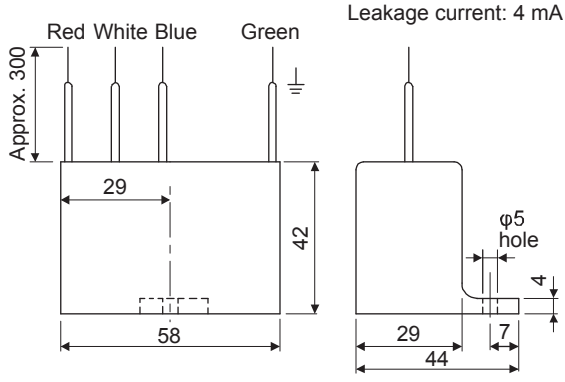
| Connection diagram | Dimensions [Unit: mm] |
|---|--|
| <p>Make the connection cables as short as possible. Grounding is always required.</p> <p>When using the FR-BIF with a single-phase power supply, always insulate the lead wires that are not used for wiring.</p> <p>MR-J4-350A or less</p>  <p>MR-J4-500A or more</p>  | <p>Dimensions [Unit: mm]</p> <p>Leakage current: 4 mA</p>  |

11. OPTIONS AND AUXILIARY EQUIPMENT

(f) Varistor for input power supply (recommended)

Varistors are effective to prevent exogenous noise and lightning surge from entering the servo amplifier. When using a varistor, connect it between each phase of the input power supply of the equipment. For varistors, the TND20V-431K and TND20V-471K, manufactured by NIPPON CHEMI-CON, are recommended. For detailed specification and usage of the varistors, refer to the manufacturer catalog.

| Power supply voltage | Varistor | Maximum rated | | | | | Maximum limit voltage | | Static capacity (reference value) | Varistor voltage rating (range) V1 mA |
|----------------------|-------------|-----------------------------|-------|------------------------|-----------------|-------------------|-----------------------|-----|-----------------------------------|---------------------------------------|
| | | Permissible circuit voltage | | Surge current immunity | Energy immunity | Rated pulse power | [A] | [V] | | |
| | | AC[Vrms] | DC[V] | 8/20 μ s [A] | 2 ms [J] | [W] | | | [pF] | [V] |
| 200 V class | TND20V-431K | 275 | 350 | 10000/1 time | 195 | 1.0 | 100 | 710 | 1300 | 430 (387 to 473) |
| | TND20V-471K | 300 | 385 | 7000/2 time | 215 | | | 775 | 1200 | 470 (423 to 517) |

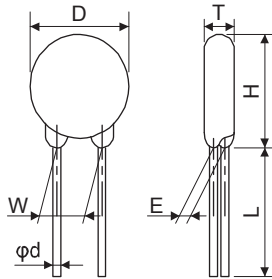

[Unit: mm]

| Model | D Max. | H Max. | T Max. | E \pm 1.0 | (Note) L min. | ϕ d \pm 0.05 or less | W 1.0 or less |
|-------------|--------|--------|--------|-------------|---------------|-----------------------------|---------------|
| TND20V-431K | 21.5 | 24.5 | 6.4 | 3.3 | 20 | 0.8 | 10.0 |
| TND20V-471K | | | 6.6 | 3.5 | | | |

Note. For special purpose items for lead length (L), contact the manufacturer.

11. OPTIONS AND AUXILIARY EQUIPMENT

11.15 Leakage current breaker

(1) Selection method

High-frequency chopper currents controlled by pulse width modulation flow in the AC servo circuits. Leakage currents containing harmonic contents are larger than those of the motor which is run with a commercial power supply.

Select a leakage current breaker according to the following formula, and ground the servo amplifier, servo motor, etc. securely.

To minimize leakage currents, make the input and output cables as short as possible, and make the grounding cable longer than 30 cm.

$$\text{Rated sensitivity current} \geq 10 \cdot \{I_{g1} + I_{gn} + I_{ga} + K \cdot (I_{g2} + I_{gm})\} \text{ [mA]} \dots \dots \dots (11.1)$$

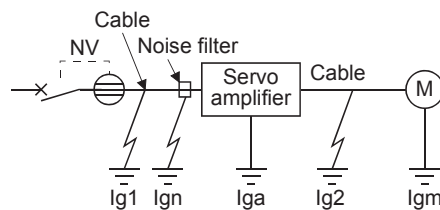

| Leakage current breaker | | K |
|--|---------------------|---|
| Type | Mitsubishi products | |
| Models provided with harmonic and surge reduction techniques | NV-SP | 1 |
| | NV-SW | |
| | NV-CP | |
| | NV-CW | |
| | NV-HW | |
| General models | BV-C1 | 3 |
| | NFB | |
| | NV-L | |

I_{g1} : Leakage current on the electric channel from the leakage current breaker to the input terminals of Ig₂ the servo amplifier (Found from Fig. 11.5.)

I_{gn} : Leakage current on the electric channel from the output terminals of the servo amplifier to the I_{ga} servo motor (Found from Fig. 11.5.)

I_{gm} : Leakage current when a filter is connected to the input side (4.4 mA per one FR-BIF)

: Leakage current of the servo amplifier (Found from table 11.4.)

: Leakage current of the servo motor (Found from table 11.3.)

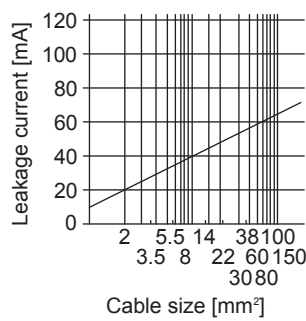

Fig. 11.5 Leakage current example (I_{g1}, I_{g2}) for CV cable run in metal conduit

11. OPTIONS AND AUXILIARY EQUIPMENT

Table 11.3 Servo motor's leakage current example (Igm)

| Servo motor power [kW] | Leakage current [mA] |
|------------------------|----------------------|
| 0.05 to 1 | 0.1 |
| 2 | 0.2 |
| 3.5 | 0.3 |
| 5 | 0.5 |
| 7 | 0.7 |

Table 11.4 Servo amplifier's leakage current example (Iga)

| Servo amplifier capacity [kW] | Leakage current [mA] |
|-------------------------------|----------------------|
| 0.1 to 0.6 | 0.1 |
| 0.75 to 3.5 | 0.15 |
| 5/7 | 2 |

Table 11.5 Leakage circuit breaker selection example

| Servo amplifier capacity [kW] | Rated sensitivity current of leakage circuit breaker [mA] |
|-------------------------------|---|
| MR-J4-10A to MR-J4-70A | 15 |
| MR-J4-500A | 30 |
| MR-J4-700A | 50 |

11. OPTIONS AND AUXILIARY EQUIPMENT

(2) Selection example

Indicated below is an example of selecting a leakage current breaker under the following conditions.

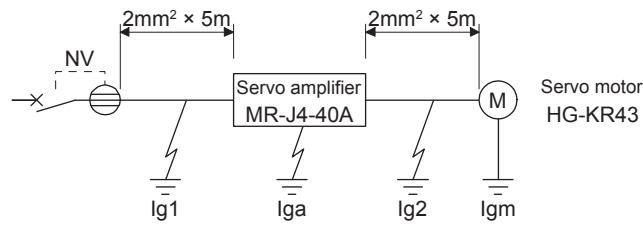

Use a leakage current breaker designed for suppressing harmonics/surges.
Find the terms of equation (11.1) from the diagram.

$$I_{g1} = 20 \cdot \frac{5}{1000} = 0.1 \text{ [mA]}$$

$$I_{g2} = 20 \cdot \frac{5}{1000} = 0.1 \text{ [mA]}$$

$$I_{gn} = 0 \text{ (not used)}$$

$$I_{ga} = 0.1 \text{ [mA]}$$

$$I_{gm} = 0.1 \text{ [mA]}$$

Insert these values in equation (11.1).

$$I_g \geq 10 \cdot \{10 + 0 + 0.1 + 1 \cdot (0.1 + 0.1)\} \\ \geq 4 \text{ [mA]}$$

According to the result of calculation, use a leakage current breaker having the rated sensitivity current (I_g) of 4.0 [mA] or more.

A leakage current breaker having I_g of 15 [mA] is used with the NV-SP/SW/CP/CW/HW series.

11. OPTIONS AND AUXILIARY EQUIPMENT

11.16 EMC filter (recommended)

It is recommended that one of the following filters be used to comply with EN standard's EMC directive. Some EMC filters have large in leakage current.

(1) Combination with the servo amplifier

| Servo amplifier | Recommended filter (Soshin Electric) | | | Mass [kg] |
|-------------------------|--------------------------------------|-------------------|---|-----------|
| | Model | Rated current [A] | Rated voltage [VAC: Leakage current [mA] | |
| MR-J4-10A to MR-J4-100A | (Note) HF3010A-UN | 10 | Max. 250 | 3.5 |
| MR-J4-200A, MR-J4-350A | (Note) HF3010A-UN | 30 | | 5 |
| MR-J4-500A, MR-J4-700A | (Note) HF3010A-UN | 40 | | 6.5 |

Note. A surge protector is separately required to use any of these EMC filters.

(2) Connection example

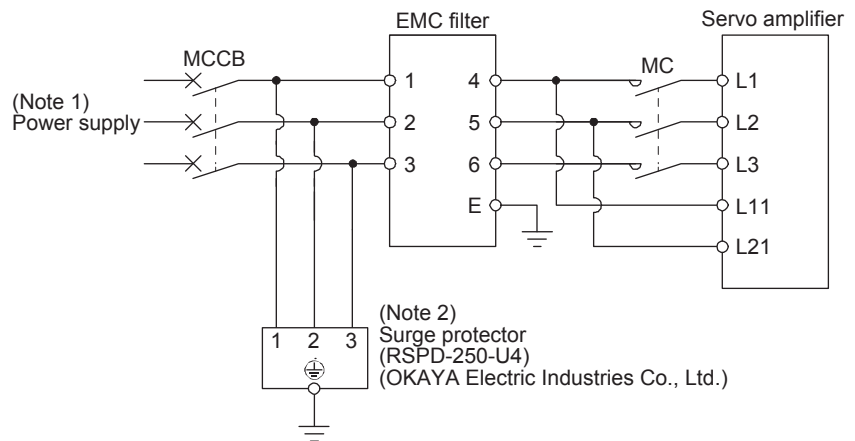

- Note 1. For 1-phase 200 V AC to 240 V AC, connect the power supply to L1 and L3. Leave L2 open.
- Note 2. The example is when a surge protector is connected.

11. OPTIONS AND AUXILIARY EQUIPMENT

- (3) Dimensions
 - (a) EMC filter
 - HF3010A-UN

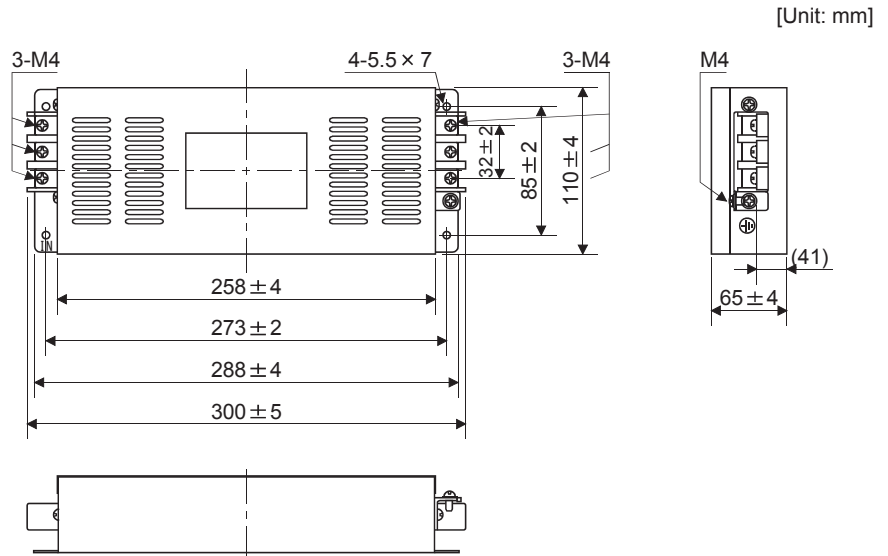

HF3030A-UN/HF-3040A-UN

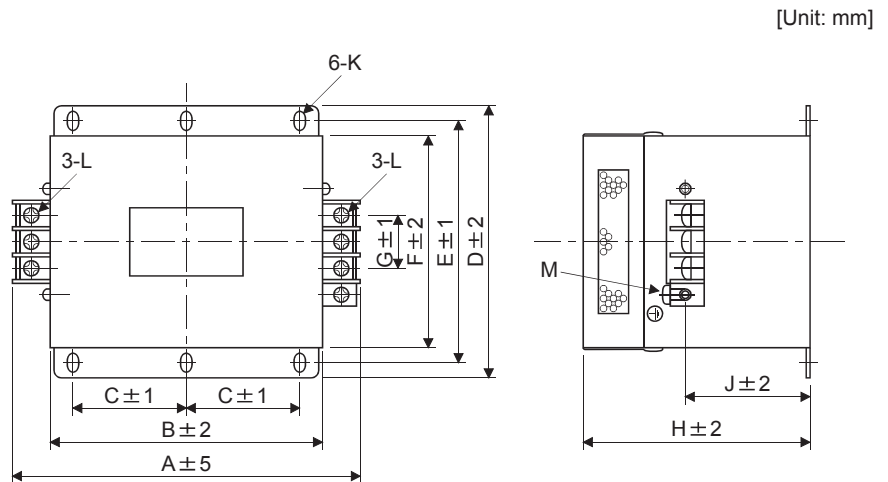

| Model | Dimensions [mm] | | | | | | | | | | | |
|------------|-----------------|-----|----|-----|-----|-----|----|-----|----|--------------------|----|----|
| | A | B | C | D | E | F | G | H | J | K | L | M |
| HF3030A-UN | 260 | 210 | 85 | 155 | 140 | 125 | 44 | 140 | 70 | R3.25 length: 8 | M5 | M4 |
| HF3040A-UN | | | | | | | | | | | | |

11. OPTIONS AND AUXILIARY EQUIPMENT

(b) Surge protector

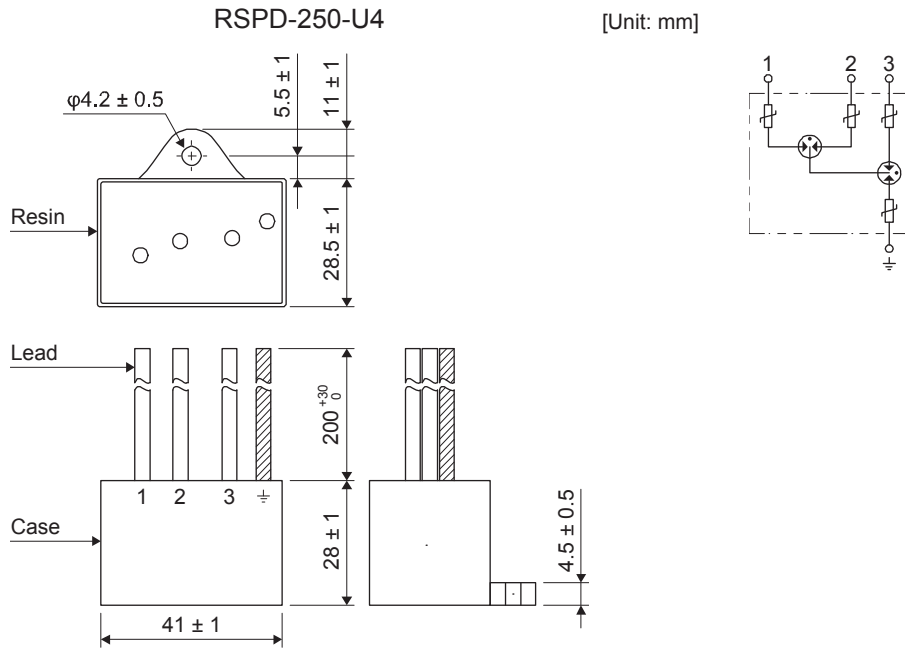

12. ABSOLUTE POSITION DETECTION SYSTEM

12. ABSOLUTE POSITION DETECTION SYSTEM



CAUTION

- If [AL. 25 Absolute position erased] or [AL. E3 Absolute position counter warning] has occurred, always perform home position setting again. Otherwise, it may cause an unexpected operation.
- Refer to appendix 2 and 3 for battery transportation and the new EU Battery Directive.
- If [AL. 25], [AL. 92], or [AL. 9F] occur due to such as short circuit of the battery, the MR-BAT6V1 battery can become hot. Use the MR-BAT6V1 battery with care to prevent getting burnt.

POINT

- Disconnecting the encoder cable will erase the absolute position data. After disconnecting the encoder cable, always execute home position setting and then positioning operation.

12.1 Summary

12.1.1 Features

For normal operation, as shown below, the encoder consists of a detector designed to detect a position within one revolution and a cumulative revolution counter designed to detect the number of revolutions. The absolute position detection system always detects the absolute position of the machine and keeps it battery-backed, independently of whether the programming controller power is on or off. Therefore, once home position return is made at the time of machine installation, home position return is not needed when power is switched on thereafter.

Even at a power failure or a malfunction, the system can be easily restored.

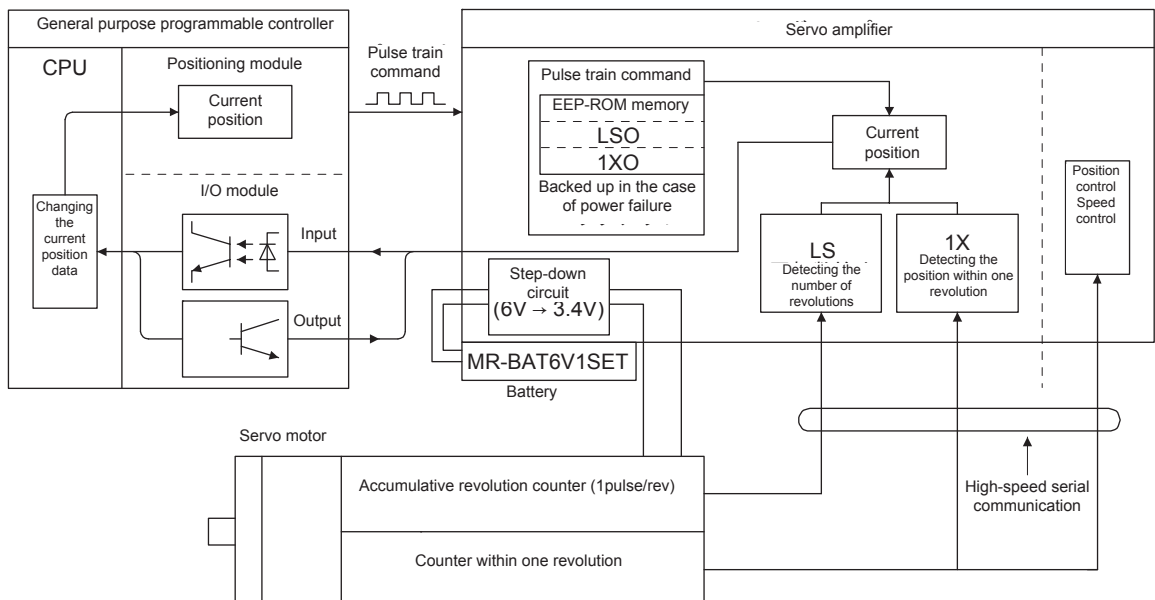

12. ABSOLUTE POSITION DETECTION SYSTEM

12.1.2 Restrictions

The absolute position detection system cannot be configured under the following conditions. Test operation cannot be performed in the absolute position detection system, either. To perform test operation, choose incremental system in [Pr. PA03].

- (1) Speed control mode and torque control mode.
- (2) Control switch-over mode (position/speed, speed/torque, and torque/position).
- (3) Stroke-less coordinate system, e.g. rotary shaft, infinitely long positioning.
- (4) Changing of electronic gear after home position setting.
- (5) Use of alarm code output.

12.2 Specifications

(1) Specification list

| Item | | Description |
|--|---|---|
| System | | Electronic battery backup type |
| Battery | Model | MR-BAT6V1SET |
| | Battery pack | 2CR17335A (Primary lithium battery) |
| | Nominal voltage [V] | 6 |
| | Nominal capacity [mAh] | 1650 |
| | Operating temperature [°C] | 0 to 55 |
| | Operating temperature [°C] | 0 to 55 |
| | Amount of lithium metal [g] | 1.2 |
| | Mercury content | Less than 1 ppm |
| | Dangerous goods class | Inapplicable to Class 9 (Battery pack containing 2 g or less lithium) |
| | Operating humidity and storage humidity | 90% RH or less (non-condensing) |
| Mass [g] | 34 | |
| Maximum revolution range | | Home position ± 32767 rev. |
| (Note 1) Maximum speed at power failure [r/min] | Rotary servo motor | 6000 (However, it is only when the acceleration time up to 6000 r/min is 0.2 s or longer.) |
| (Note 2) Battery backup time | Rotary servo motor | Approximately 20,000 hours (equipment power supply: off, ambient temperature: 20 °C) |
| (Note 3) Battery life | | 5 years from date of manufacture |

- Note 1. Maximum speed available when the shaft is rotated by external force at the time of power failure or the like.
2. The data-holding time using a battery of MR-BAT6V1SET on condition that the power supply of the servo amplifier is off. Replace the batteries within 3 years since the operation start whether the power supply of the servo amplifier is on/off. If the battery is used out of specification, [AL. 25 absolute position lost] may occur.
 3. Quality of the batteries degrades by the storage condition. The battery life is 5 years from the production date regardless of the connection status.

12. ABSOLUTE POSITION DETECTION SYSTEM

(2) Configuration

| Positioning module | I/O module |
|--|--|
| QD70P_ , QD70D_ | |
| QD75P_N, QD75D_N | QX40, QX41, QX42 QY40, QY41, QY42, QY50 |
| LD75P4, LD75D4 | LY40NT5P, LY41NT1P, LY42NT1P LY40PT5P, LY41PT1P, LY42PT1P |
| FX _{2N} _GM, FX _{2N} _PG | FX _{2N} series, FX _{0N} series |

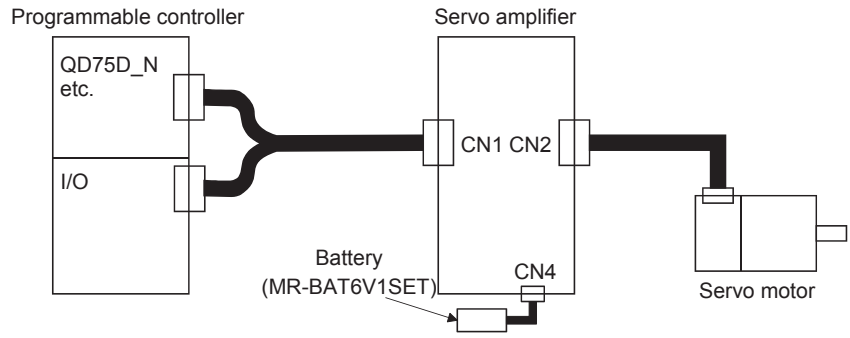

12. ABSOLUTE POSITION DETECTION SYSTEM

(3) Parameter setting

Set "___ 1" in [Pr.PA03] to make the absolute position detection system valid. Set "___ 2" when using the communication-based ABS transfer system. Refer to section 12.10 for the communication-based ABS transfer system.

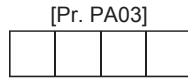

- └ Absolute position detection system selection
0: Used in incremental system
1: Used in absolute position detection system
 ABS transfer by DI0
2: Used in absolute position detection system (available in the future)
 ABS transfer by communication

12.3 Battery replacement procedure



WARNING

- Before installing a battery, turn off the main circuit power and wait for 15 minutes or longer until the charge lamp turns off. Then, check the voltage between P+ and N- with a voltage tester or others. Otherwise, an electric shock may occur. In addition, when confirming whether the charge lamp is off or not, always confirm it from the front of the servo amplifier.



CAUTION

- The internal circuits of the servo amplifier may be damaged by static electricity. Always take the following precautions.
 - Ground human body and work bench.
 - Do not touch the conductive areas, such as connector pins and electrical parts, directly by hand.

POINT

- Replacing battery with the control circuit power off will erase the absolute position data.

Replace the battery with only the control circuit power on. Replacing battery with the control circuit power on will not erase the absolute position data.

Refer to section 12.4 for installation procedure of battery to the servo amplifier.

12. ABSOLUTE POSITION DETECTION SYSTEM

12.4 Battery installation and removal procedure

(1) Installation procedure

POINT

- For the servo amplifier with a battery holder on the bottom, it is not possible to wire for the earth with the battery installed. Insert the battery after executing the earth wiring of the servo amplifier.

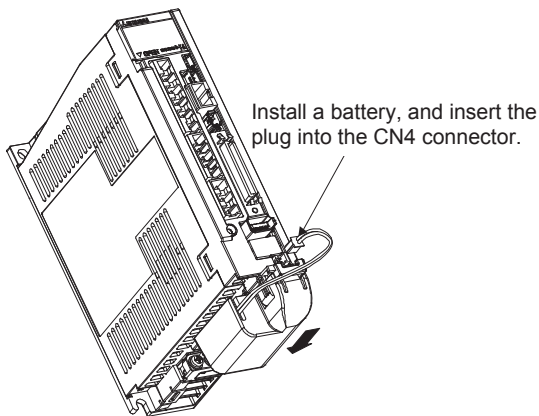

MR-J4-350A or smaller capacity models

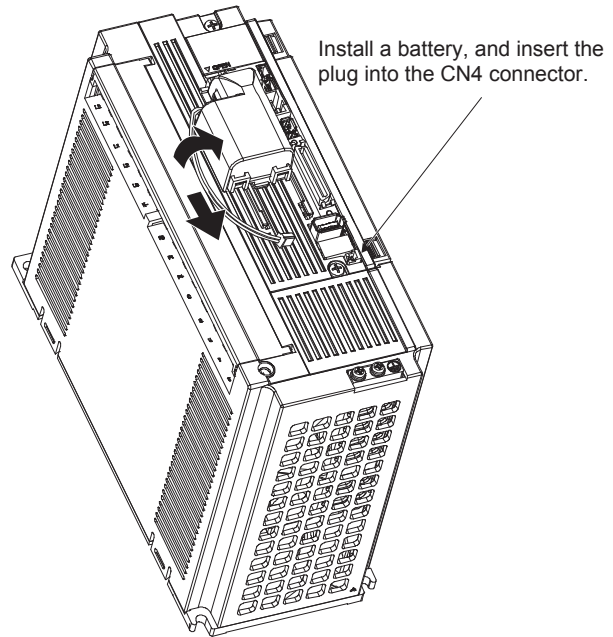

MR-J4-500A or larger capacity models

(2) Removal procedure



CAUTION

- Pulling out the connector of the MR-BAT6V1SET without the lock release lever pressed may damage the CN4 connector of the servo amplifier or the connector of the MR-BAT6V1SET.

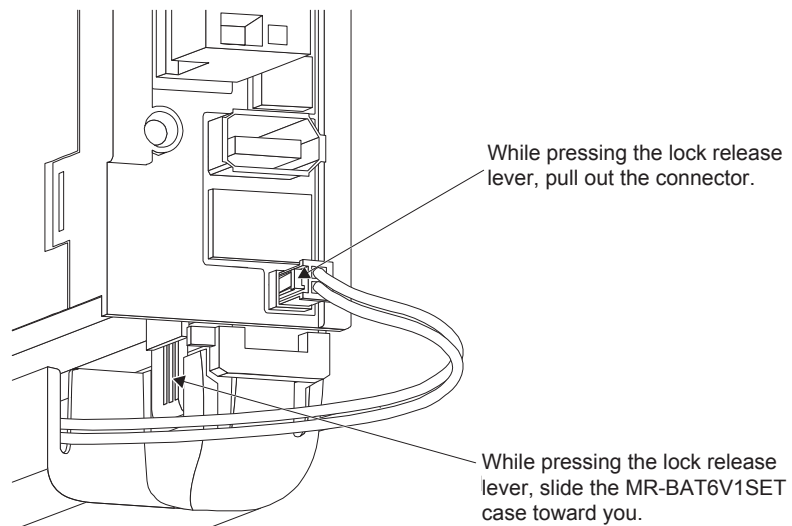

12. ABSOLUTE POSITION DETECTION SYSTEM

(3) Replacement procedure of the battery in the MR-BAT6V1SET

When the MR-BAT6V1SET reaches the end of its life, replace the MR-BAT6V1 battery in the MR-BAT6V1SET.

While pressing the locking part, open the cover.

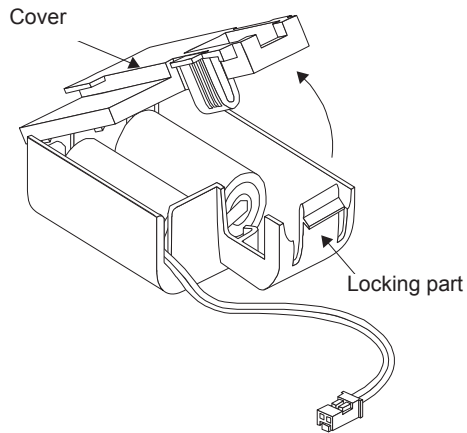

Replace the battery with a new MR-BAT6V1 battery.

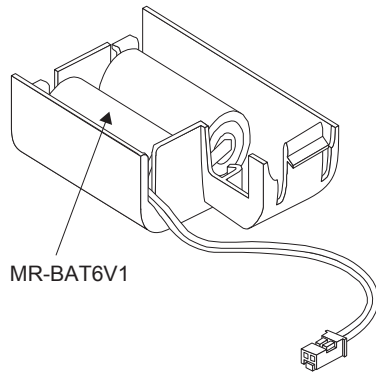

Press the cover until it is fixed with the projection of the locking part to close the cover.

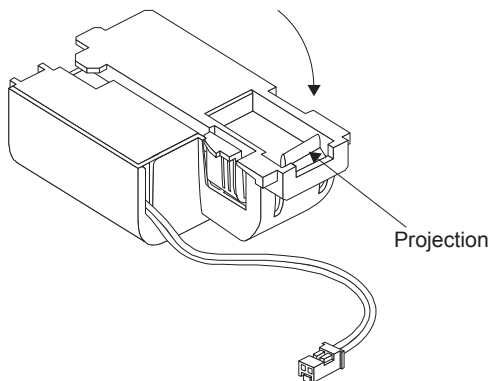

12. ABSOLUTE POSITION DETECTION SYSTEM

12.5 Standard connection example

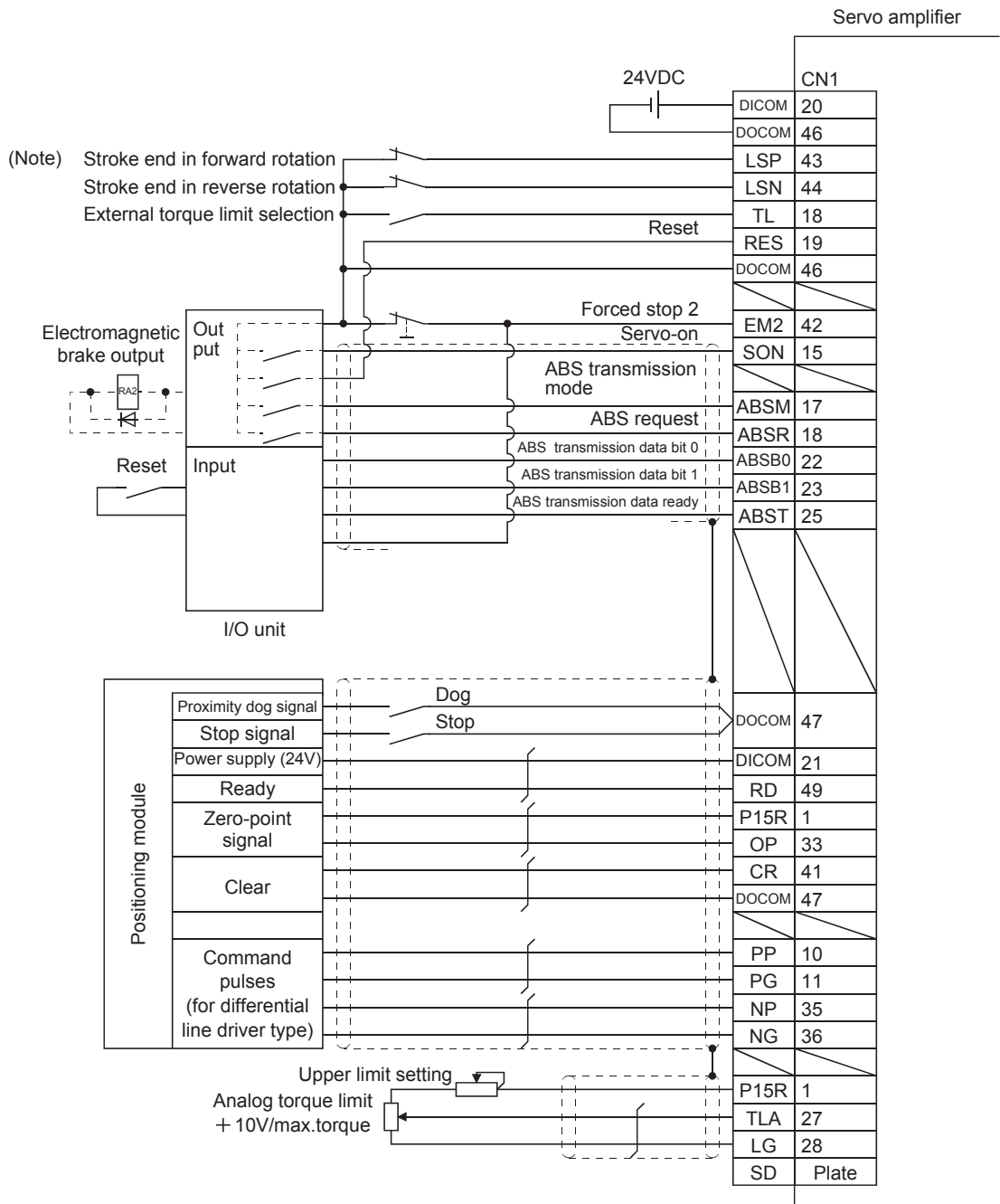

Note. For operation, always turn on LSP and LSN.

12. ABSOLUTE POSITION DETECTION SYSTEM

12.6 Signal explanation

When the absolute position data is transferred, the signals of connector CN1 change as described in this section. They return to the previous status on completion of data transfer. The other signals are as described in section 3.5.

For the I/O interfaces (symbols in the I/O Category column in the table), refer to section 3.9.2.

| Signal name | Code | CN1 Pin No. | Function/Application | I/O category | Control mode |
|-----------------------------|-------|-------------|--|--------------|-------------------------|
| ABS transfer mode | ABSM | (Note) 17 | While ABSM is on, the servo amplifier is in the ABS transfer mode, and the functions of CN1-22, CN1-23, and CN1-25 are as indicated in this table. | DI-1 | P (Position control) |
| ABS request | ABSR | (Note) 18 | Turn on ABSR to request the ABS data in the ABS transfer mode. | DI-1 | |
| ABS transmission data bit 0 | ABSB0 | 22 | Indicates the lower bit of the ABS data (2 bits) which is sent from the servo to the programmable controller in the ABS transfer mode. If there is a signal, D01 turns on. | DO-1 | |
| ABS transmission data bit 1 | ABSB1 | 23 | Indicates the upper bit of the ABS data (2 bits) which is sent from the servo to the programmable controller in the ABS transfer mode. | DO-1 | |
| ABS transmission data ready | ABST | 25 | Indicates that the data to be sent is being prepared in the ABS transfer mode. At the completion of the ready state, ABST turns on. | DO-1 | |
| Home position setting | CR | 41 | When CR is turned on, the position control counter is cleared and the home position data is stored into the non-volatile memory (backup memory). | DI-1 | |

Note. When "Used in absolute position detection system" is selected in [Pr. PA03], pin 17 acts as ABSM and pin 18 as ABSR. They do not return to the original signals if data transfer ends.

12. ABSOLUTE POSITION DETECTION SYSTEM

12.7 Startup procedure

- (1) Battery installation.
Refer to section 12.4.
- (2) Parameter setting
Set " _ _ _ 1" in [Pr. PA03] of the servo amplifier and switch power off, then on.
- (3) Resetting of [AL. 25 Absolute position erased]
After connecting the encoder cable, [AL. 25] occurs at first power-on. Leave the alarm as it is for a few minutes, then switch power off, then on to reset the alarm.
- (4) Confirmation of absolute position data transfer
When SON is turned on, the absolute position data is transferred to the programmable controller. When the ABS data is transferred properly.
 - (a) RD (Ready) turns on.
 - (b) The programmable controller/ABS data ready contact turns on.
 - (c) The MR Configurator2 ABS data display window (refer to section 12.11) and programmable controller side ABS data registers show the same value (at the home position address of 0).
If any warning such as [AL. E5 ABS time-out warning] or programmable controller side transfer error occurs, refer to section 12.9 or chapter 8 and take corrective action.
- (5) Home position setting
The home position must be set if.
 - (a) System set-up is performed;
 - (b) The servo amplifier has been changed;
 - (c) The servo motor has been changed; or
 - (d) [AL. 25 Absolute position erased] occurred.

In the absolute position detection system, the absolute position coordinates are made up by making home position setting at the time of system set-up. The motor shaft may operate unexpectedly if positioning operation is performed without home position setting.

Always make home position setting before starting.

For the home position setting method and types, refer to section 12.8.3.

12. ABSOLUTE POSITION DETECTION SYSTEM

12.8 Absolute position data transfer protocol

POINT

● After switching on ABSM, turn on SON. When the ABS transfer mode is off, turning on SON does not switch on the base circuit.

12.8.1 Data transfer procedure

Each time SON is turned on (when the power is switched on for example), the programmable controller reads the position data (present position) of the servo amplifier.

Time-out monitoring is performed by the programmable controller.

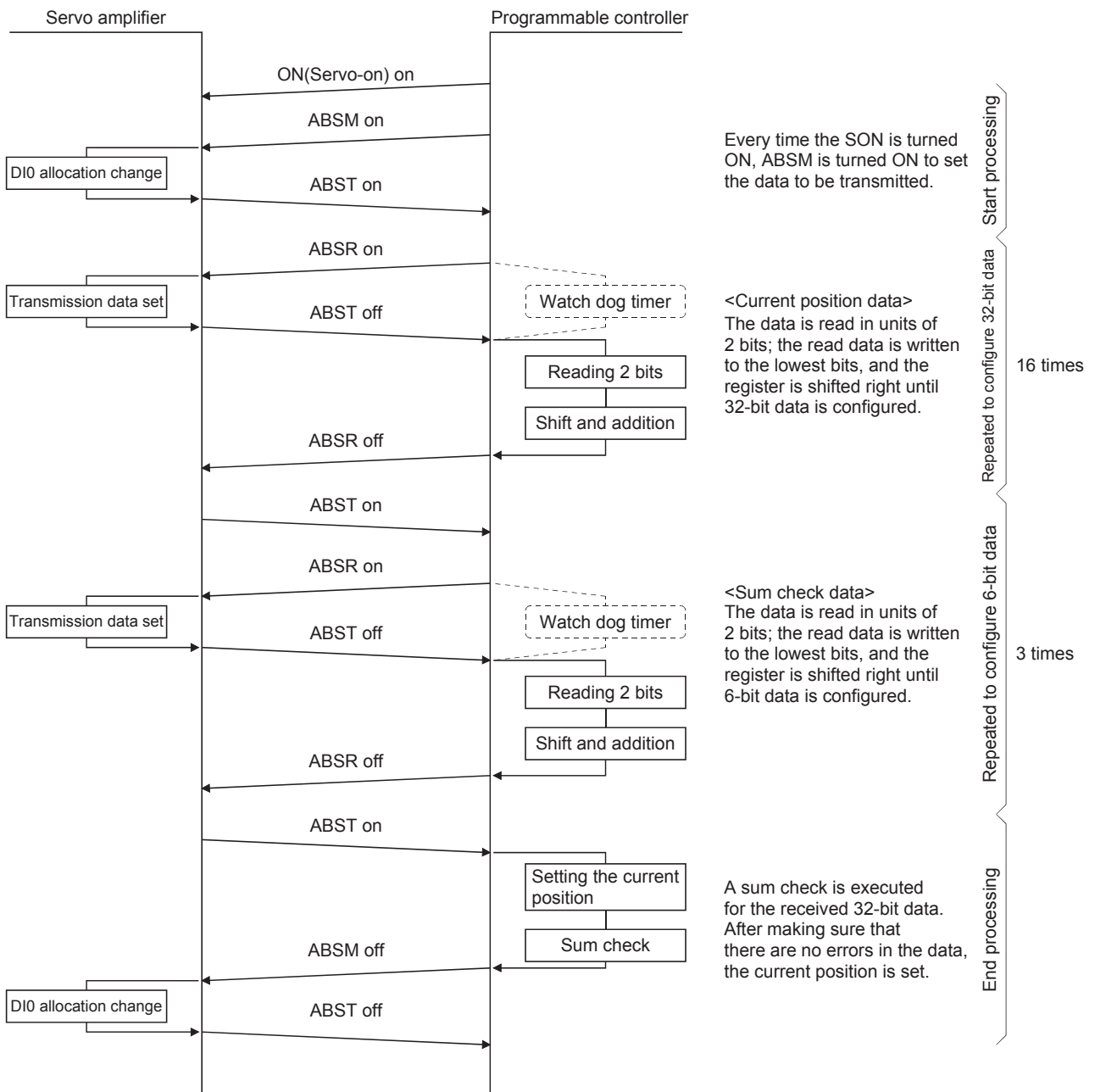

12. ABSOLUTE POSITION DETECTION SYSTEM

12.8.2 Transfer method

The following shows a sequence how to turn on the base circuit while it is off state because SON is off, EM2 is off, or an alarm is occurring. In the absolute position detection system, every time SON is turned on, ABSM should always be turned on to read the current position in the servo amplifier to the controller. The servo amplifier transmits to the controller the current position latched when ABSM switches from off to on. At the same time, this data is set as a position command value inside the servo amplifier. Unless ABSM (ABS transfer mode) is turned on, the base circuit cannot be turned on.

- (1) At power-on
 (a) Timing chart

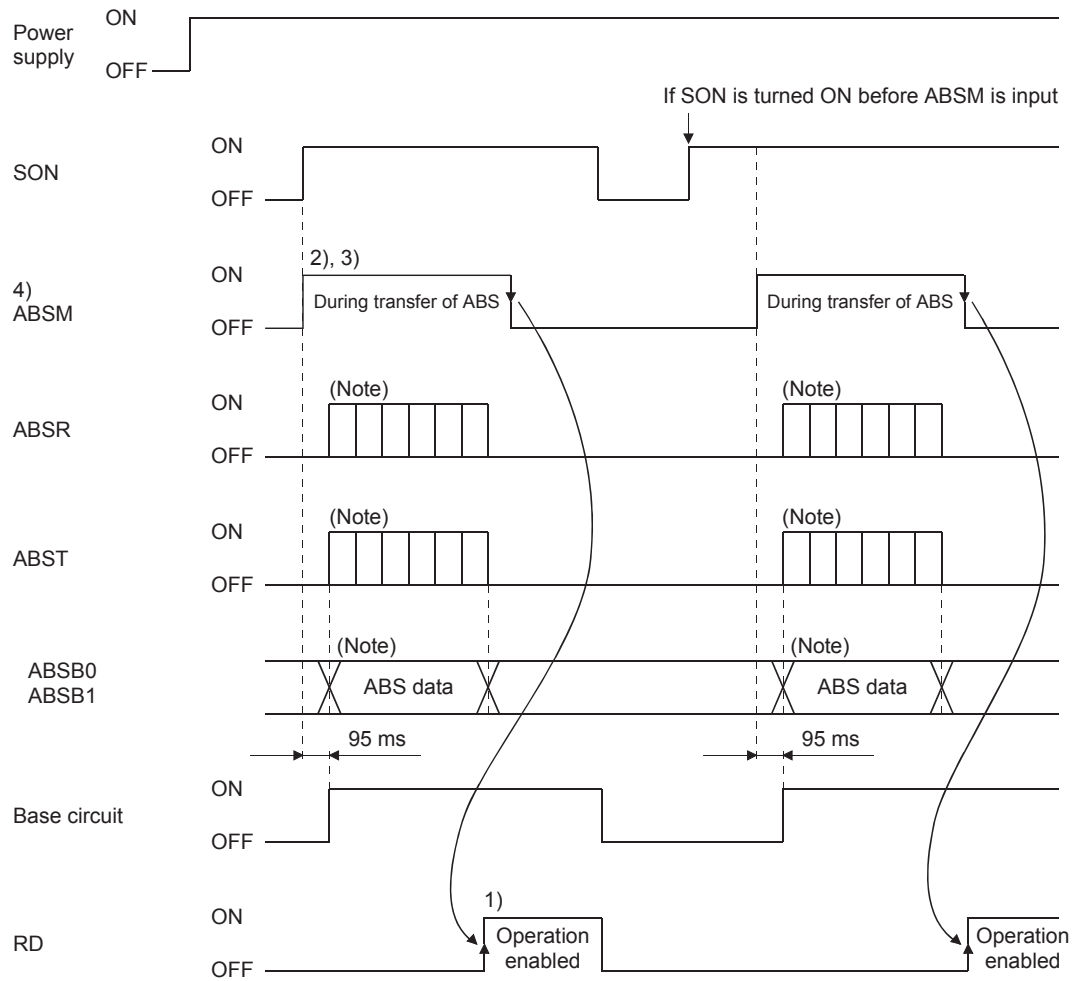

Note. For details, refer to (1) (b) of this section.

12. ABSOLUTE POSITION DETECTION SYSTEM

- 1) After the ABS data is transmitted, RD turns on by ABSM-off. When RD is on, ABSM-on is not received.
- 2) Even if SON is turned on before ABSM is turned on, the base circuit is not turned on until ABSM is turned on.
If a servo alarm has occurred, ABSM is not received. ABSM allows data transmission even while a servo warning is occurring.
- 3) If ABSM is turned off during the ABS transfer mode, the ABS transfer mode is interrupted and [AL. E5 ABS time-out warning] occurs.
If SON is turned off, RES is turned on, and EM2 is turned off during the ABS transfer mode, [AL. E5 ABS time-out warning] occurs.
- 4) Note that if ABSM is turned on for a purpose other than ABS data transmission, the output signals will be assigned the functions of ABS data transmission.

| CN1 Pin No. | Output signal | |
|-------------|------------------------------|------------------------------|
| | ABSM(ABS transfer mode): off | ABSM (ABS transfer mode): on |
| 22 | Positioning completion | transmission data bit 03 |
| 23 | Zero speed detection | transmission data bit 1 |
| 25 | During torque limit control | transmission data ready |

- 5) ABSM is not accepted while the base circuit is on. For re-transferring, turn off SON signal and keep the base circuit in the off state for 20 ms or longer.

(b) Detailed description of absolute position data transfer

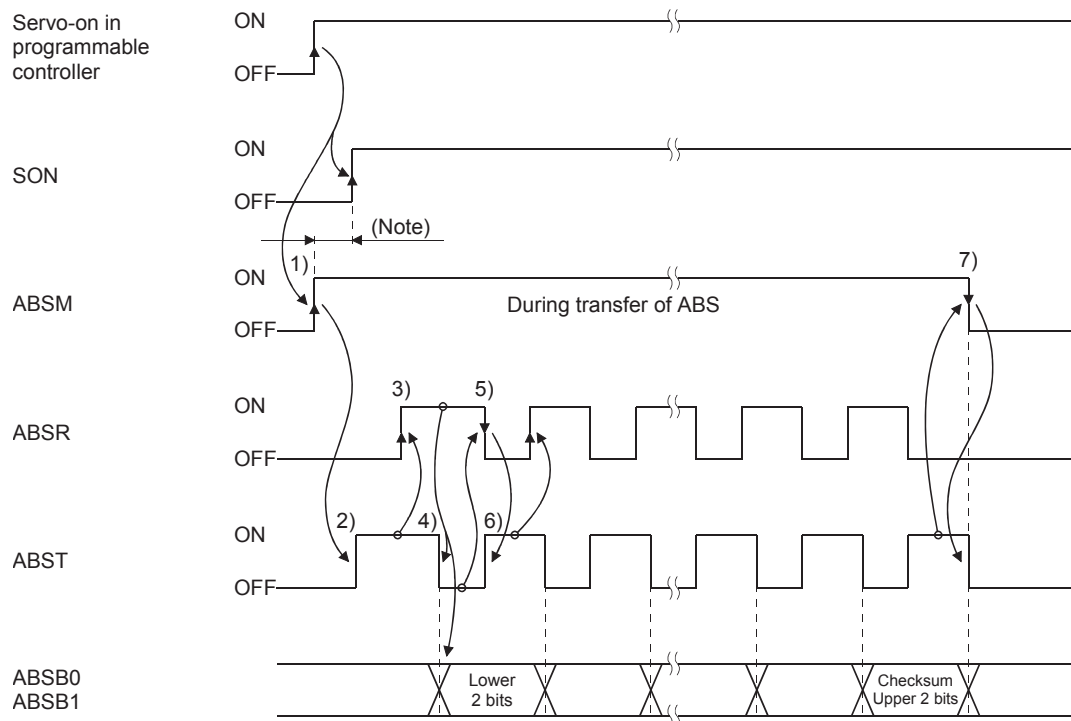

Note. If SON does not turn on within 1 s after ABSM off, [AL. EA ABS servo-on warning] will occur. But it will not influence the transfer. SON on will cancel [AL. EA] automatically.

12. ABSOLUTE POSITION DETECTION SYSTEM

(2) Transmission error

(a) [AL. E5 ABS time-out warning]

In the ABS transfer mode, the servo amplifier processes time-out below, and displays [AL. E5] when a time-out error occurs.

[AL. E5] is cleared when ABSM changes from off to on.

1) ABS request off-time time-out check (applied to 32-bit ABS data in 2-bit units checksum)

If the ABSR signal is not turned on by the programmable controller within 5 s after ABST is turned on, this is regarded as a transmission error and [AL. E5 ABS time-out warning] is output.

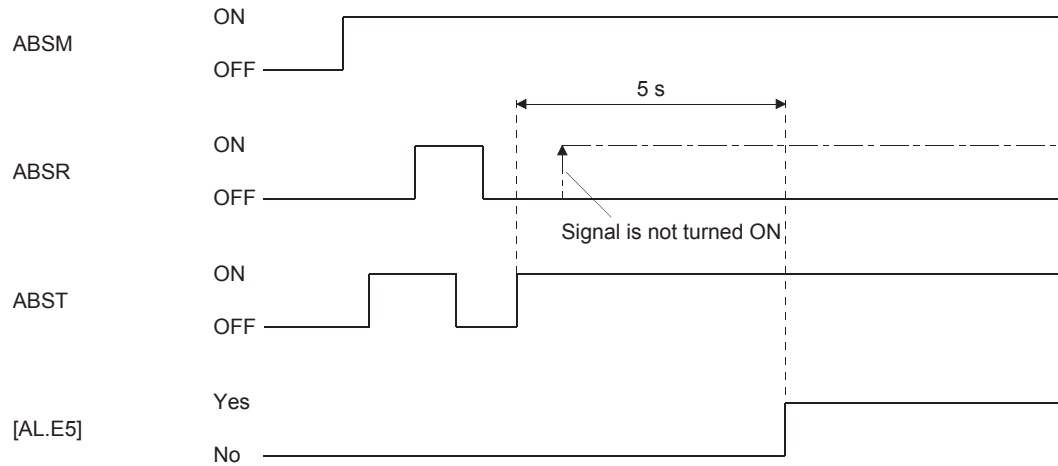

2) ABS request on-time time-out check (applied to 32-bit ABS data in 2-bit units checksum)

If the ABSR is not turned off by the programmable controller within 5 s after ABST is turned off, this is regarded as the transmission error and [AL. E5 ABS time-out warning] is output.

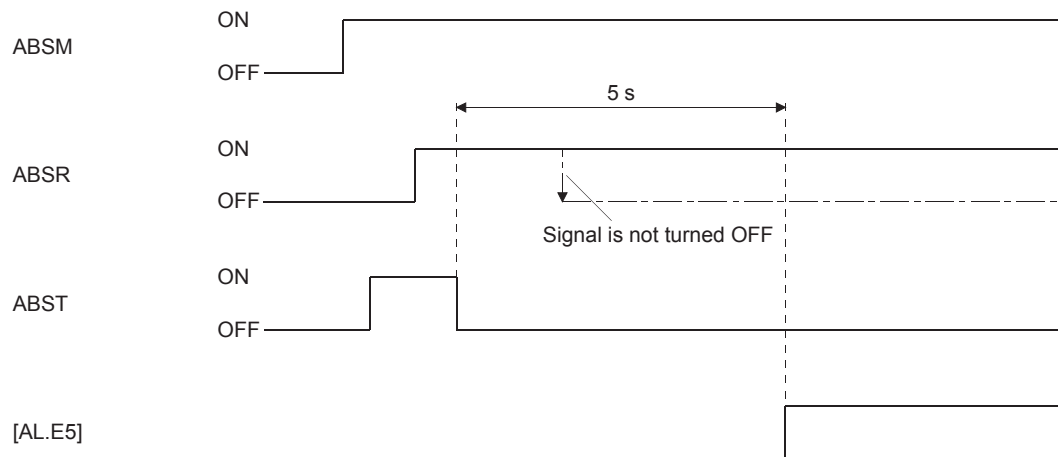

12. ABSOLUTE POSITION DETECTION SYSTEM

3) ABS transfer mode finish-time time-out check

If ABSM is not turned off within 5 s after the last ABS transmission data ready (19th signal for ABS data transmission) is turned on, it is regarded as the transmission error and the [AL. E5 ABS time-out warning] is output.

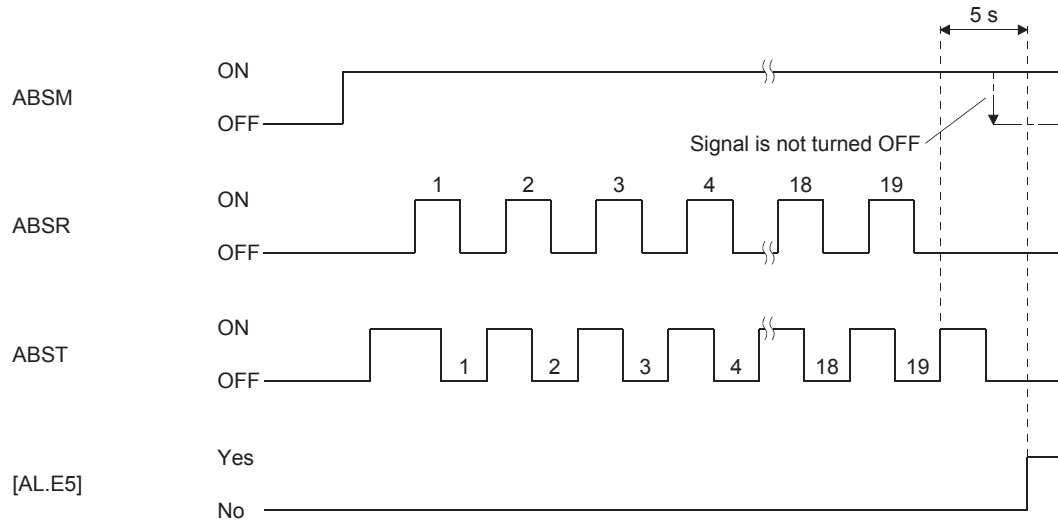

4) ABSM-off check during the ABS transfer

When the ABSM is turned on to start transferring and then the ABS transfer mode is turned off before the 19th ABS transmission data ready is turned on, [AL. E5 ABS time-out warning] occurs, regarding it as a transfer error.

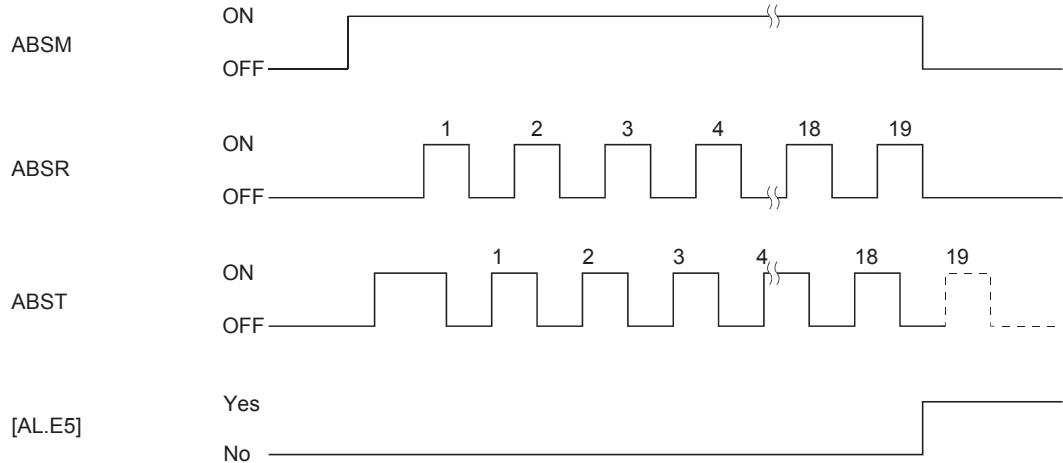

12. ABSOLUTE POSITION DETECTION SYSTEM

5) SON off, RES on, and EM2 off check during the ABS transfer

When the ABS transfer mode is turned on to start transferring and then SON is turned off, RES is turned on, or EM2 is turned on before the 19th ABST is turned on, [AL. E5 ABS time-out warning] occurs, regarding it as a transfer error.

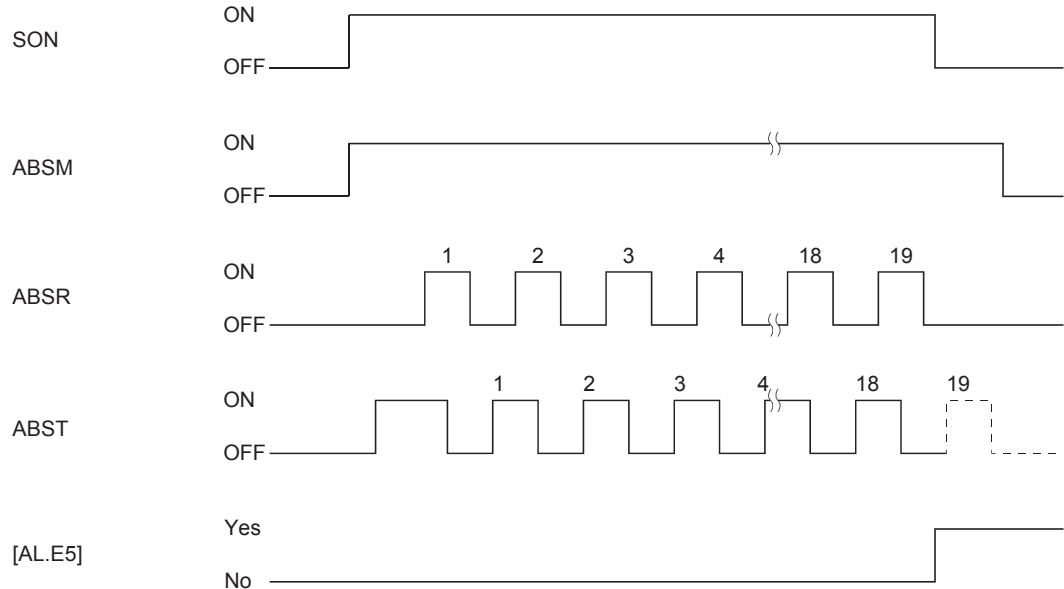

(b) Checksum error

If the checksum error occurs, the programmable controller should retry transmission of the ABS data.

Using the ladder check program of the programmable controller, turn off ABSM. After a lapse of 10 ms or longer, turn off SON (off time should be longer than 20 ms) and then turn it on again.

If the ABS data transmission fails even after retry, process the ABS checksum error.

The start command should be interlocked with ABST to disable positioning operation when an checksum error occurs. The following shows an example of three retries.

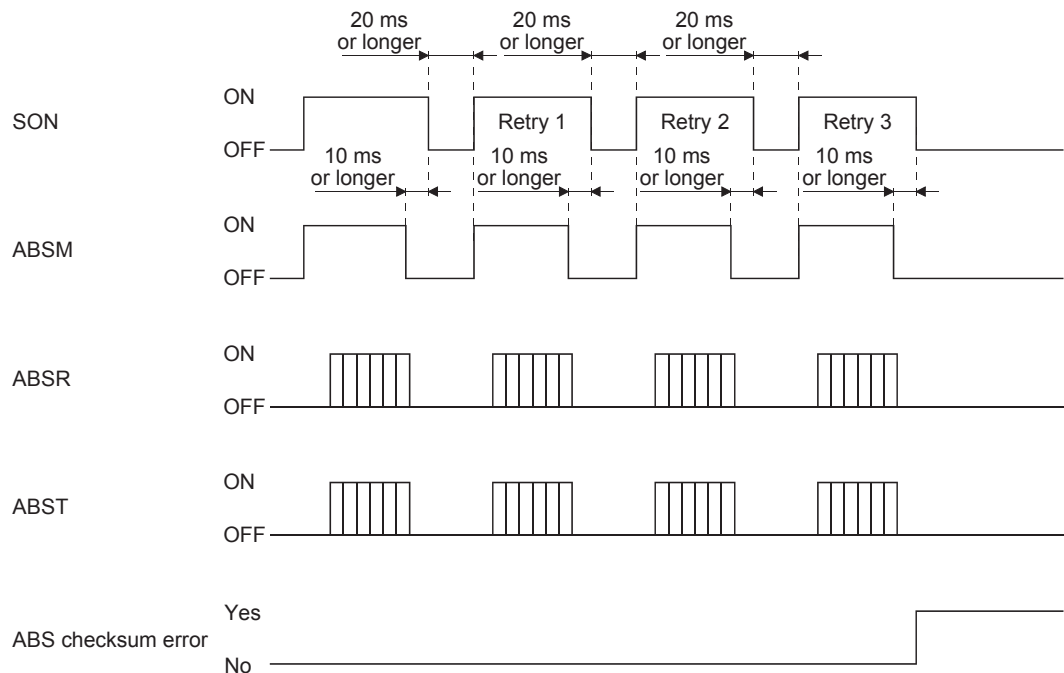

12. ABSOLUTE POSITION DETECTION SYSTEM

(3) At the time of alarm reset

If an alarm occurs, turn off SON by detecting ALM. If an alarm has occurred, ABSM cannot be accepted. In the reset state, ABSM can be input.

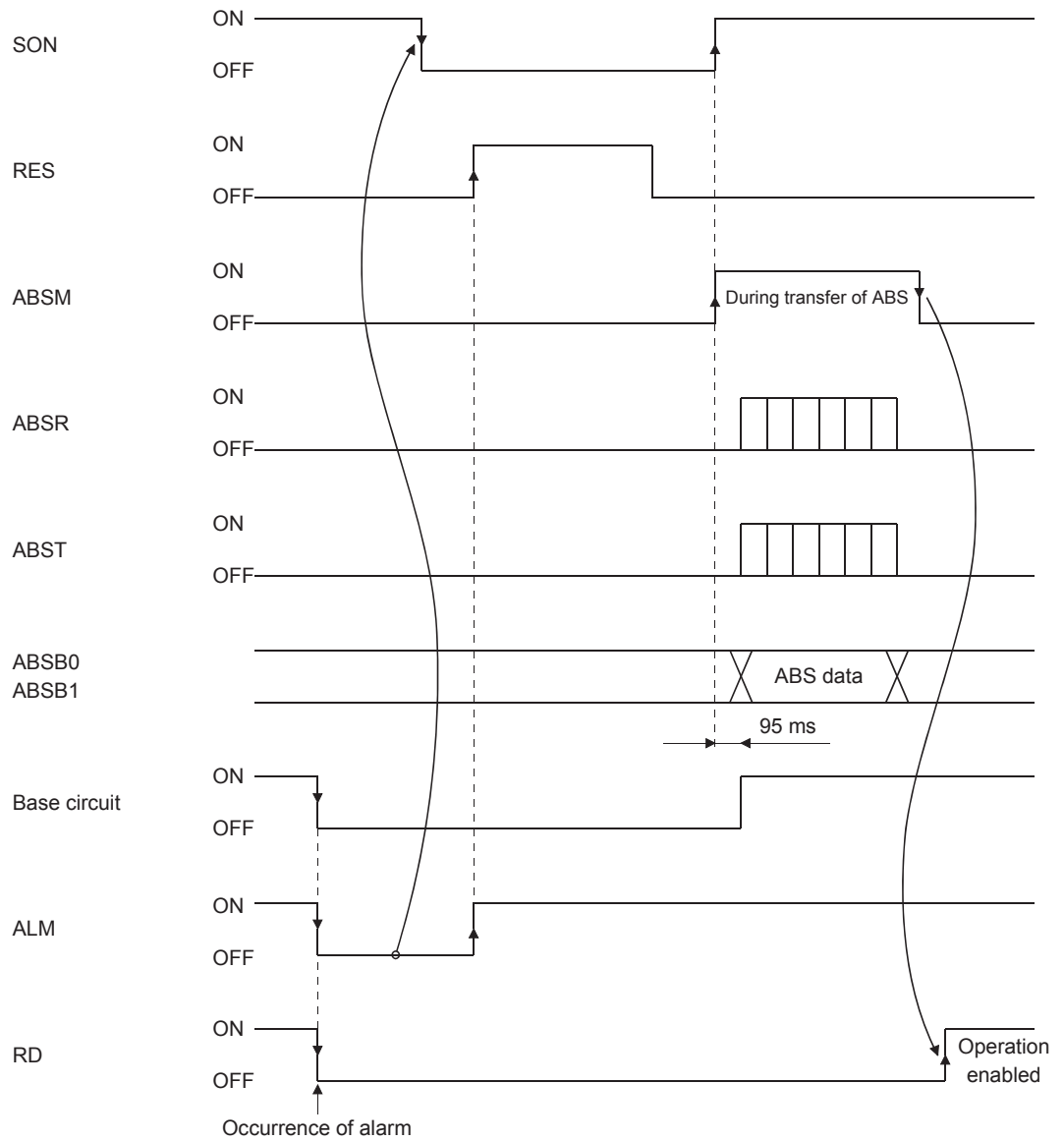

12. ABSOLUTE POSITION DETECTION SYSTEM

(4) At the time of forced stop reset

(a) If the power is switched on in the forced stop state

The forced stop state can be reset while the ABS data is being transferred. If the forced stop state is reset while the ABS data is transmitted, the base circuit is turned on 95 ms after resetting. If ABSM is off when the base circuit is turned on, RD is turned on 5 ms after the turning on of the base circuit. If ABSM is on when the base circuit is turned on, it is turned off and then RD is turned on. The ABS data can be transmitted after the forced stop state is reset.

The current position in the servo amplifier is updated even during an forced stop. When SON and ABSM are turned on during an forced stop as shown below, the servo amplifier transmits to the controller the current position latched when ABSM switches from off to on, and at the same time, the servo amplifier sets this data as a position command value. However, since the base circuit is off during an forced stop, the servo-lock status is not encountered. Therefore, if the servo motor is rotated by external force or the like after ABSM is turned on, this travel distance is accumulated in the servo amplifier as droop pulses. If the forced stop is cleared in this status, the base circuit turns on and the motor returns to the original position rapidly to compensate for the droop pulses. To avoid this status, reread the ABS data before clearing the forced stop.

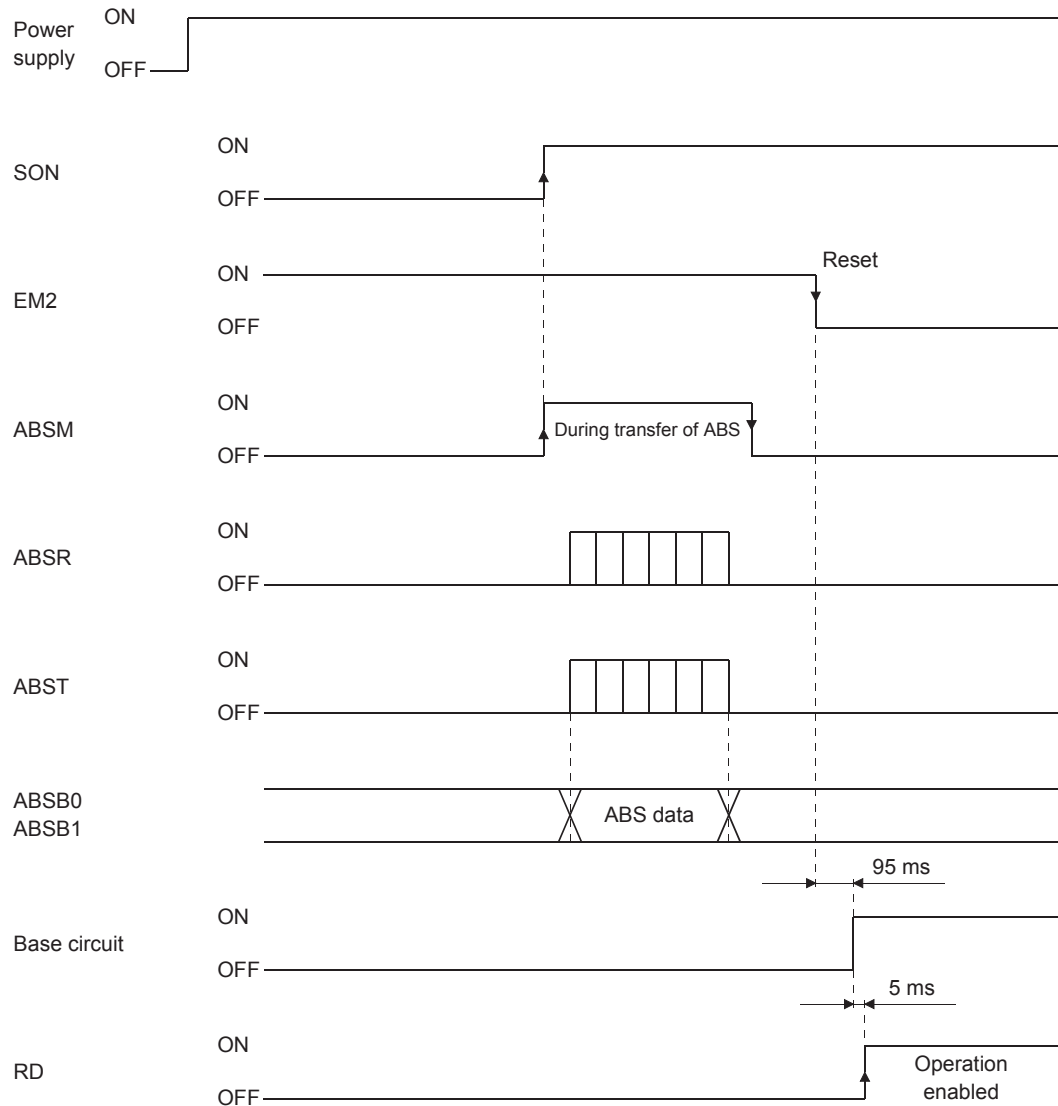

12. ABSOLUTE POSITION DETECTION SYSTEM

(b) If forced stop is activated during servo-on

ABSM is permissible while in the forced stop state. In this case, the base circuit and RD are turned on after the forced stop state is reset.

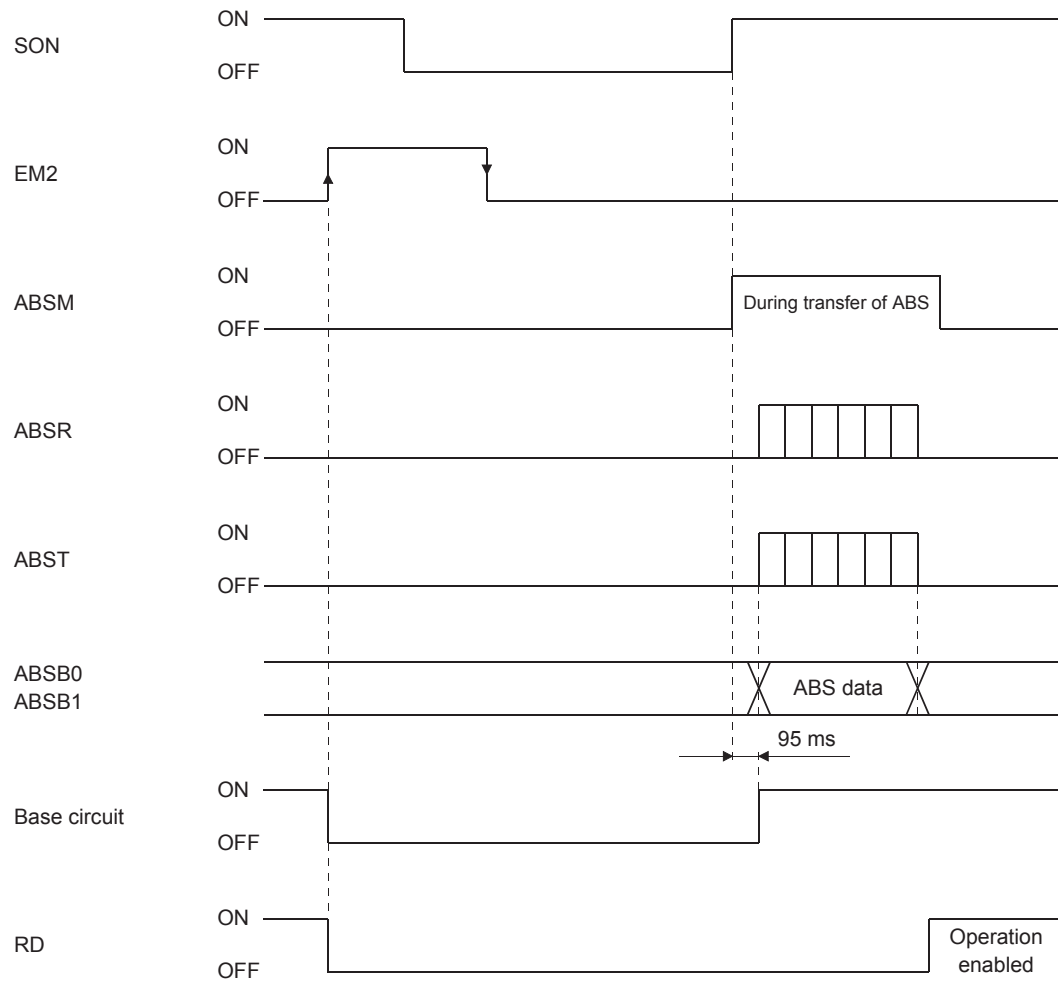

12. ABSOLUTE POSITION DETECTION SYSTEM

12.8.3 Home position setting

(1) Dog type home position return

Preset a home position return creep speed at which the machine will not be given impact.

On detection of a zero pulse, CR is turned from off to on. At the same time, the servo amplifier clears the droop pulses, comes to a sudden stop, and stores the stop position into the non-volatile memory as the home position ABS data.

CR should be turned on after it has been confirmed that INP is on. If this condition is not satisfied, [AL. 96 Home position setting error] will occur, but that warning will be reset automatically by making home position return correctly.

The number of home position setting times is limited to 1,000,000 times.

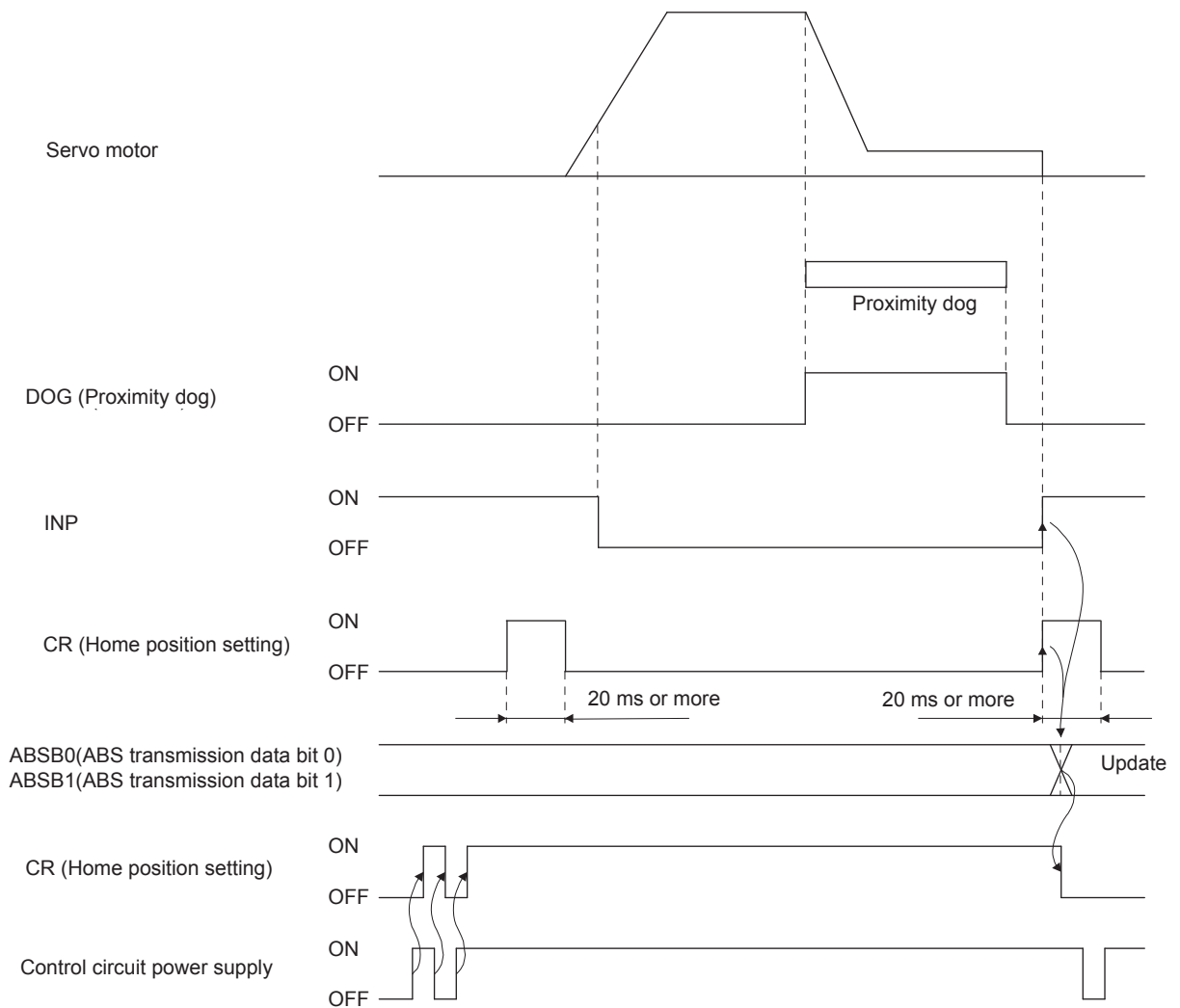

12. ABSOLUTE POSITION DETECTION SYSTEM

(2) Data set type home position return

| POINT |
|--|
| <ul style="list-style-type: none"> ● Never make home position setting during command operation or servo motor rotation. It may cause home position shift. ● It is possible to execute data set type home position return when the servo off. |

Move the machine to the position where the home position is to be set by performing manual operation such as JOG operation. When CR is on for longer than 20 ms, the stop position is stored into the non-volatile memory as the home position ABS data.

When the servo on, set CR to on after confirming that INP is on. If this condition is not satisfied, [AL. 96 Home position setting error] will occur, but that warning will be reset automatically by making home position return correctly.

The number of home position setting times is limited to 1,000,000 times.

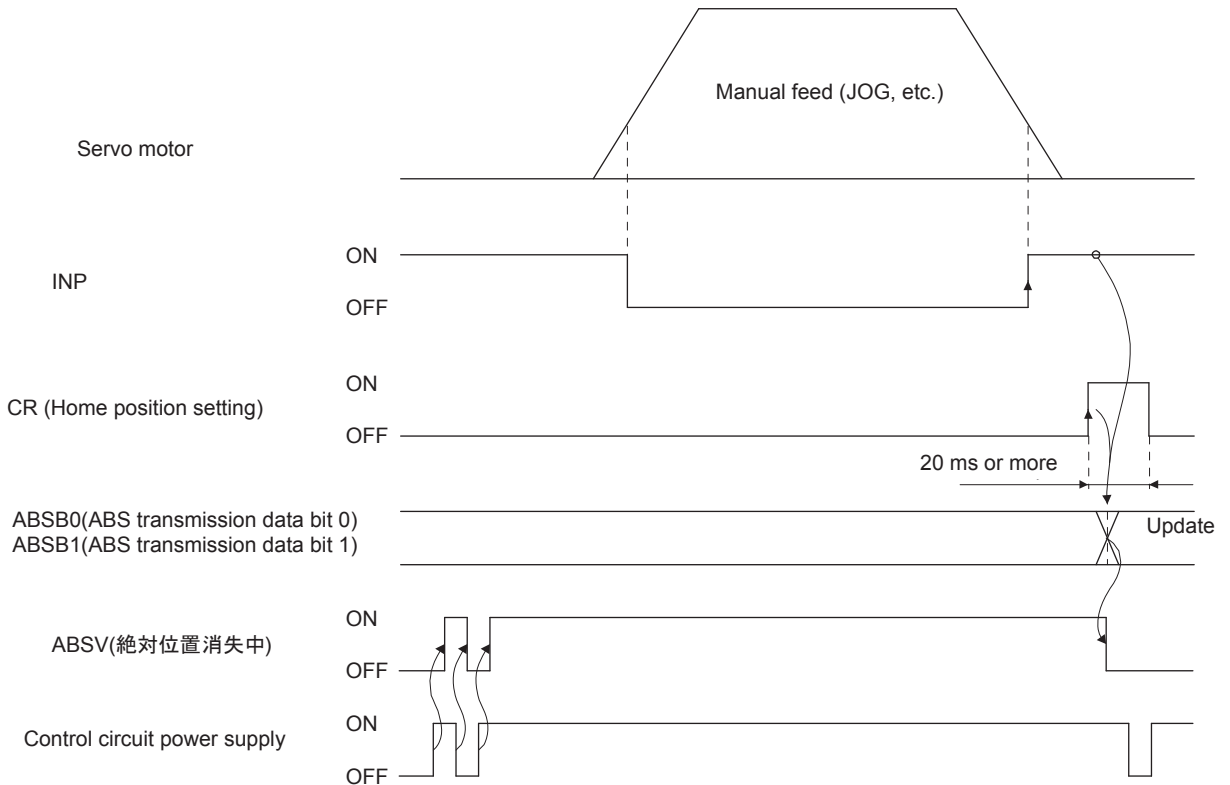

12. ABSOLUTE POSITION DETECTION SYSTEM

12.8.4 Use of servo motor with an electromagnetic brake

The timing charts at power on/off and SON on/off are given below.

Preset [Pr.PD03] to [Pr.PD22] of the servo amplifier to make MBR valid.

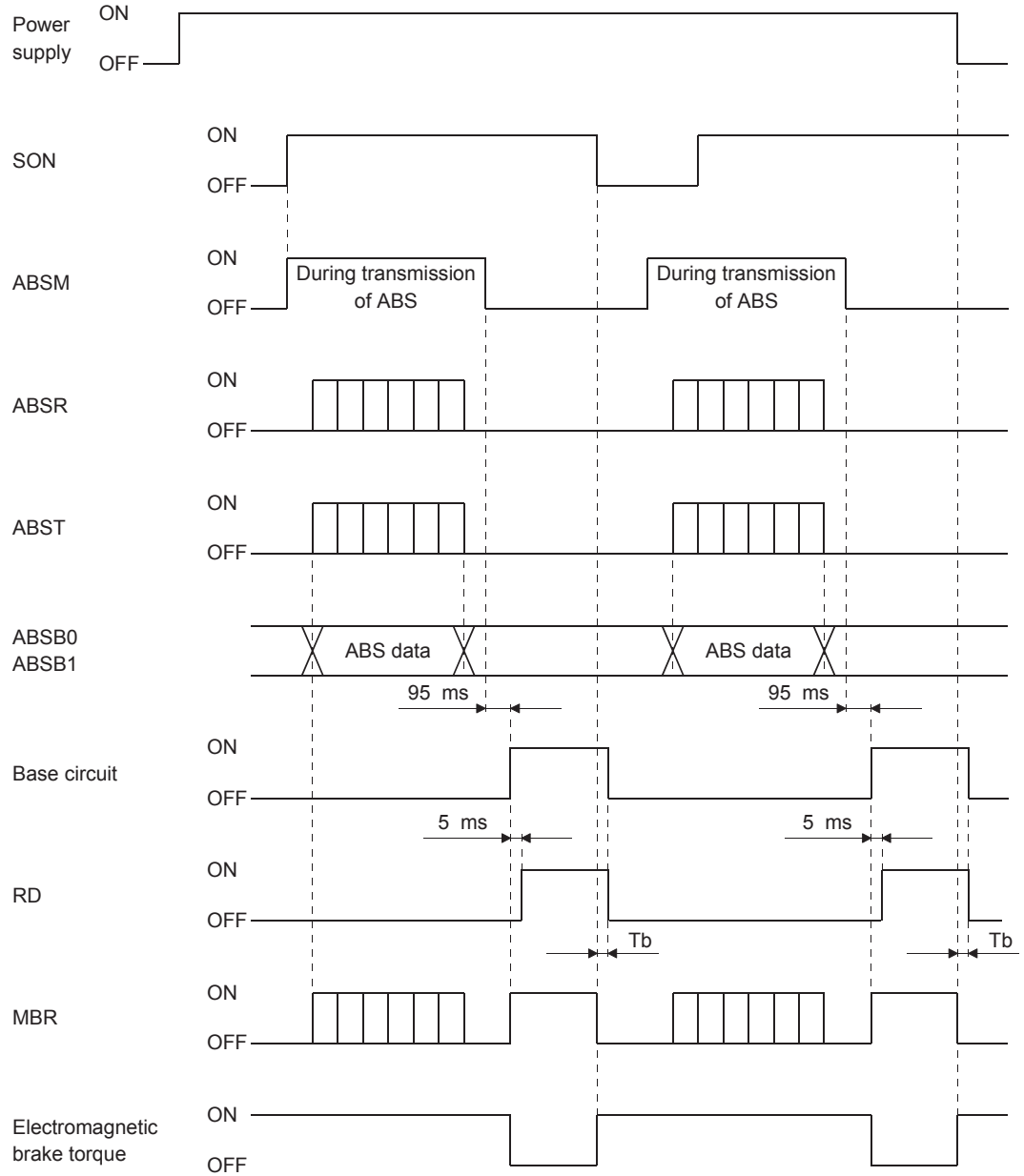

12. ABSOLUTE POSITION DETECTION SYSTEM

12.8.5 How to process the absolute position data at detection of stroke end

The servo amplifier stops the acceptance of the command pulse when LSP or LSN are detected, clears the droop pulses to 0 at the same time, and stops the servo motor. At this time, the programmable controller keeps outputting the command pulse. Since this causes a discrepancy between the absolute position data of the servo amplifier and the programmable controller, a difference will occur between the position data of the servo amplifier and that of the programmable controller. To prevent this difference in position data from occurring, do as described below. When the servo amplifier has detected the stroke end, perform JOG operation or the like to clear the stroke end.

After that, switch SON off once, then on again, or switch the power off once, then on again. This causes the absolute position data of the servo amplifier to be transferred to the programmable controller, restoring the normal data.

12.9 Absolute position data transfer errors

| |
|------|
| ポイント |
|------|

- When the following alarm or warning occurs, refer to MELSERVO-J4 Servo Amplifier Instruction Manual (Troubleshooting) to remove the failure.
 - [AL. 25 Absolute position erased]
 - [AL. 96 Home position setting warning]
 - [AL. E3 Absolute position counter warning]
 - [AL. E5 ABS time-out warning]
 - [AL. EA ABS servo-on warning]

12. ABSOLUTE POSITION DETECTION SYSTEM

- (1) The off period of the ABS transmission data ready signal output from the servo amplifier is checked. If the off period is 1 s or longer, this is regarded as a transfer fault and the ABS communication error is generated. The ABS communication error occurs if [AL. E5 ABS time-out warning] is generated at the servo amplifier due to an ABS request on time time-out.

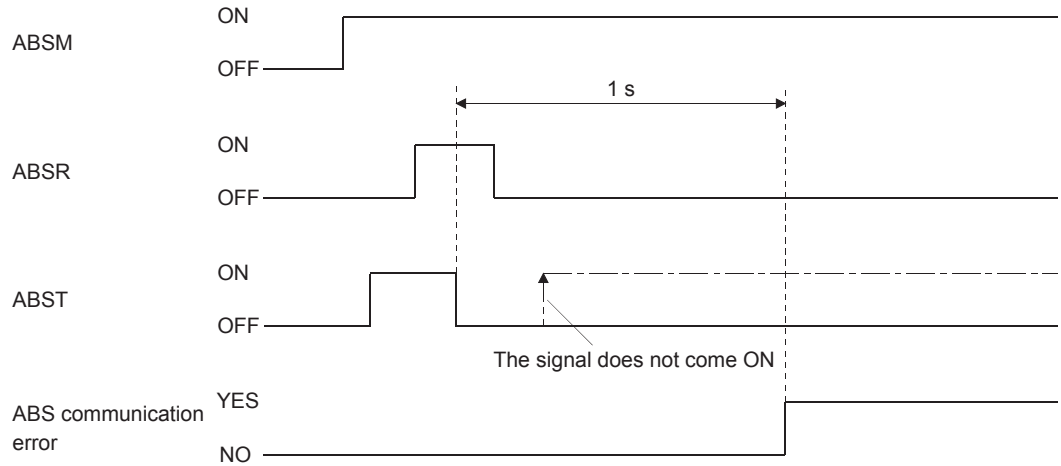

- (2) The time required for the ABS transfer mode signal to go off after it has been turned on (ABS transfer time) is checked. If the ABS transfer time is longer than 5 s, this is communication error occurs if [AL. E5 ABS time-out warning] is generated at the servo amplifier due to an ABS transfer mode completion time time-out.

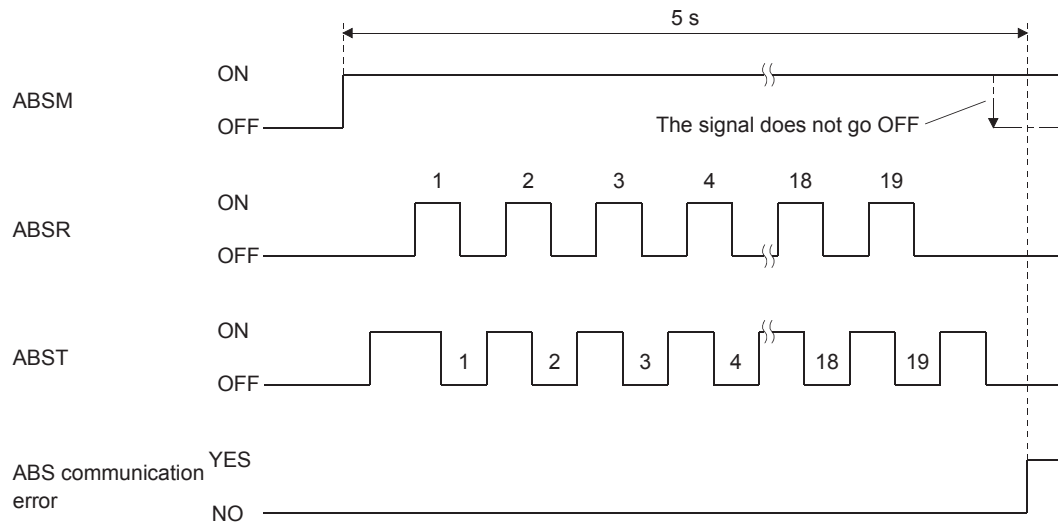

12. ABSOLUTE POSITION DETECTION SYSTEM

- (3) The time required for the ABS request signal to go off after it has been turned on (ABS request time) is checked. To detect [AL. E5 ABS time-out warning] at the servo amplifier. If the ABS request remains on for longer than 1 s, it is regarded that a fault relating to the ABS request signal or the ABST has occurred, and the ABS communication error is generated. The ABS communication error occurs if [AL. E5 ABS time-out warning] is generated at the servo amplifier due to an ABS request off time time-out.

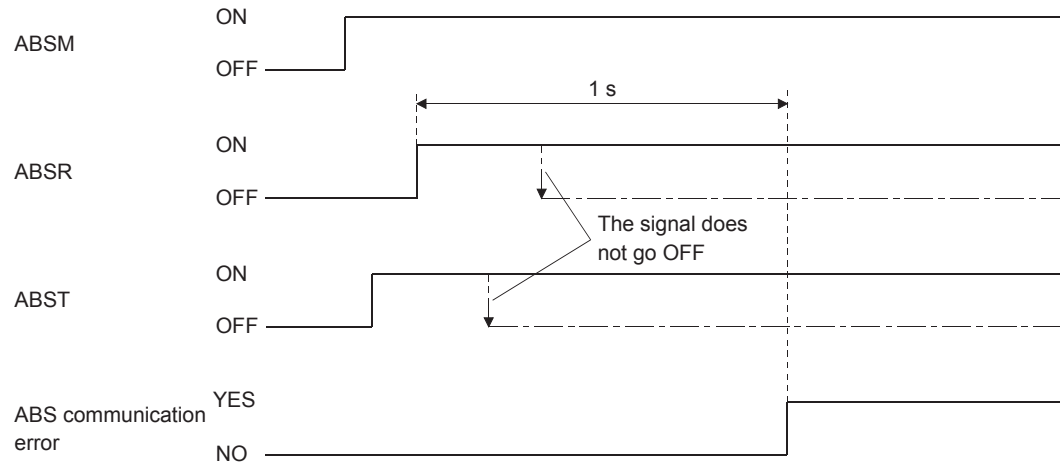

12. ABSOLUTE POSITION DETECTION SYSTEM

12.10 Communication-based ABS transfer system (available in the future)

12.10.1 Serial communication command

The following commands are available for reading absolute position data using the serial communication function. When reading data, take care to specify the correct station number of the drive unit from where the data will be read.

When the master station sends the data No. to the slave station (servo amplifier), the slave station returns the data value to the master station.

(1) Transmission

Transmit command [0][2] and data No. [9][1].

(2) Reply

The absolute position data in the command pulse unit is returned in hexadecimal.

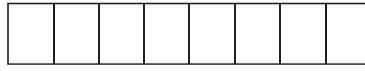

Data 32-bit length (hexadecimal representation)

12.10.2 Absolute position data transfer protocol

(1) Data transfer procedure

Every time SON turns on at power-on or like, the controller must read the current position data in the servo amplifier. Not performing this operation will cause a position shift.

Time-out monitoring is performed by the controller.

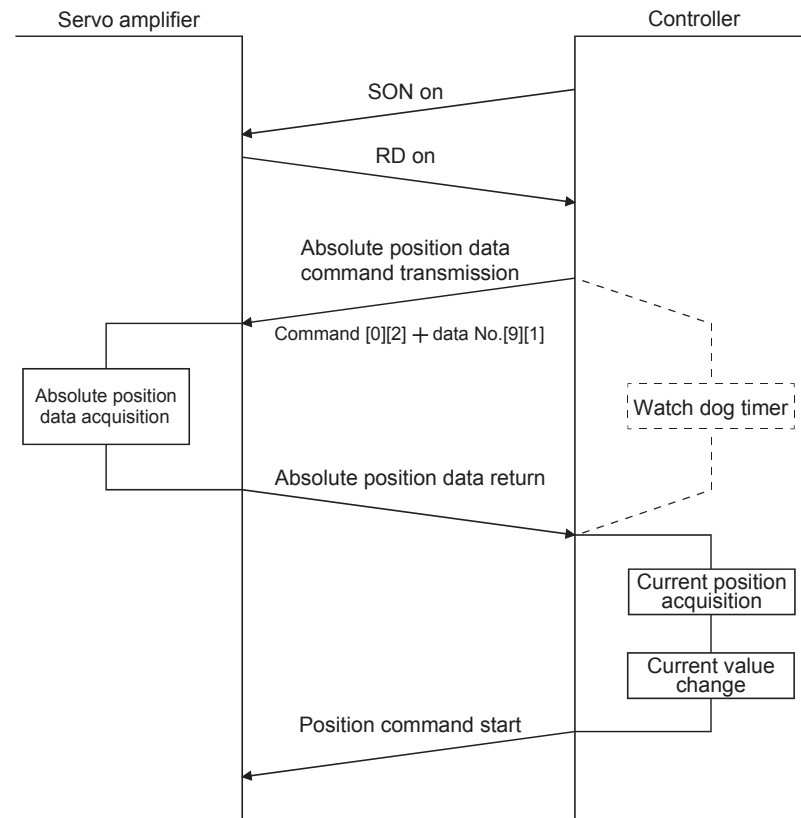

12. ABSOLUTE POSITION DETECTION SYSTEM

(2) Transfer method

The following shows a sequence how to turn on the base circuit while it is off state because SON is off, EM2 is off, or an alarm is occurring. In the absolute position detection system, always give the serial communication command to read the current position in the servo amplifier to the controller every time RD turns on. The servo amplifier sends the current position to the controller on receipt of the command. At the same time, this data is set as a position command value in the servo amplifier.

(a) Sequence processing at power-on

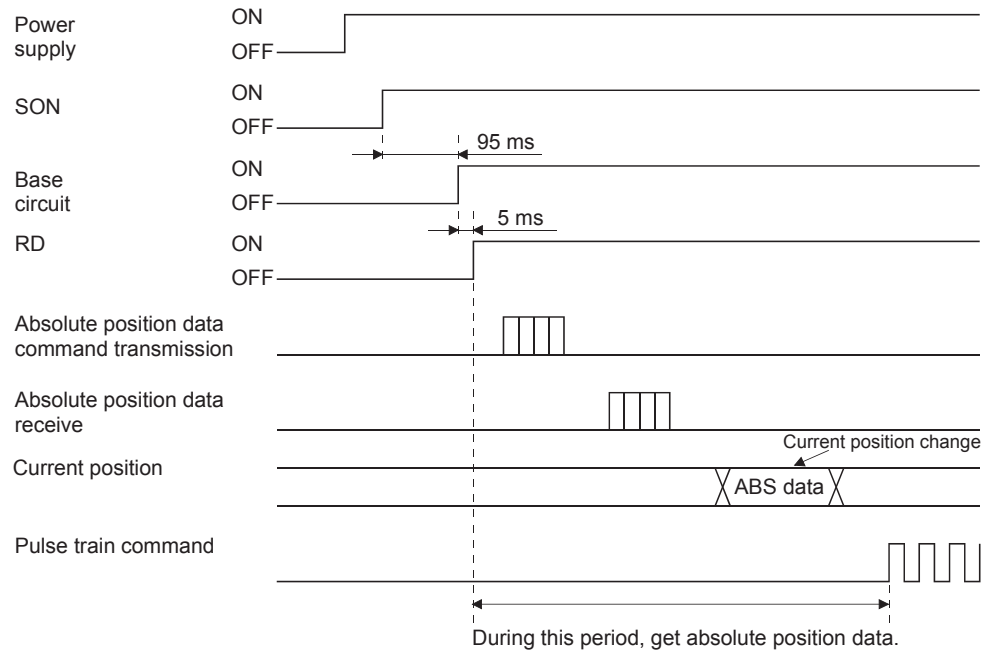

- 1) 95 ms after SON has turned on, the base circuit turns on.
- 2) After the base circuit has turned on, RD turns on.
- 3) After RD turned on and the controller acquired the absolute position data, give command pulses to the drive unit. Providing command pulses before the acquisition of the absolute position data can cause a position shift.

(b) Communication error

If a communication error occurs between the controller and servo amplifier, the servo amplifier sends the error code. The definition of the error code is the same as that of the communication function. If a communication error has occurred, perform retry operation. If several retries do not result in a normal termination, perform error processing.

12. ABSOLUTE POSITION DETECTION SYSTEM

(c) At the time of alarm reset

If an alarm has occurred, detect ALM and turn off SON. After removing the alarm occurrence factor and deactivating the alarm, get the absolute position data again from the servo amplifier in accordance with the procedure in (a) of this section.

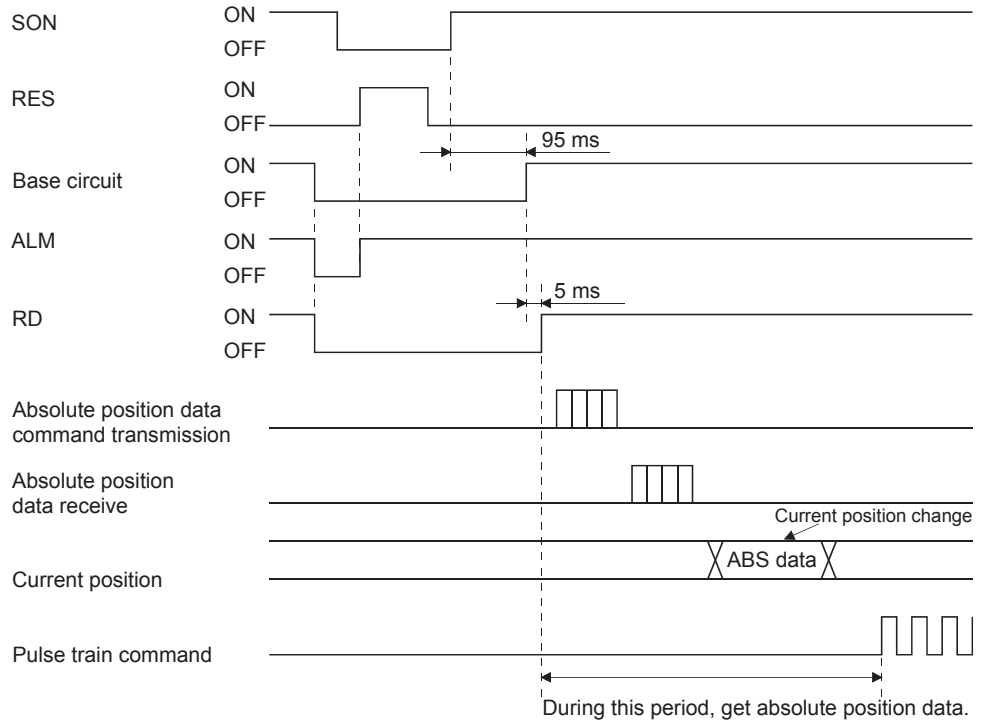

12. ABSOLUTE POSITION DETECTION SYSTEM

(d) At the time of forced stop reset

210 ms after the forced stop is deactivated, the base circuit turns on, and further 5 ms after that, turns on. Always get the current position data from when RD is triggered until before the position command is issued.

1) When power is switched on in a forced stop status

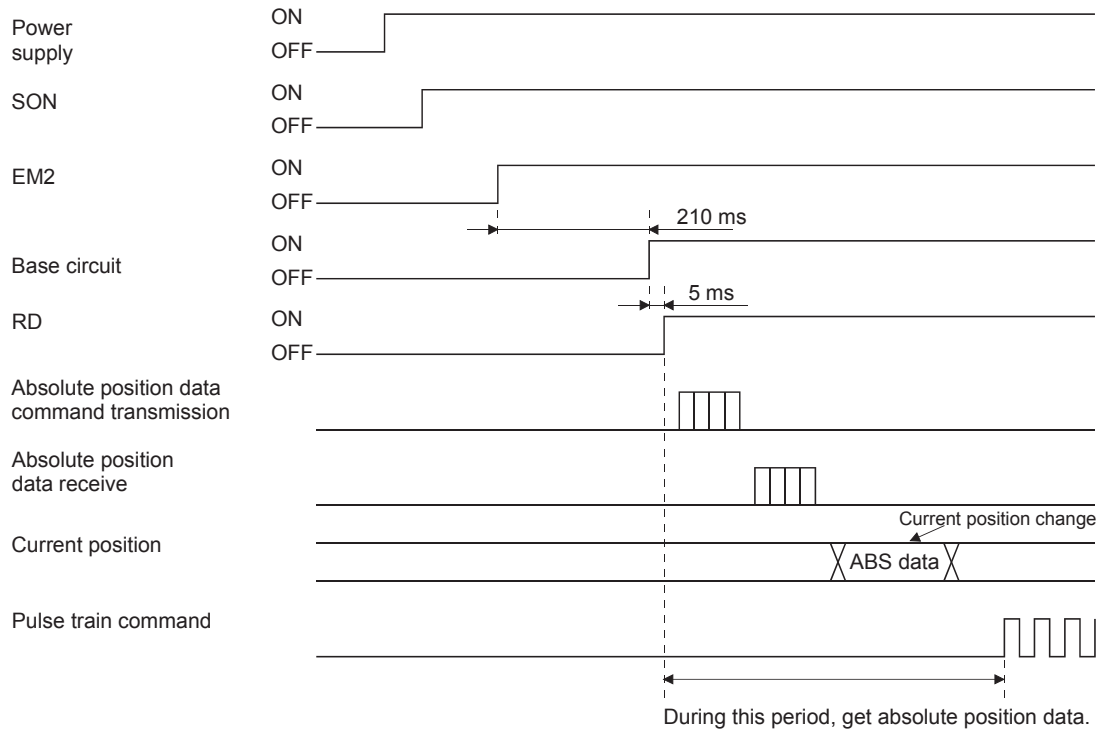

2) When a forced stop is activated during servo on

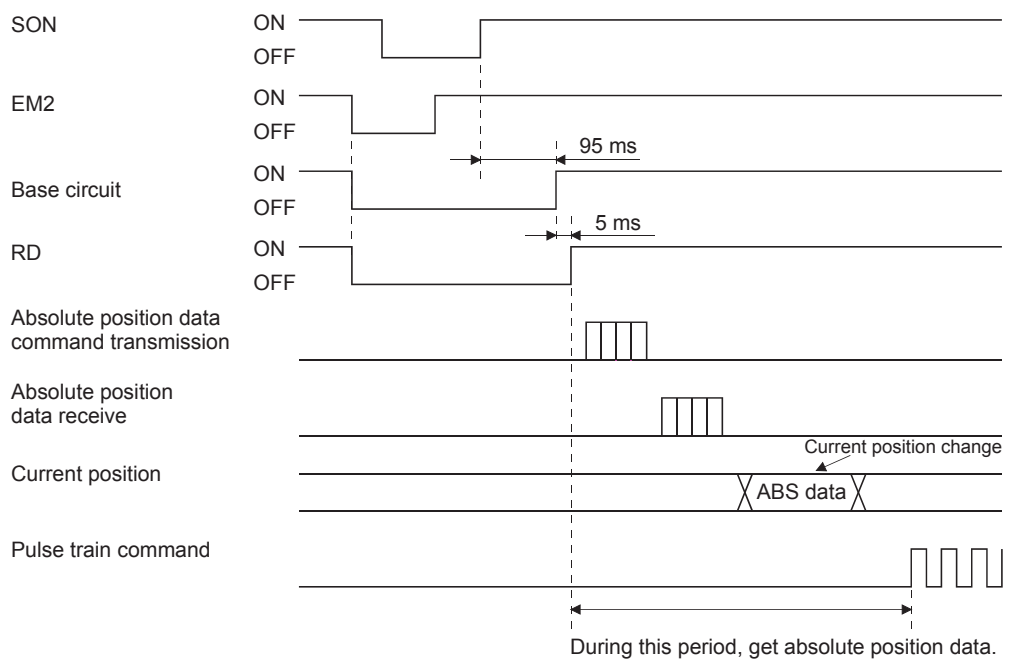

12. ABSOLUTE POSITION DETECTION SYSTEM

12.11 Confirmation of absolute position detection data

You can check the absolute position data with MR Configurator 2.

Choose "Diagnostics" and "Absolute Encoder Data" to open the absolute position data display screen.

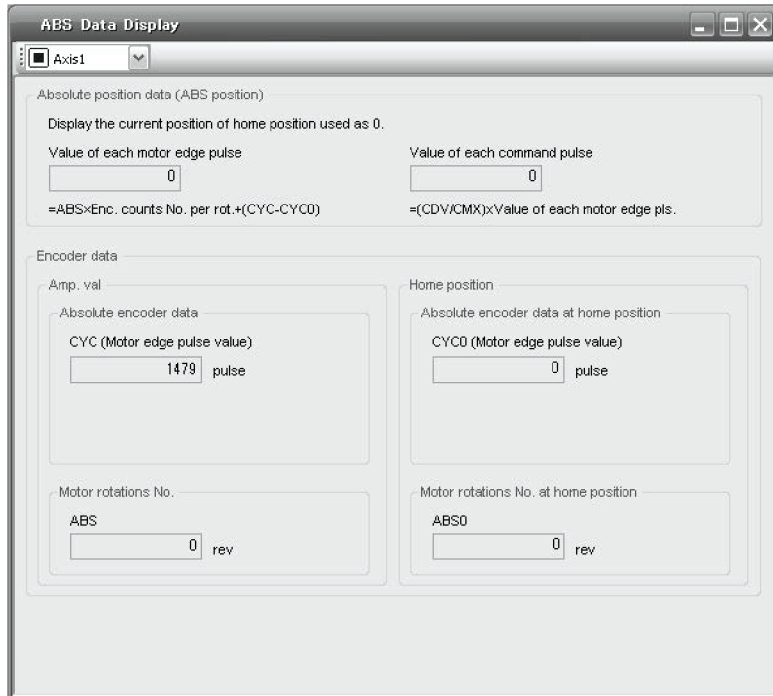

13. USING STO FUNCTION

13. USING STO FUNCTION

| |
|-------|
| POINT |
|-------|

| |
|---|
| ● In the torque control mode, the forced stop deceleration function is not available. |
|---|

13.1 Introduction

This section provides the cautions of the STO function.

13.1.1 Summary

This servo amplifier complies with the following safety standards.

- ISO/EN ISO 13849-1 category 3 PL d
- IEC/EN 61508 SIL 2
- IEC/EN 61800-5-2 SIL 2

13.1.2 Terms related to safety

The STO function shuts down energy to servo motors, thus removing torque. This function electronically cuts off power supply in the servo amplifier.

The purpose of this safety function is as follows.

- (1) Uncontrolled stop according to stop category 0 of IEC/EN 60204-1
- (2) Preventing unexpected start-up

13.1.3 Cautions

The following basic safety notes must be read carefully and fully in order to prevent injury to persons or damage to property.

Only qualified personnel are authorized to install, start-up, repair, or service the machines in which these components are installed.

They must be familiar with all applicable local regulations and laws in which machines with these components are installed, particularly the standards mentioned in this manual.

The staff responsible for this work must be given express permission from the company to perform start-up, programming, configuration, and maintenance of the machine in accordance with the safety standards.



● Improper installation of the safety related components or systems may cause improper operation in which safety is not assured, and may result in severe injuries or even death.

Protective Measures

- This servo amplifier satisfies the Safe Torque Off (STO) function described in IEC/EN 61800-5-2 by preventing the energy supply from the servo amplifier to the servo motor. If an external force acts upon the drive axis, additional safety measures, such as brakes or counterbalances must be used.

13. USING STO FUNCTION

13.1.4 Residual risks of the STO function

Machine manufacturers are responsible for all risk evaluations and all associated residual risks. Below are residual risks associated with the STO function. Mitsubishi is not liable for any damages or injuries caused by these risks.

- (1) The STO function disables energy supply to the servo motor by electrical shut-off. The function does not mechanically disconnect electricity from the motor. Therefore, it cannot prevent exposure to electric shock. To prevent an electric shock, install a magnetic contactor or a molded case circuit breaker to the main circuit power supply (L1, L2, and L3) of the servo amplifier.
- (2) The STO function disables energy supply to the servo motor by electrical shut-off. It does not guarantee the stop control or the deceleration control of the servo motor.
- (3) For proper installation, wiring, and adjustment, thoroughly read the manual of each individual safety related component.
- (4) In the safety circuit, use components that are confirmed safe or meet the required safety standards.
- (5) The STO function does not guarantee that the drive part of the servo motor will not rotate due to external or other forces.
- (6) Safety is not assured until safety-related components of the system are completely installed or adjusted.
- (7) When replacing this servo amplifier, confirm that the model name of servo amplifiers are exactly the same as those being replaced. Once installed, make sure to verify the performance of the safety functions before commissioning the system.
- (8) Perform all risk assessments to the machine or the whole system.
- (9) To prevent accumulation of malfunctions, perform malfunction checks at regular intervals based on the risk assessments of the machine or the system. Regardless of the system safety level, malfunction checks should be performed at least once per year.
- (10) If the upper and lower power module in the servo amplifier are shorted and damaged simultaneously, the servo motor may make a half revolution at a maximum.
- (11) The STO input signals (STO1 and STO2) must be supplied from one power source. Otherwise, the STO function may not function properly due to a sneak current, failing to bring the STO shut-off state.
- (12) For the STO I/O signals of the STO function, supply power by using a safety extra low voltage (SELV) power supply with the reinforced insulation.

13. USING STO FUNCTION

13.1.5 Specifications

(1) Specifications

| Item | Specifications |
|--|--|
| Safety function | STO (IEC/EN 61800-5-2) |
| Safety performance (Certification standards) | ISO/EN ISO 13849-1 category 3 PL d, IEC/EN 61508 SIL 2, EN 62061 SIL CL2, EN 61800-5-2 SIL 2 |
| Mean time to dangerous failure (MTTFd) (available in the future) | 100 years (Note) |
| Diagnostic converge (DC) | 90% (Note) |
| Average probability of dangerous failures per hour (PFH) [1/h] | 1.01×10^{-7} (Note) |
| Number of ON/OFF times of STO | 1,000,000 times |
| CE marking | LVD: EN 61800-5-1 EMC: EN 61800-3 MD: EN ISO 13849-1, EN 61800-5-2, EN 62061 |

Note. This is the value required by safety standards.

(2) Function block diagram (STO function)

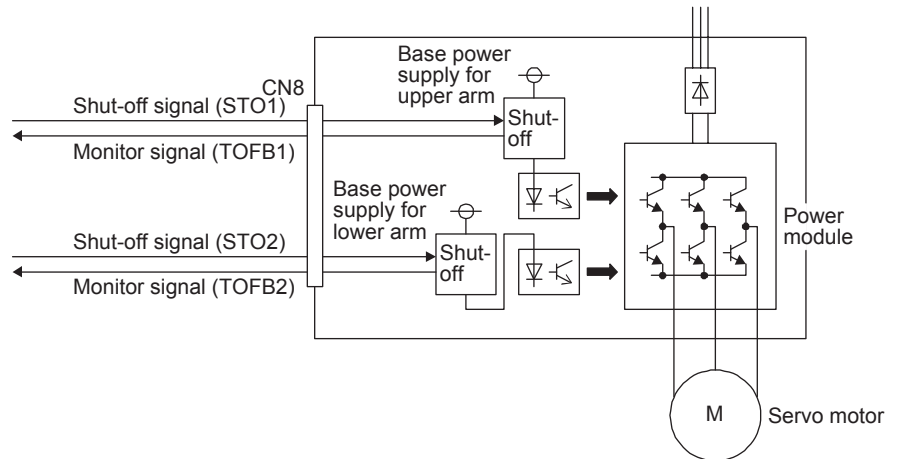

(3) Operation sequence (STO function)

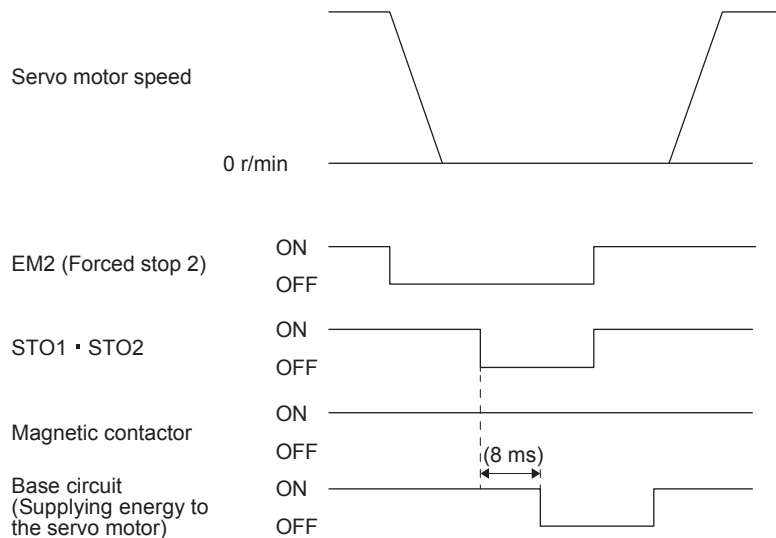

13. USING STO FUNCTION

13.1.6 Maintenance

This servo amplifier has alarms and warnings for maintenance that supports the Mitsubishi drive safety function. (Refer to chapter 8.)

13.2 STO I/O signal connector (CN8) and signal layouts

13.2.1 Signal layouts

| |
|---|
| POINT |
| ● The pin configurations of the connectors are as viewed from the cable connector wiring section. |

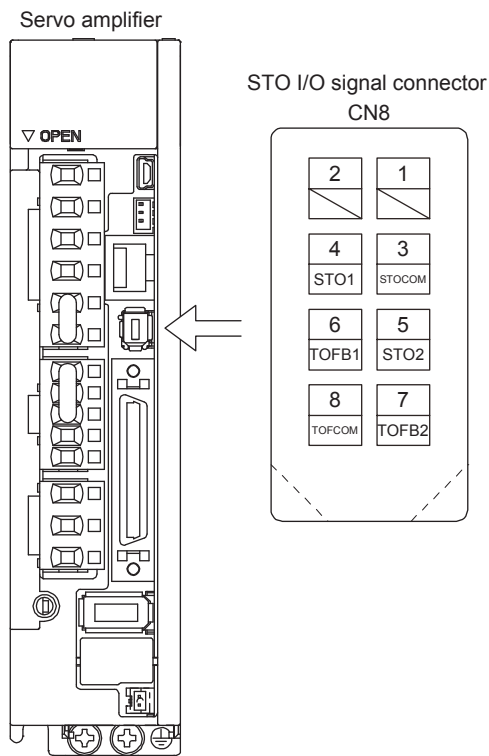

13. USING STO FUNCTION

13.2.2 Signal (device) explanations

(1) I/O device

| Signal name | Connector pin No. | Description | I/O division |
|-------------|-------------------|---|--------------|
| STOCOM | CN8-3 | Common terminal for input signal of STO1 and STO2 | DI-1 |
| STO1 | CN8-4 | Inputs STO state 1. STO state (base shut-off): Open between STO1 and STOCOM. STO release state (in driving): Close between STO1 and STOCOM. Be sure to turn off STO1 after the servo motor stops by the servo-off state or with forced stop deceleration by turning off EM2 (Forced stop 2). | DI-1 |
| STO2 | CN8-5 | Inputs STO state 2. STO state (base shut-off): Open between STO2 and STOCOM. STO release state (in driving): Close between STO2 and STOCOM. Be sure to turn off STO2 after the servo motor stops by the servo-off state or with forced stop deceleration by turning off EM2 (Forced stop 2). | DI-1 |
| TOFCOM | CN8-8 | Common terminal for monitor output signal in STO state | DO-1 |
| TOFB1 | CN8-6 | Monitor output signal in STO1 state STO state (base shut-off): Between TOFB1 and TOFCOM is closed. STO release state (in driving): Between TOFB1 and TOFCOM is opened. | DO-1 |
| TOFB2 | CN8-7 | Monitor output signal in STO2 state STO state (base shut-off): Between TOFB2 and TOFCOM is closed. STO release state (in driving): Between TOFB2 and TOFCOM is opened. | DO-1 |

(2) Signals and STO state

The following table shows the TOFB and STO states when the power is on in normal state and STO1 and STO2 are on (closed) or off (opened).

| Input signal | | State | | |
|--------------|------|---|---|--|
| STO1 | STO2 | Between TOFB1 and TOFCOM (Monitoring STO1 state) | Between TOFB2 and TOFCOM (Monitoring STO2 state) | Between TOFB1 and TOFB2 (Monitoring STO state of servo amplifier) |
| OFF | OFF | ON: STO state (base circuit shut-off) | ON: STO state (base circuit shut-off) | ON: STO state (base circuit shut-off) |
| OFF | ON | ON: STO state (base circuit shut-off) | OFF: STO release state | ON: STO state (base circuit shut-off) |
| ON | OFF | OFF: STO release state | ON: STO state (base circuit shut-off) | ON: STO state (base circuit shut-off) |
| ON | ON | OFF: STO release state | OFF: STO release state | OFF: STO release state |

(3) Test pulse of STO input signal

The test pulse off time is 1 ms or less.

13.2.3 How to pull out the STO cable

The following shows how to pull out the STO cable from the CN8 connector of the servo amplifier.

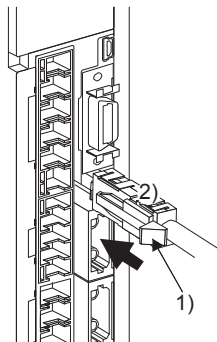

While pressing knob 1) of the STO cable plug in the direction of the arrow, pull out the plug 2).
(This figure shows the MR-J4-B servo amplifier. This procedure also applies to the MR-J4-A servo amplifier.)

13. USING STO FUNCTION

13.3 Connection example

| POINT | |
|-------|---|
| ● | Turn off STO (STO1 and STO2) after the servo motor stops by the servo off state or with forced stop deceleration by turning off EM2 (Forced stop 2). Configure an external sequence that has the timings shown as below using an external device such as the MR-J3-D05 safety logic unit. |
| | |
| ● | If STO is turned off during operation, the servo motor is in dynamic brake stop (stop category 0), and [AL.63 STO timing error] will occur. |

13.3.1 Connection example for CN8 connector

This servo amplifier is equipped with the connector (CN8) in accordance with the STO function. When this connector is used with a certified external safety relay, power to the motor can be safely removed and unexpected restart can be prevented. The safety relay used should meet the applicable safety standards and have forcibly guided or mirror contacts for the purpose of error detection.

In addition, the MR-J3-D05 safety logic unit can be used instead of a safety relay for implementation of various safety standards. Refer to Appendix 7 for details.

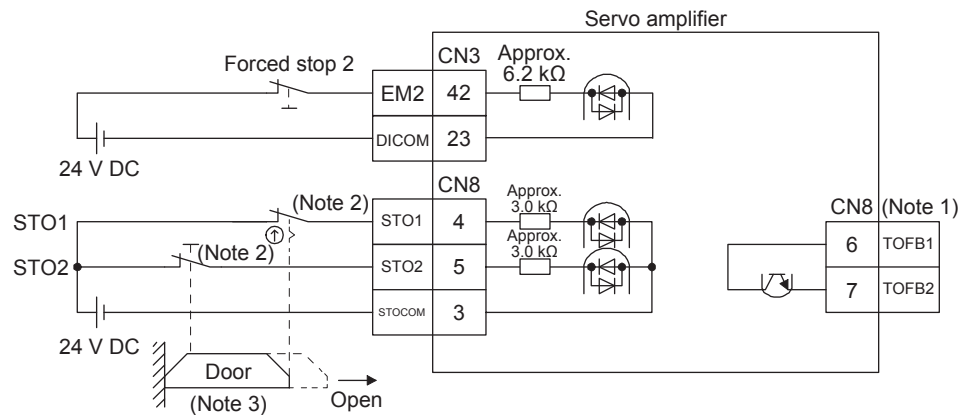

Note 1. By using TOFB, whether the servo is in the STO state can be confirmed. For connection examples, refer to section 13.3.2 to 13.3.4.

Note 2. When using the STO function, turn off STO1 and STO2 at the same time. Turn off STO1 and STO2 after the servo motor stops by the servo off state or with forced stop deceleration by turning off EM2 (Forced stop 2).

Note 3. Configure the interlock circuit so that the door is open after the servo motor is stopped.

13. USING STO FUNCTION

13.3.2 External I/O signal connection example using a MR-J3-D05 safety logic unit

POINT

● This connection is for the source interface.

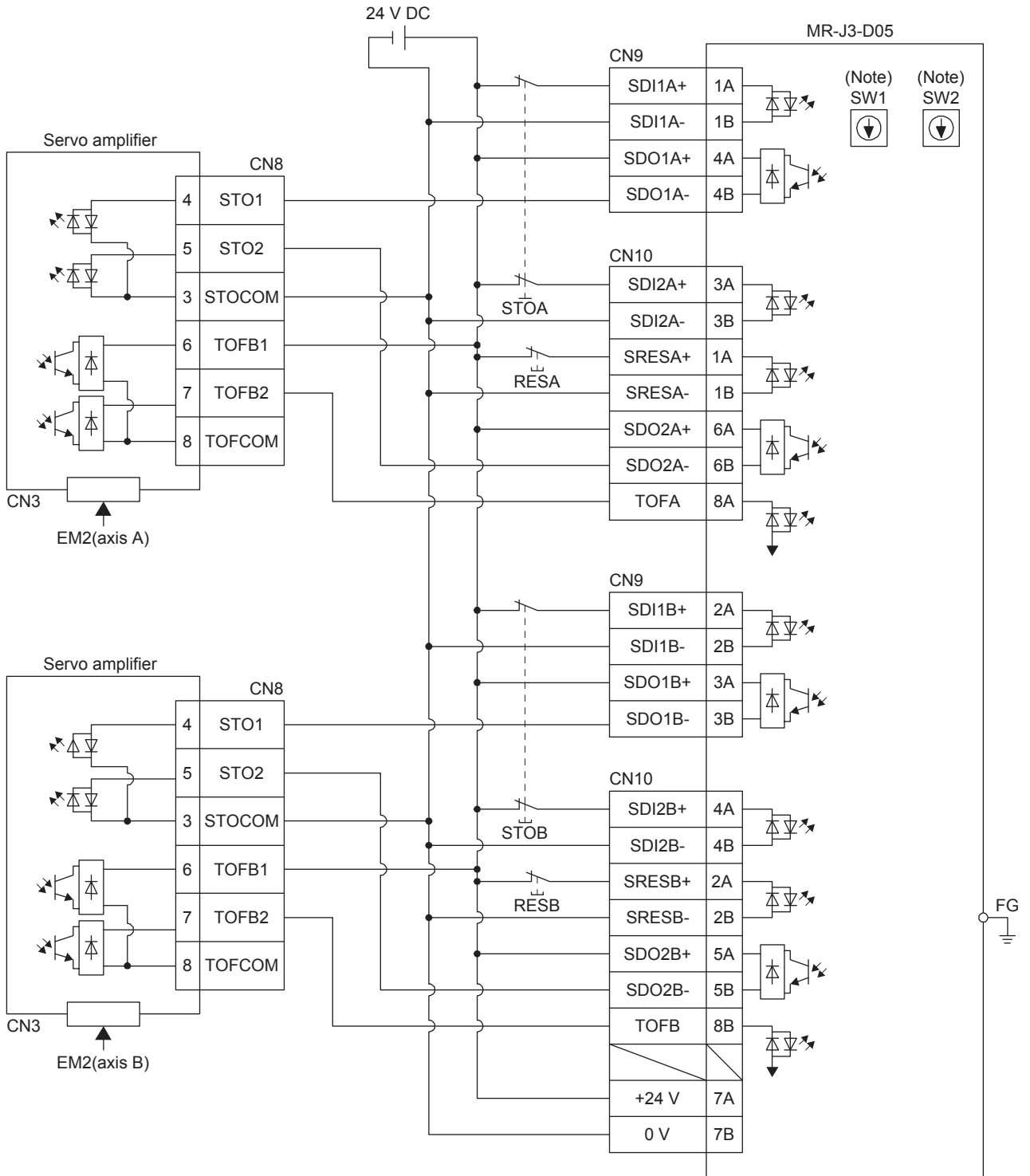

Note. Set the delay time of STO output with SW1 and SW2. These switches are located where denoted from the front panel.

13. USING STO FUNCTION

13.3.3 External I/O signal connection example using an external safety relay unit

| |
|--|
| POINT |
| ● This connection is for the source interface. |

This connection example complies with the requirement of ISO/EN ISO 13849-1 category 3 PL d. For details, refer to the safety relay module user's manual.

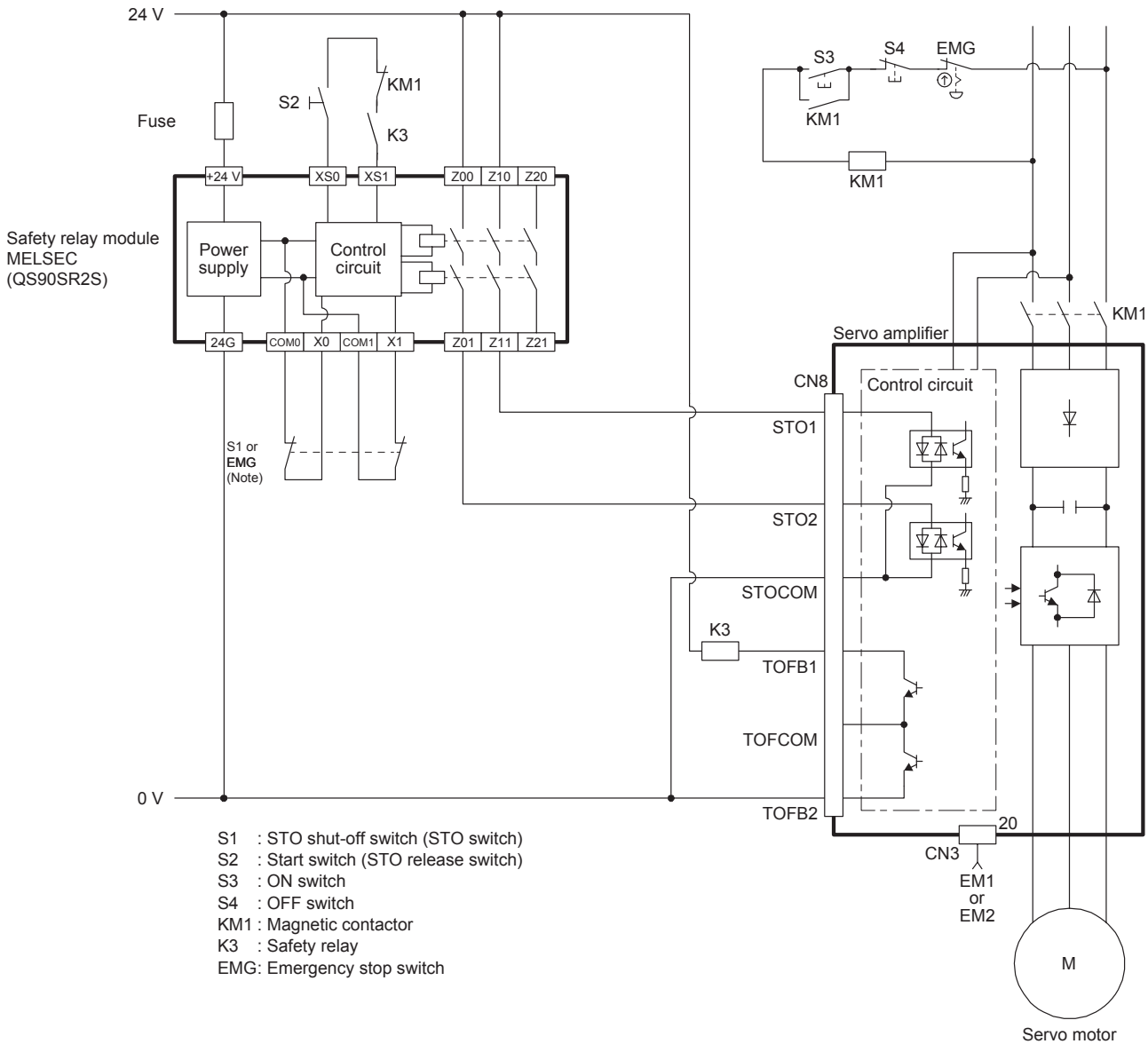

Note. To enable the STO function of the servo amplifier by using "Emergency switching off", change S1 to EMG. The stop category at this time is "0". If STO is turned off while the servo motor is rotating, [AL. 63 STO timing error] will occur.

13. USING STO FUNCTION

13.4 Detailed description of interfaces

This section provides the details of the I/O signal interfaces (refer to the I/O division in the table) given in section 13.2. Refer to this section and make connection with the external device.

13.4.1 Sink I/O interface

(1) Digital input interface DI-1

Turn on/off the input signal with a relay or open collector transistor.

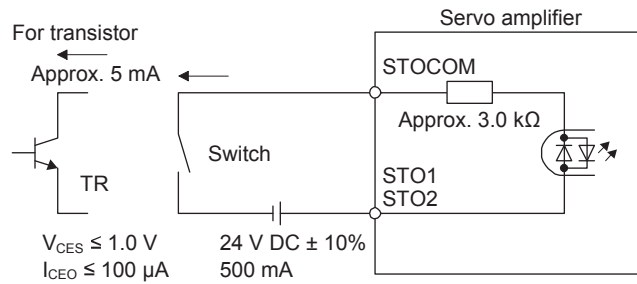

(2) Digital output interface DO-1

A lamp, relay or photocoupler can be driven. Install a diode (D) for an inductive load, or install an inrush current suppressing resistor (R) for a lamp load.

(Rated current: 40 mA or less, maximum current: 50 mA or less, inrush current: 100 mA or less) A maximum of 5.2 V voltage drop occurs in the servo amplifier.

(a) When outputting two STO states by using each TOFB

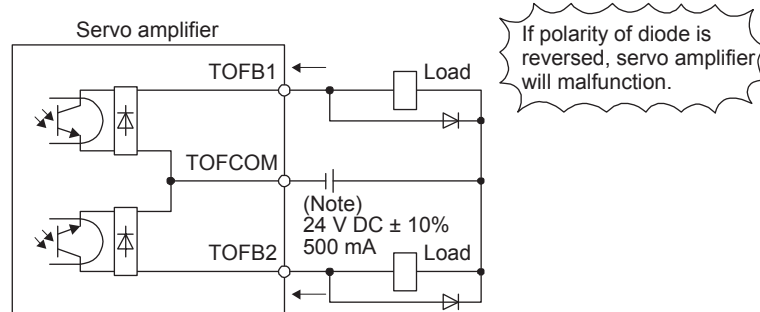

Note. If the voltage drop (maximum of 5.2 V) interferes with the relay operation, apply high voltage (maximum of 26.4 V) from external source.

(b) When outputting two STO states by using one TOFB

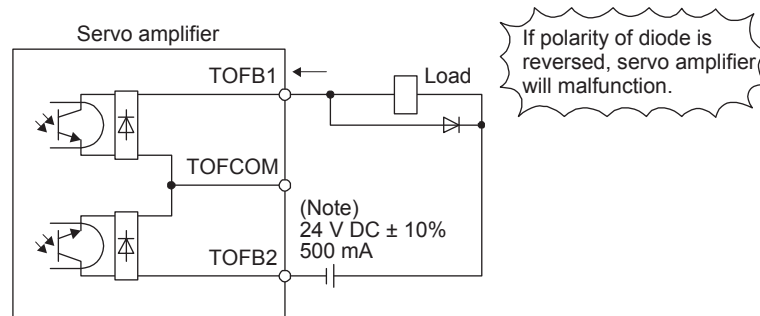

Note. If the voltage drop (maximum of 5.2 V) interferes with the relay operation, apply high voltage (maximum of 26.4 V) from external source.

13. USING STO FUNCTION

13.4.2 Source I/O interface

In this servo amplifier, source type I/O interfaces can be used. In this case, all DI-1 input signals and DO-1 output signals are of source type. Perform wiring according to the following interfaces.

(1) Digital input interface DI-1

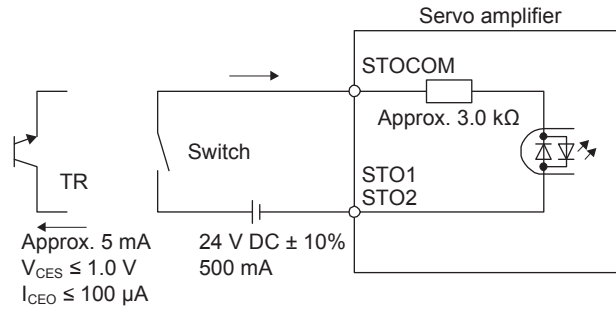

(2) Digital output interface DO-1

A maximum of 5.2 V voltage drop occurs in the servo amplifier.

(a) When outputting two STO states by using each TOFB

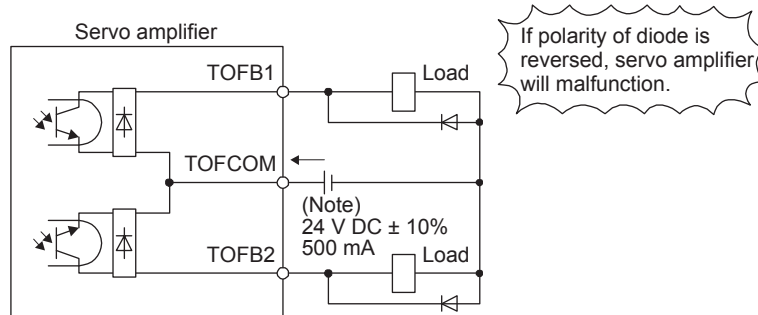

Note. If the voltage drop (maximum of 5.2 V) interferes with the relay operation, apply high voltage (maximum of 26.4 V) from external source.

(b) When outputting two STO states by using one TOFB

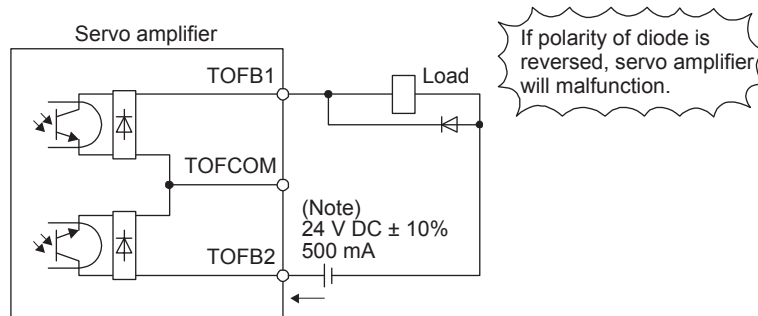

Note. If the voltage drop (maximum of 5.2 V) interferes with the relay operation, apply high voltage (maximum of 26.4 V) from external source.

APPENDIX

App. 1 Auxiliary equipment manufacturer (for reference)

Names given in the table are as of January 2012.

| Manufacturer | Reference |
|-----------------|---|
| JST | J.S.T. Mfg. Co., Ltd. |
| Junkosha | Purchase from Toa Electric Industry Co. Ltd., Nagoya Branch |
| 3M | 3M |
| Soshin Electric | Soshin Electric Co., Ltd. |
| TE Connectivity | TE Connectivity Ltd. Company |
| Molex | Molex |

App. 2 Handling of AC servo amplifier batteries for the United Nations Recommendations on the Transport of Dangerous Goods

United Nations Recommendations on the Transport of Dangerous Goods Rev. 15 (hereinafter Recommendations of the United Nations) has been issued. To reflect this, transport regulations for lithium metal batteries are partially revised in the Technical Instruction (ICAO-TI) by the International Civil Aviation Organization (ICAO) and the International Maritime Dangerous Goods Code (IMDG Code) by the International Maritime Organization (IMO).

To comply the instruction and code, we have modified the indication on the package for general-purpose AC servo batteries.

The above change will not affect the function and performance of the product.

- (1) Target model
 - (a) Battery (cell)

| Model | Option model |
|---------|---------------|
| ER6 | MR-J3BAT |
| ER17330 | MR-BAT, A6BAT |

- (b) Battery unit (assembled)

| Model | Option model |
|----------|--------------|
| ER17330 | MR-J2M-BT |
| CR17335A | MR-BAT6V1 |
| | MR-BAT6V1SET |

- (2) Purpose
 - Safer transportation of lithium metal batteries.

- (3) Change in regulations

The following points are changed for lithium metal batteries transportation by sea or air due to Recommendations of the United Nations Rev. 15 and ICAO-TI 2009-2010 edition. For lithium metal batteries, cells are classified as UN3090, and batteries contained in or packed with equipment are classified as UN3091.

- (a) A package containing 24 cells or 12 batteries or less that are not contained in equipment are no longer exempt from the following: attachment of a handling label, submission of the Shipper's Declaration for Dangerous Goods, and a 1.2 m drop test.
- (b) A battery handling label (size: 120 mm × 110 mm) is required. Emergency telephone number must be filled out in the additional handling information of the Shipper's Declaration for Dangerous Goods.

APPENDIX

(c) New handling label design containing battery illustration must be used. (only air transportation)



Figure. Example of Mitsubishi Label with Battery Illustration

(4) Action taken by Mitsubishi

The following caution will be added to the packages of the target batteries.

"Containing lithium metal battery. Regulations apply for transportation."

(5) Transportation precaution for customers

For sea or air transportation, attaching the handling label (figure) and the Shipper's Declaration for Dangerous Goods are required to the package of a Mitsubishi cell or battery. In addition, attaching them to the outer package containing several packages of Mitsubishi cells or batteries are also required. Please attach the documentations in the specified design to the packages and the outer packages.

APPENDIX

App. 3 Symbol for the new EU Battery Directive

Symbol for the new EU Battery Directive (2006/66/EC) that is plastered to general-purpose AC servo battery is explained here.



Note. This symbol mark is for EU countries only.

This symbol mark is according to the directive 2006/66/EC Article 20 Information for end-users and Annex II. Your MITSUBISHI ELECTRIC product is designed and manufactured with high quality materials and components which can be recycled and/or reused.

This symbol means that batteries and accumulators, at their end-of-life, should be disposed of separately from your household waste.

If a chemical symbol is printed beneath the symbol shown above, this chemical symbol means that the battery or accumulator contains a heavy metal at a certain concentration.

This will be indicated as follows.

Hg: mercury (0.0005%), Cd: cadmium (0.002%), Pb: lead (0.004%)

In the European Union there are separate collection systems for used batteries and accumulators. Please, dispose of batteries and accumulators correctly at your local community waste collection/recycling centre. Please, help us to conserve the environment we live in!

App. 4 Compliance with the CE marking

This servo amplifier is designed to comply with EN61800-3 and EN61800-5-1 standard.

App. 4.1 What is CE marking?

The CE marking is mandatory and must be affixed to specific products placed on the European Union. When a product conforms to the requirements, the CE marking must be affixed to the product. The CE marking also applies to machines and equipment incorporating servos.

(1) EMC directive

The EMC directive applies to the servo units alone. This servo is designed to comply with the EMC directive. The EMC directive also applies to machines and equipment incorporating servos. This requires the EMC filters to be used with machines and equipment incorporating servos to comply with the EMC directive.

(2) Low voltage directive

The low voltage directive also applies to servo units alone. This servo is designed to comply with the low voltage directive.

APPENDIX

(3) Machinery directive

The MR-J4 series servo amplifiers comply with the safety component laid down in the Machinery directive.

Do not allow using the machine until the machine in which this servo amplifier is mounted is declared to comply with the machinery directive.

App. 4.2 For compliance

Be sure to perform an appearance inspection of every unit before installation. In addition, have a final performance inspection on the entire machine/system, and keep the inspection record.

(1) Servo amplifiers and servo motors used

Use servo amplifiers and servo motors which standard product.

Servo amplifier: MR-J4-10A, MR-J4-20A, MR-J4-40A, MR-J4-60A, MR-J4-70A, MR-J4-100A, MR-J4-200A, MR-J4-350A, MR-J4-500A, MR-J4-700A

Servo motor : HG-MR_, HG-KR_, HG-SR_

(2) Structure

To comply with the CE marking, configure each equipment as follows.

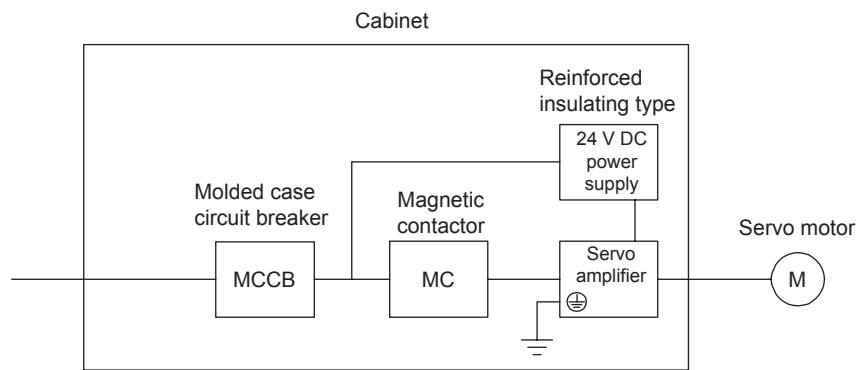

(3) Environment

(a) Operate the servo amplifier at pollution degree 2 or 1 set forth in EN 61800-5-1. For this purpose, install the servo amplifier in a cabinet which is protected against water, oil, carbon, dust, dirt, etc. (IP54).

(b) Use the equipment under the following environment.

| Item | | Environment |
|------------------------------|----------------------------------|---------------------------------------|
| (Note 1) Ambient temperature | Operation | (Note 2) 0 °C to 55 °C (non-freezing) |
| | Storage/transportation | -20 °C to 65 °C (non-freezing) |
| Ambient humidity | Operation/storage/transportation | 90% RH or less (non-condensing) |
| Altitude | Operation/storage | 1000 m or shorter |
| | Transportation | 10000 m or shorter |

Note 1. Ambient temperature is the internal temperature of the cabinet.

2. The servo amplifier of under 3.5 kW for 200 V class can be mounted closely. In this case, keep the ambient temperature within 0 °C to 45 °C or use the servo amplifier with 75% or less of the effective load ratio.

APPENDIX

(4) Power supply

- (a) This servo amplifier can be supplied from star-connected supply with earthed neutral point of overvoltage category III set forth in EN 61800-5-1. However, when you use the neutral point of 400 V system for single phase supply, a reinforced insulating transformer is required in the power input section.
- (b) The control circuit provides safe separation to the main circuit in the servo amplifier. For the interface power supply, use an external 24 V DC power supply with reinforced insulation on I/O terminals.

(5) Grounding

- (a) To prevent an electric shock, always connect the protective earth (PE) terminal (marked \oplus) of the servo amplifier to the protective earth (PE) of the cabinet.
- (b) Do not connect two grounding cables to the same protective earth (PE) terminal. Always connect cables to the terminals one-to-one.



- (c) If using a leakage circuit breaker, always ground the protective earth (PE) terminal of the servo amplifier to prevent an electric shock.

(6) Wiring

- (a) The wires to be connected to the terminal block of the servo amplifier must have crimping terminals provided with insulating tubes to prevent contact with adjacent terminals.

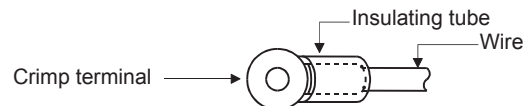

- (b) Use the servo motor-side power connector which complies with EN. The EN compliant power connector sets are available from us as options.
- (c) The servo amplifier must be installed in the metal cabinet.

(7) Peripheral devices/options

- (a) Use the molded case circuit breaker and magnetic contactor models which are EN-compliant products given in the MR-J4 Series Servo Amplifier Instruction Manual. Use a leakage current device (RCD) of type B as necessary. When it is not used, provide insulation between the servo amplifier and other device by double insulation or reinforced insulation, or install a transformer between the main power supply and the servo amplifier. Refer to App. 5 (8) for molded case circuit breakers and fuses.
- (b) The sizes of the wires given in the MR-J4 Series Servo Amplifier Instruction Manual meet the following conditions. For use in any other conditions, follow table 6 and Annex D of EN 60204-1.
 - Ambient temperature: 40 °C
 - Insulator: PVC (polyvinyl chloride)
 - Route the wires on wall surface or open cable tray.
- (c) Use shielded wires for I/O power wires.
- (d) Use EMC filters of HF3000A-UN series manufactured by Soshin Electric.

APPENDIX

(e) Use the surge protector of RSPD-250-U4 manufactured by Okaya Electric Industries.

(8) Performing EMC tests

When EMC tests are run on a machine and device into which the servo amplifier has been installed, it must conform to the electromagnetic compatibility (immunity/emission) standards after it has satisfied the operating environment/electrical equipment specifications.

For EMC directive conforming methods about servo amplifiers, refer to the EMC Installation Guidelines (IB(NA)67310).

(9) Short Circuit Current Rating (SCCR)

We confirmed in the short-circuit test that this servo amplifier is suitable for use in a circuit rated at 100 kA RMS or less, and maximum voltage 500 V.

(10) Configuration diagram

Refer to App. 5 (9) for configuration diagram.

App. 5 Compliance with UL/CSA standard

This servo amplifier is designed to comply with UL 508C and CSA C22.2 No.14 standard.

For the situation of safety certification, contact your local sales office.

(1) Servo amplifiers and servo motors used

Use servo amplifiers and servo motors which standard product.

| Servo amplifier | Servo motor | | |
|-----------------|-------------|--------|-----------------|
| | HG-MR | HG-KR | HG-SR |
| MR-J4-10A | 053/13 | 053/13 | |
| MR-J4-20A | 23 | 23 | |
| MR-J4-40A | 43 | 43 | |
| MR-J4-60A | | | 51/52 |
| MR-J4-70A | 73 | 73 | |
| MR-J4-100A | | | 81/102 |
| MR-J4-200A | | | 121/152/201/202 |
| MR-J4-350A | | | 301/352 |
| MR-J4-500A | | | 421/502 |
| MR-J4-700A | | | 702 |

APPENDIX

(2) Installation

The MR-J4 series have been approved as the products which have been installed in a cabinet. The minimum cabinet size is based on 150% of each MR-J4 combination. And also, design the cabinet so that the ambient temperature in the cabinet is 55 °C or less.

The servo amplifier must be installed in the metal cabinet.

To ensure safety, do not touch the charging section for 15 minutes after power-off.

| Item | | Environment |
|------------------------------|----------------------------------|---------------------------------------|
| (Note 1) Ambient temperature | Operation | (Note 2) 0 °C to 55 °C (non-freezing) |
| | Storage/transportation | -20 °C to 65 °C (non-freezing) |
| Ambient humidity | Operation/storage/transportation | 90% RH or less (non-condensing) |
| Altitude | Operation/storage | 1000 m or shorter |
| | Transportation | 10000 m or shorter |

Note 1. Ambient temperature is the internal temperature of the cabinet.

2. The servo amplifier of under 3.5 kW for 200 V class can be mounted closely. In this case, keep the ambient temperature within 0 °C to 45 °C or use the servo amplifier with 75% or less of the effective load ratio.

(3) Short Circuit Current Rating (SCCR)

We confirmed in the short-circuit test that this servo amplifier is suitable for use in a circuit rated at 100 kA RMS or less, and maximum voltage 500 V.

(4) Overload protection characteristics

Servo amplifier MR-J4 series has solid-state servo motor overload protection. (It is set on the basis (full load current) of 120% rated current of the servo amplifier.)

(5) Selection example of wires

To comply with the UL/CSA standard, use UL-approved copper wires rated at 75 °C for wiring.

The following table shows the wire sizes [AWG] and the crimping terminal symbols rated at 75 °C.

| Servo amplifier | (Note 2) Wires [AWG] | | | |
|--|----------------------|---------|--------|----------|
| | L1/L2/L3/⊕ | L11/L21 | P+/C/D | U/V/W |
| MR-J4-10A/MR-J4-20A/ MR-J4-40A/MR-J4-60A/ MR-J4-70A/MR-J4-100A | 14 | 14 | 14 | (Note 3) |
| MR-J4-200A | 12 | | | |
| MR-J4-350A | 10 | | | |
| (Note 1) MR-J4-500A | 8: a | 14: c | 14: c | |
| (Note 1) MR-J4-700A | 8: b | | 12: a | |

Note 1. To connect these models to a terminal block, be sure to use the screws that come with the terminal block.

2. Alphabets in the table indicate crimping tools. Refer to the following table for the crimping terminals and crimping tools.

3. The wire size depends on the servo motor characteristics.

APPENDIX

Table: Recommended crimp terminals

| Symbol | Servo amplifier-side crimp terminals | | Manufacturer |
|---------------|--------------------------------------|-----------------|--------------|
| | (Note 2) Crimp terminals | Applicable tool | |
| a | FVD5.5-4 | YNT-1210S | JST |
| (Note 1) b | 8-4NS | YHT-8S | |
| c | FVD2-4 | YNT-1614 | |

- Note 1. Coat the crimping part with an insulation tube.
 Note 2. Always use recommended crimp terminals or equivalent since some crimp terminals cannot be installed depending on the size.

(6) Tightening torque of each terminal

| Servo amplifier | Tightening torque [N•m] | | | | | | | | | | | | | |
|--|-------------------------|----|----|----|----|----|----|-----|---|-----|-----|---|---|---|
| | L1 | L2 | L3 | N- | P3 | P4 | P+ | C | D | L11 | L21 | U | V | W |
| MR-J4-10A/MR-J4-20A/ MR-J4-40A/MR-J4-60A/ MR-J4-70A/MR-J4-100A/ MR-J4-200A/MR-J4-350A | 1.2 | | | | | | | | | | | | | |
| MR-J4-500A | 1.2 | | | | | | | 0.8 | | 1.2 | | | | |
| MR-J4-700A | 1.2 | | | | | | | 0.8 | | 1.2 | | | | |

(7) About wiring protection

For installation in United States, branch circuit protection must be provided, in accordance with the National Electrical Code and any applicable local codes.

For installation in Canada, branch circuit protection must be provided, in accordance with the Canada Electrical Code and any applicable provincial codes.

(8) Options and peripheral devices

Use the UL/CSA standard-compliant products.

Use the molded case circuit breaker (UL489 Listed MCCB) or a Class T fuse indicated in the table below.

| Servo amplifier | Molded case circuit breaker | | Fuse | |
|-----------------|-----------------------------|----------------|-------------|----------------|
| | Current | Voltage AC [V] | Current [A] | Voltage AC [V] |
| MR-J4-10A | 50 A frame 5 A | 240 | 10 | 300 |
| MR-J4-20A | | | | |
| MR-J4-40A | | | | |
| MR-J4-60A | | | | |
| MR-J4-70A | 50 A frame 10 A | | 15 | |
| MR-J4-100A | 50 A frame 20 A | | 40 | |
| MR-J4-200A | 50 A frame 30 A | | 60 | |
| MR-J4-350A | 50 A frame 40 A | | 80 | |
| MR-J4-500A | 50 A frame 50 A | 100 | | |

APPENDIX

(9) Configuration diagram

Representative configuration diagram example to conform to the UL/CSA standard is shown below. The grounding wiring is excluded from the figure configuration.

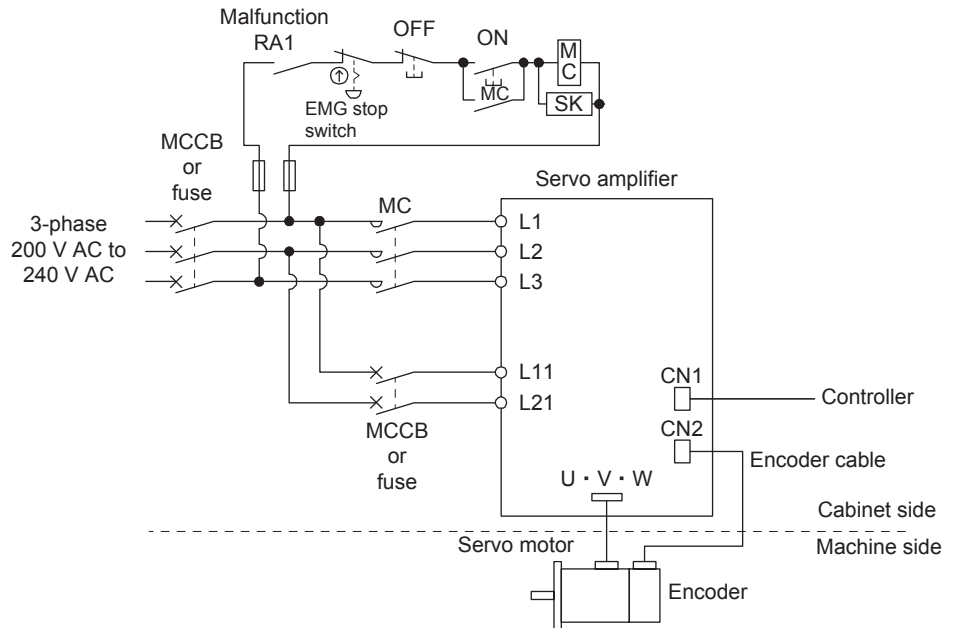

(10) Power supply

The control circuit provides safe separation to the main circuit in the servo amplifier.

| | Connector/terminal |
|-----------------|--------------------------------|
| Main circuit | CNP1/CNP2/CNP3/TE1/TE2/TE3/TE4 |
| Control circuit | CN1/CN2/CN3/CN4/CN5/CN8 |

(11) UL/CSA standard certification mark on products

The following mark shows UL/CSA standard certification of MR-J4 multi-axis servo amplifiers.

| Mark | Certification Body | Remarks |
|------|---|-----------------------------|
| | TUV Rheinland of North America Inc. Independent public testing institution in North America National recognized testing laboratory (NRTL) | NRTL listing mark (UL 508C) |

App. 6 Compliance with KC mark

For the situation of compliance, contact your local sales office.

When you use the products in South Korea, note the following.

이 기기는 업무용 (A 급) 전자파적합기기로서 판 매자 또는 사용자는 이 점을 주의하시기 바라며, 가정외의 지역에서 사용하는 것을 목적으로 합니다.

(The product is for business use (Class A) and meets the electromagnetic compatibility requirements. The seller and the user must note the above point, and use the product in a place except for home.)

APPENDIX

App. 7 MR-J3-D05 Safety logic unit

App. 7.1 Contents of the package

Open packing, and confirm the content of packing.

| Contents | Quantity |
|--|----------|
| MR-J3-D05 Safety logic unit | 1 |
| Connector for CN9 1-1871940-4 (TE Connectivity) | 1 |
| Connector for CN10 1-1871940-8 (TE Connectivity) | 1 |
| MR-J3-D05 Installation Guide | 1 |

App. 7.2 Terms related to safety

App. 7.2.1 Stop function for IEC/EN 61800-5-2

(1) STO function (Refer to IEC/EN 61800-5-2: 2007 4.2.2.2 STO.)

This function is integrated into the MR-J4 series servo amplifiers.

The STO function shuts down energy to servo motors, thus removing torque. This function electronically cuts off power supply in servo amplifiers for MR-J4 series servo amplifiers.

The purpose of this safety function is as follows.

- 1) Uncontrolled stop according to stop category 0 of IEC/EN 60204-1
- 2) Preventing unexpected start-up

(2) SS1 function (Refer to IEC 61800-5-2: 2007 4.2.2.3C Safe stop 1 temporal delay.)

SS1 is a function which initiates the STO function when the previously set delay time has passed after the servo motor starts decelerating. The delay time can be set with MR-J3-D05 safety logic unit.

The purpose of this safety function is as follows. This function is available by using a MR-J4 series servo amplifier with MR-J3-D05.

- Controlled stop according to stop category 1 of IEC/EN 60204-1

App. 7.2.2 Emergency operation for IEC/EN 60204-1

(1) Emergency stop (Refer to IEC/EN 60204-1: 2005 9.2.5.4.2 Emergency Stop.)

Emergency stop must override all other functions and actuation in all operation modes. Power to the machine driving part which may cause a hazardous state must be either removed immediately (stop category 0) or must be controlled to stop such hazardous state as soon as possible (stop category 1). Restart must not be allowed even after the cause of the emergency state has been removed.

(2) Emergency switching off (Refer to IEC/EN 60204-1: 2005 9.2.5.4.3 Emergency Switching OFF.)

Removal of input power to driving device to remove electrical risk and to meet above mentioned safety standards.

APPENDIX

App. 7.3 Cautions

The following basic safety notes must be read carefully and fully in order to prevent injury to persons or damage to property.

Only qualified personnel are authorized to install, start-up, repair or service the machines in which these components are installed.

They must be familiar with all applicable local safety regulations and laws in which machines with these components are installed, particularly the standards and guidelines mentioned in this Instruction Manual and the requirements mentioned in ISO/EN ISO 13849-1, IEC/EN 61508, IEC/EN 61800-5-2, and IEC/EN 60204-1.

The staff responsible for this work must be given express permission from the company to perform start-up, programming, configuration, and maintenance of the machine in accordance with the safety standards.

| | | |
|---|----------------|---|
|  | WARNING | ● Improper installation of the safety related components or systems may cause improper operation in which safety is not assured, and may result in severe injuries or even death. |
|---|----------------|---|

Protective Measures

- As described in IEC/EN 61800-5-2, the Safe Torque Off (STO) function only prevents the servo amplifier from supplying energy to the servo motor. Therefore, if an external force acts upon the drive axis, additional safety measures, such as brakes or counter-weights must be used.

App. 7.4 Residual risk

Machine manufacturers are responsible for all risk evaluations and all associated residual risks. Below are residual risks associated with the STO/EMG function. Mitsubishi is not liable for any damages or injuries caused by the residual risks.

- (1) The SS1 function only guarantees the delay time before STO/EMG is engaged. Proper setting of this delay time is the full responsibility of the company and/or individuals responsible for installation and commissioning of the safety related system. The system, as a whole, must pass safety standards certification.
- (2) When the SS1 delay time is shorter than the required servo motor deceleration time, if the forced stop function is malfunctioning, or if STO/EMG is engaged while the servo motor is still rotating; the servo motor will stop with the dynamic brake or freewheeling.
- (3) For proper installation, wiring, and adjustment, thoroughly read the manual of each individual safety related component.
- (4) Be sure that all safety related switches, relays, sensors, etc., meet the required safety standards. The Mitsubishi Electric safety related components mentioned in this manual are certified by Certification Body as meeting the requirements of ISO/EN ISO 13849-1 Category 3, PL d and IEC/EN 61508 SIL 2.
- (5) Safety is not assured until safety-related components of the system are completely installed or adjusted.
- (6) When replacing a servo amplifier etc. or MR-J3-D05 safety logic unit, confirm that the new equipment is exactly the same as those being replaced. Once installed, be sure to verify the performance of the safety functions before commissioning the system.

APPENDIX

- (7) Perform all risk assessments and safety level certification to the machine or the system as a whole. It is recommended that a Certification Body final safety certification of the system be used.
- (8) To prevent accumulation of multiple malfunctions, perform a malfunction check at regular intervals as deemed necessary by the applicable safety standard. Regardless of the system safety level, malfunction checks should be performed at least once per year.
- (9) If the upper and lower power module in the servo amplifier are shorted and damaged simultaneously, the servo motor may make a half revolution at a maximum.

App. 7.5 Block diagram and timing chart

(1) Function block diagram

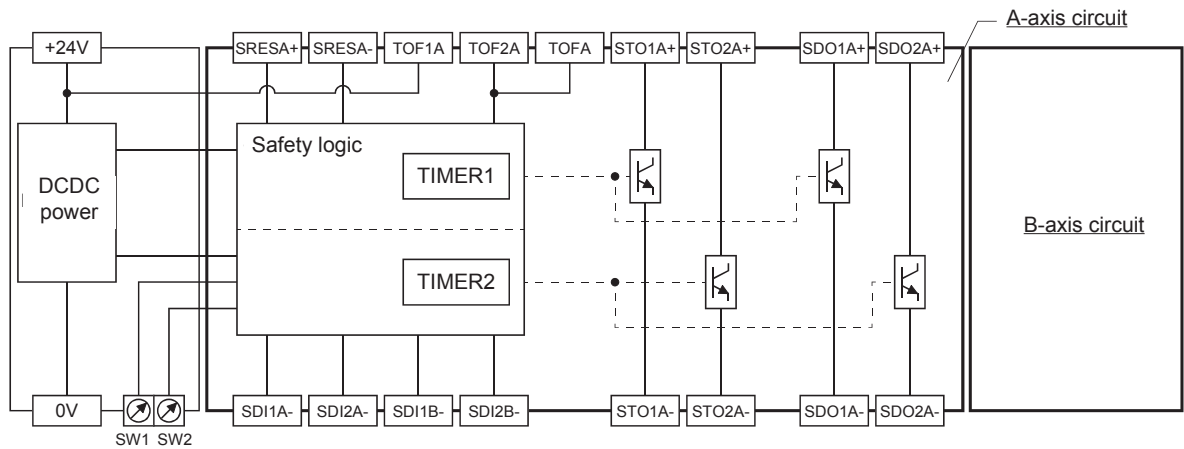

(2) Operation sequence

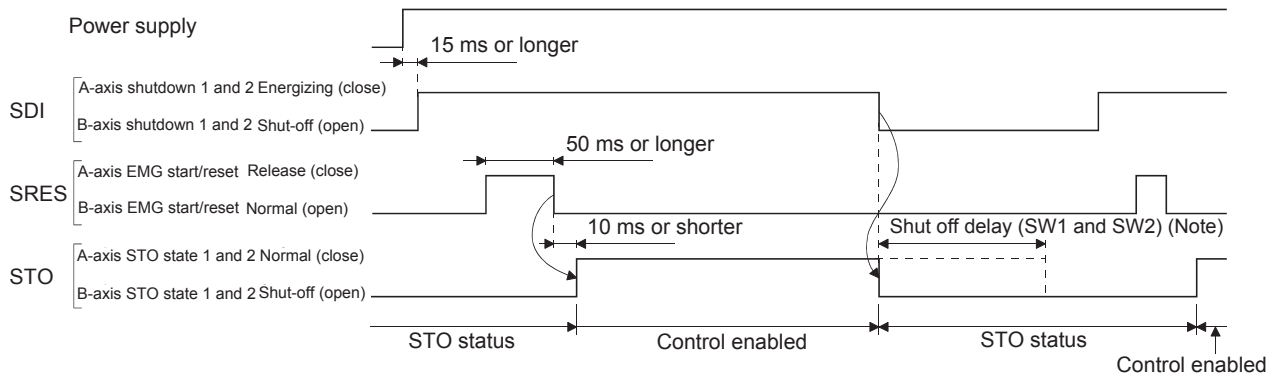

Note. Refer to App. 7.10.

APPENDIX

App. 7.6 Maintenance and disposal

MR-J3-D05 safety logic unit is equipped with LED displays to check errors for maintenance.
Please dispose this unit according to your local laws and regulations.

App. 7.7 Functions and configuration

App. 7.7.1 Introduction

The safety logic unit MR-J3-D05 has two systems in which the each system has SS1 function (delay time) and output of STO function.

APPENDIX

App. 7.7.2 Specifications

| | | |
|------------------------------|--|---|
| Safety logic unit model | | MR-J3-D05 |
| Control circuit power supply | Voltage | 24 V DC |
| | Permissible voltage fluctuation | 24 V DC \pm 10% |
| | Power supply capacity [A] | 0.5 (Note 1, 2) |
| Compatible system | | 2 systems (A-axis, B-axis independent) |
| Shut-off input | | 4 points (2 point \times 2 systems) SDI_ <u> </u> : (source/sink compatible) (Note 3) |
| Shut-off release input | | 2 points (1 point \times 2 systems) SRES_ <u> </u> : (source/sink compatible) (Note 3) |
| Feedback input | | 2 points (1 point \times 2 systems) TOF_ <u> </u> : (source compatible) (Note 3) |
| Input type | | Photocoupler insulation, 24 V DC (external supply), internal limited resistance 5.4 k Ω |
| Shut-off output | | 8 points (4 point \times 2 systems) STO_ <u> </u> : (source compatible) (Note 3) SDO_ <u> </u> : (source/sink compatible) (Note 3) |
| Output type | | Photocoupler insulation, open-collector type Permissible current: 40 mA/1 output, Inrush current: 100 mA/1 output |
| Delay time setting | | A-axis: Select from 0 s, 1.4 s, 2.8 s, 5.6 s, 9.8 s, or 30.8 s. B-axis: Select from 0 s, 1.4 s, 2.8 s, 9.8 s, or 30.8 s. Accuracy: \pm 2% |
| Safety function | | STO, SS1 (IEC/EN 61800-5-2) EMG STOP, EMG OFF IEC/EN 60204-1) |
| Safety performance | Standards certified by CB | EN ISO 13849-1 category 3 PL d, EN 61508 SIL 2, EN 62061 SIL CL 2, and EN 61800-5-2 SIL 2 |
| | Response performance (when delay time is set to 0s) | 10 ms or less (STO input off \rightarrow shut-off output off) |
| | Test pulse input (STO) (Note 4) | Test pulse interval: 1 Hz to 25 Hz Test pulse off time: Up to 1 ms |
| | Mean time to dangerous failure (MTTFd) | 516 years |
| | Diagnosis converge (DC avg) | 93.1% |
| | Average probability of dangerous failures per hour (PFH) | 4.75×10^{-9} [1/h] |
| Compliance to standards | CE marking | LVD: EN 61800-5-1 EMC: EN 61800-3 MD: EN ISO 13849-1, EN 61800-5-2, EN 62061 |
| Structure | | Natural-cooling, open (IP rating: IP 00) |
| Environment | Ambient temperature | 0 °C to 55 °C (non-freezing), storage: -20 °C to 65 °C (non-freezing) |
| | Ambient humidity | 90% RH or less (non-condensing), storage: 90% RH or less (non-condensing) |
| | Ambience | Indoors (no direct sunlight), free from corrosive gas, flammable gas, oil mist, dust, and dirt |
| | Altitude | Max. 1000 m above sea level |
| | Vibration | 5.9 m/s ² or less at 10 Hz to 55 Hz (directions of X, Y, and Z axes) |
| Mass | [kg] | 0.2 (including CN9 and CN10 connectors) |

- Note
1. Inrush current of approximately 1.5 A flows instantaneously when turning the control circuit power supply on. Select an appropriate capacity of power supply considering the inrush current.
 2. Power-on duration of the safety logic unit is 100,000 times.
 3. : in signal name indicates a number or axis name.
This function diagnoses malfunction of contacts including an external circuit by shortly turning off signals from a controller to the servo amplifier at a constant period while input signals of the servo amplifier are on.

APPENDIX

App. 7.7.3 When using MR-J3-D05 with a MR-J4 series servo amplifier

(1) System configuration diagram

| |
|---|
| POINT |
| ●The STO cable (MR-D05UDL-M) for MR-J3 series is not available. |

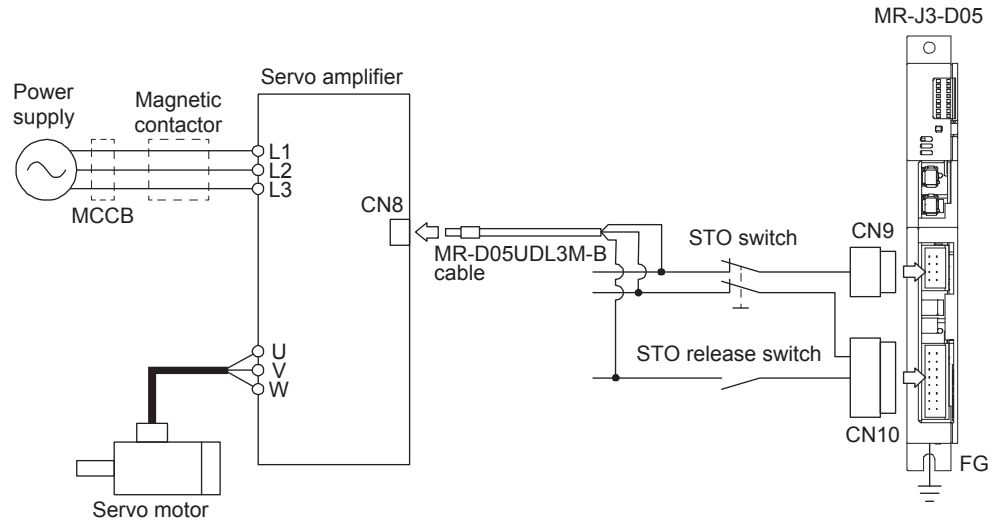

APPENDIX

(2) Connection example

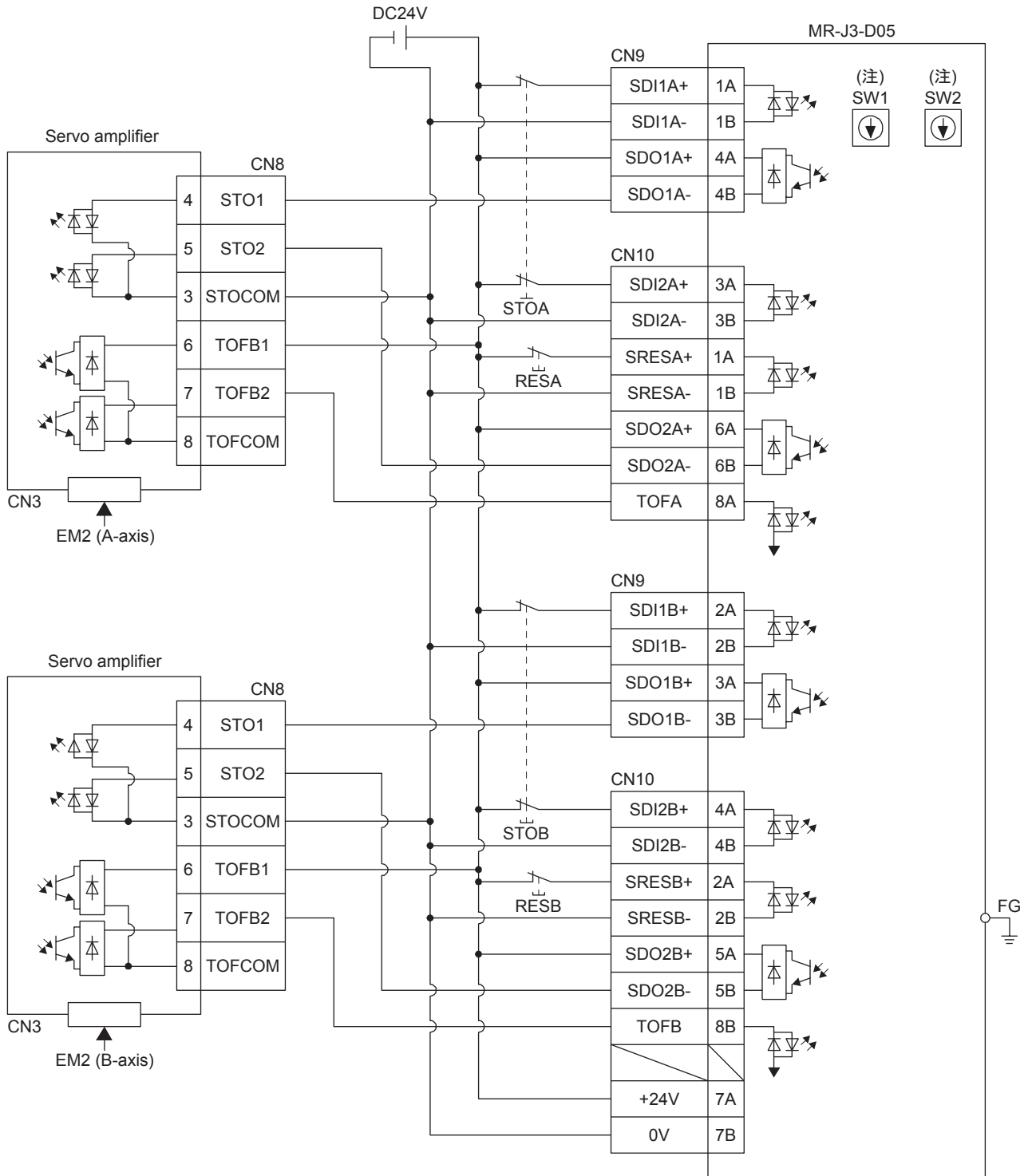

Note. Set the delay time of STO output with SW1 and SW2. These switches are located where denoted from the front panel.

APPENDIX

(3) Description of signal and function

The following table lists which operation, the forced stop deceleration or the dynamic brake, will function for each signal input or power-off.

| Input signal to MR-J4 series servo amplifier | Signal logic | Description | Forced stop deceleration ○: operates ×: does not operate | Remarks |
|---|-------------------------------|-----------------------------|--|--|
| EM2 | Normally closed contact opens | Decelerating to stop signal | ○ | Unlike the decelerating to stop signal, RES and SON are prioritized. |
| STO1 | Normally closed contact opens | STO1 shut-off signal | - | |
| STO2 | Normally closed contact opens | STO2 shut-off signal | - | |
| LSP | Normally closed contact opens | Stroke end + | ○ | |
| LSN | Normally closed contact opens | Stroke end - | ○ | |
| Reset command | Normally open contact closes | Alarm reset | - | |
| Servo-on command | Normally open contact opens | Servo-off | - | |
| Servo amplifier control circuit power supply shut-off | | | × | Decelerating to stop starts with dynamic brake after control circuit power supply shut-off is detected. |
| Servo amplifier main circuit power supply shut-off | | | ○ | Deceleration to stop starts at the detection voltage of [AL. 10 Undervoltage], and the dynamic brake starts at 80% of the detection voltage. |

(4) Basic operation example

The following shows when you use MR-J3-D05 with a MR-J4 series servo amplifier.

The switching of STOA is output to CN8A and usually is input to the MR-J4 series servo amplifier.

The switching of STOB is output to CN8B and usually is input to the MR-J4 series servo amplifier.

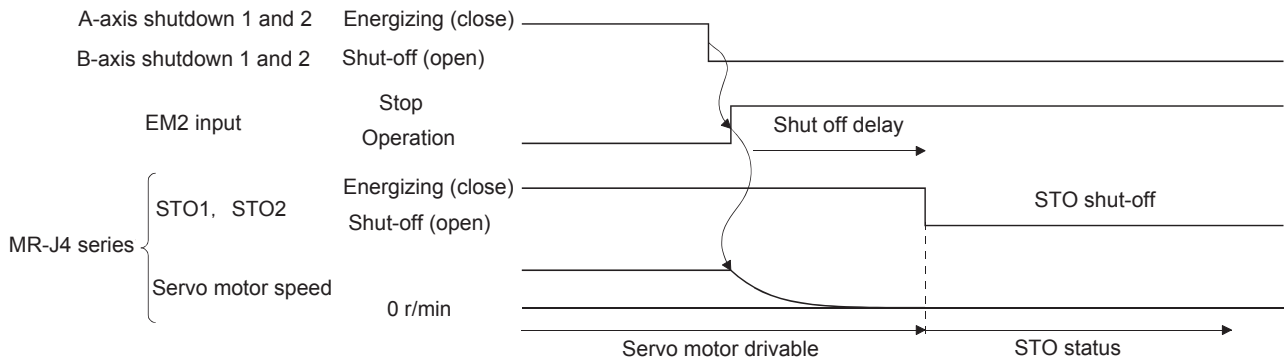

APPENDIX

App. 7.8 Signal

App. 7.8.1 Connector/pin assignment

(1) CN8A

| Device | Symbol | Pin No. | Function/application | (Note) I/O |
|------------------|------------------|---------|--|---------------|
| A-axis STO1 | STO1A- STO1A+ | 4 | Outputs STO1 to A-axis driving device. | O |
| | | 1 | Outputs the same signal as A-axis STO2. STO state (base shutdown): Between STO1A+ and STO1A- is opened. STO release state (in driving): Between STO1A+ and STO1A- is closed. | |
| A-axis STO2 | STO2A- STO2A+ | 5 | Outputs STO2 to A-axis driving device. | O |
| | | 6 | Outputs the same signal as A-axis STO1. STO state (base shutdown): Between STO2A+ and STO2A- is opened. STO release state (in driving): Between STO2A+ and STO2A- is closed. | |
| A-axis STO state | TOF2A TOF1A | 7 | Inputs STO state of A-axis driving device. | I |
| | | 8 | STO state (base shutdown): Open between TOF2A and TOF1A. STO release state (in driving): Close between TOF2A and TOF1A. | |

Note. Exclusive interface for MR-J4 series servo amplifiers.

(2) CN8B

| Device | Symbol | Pin No. | Function/application | (Note) I/O |
|------------------|------------------|---------|--|---------------|
| B-axis STO1 | STO1B- STO1B+ | 1 | Outputs STO1 to B-axis driving device. | O |
| | | 4 | Outputs the same signal as B-axis STO2. STO state (base shutdown): Between STO1B+ and STO1B- is opened. STO release state (in driving): Between STO1B+ and STO1B- is closed. | |
| B-axis STO2 | STO2B- STO2B+ | 5 | Outputs STO2 to B-axis driving device. | O |
| | | 6 | Outputs the same signal as B-axis STO1. STO state (base shutdown): Between STO2B+ and STO2B- is opened. STO release state (in driving): Between STO2B+ and STO2B- is closed. | |
| B-axis STO state | TOF2B TOF1B | 7 | Inputs STO state of B-axis driving device. | I |
| | | 8 | STO state (base shutdown): Open between TOF2B and TOF1B. STO release state (in driving): Close between TOF2B and TOF1B. | |

Note. Exclusive interface for MR-J4 series servo amplifiers.

(3) CN9

| Device | Symbol | Pin No. | Function/application | I/O division |
|-------------------|------------------|---------|--|-----------------|
| A-axis shutdown 1 | SDI1A+ SDI1A- | 1A | Connect this device to a safety switch for A-axis driving device. | DI-1 |
| | | 1B | Input the same signal as A-axis shutdown 2. STO state (base shutdown): Open between SDI1A+ and SDI1A-. STO release state (in driving): Close between SDI1A+ and SDI1A-. | |
| B-axis shutdown 1 | SDI1B+ SDI1B- | 2A | Connect this device to a safety switch for B-axis driving device. | DI-1 |
| | | 2B | Input the same signal as B-axis shutdown 2. STO state (base shutdown): Open between SDI1B+ and SDI1B-. STO release state (in driving): Close between SDI1B+ and SDI1B-. | |
| A-axis SDO1 | SDO1A+ SDO1A- | 4A | Outputs STO1 to A-axis driving device. | DO-1 |
| | | 4B | Outputs the same signal as A-axis SDO2. STO state (base shutdown): Between SDO1A+ and SDO1A- is opened. STO release state (in driving): Between SDO1A+ and SDO1A- is closed. | |
| B-axis SDO1 | SDO1B+ SDO1B- | 3A | Outputs STO1 to B-axis driving device. | DO-1 |
| | | 3B | Outputs the same signal as B-axis SDO2. STO state (base shutdown): Between SDO1B+ and SDO1B- is opened. STO release state (in driving): Between SDO1B+ and SDO1B- is closed. | |

APPENDIX

(4) CN10

| Device | Symbol | Pin No. | Function/application | I/O division |
|------------------------------|------------------|----------|--|--------------|
| A-axis shutdown 2 | SDI2A+ SDI2A- | 3A 3B | Connect this device to a safety switch for A-axis driving device. Input the same signal as A-axis shutdown 1. STO state (base shutdown): Open between SDI2A+ and SDI2A-. STO release state (in driving): Close between SDI2A+ and SDI2A-. | DI-1 |
| B-axis shutdown 2 | SDI2B+ SDI2B- | 4A 4B | Connect this device to a safety switch for B-axis driving device. Input the same signal as B-axis shutdown 1. STO state (base shutdown): Open between SDI2B+ and SDI2B-. STO release state (in driving): Close between SDI2B+ and SDI2B-. | DI-1 |
| A-axis EMG start/reset | SRESA+ SRESA- | 1A 1B | Signal for releasing STO state (base shutdown) on A-axis driving device. Releases STO state (base shutdown) on A-axis driving device by switching between SRESA+ and SRESA- from on (connected) to off (opened). | DI-1 |
| B-axis EMG start/reset | SRESB+ SRESB- | 2A 2B | Signal for releasing STO state (base shutdown) on B-axis driving device. Releases STO state (base shutdown) on B-axis driving device by switching between SRESB+ and SRESB- from on (connected) to off (opened). | DI-1 |
| A-axis SDO2 | SDO2A+ SDO2A- | 6A 6B | Outputs STO2 to A-axis driving device. Outputs the same signal as A-axis STO1. STO state (base shutdown): Between SDO2A+ and SDO2A- is opened. STO release state (in driving): Between SDO2A+ and SDO2A- is closed. | DO-1 |
| B-axis SDO2 | SDO2B+ SDO2B- | 5A 5B | Outputs STO2 to B-axis driving device. Outputs the same signal as B-axis SDO1. STO state (base shutdown): Between SDO2B+ and SDO2B- is opened. STO release state (in driving): Between SDO2B+ and SDO2B- is closed. | DO-1 |
| Control circuit power supply | +24V | 7A | Connect + side of 24 V DC. | |
| Control circuit power GND | 0V | 7B | Connect - side of 24 V DC. | |
| A-axis STO state | TOFA | 8A | TOFA is internally connected with TOF2A. | |
| B-axis STO state | TOFB | 8B | TOFB is internally connected with TOF2B. | |

App. 7.8.2 Interfaces

(1) Sink I/O interface (CN9, CN10 connector)

(a) Digital input interface DI-1

Turn on/off the input signal with a relay or open-collector transistor.

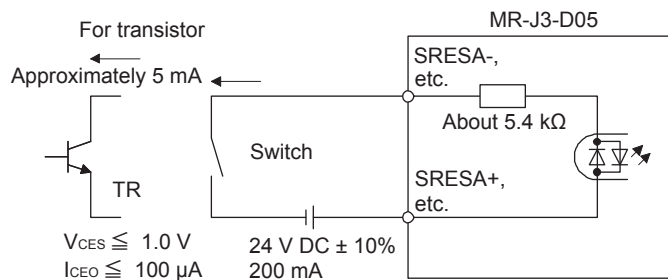

APPENDIX

(b) Digital output interface DO-1

A lamp, relay or photocoupler can be driven. Install a diode (D) for an inductive load, or install an inrush current suppressing resistor (R) for a lamp load. (Rated current: 40 mA or less, maximum current: 50 mA or less, inrush current: 100 mA or less) A maximum of 2.6 V voltage drop occurs in the MR-J3-D05.

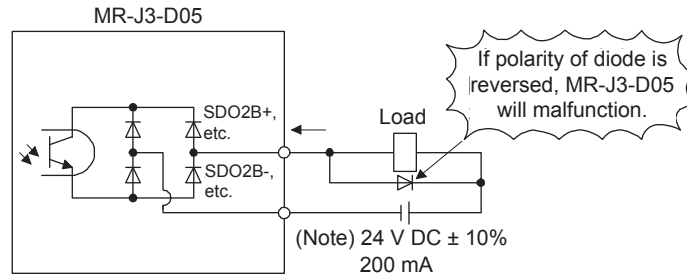

Note. If the voltage drop (maximum of 2.6 V) interferes with the relay operation, apply high voltage (maximum of 26.4 V) from external source.

(2) Source I/O interfaces (CN9, CN10 connector)

In this servo amplifier, source type I/O interfaces can be used. In this case, all DI-1 input signals and DO-1 output signals are of source type. Perform wiring according to the following interfaces.

(a) Digital input interface DI-1

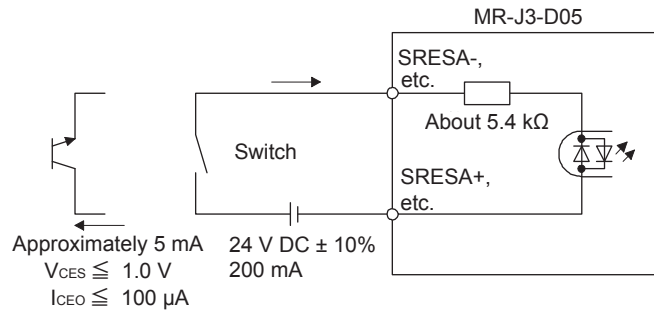

(b) Digital output interface DO-1

A maximum of 2.6 V voltage drop occurs in the servo amplifier.

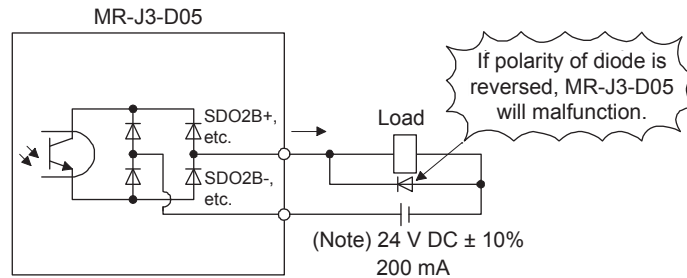

Note. If the voltage drop (maximum of 2.6 V) interferes with the relay operation, apply high voltage (maximum of 26.4 V) from external source.

APPENDIX

App. 7.8.3 Wiring CN9 and CN10 connectors

Handle with the tool with care when connecting wires.

(1) Wire strip

- (a) Use wires with size of AWG 24 to 20 (0.22 mm^2 to 0.5 mm^2) (recommended electric wire: UL1007) and strip the wires to make the stripped length $7.0 \text{ mm} \pm 0.3 \text{ mm}$. Confirm the stripped length with gauge, etc. before using the wires.
- (b) If the stripped wires are bent, feazed or too thick due to twisting too much, fix the wires by twisting lightly, etc. Then, confirm the stripped length before using the wires. Do not use excessively deformed wires.
- (c) Smooth out the wire surface and stripped insulator surface.

(2) Connecting wires

Before connecting wires, be sure to pull out the receptacle assembly from the header connector. If wires are connected with inserted connector, the connector and the printed board may malfunction.

(a) Using extraction tool (1891348-1 or 2040798-1)

1) Dimensions and mass

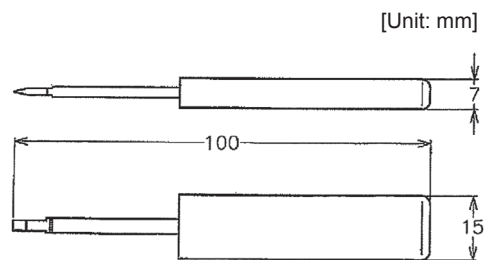

Mass : Approx. 20 g

APPENDIX

2) Connecting wires

- a) Confirm the model number of the housing, contact and tool to be used.
- b) Insert the tool diagonally into the receptacle assembly.

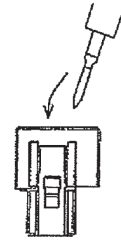

- c) Insert the tool until it hits the surface of the receptacle assembly. At this stage, the tool is vertical to the receptacle assembly.

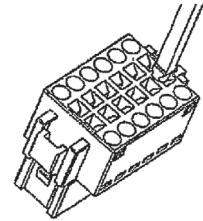

- d) Insert wires in the wiring hole till the end. The wires should be slightly twisted in advance to prevent it from being feazed.

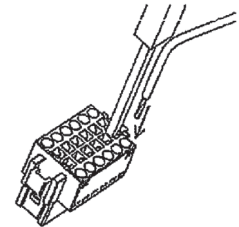

It is easy to insert the wire if the wire is inserted diagonally while twisting the tool.

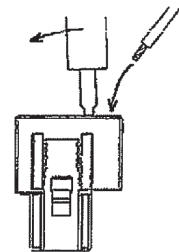

- e) Remove the tool.

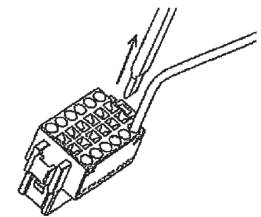

APPENDIX

(b) Using a screwdriver

To avoid damaging housings and springs when wiring with screwdriver, do not put excessive force. Be cautious when connecting.

1) Adjusting screw driver

Diameter: 2.3 mm \pm 0.05 mm
Length: 120 mm or less
Width: 2.3 mm, Blade thickness: 0.25 mm
Angle in tip of the blade: 18 ± 1 degrees

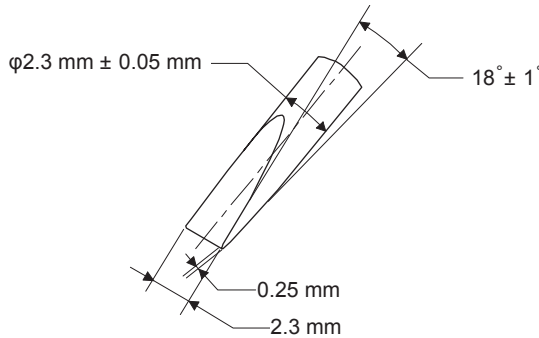

Screwdriver diameter: ϕ 2.3 mm

Diameter: 2.5 mm \pm 0.05 mm
Length: 120 mm or less
Width: 2.5 mm, Blade thickness: 0.3 mm
Angle in tip of the blade: 12 ± 1 degrees

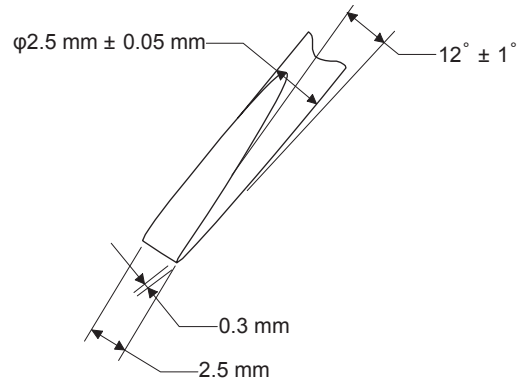

Screwdriver diameter: ϕ 2.5 mm

2) Connecting wires

- a) Insert a screwdriver in the front slot a little diagonally, and depress the spring. While depressing the spring, insert the wires until they hit the end. Note that the housing and spring may be damaged if the screwdriver is inserted strongly. Never insert the screwdriver in the wire hole. Otherwise, the connector will be damaged.
- b) Pull the screwdriver out while pressing the wires. Connecting wires is completed.
- c) Pull the wire lightly to confirm that the wire is surely connected.
- d) To remove the wires, depress the spring by the screwdriver in the same way as connecting wires, and then pull the wires out.

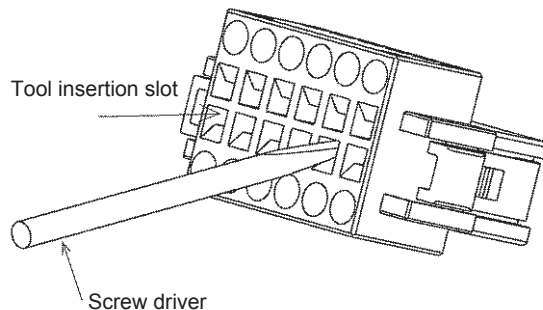

APPENDIX

(3) Connector insertion

Insert the connector all the way straight until you hear or feel clicking. When removing the connector, depress the lock part completely before pulling out. If the connector is pulled out without depressing the lock part completely, the housing, contact and/or wires may be damaged.

(4) Compatible wire

Compatible wire size is listed below.

| Wire size | |
|-----------------|-----|
| mm ² | AWG |
| 0.22 | 24 |
| 0.34 | 22 |
| 0.50 | 20 |

(5) Others

(a) Fix a wire tie at least distance of "A" × 1.5 away from the end of the connector.

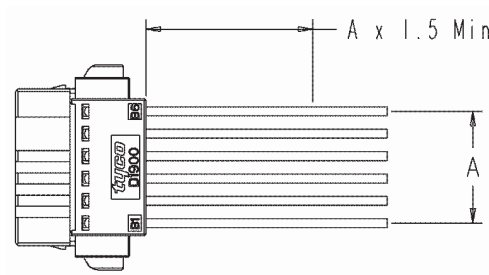

(b) Be sure that wires are not pulled excessively when the connector is inserted.

App. 7.8.4 Wiring FG

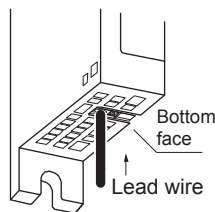

Wire range

Single wire: ϕ 0.4 mm to 1.2 mm (AWG 26 to AWG 16)

Stranded wire: 0.2 mm² to 1.25 mm² (AWG 24 to AWG 16),
wire ϕ 0.18 mm or more

APPENDIX

App. 7.9 LED display

I/O status, malfunction and power on/off are displayed with LED for each A-axis and B-axis.

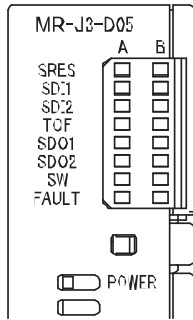

| LED | Description | LED | |
|-------|---|----------|----------|
| | | Column A | Column B |
| SRES | Monitor LED for start/reset Off: The start/reset is off. (The switch contact is opened.) On: The start/reset is on. (The switch contact is closed.) | A-axis | B-axis |
| SD11 | Monitor LED for shut-off 1 Off: The shut-off 1 is off. (The switch contact is closed.) On: The shut-off 1 is on. (The switch contact is opened.) | | |
| SD12 | Monitor LED for shut-off 2 Off: The shut-off 2 is off. (The switch contact is closed.) On: The shut-off 2 is on. (The switch contact is opened.) | | |
| TOF | Monitor LED for STO state Off: Not in STO state On: In STO state | | |
| SDO1 | Monitor LED for SDO1 Off: Not in STO state On: In STO state | | |
| SDO2 | Monitor LED for SDO2 Off: Not in STO state On: In STO state | | |
| SW | Monitor LED for confirming shutdown delay setting Off: The settings of SW1 and SW2 do not match. On: The settings of SW1 and SW2 match. | | |
| FAULT | FAULT LED Off: Normal operation (STO monitoring state) On: Fault has occurred. | | |
| POWER | Power supply Off: Power is not supplied to MR-J3-D05. On: Power is being supplied to MR-J3-D05. | / | |

App. 7.10 Rotary switch setting

Rotary switch is used to shut off the power after control stop by SS1 function.

Set the delay time for STO output after STO shut off switch is pressed. Set same setting for SW1 and SW2, and set the rotary switch setting according to the delay time in the table below.

Setting cannot be changed while power is on. Notify users that setting cannot be changed by putting a seal or by another method so that end users will not change the setting after the shipment.

0 to F in the following table is the set value of the rotary switches (SW1 and SW2).

Rotary switch setting and delay time at A/B-axis [s]

| | | B-axis | | | | | |
|--------|--------|--------|-------|-------|-------|-------|--------|
| | | 0 s | 1.4 s | 2.8 s | 5.6 s | 9.8 s | 30.8 s |
| A-axis | 0 s | 0 | 1 | 2 | - | 3 | 4 |
| | 1.4 s | | - | 5 | - | 6 | 7 |
| | 2.8 s | | | 8 | - | 9 | A |
| | 5.6 s | | | | - | B | C |
| | 9.8 s | | | | | D | E |
| | 30.8 s | | | | | | F |

APPENDIX

App. 7.11 Troubleshooting

When power is not supplied or FAULT LED turns on, refer the following table and take the appropriate action.

| Event | Description | Cause | Action |
|------------------------|---|--|--|
| Power is not supplied. | Power LED does not turn on although power is supplied. | 1. 24 V DC power supply is malfunctioning. | Replace the 24 V DC power supply. |
| | | 2. Wires between MR-J3-D05 and 24 V DC power supply are disconnected or are in contact with other wires. | Check the wiring. |
| | | 3. MR-J3-D05 is malfunctioning. | Replace the MR-J3-D05. |
| FAULT LED is on. | FAULT LED of A-axis or B-axis is on, and will not turn off. | 1. The delay time settings are not matched. | Check the settings of the rotary switch. |
| | | 2. Switch input error | Check the wiring or sequence of the input signals. |
| | | 3. TOF signal error | Check the connection with the servo amplifier. |
| | | 4. MR-J3-D05 is malfunctioning. | Replace the MR-J3-D05. |

App. 7.12 Dimensions

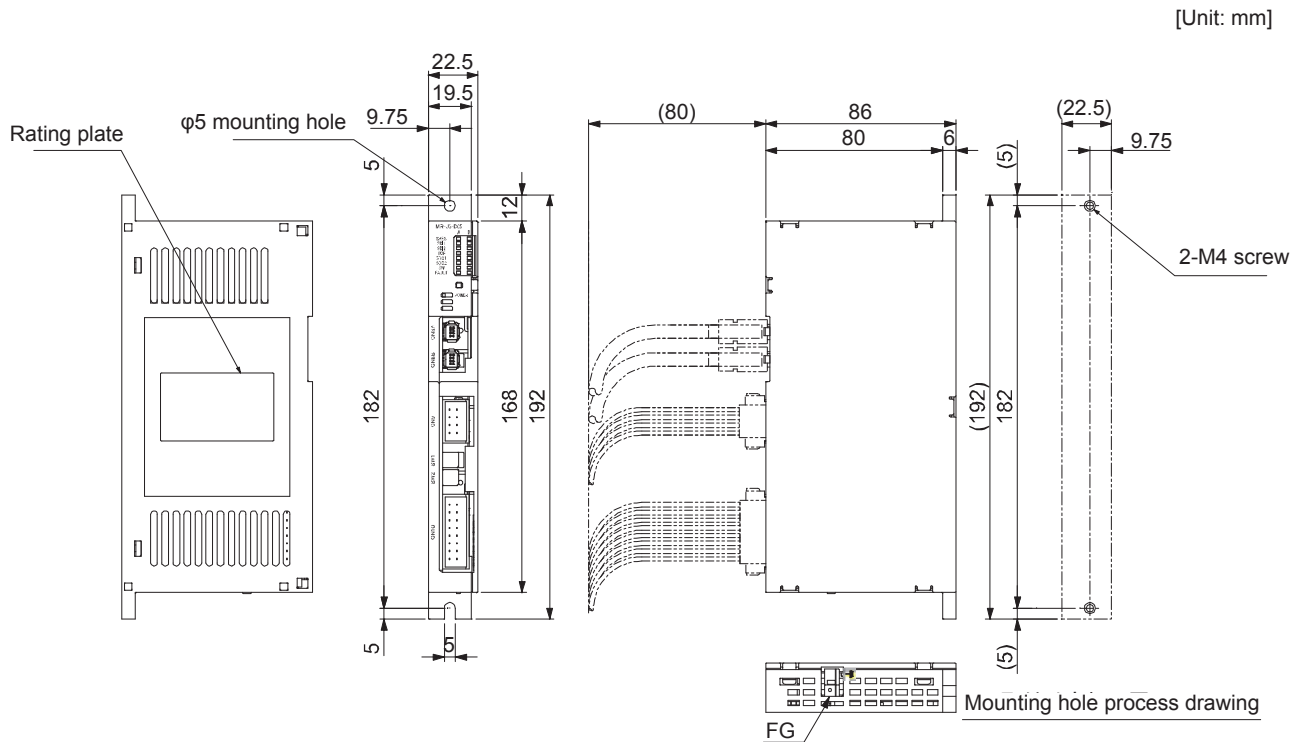

Mounting screw
 Screw size: M4
 Tightening torque: 1.2 N•m

Mass: 0.2 [kg]

APPENDIX

App. 7.13 Installation

Follow the instructions in this chapter and install MR-J3-D05 in the specified direction. Leave clearances between MR-J3-D05 and other equipment including the cabinet.

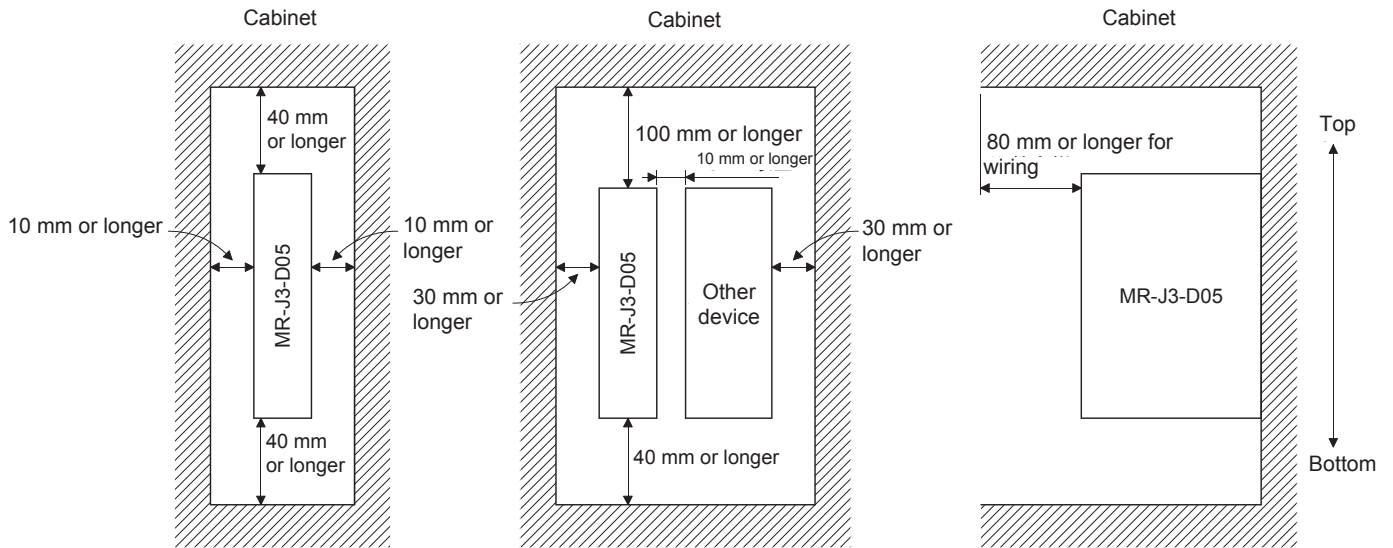



APPENDIX

App. 7.14 Combinations of cable/connector

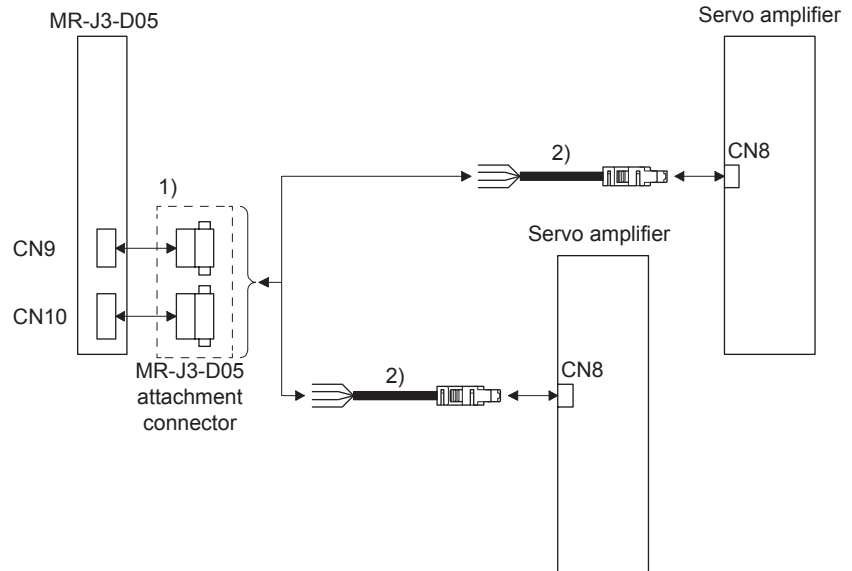
| POINT |
|---|
| ●The STO cable (MR-D05UDL-M) for MR-J3 series is not available. |



| No. | Name | Model | Description |
|-----|-----------|--|--|
| 1) | Connector | MR-J3-D05 attachment connector |   Connector for CN9: 1-1871940-4 (TE Connectivity) Connector for CN10: 1-1871940-8 (TE Connectivity) |
| 2) | STO cable | MR-D05UDL3M-B Cable length: 0.3/1/3 m | Connector set: 2069250-1 (TE Connectivity)  |

COMPLIANCE WITH THE MACHINERY DIRECTIVES

The MR-J3-D05 complies with the safety components laid down in the directive 2006/42/EC (Machinery).

App. 8 EC declaration of conformity

The MR-J3-D05 safety logic unit complies with the safety component laid down in the Machinery directive.



ZERTIFIKAT CERTIFICATE

Nr./No. 968/EL 612.00/09

| | | | |
|--|--|---|---|
| Prüfgegenstand Product tested | Safety Logic Module for usage in combination with MR-J3-ES Servo Drives | Inhaber Holder | Mitsubishi Electric Corporation Nagoya Works 1-14 Yada-Minami 5-chome, Higashi-ku Nagoya 461-8670 Japan |
| Typbezeichnung Type designation | MR-J3-D05 | Verwendungszweck Intended application | Drive Applications STO / SS1 acc. to EN 61800-5-2 Safe Stop / Safe Off Stop Category 0 / Stop Category 1 acc. to EN 60204-1 |
| Prüfgrundlagen Codes and standards forming the basis of testing | EN ISO 13849-1:2008 EN 62061:2005 EN 61800-5-2:2007 EN 61800-5-1:2007 | EN 61800-3:2004 EN 60204-1:2006 EN 50178:1997 EN 61508-1 to -7:2000-2002 | |
| Prüfungsergebnis Test results | The MR-J3-D05 Safety Logic Module in combination with the MR-J3 series servo drives is suitable for the basic safety functions "STO" and "SS1" (Type C) according to EN 61800-5-2 as well as "Safe Stop" (Stop category 0 and Stop category 1) and "Safe Off" according to EN 60204-1. It can be used within safety related applications up to Safety Category 3 / PL d and SIL 2 / SIL CL 2 according to EN ISO 13849-1 and EN 62061. | | |
| Besondere Bedingungen Specific requirements | For a safe usage of the product the instructions in the user documentation must be observed. For "Safe Off" two suitable additional magnetic contactors must be used additionally. | | |

Der Prüfbericht-Nr.: 968/EL 612.00/09 vom 21.04.2009 ist Bestandteil dieses Zertifikates.
Dieses Zertifikat ist nur gültig für Erzeugnisse, die mit dem Prüfgegenstand übereinstimmen. Es wird ungültig bei jeglicher Änderung der Prüfgrundlagen für den angegebenen Verwendungszweck.

The test report-no.: 968/EL 612.00/09 dated 2009-04-21 is an integral part of this certificate.
This certificate is valid only for products which are identical with the product tested. It becomes invalid at any change of the codes and standards forming the basis of testing for the intended application.

TÜV Rheinland Industrie Service GmbH
Geschäftsfeld ASI
Automation, Software und Informationstechnologie
Am Grauen Stein, 51105 Köln
Postfach 91 09 51, 51101 Köln



Dipl.-Ing. Heinz Gall

2009-04-21
Datum/Date

Firmenstempel/Company stamp

APPENDIX

App. 9 Analog monitor

The servo status can be output to two channels in terms of voltage.

(1) Setting

Change the following digits of [Pr. PC14] and [Pr. PC15].

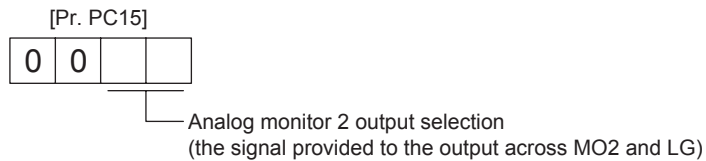
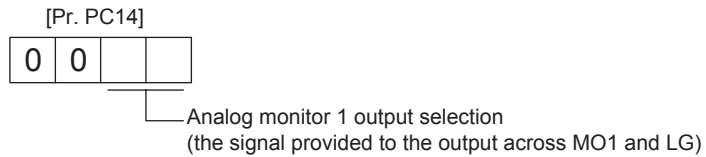

[Pr. PC39] and [Pr. PC40] can be used to set the offset voltages to the analog output voltages. The setting range is between -9999 mV and 9999 mV.

| Parameter | Description | Setting range [mV] |
|-----------|---|--------------------|
| PC39 | This is used to set the offset voltage of MO1 (Analog monitor 1). | -9999 to 9999 |
| PC40 | This is used to set the offset voltage of MO2 (Analog monitor 2). | |

(2) Set content

The servo amplifier is factory-set to output the servo motor speed to MO1 (Analog monitor 1) and the torque to MO2 (Analog monitor 2). The setting can be changed as listed below by setting the [Pr. PC14] and [Pr. PC15] value.

Refer to (3) for the detection point.

| Setting value | Output item | Description | Setting value | Output item | Description |
|---------------|-------------------|-------------|---------------|-------------------------|-------------|
| 00 | Servo motor speed | | 01 | Torque | |
| 02 | Servo motor speed | | 03 | Torque | |
| 04 | Current command | | 05 | Command pulse frequency | |

APPENDIX

| Setting value | Output item | Description | Setting value | Output item | Description |
|---------------|---|-------------|---------------|--|-------------|
| 06 | Servo motor-side droop pulses (Note 1, 3, 5) (± 10 V/100 pulses) | | 07 | Servo motor-side droop pulses (Note 1, 3, 5) (± 10 V/1000 pulses) | |
| 08 | Servo motor-side droop pulses (Note 1, 3, 5) (± 10 V/10000 pulses) | | 09 | Servo motor-side droop pulses (Note 1, 3, 5) (± 10 V/100000 pulses) | |
| 0A | Feedback position (Note 1, 2, 3) (± 10 V/1 Mpulse) | | 0B | Feedback position (Note 1, 2, 3) (± 10 V/10 Mpulse) | |
| 0C | Feedback position (Note 1, 2, 3) (± 10 V/100 Mpulse) | | 0D | Bus voltage | |
| 0E | Speed command 2 (Note 3, 4) | | 17 | Encoder inside temperature (± 10 V/ ± 128 °C) | |

- Note
1. Encoder pulse unit.
 2. Available in position control mode
 3. This cannot be used in the torque control mode.
 4. This can be used with MR Configurator2 with software version 1.02C or later.
 5. This cannot be used in the speed control mode.

(3) Analog monitor block diagram

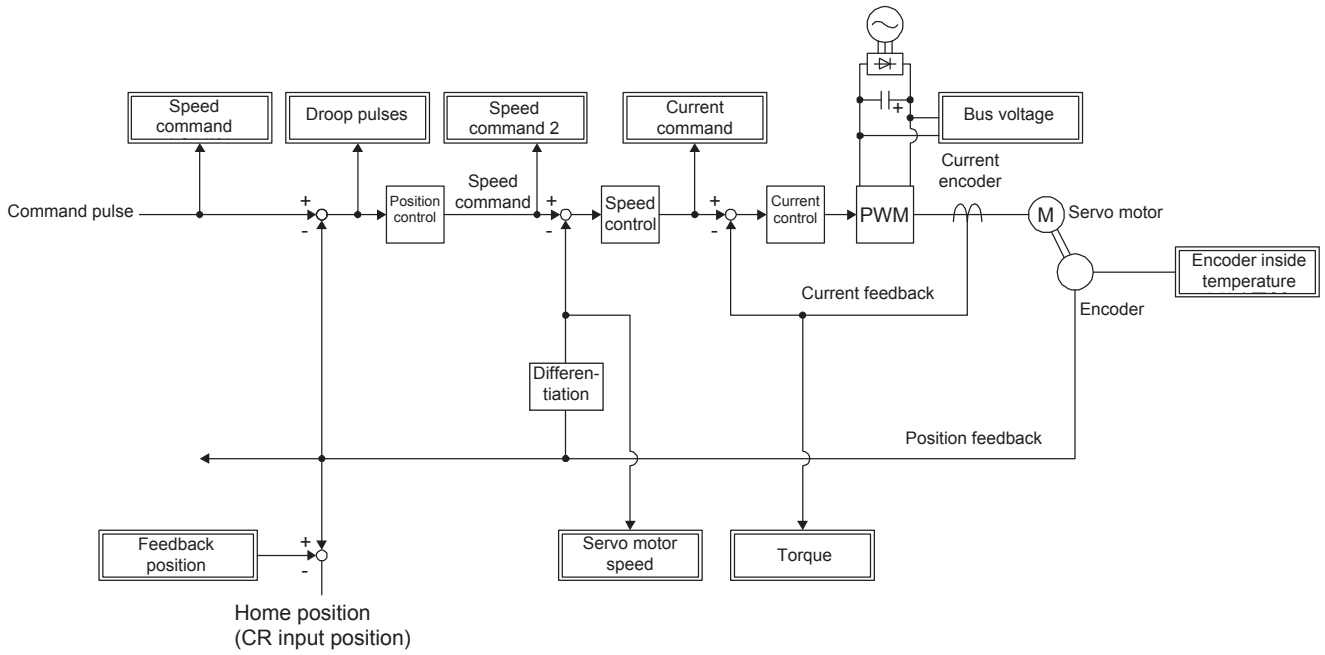

REVISIONS

*The manual number is given on the bottom left of the back cover.

| Print Data | *Manual Number | Revision |
|------------|----------------|---------------|
| Mar. 2012 | SH(NA)030107-A | First edition |
| | | |

This manual confers no industrial property rights or any rights of any other kind, nor does it confer any patent licenses. Mitsubishi Electric Corporation cannot be held responsible for any problems involving industrial property rights which may occur as a result of using the contents noted in this manual.

| Country/Region | Sales office | Tel/Fax |
|----------------|--|--|
| USA | Mitsubishi Electric Automation Inc. 500 Corporate Woods Parkway, Vernon Hills, IL 60061, USA | Tel : +1-847-478-2100 Fax : +1-847-478-0327 |
| Germany | Mitsubishi Electric Europe B.V. German Branch Gothaer Strasse 8, D-40880 Ratingen, Germany | Tel : +49-2102-486-0 Fax : +49-2102-486-1120 |
| Italy | Mitsubishi Electric Europe B.V. Italian Branch Viale Colleoni 7 1-20041 Agrate Brianza (Milano), Italy | Tel : +39-39-60531 Fax : +39-39-6053312 |
| China | Mitsubishi Electric Automation (China) Ltd. 4F Zhi Fu Plazz, No. 80 Xin Chang Road Shanghai 200003, China | Tel : +86-21-6120-0808 Fax : +86-21-6121-2444 |
| Taiwan | Setsuyo Enterprise Co., Ltd. 6F, No.105 Wu-Kung 3rd Rd, Wu-Ku Hsiang, Taipei Hsine, Taiwan | Tel : +886-2-2299-2499 Fax : +886-2-2299-2509 |
| Korea | Mitsubishi Electric Automation Korea Co., Ltd. 3F, 1480-6, Gayang-dong, Gangseo-gu, Seoul 157-200, Korea | Tel : +82-2-3660-9552 Fax : +82-2-3664-8372 |
| Singapore | Mitsubishi Electric Asia Pte, Ltd. 307 Alexandra Road #05-01/02, Mitsubishi Electric Building Singapore 159943 | Tel : +65-6470-2460 Fax : +65-6476-7439 |

Warranty

1. Warranty period and coverage

We will repair any failure or defect hereinafter referred to as "failure" in our FA equipment hereinafter referred to as the "Product" arisen during warranty period at no charge due to causes for which we are responsible through the distributor from which you purchased the Product or our service provider. However, we will charge the actual cost of dispatching our engineer for an on-site repair work on request by customer in Japan or overseas countries. We are not responsible for any on-site readjustment and/or trial run that may be required after a defective unit are repaired or replaced.

[Term]

The term of warranty for Product is twelve (12) months after your purchase or delivery of the Product to a place designated by you or eighteen (18) months from the date of manufacture whichever comes first ("Warranty Period"). Warranty period for repaired Product cannot exceed beyond the original warranty period before any repair work.

[Limitations]

- (1) You are requested to conduct an initial failure diagnosis by yourself, as a general rule.
It can also be carried out by us or our service company upon your request and the actual cost will be charged. However, it will not be charged if we are responsible for the cause of the failure.
- (2) This limited warranty applies only when the condition, method, environment, etc. of use are in compliance with the terms and conditions and instructions that are set forth in the instruction manual and user manual for the Product and the caution label affixed to the Product.
- (3) Even during the term of warranty, the repair cost will be charged on you in the following cases;
 - (i) a failure caused by your improper storing or handling, carelessness or negligence, etc., and a failure caused by your hardware or software problem
 - (ii) a failure caused by any alteration, etc. to the Product made on your side without our approval
 - (iii) a failure which may be regarded as avoidable, if your equipment in which the Product is incorporated is equipped with a safety device required by applicable laws and has any function or structure considered to be indispensable according to a common sense in the industry
 - (iv) a failure which may be regarded as avoidable if consumable parts designated in the instruction manual, etc. are duly maintained and replaced
 - (v) any replacement of consumable parts (battery, fan, smoothing capacitor, etc.)
 - (vi) a failure caused by external factors such as inevitable accidents, including without limitation fire and abnormal fluctuation of voltage, and acts of God, including without limitation earthquake, lightning and natural disasters
 - (vii) a failure generated by an unforeseeable cause with a scientific technology that was not available at the time of the shipment of the Product from our company
 - (viii) any other failures which we are not responsible for or which you acknowledge we are not responsible for

2. Term of warranty after the stop of production

- (1) We may accept the repair at charge for another seven (7) years after the production of the product is discontinued. The announcement of the stop of production for each model can be seen in our Sales and Service, etc.
- (2) Please note that the Product (including its spare parts) cannot be ordered after its stop of production.

3. Service in overseas countries

Our regional FA Center in overseas countries will accept the repair work of the Product. However, the terms and conditions of the repair work may differ depending on each FA Center. Please ask your local FA center for details.

4. Exclusion of responsibility for compensation against loss of opportunity, secondary loss, etc.

Whether under or after the term of warranty, we assume no responsibility for any damages arisen from causes for which we are not responsible, any losses of opportunity and/or profit incurred by you due to a failure of the Product, any damages, secondary damages or compensation for accidents arisen under a specific circumstance that are foreseen or unforeseen by our company, any damages to products other than the Product, and also compensation for any replacement work, readjustment, start-up test run of local machines and the Product and any other operations conducted by you.

5. Change of Product specifications

Specifications listed in our catalogs, manuals or technical documents may be changed without notice.

6. Application and use of the Product

- (1) For the use of our General-Purpose AC Servo, its applications should be those that may not result in a serious damage even if any failure or malfunction occurs in General-Purpose AC Servo, and a backup or fail-safe function should operate on an external system to General-Purpose AC Servo when any failure or malfunction occurs.
- (2) Our General-Purpose AC Servo is designed and manufactured as a general purpose product for use at general industries. Therefore, applications substantially influential on the public interest for such as atomic power plants and other power plants of electric power companies, and also which require a special quality assurance system, including applications for railway companies and government or public offices are not recommended, and we assume no responsibility for any failure caused by these applications when used.
In addition, applications which may be substantially influential to human lives or properties for such as airlines, medical treatments, railway service, incineration and fuel systems, man-operated material handling equipment, entertainment machines, safety machines, etc. are not recommended, and we assume no responsibility for any failure caused by these applications when used.
We will review the acceptability of the abovementioned applications, if you agree not to require a specific quality for a specific application. Please contact us for consultation.

| | |
|------------|---------------------------|
| MODEL | MR-J4-A INSTRUCTIONMANUAL |
| MODEL CODE | 1CW804 |

MITSUBISHI ELECTRIC CORPORATION

HEAD OFFICE : TOKYO BLDG MARUNOUCHI TOKYO 100-8310

HEADQUARTERS

| | |
|--|-------------------|
| MITSUBISHI ELECTRIC EUROPE B.V. German Branch Gothaer Straße 8 D-40880 Ratingen Phone: +49 (0)2102 / 486-0 Fax: +49 (0)2102 / 486-1120 | EUROPE |
| MITSUBISHI ELECTRIC EUROPE B.V.-org.sl. Czech Branch Avenir Business Park, Radlická 714/113a CZ-158 00 Praha 5 Phone: +420 - 251 551 470 Fax: +420 - 251-551-471 | CZECH REP. |
| MITSUBISHI ELECTRIC EUROPE B.V. French Branch 25, Boulevard des Bouvets F-92741 Nanterre Cedex Phone: +33 (0)1 / 55 68 55 68 Fax: +33 (0)1 / 55 68 57 57 | FRANCE |
| MITSUBISHI ELECTRIC EUROPE B.V. Irish Branch Westgate Business Park, Ballymount IRL-Dublin 24 Phone: +353 (0)1 4198800 Fax: +353 (0)1 4198890 | IRELAND |
| MITSUBISHI ELECTRIC EUROPE B.V. Italian Branch Viale Colleoni 7 I-20041 Agrate Brianza (MB) Phone: +39 039 / 60 53 1 Fax: +39 039 / 60 53 312 | ITALY |
| MITSUBISHI ELECTRIC EUROPE B.V. Poland Branch Krakowska 50 PL-32-083 Balice Phone: +48 (0)12 / 630 47 00 Fax: +48 (0)12 / 630 47 01 | POLAND |
| MITSUBISHI ELECTRIC EUROPE B.V. 52, bid. 3 Kosmodamienskaya nab 8 floor RU-115054 Moscow Phone: +7 495 721-2070 Fax: +7 495 721-2071 | RUSSIA |
| MITSUBISHI ELECTRIC EUROPE B.V. Spanish Branch Carretera de Rubí 76-80 E-08190 Sant Cugat del Vallés (Barcelona) Phone: 902 131121 // +34 935653131 Fax: +34 935891579 | SPAIN |
| MITSUBISHI ELECTRIC EUROPE B.V. UK Branch Travellers Lane UK-Hatfield, Herts. AL10 8XB Phone: +44 (0)1707 / 27 61 00 Fax: +44 (0)1707 / 27 86 95 | UK |
| MITSUBISHI ELECTRIC CORPORATION Office Tower "Z" 14 F 8-12,1 chome, Harumi Chuo-Ku Tokyo 104-6212 Phone: +81 3 622 160 60 Fax: +81 3 622 160 75 | JAPAN |
| MITSUBISHI ELECTRIC AUTOMATION, Inc. 500 Corporate Woods Parkway Vernon Hills, IL 60061 Phone: +1 847 478 21 00 Fax: +1 847 478 22 53 | USA |

EUROPEAN REPRESENTATIVES

| | |
|--|-------------------------------|
| GEVA Wiener Straße 89 AT-2500 Baden Phone: +43 (0)2252 / 85 55 20 Fax: +43 (0)2252 / 488 60 | AUSTRIA |
| TECHNIKON Oktyabrskaya 19, Off. 705 BY-220030 Minsk Phone: +375 (0)17 / 210 46 26 Fax: +375 (0)17 / 210 46 26 | BELARUS |
| ESCO DRIVES & AUTOMATION Culliganlaan 3 BE-1831 Diegem Phone: +32 (0)2 / 717 64 30 Fax: +32 (0)2 / 717 64 31 | BELGIUM |
| Koning & Hartman b.v. Woluwelaan 31 BE-1800 Vilvoorde Phone: +32 (0)2 / 257 02 40 Fax: +32 (0)2 / 257 02 49 | BELGIUM |
| INEA RBT d.o.o. Aleja Lipa 56 BA-71000 Sarajevo Phone: +387 (0)33 / 921 164 Fax: +387 (0)33 / 524 539 | BOSNIA AND HERZEGOVINA |
| AKHNATON 4, Andrej Ljapchev Blvd., PO Box 21 BG-1756 Sofia Phone: +359 (0)2 / 817 6000 Fax: +359 (0)2 / 97 44 06 1 | BULGARIA |
| INEA RBT d.o.o. Losinjska 4 a HR-10000 Zagreb Phone: +385 (0)1 / 36 940 - 01 / -02 / -03 Fax: +385 (0)1 / 36 940 - 03 | CROATIA |
| AutoCont C.S. s.r.o. Technologická 374/6 CZ-708 00 Ostrava-Pustkovec Phone: +420 595 691 150 Fax: +420 595 691 199 | CZECH REPUBLIC |
| Beijer Electronics A/S Lykkegårdsvej 17 DK-4000 Roskilde Phone: +45 (0)46 / 75 76 66 Fax: +45 (0)46 / 75 56 26 | DENMARK |
| Beijer Electronics Eesti OÜ Pärnu mnt.160i EE-11317 Tallinn Phone: +372 (0)6 / 51 81 40 Fax: +372 (0)6 / 51 81 49 | ESTONIA |
| Beijer Electronics OY Peltoie 37 FIN-28400 Ulvila Phone: +358 (0)207 / 463 540 Fax: +358 (0)207 / 463 541 | FINLAND |
| UTEKO 5, Mavrogenou Str. GR-18542 Piraeus Phone: +30 211 / 1206 900 Fax: +30 211 / 1206 999 | GREECE |
| MELTRADE Kft. Fertő utca 14. HU-1107 Budapest Phone: +36 (0)1 / 431-9726 Fax: +36 (0)1 / 431-9727 | HUNGARY |
| Beijer Electronics SIA Ritausmas iela 23 LV-1058 Riga Phone: +371 (0)784 / 2280 Fax: +371 (0)784 / 2281 | LATVIA |
| Beijer Electronics UAB Savanoriu Pr. 187 LT-02300 Vilnius Phone: +370 (0)5 / 232 3101 Fax: +370 (0)5 / 232 2980 | LITHUANIA |

EUROPEAN REPRESENTATIVES

| | |
|--|--------------------|
| ALFATRADE Ltd. 99, Paola Hill Malta- Paola PLA 1702 Phone: +356 (0)21 / 697 816 Fax: +356 (0)21 / 697 817 | MALTA |
| INTEHSIS srl bld. Traian 23/1 MD-2060 Kishinev Phone: +373 (0)22 / 66 4242 Fax: +373 (0)22 / 66 4280 | MOLDOVA |
| HIFLEX AUTOM.TECHNIEK B.V. Wolweverstraat 22 NL-2984 CD Ridderkerk Phone: +31 (0)180 - 46 60 04 Fax: +31 (0)180 - 44 23 55 | NETHERLANDS |
| Koning & Hartman b.v. Haarlerbergweg 21-23 NL-1101 CH Amsterdam Phone: +31 (0)20 / 587 76 00 Fax: +31 (0)20 / 587 76 05 | NETHERLANDS |
| Beijer Electronics AS Postboks 487 NO-3002 Drammen Phone: +47 (0)32 / 24 30 00 Fax: +47 (0)32 / 84 85 77 | NORWAY |
| Fonseca S.A. R. João Francisco do Casal 87/89 PT - 3801-997 Aveiro, Esgueira Phone: +351 (0)234 / 303 900 Fax: +351 (0)234 / 303 910 | PORTUGAL |
| Sirius Trading & Services srl Aleea Lacul Morii Nr. 3 RO-060841 Bucuresti, Sector 6 Phone: +40 (0)21 / 430 40 06 Fax: +40 (0)21 / 430 40 02 | ROMANIA |
| INEA SR d.o.o. Izletnicka 10 SER-113000 Smederevo Phone: +381 (0)26 / 615 401 Fax: +381 (0)26 / 615 401 | SERBIA |
| SIMAP s.r.o. Jána Derku 1671 SK-911 01 Trenčín Phone: +421 (0)32 743 04 72 Fax: +421 (0)32 743 75 20 | SLOVAKIA |
| PROCONT, spol. s r.o. Prešov Kúpeľná 1/A SK-080 01 Prešov Phone: +421 (0)51 7580 611 Fax: +421 (0)51 7580 650 | SLOVAKIA |
| INEA RBT d.o.o. Stegne 11 SI-1000 Ljubljana Phone: +386 (0)1 / 513 8116 Fax: +386 (0)1 / 513 8170 | SLOVENIA |
| Beijer Electronics AB Box 426 SE-20124 Malmö Phone: +46 (0)40 / 35 86 00 Fax: +46 (0)40 / 93 23 01 | SWEDEN |
| Omni Ray AG Im Schörl 5 CH-8600 Dübendorf Phone: +41 (0)44 / 802 28 80 Fax: +41 (0)44 / 802 28 28 | SWITZERLAND |
| GTS Bayraktar Bulvari Nutuk Sok. No:5 TR-34775 Yukarı Dudullu-Ümraniye-İSTANBUL Phone: +90 (0)216 526 39 90 Fax: +90 (0)216 526 3995 | TURKEY |
| CSC Automation Ltd. 4-B, M. Raskovoyi St. UA-02660 Kiev Phone: +380 (0)44 / 494 33 55 Fax: +380 (0)44 / 494-33-66 | UKRAINE |
| Systemgroup 2 M. Krivonosy St. UA-03680 Kiev Phone: +380 (0)44 / 490 92 29 Fax: +380 (0)44 / 248 88 68 | UKRAINE |

EURASIAN REPRESENTATIVES

| | |
|---|-------------------|
| TOO Kazpromavtomatika Ul. Zhambyla 28 KAZ-100017 Karaganda Phone: +7 7212 / 50 10 00 Fax: +7 7212 / 50 11 50 | KAZAKHSTAN |
|---|-------------------|

MIDDLE EAST REPRESENTATIVE

| | |
|---|----------------|
| SHERF Motion Techn. Ltd. Rehov Hamerkava 19 IL-58851 Holon Phone: +972 (0)3 / 559 54 62 Fax: +972 (0)3 / 556 01 82 | ISRAEL |
| CEG INTERNATIONAL Cebaco Center/Block A Autostrade DORA Lebanon - Beirut Phone: +961 (0)1 / 240 430 Fax: +961 (0)1 / 240 438 | LEBANON |

AFRICAN REPRESENTATIVE

| | |
|---|---------------------|
| CBI Ltd. Private Bag 2016 ZA-1600 Isando Phone: +27 (0)11 / 977 0770 Fax: +27 (0)11 / 977 0761 | SOUTH AFRICA |
|---|---------------------|