



Allen-Bradley

MicroLogix 1100 Programmable Controllers

**Bulletin 1763 Controllers and
1762 Expansion I/O**

User Manual

**Rockwell
Automation**

Important User Information

Solid state equipment has operational characteristics differing from those of electromechanical equipment. Safety Guidelines for the Application, Installation and Maintenance of Solid State Controls (publication SGI-1.1 available from your local Rockwell Automation sales office or online at <http://literature.rockwellautomation.com>) describes some important differences between solid state equipment and hard-wired electromechanical devices. Because of this difference, and also because of the wide variety of uses for solid state equipment, all persons responsible for applying this equipment must satisfy themselves that each intended application of this equipment is acceptable.





In no event will Rockwell Automation, Inc. be responsible or liable for indirect or consequential damages resulting from the use or application of this equipment.

The examples and diagrams in this manual are included solely for illustrative purposes. Because of the many variables and requirements associated with any particular installation, Rockwell Automation, Inc. cannot assume responsibility or liability for actual use based on the examples and diagrams.

No patent liability is assumed by Rockwell Automation, Inc. with respect to use of information, circuits, equipment, or software described in this manual.

Reproduction of the contents of this manual, in whole or in part, without written permission of Rockwell Automation, Inc., is prohibited.

Throughout this manual, when necessary, we use notes to make you aware of safety considerations.

<p>WARNING</p> 	<p>Identifies information about practices or circumstances that can cause an explosion in a hazardous environment, which may lead to personal injury or death, property damage, or economic loss.</p>
<p>IMPORTANT</p>	<p>Identifies information that is critical for successful application and understanding of the product.</p>
<p>ATTENTION</p> 	<p>Identifies information about practices or circumstances that can lead to: personal injury or death, property damage, or economic loss. Attentions help you identify a hazard, avoid a hazard, and recognize the consequence.</p>
<p>SHOCK HAZARD</p> 	<p>Labels may be on or inside the equipment, such as a drive or motor, to alert people that dangerous voltage may be present.</p>
<p>BURN HAZARD</p> 	<p>Labels may be on or inside the equipment, such as a drive or motor, to alert people that surfaces may reach dangerous temperatures.</p>

Rockwell Automation, Allen-Bradley, ControlFLASH, SLC, SLC 500, PLC-5, MicroLogix, PanelView, RSLinx, RSLogix, and RSLogix 500 are trademarks of Rockwell Automation, Inc.

Trademarks not belonging to Rockwell Automation are property of their respective companies.

To help you find new and updated information in this release of the manual, we have included change bars as shown to the right of this paragraph.

The table below lists the sections that document new features and additional or updated information on existing features.

For this information:	See
Updated Appendix D "Using ControlFLASH to Upgrade Your Operating System" with instructions for installing and using ControlFLASH version 13.00 and new DMK disk image format firmware files.	D-195

Firmware Revision History

Features are added to the controllers through firmware upgrades. See the latest release notes, [1763-RN003](#), to be sure that your controller's firmware is at the level you need. Firmware upgrades are not required, except to allow you access to the new features.

Notes:

	Firmware Revision History	1
Table of Contents	Preface	
	Who Should Use this Manual	9
	Purpose of this Manual	9
	Related Documentation.	10
	Common Techniques Used in this Manual.	10
	Chapter 1	
Hardware Overview	Hardware Features	11
	Component Descriptions.	12
	MicroLogix 1100 Memory Module and Built-in Real-Time Clock	12
	1762 Expansion I/O	13
	Communication Cables	14
	Programming	16
	Communication Options.	16
	Chapter 2	
Installing Your Controller	Agency Certifications	19
	Compliance to European Union Directives	19
	EMC Directive.	20
	Low Voltage Directive.	20
	Installation Considerations	20
	Safety Considerations.	21
	Hazardous Location Considerations.	21
	Disconnecting Main Power	23
	Safety Circuits.	23
	Power Distribution	23
	Periodic Tests of Master Control Relay Circuit	24
	Power Considerations	24
	Isolation Transformers	24
	Power Supply Inrush.	24
	Loss of Power Source	25
	Input States on Power Down	25
	Other Types of Line Conditions.	25
	Preventing Excessive Heat.	25
	Master Control Relay	26
	Using Emergency-Stop Switches	27
	Schematic (Using IEC Symbols)	28
	Schematic (Using ANSI/CSA Symbols).	29
	Installing a Memory Module	30
	Using the Battery	31
	Connecting the Battery Wire Connector	32
	Controller Mounting Dimensions	33
	Controller and Expansion I/O Spacing	33
	Mounting the Controller	34
	DIN Rail Mounting	35

	Panel Mounting	36
	1762 Expansion I/O Dimensions	37
	Mounting 1762 Expansion I/O	37
	DIN Rail Mounting	37
	Panel Mounting	38
	Connecting Expansion I/O	39
	Chapter 3	
Wiring Your Controller	Wiring Requirements	41
	Wiring Recommendation	41
	Wiring the Terminal Block	42
	Using Surge Suppressors	43
	Recommended Surge Suppressors	45
	Grounding the Controller	46
	Wiring Diagrams	47
	Terminal Block Layouts	47
	Terminal Groupings	49
	Sinking and Sourcing Wiring Diagrams	50
	1763-L16AWA, 1763-L16BWA, 1763-L16BBB and 1763-L16DWD	
	Wiring Diagrams	50
	Controller I/O Wiring	53
	Minimizing Electrical Noise	53
	Wiring Your Analog Channels	53
	Analog Channel Wiring Guidelines	53
	Minimizing Electrical Noise on Analog Channels	54
	Grounding Your Analog Cable	55
	Expansion I/O Wiring	56
	Digital Wiring Diagrams	56
	Analog Wiring	63
	Chapter 4	
Communication Connections	Supported Communication Protocols	71
	Default Communication Configuration	72
	Using the Communications Toggle Functionality	72
	Changing Communication Configuration	73
	Connecting to the RS-232 Port	76
	Making a DF1 Point-to-Point Connection	77
	Using a Modem	78
	Connecting to a DF1 Half-Duplex Network	80
	Connecting to a DH-485 Network	83
	DH-485 Configuration Parameters	83
	Recommended Tools	85
	DH-485 Communication Cable	85
	Connecting the Communication Cable to the DH-485 Connector	86

Grounding and Terminating the DH-485 Network	87
Connecting the AIC+	89
Cable Selection Guide	90
Recommended User-Supplied Components	93
Safety Considerations	94
Install and Attach the AIC+	94
Powering the AIC+	95
Connecting to Ethernet	97
Ethernet Connections	97

Chapter 5

Using the LCD

Operating Principles	100
Startup Screen	101
Main Menu and Default Screen	102
Operating Buttons	104
Using Menus to Choose Values	104
Selecting Between Menu Items	105
Cursor Display	105
Setting Values	106
I/O Status	107
Viewing I/O Status	108
Monitoring Bit File	109
Target Bit File Number (TBF)	109
Monitoring a Bit File	111
Monitoring Integer File	115
Target Integer File Number (TIF)	115
Monitoring an Integer File	117
Using the Mode Switch	122
Controller Modes	122
Changing Mode Switch Position	123
Using a User Defined LCD Screen	126
User Defined LCD Screen	126
Configuring Advanced Settings	128
Changing Key In Mode	128
Key In Modes	128
Changing Key In Mode	129
Using Communications Toggle Functionality	131
Viewing Ethernet Port Configuration	131
Using Trim Pots	133
Trim Pot Operation	133
Changing Data Value of a Trim Pot	133
Trim Pot Configuration in LCD Function File	135
Error Conditions	135
Viewing System Information	136
Viewing Fault Code	137

Using Real-Time Clock and Memory Modules	Chapter 6	
	Real-Time Clock Operation	139
	Operation at Power-up and Entering a Run or Test Mode	139
	Writing Data to the Real-Time Clock	140
	RTC Battery Operation	140
	Memory Module Operation	141
	User Program , User Data and Recipe Back-up	141
	Program Compare	141
	Data File Download Protection	142
	Memory Module Write Protection	142
	Removal/Insertion Under Power	142
	Memory Module Information File	142
	Program /Data Download	143
	Program /Data Upload	143
Online Editing	Chapter 7	
	Overview of Online Editing	145
	Online Editing Terms	146
	Effects of Online Editing On Your System	147
	System Impacts	147
	Data Table File Size	148
	Online Edit Error	148
	Directions and Cautions for MicroLogix 1100 Online Edit User	148
	Change the RSLinx "Configure CIP Option" (OS Series A FRN 1,2, and 3 only)	148
	A Download Before Starting Online Edit	149
	Types of Online Editing	151
	Edit Functions in Runtime Online Editing	152
	Edit Functions in Program Online Editing	152
Specifications	Appendix A	
	Expansion I/O Specifications	163
	Digital I/O Modules	163
	Analog Modules	171
Replacement Parts	Appendix B	
	MicroLogix 1100 Replacement Kits	179
	Lithium Battery (1763-BA)	180
	Installation	180
	Battery Handling	181
	Storage	181
	Transportation	181
	Disposal	182

Troubleshooting Your System	Appendix C	
	Understanding the Controller Indicator Status	185
	Controller Status LED Indicators	185
	Status Indicators on the LCD	186
	I/O Status Indicators on the LCD	187
	Normal Operation	188
	Error Conditions	188
	Controller Error Recovery Model	189
	Analog Expansion I/O Diagnostics and Troubleshooting	190
	Module Operation and Channel Operation	190
	Power-up Diagnostics	190
	Critical and Non-Critical Errors	191
	Module Error Definition Table	191
	Error Codes	193
	Calling Rockwell Automation for Assistance	194
Using ControlFLASH to Upgrade Your Operating System	Appendix D	
	Preparing for Firmware Upgrade	195
	Install ControlFLASH Software	195
	Use DMK Extraction Tool for Firmware Upgrade	198
	Prepare the Controller for Updating	199
	Sequence of Operation	200
	Missing/Corrupt OS LED Pattern	201
Connecting to Networks via RS-232/RS-485 Interface	Appendix E	
	RS-232 Communication Interface	203
	RS-485 Communication Interface	203
	DF1 Full-Duplex Protocol	203
	DF1 Half-Duplex Protocol	205
	DF1 Half-Duplex Operation	205
	Considerations When Communicating as a DF1 Slave on a Multi-drop Link	206
	Using Modems with MicroLogix™ Programmable Controllers	207
	DH-485 Communication Protocol	209
	DH-485 Configuration Parameters	209
	Devices that use the DH-485 Network	210
	Important DH-485 Network Planning Considerations	210
	Example DH-485 Connections	214
	Modbus Communication Protocol	216
	ASCII	216
Connecting to Networks via Ethernet Interface	Appendix F	
	MicroLogix 1100 Controllers and Ethernet Communication	217
	MicroLogix 1100 Performance Considerations	218

MicroLogix 1100 and PC Connections to the Ethernet Network 220

 Ethernet Network Topology..... 220

 Connecting an Ethernet switch on the Ethernet Network 220

 Cables 221

Ethernet Connections 223

Duplicate IP address Detection 224

Configuring the Ethernet Channel on the MicroLogix 1100..... 225

Configuration Using RSLogix 500 Programming Software..... 226

Configuration Via BOOTP 226

 Using the Rockwell BOOTP/DHCP Utility 228

Using a DHCP Server To Configure Your Processor 230

Using Subnet Masks and Gateways..... 230

 Manually Configuring Channel 1 for Controllers on Subnets... 232

MicroLogix 1100 Embedded Web Server Capability 233

Appendix G

System Loading Calculations 235

 System Loading Example Calculations 236

System Loading Worksheet..... 238

 Current Loading..... 238

Calculating Heat Dissipation 240

Glossary

Index

System Loading and Heat Dissipation

Read this preface to familiarize yourself with the rest of the manual. It provides information concerning:

- who should use this manual
- the purpose of this manual
- related documentation
- conventions used in this manual
- Rockwell Automation support

Who Should Use this Manual

Use this manual if you are responsible for designing, installing, programming, or troubleshooting control systems that use MicroLogix™ 1100 controllers.

You should have a basic understanding of electrical circuitry and familiarity with relay logic. If you do not, obtain the proper training before using this product.

Purpose of this Manual

This manual is a reference guide for MicroLogix 1100 controllers and expansion I/O. It describes the procedures you use to install, wire, and troubleshoot your controller. This manual:

- explains how to install and wire your controllers
- gives you an overview of the MicroLogix 1100 controller system

Refer to publication 1763-RM001, MicroLogix 1100 Programmable Controllers Instruction Set Reference Manual for the MicroLogix 1100 instruction set and for application examples to show the instruction set in use. Refer to your RSLogix 500 programming software user documentation for more information on programming your MicroLogix 1100 controller.

Related Documentation

The following documents contain additional information concerning Rockwell Automation products. To obtain a copy, contact your local Rockwell Automation office or distributor.

Resource	Description
MicroLogix 1100 Programmable Controllers Instruction Set Reference Manual, publication 1763-RM001	Information on the MicroLogix 1100 Controllers instruction set.
MicroLogix 1100 Programmable Controllers Installation Instructions, publication 1763-IN001	Information on mounting and wiring the MicroLogix 1100 Controllers, including a mounting template for easy installation.
Advanced Interface Converter (AIC+) User Manual, publication 1761-UM004	A description on how to install and connect an AIC+. This manual also contains information on network wiring.
DeviceNet Interface User Manual, publication 1761-UM005	Information on how to install, configure, and commission a DNI.
DF1 Protocol and Command Set Reference Manual, publication 1770-6.5.16	Information on DF1 open protocol.
Modbus Protocol Specifications Available from www.modbus.org	Information about the Modbus protocol.
Allen-Bradley Programmable Controller Grounding and Wiring Guidelines, publication 1770-4.1	In-depth information on grounding and wiring Allen-Bradley programmable controllers.
Application Considerations for Solid-State Controls, publication SGL-1.1	A description of important differences between solid-state programmable controller products and hard-wired electromechanical devices.
National Electrical Code - Published by the National Fire Protection Association of Boston, MA.	An article on wire sizes and types for grounding electrical equipment.
Allen-Bradley Publication Index SD499	A complete listing of current documentation, including ordering instructions. Also indicates whether the documents are available on CD-ROM or in multi-languages.
Allen-Bradley Industrial Automation Glossary, publication AG-7.1	A glossary of industrial automation terms and abbreviations.

Common Techniques Used in this Manual

The following conventions are used throughout this manual:

- Bulleted lists such as this one provide information, not procedural steps.
- Numbered lists provide sequential steps or hierarchical information.
- *Italic* type is used for emphasis.

Hardware Overview

Hardware Features

The Bulletin 1763, MicroLogix 1100 programmable controller contains a power supply, input and output circuits, a processor, an isolated combination RS-232/485 communication port, and an Ethernet port. Each controller supports 18 I/O points (10 digital inputs, 2 analog inputs, and 6 discrete outputs).

The hardware features of the controller are shown below.

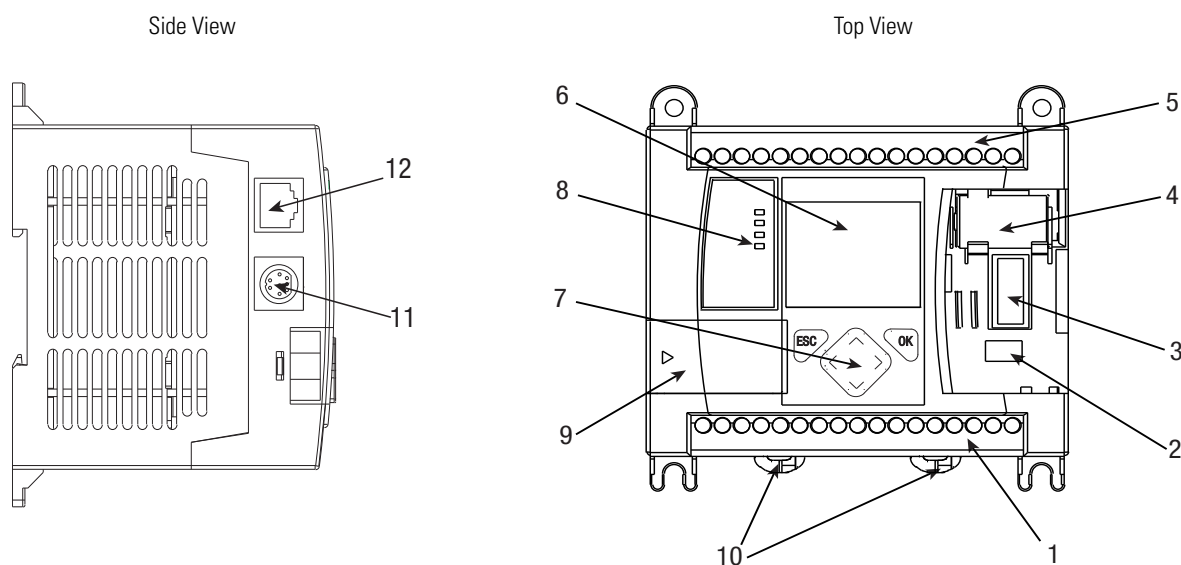

Hardware Features

Feature	Description	Feature	Description
1	Output Terminal Block	7	LCD Keypad (ESC, OK, Up, Down, Left, Right)
2	Battery Connector	8	Status LED indicators
3	Bus Connector Interface to Expansion I/O	9	Memory Module Port Cover ⁽¹⁾ -or- Memory Module ⁽²⁾
4	Battery	10	DIN Rail Latches
5	Input Terminal Block	11	RS-232/485 Communication Port (Channel 0, isolated)
6	LCD	12	Ethernet Port (Channel 1)

⁽¹⁾ Shipped with controller.

⁽²⁾ Optional equipment.

Controller Input Power and Embedded I/O

Catalog Number	Description			
	Input Power	Digital Inputs	Analog Inputs	Digital Outputs
1763-L16AWA	120/240V AC	(10) 120V AC	(2) voltage input 0...10V DC	(6) relay All individually isolated
1763-L16BWA	120/240V AC	(6) 24V DC (4) high-speed 24V DC ⁽¹⁾	(2) voltage input 0...10V DC	(6) relay All individually isolated
1763-L16BBB	24V DC	(6) 24V DC (4) high-speed 24V DC ⁽¹⁾	(2) voltage input 0...10V DC	(2) relay (isolated) (2) 24V DC FET (2) high-speed 24V DC FET
1763-L16DWD	12...24V DC	(6) 12...24V DC (4) high-speed 12/24V DC ⁽¹⁾	(2) voltage input 0...10V DC	(6) relay All individually isolated

⁽¹⁾ The 4 high-speed inputs (inputs 0 through 3) can be used individually for pulse catch/latching inputs or combined as a high speed counter. Refer to Digital Input Specifications on page 155 and the MicroLogix 1100 Instruction Set Reference Manual, publication 1763-RM001, for more information.

Component Descriptions**MicroLogix 1100 Memory Module and Built-in Real-Time Clock**

The controller has a built-in real-time clock to provide a reference for applications that need time-based control.

The controller is shipped with a memory module port cover in place. You can order a memory module, 1763-MM1, as an accessory. The memory module provides optional backup of your user program and data, and is a means to transport your programs between controllers.

The program and data in your MicroLogix 1100 is non-volatile and is stored when the power is lost to the controller. The memory module provides additional backup that can be stored separately. The memory module does not increase the available memory of the controller.

1763-MM1 Memory Module

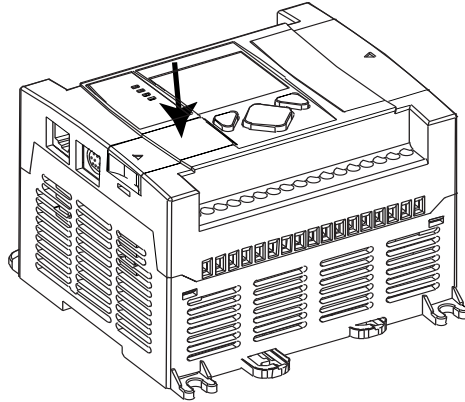

1762 Expansion I/O

1762 expansion I/O can be connected to the MicroLogix 1100 controller, as shown below.

TIP

A maximum of four I/O modules, in *any* combination, can be connected to a controller. See Appendix G to determine how much heat a certain combination generates.

1762 Expansion I/O

1762 Expansion I/O

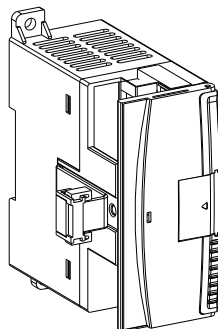

1762 Expansion I/O Connected to MicroLogix 1100 Controller

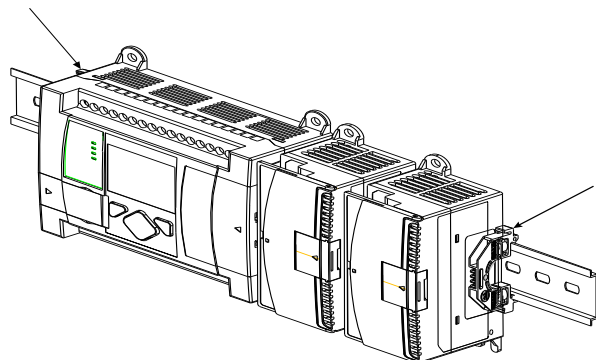

Expansion I/O

Catalog Number	Description
Digital	
1762-IA8	8-Point 120V AC Input Module
1762-IQ8	8-Point Sink/Source 24V DC Input Module
1762-IQ16	16-Point Sink/Source 24V DC Input Module
1762-IQ32T	32-Point Sink/Source 24V DC Input Module
1762-OA8	8-Point 120/240V AC Triac Output Module
1762-OB8	8-Point Sourcing 24V DC Output Module
1762-OB16	16-Point Sourcing 24V DC Output Module
1762-OB32T	32-Point Sourcing 24V DC Output Module
1762-OV32T	32-Point Sinking 24V DC Output Module
1762-OW8	8-Point AC/DC Relay Output Module
1762-OW16	16-Point AC/DC Relay Output Module
1762-OX6I	6-Point Isolated AC/DC Relay Output Module
1762-IQ8OW6	8-Point Sink/Source 24V DC Input and 6-Point AC/DC Relay Output Module
Analog	
1762-IF4	4-Channel Voltage/Current Analog Input Module
1762-OF4	4-Channel Voltage/Current Analog Output Module
1762-IF2OF2	Combination 2-Channel Input 2-Channel Output Voltage/Current Analog Module
Temperature	
1762-IR4	4-Channel RTD/Resistance Input Module
1762-IT4	4-Channel Thermocouple/mV Input Module

Communication Cables

Use only the following communication cables with the MicroLogix 1100 controllers. These cables are required for Class I Div. 2 applications.

- 1761-CBL-AM00 Series C or later
- 1761-CBL-AP00 Series C or later
- 1761-CBL-PM02 Series C or later
- 1761-CBL-HM02 Series C or later
- 1761-CBL-PH02 Series A or later
- 1761-CBL-AH02 Series A or later
- 2707-NC9 Series C or later
- 1763-NC01 Series A or later

ATTENTION**UNSUPPORTED CONNECTION**

Do not connect a MicroLogix 1100 controller to another MicroLogix family controller such as MicroLogix 1000, MicroLogix 1200, MicroLogix 1500, or the network port of a 1747-DPS1 Port Splitter using a 1761-CBL-AM00 (8-pin mini-DIN to 8-pin mini-DIN) cable or equivalent.

This type of connection will cause damage to the RS-232/485 communication port (Channel 0) of the MicroLogix 1100 and/or the controller itself. The communication pins used for RS-485 communications on the MicroLogix 1100 are alternately used for 24V power on the other MicroLogix controllers and the network port of the 1747-DPS1 Port Splitter.

Programming

Programming the MicroLogix 1100 controller is done using RSLogix 500, Revision 7.0 or later. To use all of the latest features, RSLogix 500 programming software must be version 7.20.00 or later. Communication cables for programming are available separately from the controller and software.

Communication Options

The MicroLogix 1100 controllers provide two communications ports, an isolated combination RS-232/485 communication port (Channel 0) and an Ethernet port (Channel 1).

The isolated Channel 0 port on the MicroLogix 1100 can be connected to the following:

- operator interfaces, personal computers, etc. using DF1 Full Duplex point-to-point
- a DH-485 network
- a DF1 Radio Modem network
- a DF1 half-duplex network as an RTU Master or RTU Slave
- a Modbus network as an RTU Master or RTU Slave
- an ASCII network
- an Ethernet network using the Ethernet Interface module (catalog number 1761-NET-ENI, or 1761-NET-ENIW)

When connecting to a DH-485 network, DF1 half-duplex network⁽¹⁾ or a Modbus network, the MicroLogix 1100 can be connected directly via Channel 0 (without an Advanced Interface Converter, catalog number 1761-NET-AIC). The Channel 0 combo port provides both RS-232 and RS-485 isolated connections. The appropriate electrical interface is selected through your choice of communication cable. The existing MicroLogix 1761 communication cables provide an interface to the RS-232 drivers. The 1763-NC01 cable provides an interface to the RS-485 drivers (for DH-485, Modbus RTU Master, RTU slave networks, DF1 half-duplex Master⁽¹⁾ and DF1 half-duplex Slave⁽¹⁾).

The controller may also be connected to serial devices, such as bar code readers, weigh scales, serial printers, and other intelligent devices, using ASCII. See Default Communication Configuration on page 72 for the configuration settings for Channel 0. MicroLogix 1100 can be connected directly to RS-485 network via channel 0, using ASCII⁽¹⁾.

The MicroLogix 1100 supports Ethernet communication via the Ethernet communication Channel 1. You can connect your controller to a local area network that provides communication between various devices at 10 Mbps or 100 Mbps. This port supports CIP explicit messaging (message exchange) only.

⁽¹⁾ OS Series B FRN4 or later.

The controller cannot be used for CIP implicit messaging (real-time I/O messaging). The controller also includes an embedded web server which allows viewing of not only module information, TCP/IP configuration, and diagnostic information, but also includes the data table memory map and data table monitor screen using a standard web browser.

See Chapter 4 for more information on connecting to the available communication options.

Notes:

Installing Your Controller

This chapter shows you how to install your controller. The only tools you require are a flat or Phillips head screwdriver and drill. Topics include:

- agency certifications
- compliance to European Union Directives
- installation considerations
- safety considerations
- power considerations
- preventing excessive heat
- master control relay
- installing a memory module
- using the battery
- controller mounting dimensions
- controller and expansion I/O spacing
- mounting the controller
- mounting 1762 expansion I/O
- connecting 1762 expansion I/O

Agency Certifications

- UL Listed Industrial Control Equipment for use in Class I, Division 2, Hazardous Locations, Groups A, B, C, D
- C-UL Listed Industrial Control Equipment for use in Canada
- CE marked for all applicable directives
- C-Tick marked for all applicable acts

Compliance to European Union Directives

This product has the CE mark and is approved for installation within the European Union and EEA regions. It has been designed and tested to meet the following directives.

EMC Directive

This product is tested to meet Council Directive 89/336/EEC Electromagnetic Compatibility (EMC) and the following standards, in whole or in part, documented in a technical construction file:

- EN 61000-6-4
EMC - Part 6-4: Generic Standards - Emission Standard for Industrial Environments
- EN 61000-6-2
EMC - Part 6-2: Generic Standards - Immunity for Industrial Environments

This product is intended for use in an industrial environment.

Low Voltage Directive

This product is tested to meet Council Directive 73/23/EEC Low Voltage, by applying the safety requirements of EN 61131-2 Programmable Controllers, Part 2 - Equipment Requirements and Tests.

For specific information required by EN 61131-2, see the appropriate sections in this publication, as well as the following Allen-Bradley publications:

- *Industrial Automation Wiring and Grounding Guidelines for Noise Immunity*, publication 1770-4.1
- *Guidelines for Handling Lithium Batteries*, publication AG-5.4
- *Automation Systems Catalog*, publication B115

Installation Considerations

Most applications require installation in an industrial enclosure (Pollution Degree 2⁽¹⁾) to reduce the effects of electrical interference (Over Voltage Category II⁽²⁾) and environmental exposure. Locate your controller as far as possible from power lines, load lines, and other sources of electrical noise such as hard-contact switches, relays, and AC motor drives. For more information on proper grounding guidelines, see the *Industrial Automation Wiring and Grounding Guidelines* publication 1770-4.1.

⁽¹⁾ Pollution Degree 2 is an environment where normally only non-conductive pollution occurs except that occasionally temporary conductivity caused by condensation shall be expected.

⁽²⁾ Overvoltage Category II is the load level section of the electrical distribution system. At this level, transient voltages are controlled and do not exceed the impulse voltage capability of the products insulation.

ATTENTION

Electrostatic discharge can damage semiconductor devices inside the controller. Do not touch the connector pins or other sensitive areas.

ATTENTION

Vertical mounting of the controller is not supported due to heat build-up considerations.

ATTENTION

Be careful of metal chips when drilling mounting holes for your controller or other equipment within the enclosure or panel. Drilled fragments that fall into the controller or I/O modules could cause damage. Do not drill holes above a mounted controller if the protective debris shields are removed or the processor is installed.

Safety Considerations

Safety considerations are an important element of proper system installation. Actively thinking about the safety of yourself and others, as well as the condition of your equipment, is of primary importance. We recommend reviewing the following safety considerations.

Hazardous Location Considerations

This equipment is suitable for use in Class I, Division 2, Groups A, B, C, D or non-hazardous locations only. The following WARNING statement applies to use in hazardous locations.

WARNING



EXPLOSION HAZARD

- Substitution of components may impair suitability for Class I, Division 2.
- Do not replace components or disconnect equipment unless power has been switched off.
- Do not connect or disconnect components unless power has been switched off.
- This product must be installed in an enclosure. All cables connected to the product must remain in the enclosure or be protected by conduit or other means.
- All wiring must comply with N.E.C. article 501-10(b).
- The interior of the enclosure must be accessible only by the use of a tool.
- For applicable equipment (for example, relay modules), exposure to some chemicals may degrade the sealing properties of the materials used in these devices:
 - Relays, epoxy

It is recommended that you periodically inspect these devices for any degradation of properties and replace the module if degradation is found.

Use only the following communication cables in Class I, Division 2 hazardous locations.

Communication Cables for Class I, Division 2 Hazardous Locations

1761-CBL-AM00 Series C or later

1761-CBL-AP00 Series C or later

1761-CBL-PM02 Series C or later

1761-CBL-HM02 Series C or later

1761-CBL-PH02 Series A or later

1761-CBL-AH02 Series A or later

2707-NC9 Series C or later

1763-NC01 Series A or later

Disconnecting Main Power

WARNING

Explosion Hazard

Do not replace components, connect equipment, or disconnect equipment unless power has been switched off.

The main power disconnect switch should be located where operators and maintenance personnel have quick and easy access to it. In addition to disconnecting electrical power, all other sources of power (pneumatic and hydraulic) should be de-energized before working on a machine or process controlled by a controller.

Safety Circuits

WARNING

Explosion Hazard

Do not connect or disconnect connectors while circuit is live.

Circuits installed on the machine for safety reasons, like overtravel limit switches, stop push buttons, and interlocks, should always be hard-wired directly to the master control relay. These devices must be wired in series so that when any one device opens, the master control relay is de-energized, thereby removing power to the machine. Never alter these circuits to defeat their function. Serious injury or machine damage could result.

Power Distribution

There are some points about power distribution that you should know:

- The master control relay must be able to inhibit all machine motion by removing power to the machine I/O devices when the relay is de-energized. It is recommended that the controller remain powered even when the master control relay is de-energized.
- If you are using a DC power supply, interrupt the load side rather than the AC line power. This avoids the additional delay of power supply turn-off. The DC power supply should be powered directly from the fused secondary of the transformer. Power to the DC input and output circuits should be connected through a set of master control relay contacts.

Periodic Tests of Master Control Relay Circuit

Any part can fail, including the switches in a master control relay circuit. The failure of one of these switches would most likely cause an open circuit, which would be a safe power-off failure. However, if one of these switches shorts out, it no longer provides any safety protection. These switches should be tested periodically to assure they will stop machine motion when needed.

Power Considerations

The following explains power considerations for the micro controllers.

Isolation Transformers

You may want to use an isolation transformer in the AC line to the controller. This type of transformer provides isolation from your power distribution system to reduce the electrical noise that enters the controller and is often used as a step-down transformer to reduce line voltage. Any transformer used with the controller must have a sufficient power rating for its load. The power rating is expressed in volt-amperes (VA).

Power Supply Inrush

During power-up, the MicroLogix 1100 power supply allows a brief inrush current to charge internal capacitors. Many power lines and control transformers can supply inrush current for a brief time. If the power source cannot supply this inrush current, the source voltage may sag momentarily.

The only effect of limited inrush current and voltage sag on the MicroLogix 1100 is that the power supply capacitors charge more slowly. However, the effect of a voltage sag on other equipment should be considered. For example, a deep voltage sag may reset a computer connected to the same power source. The following considerations determine whether the power source must be required to supply high inrush current:

- The power-up sequence of devices in a system.
- The amount of the power source voltage sag if the inrush current cannot be supplied.
- The effect of voltage sag on other equipment in the system.

If the entire system is powered-up at the same time, a brief sag in the power source voltage typically will not affect any equipment.

Loss of Power Source

The power supply is designed to withstand brief power losses without affecting the operation of the system. The time the system is operational during power loss is called program scan hold-up time after loss of power. The duration of the power supply hold-up time depends on the type and state of the I/O, but is typically between 10 milliseconds and 3 seconds. When the duration of power loss reaches this limit, the power supply signals the processor that it can no longer provide adequate DC power to the system. This is referred to as a power supply shutdown. The processor then performs an orderly shutdown of the controller.

Input States on Power Down

The power supply hold-up time as described above is generally longer than the turn-on and turn-off times of the inputs. Because of this, the input state change from “On” to “Off” that occurs when power is removed may be recorded by the processor before the power supply shuts down the system. Understanding this concept is important. The user program should be written to take this effect into account.

Other Types of Line Conditions

Occasionally the power source to the system can be temporarily interrupted. It is also possible that the voltage level may drop substantially below the normal line voltage range for a period of time. Both of these conditions are considered to be a loss of power for the system.

Preventing Excessive Heat

For most applications, normal convective cooling keeps the controller within the specified operating range. Ensure that the specified temperature range is maintained. Proper spacing of components within an enclosure is usually sufficient for heat dissipation.

In some applications, a substantial amount of heat is produced by other equipment inside or outside the enclosure. In this case, place blower fans inside the enclosure to assist in air circulation and to reduce “hot spots” near the controller.

Additional cooling provisions might be necessary when high ambient temperatures are encountered.

TIP

Do not bring in unfiltered outside air. Place the controller in an enclosure to protect it from a corrosive atmosphere. Harmful contaminants or dirt could cause improper operation or damage to components. In extreme cases, you may need to use air conditioning to protect against heat build-up within the enclosure.

Master Control Relay

A hard-wired master control relay (MCR) provides a reliable means for emergency machine shutdown. Since the master control relay allows the placement of several emergency-stop switches in different locations, its installation is important from a safety standpoint. Overtravel limit switches or mushroom-head push buttons are wired in series so that when any of them opens, the master control relay is de-energized. This removes power to input and output device circuits. Refer to the figures on pages 28 and 29.

ATTENTION

Never alter these circuits to defeat their function since serious injury and/or machine damage could result.

TIP

If you are using an external DC power supply, interrupt the DC output side rather than the AC line side of the supply to avoid the additional delay of power supply turn-off.

The AC line of the DC output power supply should be fused.

Connect a set of master control relays in series with the DC power supplying the input and output circuits.

Place the main power disconnect switch where operators and maintenance personnel have quick and easy access to it. If you mount a disconnect switch inside the controller enclosure, place the switch operating handle on the outside of the enclosure, so that you can disconnect power without opening the enclosure.

Whenever any of the emergency-stop switches are opened, power to input and output devices should be removed.

When you use the master control relay to remove power from the external I/O circuits, power continues to be provided to the controller's power supply so that diagnostic indicators on the processor can still be observed.

The master control relay is not a substitute for a disconnect to the controller. It is intended for any situation where the operator must quickly de-energize I/O devices only. When inspecting or installing terminal connections, replacing output fuses, or working on equipment within the enclosure, use the disconnect to shut off power to the rest of the system.

TIP

Do not control the master control relay with the controller. Provide the operator with the safety of a direct connection between an emergency-stop switch and the master control relay.

Using Emergency-Stop Switches

When using emergency-stop switches, adhere to the following points:

- Do not program emergency-stop switches in the controller program. Any emergency-stop switch should turn off all machine power by turning off the master control relay.
- Observe all applicable local codes concerning the placement and labeling of emergency-stop switches.
- Install emergency-stop switches and the master control relay in your system. Make certain that relay contacts have a sufficient rating for your application. Emergency-stop switches must be easy to reach.
- In the following illustration, input and output circuits are shown with MCR protection. However, in most applications, only output circuits require MCR protection.

The following illustrations show the Master Control Relay wired in a grounded system.

TIP

In most applications input circuits do not require MCR protection; however, if you need to remove power from all field devices, you must include MCR contacts in series with input power wiring.

Schematic (Using IEC Symbols)

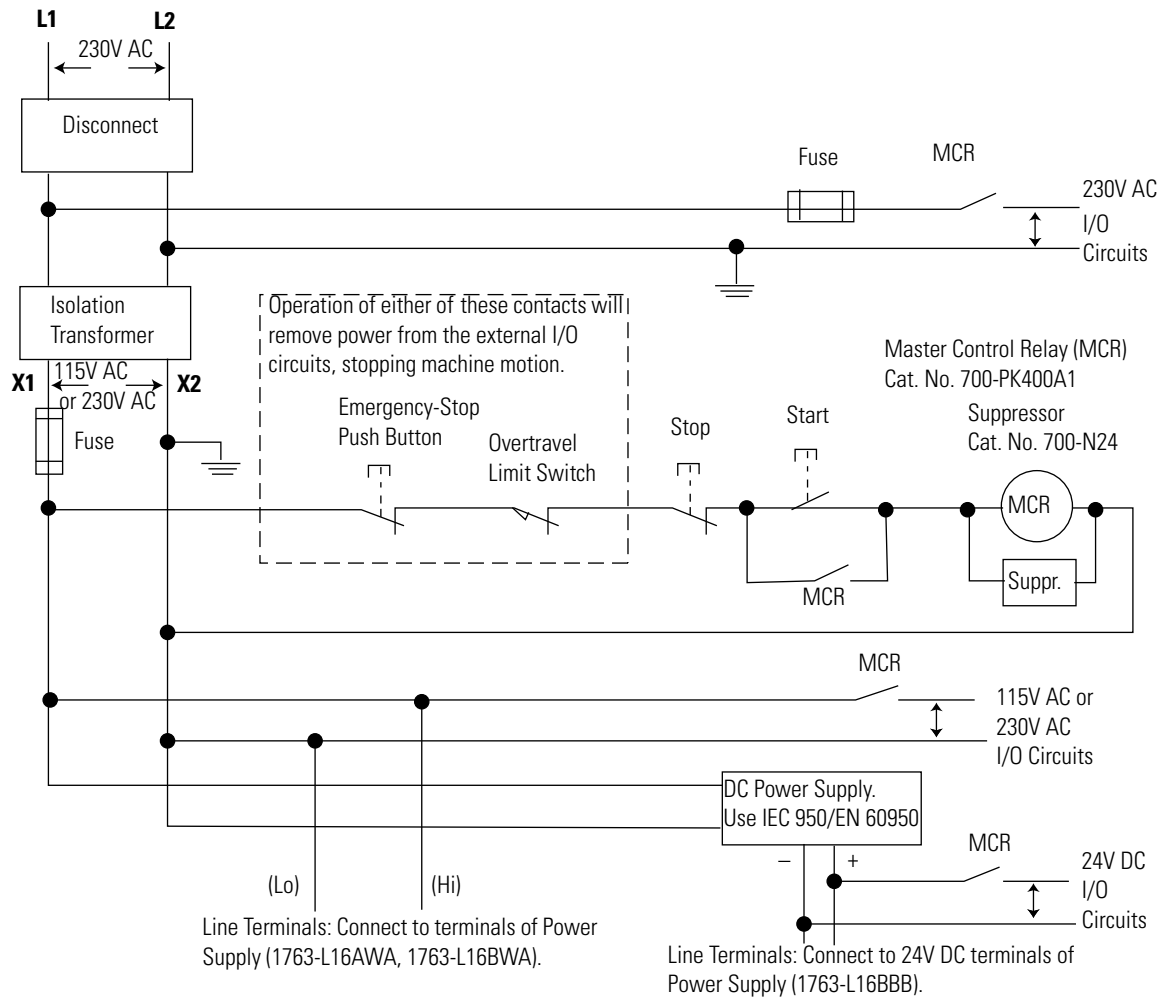

Schematic (Using ANSI/CSA Symbols)

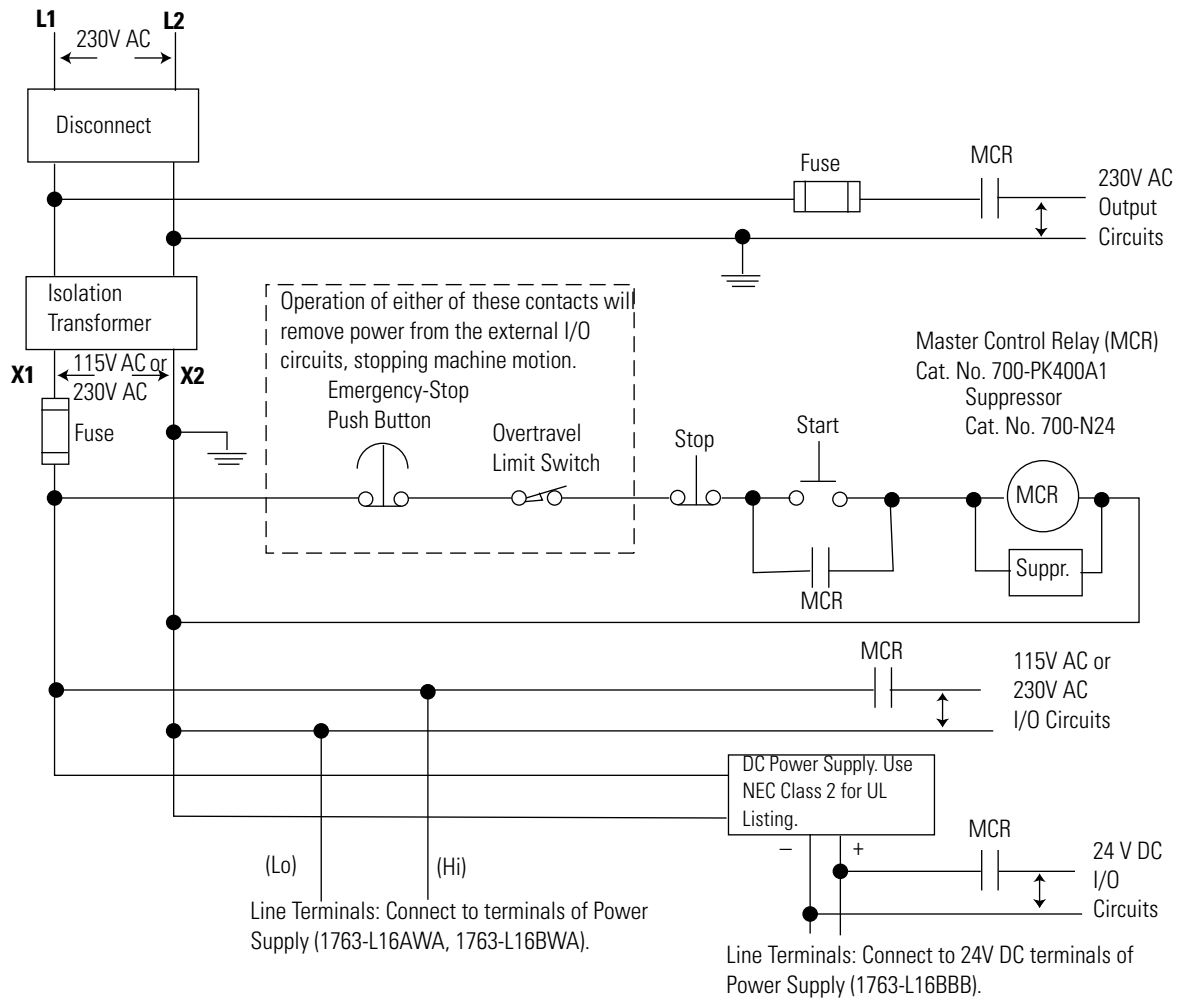

Installing a Memory Module

1. Remove the memory module port cover.

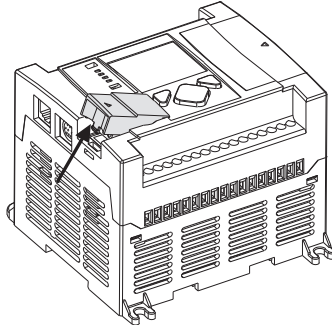

2. Align the connector on the memory module with the connector pins on the controller.

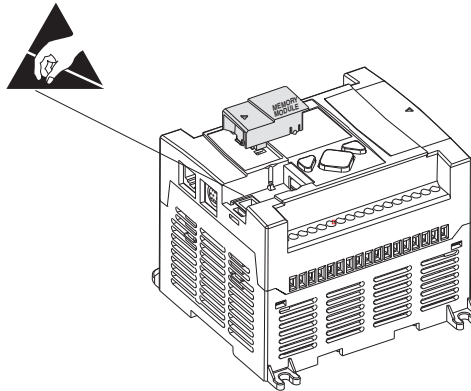

3. Firmly seat the memory module into the controller.

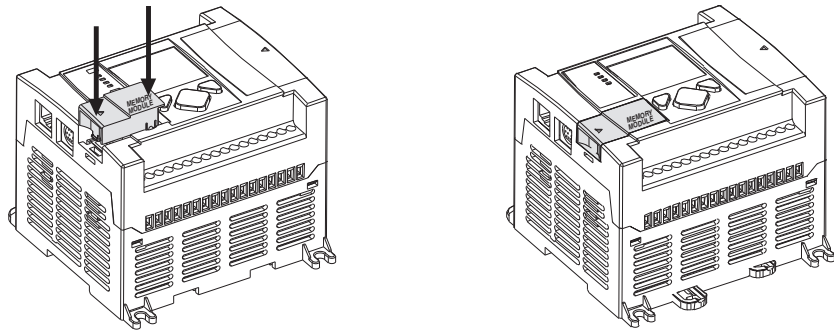

Using the Battery

The MicroLogix 1100 controller is equipped with a replaceable battery. The Battery Low indicator on the LCD display of the controller shows the status of the replaceable battery. When the battery is low, the indicator is set (displayed as a solid rectangle). This means that either the battery wire connector is disconnected, or the battery may fail within 2 weeks if it is connected. When the battery level is acceptable, the indicator is clear (displayed as an empty rectangle).

IMPORTANT

The MicroLogix 1100 controller ships with the battery wire connector connected.

Ensure that the battery wire connector is inserted into the connector port if your application needs battery power. For example, when using a real-time clock (RTC), or to store the program in the controller's memory for an extended period of time while the power is removed.

See *Lithium Battery (1763-BA)* in the *appendix B*, for more information on installation, handling, usage, storage, and disposal of the battery.

See *RTC Battery Operation* on page 140, for more information on the use of the battery in relation with RTC.

IMPORTANT

When the controller's Battery Low indicator is set (displayed as a solid rectangle) with the battery wire connector connected, we recommend strongly to install a new battery immediately.

Connecting the Battery Wire Connector

Follow the procedure below to connect the battery wire connector to the battery connector.

1. Insert the replaceable battery wire connector into the battery connector.
2. Secure the battery connector wires along the wire guide as shown below.

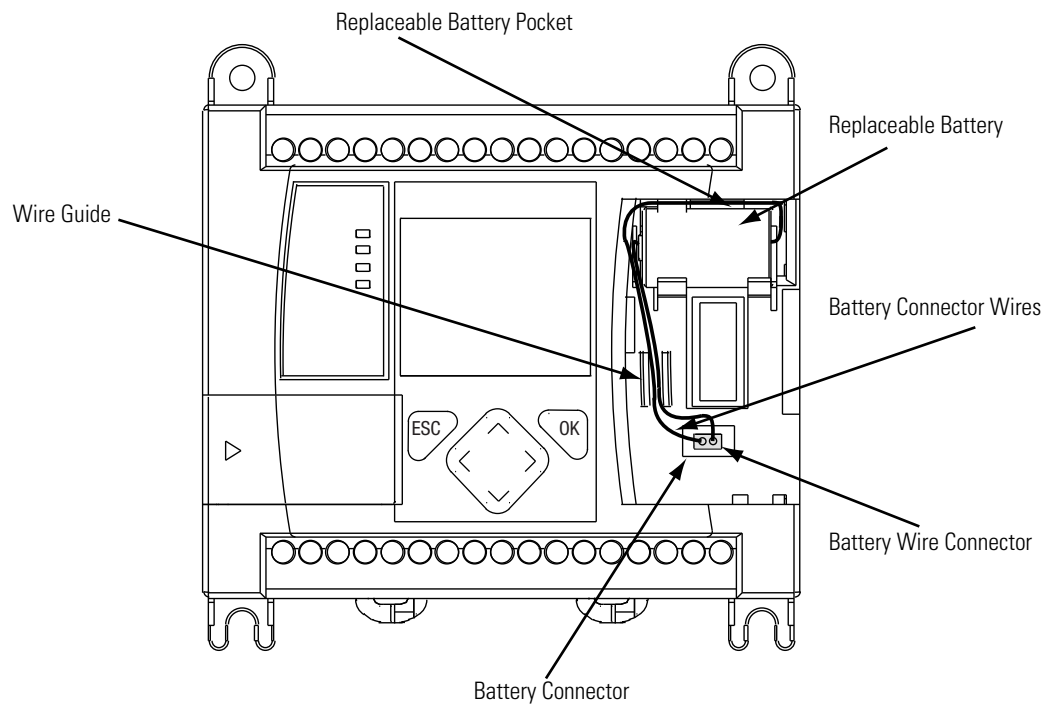

Controller Mounting Dimensions

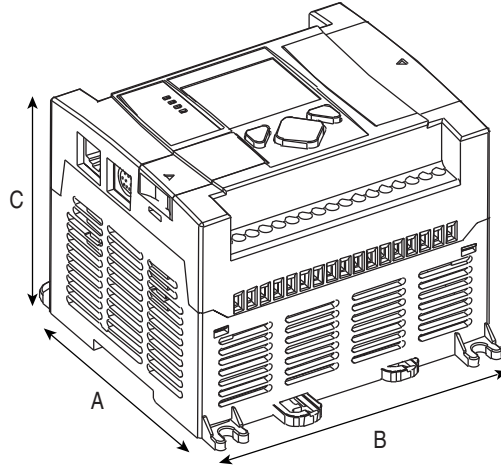

1763-L16AWA, 1763-L16BWA, 1763-L16BBB

Controller Dimensions

Dimension	1763-L16AWA	1763-L16BWA	1763-L16BBB	1763-L16DWD
A	90 mm (3.5 in.)			
B	110 mm (4.33 in.)			
C	87 mm (3.43 in.)			

Controller and Expansion I/O Spacing

The controller mounts horizontally, with the expansion I/O extending to the right of the controller. Allow 50 mm (2 in.) of space on all sides of the controller system for adequate ventilation. Maintain spacing from enclosure walls, wireways, adjacent equipment, etc., as shown below.

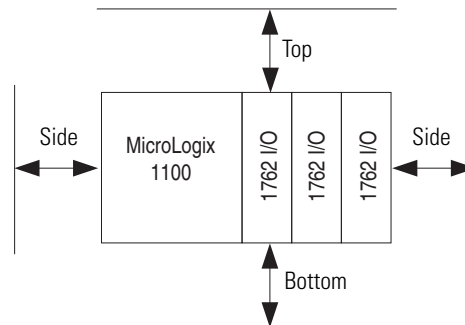

Mounting the Controller

MicroLogix 1100 controllers are suitable for use in an industrial environment when installed in accordance with these instructions. Specifically, this equipment is intended for use in clean, dry environments (Pollution degree 2⁽¹⁾) and to circuits not exceeding Over Voltage Category II⁽²⁾ (IEC 60664-1).⁽³⁾

ATTENTION



Do not remove the protective debris shield until after the controller and all other equipment in the panel near the controller are mounted and wiring is complete. Once wiring is complete, remove protective debris shield. Failure to remove shield before operating can cause overheating.

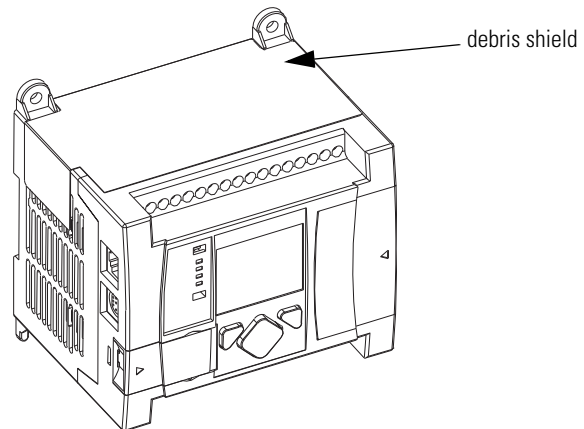

ATTENTION



Electrostatic discharge can damage semiconductor devices inside the controller. Do not touch the connector pins or other sensitive areas.

TIP

For environments with greater vibration and shock concerns, use the panel mounting method described on page 36, rather than DIN rail mounting.

⁽¹⁾ Pollution Degree 2 is an environment where, normally, only non-conductive pollution occurs except that occasionally a temporary conductivity caused by condensation shall be expected.

⁽²⁾ Over Voltage Category II is the load level section of the electrical distribution system. At this level transient voltages are controlled and do not exceed the impulse voltage capability of the product's insulation.

⁽³⁾ Pollution Degree 2 and Over Voltage Category II are International Electrotechnical Commission (IEC) designations.

DIN Rail Mounting

The maximum extension of the latch is 14 mm (0.55 in.) in the open position. A flat-blade screwdriver is required for removal of the controller. The controller can be mounted to EN50022-35x7.5 or EN50022-35x15 DIN rails. DIN rail mounting dimensions are shown below.

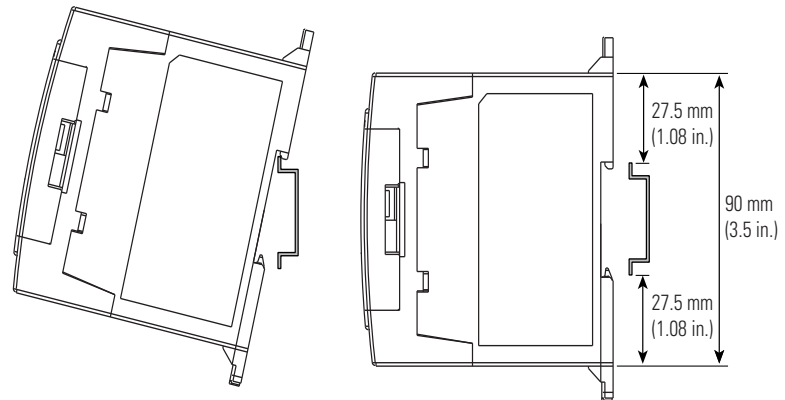

Follow this procedure to install your controller on the DIN rail.

1. Mount your DIN rail. (Make sure that the placement of the controller on the DIN rail meets the recommended spacing requirements, see Controller and Expansion I/O Spacing on page 33. Refer to the mounting template inside the back cover of this document.)
2. Close the DIN latch, if it is open.
3. Hook the top slot over the DIN rail.
4. While pressing the controller down against the top of the rail, snap the bottom of the controller into position.
5. Leave the protective debris shield attached until you are finished wiring the controller and any other devices.

To remove your controller from the DIN rail:

1. Place a flat-blade screwdriver in the DIN rail latch at the bottom of the controller.
2. Holding the controller, pry downward on the latch until the latch locks in the open position.
3. Repeat steps 1 and 2 for the second DIN rail latch.
4. Unhook the top of the DIN rail slot from the rail.

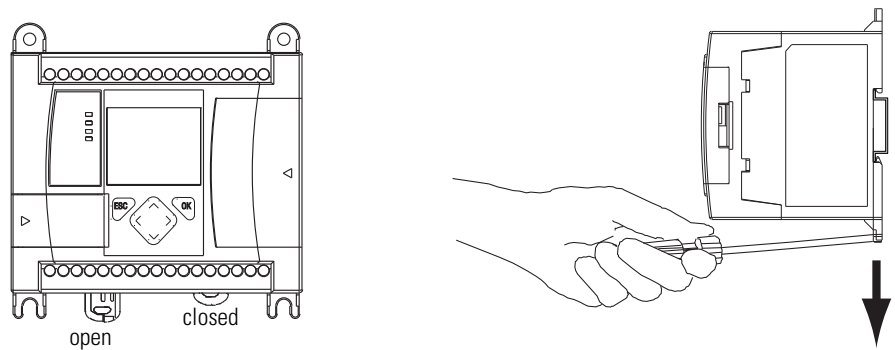

Panel Mounting

Mount to panel using #8 or M4 screws. To install your controller using mounting screws:

1. Remove the mounting template from inside the back cover of the *MicroLogix 1100 Programmable Controllers Installation Instructions*, publication 1763-IN001.
2. Secure the template to the mounting surface. (Make sure your controller is spaced properly. See Controller and Expansion I/O Spacing on page 33.)
3. Drill holes through the template.
4. Remove the mounting template.
5. Mount the controller.
6. Leave the protective debris shield in place until you are finished wiring the controller and any other devices.

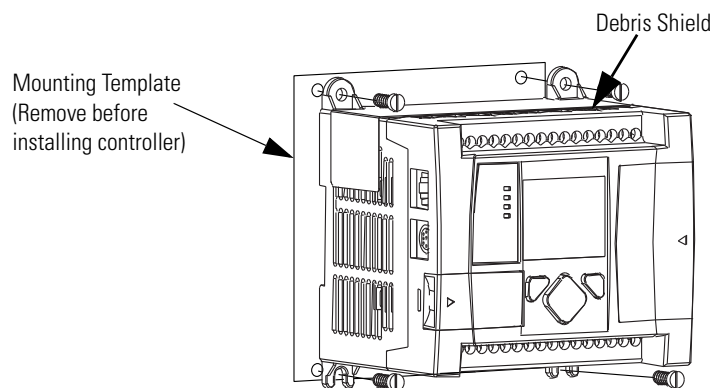

1762 Expansion I/O Dimensions

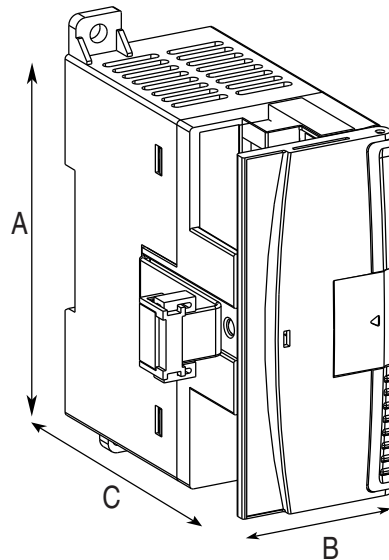

Dimension	Expansion I/O Module
A	90 mm (3.5 in.)
B	40 mm (1.57 in.)
C	87 mm (3.43 in.)

Mounting 1762 Expansion I/O

ATTENTION



During panel or DIN rail mounting of all devices, be sure that all debris (metal chips, wire stands, etc.) is kept from falling into the module. Debris that falls into the module could cause damage when the module is under power.

DIN Rail Mounting

The module can be mounted using the following DIN rails:

- 35 x 7.5 mm (EN 50 022 - 35 x 7.5), or
- 35 x 15 mm (EN 50 022 - 35 x 15).

Before mounting the module on a DIN rail, close the DIN rail latch. Press the DIN rail mounting area of the module against the DIN rail. The latch momentarily opens and locks into place.

Use DIN rail end anchors (Allen-Bradley part number 1492-EA35 or 1492-EAH35) for vibration or shock environments. The following illustration shows the location of the end anchors.

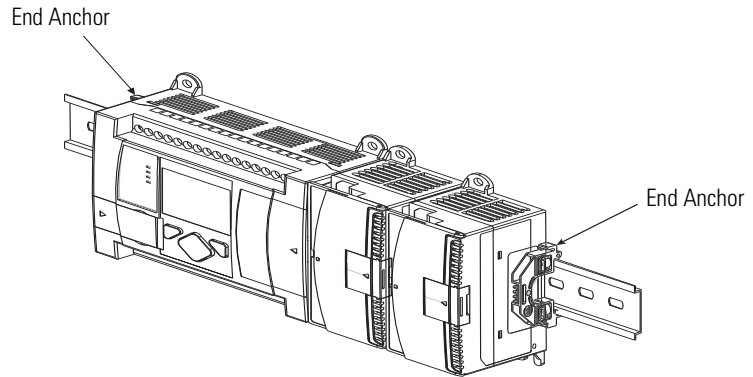

TIP

1762 expansion I/O must be mounted horizontally as illustrated.

TIP

For environments with greater vibration and shock concerns, use the panel mounting method described below, instead of DIN rail mounting.

Panel Mounting

Use the dimensional template shown below to mount the module. The preferred mounting method is to use two M4 or #8 panhead screws per module. Mounting screws are required on every module.

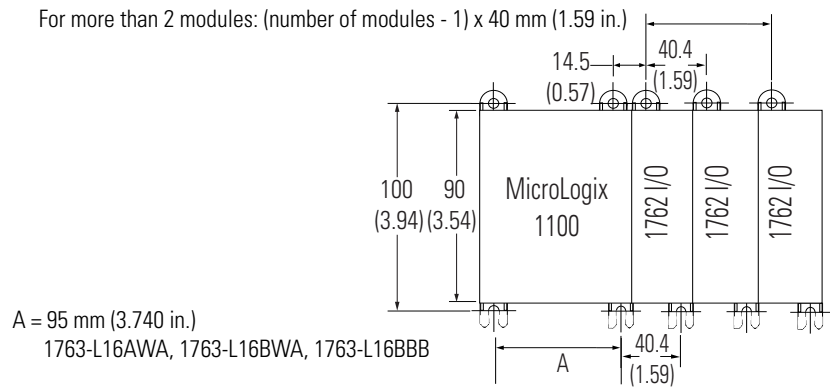

NOTE: All dimensions are in mm (inches).
 Hole spacing tolerance: ±0.4 mm (0.016 in.).

Connecting Expansion I/O

The expansion I/O module is attached to the controller or another I/O module by means of a flat ribbon cable *after* mounting, as shown below.

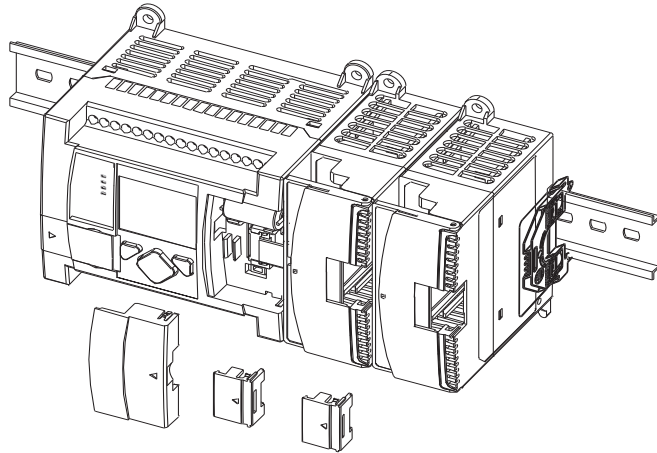

TIP

Use the pull loop on the connector to disconnect modules. Do not pull on the ribbon cable.

TIP

Up to four expansion I/O modules can be connected to a controller.

ATTENTION



Remove power before removing or inserting an I/O module. When you remove or insert a module with power applied, an electrical arc may occur. An electrical arc can cause personal injury or property damage by:

- sending an erroneous signal to your system's field devices, causing the controller to fault
- causing an explosion in a hazardous environment

Electrical arcing causes excessive wear to contacts on both the module and its mating connector. Worn contacts may create electrical resistance, reducing product reliability.

WARNING



EXPLOSION HAZARD

In Class I, Division 2 applications, the bus connector must be fully seated and the bus connector cover must be snapped in place.

In Class I, Division 2 applications, all modules must be mounted in direct contact with each other as shown on page 39. If DIN rail mounting is used, an end stop must be installed ahead of the controller and after the last 1762 I/O module.

Notes:

Wiring Your Controller

This chapter describes how to wire your controller and expansion I/O. Topics include:

- wire requirements
- using surge suppressors
- grounding the controller
- wiring diagrams
- sinking and sourcing wiring diagrams
- controller I/O wiring
- wiring your analog channels
- expansion I/O wiring

Wiring Requirements

Wiring Recommendation

ATTENTION

Before you install and wire any device, disconnect power to the controller system.

ATTENTION

Calculate the maximum possible current in each power and common wire. Observe all electrical codes dictating the maximum current allowable for each wire size. Current above the maximum ratings may cause wiring to overheat, which can cause damage.

United States Only: If the controller is installed within a potentially hazardous environment, all wiring must comply with the requirements stated in the National Electrical Code 501-10 (b).

-
- Allow for at least 50 mm. (2 in.) between I/O wiring ducts or terminal strips and the controller.
 - Route incoming power to the controller by a path separate from the device wiring. Where paths must cross, their intersection should be perpendicular.

TIP

Do not run signal or communications wiring and power wiring in the same conduit. Wires with different signal characteristics should be routed by separate paths.

- Separate wiring by signal type. Bundle wiring with similar electrical characteristics together.
- Separate input wiring from output wiring.
- Label wiring to all devices in the system. Use tape, shrink-tubing, or other dependable means for labeling purposes. In addition to labeling, use colored insulation to identify wiring based on signal characteristics. For example, you may use blue for DC wiring and red for AC wiring.

Wire Requirements

Wire Type		Wire Size (2 wire maximum per terminal screw)	
		1 wire per terminal	2 wire per terminal
Solid	Cu-90°C (194°F)	#12 to #20 AWG	#16 to #20 AWG
Stranded	Cu-90°C (194°F)	#14 to #20 AWG	#18 to #20 AWG

Wiring torque = 0.56 Nm (5.0 in-lb) rated

Wiring the Terminal Block

The MicroLogix 1100 controllers have screw-cage clamps on the input and output terminal blocks. With screw-cage clamp terminal blocks, there is no need to attach additional hardware such as a spade lug to the wire, or use a finger-safe cover.

To wire the terminal block:

1. Strip the end of the wire.

The recommended length for the stripped end of the wire is 11.0 mm (0.440 in.).

2. Insert it into an open clamp.
3. Using a small, flat-blade screwdriver, tighten the terminal screw. To ensure that the wire conductor is secured inside the clamp, tighten it to the rated torque, 0.56 Nm (5.0 in-lb).

The diameter of the terminal screw head is 5.5 mm (0.220 in.).

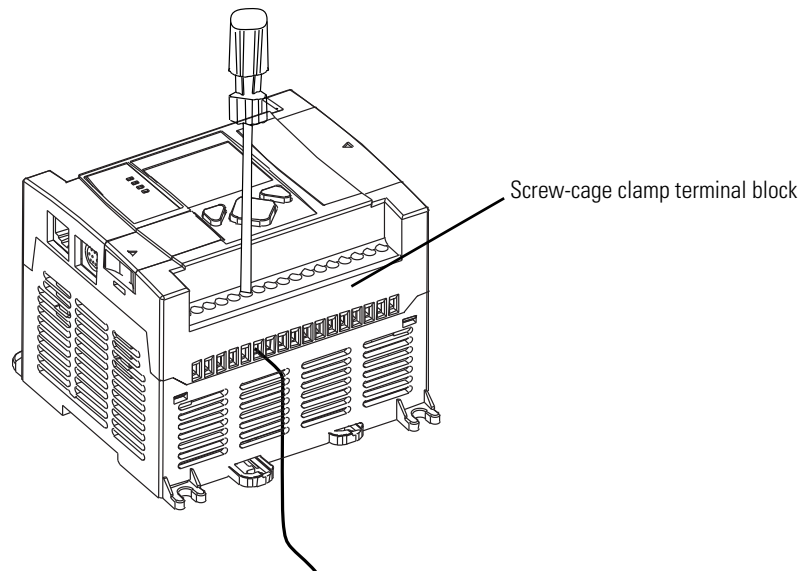

Using Surge Suppressors

Because of the potentially high current surges that occur when switching inductive load devices, such as motor starters and solenoids, the use of some type of surge suppression to protect and extend the operating life of the controller's output contacts is required. Switching inductive loads without surge suppression can *significantly* reduce the life expectancy of relay contacts. By adding a suppression device directly across the coil of an inductive device, you prolong the life of the output or relay contacts. You also reduce the effects of voltage transients and electrical noise from radiating into adjacent systems.

The following diagram shows an output with a suppression device. We recommend that you locate the suppression device as close as possible to the load device.

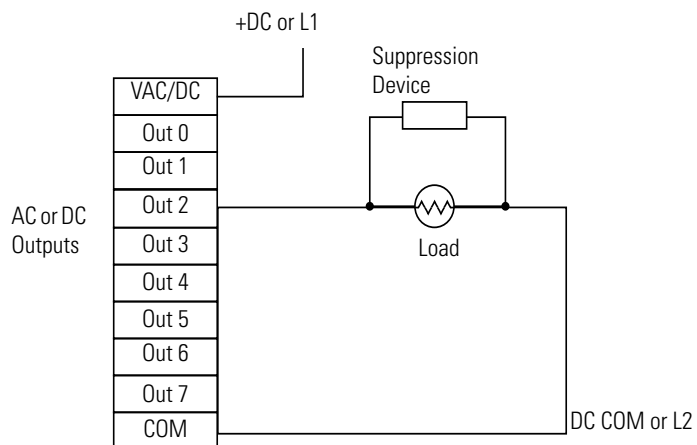

If the outputs are DC, we recommend that you use a 1N4004 diode for surge suppression, as shown below. For inductive DC load devices, a diode is suitable. A 1N4004 diode is acceptable for most applications. A surge

suppressor can also be used. See for recommended suppressors. As shown below, these surge suppression circuits connect directly across the load device.

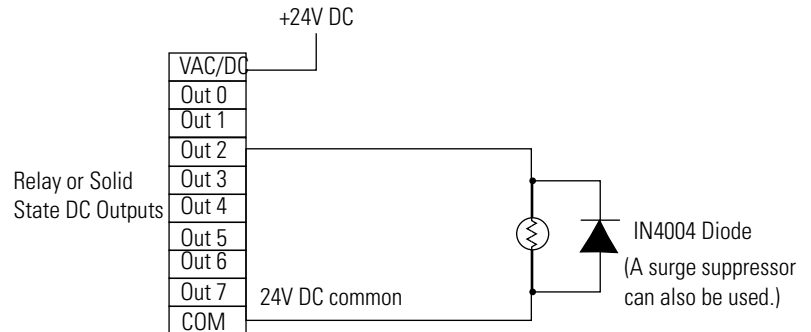

Suitable surge suppression methods for inductive AC load devices include a varistor, an RC network, or an Allen-Bradley surge suppressor, all shown below. These components must be appropriately rated to suppress the switching transient characteristic of the particular inductive device. See the table on 45 for recommended suppressors.

Surge Suppression for Inductive AC Load Devices

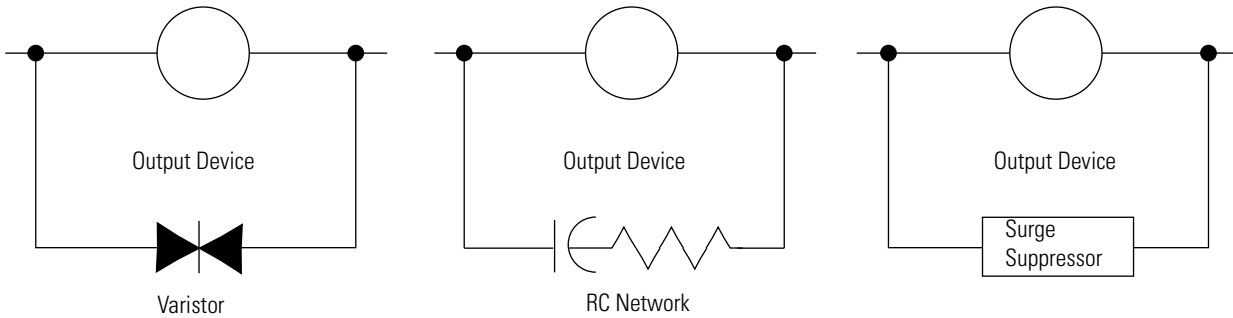

Recommended Surge Suppressors

Use the Allen-Bradley surge suppressors shown in the following table for use with relays, contactors, and starters.

Recommended Surge Suppressors

Device	Coil Voltage	Suppressor Catalog Number
Bulletin 509 Motor Starter Bulletin 509 Motor Starter	120V AC 240V AC	599-K04 ⁽¹⁾ 599-KA04 ⁽¹⁾
Bulletin 100 Contactor Bulletin 100 Contactor	120V AC 240V AC	199-FSMA1 ⁽²⁾ 199-FSMA2 ⁽²⁾
Bulletin 709 Motor Starter	120V AC	1401-N10 ⁽²⁾
Bulletin 700 Type R, RM Relays	AC coil	None Required
Bulletin 700 Type R Relay Bulletin 700 Type RM Relay	12V DC 12V DC	199-FSMA9
Bulletin 700 Type R Relay Bulletin 700 Type RM Relay	24V DC 24V DC	199-FSMA9
Bulletin 700 Type R Relay Bulletin 700 Type RM Relay	48V DC 48V DC	199-FSMA9
Bulletin 700 Type R Relay Bulletin 700 Type RM Relay	115-125V DC 115-125V DC	199-FSMA10
Bulletin 700 Type R Relay Bulletin 700 Type RM Relay	230-250V DC 230-250V DC	199-FSMA11
Bulletin 700 Type N, P, or PK Relay	150V max, AC or DC	700-N24 ⁽²⁾
Miscellaneous electromagnetic devices limited to 35 sealed VA	150V max, AC or DC	700-N24 ⁽²⁾

⁽¹⁾ Varistor – Not recommended for use on relay outputs.

⁽²⁾ RC Type – Do not use with Triac outputs.

Grounding the Controller

In solid-state control systems, grounding and wire routing helps limit the effects of noise due to electromagnetic interference (EMI). Run the ground connection from the ground screw of the controller to the ground bus prior to connecting any devices. Use AWG #14 wire. For AC-powered controllers, this connection must be made for safety purposes.

ATTENTION



All devices connected to the RS-232/485 communication port must be referenced to controller ground, or be floating (not referenced to a potential other than ground). Failure to follow this procedure may result in property damage or personal injury.

- For 1763-L16BWA controllers, the COM of the sensor supply is also connected to chassis ground internally. The 24V DC sensor power source should not be used to power output circuits. It should only be used to power input devices.
- For 1763-L16BBB and 1763-L16DWD controllers, the VDC NEUT or common terminal of the power supply is also connected to chassis ground internally.

This product is intended to be mounted to a well grounded mounting surface such as a metal panel. Refer to the *Industrial Automation Wiring and Grounding Guidelines*, publication 1770-4.1, for additional information. Additional grounding connections from the mounting tab or DIN rail, if used, are not required unless the mounting surface cannot be grounded.

TIP

Use all four mounting positions for panel mounting installation.

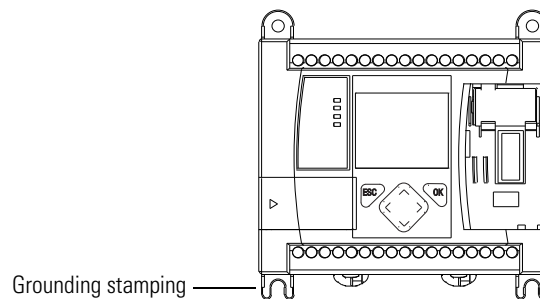

ATTENTION



Remove the protective debris strip before applying power to the controller. Failure to remove the strip may cause the controller to overheat.

Wiring Diagrams

The following illustrations show the wiring diagrams for the MicroLogix 1100 controllers. Controllers with DC inputs can be wired as either sinking or sourcing inputs. (Sinking and sourcing does not apply to AC inputs.) Refer to Sinking and Sourcing Wiring Diagrams on page 3-50.

The controller terminal block layouts are shown below. The shading on the labels indicates how the terminals are grouped. A detail of the groupings is shown in the table following the terminal block layouts.

TIP

This  symbol denotes a protective earth ground terminal which provides a low impedance path between electrical circuits and earth for safety purposes and provides noise immunity improvement. This connection must be made for safety purposes on AC-powered controllers.

This  symbol denotes a functional earth ground terminal which provides a low impedance path between electrical circuits and earth for non-safety purposes, such as noise immunity improvement.

Terminal Block Layouts

1763-L16AWA

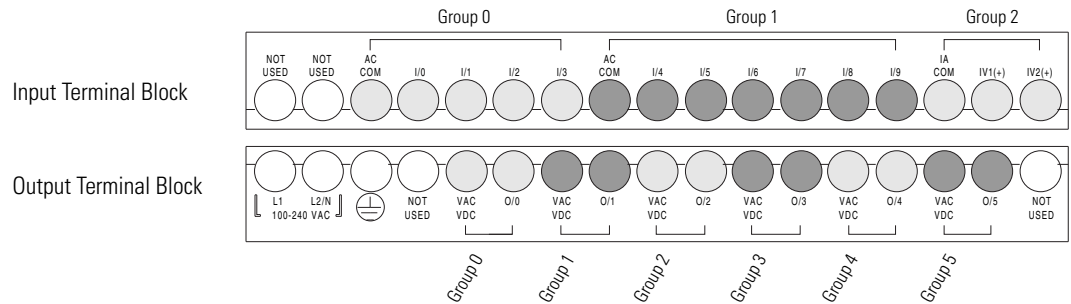

1763-L16BWA

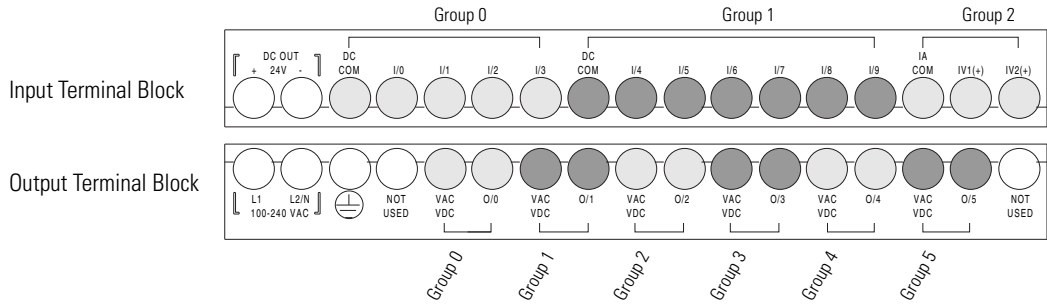

ATTENTION The 24V DC sensor supply of the 1763-L16BWA should not be used to power output circuits. It should only be used to power input devices (e.g. sensors, switches). See Master Control Relay on page 2-26 for information on MCR wiring in output circuits.



1763-L16BBB

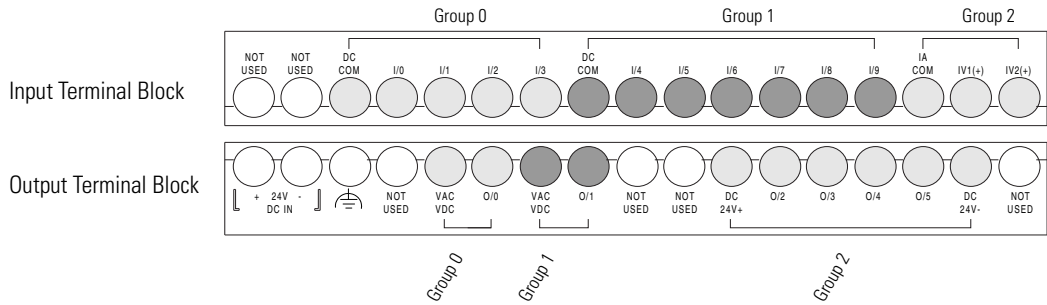

1763-L16DWD

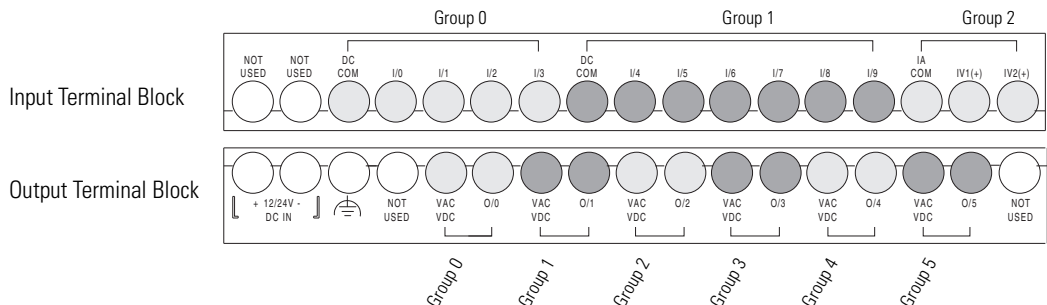

Terminal Groupings

Input Terminal Grouping

Controller	Inputs		
	Input Group	Common Terminal	Input Terminal
1763-L16AWA	Group 0	AC COM 0	I/0 through I/3
	Group 1	AC COM 1	I/4 through I/9
	Group 2	IA COM	IV1(+) and IV2(+)
1763-L16BWA	Group 0	DC COM 0	I/0 through I/3
	Group 1	DC COM 1	I/4 through I/9
	Group 2	IA COM	IV1(+) and IV2(+)
1763-L16BBB	Group 0	DC COM 0	I/0 through I/3
1763-L16DWD	Group 1	DC COM 1	I/4 through I/9
	Group 2	IA COM	IV1(+) and IV2(+)

Output Terminal Grouping

Controller	Outputs			
	Output Group	Voltage Terminal	Output Terminal	Description
1763-L16AWA 1763-L16BWA 1763-L16DWD	Group 0	VAC/VDC	O/0	Isolated Relay output
	Group 1	VAC/VDC	O/1	Isolated Relay output
	Group 2	VAC/VDC	O/2	Isolated Relay output
	Group 3	VAC/VDC	O/3	Isolated Relay output
	Group 4	VAC/VDC	O/4	Isolated Relay output
	Group 5	VAC/VDC	O/5	Isolated Relay output
1763-L16BBB	Group 0	VAC/VDC	O/0	Isolated Relay output
	Group 1	VAC/VDC	O/1	Isolated Relay output
	Group 2	DC +24V, DC -24V	O/2 through O/5	FET output

Sinking and Sourcing Wiring Diagrams

Any of the MicroLogix 1100 DC embedded input groups can be configured as sinking or sourcing depending on how the DC COM is wired on the group. Refer to pages 51 through 51 for sinking and sourcing wiring diagrams.

Type	Definition
Sinking Input	The input energizes when high-level voltage is applied to the input terminal (active high). Connect the power supply VDC (-) to the input group's COM terminal.
Sourcing Input	The input energizes when low-level voltage is applied to the input terminal (active low). Connect the power supply VDC (+) to the input group's COM terminal.

ATTENTION



The 24V DC sensor power source must not be used to power output circuits. It should only be used to power input devices (e.g. sensors, switches). See Master Control Relay on page 2-26 for information on MCR wiring in output circuits.

1763-L16AWA, 1763-L16BWA, 1763-L16BBB and 1763-L16DWD Wiring Diagrams

TIP

In the following diagrams, lower case alphabetic subscripts are appended to common-terminal connections to indicate that different power sources may be used for different isolated groups, if desired.

1763-L16AWA Input Wiring Diagram ⁽¹⁾

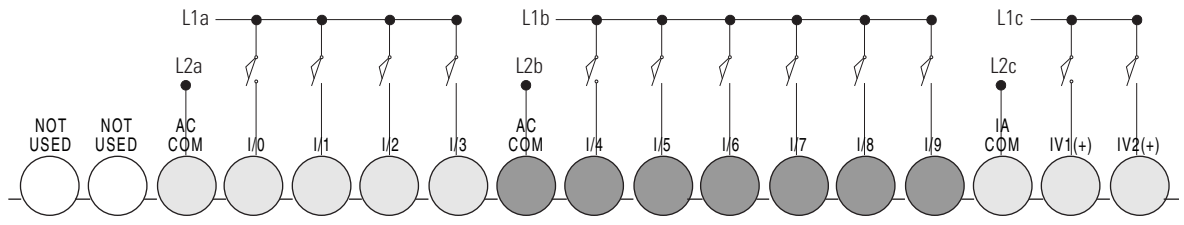

(1) "NOT USED" terminals are not intended for use as connection points.

1763-L16BWA Sinking Input Wiring Diagram

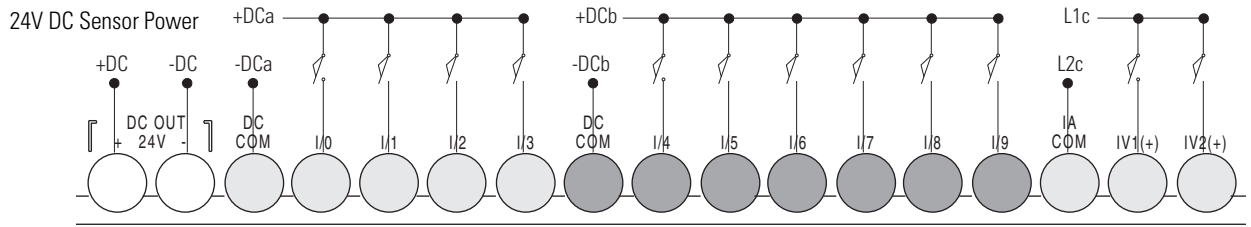

1763-L16BWA Sourcing Input Wiring Diagram

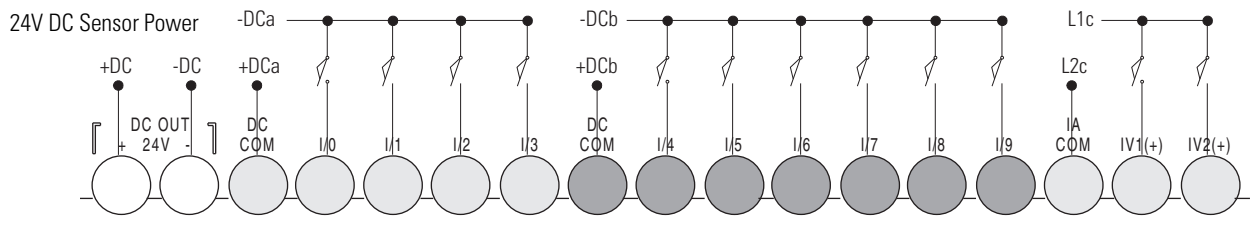

1763-L16BBB and 1763-L16DWD Sinking Input Wiring Diagram

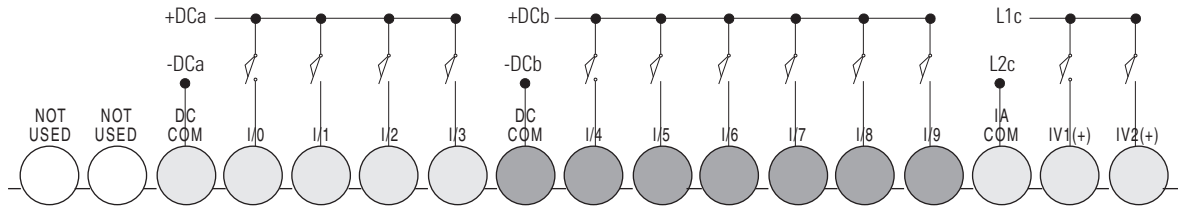

1763-L16BBB and 1763-L16DWD Sourcing Input Wiring Diagram

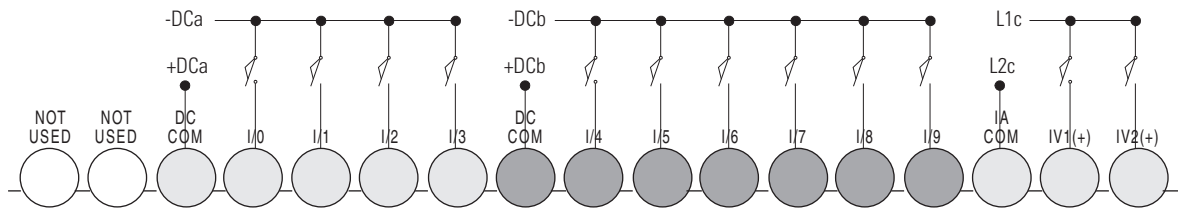

1763-L16AWA and 1763-L16BWA Output Wiring Diagram

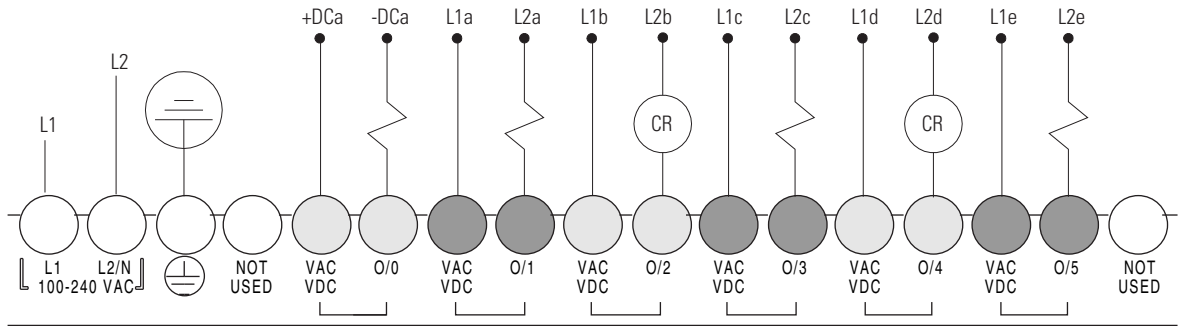

1763-L16BBB Output Wiring Diagram

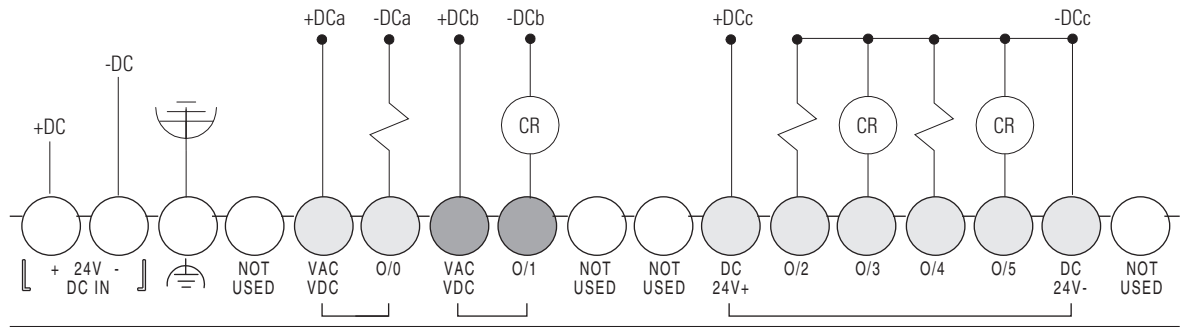

1763-L16DWD Output Wiring Diagram

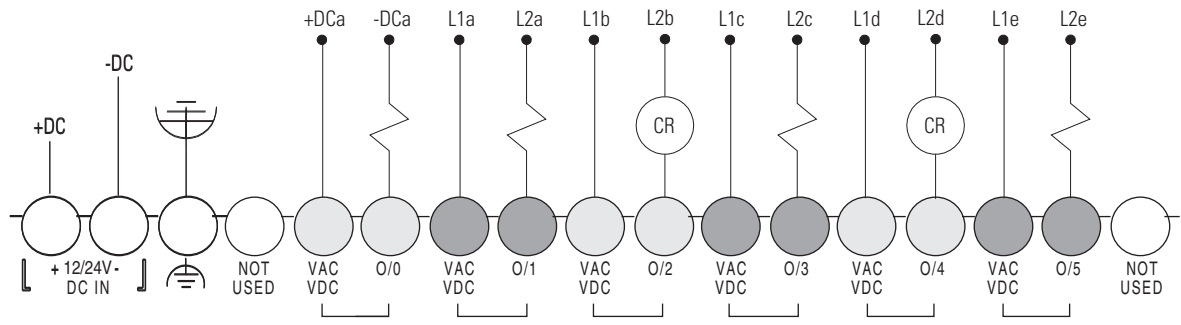

Controller I/O Wiring

Minimizing Electrical Noise

Because of the variety of applications and environments where controllers are installed and operating, it is impossible to ensure that all environmental noise will be removed by input filters. To help reduce the effects of environmental noise, install the MicroLogix 1100 system in a properly rated (for example, NEMA) enclosure. Make sure that the MicroLogix 1100 system is properly grounded.

A system may malfunction due to a change in the operating environment after a period of time. We recommend periodically checking system operation, particularly when new machinery or other noise sources are installed near the MicroLogix 1100 system.

Wiring Your Analog Channels

Analog input circuits can monitor voltage signals and convert them to serial digital data.

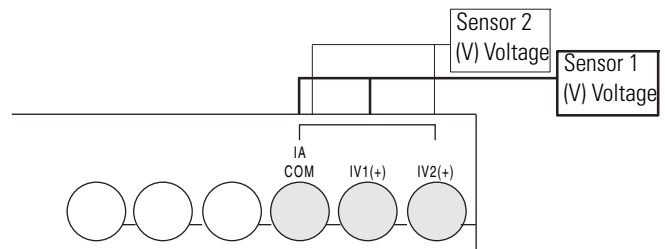

Analog Channel Wiring Guidelines

Consider the following when wiring your analog channels:

- The analog common (COM) is connected to earth ground inside the module. These terminals are not electrically isolated from the system. They are connected to chassis ground.
- Analog channels are not isolated from each other.
- Use Belden™ 8761, or equivalent, shielded wire.
- Under normal conditions, the drain wire (shield) should be connected to the metal mounting panel (earth ground). Keep the shield connection to earth ground as short as possible.
- To ensure optimum accuracy for voltage type inputs, limit overall cable impedance by keeping all analog cables as short as possible. Locate the I/O system as close to your voltage type sensors or actuators as possible.

- The controller does not provide loop power for analog inputs. Use a power supply that matches the transmitter specifications as shown below.

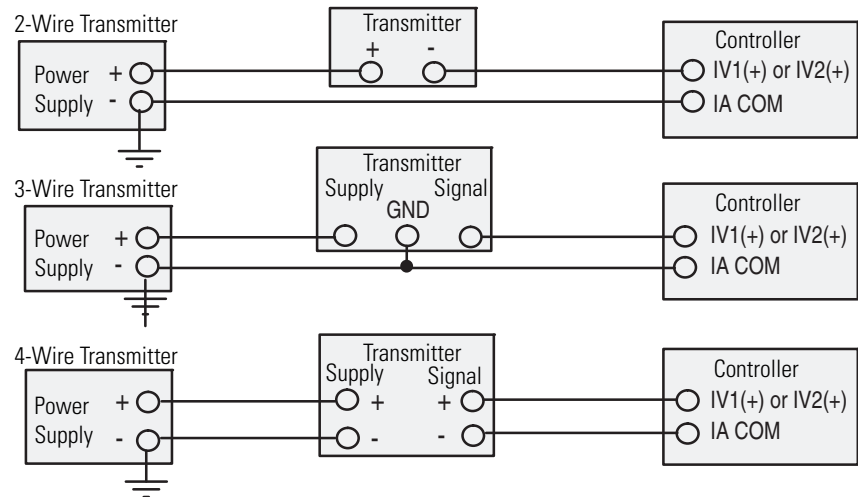

Minimizing Electrical Noise on Analog Channels

Inputs on analog channels employ digital high-frequency filters that significantly reduce the effects of electrical noise on input signals. However, because of the variety of applications and environments where analog controllers are installed and operated, it is impossible to ensure that all environmental noise will be removed by the input filters.

Several specific steps can be taken to help reduce the effects of environmental noise on analog signals:

- install the MicroLogix 1100 system in a properly rated (i.e., NEMA) enclosure. Make sure that the MicroLogix 1100 system is properly grounded.
- use Belden cable #8761 for wiring the analog channels, making sure that the drain wire and foil shield are properly earth grounded.
- route the Belden cable separately from any AC wiring. Additional noise immunity can be obtained by routing the cables in grounded conduit.

Grounding Your Analog Cable

Use shielded communication cable (Belden #8761). The Belden cable has two signal wires (black and clear), one drain wire, and a foil shield. The drain wire and foil shield must be grounded at one end of the cable.

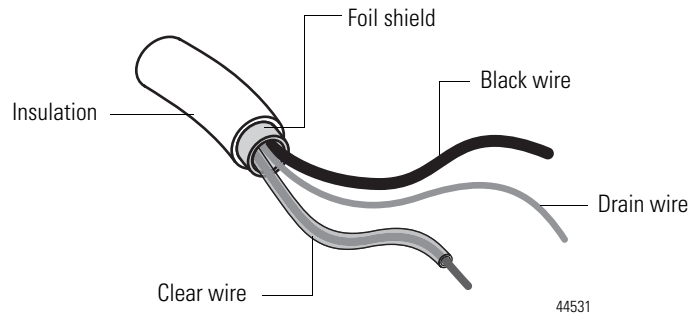

IMPORTANT

Do not ground the drain wire and foil shield at both ends of the cable

Expansion I/O Wiring

Digital Wiring Diagrams

The following illustrations show the digital expansion I/O wiring diagrams.

1762-IA8 Wiring Diagram

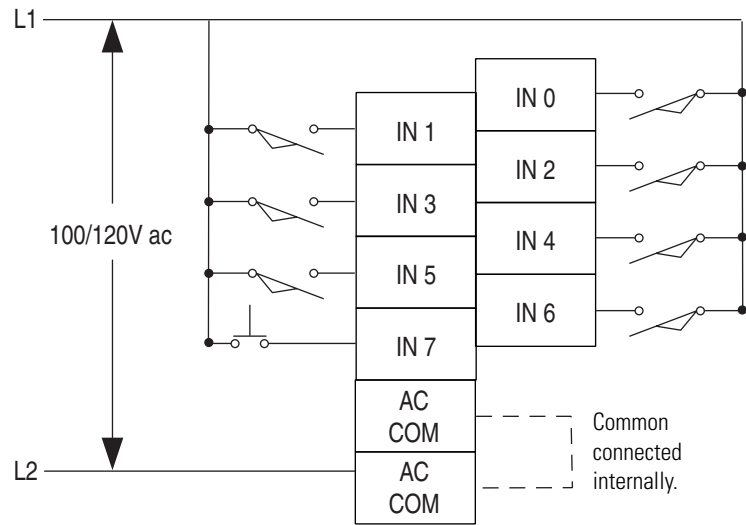

1762-IQ8 Wiring Diagram

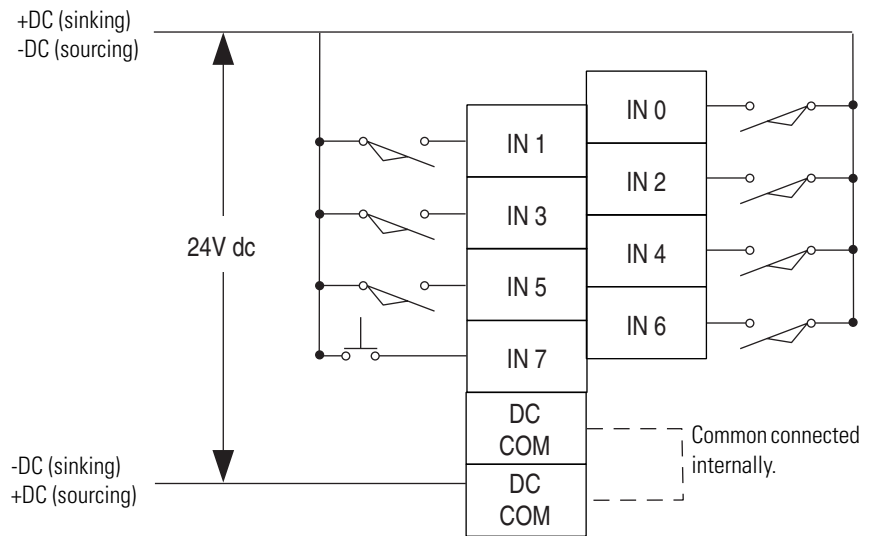

1762-IQ16 Wiring Diagram

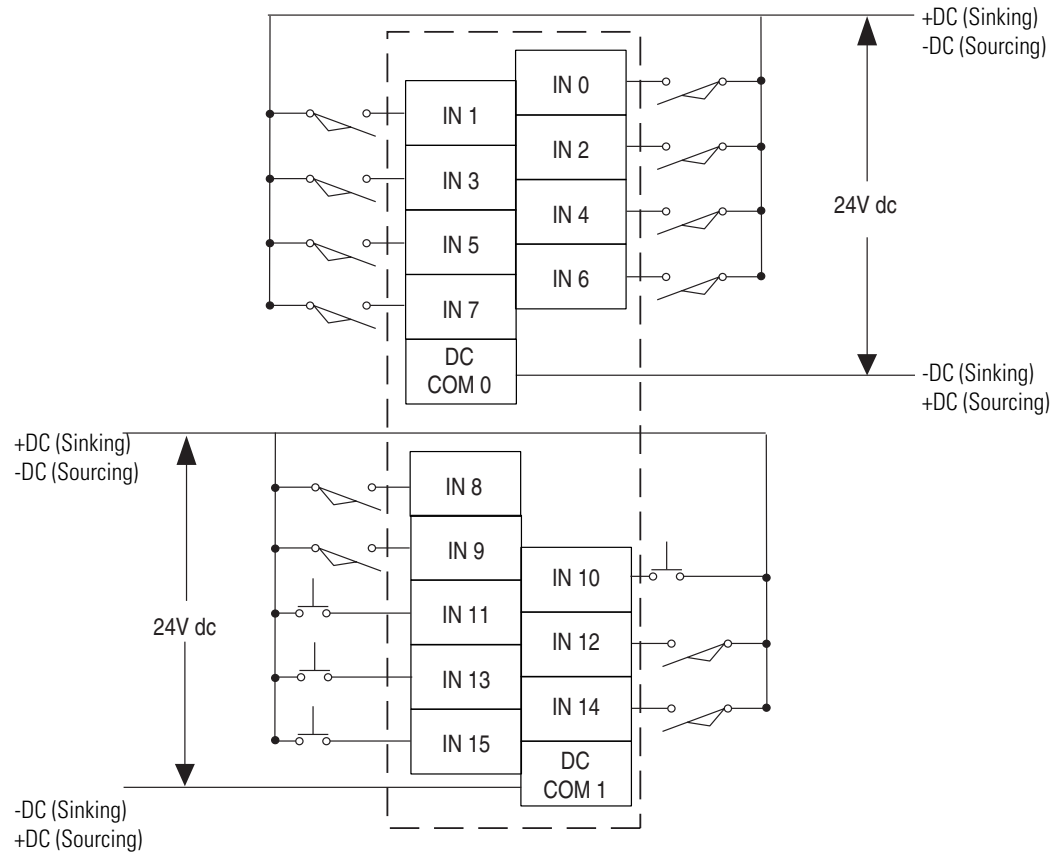

1762-IQ32T Wiring Diagram

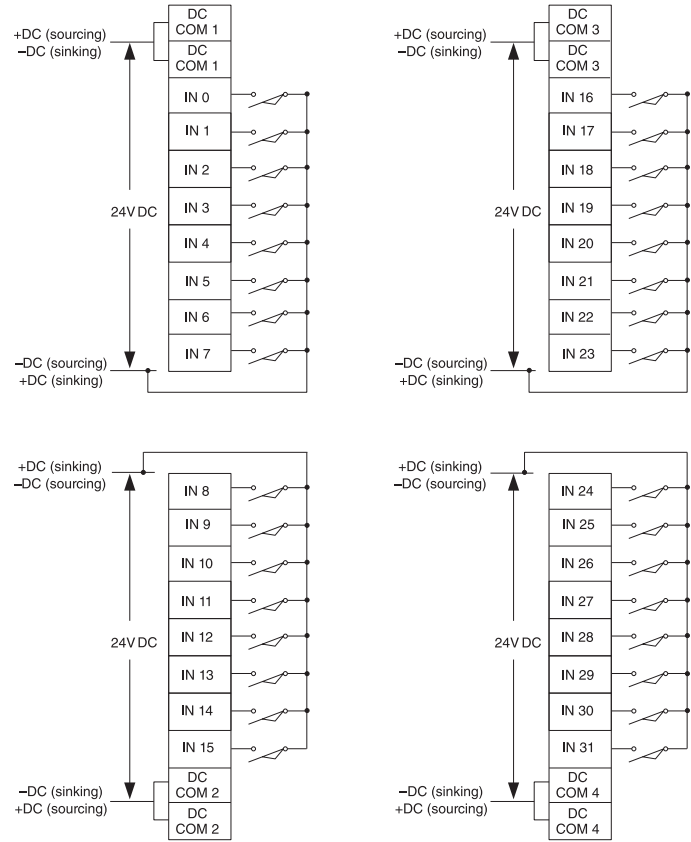

44920

1762-OA8 Wiring Diagram

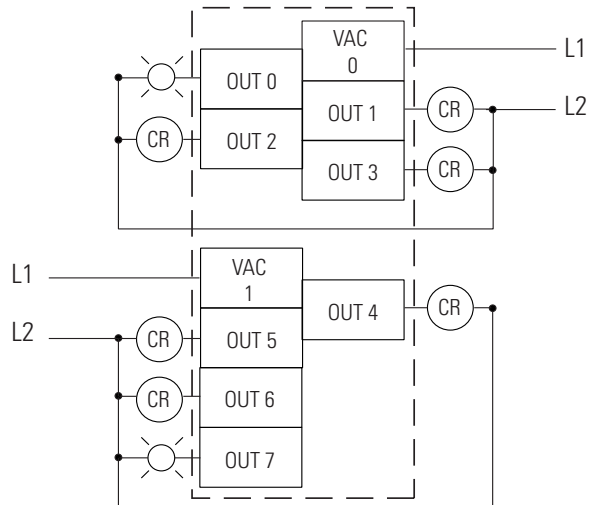

1762-OB8 Wiring Diagram

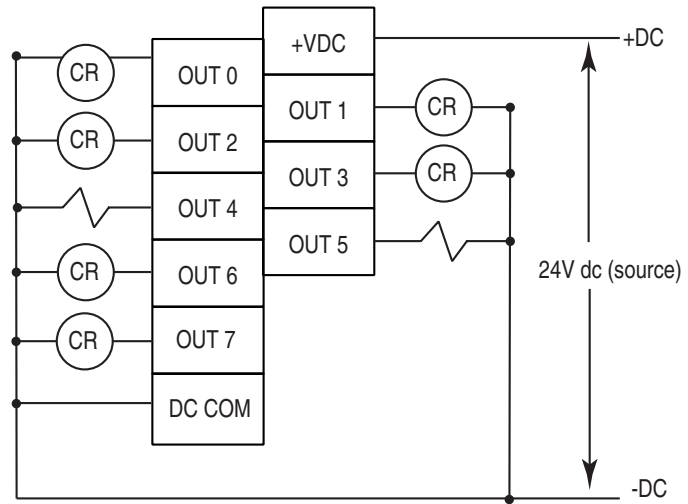

1762-OB16 Wiring Diagram

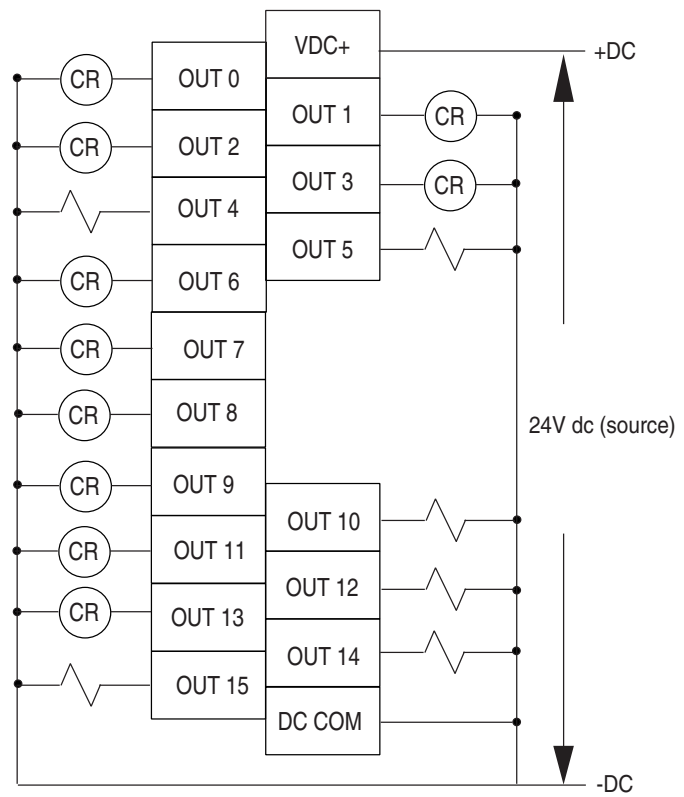

1762-OB32T Wiring Diagram

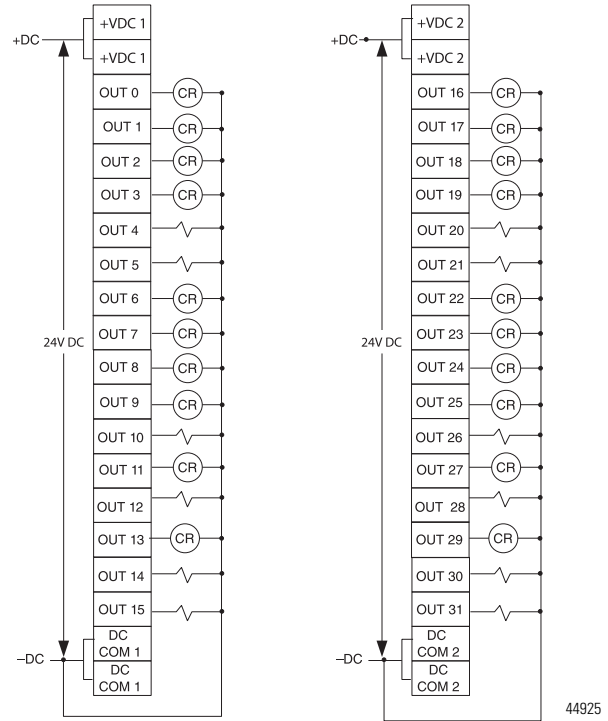

1762-OV32T Wiring Diagram

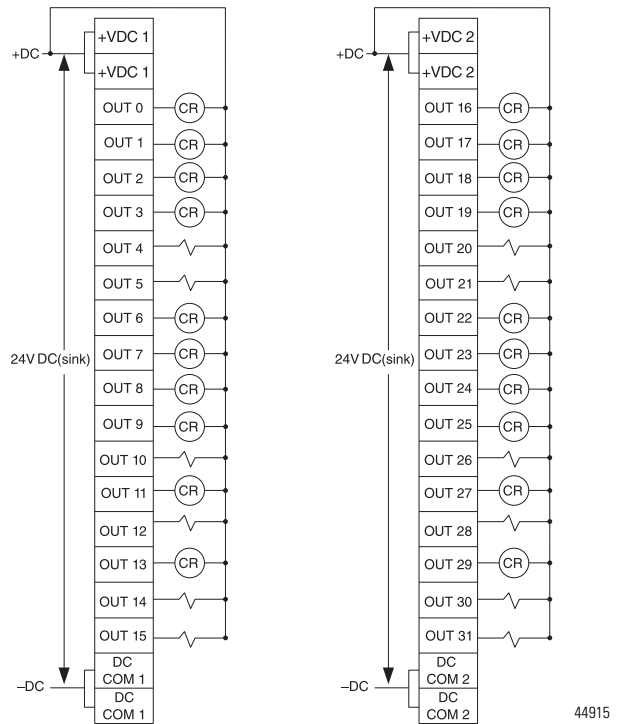

1762-OW8 Wiring Diagram

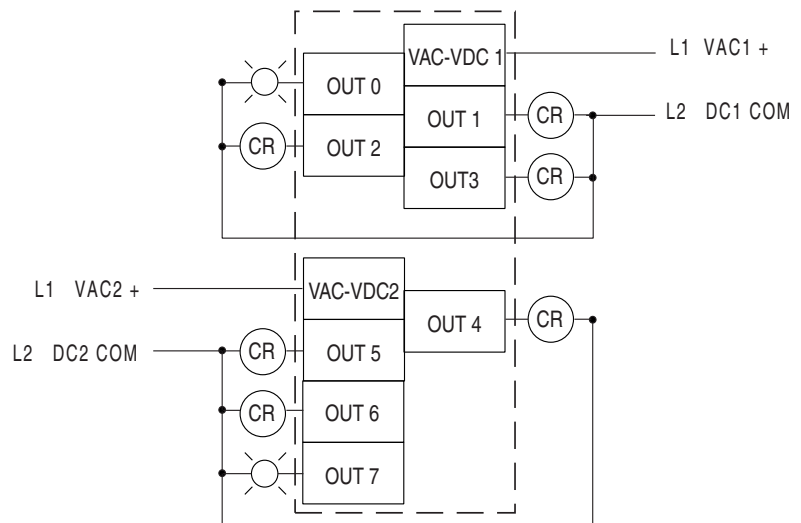

1762-OW16 Wiring Diagram

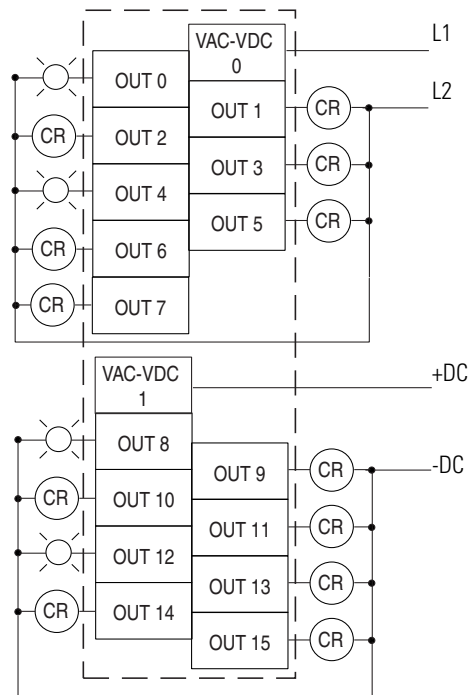

1762-OX6I Wiring Diagram

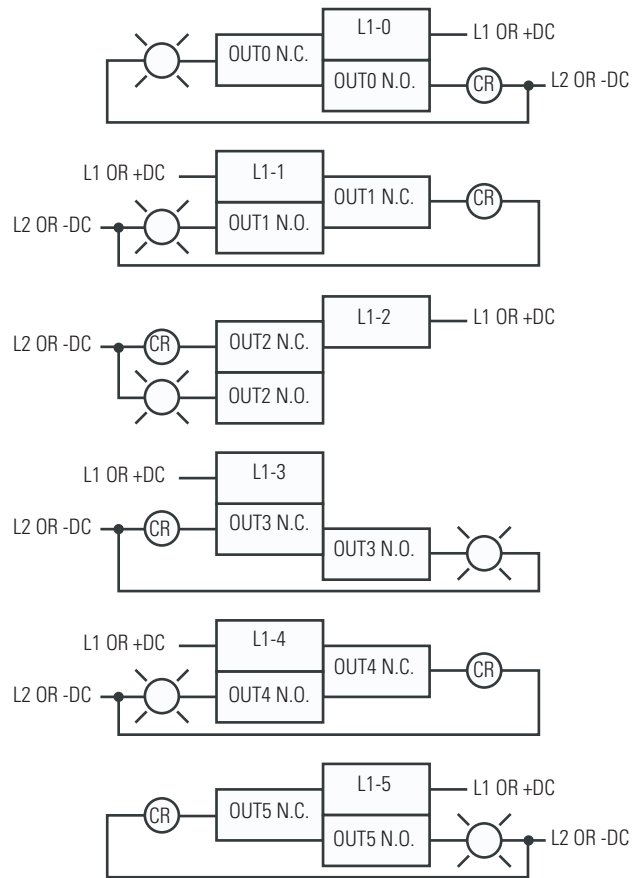

1762-IQ80W6 Wiring Diagram

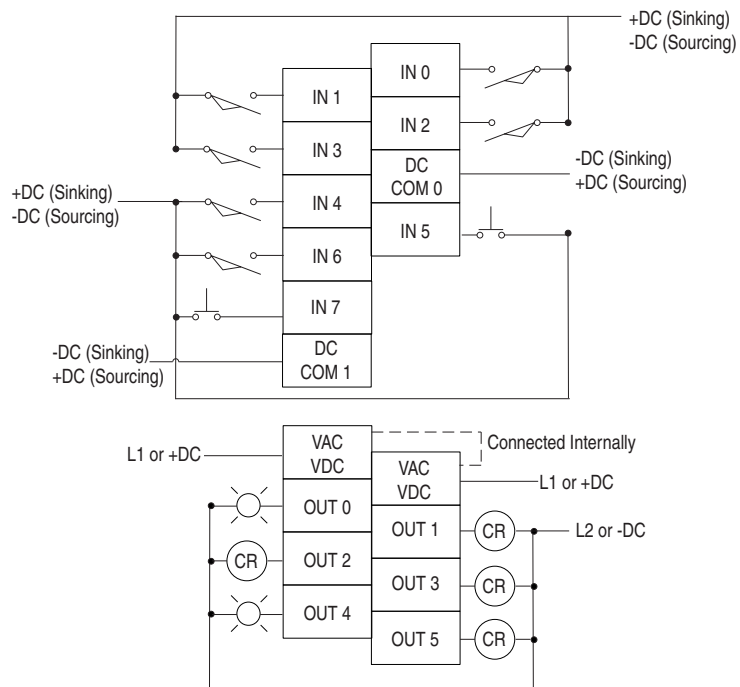

Analog Wiring

Consider the following when wiring your analog modules:

- The analog common (COM) is not connected to earth ground inside the module. All terminals are electrically isolated from the system.
- Channels are not isolated from each other.
- Use Belden 8761, or equivalent, shielded wire.
- Under normal conditions, the drain wire (shield) should be connected to the metal mounting panel (earth ground). Keep the shield connection to earth ground as short as possible.
- To ensure optimum accuracy for voltage type inputs, limit overall cable impedance by keeping all analog cables as short as possible. Locate the I/O system as close to your voltage type sensors or actuators as possible.
- The module does not provide loop power for analog inputs. Use a power supply that matches the input transmitter specifications.

1762-IF2OF2 Input Type Selection

Select the input type, current or voltage, using the switches located on the module's circuit board *and* the input type/range selection bits in the Configuration Data File. Refer to MicroLogix 1100 Programmable Controllers Instruction Set Reference Manual, publication 1763-RM001. You can access the switches through the ventilation slots on the top of the module. Switch 1 controls channel 0; switch 2 controls channel 1. The factory default setting for both switch 1 and switch 2 is Current. Switch positions are shown below.

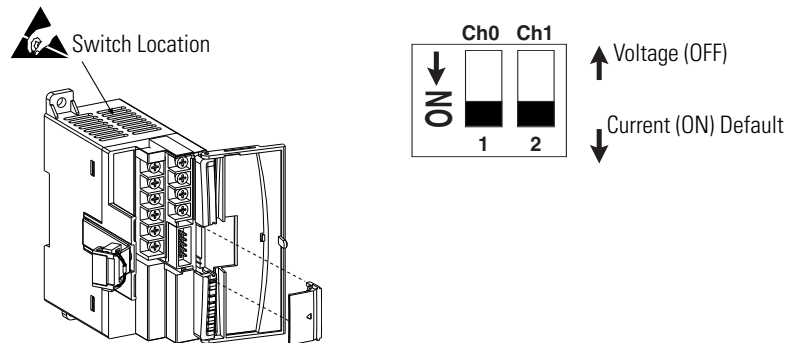

1762-IF2OF2 Output Type Selection

The output type selection, current or voltage, is made by wiring to the appropriate terminals, Iout or Vout, *and* by the type/range selection bits in the Configuration Data File. Refer to MicroLogix 1100 Programmable Controllers Instruction Set Reference Manual, publication 1763-RM001.

ATTENTION



Analog outputs may fluctuate for less than a second when power is applied or removed. This characteristic is common to most analog outputs. While the majority of loads will not recognize this short signal, it is recommended that preventive measures be taken to ensure that connected equipment is not affected.

1762-IF2OF2 Wiring

The following illustration shows the 1762-IF2OF2 analog expansion I/O terminal block.

1762-IF2OF2 Terminal Block Layout

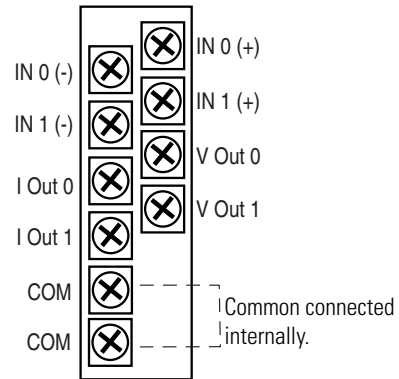

Differential Sensor Transmitter Types

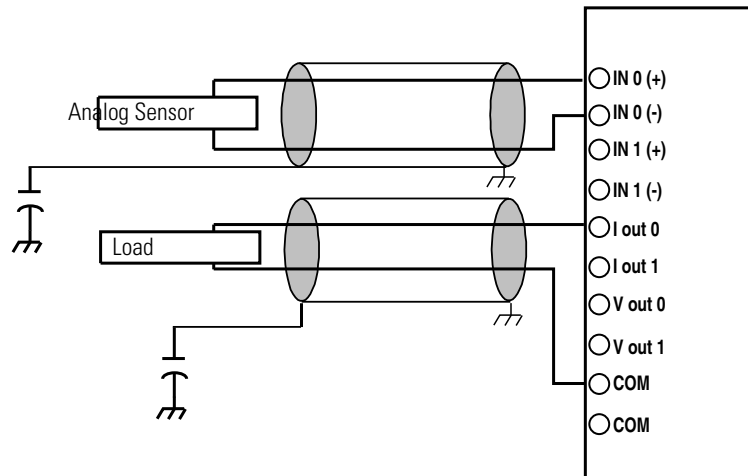

Single-ended Sensor/Transmitter Types

2-Wire Transmitter

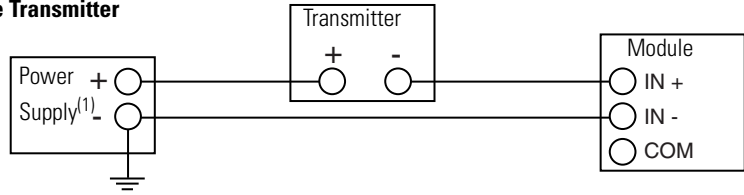

3-Wire Transmitter

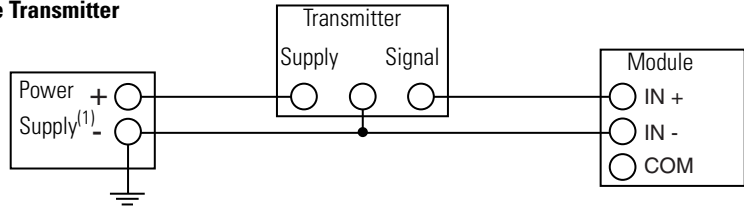

4-Wire Transmitter

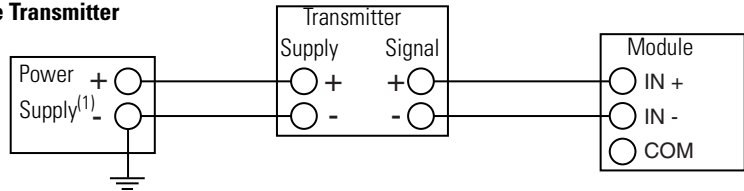

(1) All power supplies rated N.E.C. Class 2.

1762-IF4 Input Type Selection

Select the input type, current or voltage, using the switches located on the module's circuit board *and* the input type/range selection bits in the Configuration Data File. Refer to *MicroLogix 1100 Programmable Controllers Instruction Set Reference Manual*, publication 1763-RM001. You can access the switches through the ventilation slots on the top of the module.

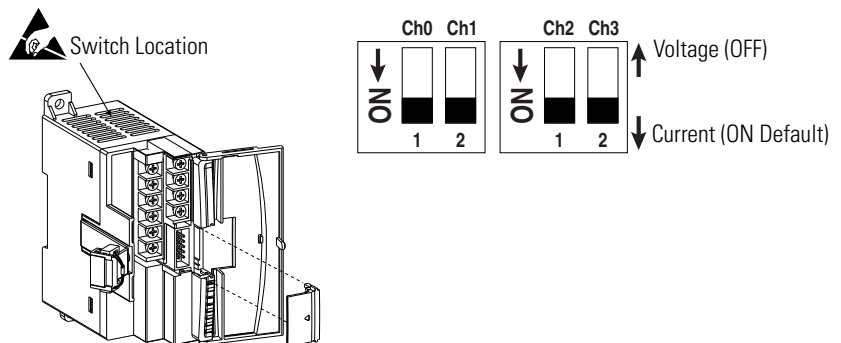

1762-IF4 Terminal Block Layout

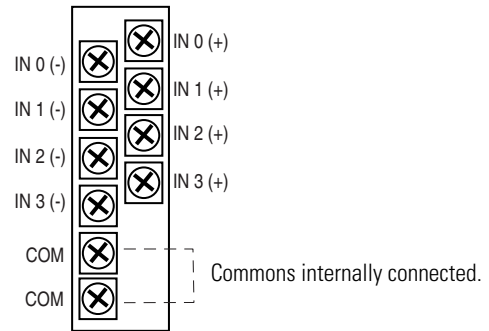

Differential Sensor Transmitter Types

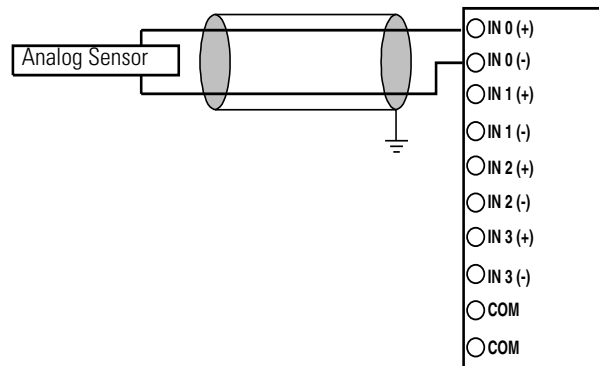

TIP

Grounding the cable shield at the module end only usually provides sufficient noise immunity. However, for best cable shield performance, earth ground the shield at both ends, using a 0.01 μ F capacitor at one end to block AC power ground currents, if necessary.

Sensor/Transmitter Types

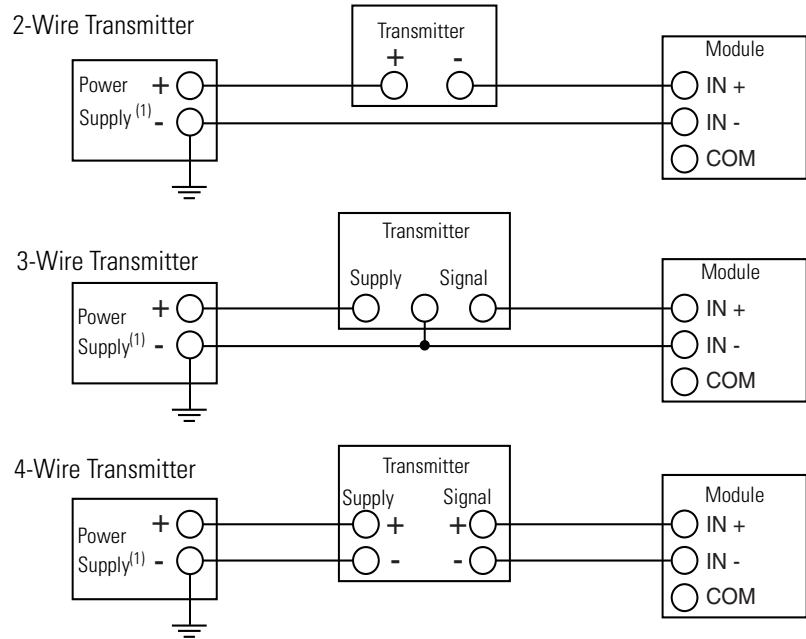

(1) All power supplies rated N.E.C. Class 2.

1762-OF4 Output Type Selection

The output type selection, current or voltage, is made by wiring to the appropriate terminals, I_{out} or V_{out}, and by the type/range selection bits in the Configuration Data File.

1762-OF4 Terminal Block Layout

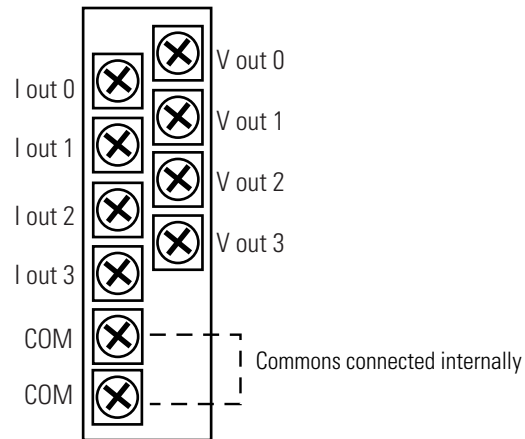

1762-OF4 Wiring

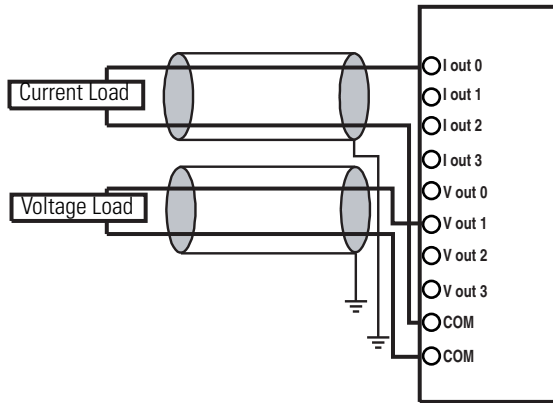

Notes:

Communication Connections

This chapter describes how to communicate with your control system. The method you use and cabling required to connect your controller depends on what type of system you are employing. This chapter also describes how the controller establishes communication with the appropriate network. Topics include:

- supported communication protocols
- default communication configurations
- using communications toggle functionality
- connecting to RS-232 port
- connecting to DH-485 network
- connecting to AIC+
- connecting to Ethernet

The MicroLogix 1100 controllers provide two communication channels, an isolated RS-232/485 communication port (Channel 0) and an Ethernet port (Channel 1).

Supported Communication Protocols

MicroLogix 1100 controllers support the following communication protocols from the primary RS-232/485 communication channel, Channel 0:

- DH-485
- DF1 Full-Duplex
- DF1 Half-Duplex Master and Slave
- DF1 Radio Modem
- Modbus Master and Slave
- ASCII

The Ethernet communication channel, Channel 1, allows your controller to be connected to a local area network for various devices providing 10 Mbps/100 Mbps transfer rate. MicroLogix 1100 controllers support CIP explicit messaging (message exchange). MicroLogix 1100 controllers do not support Ethernet I/O master capability through CIP implicit messaging (real-time I/O messaging).

For more information on MicroLogix 1100 communications, refer to the MicroLogix 1100 Programmable Controllers Instruction Set Reference Manual, publication 1763-RM001.

Default Communication Configuration

The MicroLogix 1100 communication Channel 0 has the following default communication configuration.

TIP

For Channel 0, the default configuration is present when:

- The controller is powered-up for the first time.
- The communications toggle functionality specifies default communications (specified using the LCD Display. The DCOMM indicator on the LCD Display is on, i.e., lit in solid rectangle).
- An OS upgrade is completed.

See [Chapter 5](#) for more information about using the LCD Display.

See [Appendix E](#) for more information about communicating.

DF1 Full-Duplex Default Configuration Parameters

Parameter	Default
Baud Rate	19.2 Kbps
Parity	none
Source ID (Node Address)	1
Control Line	no handshaking
Error Detection	CRC
Embedded Responses	auto detect
Duplicate Packet (Message) Detect	enabled
ACK Timeout	50 counts
NAK retries	3 retries
ENQ retries	3 retries
Stop Bits	1
Data Bits	8

Using the Communications Toggle Functionality

The Communications Toggle Functionality can be operated using the LCD display on the controller, as shown below.

Use the Communications Toggle Functionality to change from the user-defined communication configuration to the default communications mode and back on Channel 0. The Default Communications (DCOMM)

indicator on the LCD display operates to show when the controller is in the default communications mode (settings shown on 72).

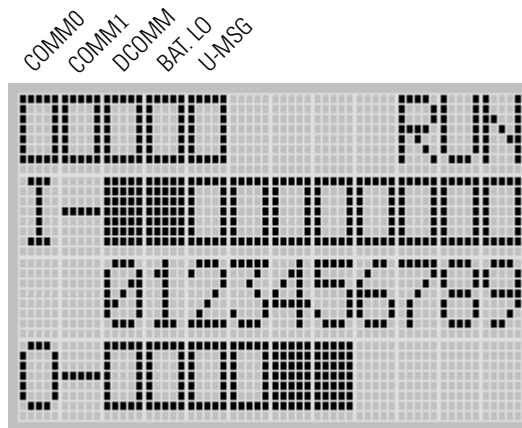

TIP The Communication Toggle Functionality only affects the communication configuration of Channel 0.

Changing Communication Configuration

Follow the procedure below to change from the user-defined communication configuration to the default communications mode and back. In this example, we will start from the Main Menu screen of the LCD display, as shown below. If necessary, press ESC repeatedly until you return to the Main Menu screen.

1. On the Main Menu screen, select Advance Set by using the Up and Down keys on the LCD keypad, as shown below. If the menu items shown in the figure below are not displayed on the Main Menu screen, you need to scroll down the screen by pressing the Down key.



- Then, press the OK key on the LCD keypad. The Advanced Settings Menu screen is displayed, as shown below.

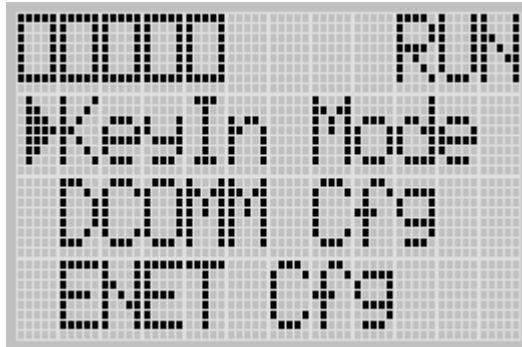

- Select DCOMM Cfg using the Up and Down keys, as shown below, and then press the OK key.

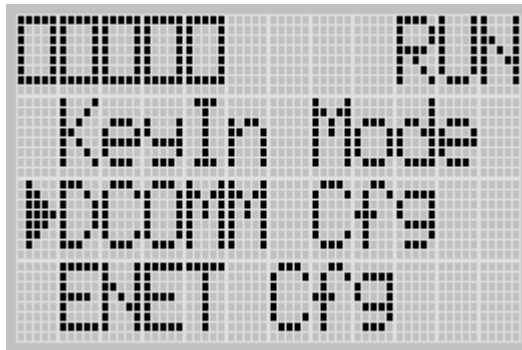

- The DCOMM Configuration screen is displayed, as shown below. The current status, Disable in this example, is selected by default.

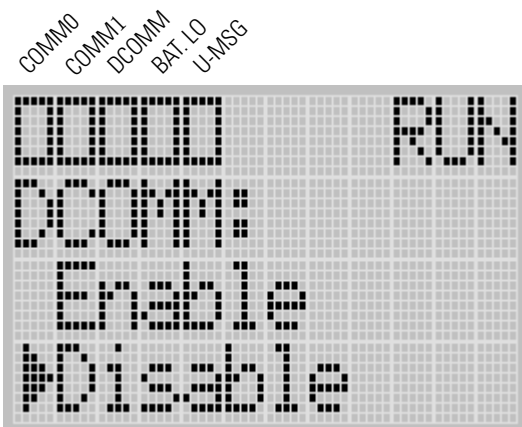

The DCOMM status indicator, which is the third of the five indicators at the top left of the LED display, is displayed in empty rectangle. It means that the communication configuration is set to a user-defined communication mode at present.

If the communication configuration is set to the default communication mode, the DCOMM Configuration screen is displayed as shown below. The DCOMM status indicator is displayed in solid rectangle.

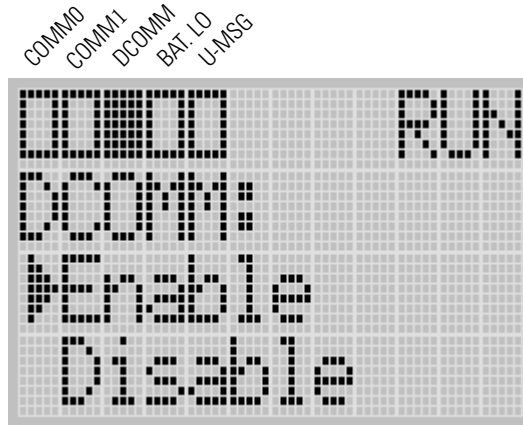

- Use the up arrow to change the indicator position so that it is pointing to Enable. Press the OK key to change to the default communication mode. The DCOMM Mode Change Notification screen is displayed, as shown below. It indicates that the communication configuration is changed to the default communication mode. The DCOMM status indicator is displayed in solid rectangle.

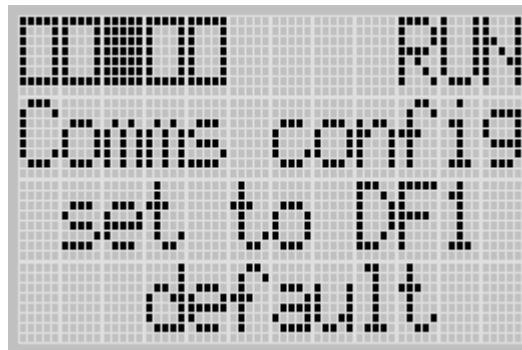

If you change to the user-defined configuration from the default configuration mode by selecting Disable and pressing the OK key, the DCOMM Mode Change Notification will be displayed as shown below.



6. Press the ESC key to return to the Advanced Settings Menu screen, as shown in [step 3](#).

Connecting to the RS-232 Port

There are two ways to connect the MicroLogix™ 1100 programmable controller to your personal computer using the DF1 protocol: using a point-to-point connection, or using a modem. Descriptions of these methods follow.

ATTENTION



All devices connected to the RS-232/485 communication port must be referenced to controller ground, or be floating (not referenced to a potential other than ground). Failure to follow this procedure may result in property damage or personal injury.

- For 1763-L16BWA controllers, the COM of the sensor supply is also connected to chassis ground internally. The 24V DC sensor power source should not be used to power output circuits. It should only be used to power input devices.
- For 1763-L16BBB and 1763-L16DWD controllers, the VDC NEUT or common terminal of the power supply is also connected to chassis ground internally.

Available Communication Cables

Communication Cables	Length
1761-CBL-AM00 Series C or later cables are required for Class I Div 2 applications.	45 cm (17.7 in.)
1761-CBL-AP00 Series C or later cables are required for Class I Div 2 applications.	45 cm (17.7 in.)
1761-CBL-PM02 Series C or later cables are required for Class I Div 2 applications.	2 m (6.5 ft)
1761-CBL-HM02 Series C or later cables are required for Class I Div 2 applications.	2 m (6.5 ft)
1761-CBL-PH02 Series A or later cables are required for Class I Div 2 applications.	2 m (6.5 ft)
1761-CBL-AH02 Series A or later cables are required for Class I Div 2 applications.	2 m (6.5 ft)
2707-NC9 Series C or later cables are required for Class I Div 2 applications.	15 m (49.2 ft)
1763-NC01 Series A or later	30 cm (11.8 in.)

ATTENTION**UNSUPPORTED CONNECTION**

Do not connect a MicroLogix 1100 controller to another MicroLogix family controller such as MicroLogix 1000, MicroLogix 1200, MicroLogix 1500, or to the 1747-DPS1 Network port using a 1761-CBL-AM00 (8-pin mini-DIN to 8-pin mini-DIN) cable or equivalent.

This type of connection will cause damage to the RS-232/485 communication port (Channel 0) of the MicroLogix 1100 and/or the controller itself. Communication pins used for RS-485 communications are alternately used for 24V power on the other MicroLogix controllers and the 1747-DPS1 network port .

Making a DF1 Point-to-Point Connection

You can connect the MicroLogix™ 1100 programmable controller to your personal computer using a serial cable (1761-CBL-PM02) from your personal computer's serial port to the controller's Channel 0. The recommended protocol for this configuration is DF1 Full-Duplex.

You can connect a MicroLogix 1100 controller to your personal computer directly without using an external optical isolator, such as Advanced Interface Converter (AIC+), catalog number 1761-NET-AIC, as shown in the illustration below, because Channel 0 is isolated within the controller.

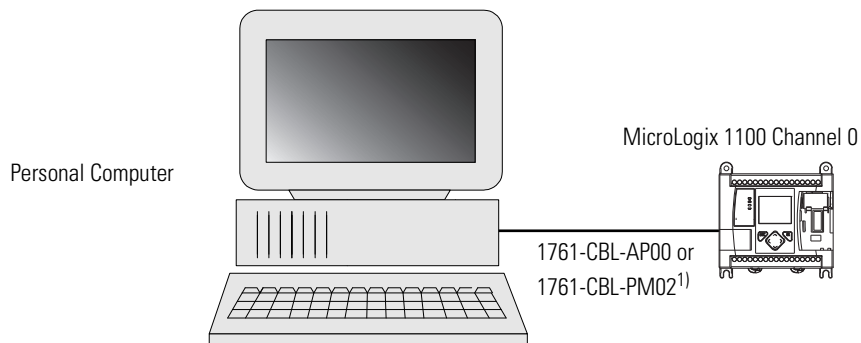

(1) Series C or later cables are required for Class I Div 2 applications.

Using a Modem

You can use modems to connect a personal computer to one MicroLogix™ 1100 controller (using DF1 Full-Duplex protocol), to multiple controllers (using DF1 Half-Duplex protocol), or Modbus RTU Slave protocol via Channel 0, as shown in the following illustration. (See [Appendix E](#) for information on types of modems you can use with the micro controllers.)

IMPORTANT

Do not attempt to use DH-485 protocol through modems under any circumstance. The communication timing using DH-485 protocol is not supported by modem communications.

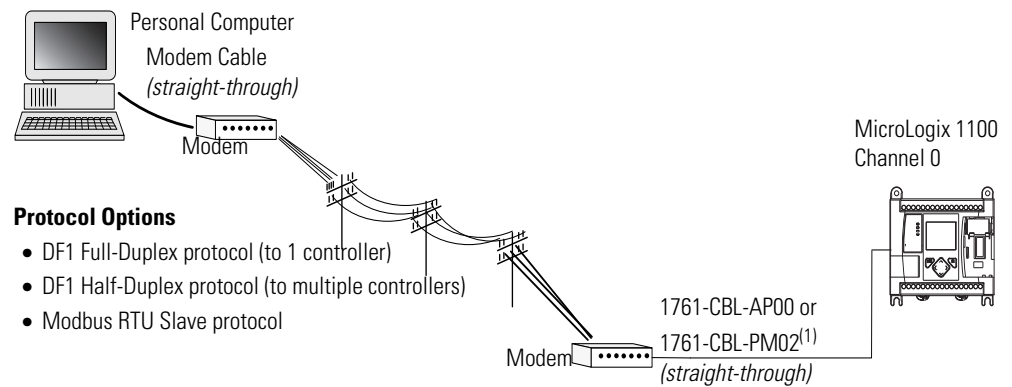

(1) Series C or later cables are required for Class I Div 2 applications.

You can connect a MicroLogix 1100 controller to your modem directly without using an external optical isolator, such as AIC+, catalog number 1761-NET-AIC, as shown in the illustration below, because Channel 0 is isolated within the controller.

MicroLogix 1100 Channel 0 to Modem Cable Pinout

When connecting MicroLogix 1100 Channel 0 to a modem using an RS-232 cable, the maximum that the cable length may be extended is 15.24 m (50 ft).

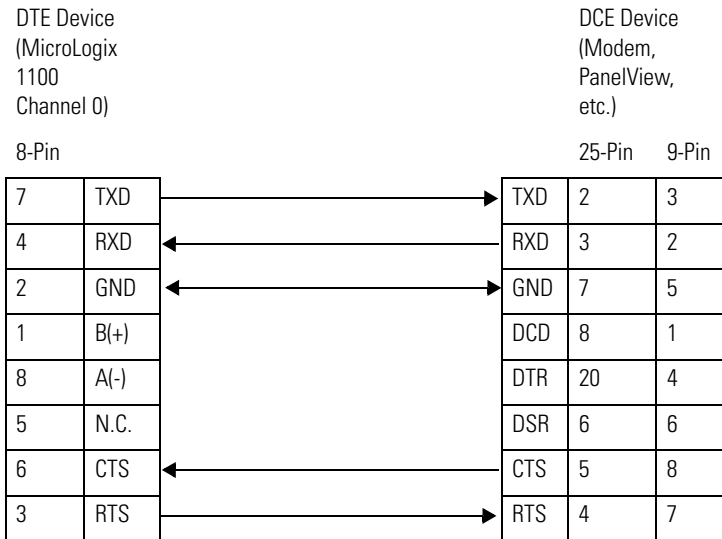

ATTENTION



Do not connect pin 1,8, and 5. This connection will cause damage to the RS-232/485 communication port (channel 0) of the MicroLogix 1100 and/or the controller itself.

Connecting to a DF1 Half-Duplex Network

When a communication port is configured for DF1 Half-Duplex Slave, available parameters include the following:

DF1 Half-Duplex Configuration Parameters

Parameter	Options
Baud Rate	300, 600, 1200, 2400, 4800, 9600, 19.2 Kbps, 38.4 Kbps
Parity	none, even
Node Address	0...254 decimal
Control Line	no handshaking, half duplex modem (RTS/CTS handshaking, no handshaking (485 network))
Error Detection	CRC, BCC
EOT Suppression	enabled, disabled When EOT Suppression is enabled, the slave does not respond when polled if no message is queued. This saves modem transmission power and time when there is no message to transmit.
Duplicate Packet (Message) Detect	enabled, disabled Detects and eliminates duplicate responses to a message. Duplicate packets may be sent under noisy communication conditions if the sender's Message Retries are not set to 0.
Poll Timeout (x20 ms)	0...65,535 (can be set in 20 ms increments) Poll Timeout only applies when a slave device initiates a MSG instruction. It is the amount of time that the slave device waits for a poll from the master device. If the slave device does not receive a poll within the Poll Timeout, a MSG instruction error is generated, and the ladder program needs to requeue the MSG instruction. If you are using a MSG instruction, it is recommended that a Poll Timeout value of zero not be used. Poll Timeout is disabled when set to zero.
RTS Off Delay (x20 ms)	0...65,535 (can be set in 20 ms increments) Specifies the delay time between when the last serial character is sent to the modem and when RTS is deactivated. Gives the modem extra time to transmit the last character of a packet.
RTS Send Delay (x20 ms)	0...65,535 (can be set in 20 ms increments) Specifies the time delay between setting RTS until checking for the CTS response. For use with modems that are not ready to respond with CTS immediately upon receipt of RTS.
Message Retries	0...255 Specifies the number of times a slave device attempts to resend a message packet when it does not receive an ACK from the master device. For use in noisy environments where message packets may become corrupted in transmission.
Pre Transmit Delay (x1 ms)	0...65,535 (can be set in 1 ms increments) <ul style="list-style-type: none"> When the Control Line is set to <i>no handshaking</i>, this is the delay time before transmission. Required for 1761-NET-AIC physical Half-Duplex networks. The 1761-NET-AIC needs delay time to change from transmit to receive mode. When the Control Line is set to <i>DF1 Half-Duplex Modem</i>, this is the minimum time delay between receiving the last character of a packet and the RTS assertion.

DF1 Half-Duplex Master-Slave Network

Use the following diagram for DF1 Half-Duplex Master-Slave protocol without hardware handshaking.

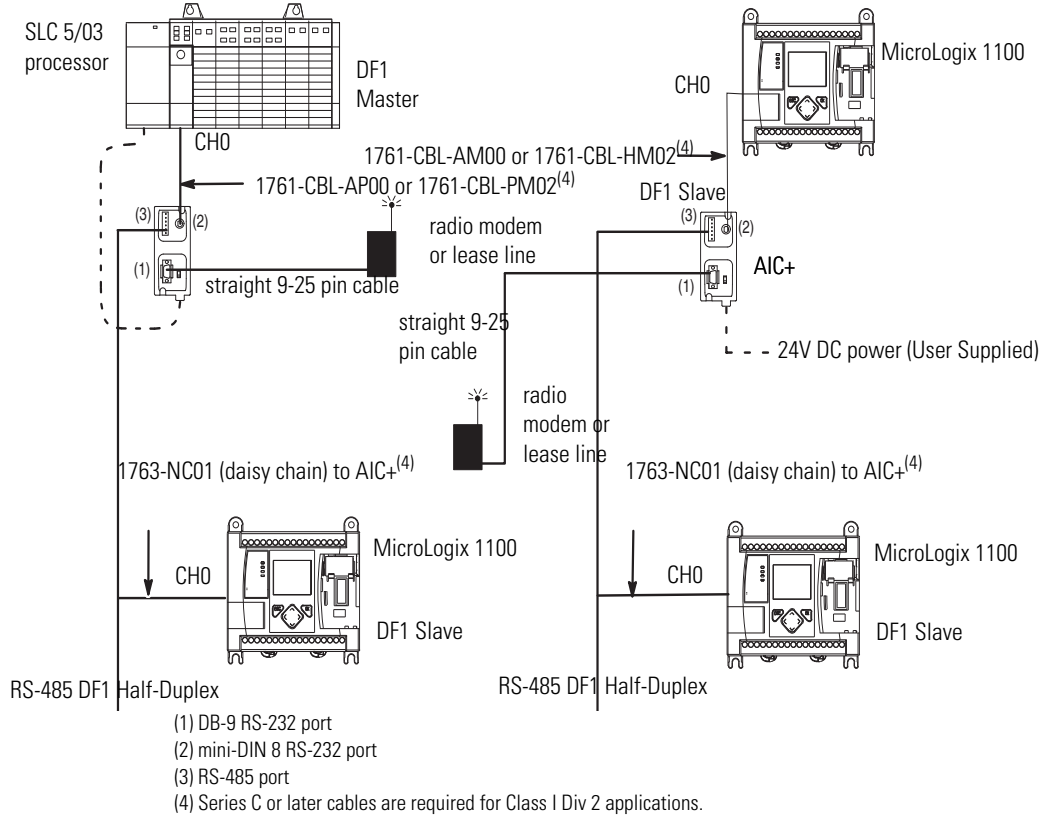

DF1 Half-Duplex Network (Using PC and Modems)

Rockwell Software RSLinx 2.0 (or higher), SLC 5/03, SLC 5/04, SLC 5/05, PLC-5, or MicroLogix 1000, 1200, and 1500 processors configured for DF1 Half-Duplex Master. Rockwell Software RSLinx 2.5 required for MicroLogix 1100.

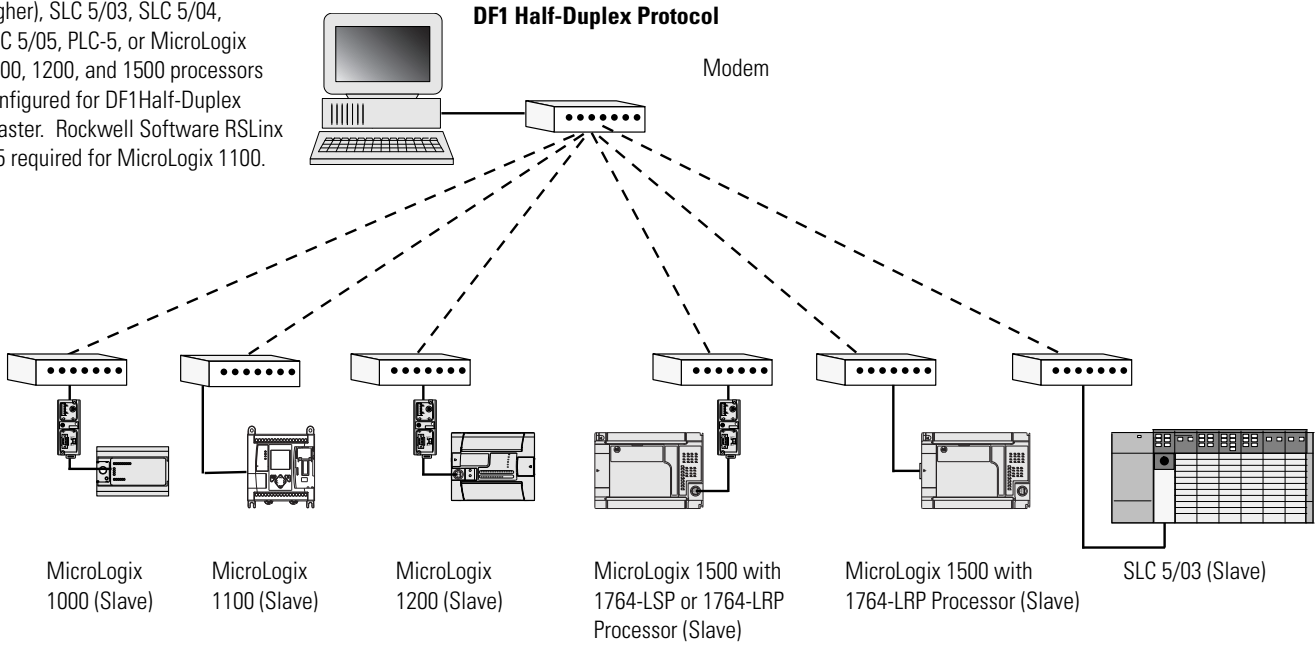

Connecting to a DH-485 Network

The network diagrams on the next pages provide examples of how to connect MicroLogix 1100 controllers to the DH-485 network.

You can connect a MicroLogix 1100 controller to your DH-485 network directly without using an external optical isolator, such as Advanced Interface Converter (AIC+), catalog number 1761-NET-AIC, as shown in the illustrations below, because Channel 0 is isolated within the controller.

TIP

Use a 1763-NC01 Series A or later (8-pin mini-DIN to 6-pin DH-485 connector) cable or equivalent to connect a MicroLogix 1100 controller to a DH-485 network.

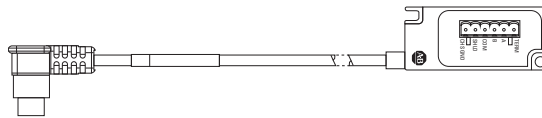

We recommend that you use a 1747-UIC USB interface to connect your PC to a DH-485 network. For more information on the 1747-UIC, see the *Universal Serial Bus to DH-485 Interface Converter Installation Instructions*, publication 1747-IN063.

DH-485 Configuration Parameters

When MicroLogix communications are configured for DH-485, the following parameters can be changed:

DF1 Full-Duplex Configuration Parameters

Parameter	Options
Baud Rate	9600, 19.2 KBps
Node Address	1...31 decimal
Token Hold Factor	1...4

See [Software Considerations on page 212](#) for tips on setting the parameters listed above.

DH-485 Network with a MicroLogix 1100 Controller

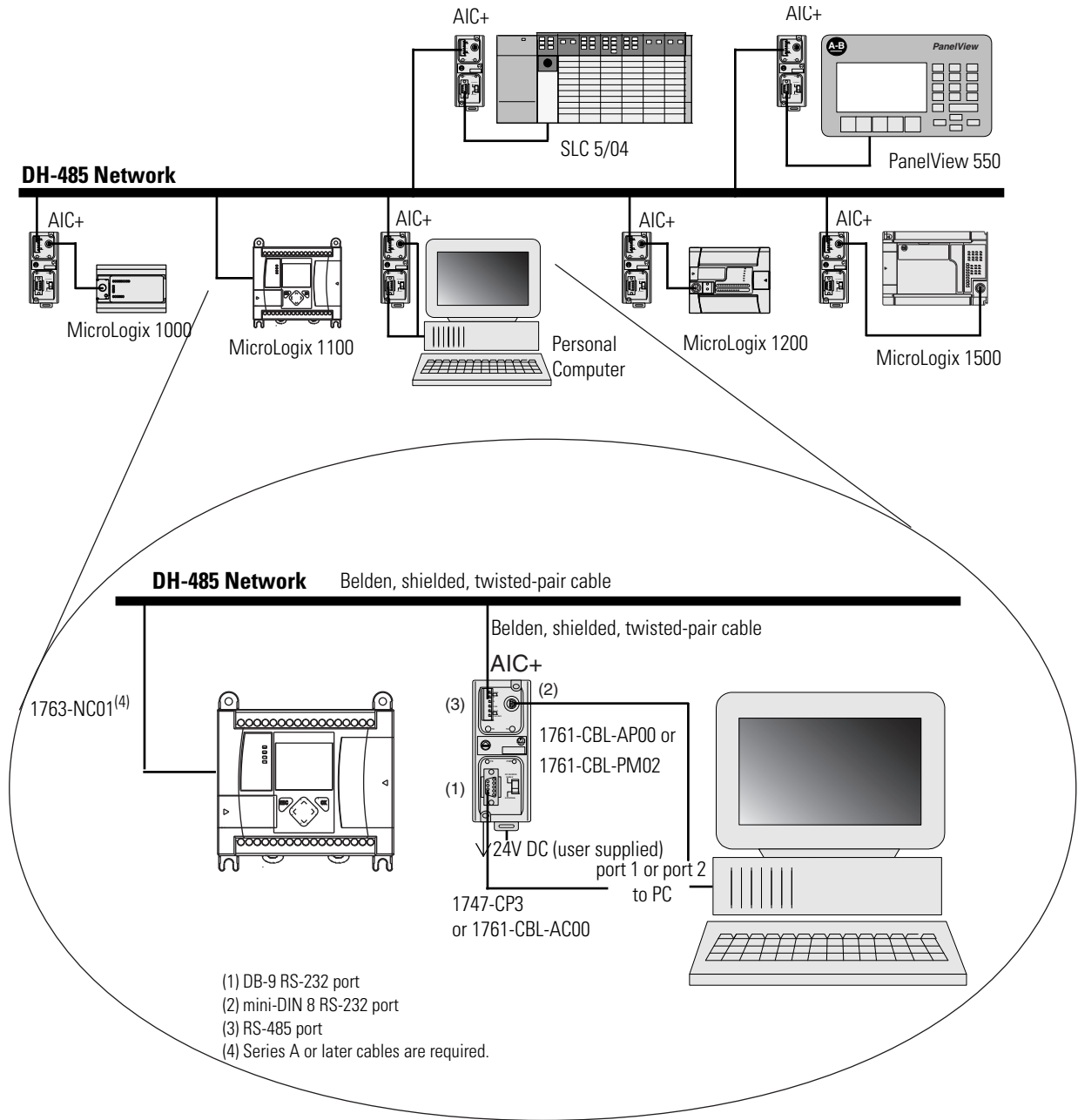

Typical 3-Node Network (Channel 0 Connection)

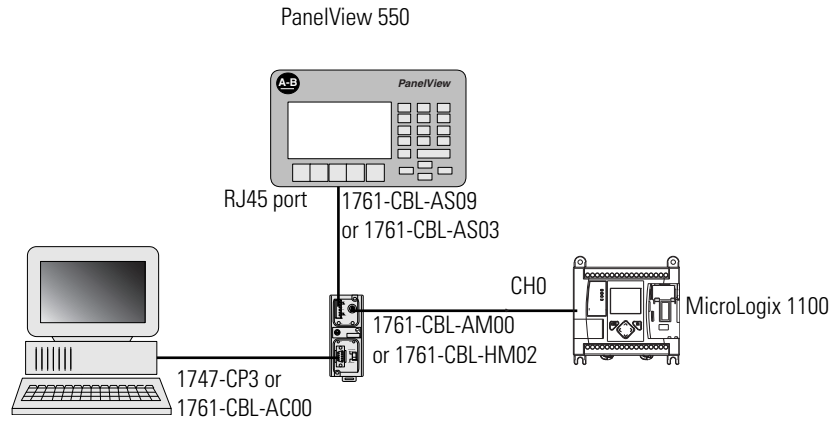

Recommended Tools

To connect a DH-485 network to additional devices, you need tools to strip the shielded cable and to attach the cable to the AIC+ Advanced Interface Converter. We recommend the following equipment (or equivalent):

Working with Cable for DH-485 Network

Description	Part Number	Manufacturer
Shielded Twisted Pair Cable	#3106A or #9842	Belden
Stripping Tool	Not Applicable	Not Applicable
1/8" Slotted Screwdriver	Not Applicable	Not Applicable

DH-485 Communication Cable

The suggested DH-485 communication cable is either Belden #3106A or #9842. The cable is jacketed and shielded with one or two twisted-wire pairs and a drain wire.

One pair provides a balanced signal line and one additional wire is used for a common reference line between all nodes on the network. The shield reduces the effect of electrostatic noise from the industrial environment on network communication.

The communication cable consists of a number of cable segments daisy-chained together. The total length of the cable segments cannot exceed 1219 m (4000 ft). However, two segments can be used to extend the DH-485

network to 2438 m (8000 ft). For additional information on connections using the AIC+, refer to the Advanced Interface Converter (AIC+) User Manual, publication 1761-6.4.

When cutting cable segments, make them long enough to route them from one AIC+ to the next, with sufficient slack to prevent strain on the connector. Allow enough extra cable to prevent chafing and kinking in the cable.

Use these instructions for wiring the Belden #3106A or #9842 cable. (See [Cable Selection Guide on page 90](#) if you are using standard Allen-Bradley cables.)

Connecting the Communication Cable to the DH-485 Connector

TIP A daisy-chained network is recommended. Do *not* make the incorrect connection shown below:

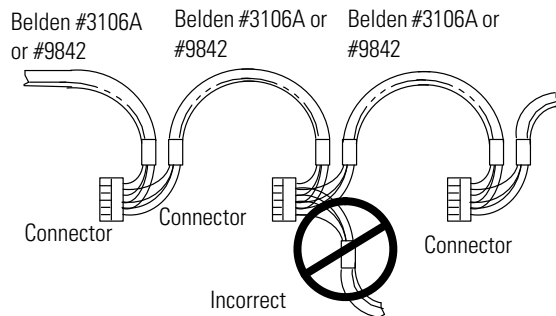

Single Cable Connection

When connecting a single cable to the DH-485 connector, use the following diagram.

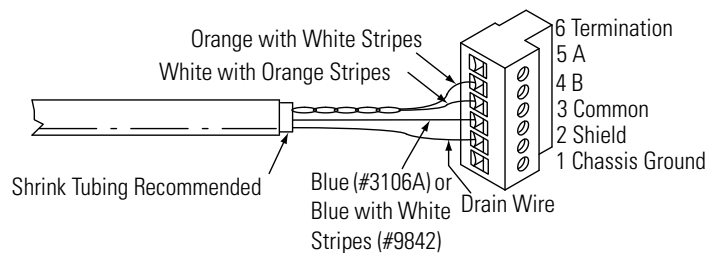

Multiple Cable Connection

When connecting multiple cables to the DH-485 connector, use the following diagram.

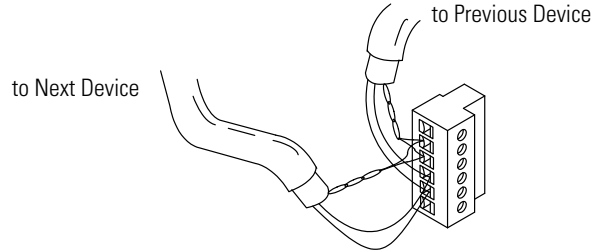

Connections using Belden #3106A Cable

For this Wire/Pair	Connect this Wire	To this Terminal
Shield/Drain	Non-jacketed	Terminal 2 - Shield
Blue	Blue	Terminal 3 - (Common)
White/Orange	White with Orange Stripe	Terminal 4 - (Data B)
	Orange with White Stripe	Terminal 5 - (Data A)

Connections using Belden #9842 Cable

For this Wire/Pair	Connect this Wire	To this Terminal
Shield/Drain	Non-jacketed	Terminal 2 - Shield
Blue/White	White with Blue Stripe	Cut back - no connection ⁽¹⁾
	Blue with White Stripe	Terminal 3 - (Common)
White/Orange	White with Orange Stripe	Terminal 4 - (Data B)
	Orange with White Stripe	Terminal 5 - (Data A)

⁽¹⁾ To prevent confusion when installing the communication cable, cut back the white with blue stripe wire immediately after the insulation jacket is removed. This wire is not used by DH-485.

Grounding and Terminating the DH-485 Network

Only one connector at the end of the link must have Terminals 1 and 2 jumpered together. This provides an earth ground connection for the shield of the communication cable.

Both ends of the network must have Terminals 5 and 6 jumpered together, as shown below. This connects the termination impedance (of 120 ohm) that is built into each AIC+ or the 1763-NC01 cable as required by the DH-485 specification.

End-of-Line Termination

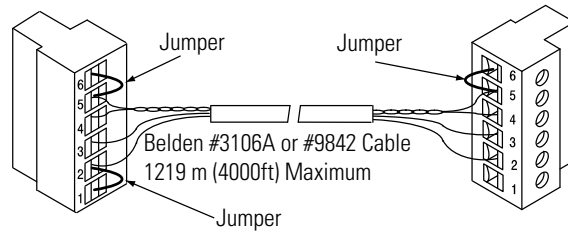

MicroLogix 1100 Channel 0 to DH-485 Communication Cable Pinout

When connecting MicroLogix 1100 Channel 0 to DH-485 communication cable pinout using an RS-232 cable, the maximum that the cable length may be extended is 15.24 m (50 ft). Refer to the following typical pinout:

DTE Device
(MicroLogix
1100
Channel 0)

DCE Device (DH-485
connector)

8-Pin

6-pin

7	TXD
4	RXD
2	GND
1	B(+)
8	A(-)
5	N.C.
6	CTS
3	RTS

6	Termination
5	A
4	B
3	Common
2	Shield
1	ChassisGround

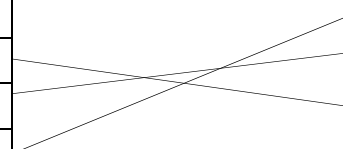

Connecting the AIC+

You can connect a MicroLogix 1100 controller to a DH-485 network via Channel 0 directly without using an optical isolator, such as AIC+, catalog number 1761-NET-AIC, because Channel 0 is isolated. However, you need to use an AIC+ to connect your PC or other MicroLogix Family products, such as MicroLogix 1200, to a DH-485 network.

The following figure shows the external wiring connections and specifications of the AIC+.

**AIC+ Advanced Interface Converter
(1761-NET-AIC)**

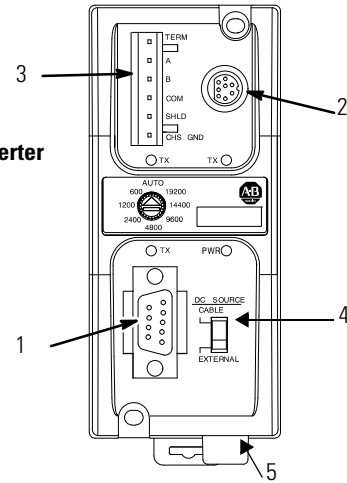

Item	Description
1	Port 1 - DB-9 RS-232, DTE
2	Port 2 - mini-DIN 8 RS-232 DTE
3	Port 3 - RS-485 Phoenix plug
4	DC Power Source selector switch (cable = port 2 power source, external = external power source connected to item 5)
5	Terminals for external 24V DC power supply and chassis ground

For additional information on connecting the AIC+, refer to the Advanced Interface Converter (AIC+) User Manual, publication 1761-UM00.

Cable Selection Guide

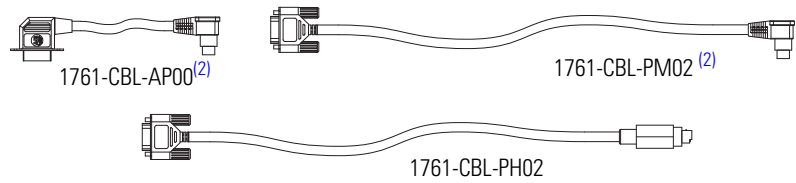

Cable	Length	Connections from	to AIC+	External Power Supply Required ⁽¹⁾	Power Selection Switch Setting ⁽¹⁾
1761-CBL-AP00 ⁽²⁾ 1761-CBL-PM02 ⁽²⁾ 1761-CBL-PH02	45 cm (17.7 in.) 2 m (6.5 ft) 2 m (6.5 ft)	SLC 5/03 or SLC 5/04 processors, ch 0	port 2	yes	external
		MicroLogix™ 1000, 1200, or 1500 ch 0	port 1	yes	external
		MicroLogix™ 1100 ch 0	port 1	yes	external
		PanelView™ 550 through NULL modem adapter	port 2	yes	external
		DTAM Plus / DTAM Micro	port 2	yes	external
		PC COM port	port 2	yes	external

⁽¹⁾ External power supply required unless the AIC+ is powered by the device connected to port 2, then the selection switch should be set to *cable* .

⁽²⁾ Series C or later cables are required.

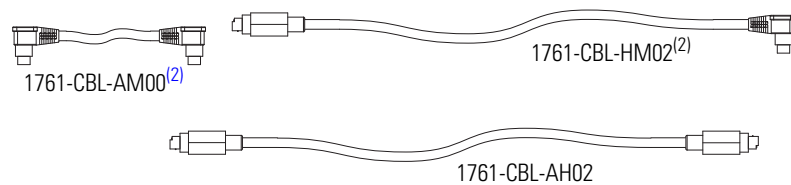

Cable	Length	Connections from	to AIC+	External Power Supply Required ⁽¹⁾	Power Selection Switch Setting
1761-CBL-AM00 ⁽²⁾ 1761-CBL-HM02 ⁽²⁾ 1761-CBL-AH02	45 cm (17.7 in.) 2 m (6.5 ft) 2 m (6.5 ft)	MicroLogix™ 1000, 1200, or 1500 ch 0	port 2	no	cable
		MicroLogix™ 1100 ch 0	port 2	Yes	external
		to port 2 on another AIC+	port 2	yes	external

⁽¹⁾ External power supply required unless the AIC+ is powered by the device connected to port 2, then the selection switch should be set to *cable* .

⁽²⁾ Series C or later cables are required.



Cable	Length	Connections from	to AIC+	External Power Supply Required ⁽¹⁾	Power Selection Switch Setting ⁽¹⁾
1747-CP3	3 m (9.8 ft)	SLC 5/03 or SLC 5/04 processor, channel 0	port 1	yes	external
1761-CBL-AC00 ⁽¹⁾	45 cm (17.7 in.)	PC COM port	port 1	yes	external
		PanelView 550 through NULL modem adapter	port 1	yes	external
		DTAM Plus / DTAM Micro™	port 1	yes	external
		Port 1 on another AIC+	port 1	yes	external

⁽¹⁾ External power supply required unless the AIC+ is powered by the device connected to port 2, then the selection switch should be set to *cabl*e.



Cable	Length	Connections from	to AIC+	External Power Supply Required ⁽¹⁾	Power Selection Switch Setting ⁽¹⁾
straight 9-25 pin	—	modem or other communication device	port 1	yes	external

⁽¹⁾ External power supply required unless the AIC+ is powered by the device connected to port 2, then the selection switch should be set to *cabl*e.

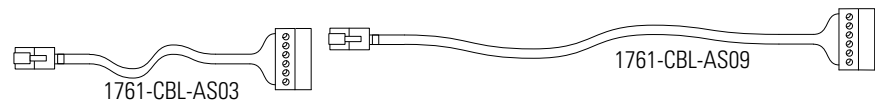

Cable	Length	Connections from	to AIC+	External Power Supply Required ⁽¹⁾	Power Selection Switch Setting ⁽¹⁾
1761-CBL-AS03	3 m (9.8 ft)	SLC 500 Fixed,	port 3	yes	external
1761-CBL-AS09	9.5 m (31.17 ft)	SLC 5/01, SLC 5/02, and SLC 5/03 processors			
		PanelView 550 RJ45 port	port 3	yes	external

⁽¹⁾ External power supply required unless the AIC+ is powered by the device connected to port 2, then the selection switch should be set to *cabl*e.

1761-CBL-PM02 Series C (or equivalent) Cable Wiring Diagram

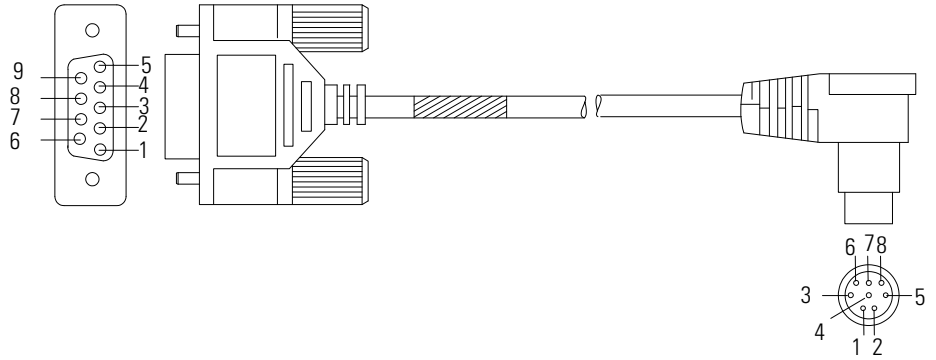

Programming Device

9-Pin D-Shell

9	RI
8	CTS
7	RTS
6	DSR
5	GND
4	DTR
3	TXD
2	RXD
1	DCD

Controller

8-Pin Mini Din

24V	1
GND	2
RTS	3
RXD	4
DCD	5
CTS	6
TXD	7
GND	8

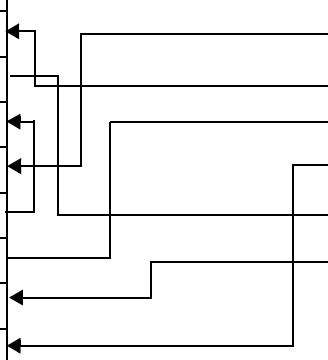

Recommended User-Supplied Components

These components can be purchased from your local electronics supplier.

User Supplied Components

Component	Recommended Model
external power supply and chassis ground	power supply rated for 20.4...28.8V DC
NULL modem adapter	standard AT
straight 9-25 pin RS-232 cable	see table below for port information if making own cables

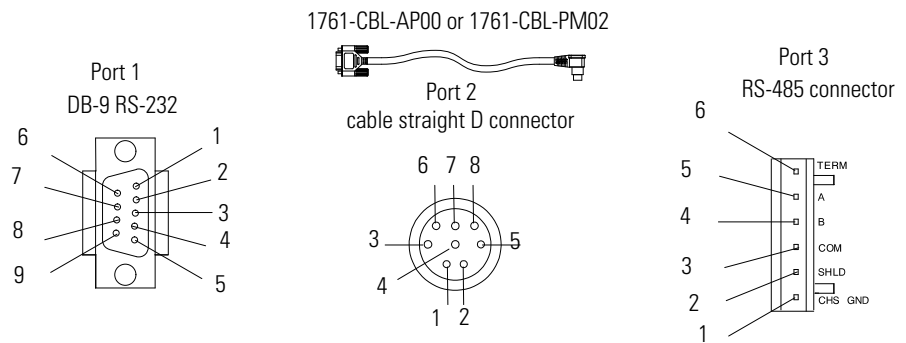

AIC+ Terminals

Pin	Port 1: DB-9 RS-232	Port 2 ⁽²⁾ : (1761-CBL-PM02 cable)	Port 3: RS-485 Connector
1	received line signal detector (DCD)	24V DC	chassis ground
2	received data (RxD)	ground (GND)	cable shield
3	transmitted data (TxD)	request to send (RTS)	signal ground
4	DTE ready (DTR) ⁽¹⁾	received data (RxD) ⁽³⁾	DH-485 data B
5	signal common (GND)	received line signal detector (DCD)	DH-485 data A
6	DCE ready (DSR) ⁽¹⁾	clear to send (CTS) ⁽³⁾	termination
7	request to send (RTS)	transmitted data (TxD)	not applicable
8	clear to send (CTS)	ground (GND)	not applicable
9	not applicable	not applicable	not applicable

⁽¹⁾ On port 1, pin 4 is electronically jumpered to pin 6. Whenever the AIC+ is powered on, pin 4 will match the state of pin 6.

⁽²⁾ An 8-pin mini DIN connector is used for making connections to port 2. This connector is not commercially available. If you are making a cable to connect to port 2, you must configure your cable to connect to the Allen-Bradley cable shown above.

⁽³⁾ In the 1761-CBL-PM02 cable, pins 4 and 6 are jumpered together within the DB-9 connector.

Safety Considerations

This equipment is suitable for use in Class I, Division 2, Groups A, B, C, D or non-hazardous locations only.

WARNING**EXPLOSION HAZARD**

AIC+ must be operated from an external power source.

This product must be installed in an enclosure. All cables connected to the product must remain in the enclosure or be protected by conduit or other means.

[See Safety Considerations on page 21](#) for additional information.

Install and Attach the AIC+

1. Take care when installing the AIC+ in an enclosure so that the cable connecting the MicroLogix™ controller to the AIC+ does not interfere with the enclosure door.
2. Carefully plug the terminal block into the RS-485 port on the AIC+ you are putting on the network. Allow enough cable slack to prevent stress on the plug.
3. Provide strain relief for the Belden cable after it is wired to the terminal block. This guards against breakage of the Belden cable wires.

Powering the AIC+

MicroLogix 100, 1200, and 1500 programmable controllers support 24V DC communication power on Channel 0. When connected to the 8 pin mini-DIN connector on the 1761-NET-AIC, 1761-NET-ENI, and the 1761-NET-ENIW, these controllers provide the power for the interface converter modules. The MicroLogix 1100 does not provide 24V DC communication power. Instead these pins are used to provide RS-485 communications directly. Any AIC+, ENI, or ENIW not connected to a MicroLogix 1000, 1200, or 1500 controller requires a 24V DC power supply.

If both the controller and external power are connected to the AIC+, the power selection switch determines what device powers the AIC+.

ATTENTION



If you use an external power supply, it must be 24V DC (-15%/+20%). Permanent damage results if a higher voltage supply is used.

Set the DC Power Source selector switch to EXTERNAL before connecting the power supply to the AIC+. The following illustration shows where to connect external power for the AIC+.

Bottom View

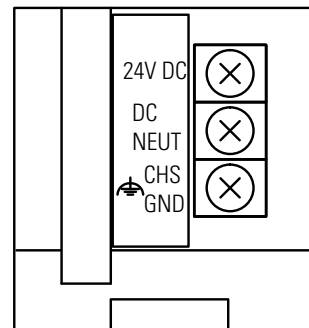

ATTENTION



Always connect the CHS GND (chassis ground) terminal to the nearest earth ground. This connection must be made whether or not an external 24V DC supply is used.

Power Options

Below are two options for powering the AIC+:

- Use the 24V DC user power supply built into the MicroLogix™ 1000, 1200, or 1500 controller. The AIC+ is powered through a hard-wired connection using a communication cable (1761-CBL-HM02, or equivalent) connected to port 2.
- Use an external DC power supply with the following specifications:
 - operating voltage: 24V DC (-15%/+20%)
 - output current: 150 mA minimum
 - rated NEC Class 2

Make a hard-wired connection from the external supply to the screw terminals on the bottom of the AIC+.

ATTENTION

If you use an external power supply, it must be 24V DC (-15%/+20%). Permanent damage results if miswired with the wrong power source.

Connecting to Ethernet

You can connect directly a MicroLogix™ 1100 to an Ethernet network via the Ethernet port (Channel 1). You do not need to use an Ethernet interface card, such as the Ethernet Interface (ENI) and (ENIW), catalog number 1761-NET-ENI and 1761-NET-ENIW, to connect your MicroLogix 1100 controller to an Ethernet network. For additional information on connecting to an Ethernet network, see [Appendix F](#).

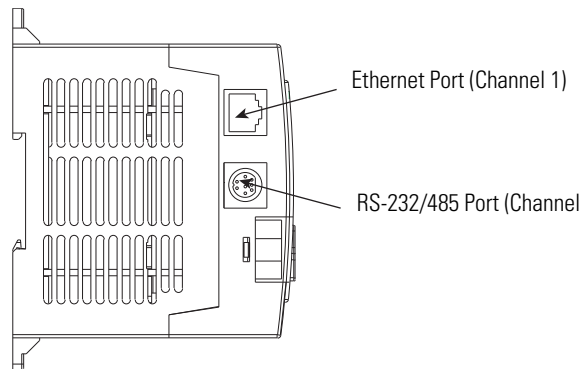

Ethernet Connections

The Ethernet connector, Channel 1, is an RJ45, 10/100Base-T connector. The pin-out for the connector is shown below.

Pin	Pin Name
1	Tx+
2	Tx-
3	Rx+
4	not used by 10/100Base-T
5	not used by 10/100Base-T
6	Rx-
7	not used by 10/100Base-T
8	not used by 10/100Base-T

End view of RJ 45 Plug

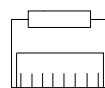

1 2 3 4 5 6 7 8

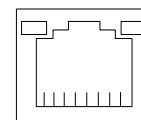

Looking into a RJ45 Jack

8 7 6 5 4 3 2 1

When to use straight-through and cross-over cable:

- MicroLogix 1100 Ethernet port to 10/100Base-T Ethernet switch cables utilize a straight-through pin-out (1-1, 2-2, 3-3, 6-6).
- Direct point-to-point 10/100 Base-T cables connecting the MicroLogix 1100 Ethernet port directly to another Ethernet port (or a computer 10/100Base-T port) require a cross-over pin-out (1-3, 2-6, 3-1, 6-2).

Using the LCD

This chapter describes how to use the LCD and keypad on the MicroLogix 1100 controller. Topics include:

- operating principles
- I/O status display
- monitoring bit file
- monitoring integer file
- using the mode switch
- using a user defined LCD screen
- changing key in mode
- using communications toggle functionality
- viewing Ethernet port configuration
- using trim pots
- viewing system information
- viewing fault code

The LCD and keypad are shown below.

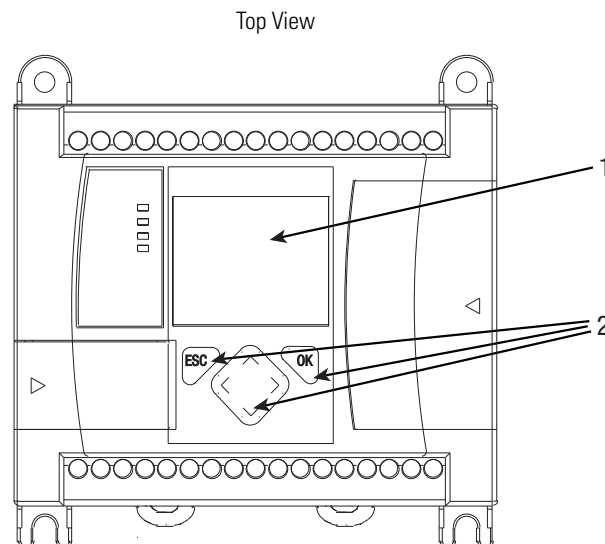

LCD and Keypad

Feature	Description
1	LCD
2	LCD Screen Keypad (ESC, OK, Up, Down, Left, and Right Buttons)

Operating Principles

MicroLogix 1100 LCD Menu Structure Tree

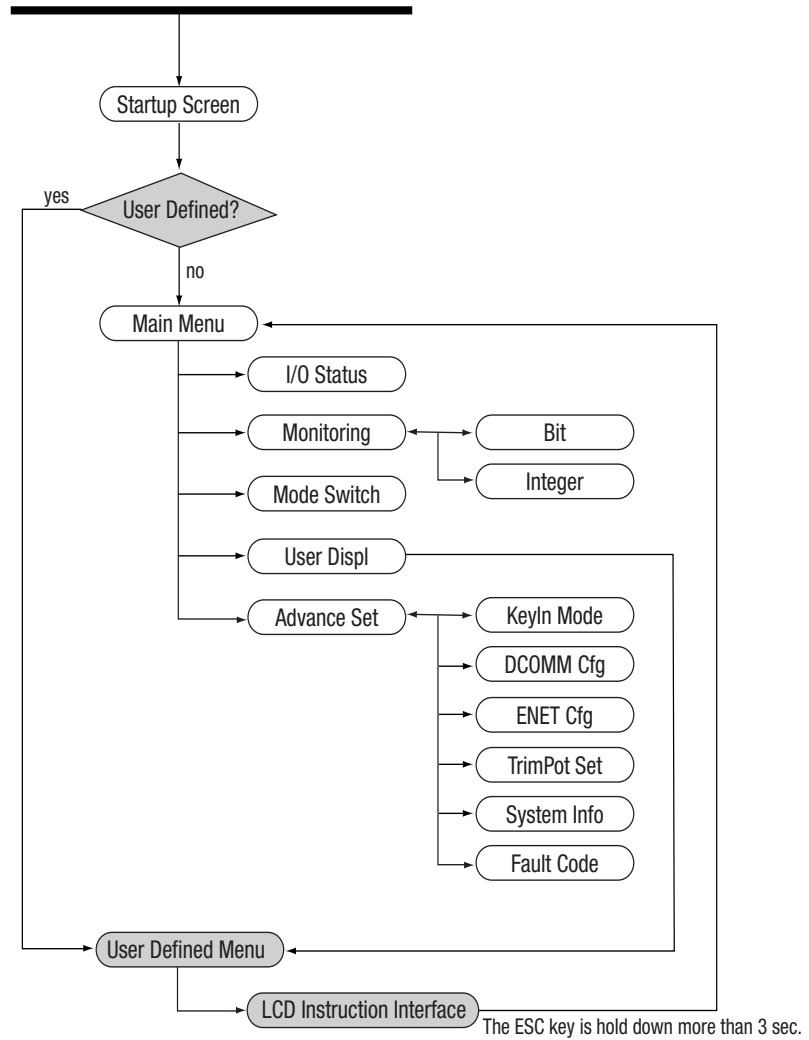

Startup Screen

The Startup screen is displayed whenever the controller is powered up.

LCD Default Startup Screen

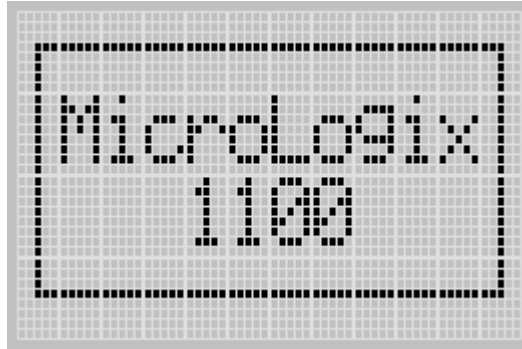

You can customize this Startup screen in your application program by defining a string data file that contains the string to display on the Startup screen and specifying the CBS element of the LCD Function File to the address of this string file.

The screen shown below is an example of a customized Startup screen.

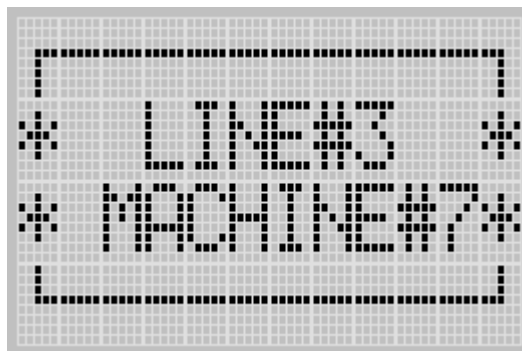

For more information on how to create and use a customized Startup screen, refer to the LCD Function File described in the MicroLogix 1100 Programmable Controllers Instruction Set Reference Manual, publication 1763-RM001.

After the default Startup screen or your customized Startup screen is displayed for 3 seconds, either the default screen (the I/O Status screen) is displayed by default, or a user defined screen is displayed if your application uses a custom default screen.

Main Menu and Default Screen

The Main menu consists of five menu items: I/O Status, Monitoring, Mode Switch, User Displ, and Advance Set.

LCD Main Menu

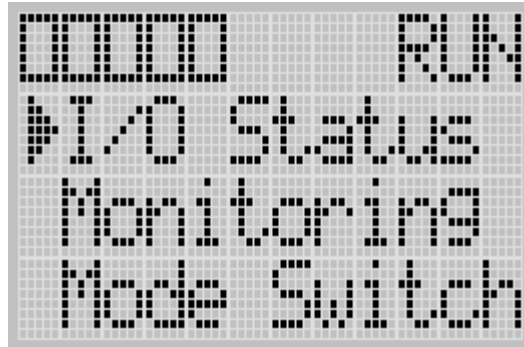

Main Menu Items

Menu Item	Description	For details, refer to
I/O Status	Displays the I/O Status screen, which shows the I/O status of the embedded digital I/O.	I/O Status on page 5-107
Monitoring	Allows you to view and change the data value of a bit and an integer file.	Monitoring Bit File on page 5-109 Monitoring Integer File on page 5-115
Mode Switch	Allows you to change the mode switch selection.	Using the Mode Switch on page 5-122
User Displ	Displays the user defined LCD screen	Using a User Defined LCD Screen on page 5-126
Advance Set	Allows you to configure or view the following: <ul style="list-style-type: none"> • Change the key in mode for value entry for a trim pot. • Use the communications toggle functionality. • View the Ethernet port configuration. • Change the data value of trim pots. • View system information, such as OS series and firmware version. 	<ul style="list-style-type: none"> • Changing Key In Mode on page 5-128 • Using Communications Toggle Functionality on page 5-131 • Viewing Ethernet Port Configuration on page 5-131 • Using Trim Pots on page 5-133 • I/O Status on page 5-107

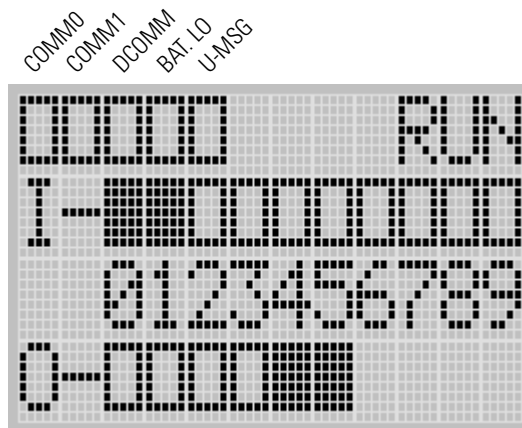
LCD Default Screen - I/O Status Screen

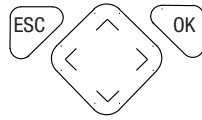

This is the default screen of the display, allowing you to monitor controller and I/O Status. For more information on the I/O Status screen, [see I/O Status on page 5-107](#).

Operating Buttons



Button	Function
Cursor Buttons	Move cursor
	Select menu item
	Choose file numbers, values, etc.
OK	Next menu level, store your entry, apply the changes
ESC	Previous menu level, cancel your entry

Using Menus to Choose Values

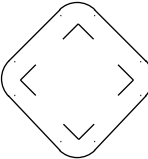
Press	To
	<ul style="list-style-type: none"> • Go to next menu level. • Store your entry. • Apply the changes.
	<ul style="list-style-type: none"> • Go to previous menu level. • Cancel your entry since the last <i>Ok</i>. • Press repeatedly to go to the main menu.
	<ul style="list-style-type: none"> • Change menu item. • Change value. • Change position.

Selecting Between Menu Items

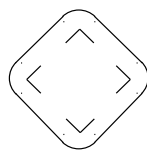

Cursor up or down



Apply or Enter



The symbol "█" is used as the cursor.

Cursor Display

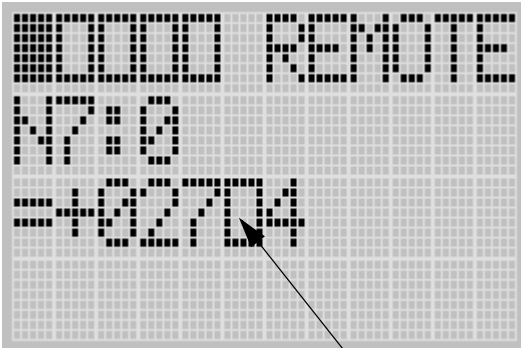
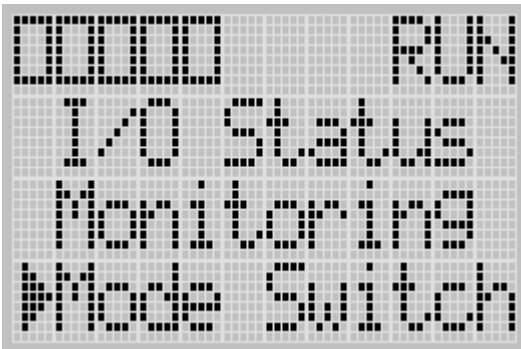

Flashing value is presented as an empty rectangle for explanation purpose.

There are two different cursor types:

Selection cursor (the symbol "█") is displayed left to the selected item.

- Move cursor with the up/down arrows

Full block navigation is shown as a flashing block:

- Change position with left/right arrows
- Change values with up/down arrows

Setting Values

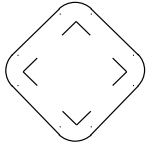

Change value = up/down arrows

Move cursor between digits = left/right arrows



Stores Entries



Retain previous value

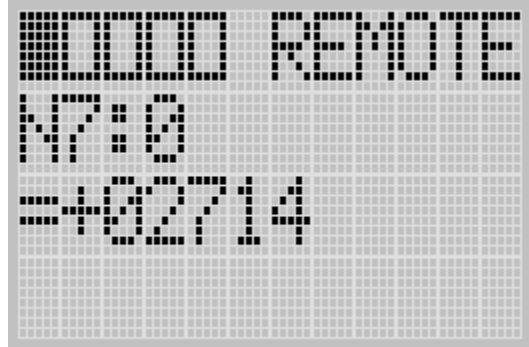

Left/right arrow moves the cursor between the digits of the value (+02714).

Up/down arrow changes the value.

Up arrow = increment

Down arrow = decrement

I/O Status

The MicroLogix 1100 provides I/O status indicators on the LCD screen. You can view the status of inputs and outputs on the I/O Status screen on the LCD, as shown below. The I/O status indicators on this screen are updated every 100 ms to reflect the current I/O status in real time, regardless of controller scan time.

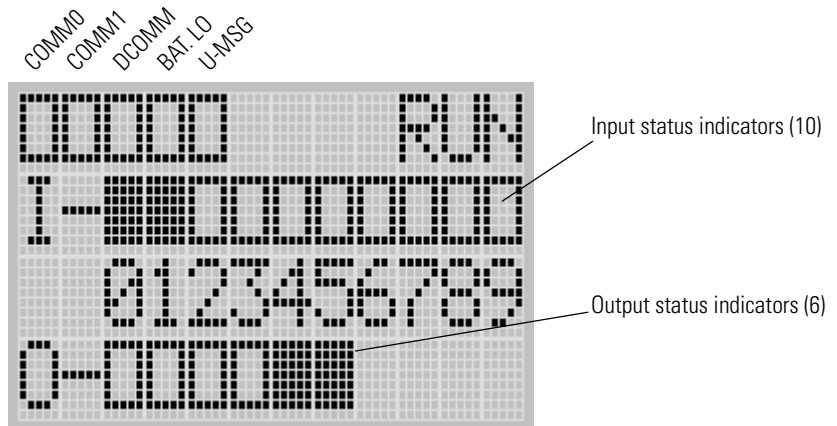

A solid rectangle is displayed when the input or output is energized. An empty rectangle is displayed when the input or output is not energized.

IMPORTANT

If no user defined LCD screen is used, the I/O Status screen is displayed,

- 5 seconds after the controller has powered-up.
- When the user enters the I/O Status screen from other screen using the LCD menu. If you are at other screen and want to view I/O status, you have to enter the I/O Status screen manually using the menu. Otherwise, the current screen will be displayed continuously.

IMPORTANT

If a user defined LCD screen is used, the I/O S
sctatus sreen is displayed,

- When the user holds down the ESC key for more than 3 seconds.
- When time out is enabled, i.e., the time out period is set to a positive value, and the time out period is passed. You can enable and disable time out and set the time out period using the TO element in the LCD Function File. For more information, refer to the LCD Function File described in the *MicroLogix 1100 Programmable Controllers Instruction Set Reference Manual*, publication 1763-RM001.
- If time out is disabled, i.e., the time out period is set to zero (0), and a custom LCD screen is displayed, it will be displayed continuously until the user gives an input to change to other screen. For more information, see [Using a User Defined LCD Screen on page 5-126](#).

Viewing I/O Status

Follow these steps to view the status of inputs and outputs on the LCD.

1. On the Main Menu screen, select I/O Status by using the Up and Down keys on the LCD keypad, as shown below.

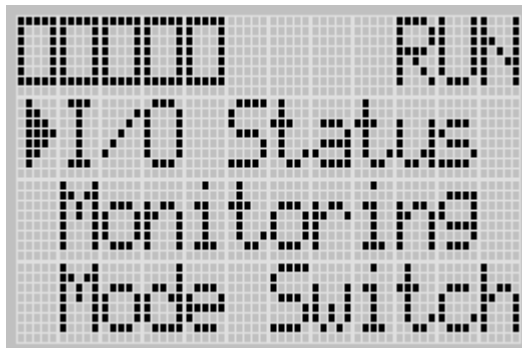

- Then, press the OK key on the LCD keypad. The I/O Status screen is displayed, as shown below.

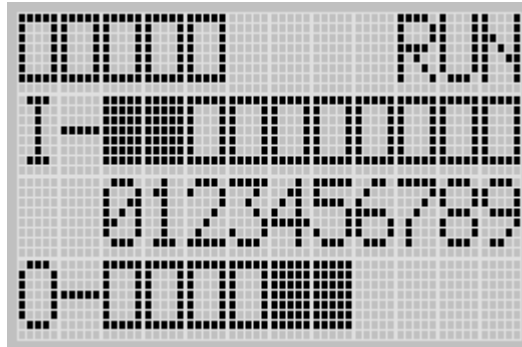

- If you have finished viewing I/O status, press the ESC key to return to the Main Menu screen, as shown in [step 1](#).

Monitoring Bit File

The LCD allows you to view and change the data values of 48 bits in a user defined file. You can access to this functionality via the Monitoring screen of the LCD.

To monitor the bit file on the LCD, you have to specify its file number in the Target Bit File Number (TBF) element of the LCD Function File and download your application program to the controller. The TBF element can only be changed by a program download.

Target Bit File Number (TBF)

Feature	Address	Data Format	Type	User Program Access
Target Bit File Number	LCD:0.TBF	Word (int)	Control	Read Only

The value stored in the TBF element identifies the bit file with which the LCD will interface. Valid bit files are B3, and B10 through B255. When the LCD reads a valid bit file number, it can access up to the first 48 bits (0 to 47) of the specified file on the LCD screen. The next 48 bits in the target bit file (48 to 95) are used to define the read-only or read/write privileges for the first 48 bits.

The only bit file that the LCD interfaces with is the file specified in the TBF element.

IMPORTANT

Use your programming software to ensure that the bit file you specify in the TBF element, as well as the appropriate number of elements, exist in the MicroLogix 1100 user program.

The example table below shows how the LCD uses the configuration information with bit file number 3 (LCD:0.TBF=3).

Bit Number	Data Address	Protection Bit	Bit Number	Data Address	Protection Bit	Bit Number	Data Address	Protection Bit
0	B3:0/0	B3:3/0	16	B3:1/0	B3:4/0	32	B3:2/0	B3:5/0
1	B3:0/1	B3:3/1	17	B3:1/1	B3:4/1	33	B3:2/1	B3:5/1
2	B3:0/2	B3:3/2	18	B3:1/2	B3:4/2	34	B3:2/2	B3:5/2
3	B3:0/3	B3:3/3	19	B3:1/3	B3:4/3	35	B3:2/3	B3:5/3
4	B3:0/4	B3:3/4	20	B3:1/4	B3:4/4	36	B3:2/4	B3:5/4
5	B3:0/5	B3:3/5	21	B3:1/5	B3:4/5	37	B3:2/5	B3:5/5
6	B3:0/6	B3:3/6	22	B3:1/6	B3:4/6	38	B3:2/6	B3:5/6
7	B3:0/7	B3:3/7	23	B3:1/7	B3:4/7	39	B3:2/7	B3:5/7
8	B3:0/8	B3:3/8	24	B3:1/8	B3:4/8	40	B3:2/8	B3:5/8
9	B3:0/9	B3:3/9	25	B3:1/9	B3:4/9	41	B3:2/9	B3:5/9
10	B3:0/10	B3:3/10	26	B3:1/10	B3:4/10	42	B3:2/10	B3:5/10
11	B3:0/11	B3:3/11	27	B3:1/11	B3:4/11	43	B3:2/11	B3:5/11
12	B3:0/12	B3:3/12	28	B3:1/12	B3:4/12	44	B3:2/12	B3:5/12
13	B3:0/13	B3:3/13	29	B3:1/13	B3:4/13	45	B3:2/13	B3:5/13
14	B3:0/14	B3:3/14	30	B3:1/14	B3:4/14	46	B3:2/14	B3:5/14
15	B3:0/15	B3:3/15	31	B3:1/15	B3:4/15	47	B3:2/15	B3:5/15

The bit number displayed on the LCD corresponds to the data address as illustrated in the table. The protection bit defines whether the data is editable or read-only. When the protection bit is set (1), the corresponding data address is considered read-only by the LCD. The “Protected!” message is displayed whenever a read-only element is active on the LCD. When the protection bit is clear (0) or the protection bit does not exist, no additional message is displayed and the data within the corresponding address is editable from the LCD keypad.

IMPORTANT

Although the LCD does not allow protected data to be changed from its keypad, the control program or other communication devices do have access to this data. Protection bits only provide LCD write protection. They do not provide any overwrite protection to data from ladder logic, HMI, or programming software. It is the users responsibility to ensure that data is not inadvertently overwritten.

TIP

- Remaining addresses within the target file can be used without restrictions (addresses B3:6/0 and above, in this example).
- The LCD always starts at bit 0 of a data file. It cannot start at any other address within the file.

Monitoring a Bit File

For explanations in this section, we assume the followings in the application program:

- A bit file B3, which is 7 elements long (7 words = 112 bits), is defined with the preset data, as shown in the screen capture below.

Offset	15	14	13	12	11	10	9	8	7	6	5	4	3	2	1	0
B3:0	0	0	0	0	0	0	0	0	0	0	0	0	1	0	0	0
B3:1	0	0	0	0	0	0	0	0	0	1	0	0	0	0	0	0
B3:2	0	0	0	0	0	0	0	0	0	0	0	0	0	0	0	0
B3:3	0	0	0	0	0	0	0	0	0	0	0	1	0	1	0	0
B3:4	0	0	0	0	0	0	0	0	1	0	0	0	0	0	0	0
B3:5	0	0	0	0	0	0	0	0	0	0	0	0	0	0	0	0
B3:6	0	0	0	0	0	0	0	0	0	0	0	0	0	0	1	0

data bits (first 48 bits), which are monitored on the LCD and maskable by protection bits

protection bits (second 48 bits)

data bits (after the first 96 bits), which are not monitored on the LCD and not maskable by protection bits

- The TBF element of the LCD Function File is set to 3 to specify the bit file B3 as the target bit file to monitor on the LCD, as shown in the screen capture below.

Address	Value	Description
LCD:0	{...}	
- CBS - Customized Boot Message String File Address Offset	0	
- SCD - Start with Customized Display	0	
- TO - Data Input Timeout of LCD Instruction(x Sec)	0	
- DN - LCD Instruction Job Done	1	
- ERR - LCD Display Operation Error Bit	0	
- ERN - LCD Module Operation Error Number	0	
- TBF - Target Bit File Number	3	
- TIF - Target Integer File Number	7	
- JOG - Jog data update Mode Set	0	
- TMIN - Trimpot Low Value	0	
- TMAX - Trimpot High Value	250	
- POT0 - Trimpot 0 Data (TMIN - TMAX)	0	
- POT1 - Trimpot 1 Data (TMIN - TMAX)	0	
- WND - Instruction Display Window	0	
- OK - OK key in Customized Display	0	
- ESC - ESC key in Customized Display	0	

- The controller mode is set to REMOTE RUN.

Follow these steps to view and change the data values of the bit file B3.

1. On the Main Menu screen, select Monitoring by using the Up and Down keys on the LCD keypad.

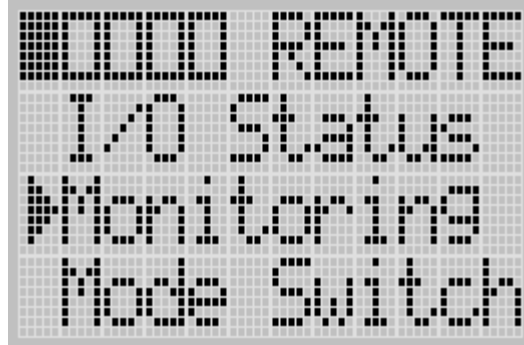

2. Then, press the OK key on the LCD keypad. The Bit/Integer File Select screen is displayed, as shown below.



3. If Bit is selected, as shown in [step 2](#), press the OK key. If not selected, press the Up or Down key to select it and then press the OK key.
4. The current data value (ON) of the B3:0/0 bit is displayed, as shown below. Note that "0/0" is flashing, which means the cursor is at the target bit position.



5. We will change the data value of the B3:0/0 bit to OFF (0).
First, press OK to select the displayed address and move the cursor to the data value position. Then, “ON” will be flashing, which means the cursor is at the data value position.
6. Press the Down key. Then, the data value will be represented as “OFF”.
Note that “OFF” is still flashing, which means the cursor is still at the data value position.
7. Press OK to apply the changes. Then, the new value OFF (0) is applied.
Note that the target bit, “0/0” in this example, is flashing. The cursor is moved automatically to the target bit position.



You can identify this change of data value is reflected to your RSLogix 500 programming software.

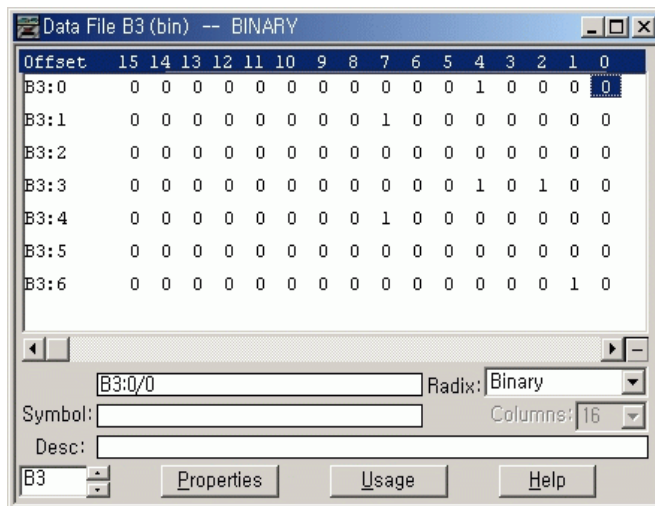

TIP

When the cursor is at the data value position, press the Down key to change the data value of a bit from ON (1) to OFF (0). Press the Up key to change from OFF (0) to ON (1).

After changing the data value of a target bit, press the OK key to apply the changes or press the ESC key to discard the changes.

8. Now, we will view an example of the data value of a protected bit, B3:0/2. Press the Up key twice. Then, the target bit will change to “0/2” and its data value is displayed with the “Protected!” message, as shown below. Because the B3:3/2 is set (1), the B3:0/2 bit is a protected bit.



9. Try to move the cursor to the data value position by pressing the OK key. Because the B3:0/2 bit is a protected bit, you will find that the cursor does not move to the data value position.
10. Press the Up key once to view the data value of the B3:0/3 bit. Because the B3:0/3 bit is not a protected bit, only its data value, OFF (0) in this example, is displayed without the “Protected!” message.
11. Press the Up key once to view the data value of the B3:0/4 bit. You will find that the B3:0/3 bit is a protected bit and its data value is ON (1).
12. Hold down the Up key until the target bit becomes “2/15”, as shown below.



Press the Up key again, and you will find the target bit does not change to “3/0”. It is because the maximum range of bits you can monitor with the LCD is the first 48 bits (3 words) of the specified target bit file.

IMPORTANT

The maximum range of bits you can monitor with the Bit File Monitoring functionality on the LCD is the first 48 bits (3 words).

13. Try to press the Up and Down keys to change the target bit to another bit. Try to change its data value using the OK, Up and Down keys.
14. If you have finished monitoring the bit file, B3, press the ESC key to return to the Bit/Integer File Select screen, as shown in [step 2](#).

Monitoring Integer File

The LCD allows you to view and change the data value of an integer file. You can access to this functionality via the Monitoring screen of the LCD.

To monitor an integer file on the LCD, you have to specify its file number in the Target Integer File Number (TIF) element of the LCD Function File and download your application program to the controller. The TIF element can only be changed by a program download.

Target Integer File Number (TIF)

Feature	Address	Data Format	Type	User Program Access
Target Integer File Number	LCD:0.TIF	Word (int)	Control	Read Only

The value stored in the TIF element identifies the integer file with which the LCD will interface. The LCD can read or write to any valid integer file within the controller. Valid integer files are N3 through N255. When the LCD reads a valid integer file number, it can access up to the first 48 elements (words 0 to 47) of the specified file on the LCD screen. The next 48 bits (words 48 to 50) are used to define the read-only or read/write privileges for the first 48 elements.

The only integer file that the LCD interfaces with is the file specified in the TIF element.

IMPORTANT

Use your programming software to ensure that the integer file you specify in the TIF element, as well as the appropriate number of elements, exist in the MicroLogix 1100 user program.

The example table below shows how the LCD uses the configuration information with integer file number 7 (LCD:0.TIF=7).

Element Number	Data Address	Protection Bit	Element Number	Data Address	Protection Bit	Element Number	Data Address	Protection Bit
0	N7:0	N7:48/0	16	N7:16	N7:49/0	32	N7:32	N7:50/0
1	N7:1	N7:48/1	17	N7:17	N7:49/1	33	N7:33	N7:50/1
2	N7:2	N7:48/2	18	N7:18	N7:49/2	34	N7:34	N7:50/2
3	N7:3	N7:48/3	19	N7:19	N7:49/3	35	N7:35	N7:50/3
4	N7:4	N7:48/4	20	N7:20	N7:49/4	36	N7:36	N7:50/4
5	N7:5	N7:48/5	21	N7:21	N7:49/5	37	N7:37	N7:50/5
6	N7:6	N7:48/6	22	N7:22	N7:49/6	38	N7:38	N7:50/6
7	N7:7	N7:48/7	23	N7:23	N7:49/7	39	N7:39	N7:50/7
8	N7:8	N7:48/8	24	N7:24	N7:49/8	40	N7:40	N7:50/8
9	N7:9	N7:48/9	25	N7:25	N7:49/9	41	N7:41	N7:50/9
10	N7:10	N7:48/10	26	N7:26	N7:49/10	42	N7:42	N7:50/10
11	N7:11	N7:48/11	27	N7:27	N7:49/11	43	N7:43	N7:50/11
12	N7:12	N7:48/12	28	N7:28	N7:49/12	44	N7:44	N7:50/12
13	N7:13	N7:48/13	29	N7:29	N7:49/13	45	N7:45	N7:50/13
14	N7:14	N7:48/14	30	N7:30	N7:49/14	46	N7:46	N7:50/14
15	N7:15	N7:48/15	31	N7:31	N7:49/15	47	N7:47	N7:50/15

The element number displayed on the LCD corresponds to the data address as illustrated in the table. The protection bit defines whether the data is editable or read-only. When the protection bit is set (1), the corresponding data address is considered read-only by the LCD. The “Protected!” message is displayed whenever a read-only element is active on the LCD. When the protection bit is clear (0) or the protection bit does not exist, no additional message is displayed and the data within the corresponding address is editable from the LCD keypad.

IMPORTANT

Although the LCD does not allow protected data to be changed from its keypad, the control program or other communication devices do have access to this data. Protection bits do not provide any overwrite protection to data within the target integer file. It is entirely the user’s responsibility to ensure that data is not inadvertently overwritten.

TIP

- Remaining addresses within the target file can be used without restrictions (addresses N7:51 and above, in this example).
- The LCD always starts at word 0 of a data file. It cannot start at any other address within the file.

Monitoring an Integer File

For explanations in this section, we assume the followings in the application program:

- An integer file N7, which is 53 elements long (53 words), is defined with the preset data, as shown in the screen capture below.

data words (first 48 words), which are monitored on the LCD and maskable by protection bits

protection bits (second 48 bits = 3 words)

data words (after the first 51 words), which are not monitored on the LCD and not maskable by protection bits

Offset	0	1	2	3	4	5	6	7	8	9	10	11	12	13	14	15
N7:0	0	2714	0	0	0	0	0	0	0	0	0	0	0	0	0	15
N7:16	0	0	3000	0	0	0	0	0	0	0	0	0	0	0	0	15
N7:32	0	1	2	3	4	5	6	7	8	9	10	11	12	13	14	15
N7:48	2	0	-1	0	0											

- The TIF element of the LCD Function File is set to 7 to specify the integer file N7 as the target integer file to monitor on the LCD, as shown in the screen capture below.

Address	Value	Description
- CBS - Customized Boot Message String File Address Offset	{...}	
- SCD - Start with Customized Display	0	
- TO - Data Input Timeout of LCD Instruction(x Sec)	0	
- DN - LCD Instruction Job Done	1	
- ERR - LCD Display Operation Error Bit	0	
- ERN - LCD Module Operation Error Number	0	
- TBF - Target Bit File Number	3	
- TIF - Target Integer File Number	7	
- JOG - Jog data update Mode Set	0	
- TMIN - Trimpot Low Value	0	
- TMAX - Trimpot High Value	250	
- POT0 - Trimpot 0 Data (TMIN - TMAX)	0	
- POT1 - Trimpot 1 Data (TMIN - TMAX)	0	
- WND - Instruction Display Window	0	
- OK - OK key in Customized Display	0	
- ESC - ESC key in Customized Display	0	

- The controller mode is set to REMOTE RUN.

Follow these steps to view and change the data values of the integer file N7.

1. On the Main Menu screen, select Monitoring by using the Up and Down keys on the LCD keypad.

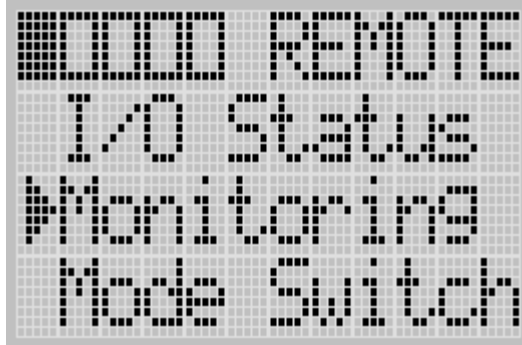

2. Then, press the OK key on the LCD keypad. The Bit/Integer File Select screen is displayed, as shown below.

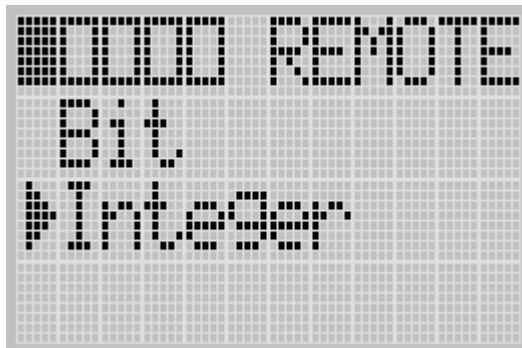

3. If Integer is selected, as shown in step 2, press the OK key. If not selected, press the Down key to select it and then press the OK key.
4. The current data value (ON) of the N7:0 word is displayed, as shown below. Note that the target word "0", which is right to "N7:", is flashing, which means the cursor is at the target word position.

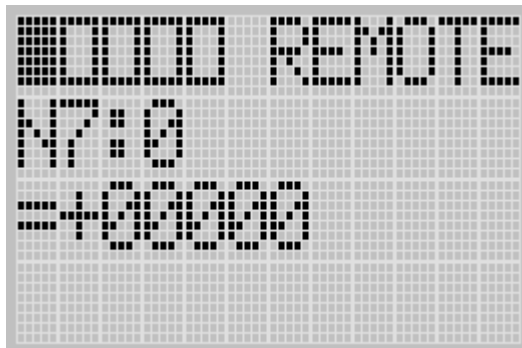

5. We will change the data value of the N7:0 word to the negative decimal value -1300. First, press OK to move the cursor to the data value position. Then, the last digit of “+00000” will be flashing, which means the cursor is at the data value position.
6. Press the Left key twice. Then, the cursor will position at the third digit. Press the Up key three times to change the third digit to 3.



7. Press the Left key once. Then, press the Up key once. The second digit will change to “1”. Note that “1” is still flashing, which means the cursor is still at the data value position.



8. Press the Left key once. Then, press the Down key once. The sign digit will change to “-”, as shown below. Note that “-” is still flashing, which means the cursor is still at the data value position.



- Press OK to apply the changes. Then, the new value -1300 is applied. Note that the target word “0”, which is right to “N7:”, is flashing. The cursor is moved automatically to the target word position.

You can identify this change of data value is reflected to your RSLogix 500 programming software, as shown below.

Offset	0	1	2	3	4	5	6	7	8	9	10	11	12	13	14	15
N7:0	-1300	2714	0	0	0	0	0	0	0	0	0	0	0	0	0	15
N7:16	0	0	3000	0	0	0	0	0	0	0	0	0	0	0	0	15
N7:32	0	1	2	3	4	5	6	7	8	9	10	11	12	13	14	15
N7:48	2	0	-1	0	0											

TIP

After changing the data value of a target word, press the OK key to apply the changes or press the ESC key to discard the changes.

- Now, we will view the data value of a protected word N7:1. Press the Up key once. Then, the target word will change to “1” and its data value is displayed with the “Protected!” message, as shown below. Because the N7:48/1 bit is set (1), the N7:1 word is a protected word.

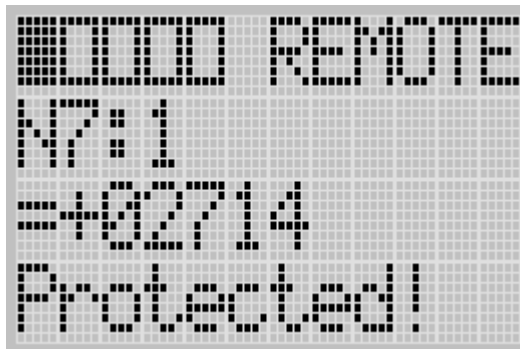

- Try to move the cursor to the data value position by pressing the OK key. Because the N7:1 word is protected, you will find that the cursor even does not move to the data value position.
- Press the Up key once to view the data value of the N7:2 word. Because the N7:2 word is not protected, only its data value, 0 in this example, is displayed without the “Protected!” message.

13. Hold down the Up key until the target word becomes “47”, as shown below.

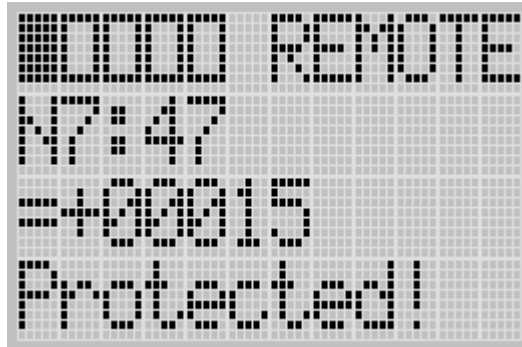

Press the Up key again, and you will find the target word does not change to “48”. It is because the maximum range of words you can monitor with the LCD is the first 48 words of the specified target integer file.

IMPORTANT

The maximum range of words you can monitor with the Integer File Monitoring functionality on the LCD is the first 48 words (0 through 47) of the target integer file.

14. Try to press the Up and Down keys to change the target word to another word. Try to change its data value using the OK, Up, Down, Right and Left keys.
15. If you have finished monitoring the integer file N7, press the ESC key to return to the Main Menu screen, as shown in [step 2](#).

Using the Mode Switch

The MicroLogix 1100 provides the controller mode switch on the LCD. The possible positions of the mode switch are PROGRAM, REMOTE, and RUN. You can change mode switch position using the Mode Switch screen on the LCD, as shown below. In this example, the mode switch position is set to REMOTE.



All the built-in LCD screens except the Boot Message screen display *the current mode switch position*, at their top right portion, as shown below. In this example, the mode switch position is set to RUN.

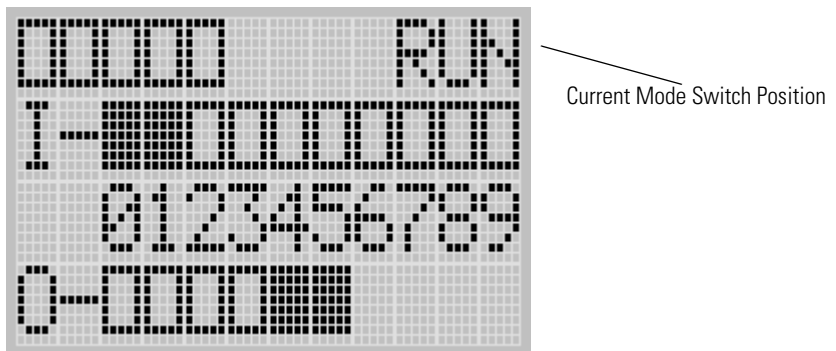

Controller Modes

The table below shows the possible controller modes when the mode switch positions at PROGRAM, REMOTE, or RUN. For example, if the Mode Switch is at RUN and you want to test a control program with running it for a single scan, you have to first change mode switch position to REMOTE before you run the control program in the remote test single scan mode with your RSLogix 500 programming software.

Possible Controller Modes by Mode Switch Position

When the Mode Switch Positions at	Possible Controller Modes are
PROGRAM	download in progress
	program mode
	suspend mode (operation halted by execution of the SUS instruction)
REMOTE	remote download in progress
	remote program mode
	remote suspend mode (operation halted by execution of the SUS instruction)
	remote run mode
	remote test continuous mode
	remote test single scan mode
RUN	run mode

Changing Mode Switch Position

Mode Switch position can be changed at two different times using LCD keypad. One is when the controller is powered up, and the other is while the controller is powered on.

Mode Switch position can be set to either PROG or RUN when the controller is powered up. This allows the controller operation which is different from the previous mode, that is, any program under RUN before can be stopped or any new program can be run when the controller is powered up.

- How to forcibly set Mode Switch to RUN when the controller is powered up

Press OK key for 5 seconds when the controller is powered up. The following LCD screen appears if it's successfully done.

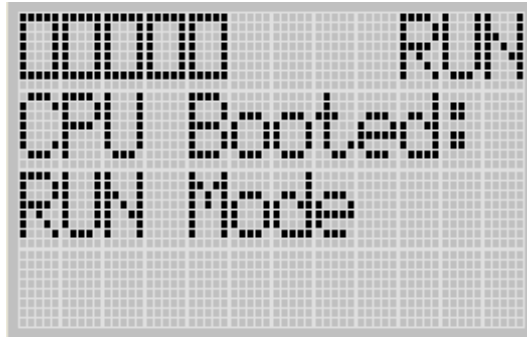

- How to forcibly set Mode Switch to PROG when the controller is powered up

Press ESC key for 5 seconds when the controller is powered up. The following LCD screen appears if it's successfully done.



Note that I/O output status may be changed for some programs.

While the controller is powered on, follow these steps to change the position of the Mode Switch.

1. On the Main Menu screen, select Mode Switch by using the Up and Down keys on the LCD keypad.

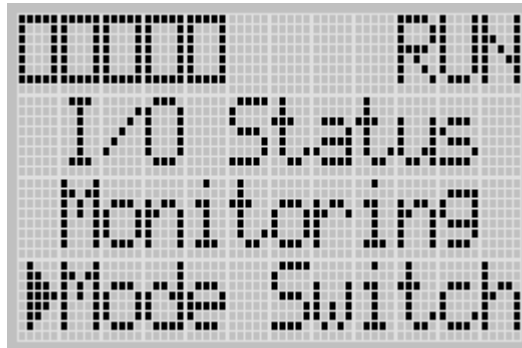

2. Then, press the OK key on the LCD keypad. The Mode Switch screen is displayed, as shown below.

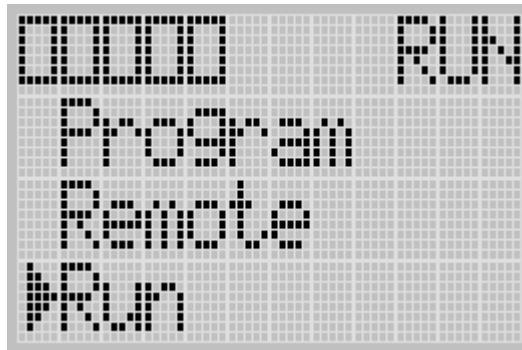

The arrow indicates current Mode Switch position.

3. When the Up or Down key is pressed, the mode indicated by the arrow starts to blink if the mode is different from the current mode of controller. Press OK key to set the controller to the mode indicated by the arrow.
4. If you have finished changing mode switch position, press the ESC key to return to the Main Menu screen, as shown in [step 1](#).

Using a User Defined LCD Screen

The MicroLogix 1100 controller allows you to use user defined LCD screens instead of the default built-in screens.

To use a user defined screen, you need to create a group of appropriate instructions using the LCD instruction in your application program. For more information on how to create a user defined LCD screen, refer to the MicroLogix 1100 Programmable Controllers Instruction Set Reference Manual, publication 1763-RM001.

By using the User Displ menu item, you can change from the default built-in screens to a user defined screen and back on the LCD.

User Defined LCD Screen

Follow these steps to display the user defined screen implemented in your application program.

1. On the Main Menu screen, select User Displ by using the Up and Down keys on the LCD keypad, as shown below. If the menu items shown in the figure below are not displayed on the Main Menu screen, you need to scroll down the screen by pressing the Down key.



2. Then, press the OK key on the LCD keypad.

If no user defined screen is used in your application program, the screen is displayed, as shown below.

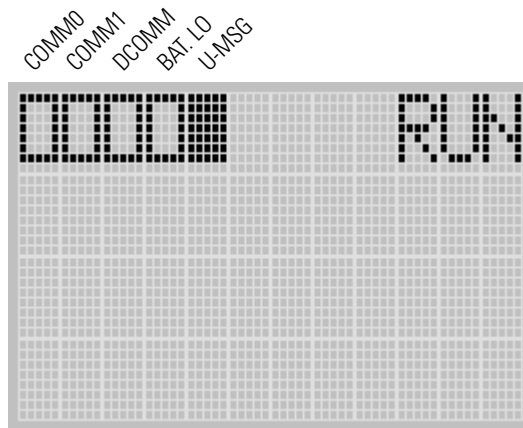

Note that the U-MSG indicator on the top of the LCD is displayed in solid rectangle. It means the LCD is in User Defined LCD mode.

If a user defined screen is used in your application program, the LCD screen is displayed, as shown below, according to the specific instructions used in your program.



3. Hold down the ESC key **more than 3 seconds** to return to the Main Menu screen, as shown below.

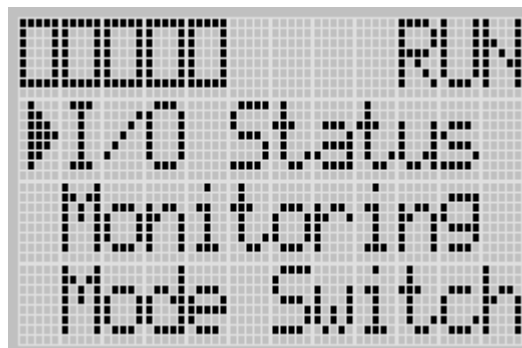

Configuring Advanced Settings

With the Advanced Settings menu, which is a sub-menu under the main menu of the LCD, you can use the following features:

- changing Key In mode
- using communications toggle functionality
- viewing Ethernet port configuration
- using trim pots
- viewing system information
- viewing fault code

You can access to the Advanced Settings Menu screen, as shown below, by selecting Advance Set on the Main Menu screen.

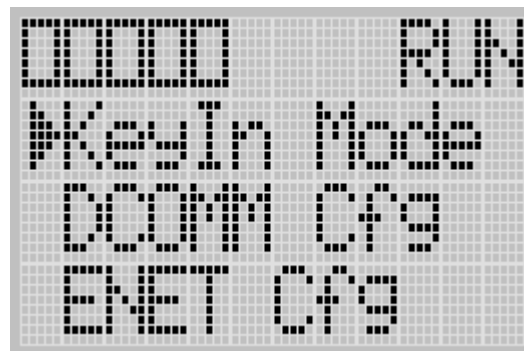

Changing Key In Mode

Key In Modes

There are two Key In modes, Continuous and Discrete.

TIP

The Key In mode has effect only when you change the data value of a trim pot on a Trim Pot screen, either Trim Pot 0 or Trim Pot 1 screen. For more information on how to change the data value of a trim pot, see [Changing Data Value of a Trim Pot on page 5-133](#).

The current Key In mode determines how the value changes are applied when you press the Up and Down keys to change the data value for a trim pot. When set to Continuous, the changes are applied immediately whenever you press the Up and Down keys. When set to Discrete, the changes are applied only when you press the OK key after you have changed the value using the Up and Down keys.

By using the Key In Mode screen, as shown below, you can change the Key In mode to use.



Changing Key In Mode

Follow these steps to change the current Key In mode.

1. On the Main Menu screen, select Advance Set by using the Up and Down keys on the LCD keypad, as shown below. If the menu items shown in the figure below are not displayed on the Main Menu screen, you need to scroll down the screen by pressing the Down key.

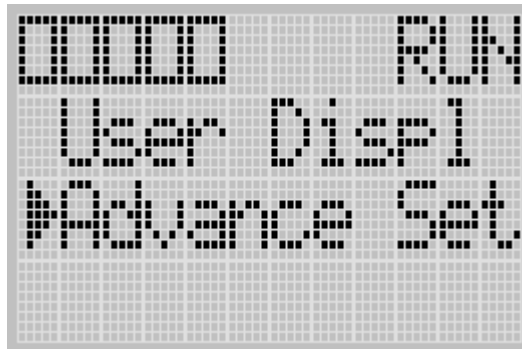

2. Then, press the OK key on the LCD keypad. The Advanced Settings Menu screen is displayed, as shown below.

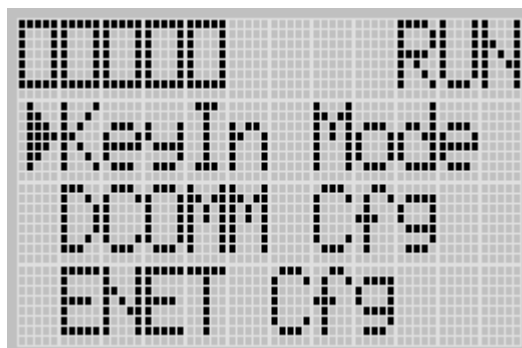

3. Select KeyIn Mode using the Up and Down keys, and then press the OK key.
4. The Key In Mode screen is displayed, as shown below. The current mode, Continuous in this example, is selected marked up with the symbol “▶”.

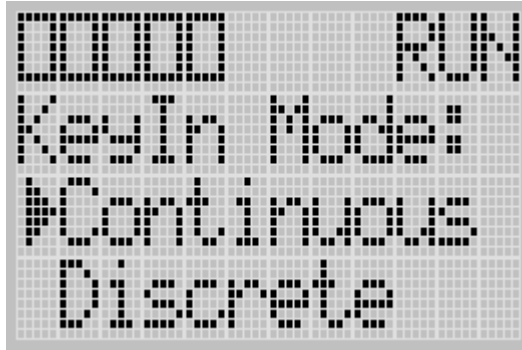

5. Press the Up or Down key to select the different mode, Discrete in this example, as shown below. Then, press the OK key.

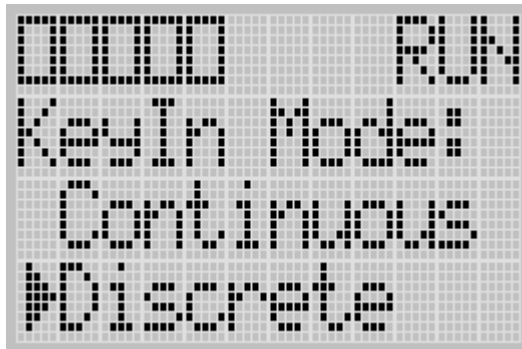

6. The Key In Mode Change Notification screen is displayed, as shown below.

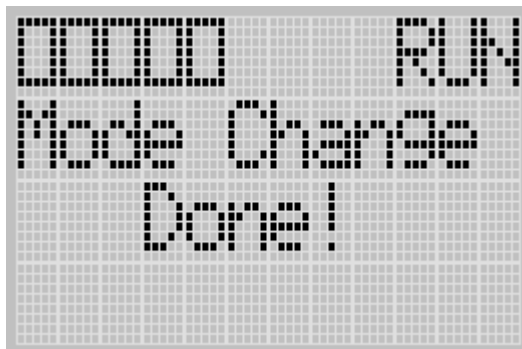

7. Press the ESC key to return to the Advanced Settings Menu screen, as shown in [step 2](#).

Using Communications Toggle Functionality

The MicroLogix 1100 provides the Communications Toggle Functionality, which allows you to change from the user-defined communication configuration to the default communications mode and back to the user defined communication configuration on Channel 0.

See [Using the Communications Toggle Functionality on page 4-72](#) for information about how to use the Communications Toggle Functionality.

Viewing Ethernet Port Configuration

The Ethernet Port Configuration screen of the LCD displays the MAC and IP addresses assigned to the controller.

Follow these steps to view the Ethernet port configuration for your controller.

1. On the Main Menu screen, select Advance Set by using the Up and Down keys on the LCD keypad, as shown below. If the menu items shown in the figure below are not displayed on the Main Menu screen, you need to scroll down the screen by pressing the Down key.



2. Then, press the OK key on the LCD keypad. The Advanced Settings Menu screen is displayed, as shown below.

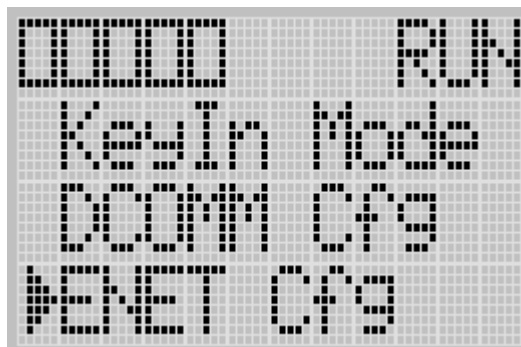

3. If ENET Cfg is selected, press the OK key. If not, select ENET Cfg using the Up and Down keys, and then press the OK key.
4. The Ethernet Port Configuration screen is displayed.

When an IP address is not yet assigned to your controller, only the MAC address assigned to your controller, which is represented as XXXXXXXXXXXX below, is displayed.

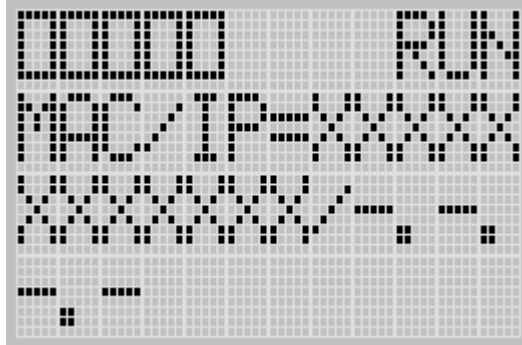

A MAC address is a 12-digit hexadecimal number. Your controller ships with a unique MAC address assigned in factory. You can identify the MAC address of your controller by opening the expansion module cover on your controller.

When an IP address is assigned to your controller, both of MAC address and IP address of your controller are displayed, as shown below. In this example, the MAC address is represented as XXXXXXXXXXXX, which is a 12-digit hexadecimal number. The IP address is represented as xxx.xxx.xxx.xxx, where each xxx is a decimal number between 0-255.

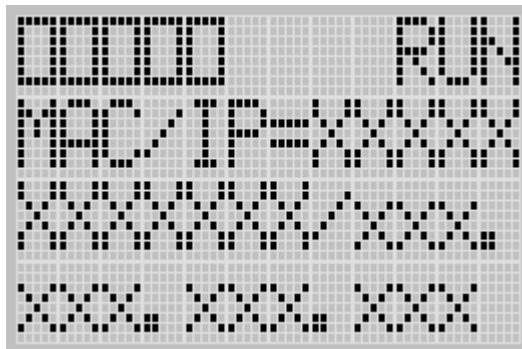

5. Press the ESC key to return to the Advanced Settings Menu screen, as shown in [step 2](#).

Using Trim Pots

Trim Pot Operation

The MicroLogix 1100 controller provides two trimming potentiometers (trim pots, POT0 and POT1) which allow modification of integer data within the controller. The data value of each trim pot can be used throughout the control program for timers, counters, analog presets, etc. depending upon the requirements of the application.

You can change the data value of each trim pot using the trim pot screens provided by the LCD. To access to the Trim Pot Set screen, which is the top screen for the trim pot functionality, select TrimPot Set on the LCD default menu screen, as shown below, and press the OK key on the LCD keypad.

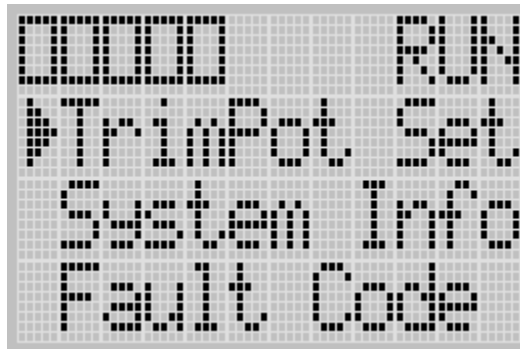

Trim pot data is updated continuously whenever the controller is powered-up.

Changing Data Value of a Trim Pot

Follow these steps to change the data value of a trim pot, either POT0 or POT1.

1. On the Main Menu screen, select TrimPot Set by using the Up and Down keys on the LCD keypad.

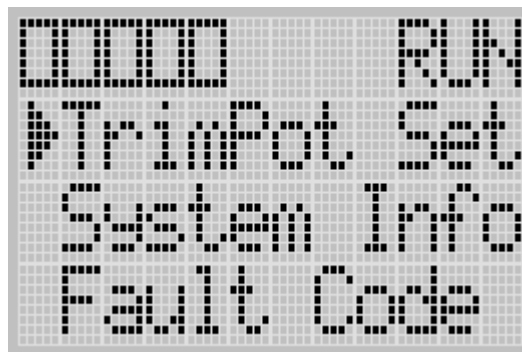

- Then, press the OK key on the LCD keypad. The Trim Pot Select screen is displayed, as shown below.

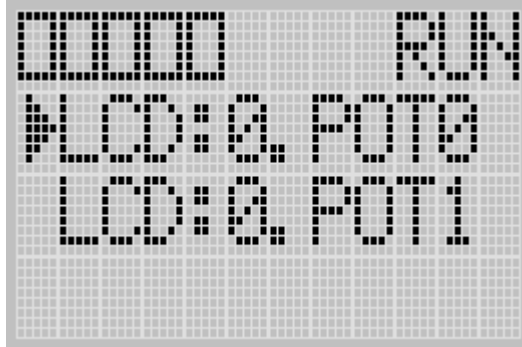

The last trim pot whose data value you changed is selected by default. If you are accessing to this screen for the first time, POT0 is selected by default.

- Select a trim pot, either POT0 or POT1, whose data value you want to change using the Up and Down keys on the LCD keypad. In this example, we will select POT0.
- Then, press the OK key on the LCD keypad. The Trim Pot 0 screen is displayed, as shown below.

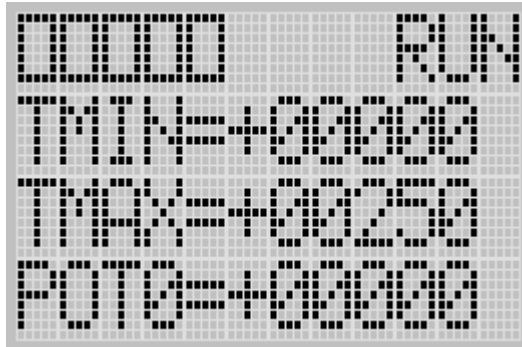

TMIN and TMAX indicate the range of data value for the trim pots, both POT0 and POT1. The factory default for TMIN, TMAX, and POT0 values are 0, 250, and 0 in decimal, respectively. TMIN and TMAX on this screen are read only, but you can change them using the LCD Function File in your application program. The TMIN and TMAX elements can only be changed by a program download.

For more information on how to change Trim Pot configuration including TMIN and TMAX, refer to the LCD Function File described in the *MicroLogix 1100 Programmable Controllers Instruction Set Reference Manual*, publication 1763-RM001.

IMPORTANT

The same TMIN and TMAX values are used for both trim pots, POT0 and POT1. This behavior is intended by design for simplicity in Trim Pot configuration.

When you enter this screen, the last digit of the POT0 value is flashing. It indicates the current digit. Press the Up and Down keys on the LCD keypad to change the value of the current digit. Press the Left and Right keys to select a different digit as the current digit.

If the Key In mode is set to Continuous, the changes are applied immediately after you press the Up and Down keys. While, if it is set to Discrete, you have to press the OK key to apply the changes after you change the data value. For more information on how to set the Key In mode, see [Changing Key In Mode on page 5-128](#).

TIP

The Key In mode has effect only when you change the data value of a trim pot on a Trim Pot screen, either the Trim Pot 0 or Trim Pot 1 screen.

5. If you have finished changing the data value of the selected trim pot, POT0 in this example, press the ESC key to return to the Trim Pot Select screen, as shown in [step 2](#).

Trim Pot Configuration in LCD Function File

The configuration for Trim Pots in the LCD Function File, including trim pot low and high values for data value range, is described in the *MicroLogix 1100 Programmable Controllers Instruction Set Reference Manual*, publication 1763-RM001.

Error Conditions

Error conditions regarding the Trim Pot functionality are described in the *MicroLogix 1100 Programmable Controllers Instruction Set Reference Manual*, publication 1763-RM001.

Viewing System Information

The System Information screen of the LCD allows you to identify the system information for your controller.

Follow these steps to view the system information for your controller.

1. On the Main Menu screen, select Advance Set by using the Up and Down keys on the LCD keypad, as shown below. If the menu items shown in the figure below are not displayed on the Main Menu screen, you need to scroll down the screen by pressing the Down key.

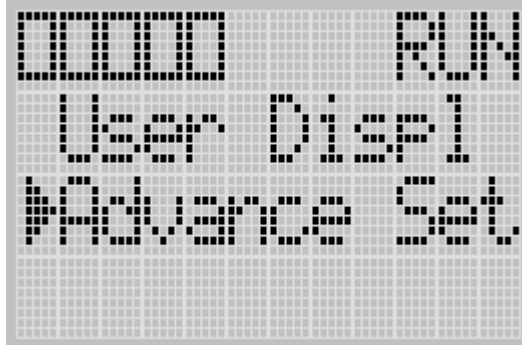

2. Then, press the OK key on the LCD keypad. The Advanced Settings Menu screen is displayed, as shown below.

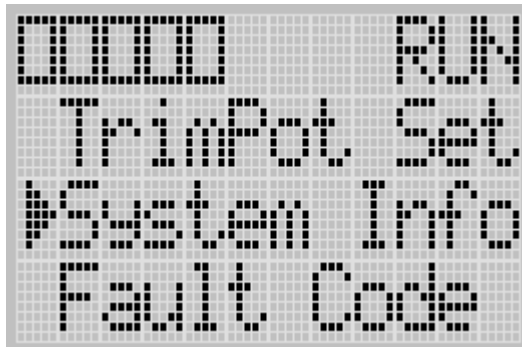

3. If System Info is selected, press the OK key. If not, select System Info using the Up and Down keys, and then press the OK key.

- The System Information screen is displayed.

You can identify the catalog number, operating system firmware revision number, and boot firmware revision number of your controller.

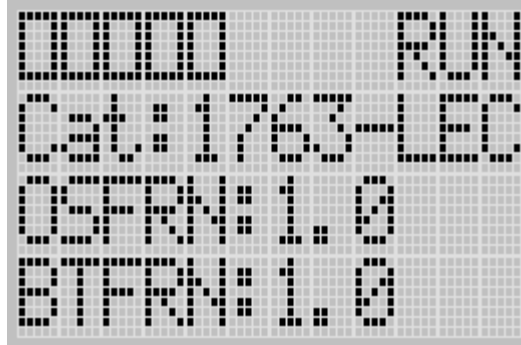

- Press the ESC key to return to the Advanced Settings Menu screen, as shown in [step 3](#).

Viewing Fault Code

The Fault Code screen of the LCD displays the fault code when a fault occurs.

When a fault occurs, the Fault Code screen is not displayed automatically. Only the FAULT LED on the controller flashes in red light. Therefore, you need to navigate into the Fault Code screen to identify the fault code on the LCD.

Follow these steps to view the fault code when a fault occurs.

- On the Main Menu screen, select Advance Set by using the Up and Down keys on the LCD keypad, as shown below. If the menu items shown in the figure below are not displayed on the Main Menu screen, you need to scroll down the screen by pressing the Down key.



- Then, press the OK key on the LCD keypad. The Advanced Settings Menu screen is displayed, as shown below.

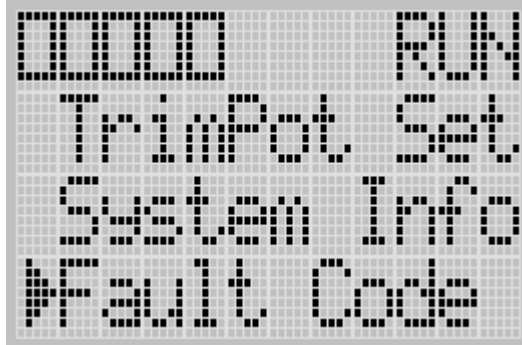

- If Fault Code is selected, press the OK key. If not, select Fault Code using the Up and Down keys, and then press the OK key.
- The Fault Code screen is displayed.

If no fault occurred, "0000h" is displayed, as shown below.

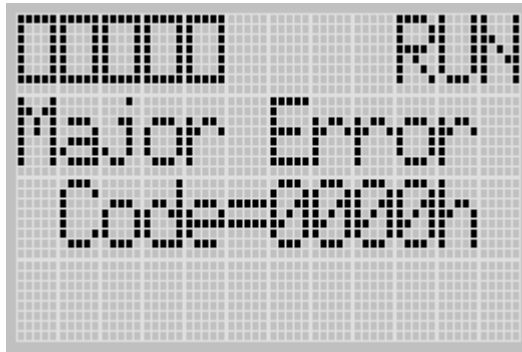

If a fault is occurred, its fault code is displayed, as shown below.

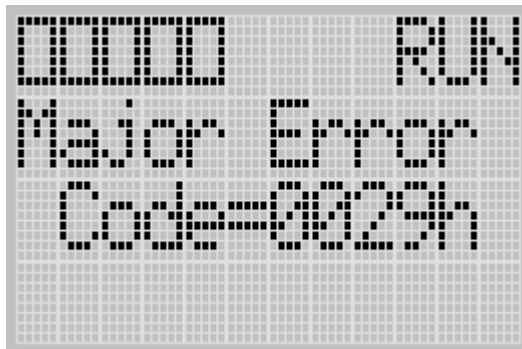

TIP

For more information on a specific fault code, refer to the *Online Help* of your RSLogix 500 programming software.

- Press the ESC key to return to the Advanced Settings Menu screen, as shown in [step 2](#).

Using Real-Time Clock and Memory Modules

The MicroLogix 1100 controller has a built-in real-time clock (RTC). You can order a memory module as an accessory.

TIP

For more information on “Real-Time Clock Function File” and “Memory Module Information File”, refer to the MicroLogix 1100 Programmable Controllers Instruction Set Reference Manual, publication 1763-RM001.

One type of memory module is available for use with the MicroLogix 1100 controller.

Catalog Number	Function	Memory Size
1763-MM1	Memory Module	128 KB

Real-Time Clock Operation

Operation at Power-up and Entering a Run or Test Mode

At power-up and when the controller enters a run or test mode, the values (date, time and status) of the RTC are written to the RTC Function File in the controller.

The following table indicates the accuracy of the RTC for various temperatures.

RTC Accuracy

Ambient Temperature	Accuracy ⁽¹⁾
0 °C (32 °F)	-13...-121 seconds/month
25 °C (77 °F)	54...-5 seconds/month
40 °C (104 °F)	29...-78 seconds/month
55 °C (131 °F)	-43...-150 seconds/month

⁽¹⁾ These numbers are maximum worst case values over a 31-day month.

Writing Data to the Real-Time Clock

When valid data is sent to the real-time clock from the programming device or another controller, the new values take effect immediately.

The real-time clock does not allow you to load or store invalid date or time data.

RTC Battery Operation

The real-time clock uses the same replaceable battery that the controller uses. The RTC Function File features a battery low indicator bit (RTC:0/BL), which shows the status of the replacement battery. When the battery is low, the indicator bit is set (1). This means that the battery wire connector could be disconnected or if the battery is connected, the battery may be ready to fail in the next two weeks. In the latter case, the replacement battery needs to be replaced with a new one. When the battery low indicator bit is clear (0), the battery level is acceptable.

The Battery Low (BAT.LO) indicator on the LCD display of the controller also shows the status of the replaceable battery. When the battery is low, the indicator is displayed as solid rectangle (■). When the battery level is acceptable, the indicator is displayed as empty rectangle (□), as shown below.

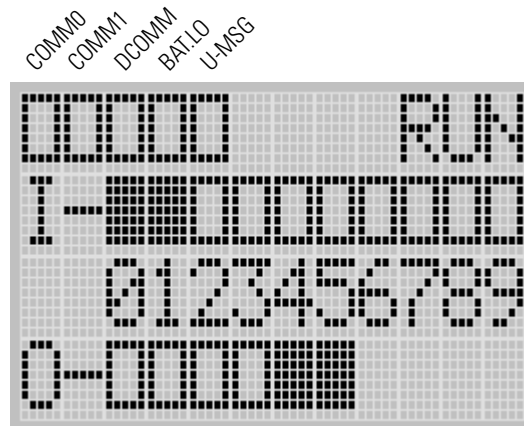

If the RTC battery is low and the controller is powered, the RTC operates normally. If the controller power is removed and the RTC battery is low, RTC data is lost.

ATTENTION



Operating with a low battery indication for more than 2 weeks (8 hours without a battery) may result in invalid RTC data unless power is on continuously.

Memory Module Operation

The memory module supports the following features:

- User Program, User Data and Recipe Back-up
- User Program Compare
- Data File Download Protection
- Memory Module Write Protection
- Removal/Insertion Under Power

ATTENTION



Electrostatic discharge can damage the Memory Module. Do not touch the connector pins or other sensitive areas.

User Program , User Data and Recipe Back-up

The memory module provides a simple and flexible program, data and recipe transport mechanism, allowing the user to transfer the program, data and recipe to the controller without the use of a personal computer and programming software.

The memory module can store one user program at a time.

During program transfers to or from the memory module, the controller's RUN LED flashes.

Program Compare

The memory module can also provide application security, allowing you to specify that if the program stored in the memory module does not match the program in the controller, the controller will not enter an executing (run or test) mode. To enable this feature, set the S:2/9 bit in the system status file. See "Status System File" in the *MicroLogix 1100 Programmable Controllers Instruction Set Reference Manual*, Publication 1763-RM001 for more information.

Data File Download Protection

The memory module supports data file download protection. This allows user data to be saved (not overwritten) during a download.

TIP

Data file download protection is only functional if the processor does not have a fault, size of all protected data files in the memory module exactly match the size of protected data files within the controller, and all protected data files are of the same type. See “Protecting Data Files During Download” in the *MicroLogix 1100 Programmable Controllers Instruction Set Reference Manual*, Publication 1763-RM001.

Memory Module Write Protection

The memory module supports write-once, read-many behavior. Write protection is enabled using your programming software.

IMPORTANT

Once set, write protection cannot be removed. A change cannot be made to the control program stored in a write protected memory module. If a change is required, use a different memory module.

Removal/Insertion Under Power

The memory module can be installed or removed at any time without risk of damage to either the memory module or the controller. If a memory module is installed while the MicroLogix 1100 is executing, the memory module is not recognized until either a power cycle occurs, or until the controller is placed in a non-executing mode (program mode, suspend mode or fault condition).

Memory Module Information File

The controller has a Memory Module Information (MMI) File which provides status from the attached memory module. At power-up or on detection of a memory module being inserted, the catalog number, series, revision, and type are identified and written to the MMI file. If a memory module is not attached, zeros are written to the MMI file. Refer to the *MicroLogix 1100 Instruction Set Reference Manual*, publication 1763-RM001, for more information.

Program /Data Download

To download the program and data from a memory module to the controller's memory, on the "Comms" menu in your RSLogix 500 programming software, point "EEPROM" and then click "Load from EEPROM".

TIP

For more information on program/data download, refer to your RSLogix 500 programming software documentation.

Program /Data Upload

To upload the program and data from the controller's memory to a memory module, on the "Comms" menu in your RSLogix 500 programming software, point "EEPROM" and then click "Store to EEPROM".

TIP

For more information on program/data upload, refer to your RSLogix 500 programming software documentation.

Notes:

Online Editing

The online editing function lets you monitor and modify your ladder program when your programming terminal is connected to a MicroLogix 1100 processor.

Overview of Online Editing

Online editing of ladder programs is available when using MicroLogix 1100 processors. Use this function to make changes to a pre-existing ladder program. Online editing functions consist of inserting, replacing, and deleting rungs in an existing ladder program while online with the processor.

Only one programming device can perform an online edit of a user program at a time. When an online editing session begins, an access from other programming devices will be rejected by MicroLogix 1100.

ATTENTION

Before initiating an online editing session, we recommend that you fully understand the possible results of the edit to the system under control. Failure to properly edit a running program could result in unexpected controller operation. Physical injury or equipment damage may result.

While three instructions, MSG, PTO, and PWM, are supported by program mode online edit, they are not supported by RUNTIME (RUN mode) online edit. Refer to the *MicroLogix™ 1100 Instruction Set Reference Manual*, publication 1763-RM001 for additional details.

The following table summarizes the differences between offline and online editing.

Offline	Online
No restrictions exist. Full editing capabilities are allowed.	Data table file resizing is not permitted.
	Program file creation and deletion are not permitted.
	Alteration of file protection is not permitted.
	Alteration of static and constant data file values is not permitted.
	Indexing across file boundary selections is not permitted.
	Force protection selection is not permitted.
	I/O configuration is not permitted.

IMPORTANT

It is important to keep in mind that some ladder instructions, when programmed online, cause data table values to change. These instructions are those that require timer, counter, and control addresses to be specified. This is discussed later in the chapter.

Online Editing Terms

The following terms are used throughout this chapter.

- **Assemble Edits** — Deletes any rungs marked with Delete or Replace edit zone markers during an online editing session. Inserted or modified rungs remain. All edit zone markers are removed when this function is complete.
- **Cancel Edits** — Deletes any inserted or modified rungs added during an online editing session. Rungs marked with Delete and Replace edit zone markers remain. All edit zone markers are removed when this function is complete.
- **Test Edits** — Allows you to verify that the changes you entered are not going to cause improper machine operation before you make the changes a permanent part of your ladder program.
- **Untest Edits** — Allows you to disable testing.
- **Edit Zone markers** — Appear on the power rail of the ladder program display. They indicate the type of edit taking place on the rung.
- **Accept Rung** — Incorporates the edits of a single rung into the ladder program.
- **online edit session** — begins when a user tries to edit rungs while online. Any other programming device that was monitoring the user program is removed from the program monitor display.

- **modify rung** — when an existing rung is modified two edit zones are created. The original rung is indicated by replace zone markers on the power rail. A copy of the original rung is made so you can insert, delete, or modify instructions. This rung is indicated by insert zone markers on the power rail. Thus, an IR pair is created when you modify a rung.
- **runtime online editing** — the user program is executing when an edit takes place. Any rungs that are inserted, modified, or deleted remain in the ladder program and are indicated by edit zone markers on the power rail. Edit zone markers remain after an action is completed.
- **program online editing** — the user program is not executing when an edit session begins. Any action that inserts, deletes, or modifies a rung takes place immediately.

The following figure shows the process involved when performing a runtime online edit.

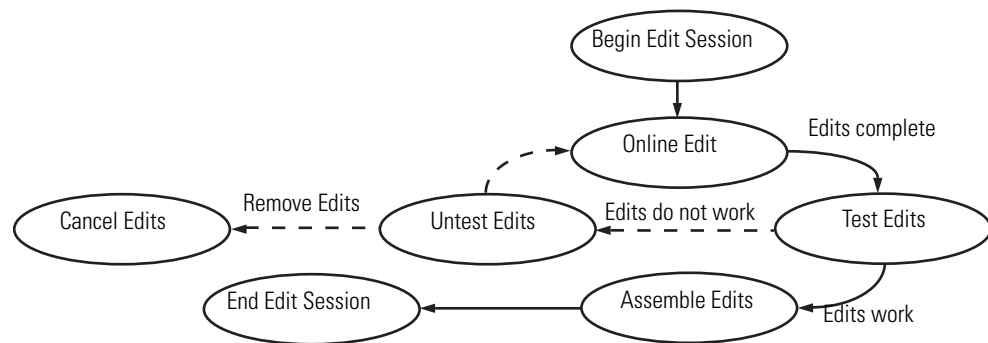

Effects of Online Editing On Your System

The following section covers the effects of online editing on your system. Keep these items in mind while using the online editing function.

System Impacts

The scan time and interrupt latency can be extended when accepting a rung, assembling, or canceling edits.

Memory limitations - Online edit can be performed until there is insufficient program memory available in the processor. Note that, before assemble edits, all the edited rungs are in the processor memory consuming memory, although they are not executed.

Data Table File Size

Online editing cannot change the *size* of existing data tables nor can new ones be created. However, some ladder instructions, when programmed cause data table *values* to change. These instructions are those that require timer, counter, and control addresses to be specified.

Online Edit Error

If either electrical interference, communication loss, or a power cycle occur during online edit session, program integrity may be impacted. In this case, the controller will generate the 1F fault code, clear the user program, and load the default program.

Directions and Cautions for MicroLogix 1100 Online Edit User

Change the RSLinx "Configure CIP Option" (OS Series A FRN 1,2, and 3 only)

Change the RSLinx "Configure CIP Option" to prevent ownership fault when MicroLogix 1100 is connected using RSLinx classic Ethernet/IP driver.

Several RSLogix 500 Online operations require obtaining the processor Edit Resource/Processor Ownership in order to ensure that one programming terminal has exclusive capability of performing any of these operations at a time. These operations include downloading, online editing, and applying channel configuration changes.

In addition to reducing the number of RSLinx Messaging Connections per PLC to one, it is also recommended that the Messaging Connection Retry

Interval be increased from the default of 1.25 seconds to 8 seconds as shown in the following figure.

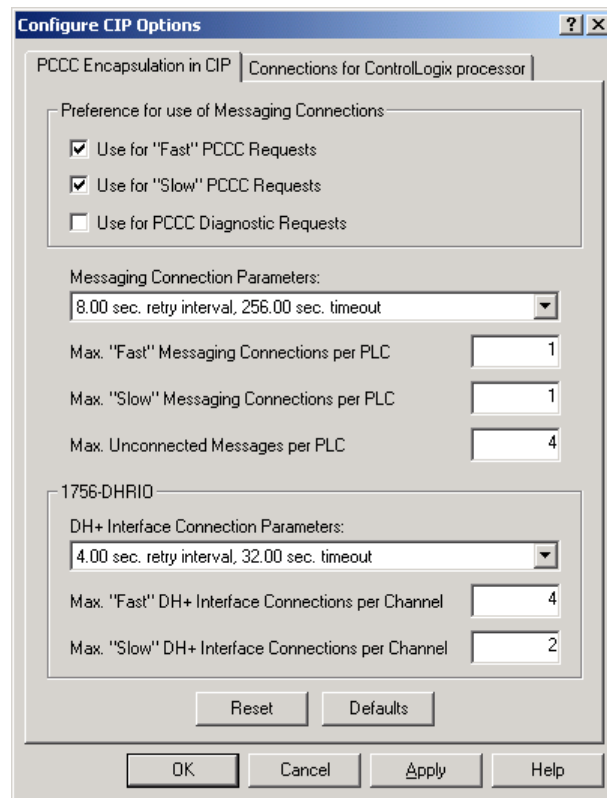

A Download Before Starting Online Edit

At least one download is required before starting online edit.

If you are using a MicroLogix 1100 from out-of-box state or after clear processor memory or firmware upgrade, at least one download is required before starting online edits. If not, the following error occurs and programming software will go offline due to default image mismatch between programming software (RSLogix500) and the MicroLogix 1100. You can also see the fault code 1Fh which is a user defined fault code.

In order to prevent this error, a user needs to download the program to the MicroLogix 1100, although the program is empty.

This problem happens only in out-of-box state or after clear processor memory.

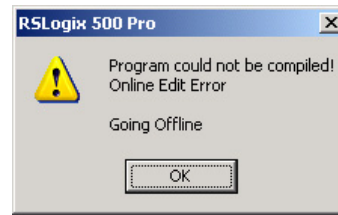
**ATTENTION**

PTO and PWM instructions may not be deleted during runtime online edit. This is because if the PTO or PWM instructions were deleted during runtime online edit, outputs could stop in an unpredictable state, causing unexpected equipment operation.

If you attempt to insert or modify a rung with MSG, PTO, and PWM instruction, the following error message will be generated by programming software "Error: Online editing of PTO, PWM and MSG are not allowed on ML1100 RUN mode." And, the rung with MSG, PTO, and PWM instruction will not be accepted.

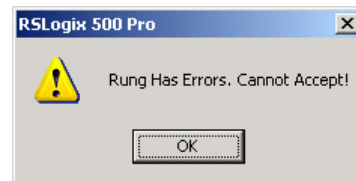

In online edit during PROGRAM mode (program online edit), there are no restrictions. For example, a user can insert MSG instruction if related MG file or MG/RI file is already defined in data file.

ATTENTION

When editing a rung that contains an MCR instruction, both the MCR start and MCR end rungs must be edited (whether it be test/assemble/cancel) at the same time. We recommend that you fully understand the possible results of the edit to the system under control. Failure to properly edit a running program could result in unexpected controller operation. Physical injury or equipment damage may result.

ATTENTION

If you use EII or STI interrupts and your application requires a quick interrupt latency, the online edit feature is not recommended. Online editing feature may increase the interrupt latency response time. To ensure minimum interrupt latency, place the mode switch in LCD screen in the RUN mode. This prevents the use of the online editing feature.

Types of Online Editing

The type of online editing is dependent on the MicroLogix 1100 processor's mode switch position in LCD display and the processor's mode. There are two types of online editing:

- Program Online Editing — when the processor is in either PROG mode or REM Program mode
- Runtime Online Editing — when the processor is in either REM Test or REM Run mode

The following table summarizes the MicroLogix 1100 processor mode switch positions in LCD and modes that enable online editing.

mode switch Position	MicroLogix 1100 Processor Mode	Editing Mode
RUN	RUN	Not Available
PROGram	Program	Program Online Editing
REMote	REMote Program	Program Online Editing
REMote	REMote Test	Program Online Editing
REMote	REMote Run	Program Online Editing

IMPORTANT Online editing is not available when the mode switch in LCD screen is in the RUN position.

ATTENTION



Use the online editing function while in the RUN mode to make minor changes to the ladder program. We recommend developing your program offline since ladder rung logic changes take effect immediately after testing your edits. Improper machine operation may occur, causing personnel injury or equipment damage.

Edit Functions in Runtime Online Editing

During a runtime online editing session, the processor *is executing* ladder logic. The edit zone markers tell the processor that changes exist, but the changes are not executed until you test the edits.

Deleted and replaced (modified) rungs are not removed from the program and inserted rungs are not executed until you assemble the edits.

Edit Functions in Program Online Editing

During a program online editing session, the processor *is not executing* ladder logic. This mode is like the offline editing mode. Note that if a runtime online editing session was performed prior to entering the offline editing mode, edit marked rungs (I, IR, and D) *appear* in the program.

If you perform a program online edit, once you accept or delete the rung, the edits take effect immediately and the power rail is displayed as a solid line. If you edit a rung with edit zone markers, the markers are removed when the rung is accepted.

Specifications

General Specifications

Description	1763-			
	L16AWA	L16BWA	L16BBB	L16DWD
Dimensions	Height: 90 mm (3.5 in.), 104 mm (4.09 in.) (with DIN latch open) Width: 110 mm (4.33 in.), Depth: 87 mm (3.43 in.)			
Shipping weight	0.9 kg (2.0 lbs)			
Number of I/O	12 inputs (10 digital and 2 analog) and 6 outputs			
Power supply voltage	100...240V AC (-15%, +10%) at 47...63 Hz		24V DC (-15%, +10%) Class 2 SELV	12V to 24V DC (-15%, +10%) Class 2 SELV
Heat dissipation	See Appendix G .			
Power supply inrush current (max.)	120V AC: 25 A for 8 ms 240V AC: 40 A for 4 ms		24V DC: 15 A for 20 ms	
Maximum power consumption	46 VA	52 VA	35 W See MicroLogix 1100 DC Input Power Requirements for 1763-L16BBB Unit on page 155 .	
24V DC sensor power	None	250 mA at 24V DC AC Ripple < 500 mV peak-to-peak 400 µF max.	None	
Input circuit type	Digital: 120V AC Analog: 0...10V DC	Digital: 24V DC sink/source (standard and high-speed) Analog: 0...10V DC	Digital: 24V DC sink/source (standard and high-speed) Analog: 0...10V DC	
Output circuit type	Relay	Relay	Relay/FET	Relay
Pilot duty rating	Ordinary location – B300, R150 Hazardous location – C300, R150			
Temperature, operating	-20...65 °C (-4...149 °F) ambient			
Temperature, storage	-40...85 °C (-40...185 °F) ambient			
Relative humidity	5%...95% non-condensing			
Vibration	Operating: 10...500 Hz, 5 g, 0.015 in. max. peak-to-peak, 2 hours each axis Relay Operation: 1.5 g			
Shock, operating	30 g; 3 pulses each direction, each axis Relay Operation: 10 g			
Shock, non-operating	50 g panel mounted (40 g DIN Rail mounted); 3 pulses each direction, each axis			
Terminal screw torque	0.56 Nm (5.0 in-lb) rated			

General Specifications

Description	1763-			
	L16AWA	L16BWA	L16BBB	L16DWD
Agency certification	UL Listed Industrial Control Equipment for use in Class 1, Division 2, Hazardous Locations, Groups A, B, C, D			
	C-UL Listed Industrial Control Equipment for use in Canada			
	CE marked for all applicable directives			
	RCM marked for all applicable acts			
	EAC certified for: Russian Customs Union TR CU 020/2011 EMC Technical Regulation, Russian Customs Union TR CU 004/2011 LV Technical Regulation			
ESD immunity	EN 61000-4-2 4 kV contact, 8 kV air, 4 kV indirect			
Radiated RF immunity	EN 61000-4-3 10V/m, 26...1000 MHz (alternatively, 80...1000 MHz), 80% amplitude modulation, +900 MHz keyed carrier			
Fast transient immunity	EN 61000-4-4 2 kV, 5 kHz communications cable such as EtherNet, RS-232, and RS-485: 1 kV, 5 kHz			
Surge transient immunity	EN 61000-4-5 Unshielded communications cable: 2 kV CM (common mode), 1 kV DM (differential mode) Shielded communications cable: 1 kV galvanic gun I/O: 2 kV CM (common mode), 1 kV DM (differential mode) AC Power Supply Input: 4 kV CM (common mode), 2 kV DM (differential mode) DC Power Supply Input: 500V CM (common mode), 500V DM (differential mode) AC/DC Auxiliary Output: 500V CM (common mode), 500V DM (differential mode)			
Conducted RF immunity	EN 61000-4-6 10V, 150 kHz...80 MHz			
Conducted emissions	EN 55011 AC Power Supply Input: 150 kHz...30 MHz			
Radiated emissions	EN 55011 30...1000 MHz			
Line related tests	EN 61000-4-11 AC Power Supply Input: voltage drop: -30% for 10 ms, -60% for 100 ms voltage interrupt: at voltage greater than -95% for 5 sec. voltage fluctuation: +10% for 15 minutes, -10% for 15 minutes DC Power Supply Input: voltage fluctuation: +20% for 15 minutes, -20% for 15 minutes			

MicroLogix 1100 DC Input Power Requirements for 1763-L16BBB Unit

1763-L16BBB and 1763-L16DWD Typical Power Requirements

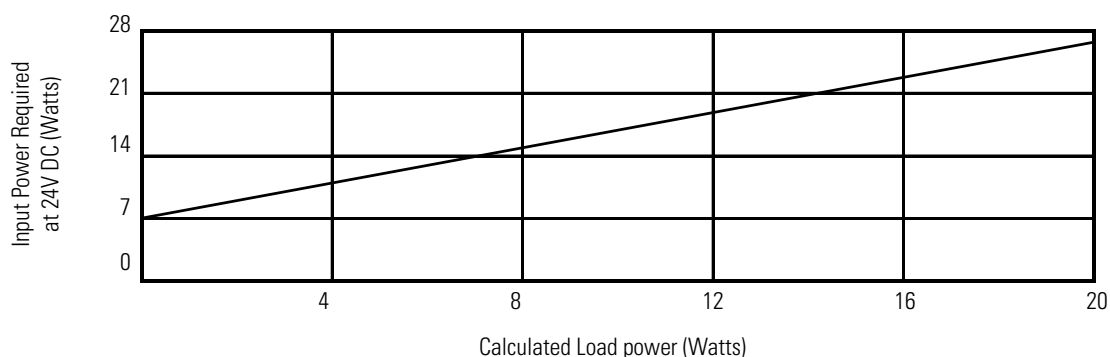

Digital Input Specifications

Description	1763-L16AWA	1763-L16BWA, -L16BBB	
		Inputs 0 through 3 (4 high-speed DC inputs)	Inputs 4 and higher (6 standard DC inputs)
On-state voltage range	79...132V AC	14...24V DC (14...26.4V DC (+10%) at 65 °C/149 °F) (14...30V DC (+25%) at 30 °C/86 °F)	10...24V DC (10...26.4V DC (+10%) at 65 °C/149 °F) (10...30V DC (+25%) at 30 °C/86 °F)
Off-State voltage range	0...20V AC	0...5V DC	
Operating frequency	47 Hz...63 Hz	0 Hz...20 kHz 0 Hz...40 kHz ⁽¹⁾	0 Hz...1 kHz (scan time dependent)
On-state current:			
<ul style="list-style-type: none"> • minimum • nominal • maximum 	<ul style="list-style-type: none"> • 5.0 mA at 79V AC • 12 mA at 120V AC • 16.0 mA at 132V AC 	<ul style="list-style-type: none"> • 2.5 mA at 14V DC • 9.8 mA at 24V DC • 12.0 mA at 30V DC 	<ul style="list-style-type: none"> • 2.0 mA at 10V DC • 8.5 mA at 24V DC • 12.0 mA at 30V DC
Off-state leakage current, max.	2.5 mA	1.5 mA	
Nominal impedance	12 k Ω at 50 Hz 10 k Ω at 60 Hz	3.1 k Ω	3.1 k Ω
Inrush current (max.) at 120V AC	250 mA	Not applicable	

(1) OS Series B FRN 4 or later

Digital Input Specifications for 1763-L16DWD

Description	1763-L16DWD	
	Inputs 0 through 3 (4 high-speed DC inputs)	Inputs 4 and higher (6 standard DC inputs)
On-state voltage range	10...24V DC at 65 °C/149 °F (10...30V DC at 30 °C/86 °F)	
Off-state voltage range	0...5V DC	
Operating frequency	0 Hz...40 kHz ⁽¹⁾	0 Hz...1 kHz
On-state current:	<ul style="list-style-type: none"> • minimum • nominal • maximum 	
	<ul style="list-style-type: none"> • 2.0 mA at 10V DC • 8.5 mA at 24V DC • 12.0 mA at 30V DC 	
Off-state leakage current	1.5 mA max.	
Nominal impedance	2.61 k Ω	3.1 k Ω
Maximum inrush current	Not applicable	

(1) OS Series B FRN 4 or later

Analog Input Specifications

Description	1763-L16AWA, -L16BWA, -L16BBB, -L16DWD
Voltage input range	0...10.0V DC - 1 LSB
Type of data	10-bit unsigned integer
Input coding (0...10.0V DC - 1 LSB)	0...+1,023
Voltage input impedance	210 k Ω
Input resolution	10 bit
Non-linearity	±1.0% of full scale
Overall accuracy -20...65 °C (-4...149 °F)	±1.0% of full scale
Voltage input overvoltage protection	10.5V DC
Field wiring to logic isolation	Non-isolated with logic

Output Specifications For Hazardous Locations Applications (Class I, Division 2, Groups A, B, C, D) - General

Description		1763-	
		-L16AWA, -L16BWA, -L16DWD	-L16BBB
Relay and FET Outputs			
Maximum controlled load		1080V A	360V A
Maximum continuous current			
Current per group common		3 A	3 A
Current per controller	at 150V max	18 A or total of per-point loads, whichever is less	
	at 240V max	18 A or total of per-point loads, whichever is less	
Relay Outputs			
Turn on time/Turn off time		10 ms (max.) ⁽¹⁾	
Relay life - Electrical (Resistive Load)		Refer to Relay Life Chart	
Relay life - Mechanical		10,000,000 cycles	
Load current		10 mA (min.)	

(1) scan time dependent

Relay Contact Ratings⁽¹⁾

Maximum Volts	Amperes		Amperes Continuous	Volt-Amperes	
	Make	Break		Make	Break
240V AC ⁽²⁾	7.5 A	0.75 A	2.5 A	1800 VA	180 VA
120V AC ⁽³⁾	15.0 A	1.5 A	2.5 A	1800 VA	180 VA
125V DC ⁽⁴⁾	0.22 A		1.0 A	28 VA	

(1) Pilot Duty Rating: (ordinary location) – B300, R150. (hazardous location) – C300, R150.

- (2) For AC voltage applications lower than 240V AC but higher than 120V AC, the maximum make and break ratings are to be obtained by dividing the volt-amperes rating by the application voltage.
- (3) For AC voltage applications lower than 120V AC, the maximum make current is to be the same as for 120V AC, and the maximum break current is to be obtained by dividing the break volt-amperes rating by the application voltage, but the currents are not to exceed the thermal continuous current.
- (4) For DC voltage applications lower than 125V DC, the make/break ampere rating for relay contacts can be determined by dividing the volt-ampere rating by the applied DC voltage but the current values are not to exceed the thermal continuous current.

ATTENTION

Do not exceed the “Current per group common” specification.



Output Specifications For Ordinary (Non-Hazardous) Locations only - General

Description		1763-	
		L16AWA, L16BWA, L16DWD	L16BBB
Relay and FET Outputs			
Maximum controlled load		1440 VA	720 VA
Maximum continuous current			
Current per group common		5 A ⁽¹⁾	5 A
Current per controller	at 150V max	30 A or total of per-point loads, whichever is less	
	at 240V max	20 A or total of per-point loads, whichever is less	
Relay Outputs			
Turn on time/Turn off time		10 ms (max.) ⁽²⁾	
Relay life - Electrical (Resistive Load)		Refer to Relay Life Chart	
Relay life - Mechanical		10,000,000 cycles	
Load current		10 mA (.)	

(1) 3.0 A above 40 °C

(2) scan time dependent.

Relay Contact Ratings⁽¹⁾

Maximum Volts	Amperes		Amperes Continuous	Volt-Amperes	
	Make	Break		Make	Break
240V AC ⁽²⁾	15.0 A	1.5 A	5.0 A ⁽³⁾	3600 VA	360 VA
120V AC ⁽⁴⁾	30.0 A	3.0 A		3600 VA	360 VA
125V DC ⁽⁵⁾	0.22 A		1.0 A	28 VA	

(1) Pilot Duty Rating: (ordinary location) – B300, R150. (hazardous location) – C300, R150.

(2) For AC voltage applications lower than 240V AC but higher than 120V AC, the maximum make and break ratings are to be obtained by dividing the volt-amperes rating by the application voltage.

(3) 3.0 A above 40 °C.

(4) For AC voltage applications lower than 120V AC, the maximum make current is to be the same as for 120V AC, and the maximum break current is to be obtained by dividing the break volt-amperes rating by the application voltage, but the currents are not to exceed the thermal continuous current.

(5) For DC voltage applications lower than 125V DC, the make/break ampere rating for relay contacts can be determined by dividing the volt-ampere rating by the applied DC voltage but the current values are not to exceed the thermal continuous current.

ATTENTION

Do not exceed the “Current per group common” specification.



Relay Life Chart

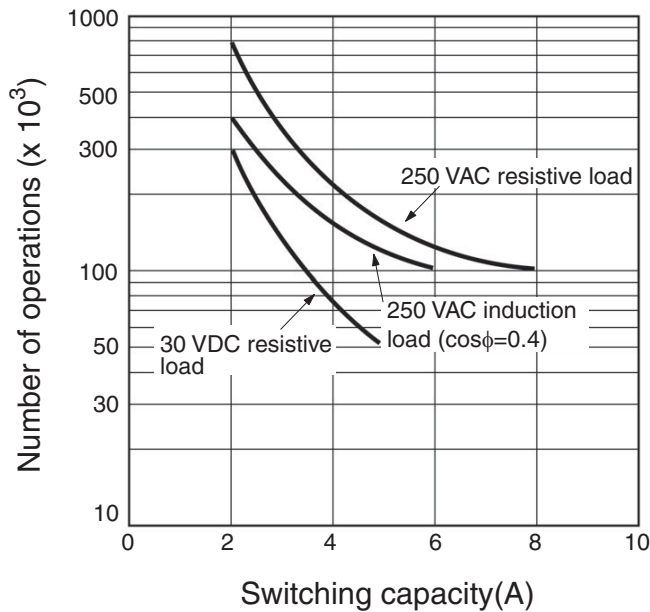

BBB FET Output Specifications

Description	General Operation	High Speed Operation ⁽¹⁾ (Output 2 and 3 Only)
Power supply voltage	24V DC (-15%, +10%)	
On-state voltage drop:		
<ul style="list-style-type: none"> •at maximum load current •at maximum surge current 	<ul style="list-style-type: none"> •1V DC •2.5V DC 	<ul style="list-style-type: none"> •Not Applicable •Not Applicable
Current rating per point		
<ul style="list-style-type: none"> •maximum load •minimum load •maximum leakage 	<ul style="list-style-type: none"> •See graphs below. •1.0 mA •1.0 mA 	<ul style="list-style-type: none"> •100 mA •10 mA •1.0 mA

Maximum output current (temperature dependent):

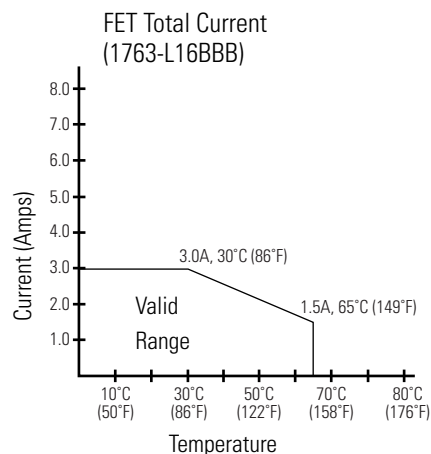
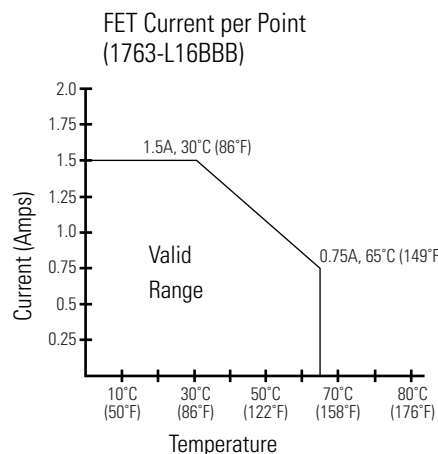

BBB FET Output Specifications

Description	General Operation	High Speed Operation ⁽¹⁾ (Output 2 and 3 Only)
Surge current per point: <ul style="list-style-type: none"> • peak current • maximum surge duration • maximum rate of repetition at 30 °C (86 °F) • maximum rate of repetition at 55 °C (131 °F) 	<ul style="list-style-type: none"> • 4.0 A • 10 ms • once every second • once every 2 seconds 	<ul style="list-style-type: none"> • Not applicable • Not applicable • Not applicable • Not applicable
Turn-on time, max.	0.1 ms	6 µs
Turn-off time, max.	1.0 ms	18 µs
Repeatability, max.	n/a	2 µs
Drift, max.	n/a	1 µs per 5 °C (9 °F)

(1) Output 2 and 3 are designed to provide increased functionality over the other FET outputs. Output 2 and 3 may be used like the other FET transistor outputs, but in addition, within a limited current range, they may be operated at a higher speed. Output 2 and 3 also provide a pulse train output (PTO) or pulse width modulation output (PWM) function.

AC Input Filter Settings

Nominal Filter Setting (ms)	ON Delay (ms)		OFF Delay (ms)	
	Minimum	Maximum	Minimum	Maximum
8	2	20	10	20

High-Speed DC Input Filter Settings (Inputs 0 to 3)

Nominal Filter Setting (ms)	ON Delay (ms)		OFF Delay (ms)		Maximum Counter Frequency (Hz) 50% Duty Cycle
	Minimum	Maximum	Minimum	Maximum	
00125	0.005	0.0125	0.003	0.0085	40.0 kHz ⁽²⁾
0.025	0.005	0.025	0.005	0.025	20.0 kHz
0.075	0.040	0.075	0.045	0.075	6.7 kHz
0.100	0.050	0.100	0.060	0.100	5.0 kHz
0.250	0.170	0.250	0.210	0.250	2.0 kHz
0.500	0.370	0.500	0.330	0.500	1.0 kHz
1.00	0.700	1.000	0.800	1.000	0.5 kHz
2.000	1.700	2.000	1.600	2.000	250 Hz
4.000	3.400	4.000	3.600	4.000	125 Hz
8.000 ⁽¹⁾	6.700	8.000	7.300	8.000	63 Hz
16.000	14.000	16.000	14.000	16.000	31 Hz

(1) This is the default setting.

(2) OS Series B FRN4 or later

Standard DC Input Filter Settings (Inputs 4 and higher)

Nominal Filter Setting (ms)	ON Delay (ms)		OFF Delay (ms)		Maximum Frequency (Hz) 50% Duty Cycle
	Minimum	Maximum	Minimum	Maximum	
0.500	0.090	0.500	0.020	0.500	1.0 kHz
1.000	0.500	1.000	0.400	1.000	0.5 kHz
2.000	1.100	2.000	1.300	2.000	250 Hz
4.000	2.800	4.000	2.700	4.000	125 Hz
8.000 ⁽¹⁾	5.800	8.000	5.300	8.000	63 Hz
16.000	11.000	16.000	10.000	16.000	31 Hz

(1) This is the default setting.

Working Voltage (1763-L16AWA)

Description	1763-L16AWA
Power supply input to backplane isolation	Verified by one of the following dielectric tests: 1836V AC for 1 s or 2596V DC for 1 s 265V AC Working Voltage (IEC Class 2 reinforced insulation)
Input group to backplane isolation	Verified by one of the following dielectric tests: 1517V AC for 1 s or 2145V DC for 1 s 132V AC Working Voltage (IEC Class 2 reinforced insulation)
Input group to input group isolation	Verified by one of the following dielectric tests: 1517V AC for 1 s or 2145V DC for 1 s 132V AC Working Voltage (basic insulation)
Output group to backplane isolation	Verified by one of the following dielectric tests: 1836V AC for 1 s or 2596V DC for 1 s 265V AC Working Voltage (IEC Class 2 reinforced insulation)
Output group to output group isolation	Verified by one of the following dielectric tests: 1836V AC for 1 s or 2596V DC for 1 s 265V AC Working Voltage (basic insulation) 150V AC Working Voltage (IEC Class 2 reinforced insulation).

Working Voltage (1763-L16BWA)

Description	1763-L16BWA
Power supply input to backplane isolation	Verified by one of the following dielectric tests: 1836V AC for 1 s or 2596V DC for 1 s 265V AC Working Voltage (IEC Class 2 reinforced insulation)
Input group to backplane isolation and input group to input group isolation	Verified by one of the following dielectric tests: 1200V AC for 1 s or 1697V DC for 1 s 75V DC Working Voltage (IEC Class 2 reinforced insulation)
Output group to backplane isolation	Verified by one of the following dielectric tests: 1836V AC for 1 s or 2596V DC for 1 s 265V AC Working Voltage (IEC Class 2 reinforced insulation).
Output group to output group isolation	Verified by one of the following dielectric tests: 1836V AC for 1 s or 2596V DC for 1 s 265V AC Working Voltage (basic insulation) 150V Working Voltage (IEC Class 2 reinforced insulation)

Working Voltage (1763-L16BBB)

Description	1762-L16BBB
Input group to backplane isolation and input group to input group isolation	Verified by one of the following dielectric tests: 1200V AC for 1 s or 1697V DC for 1 s
	75V DC Working Voltage (IEC Class 2 reinforced insulation)
FET output group to backplane isolation	Verified by one of the following dielectric tests: 1200V AC for 1 s or 1697V DC for 1 s
	75V DC Working Voltage (IEC Class 2 reinforced insulation)
Relay output group to backplane isolation	Verified by one of the following dielectric tests: 1836V AC for 1 s or 2596V DC for 1 s
	265V AC Working Voltage (IEC Class 2 reinforced insulation).
Relay output group to relay output group and FET output group isolation	Verified by one of the following dielectric tests: 1836V AC for 1 s or 2596V DC for 1 s
	265V AC Working Voltage (basic insulation) 150V Working Voltage (IEC Class 2 reinforced insulation)

Working Voltage (1763-L16DWD)

Description	1763-L16BWA
Input group to backplane isolation and input group to input group isolation	Verified by one of the following dielectric tests: 1200V AC for 1 s or 1697V DC for 1 s
	75V DC Working Voltage (IEC Class 2 reinforced insulation)
Output group to backplane isolation	Verified by one of the following dielectric tests: 1836V AC for 1 s or 2596V DC for 1 s
	265V AC Working Voltage (IEC Class 2 reinforced insulation).
Output group to output group isolation	Verified by one of the following dielectric tests: 1836V AC for 1 s or 2596V DC for 1 s
	265V AC Working Voltage (basic insulation) 150V Working Voltage (IEC Class 2 reinforced insulation)

Expansion I/O Specifications

Digital I/O Modules

General Specifications

Specification	Value
Dimensions	90 mm (height) x 87 mm (depth) x 40.4 mm (width) height including mounting tabs is 110 mm 3.54 in. (height) x 3.43 in. (depth) x 1.59 in. (width) height including mounting tabs is 4.33 in.
Temperature, storage	-40...85 °C (-40...185 °F)
Temperature, operating	-20...65 °C (-4...149 °F) ⁽¹⁾
Operating humidity	5...95% non-condensing
Operating altitude	2000 m (6561 ft)
Vibration	Operating: 10...500 Hz, 5 g, 0.030 in. max. peak-to-peak, 2 hours per axis Relay Operation: 1.5 g
Shock	Operating: 30 g panel mounted, 3 pulses per axis Relay Operation: 7 g Non-Operating: 50 g panel mounted, 3 pulses per axis (40G DIN Rail mounted)
Agency certification	C-UL certified (under CSA C22.2 No. 142) UL 508 listed CE compliant for all applicable directives C-Tick marked for all applicable acts
Hazardous environment class	For 1762-IQ32T, 1762-OB32T, and 1762-OV32T modules Hazardous Location, Class I, Division 2 Groups A, B, C, D (UL 1604, C-UL under CSA C22.2 No. 213, ANSI/ISA-12.12.01) For all other modules: Hazardous Location, Class I, Division 2 Groups A, B, C, D (UL 1604, C-UL under CSA C22.2 No. 213) for all modules
Radiated and conducted emissions	EN50081-2 Class A
Electrical/EMC:	The module has passed testing at the following levels:
ESD immunity	For 1762-IQ32T, 1762-OB32T, and 1762-OV32T modules IEC61000-4-2: 4 kV contact, 8 kV air, 4 kV indirect For all other modules: IEC1000-4-2: 4 kV contact, 8 kV air, 4 kV indirect
Radiated RF immunity	For 1762-IQ32T, 1762-OB32T, and 1762-OV32T modules IEC61000-4-3: 10V/m, 80...2700 MHz, 80% amplitude modulation For all other modules: IEC1000-4-3: 10 V/m, 80...1000 MHz, 80% amplitude modulation, +900 MHz keyed carrier for all modules

General Specifications

Specification	Value
EFT/B immunity	For 1762-IQ32T, 1762-OB32T, and 1762-OV32T modules IEC61000-4-4: 2 kV, 5 kHz on signal ports For all other modules IEC1000-4-4: 2 kV, 5 kHz
Surge transient immunity	For 1762-IQ32T, 1762-OB32T, and 1762-OV32T modules IEC61000-4-5: 2 kV common mode, 1 kV differential mode For all other modules IEC1000-4-5: 2 kV common mode, 1 kV differential mode
Conducted RF immunity	For 1762-IQ32T, 1762-OB32T, and 1762-OV32T modules IEC61000-4-6: 10V, 0.15...80 MHz ⁽²⁾ For all other modules: IEC1000-4-6: 10V, 0.15...80 MHz ⁽²⁾

(1) Refer to the module's Installation Instruction for exact operating temperature range.

(2) Conducted Immunity frequency range may be 150 kHz to 30 MHz if the Radiated Immunity frequency range is 30...1000 MHz.

Input Specifications

Specification	1762-IA8	1762-IQ8	1762-IQ16	1762-IQ32T	1762-IQ80W6
Shipping weight, approx. (with carton)	209 g (0.46 lbs.)	200 g (0.44 lbs.)	230 g (0.51 lbs.)	200g (0.44 lbs.)	280g (0.62 lbs.)
Voltage category	100/120V AC	24V DC (sink/source) ⁽¹⁾	24V DC (sink/source) ⁽¹⁾	24V DC (sink/source) ⁽¹⁾	24V DC (sink/source) ⁽¹⁾
Operating voltage range	79V AC...132V AC at 47 Hz...63 Hz	10...30V DC at 30 °C (86 °F) 10...26.4V DC at 55 °C (131 °F)	10...30V DC 10...26.4V DC ⁽³⁾⁽²⁾	10...30V DC (24 points) at 30 °C (86 °F) 10...26.4V DC (23 points) at 60 °C (140 °F)	10...30V DC at 30 °C (86 °F) 10...26.4V DC at 65 °C (149 °F)
Number of inputs	8	8	16	32	8
Bus current draw, max.	50 mA at 5V DC (0.25W)	50 mA at 5V DC (0.25W)	70 mA at 5V DC (0.35W) ⁽³⁾	170 mA at 5V DC 0 mA at 24V DC	110 mA at 5V DC 80 mA at 24V DC
Heat dissipation, max.	2.0 W	3.7 W	4.3 W at 26.4V 5.4 W at 30V ⁽³⁾	5.4 W at 26.4V DC 6.8 W at 30V DC	5.0 W at 30V DC 4.4 W at 26.4V DC (The Watts per point, plus the minimum W, with all points energized.)
Signal delay, max.	On delay: 20.0 ms Off delay: 20.0 ms	On delay: 8.0 ms Off delay: 8.0 ms	On delay: 8.0 ms Off delay: 8.0 ms	On delay: 8.0 ms Off delay: 8.0 ms	On delay: 8.0 ms Off delay: 8.0 ms
Off-state voltage, max.	20V AC	5V DC	5V DC	5V DC	5V DC
Off-state current, max.	2.5 mA	1.5 mA	1.5 mA	1.0 mA	1.5 mA

Input Specifications

Specification	1762-IA8	1762-IQ8	1762-IQ16	1762-IQ32T	1762-IQ80W6
On-state voltage, min.	79V AC (min.) 132V AC (max.)	10V DC	10V DC	10V DC	10V DC
On-state current	5.0 mA (min.) at 79V AC 47 Hz 12.0 mA (nominal) at 120V AC 60 Hz 16.0 mA (max.) at 132V AC 63 Hz	2.0 mA min. at 10V DC 8.0 mA nominal at 24V DC 12.0 mA max. at 30V DC	2.0 mA min. at 10V DC 8.0 mA nominal at 24V DC 12.0 mA max. at 30V DC	1.6 mA min. at 10V DC 2.0 mA min. at 15V DC 5.7 mA max. at 26.4V DC 6.5 mA max. at 30.0V DC	10 mA at 5V DC
Inrush current, max.	250 mA	Not applicable	Not applicable	Not applicable	250 mA
Nominal impedance	12K Ω at 50 Hz 10K Ω at 60 Hz	3K Ω	3K Ω	4.7K Ω	3K Ω
Power supply distance rating	6 (The module may not be located more than 6 modules away from the power supply.)				
IEC input compatibility	Type 1+	Type 1+	Type 1+	Type 1	Type 1+
Isolated groups	Group 1: inputs 0...7 (internally connected commons)	Group 1: inputs 0...7 (internally connected commons)	Group 1: inputs 0...7; Group 2: inputs 8...15	Group 1: Inputs 0...7; Group 2: Inputs 8...15; Group 3: Inputs 16...23; Group 4: Inputs 24...31	Group 1: inputs 0...3; Group 2: inputs 4...7
Input group to backplane isolation	Verified by one of the following dielectric tests: 1517V AC for 1 s or 2145V DC for 1 s. 132V AC working voltage (IEC Class 2 reinforced insulation)	Verified by one of the following dielectric tests: 1200V AC for 1 s or 1697V DC for 1 s 75V DC working voltage (IEC Class 2 reinforced insulation)	Verified by one of the following dielectric tests: 1200V AC for 1 s or 1697V DC for 1 s 75V DC working voltage (IEC Class 2 reinforced insulation)	Verified by one of the following dielectric tests: 1200V AC for 2 s or 1697V DC for 2 s 75V DC working voltage (IEC Class 2 reinforced insulation)	Verified by one of the following dielectric tests: 1200V AC for 1 s or 1697V DC for 1 s 75V DC working voltage (IEC Class 2 reinforced insulation)
Vendor I.D. code	1				
Product type code	7				
Product code	114	96	97	99	98

(1) Sinking/Sourcing Inputs - Sourcing/sinking describes the current flow between the I/O module and the field device. Sourcing I/O circuits supply (source) current to sinking field devices. Sinking I/O circuits are driven by a current sourcing field device. Field devices connected to the negative side (DC Common) of the field power supply are sinking field devices. Field devices connected to the positive side (+V) of the field supply are sourcing field devices.

(2) Refer to Publication [1762-IN10](#), MicroLogix 1762-IQ16 DC Input Module Installation Instructions, for the derating chart.

(3) Only applicable to Series B I/O modules.

Output Specifications

Specification	1762-OA8	1762-OB8	1762-OB16	1762-OB32T	1762-OV32T
Shipping weight, approx. (with carton)	215 g (0.48 lbs.)	210 g (0.46 lbs.)	235 g (0.52 lbs.)	200 g (0.44 lbs.)	200 g (0.44 lbs.)
Voltage category	100...240V AC	24V DC	24V DC	24V DC source	24V DC sink
Operating voltage range	85...265V AC at 47...63 Hz	20.4...26.4V DC	20.4...26.4V DC	10.2...26.4V DC	10.2...26.4V DC
Number of outputs	8	8	16	32	32
Bus current draw, max.	115 mA at 5V DC (0.575 W)	115 mA at 5V DC (0.575 W)	175 mA at 5V DC (0.88 W)	175 mA at 5V DC 0 mA at 24V DC	175 mA at 5V DC 0 mA at 24V DC
Heat dissipation, max.	2.9 W	1.61 W	2.9 W at 30 °C (86 °F) 2.1 W at 55 °C (131 °F)	3.4 W at 26.4 DC	2.7 W at 26.4V DC
Signal delay, max. – resistive load	On delay: 1/2 cycle Off delay: 1/2 cycle	On delay: 0.1 ms Off delay: 1.0ms	On delay: 0.1 ms Off delay: 1.0 ms	On delay: 0.5 ms Off delay: 4.0 ms	On delay: 0.5 ms Off delay: 4.0 ms
Off-state leakage current, max.	2 mA at 132V, 2.5 mA at 265V	1.0 mA	1.0 mA	0.1 mA at 26.4V DC	0.1 mA at 26.4V DC
On-state current, min.	10 mA	1.0 mA	1.0 mA	1.0 mA	1.0 mA
On-state voltage drop, max.	1.5V at 0.5 A	1.0V DC	1.0V DC	0.3V DC at 0.5 A	0.3V DC at 0.5A
Continuous current per point, max.	0.25 A at 55 °C (131 °F) 0.5 A at 30 °C (86 °F)	0.5 A at 55 °C (131 °F) 1.0 A at 30 °C (86 °F)	0.5 A at 55 °C (131 °F) 1.0 A at 30 °C (86 °F)	0.5 A at 60 °C (140 °F)	0.5A at 60 °C (140 °F)
Continuous current per common, max.	1.0 A at 55 °C (131 °F) 2.0 A at 30 °C (86 °F)	4.0 A at 55 °C (131 °F) 8.0 A at 30 °C (86 °F)	4.0 A at 55 °C (131 °F) 8.0 A at 30 °C (86 °F)	2.0 A at 60 °C (140 °F)	2.0 A at 60 °C (140 °F)
Continuous current per module, max.	2.0 A at 55 °C (131 °F) 4.0 A at 30 °C (86 °F)	4.0 A at 55 °C; 8.0 A at 30 °C	4.0 A at 55 °C (131 °F) 8.0 A at 30 °C (86 °F)	4.0 A at 60 °C (140 °F)	4.0 A at 60 °C (140 °F)
Surge current, max.	5.0 A (Repeatability is once every 2 s for a duration of 25 ms.)	2.0 A (Repeatability is once every 2 s at 55 °C (131 °F), once every second at 30 °C (86 °F) for a duration of 10 ms.)	2.0 A (Repeatability is once every 2 s at 55 °C (131 °F), once every second at 30 °C (86 °F) for a duration of 10 ms.)	2.0 A (Repeatability is once every 2 s at 60 °C (140 °F) for 10 ms)	2.0 A (Repeatability is once every 2 s at 60 °C (140 °F) for 10 ms)
Power supply distance rating	6 (The module may not be more than 6 modules away from the power supply.)				
Isolated groups	Group 1: Outputs 0 to 3 Group 2: Outputs 4 to 7	Group 1: Outputs 0 to 7	Group 1: Outputs 0 to 15	Group 1: Outputs 0...15 Group 2: Outputs 16...31 (internally connected to common)	

Output Specifications

Specification	1762-OA8	1762-OB8	1762-OB16	1762-OB32T	1762-OV32T
Output group to backplane isolation	Verified by one of the following dielectric tests: 1836V AC for 1 s or 2596V DC for 1 s. 265V AC working voltage (IEC Class 2 reinforced insulation)	Verified by one of the following dielectric tests: 1200V AC for 1 s or 1697V DC for 1 s. 75V DC working voltage (IEC Class 2 reinforced insulation)		Verified by one of the following dielectric tests: 1200V AC for 2 s or 1697V DC for 2 s. 75V DC working voltage (IEC Class 2 reinforced insulation)	
Output group to output group isolation	Verified by one of the following dielectric tests: 1836V AC for 1 s or 2596V DC for 1 s. 265V AC working voltage (IEC Class 2 reinforced insulation)	Not applicable		Verified by one of the following dielectric tests: 1200V AC for 2 s or 1697V DC for 2 s. 75V DC working voltage (IEC Class 2 reinforced insulation)	
Vendor I.D. code	1				
Product type code	7				
Product code	119	101	103	100	102

Output Specifications

Specification	1762-OW8	1762-OW16	1762-OX6I	1762-IO80W6
Shipping weight, approx. (with carton)	228 g (0.50 lbs.)	285 g (0.63 lbs.)	220 g (0.485 lbs)	280 g (0.62 lbs.)
Voltage category	AC/DC normally open relay	AC/DC normally open relay	AC/DC Type C Relay	AC/DC normally open relay
Operating voltage range	5...265V AC 5...125V DC	5...265V AC 5...125V DC	5...265V AC 5...125V DC	5...265V AC 5...125V DC
Number of outputs	8	16	6	6
Bus current draw, max.	80 mA at 5V DC (0.40W) 90 mA at 24V DC (2.16W)	140 mA at 5V DC (0.70W) ⁽¹⁾ 180 mA at 24V DC (4.32W) ⁽¹⁾	110 mA at 5V DC (0.55W) 110 mA at 24V DC (2.64W)	110 mA at 5V DC 80 mA at 24V DC
Heat dissipation, max.	2.9 W	6.1 W ⁽¹⁾	2.8 W	5.0 W at 30V DC 4.4 W at 26.4V DC (The Watts per point, plus the minimum W, with all points energized.)

Output Specifications

Specification	1762-OW8	1762-OW16	1762-OX6I	1762-IQ8OW6
Signal delay, max. – resistive load	On Delay: 10 ms Off Delay: 10 ms	On Delay: 10 ms Off Delay: 10 ms	On Delay: 10 ms (max) 6 ms (typical) Off Delay: 20 ms (max) 12 ms (typical)	On-delay: 10 ms (max) Off-delay: 10 ms (max)
Off-state leakage, max.	0 mA	0 mA	0 mA	0 mA
On-state current, min.	10 mA	10 mA	100 mA	10 mA
On-state voltage drop, max.	Not Applicable			
Continuous current per point, max.	2.5 A (Also see “Relay Contact Ratings” on page 169.)		7 A (Also see “Relay Contact Ratings” on page 169.)	2.5 A (Also see “Relay Contact Ratings” on page 169.)
Continuous current per common, max.	8 A	8 A	7 A (Also see “Relay Contact Ratings” on page 158.)	8 A
Continuous current per module, max.	16 A	16 A	30A (Also see Module Load Ratings 1762-OX6I on page 170.)	8A
Surge current, max.	See “Relay Contact Ratings” on page 169.		See “Relay Contact Ratings” on page 169.	See “Relay Contact Ratings” on page 169.
Power supply distance rating	6 (The module may not be more than 6 modules away from the power supply.)			
Isolated groups	Group 1: Outputs 0 to 3 Group 2: Outputs 4 to 7	Group 1: Outputs 0 to 7 Group 2: Outputs 8 to 15	All 6 Outputs Individually Isolated.	Group 3: Outputs 0 to 5
Output group to backplane isolation	Verified by one of the following dielectric tests: 1836V AC for 1 s or 2596V DC for 1 s. 265V AC working voltage (IEC Class 2 reinforced insulation)			
Output group to output group isolation	Verified by one of the following dielectric tests: 1836V AC for 1 s or 2596V DC for 1 s. 265V AC working voltage (basic insulation) 150V AC working voltage (IEC Class 2 reinforced insulation)			
Vendor I.D. code	1			
Product type code	7			
Product code	120	121	124	98

(1) Only applicable to Series B I/O modules

Relay Contact Ratings (1762-OW8, 1762-OW16, and 1762-IQ80W6)

Maximum Volts	Amperes		Amperes Continuous	Volt-Amperes	
	Make	Break		Make	Break
240V AC	7.5 A	0.75 A	2.5 A ⁽²⁾	1800 VA	180 VA
120V AC	15 A	1.5 A	2.5 A ⁽²⁾	1800 VA	180 VA
125V DC	0.22 A ⁽¹⁾		1.0 A	28 VA	
24V DC	1.2 A ⁽¹⁾		2.0 A		

(1) For DC voltage applications, the make/break ampere rating for relay contacts can be determined by dividing 28 VA by the applied DC voltage. For example, 28 VA/48V DC = 0.58A. For DC voltage applications less than 14V, the make/break ratings for relay contacts cannot exceed 2A.

(2) 1.5A above 40 °C (104 °F).

Relay Contact Ratings 1762-OX6I

Volts (max.)	Continuous Amps per Point (max.) ⁽¹⁾	Amperes ⁽³⁾		Voltamperes	
		Make	Break	Make	Break
240V AC	5.0 A	15 A	1.5 A	3600 VA	360 VA
120V AC	7.0 A ⁽²⁾	30 A	3.0 A		
125V DC	2.5 A	0.4 A		50 VA ⁽⁴⁾	
24V DC	7.0 A ⁽²⁾	7.0 A		168 VA ⁽⁴⁾	

(1) The continuous current per module must be limited so the module power does not exceed 1440VA.

(2) 6 A in ambient temperatures above 40 °C (104. °F)

(3) **Surge Suppression** – Connecting surge suppressors across your external inductive load will extend the life of the relay contacts. For additional details, refer to *Industrial Automation Wiring and Grounding Guidelines*, publication 1770-4.1.

(4) DC Make/Break Voltamperes must be limited to 50 VA for DC voltages between 28V DC and 125V DC. DC Make/Break Voltamperes below 28V DC are limited by the 7 A Make/Break current limit.

Module Load Ratings 1762-OX6I

Volts (max.)	Controlled Load (Current) per Module (max.)
240V AC	6 A
120V AC	12 A ⁽¹⁾
125V DC	11.5 A
24V DC	30 A ⁽²⁾

(1) Current per relay limited to 6 A at ambient temperatures above 40 °C (104.°F).

(2) 24 A in ambient temperatures above 40 °C (104.°F). Limited by ambient temperature and the number of relays controlling loads. See below.

Relays Used vs. Maximum Current per Relay (24V DC) 1762-OX6I

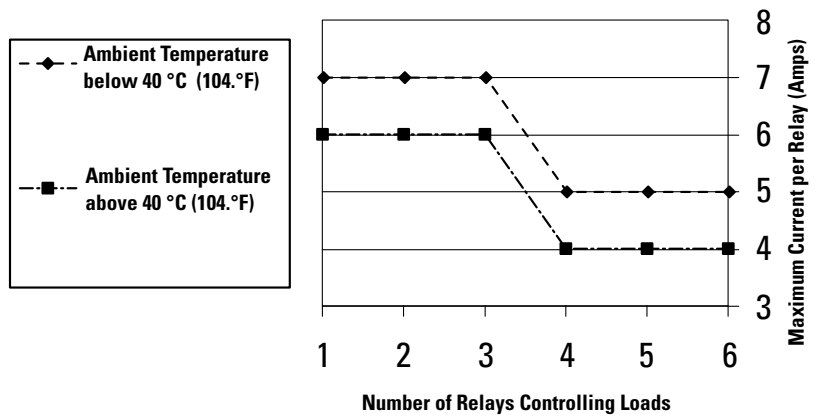

Analog Modules

Common Specifications

Specification	1762-IF2OF2, 1762-IF4, 1762-IR4, 1762-IT4 and 1762-OF4
Dimensions	90 mm (height) x 87 mm (depth) x 40 mm (width) height including mounting tabs is 110 mm 3.54 in. (height) x 3.43 in. (depth) x 1.58 in. (width) height including mounting tabs is 4.33 in.
Temperature, storage	-40 °C...85 °C (-40 °F...185 °F)
Temperature, operating	-20 °C...65 °C (-4 °F...149 °F) ⁽¹⁾
Operating humidity	5%...95% non-condensing
Operating altitude	2000 meters (6561 feet)
Vibration	Operating: 10...500 Hz, 5 g, 0.030 in. max. peak-to-peak
Shock	Operating: 30 g
Module power LED	On: indicates power is applied.
Recommended cable	Belden 8761 (shielded) (For 1762-IT4, Shielded thermocouple extension wire for the specific type of thermocouple you are using. Follow thermocouple manufacturer's recommendations.)
Agency certification	C-UL certified (under CSA C22.2 No. 142) UL 508 listed CE compliant for all applicable directives C-Tick marked for all applicable acts (1762-IR4 and 1762-IT4)
Hazardous environment class	Class I, Division 2, Hazardous Location, Groups A, B, C, D (UL 1604, C-UL under CSA C22.2 No. 213)
Noise immunity	NEMA standard ICS 2-230
Radiated and conducted emissions	EN50081-2 Class A
<i>Electrical /EMC:</i>	<i>The module has passed testing at the following levels:</i>
ESD immunity (IEC1000-4-2)	4 kV contact, 8 kV air, 4 kV indirect
Radiated immunity (IEC1000-4-3)	10 V/m, 80...1,000 MHz, 80% amplitude modulation, +900 MHz keyed carrier
Fast transient burst (IEC1000-4-4)	2 kV, 5 kHz
Surge immunity (IEC1000-4-5)	1 kV galvanic gun
Conducted immunity (IEC1000-4-6)	10V, 0.15...80 MHz ⁽²⁾ ⁽³⁾

(1) For module-specific operating temperature range, refer to the Installation Instructions for the specific module.

(2) Conducted Immunity frequency range may be 150 kHz to 30 MHz if the Radiated Immunity frequency range is 30 MHz to 1000 MHz.

(3) For grounded thermocouples, the 10V level is reduced to 3V.

General Specifications

Specification	1762-IF20F2	1762-IF4	1762-OF4	1762-IR4	1762-IT4
Shipping weight, approx. (with carton)	240 g (0.53 lbs.)		235 g (0.517 lbs.)	260 g (0.57 lbs.)	220 g (0.53 lbs.)
Bus current draw, max.	40 mA at 5V DC 105 mA at 24V DC	40 mA at 5V DC 50 mA at 24V DC	40 mA at 5V DC 165 mA at 24V DC	40 mA at 5V DC 50 mA at 24V DC	40 mA at 5V DC 50 mA at 24V DC
Analog normal operating range	Voltage: 0...10V DC Current: 4...20 mA	Voltage: -10...+10V DC Current: 4...20 mA	Voltage 0...10V DC Current: 4...20 mA	NA	NA
Full scale ⁽¹⁾ analog ranges	Voltage: 0...10.5V DC Current: 0...21 mA	Voltage: -10.5...+10.5V DC Current: -21...+21 mA	Voltage:0...10.5V DC Current: 0...21 mA	NA	NA
Resolution	12 bits (unipolar)	15 bits (bipolar) ⁽⁴⁾	12 bits (unipolar)	Input filter and configuration dependent	15 bits plus sign
Repeatability ⁽²⁾	±0.12% ⁽⁴⁾	±0.12% ⁽⁴⁾	±0.12% ⁽⁴⁾	±0.1 °C (±0.18 °F) for Ni and NiFe ±0.2 °C (±0.36 °F)...±0.2 °C (±0.36 °F) for other RTD inputs ±0.04 ohm for 150 ohm resistances ±0.2 ohm for other resistances	See Table 176
Input and output group to system isolation	30V AC/30V DC rated working voltage ⁽³⁾ (N.E.C. Class 2 required) (IEC Class 2 reinforced insulation) type test: 500V AC or 707V DC for 1 minute		30V AC/30V DC rated working voltage (IEC Class 2 reinforced insulation) type test: 500V AC or 707V DC for 1 minute	30V AC/30V DC working voltage type test: 500V AC or 707V DC for 1 minute	30V AC/30V DC working voltage qualification test: 720V DC for 1 minute
Vendor I.D. code	1	1	1	1	1
Product type code	10	10	10	10	10
Product code	75	67	66	65	64

(1) The over- or under-range flag comes on when the normal operating range (over/under) is exceeded. The module continues to convert the analog input up to the maximum full scale range.

(2) Repeatability is the ability of the module to register the same reading in successive measurements for the same signal.

(3) Rated working voltage is the maximum continuous voltage that can be applied at the terminals with respect to earth ground.

(4) Only applicable to Series B I/O modules.

Input Specifications

Specification	1762-IF20F2	1762-IF4	1762-IR4	1762-IT4
Number of inputs	2 differential (unipolar)	4 differential (bipolar)	4	4 input channels plus 1 CJC sensor
Update time (typical)	2.5 ms	130, 250, 290, 450, 530 ms (selectable)	Input filter and configuration dependent	NA
A/D converter type	Successive approximation	Successive approximation	Delta-Sigma	Delta-Sigma
Common mode voltage range ⁽¹⁾	±27V	±27V	NA	±10V
Common mode rejection ⁽²⁾	> 55 dB at 50 and 60 Hz	> 55 dB at 50 and 60 Hz	>110 dB at 50 Hz (with 10 or 50 Hz filter) >110 dB at 60 Hz (with 10 or 60 Hz filter)	>110 dB at 50 Hz (with 10 or 50 Hz filter) >110 dB at 60 Hz (with 10 or 60 Hz filter)
Non-linearity (in percent full scale)	±0.12% ⁽⁴⁾	±0.12% ⁽⁴⁾	±0.05%	NA
Typical overall accuracy ⁽³⁾	±0.55% full scale at -20...65 °C ⁽⁴⁾ ±0.3% full scale at 25 °C	±0.32% full scale at -20...65 °C ⁽⁴⁾ ±0.24% full scale at 25 °C	±0.5 °C (°F) for Pt 385	NA
Input impedance	Voltage Terminal: 200 KΩ Current Terminal: 250 Ω	Voltage Terminal: 200 KΩ Current Terminal: 275 Ω	>10 MΩ	>10 MΩ
Current input protection	±32 mA	±32 mA	NA	NA
Voltage input protection	±30V	±30V	NA	NA
Channel diagnostics	Over or under range or open circuit condition by bit reporting for analog inputs.	Over or under range or open circuit condition by bit reporting for analog inputs.	Over or under range or open circuit condition by bit reporting for analog inputs.	Over or under range or open circuit condition by bit reporting for analog inputs.

(1) For proper operation, both the plus and minus input terminals must be within ±27V (±10V for 1762-IT4) of analog common.

(2) $V_{cm} = 1 V_{pk-pk AC}$

(3) $V_{cm} = 0$ (includes offset, gain, non-linearity and repeatability error terms)

(4) Only applicable to Series B I/O models.

Input Specifications 1762-IR4

Specification	1762-IR4		
Input types	<ul style="list-style-type: none"> • 100 Ω Platinum 385 • 200 Ω Platinum 385 • 500 Ω Platinum 385 • 1,000 Ω Platinum 385 • 100 Ω Platinum 3916 • 200 Ω Platinum 3916 • 500 Ω Platinum 3916 • 1,000 Ω Platinum 3916 • 10 Ω Copper 426 • 120 Ω Nickel 672 • 120 Ω Nickel 618 • 604 Ω Nickel-Iron 518 • 0...150 Ω • 0...500 Ω • 0...1,000 Ω • 0...3,000 Ω 		
Heat dissipation	1.5 Total Watts (The Watts per point, plus the minimum Watts, with all points enabled.)		
Normal mode rejection ratio	70 dB minimum at 50 Hz with the 10 or 50 Hz filter selected 70 dB minimum at 60 Hz with the 10 or 60 Hz filter selected		
Typical accuracy [Autocalibration enabled] at 25 °C (77 °F) ambient with module operating temperature at 25 °C (77 °F) ⁽¹⁾	<table style="width: 100%; border: none;"> <tr> <td style="width: 50%; border: none;"> <ul style="list-style-type: none"> ±0.5 °C (°F) for Pt 385 ±0.4 °C (°F) for Pt 3916 ±0.2 °C (°F) for Ni ±0.3 °C (°F) for NiFe ±0.6 °C (°F) for Cu </td> <td style="width: 50%; border: none;"> <ul style="list-style-type: none"> ±0.15 Ω for 150 Ω range ±0.5 Ω for 500 Ω range ±1.0 Ω for 1,000 Ω range ±1.5 Ω for 3,000 Ω range </td> </tr> </table>	<ul style="list-style-type: none"> ±0.5 °C (°F) for Pt 385 ±0.4 °C (°F) for Pt 3916 ±0.2 °C (°F) for Ni ±0.3 °C (°F) for NiFe ±0.6 °C (°F) for Cu 	<ul style="list-style-type: none"> ±0.15 Ω for 150 Ω range ±0.5 Ω for 500 Ω range ±1.0 Ω for 1,000 Ω range ±1.5 Ω for 3,000 Ω range
<ul style="list-style-type: none"> ±0.5 °C (°F) for Pt 385 ±0.4 °C (°F) for Pt 3916 ±0.2 °C (°F) for Ni ±0.3 °C (°F) for NiFe ±0.6 °C (°F) for Cu 	<ul style="list-style-type: none"> ±0.15 Ω for 150 Ω range ±0.5 Ω for 500 Ω range ±1.0 Ω for 1,000 Ω range ±1.5 Ω for 3,000 Ω range 		
Typical accuracy [Autocalibration enabled] at 0...55 °C (32...131 °F) ⁽¹⁾	<table style="width: 100%; border: none;"> <tr> <td style="width: 50%; border: none;"> <ul style="list-style-type: none"> ±0.9 °C (°F) for Pt 385 ±0.8 °C (°F) for Pt 3916 ±0.4 °C (°F) for Ni ±0.5 °C (°F) for NiFe ±1.1 °C (°F) for Cu </td> <td style="width: 50%; border: none;"> <ul style="list-style-type: none"> ±0.25 Ω for 150 Ω range ±0.8 Ω for 500 Ω range ±1.5 Ω for 1,000 Ω range ±2.5 Ω for 3,000 Ω range </td> </tr> </table>	<ul style="list-style-type: none"> ±0.9 °C (°F) for Pt 385 ±0.8 °C (°F) for Pt 3916 ±0.4 °C (°F) for Ni ±0.5 °C (°F) for NiFe ±1.1 °C (°F) for Cu 	<ul style="list-style-type: none"> ±0.25 Ω for 150 Ω range ±0.8 Ω for 500 Ω range ±1.5 Ω for 1,000 Ω range ±2.5 Ω for 3,000 Ω range
<ul style="list-style-type: none"> ±0.9 °C (°F) for Pt 385 ±0.8 °C (°F) for Pt 3916 ±0.4 °C (°F) for Ni ±0.5 °C (°F) for NiFe ±1.1 °C (°F) for Cu 	<ul style="list-style-type: none"> ±0.25 Ω for 150 Ω range ±0.8 Ω for 500 Ω range ±1.5 Ω for 1,000 Ω range ±2.5 Ω for 3,000 Ω range 		
Accuracy drift at 0...55 °C (32...131 °F)	<table style="width: 100%; border: none;"> <tr> <td style="width: 50%; border: none;"> <ul style="list-style-type: none"> ±0.026 °C/°C (0.026 °F/°F) for Pt 385 ±0.023 °C/°C (0.023 °F/°F) for Pt 3916 ±0.012 °C/°C (0.012 °F/°F) for Ni ±0.015 °C/°C (0.015 °F/°F) for NiFe ±0.032 °C/°C (0.032 °F/°F) for Cu </td> <td style="width: 50%; border: none;"> <ul style="list-style-type: none"> ±0.007 Ω/°C (0.012 Ω/°F) for 150 Ω range ±0.023 Ω/°C (0.041 Ω/°F) for 500 Ω range ±0.043 Ω/°C (0.077 Ω/°F) for 1,000 Ω range ±0.07 2Ω/°C (0.130 Ω/°F) for 3,000 Ω range </td> </tr> </table>	<ul style="list-style-type: none"> ±0.026 °C/°C (0.026 °F/°F) for Pt 385 ±0.023 °C/°C (0.023 °F/°F) for Pt 3916 ±0.012 °C/°C (0.012 °F/°F) for Ni ±0.015 °C/°C (0.015 °F/°F) for NiFe ±0.032 °C/°C (0.032 °F/°F) for Cu 	<ul style="list-style-type: none"> ±0.007 Ω/°C (0.012 Ω/°F) for 150 Ω range ±0.023 Ω/°C (0.041 Ω/°F) for 500 Ω range ±0.043 Ω/°C (0.077 Ω/°F) for 1,000 Ω range ±0.07 2Ω/°C (0.130 Ω/°F) for 3,000 Ω range
<ul style="list-style-type: none"> ±0.026 °C/°C (0.026 °F/°F) for Pt 385 ±0.023 °C/°C (0.023 °F/°F) for Pt 3916 ±0.012 °C/°C (0.012 °F/°F) for Ni ±0.015 °C/°C (0.015 °F/°F) for NiFe ±0.032 °C/°C (0.032 °F/°F) for Cu 	<ul style="list-style-type: none"> ±0.007 Ω/°C (0.012 Ω/°F) for 150 Ω range ±0.023 Ω/°C (0.041 Ω/°F) for 500 Ω range ±0.043 Ω/°C (0.077 Ω/°F) for 1,000 Ω range ±0.07 2Ω/°C (0.130 Ω/°F) for 3,000 Ω range 		
Excitation current source	0.5 mA and 1.0 mA selectable per channel		
Open-circuit detection time ⁽²⁾	6...1212 ms		
Input channel configuration	Via configuration software screen or the user program (by writing a unique bit pattern into the module's configuration file). Refer to your controller's user manual to determine if user program configuration is supported.		
Calibration	The module performs autocalibration on channel enable and on a configuration change between channels. You can also program the module to calibrate every five minutes.		
Maximum overload at input terminals	±35V DC continuous		

Input Specifications 1762-IR4

Specification	1762-IR4
Cable impedance, max.	25 Ω (Operating with >25 Ω will reduce accuracy.)
Power supply distance rating	6 (The module may not be more than 6 modules away from the system power supply.)
Channel to channel isolation	\pm 10V DC

(1) Accuracy is dependent upon the Analog/Digital converter filter rate selection, excitation current selection, data format, and input noise.

(2) Open-circuit detection time is equal to channel update time.

Input Specifications 1762-IT4

Specification	Value
Heat dissipation	1.5 Total Watts (The Watts per point, plus the minimum Watts, with all points energized.)
Response speed per channel	Input filter and configuration dependent.
Rated working voltage ⁽¹⁾	30V AC/30V DC
Normal mode rejection ratio	85 dB (minimum) at 50 Hz (with 10 Hz or 50 Hz filter) 85 dB (minimum) at 60 Hz (with 10 Hz or 60 Hz filter)
Maximum cable impedance	25 Ω (for specified accuracy)
Open-circuit detection time	7 ms... 1.515 s ⁽²⁾
Calibration	The module performs autocalibration upon power-up and whenever a channel is enabled. You can also program the module to calibrate every five minutes.
CJC accuracy	\pm 1.3 $^{\circ}$ C (\pm 2.34 $^{\circ}$ F)
Maximum overload at input terminals	\pm 35V DC continuous ⁽³⁾
Input channel configuration	Via configuration software screen or the user program (by writing a unique bit pattern into the module's configuration file).

(1) Rated working voltage is the maximum continuous voltage that can be applied at the input terminal, including the input signal and the value that floats above ground potential (for example, 30V DC input signal and 20V DC potential above ground).

(2) Open-circuit detection time is equal to the module scan time, which is based on the number of enabled channels, the filter frequency of each channel, and whether cyclic calibration is enabled..

(3) Maximum current input is limited due to input impedance.

1762-IT4 Repeatability at 25 °C (77 °F)^{(1) (2)}

Input Type	Repeatability for 10 Hz Filter
Thermocouple J	±0.1 °C [±0.18 °F]
Thermocouple N (-110...1300 °C [-166...2372 °F])	±0.1 °C [±0.18 °F]
Thermocouple N (-210...-110 °C [-346...-166 °F])	±0.25 °C [±0.45 °F]
Thermocouple T (-170...400 °C [-274...752 °F])	±0.1 °C [±0.18 °F]
Thermocouple T (-270...-170 °C [-454...-274 °F])	±1.5 °C [±2.7 °F]
Thermocouple K (-270...1370 °C [-454...2498 °F])	±0.1 °C [±0.18 °F]
Thermocouple K (-270...-170 °C [-454...-274 °F])	±2.0 °C [±3.6 °F]
Thermocouple E (-220...1000 °C [-364...1832 °F])	±0.1 °C [±0.18 °F]
Thermocouple E (-270...-220 °C [-454...-364 °F])	±1.0 °C [±1.8 °F]
Thermocouples S and R	±0.4 °C [±0.72 °F]
Thermocouple C	±0.2 °C [±0.36 °F]
Thermocouple B	±0.7 °C [±1.26 °F]
±50 mV	±6 µV
±100 mV	±6 µV

(1) Repeatability is the ability of the input module to register the same reading in successive measurements for the same input signal.

(2) Repeatability at any other temperature in the 0...60 °C (32...140 °F) range is the same as long as the temperature is stable.

1762-IT4 Accuracy

Input Type⁽¹⁾	With Autocalibration Enabled		Without Autocalibration
	Accuracy^{(2) (3)} for 10 Hz, 50 Hz and 60 Hz Filters (max.)		Maximum Temperature Drift^{(2) (4)}
	at 25 °C [77 °F] Ambient	at 0...60 °C [32...140 °F] Ambient	at 0...60 °C [32...140 °F] Ambient
Thermocouple J (-210...1200 °C [-346...2192 °F])	±0.6 °C [±1.1 °F]	±0.9 °C [±1.7 °F]	±0.0218 °C/°C [±0.0218 °F/°F]
Thermocouple N (-200...1300 °C [-328...2372 °F])	±1 °C [±1.8 °F]	±1.5 °C [±2.7 °F]	±0.0367 °C/°C [±0.0367 °F/°F]
Thermocouple N (-210...-200 °C [-346...-328 °F])	±1.2 °C [±2.2 °F]	±1.8 °C [±3.3 °F]	±0.0424 °C/°C [±0.0424 °F/°F]
Thermocouple T (-230...400 °C [-382...752 °F])	±1 °C [±1.8 °F]	±1.5 °C [±2.7 °F]	±0.0349 °C/°C [±0.0349 °F/°F]
Thermocouple T (-270...-230 °C [-454...-382 °F])	±5.4 °C [±9.8 °F]	±7.0 °C [±12.6 °F]	±0.3500 °C/°C [±0.3500 °F/°F]
Thermocouple K (-230...1370 °C [-382...2498 °F])	±1 °C [±1.8 °F]	±1.5 °C [±2.7 °F]	±0.4995 °C/°C [±0.4995 °F/°F]
Thermocouple K (-270...-225 °C [-454...-373 °F])	±7.5 °C [±13.5 °F]	±10 °C [±18 °F]	±0.0378 °C/°C [±0.0378 °F/°F]
Thermocouple E (-210...1000 °C [-346...1832 °F])	±0.5 °C [±0.9 °F]	±0.8 °C [±1.5 °F]	±0.0199 °C/°C [±0.0199 °F/°F]

1762-IT4 Accuracy

Input Type ⁽¹⁾	With Autocalibration Enabled		Without Autocalibration
	Accuracy ⁽²⁾ ⁽³⁾ for 10 Hz, 50 Hz and 60 Hz Filters (max.)		Maximum Temperature Drift ⁽²⁾ ⁽⁴⁾
	at 25 °C [77 °F] Ambient	at 0...60 °C [32...140 °F] Ambient	at 0...60 °C [32...140 °F] Ambient
Thermocouple E (-270...-210 °C [-454...-346 °F])	±4.2 °C [±7.6 °F]	±6.3 °C [±11.4 °F]	±0.2698 °C/ °C [±0.2698 °F/ °F]
Thermocouple R	±1.7 °C [±3.1 °F]	±2.6 °C [±4.7 °F]	±0.0613 °C/ °C [±0.0613 °F/ °F]
Thermocouple S	±1.7 °C [±3.1 °F]	±2.6 °C [± 4.7 °F]	±0.0600 °C/ °C [±0.0600 °F/ °F]
Thermocouple C	±1.8 °C [±3.3 °F]	±3.5 °C [±6.3 °F]	±0.0899 °C/ °C [±0.0899 °F/ °F]
Thermocouple B	±3.0 °C [±5.4 °F]	±4.5 °C [±8.1 °F]	±0.1009 °C/ °C [±0.1009 °F/ °F]
±50 mV	±15 µV	±25 µV	±0.44µV/ °C [±0.80µV/ °F]
±100 mV	±20 µV	±30 µV	±0.69µV/ °C [±0.125µV/ °F]

(1) The module uses the National Institute of Standards and Technology (NIST) ITS-90 standard for thermocouple linearization.

(2) Accuracy and temperature drift information does not include the affects of errors or drift in the cold junction compensation circuit.

(3) Accuracy is dependent upon the analog/digital converter output rate selection, data format, and input noise.

(4) Temperature drift with autocalibration is slightly better than without autocalibration.

TIP

For more detailed 1762-IT4 accuracy information, see publication 1762-UM002.

Output Specifications

Specification	1762-IF20F2	1762-0F4
Number of outputs	2 single-ended (unipolar)	4 single-ended (unipolar) ⁽²⁾
Update time (typical)	4.5 ms	2.5 ms
D/A converter type	Resistor string	R-2R Ladder Voltage Switching
Resistive load on current output	0...500 Ω (includes wire resistance)	0...500 Ω (includes wire resistance)
Load range on voltage output	> 1KΩ	> 1KΩ
Reactive load, current output	< 0.1 mH	< 0.1 mH
Reactive load, voltage output	< 1 µF	< 1 µF
Typical overall accuracy ⁽¹⁾	±1.17% full scale at -20...65 °C ⁽²⁾ ±0.5% full scale at 25 °C	±1.17% full scale at -20...65 °C ⁽²⁾ ±0.5% full scale at 25 °C
Output ripple range 0...500 Hz (referred to output range)	< ±0.1%	< ±0.1%

Output Specifications

Specification	1762-IF20F2	1762-OF4
Non-linearity (in percent full scale)	< $\pm 0.59\%$ ⁽²⁾	< $\pm 0.59\%$ ⁽²⁾
Open and short-circuit protection	Continuous	Continuous
Output protection	± 32 mA	± 32 mA

(1) Includes offset, gain, non-linearity and repeatability error terms.

(2) Only applicable to Series B I/O modules.

Valid Input/Output Data Word Formats/Ranges for 1762-IF20F2

Normal Operating Range	Full Scale Range	RAW/Proportional Data	Scaled-for-PID
0...10V DC	10.5V DC	32,760	16,380
	0.0V DC	0	0
4...20 mA	21.0 mA	32,760	16,380
	20.0 mA	31,200	15,600
	4.0 mA	6240	3120
	0.0 mA	0	0

Replacement Parts

This chapter contains the following information:

- a table of MicroLogix 1100 replacement parts
- procedure for replacing the lithium battery

MicroLogix 1100 Replacement Kits

The table below provides a list of replacement parts and their catalog number.

Description	Catalog Number
Lithium Battery (See page 180.)	1763-BA

Lithium Battery (1763-BA)

IMPORTANT

When the controller's Battery Low indicator is lit, check whether the battery wire connector is connected correctly or replace the replaceable battery with a new one immediately. When the indicator turns on, it means that either the battery is disconnected, or that the battery requires replacement. The controller is designed to operate for up to 2 weeks, from the time that the indicator first turns on. We recommend that you replace the battery immediately when the indicator turns on.

Installation

Follow the procedure below to ensure proper replaceable battery installation.

1. Insert a battery into the battery pocket with wires facing up.
2. Insert the battery wire connector into the battery connector.
3. Secure the battery connector wires along the wire guide, as shown below.

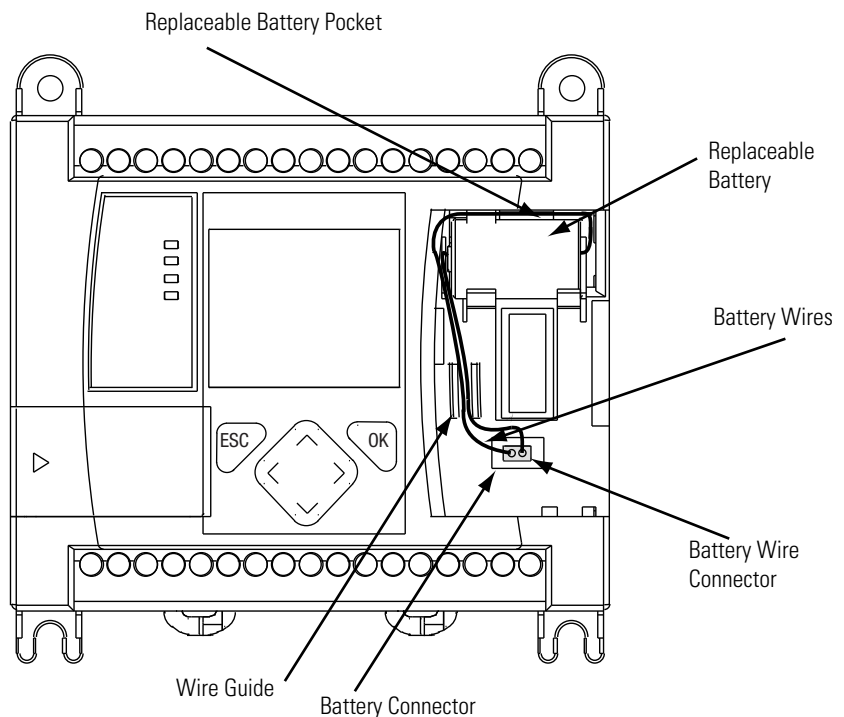

Battery Handling

Follow the procedure below to ensure proper battery operation and reduce personnel hazards.

- Use only for the intended operation.
- Do not ship or dispose of cells except according to recommended procedures.
- Do not ship on passenger aircraft.

ATTENTION

- Do not charge the batteries. An explosion could result or the cells could overheat causing burns.
 - Do not open, puncture, crush, or otherwise mutilate the batteries. A possibility of an explosion exists and/or toxic, corrosive, and flammable liquids would be exposed.
 - Do not incinerate or expose the batteries to high temperatures. Do not attempt to solder batteries. An explosion could result.
 - Do not short positive and negative terminals together. Excessive heat can build up and cause severe burns.
-

Storage

Store lithium batteries in a cool, dry environment, typically 20 °C...2 5°C (68°F...77°F) and 40%...60% humidity. Store the batteries and a copy of the battery instruction sheet in the original container, away from flammable materials.

Transportation

One or Two Batteries

Each battery contains 0.23 g of lithium. Therefore, up to two batteries can be shipped together within the United States without restriction. Regulations governing shipment to or within other countries may differ.

Three or More Batteries

Procedures for the transportation of three or more batteries shipped together within the United States are specified by the Department of Transportation (DOT) in the Code of Federal Regulations, CFR49, “Transportation.” An exemption to these regulations, DOT - E7052, covers the transport of certain hazardous materials classified as flammable solids. This exemption authorizes transport of lithium batteries by motor vehicle, rail freight, cargo vessel, and cargo-only aircraft, providing certain conditions are met. Transport by passenger aircraft is not permitted.

A special provision of DOT-E7052 (11th Rev., October 21, 1982, par. 8-a) provides that:

“Persons that receive cell and batteries covered by this exemption may reship them pursuant to the provisions of 49 CFR 173.22a in any of these packages authorized in this exemption including those in which they were received.”

The Code of Federal Regulations, 49 CFR 173.22a, relates to the use of packaging authorized under exemptions. In part, it requires that you must maintain a copy of the exemption at each facility where the packaging is being used in connection with shipment under the exemption.

Shipment of depleted batteries for disposal may be subject to specific regulation of the countries involved or to regulations endorsed by those countries, such as the IATA Articles Regulations of the International Air Transport Association, Geneva, Switzerland.

IMPORTANT

Regulations for transportation of lithium batteries are periodically revised. Refer to <http://www.dot.gov> for the latest shipping information.

Disposal

ATTENTION

Do not incinerate or dispose of lithium batteries in general trash collection. Explosion or violent rupture is possible. Batteries should be collected for disposal in a manner to prevent against short-circuiting, compacting, or destruction of case integrity and hermetic seal.

For disposal, batteries must be packaged and shipped in accordance with transportation regulations, to a proper disposal site. The U.S. Department of Transportation authorizes shipment of “Lithium batteries for disposal” by motor vehicle only in regulation 173.1015 of CFR 49 (effective January 5, 1983). For additional information contact:

U.S. Department of Transportation
Research and Special Programs Administration
400 Seventh Street, S.W.
Washington, D.C. 20590

Although the Environmental Protection Agency at this time has no regulations specific to lithium batteries, the material contained may be considered toxic, reactive, or corrosive. The person disposing of the material is responsible for any hazard created in doing so. State and local regulations may exist regarding the disposal of these materials.

For a lithium battery product safety data sheet, contact the manufacturer:

Sanyo Energy Corporation
2001 Sanyo Avenue
San Diego, CA 92173
(619) 661-4801

Tadarand U.S. Battery Division
2 Seaview Blvd.
Port Washington, NY 11050
(516) 621-4980

Notes:

Troubleshooting Your System

This chapter describes how to troubleshoot your controller. Topics include:

- understanding the controller status indicators
- controller error recovery model
- analog expansion I/O diagnostics and troubleshooting
- calling Rockwell Automation for assistance

Understanding the Controller Indicator Status

The MicroLogix 1100 provides three groups of status indicators:

- the status LEDs on the top of the controller,
- the status indicators on the LCD
- the I/O status indicators on the LCD.

Together they provide a mechanism to determine the current status of the controller if a programming device is not present or available.

Controller Status LED Indicators

Controller LED Location

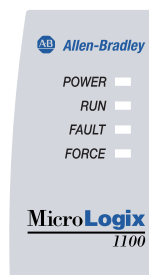

Controller LED Indicators

LED	Color	Indicates
POWER	off	No input power, or power error condition
	green	Power on
RUN	off	Not executing the user program
	green	Executing the user program in run mode
	green flashing	Memory module transfer occurring

Controller LED Indicators

LED	Color	Indicates
FAULT	off	No fault detected
	red flashing	Application fault detected
	red	Controller hardware faulted
FORCE	off	No forces installed
	amber	Forces installed
	amber flashing	Forces installed in force files, but forcing is disabled.

Status Indicators on the LCD

Status Indicators on the LCD

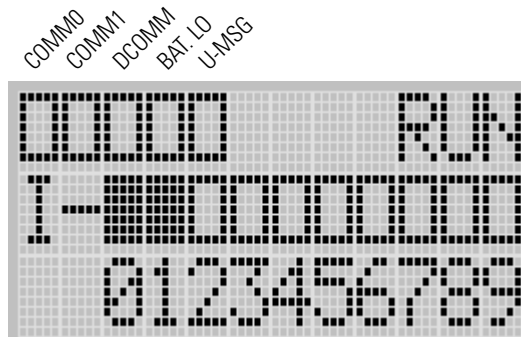

Status Indicators on the LCD

Indicator	Color	Indicates
COMM 0	off (empty rectangle)	Not transmitting via RS-232/485 port (Channel 0)
	on (solid rectangle)	Transmitting via RS-232/485 port (Channel 0)
COMM 1	off (empty rectangle)	Not transmitting via Ethernet port (Channel 1)
	on (solid rectangle)	Transmitting via Ethernet port (Channel 1)
DCOMM ⁽¹⁾	off (empty rectangle)	Configured communications
	on (solid rectangle)	Default communications

Status Indicators on the LCD

Indicator	Color	Indicates
BAT. LO	off (empty rectangle)	Battery level is acceptable
	on (solid rectangle)	Battery low
U-MSG	off (empty rectangle)	Default display mode
	on (solid rectangle)	Customized display mode

⁽¹⁾ When using a MicroLogix 1100 controller, the DCOMM LED applies only to Channel 0.

I/O Status Indicators on the LCD

I/O Status Indicators on the LCD

I/O LED screen on the LCD

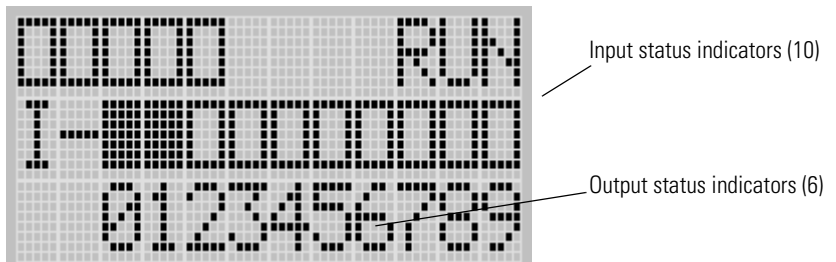

I/O Status Indicators on the LCD

Indicator	Color	Indicates
INPUTS ⁽¹⁾	off (empty rectangle)	Input is not energized
	on (solid rectangle)	Input is energized (terminal status)
OUTPUTS	off (empty rectangle)	Output is not energized
	on (solid rectangle)	Output is energized (logic status)

⁽¹⁾ To view the status of inputs and outputs on the LCD, you need to enter the I/O LED mode screen using the LCD menu. See I/O Status on page 5-107 for more information.

Normal Operation

Under normal operating conditions, the POWER and RUN LEDs are ON. If forcing is enabled and forces are installed in the I/O force files, the FORCE LED turns ON and continues to be ON until all forces are removed. If forcing is disabled and forces are installed in the I/O force files, the FORCE LED flashes and continues to flash until all forces are removed from the I/O force files.

Error Conditions

If an error exists within the controller, the controller LEDs operate as described in the following table.

If the LEDs indicate:	The Following Error Exists	Probable Cause	Recommended Action
All LEDs off	No input power or power supply error	No line Power	Verify proper line voltage and connections to the controller.
		Power Supply Overloaded	This problem can occur intermittently if power supply is overloaded when output loading and temperature varies.
Power and FAULT LEDs on solid	Hardware faulted	Processor Hardware Error	Cycle power. Contact your local Allen-Bradley representative if the error persists.
		Loose Wiring	Verify connections to the controller.
Power LED on and FAULT LED flashing	Application fault	Hardware/Software Major Fault Detected	For error codes and Status File information, see <i>MicroLogix 1100 Programmable Controllers Instruction Set Reference Manual</i> , Publication 1763-RM001.
RUN FORCE FAULT LEDs all flashing	Operating system fault	Missing or Corrupt Operating System	See Missing/Corrupt OS LED Pattern on page D-201.

Controller Error Recovery Model

Use the following error recovery model to help you diagnose software and hardware problems in the micro controller. The model provides common questions you might ask to help troubleshoot your system. Refer to the recommended pages within the model for further help.

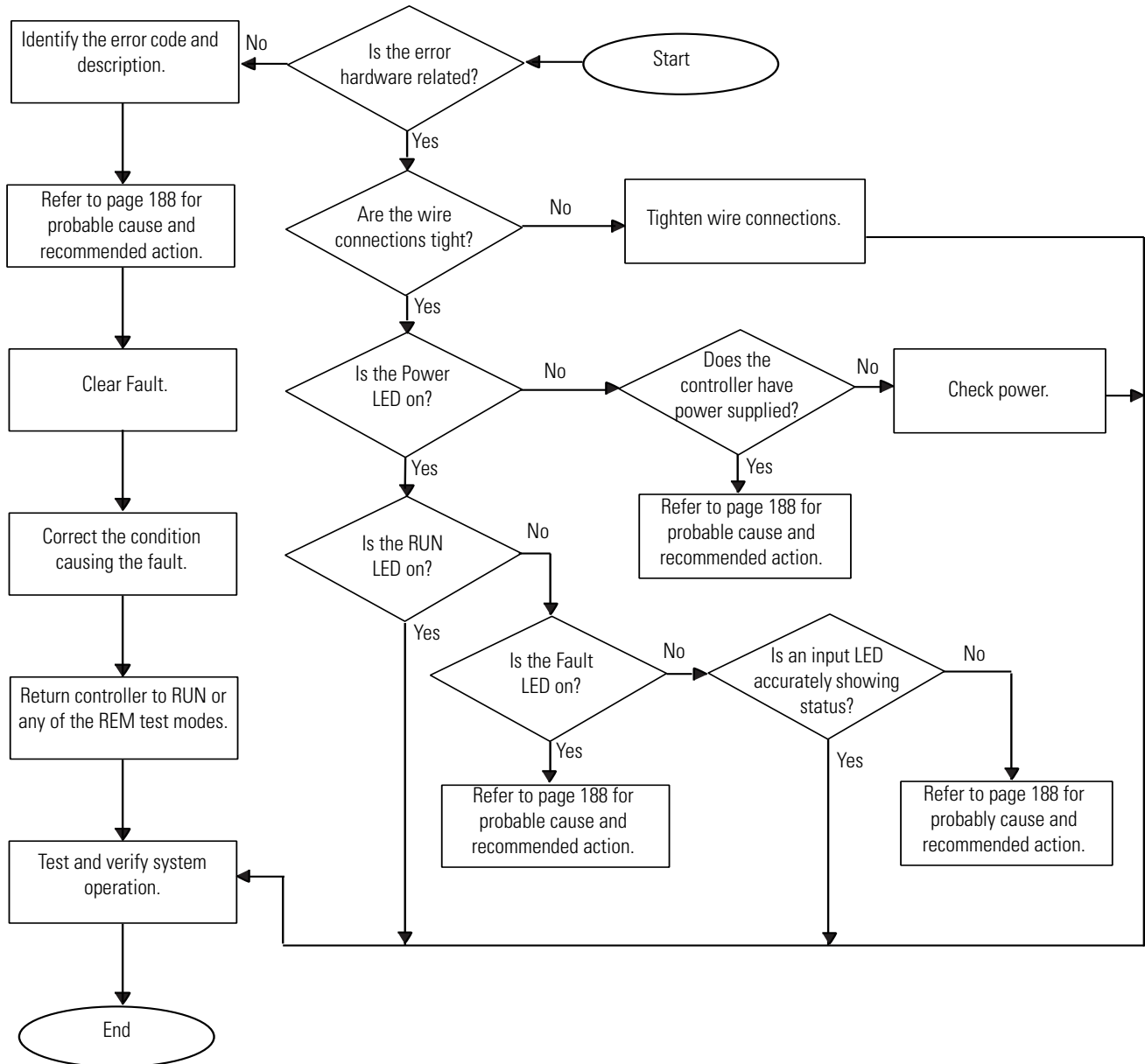

Analog Expansion I/O Diagnostics and Troubleshooting

Module Operation and Channel Operation

The module performs operations at two levels:

- module level
- channel level

Module-level operations include functions such as power-up, configuration, and communication with the controller.

Internal diagnostics are performed at both levels of operation. Both module hardware and channel configuration error conditions are reported to the controller. Channel over-range or under-range conditions are reported in the module's input data table. Module hardware errors are reported in the controller's I/O status file. Refer to the MicroLogix 1100 Programmable Controllers Instruction Set Reference Manual, publication 1763-RM001 for more information.

When a fault condition is detected, the analog outputs are reset to zero.

Power-up Diagnostics

At module power-up, a series of internal diagnostic tests are performed.

Module Status LED State Table

If module status LED is	Indicated condition	Corrective action
On	Proper Operation	No action required.
Off	Module Fault	Cycle power. If condition persists, replace the module. Call your local distributor or Allen-Bradley for assistance.

Critical and Non-Critical Errors

Non-critical module errors are recoverable. Channel errors (over-range or under-range errors) are non-critical. Non-critical error conditions are indicated in the module input data table. Non-critical configuration errors are indicated by the extended error code. See Table on page C-193.

Critical module errors are conditions that prevent normal or recoverable operation of the system. When these types of errors occur, the system leaves the run mode of operation. Critical module errors are indicated in Table on page C-193.

Module Error Definition Table

Analog module errors are expressed in two fields as four-digit Hex format with the most significant digit as “don’t care” and irrelevant. The two fields are “Module Error” and “Extended Error Information”. The structure of the module error data is shown below.

Module Error Table

“Don’t Care” Bits				Module Error			Extended Error Information								
15	14	13	12	11	10	9	8	7	6	5	4	3	2	1	0
0	0	0	0	0	0	0	0	0	0	0	0	0	0	0	0
Hex Digit 4				Hex Digit 3			Hex Digit 2				Hex Digit 1				

Module Error Field

The purpose of the module error field is to classify module errors into three distinct groups, as described in the table below. The type of error determines what kind of information exists in the extended error information field. These types of module errors are typically reported in the controller's I/O status file. Refer to the *MicroLogix 1100 Programmable Controllers Instruction Set Reference Manual*, publication 1763-RM001 for more information.

Module Error Types

Error Type	Module Error Field Value Bits 11 through 09 (Binary)	Description
No Errors	000	No error is present. The extended error field holds no additional information.
Hardware Errors	001	General and specific hardware error codes are specified in the extended error information field.
Configuration Errors	010	Module-specific error codes are indicated in the extended error field. These error codes correspond to options that you can change directly. For example, the input range or input filter selection.

Extended Error Information Field

Check the extended error information field when a non-zero value is present in the module error field. See Table on page C-193.

TIP

If no errors are present in the module error field, the extended error information field is set to zero.

Hardware Errors

General or module-specific hardware errors are indicated by module error code 2. See .

Configuration Errors

If you set the fields in the configuration file to invalid or unsupported values, the module ignores the invalid configuration, generates a non-critical error, and keeps operating with the previous configuration.

The table below lists the configuration error codes defined for the module.

Error Codes

Extended Error Codes for 1762-IF20F2

Error Type	Hex Equivalent ⁽¹⁾	Module Error Code	Extended Error Information Code	Error Description
		Binary	Binary	
No Error	X000	000	0 0000 0000	No error
General Common Hardware Error	X200	001	0 0000 0000	General hardware error; no additional information
	X201	001	0 0000 0001	Power-up reset state
Hardware-Specific Error	X210	001	0 0001 0000	Reserved
Configuration Error	X400	010	0 0000 0000	General configuration error; no additional information
	X401	010	0 0000 0001	Invalid input data format selected (channel 0)
	X402	010	0 0000 0010	Invalid input data format selected (channel 1)
	X403	010	0 0000 0011	Invalid output data format selected (channel 0)
	X404	010	0 0000 0100	Invalid output data format selected (channel 1)

⁽¹⁾ X represents "Don't Care".

Extended Error Codes for 1762-IF4 and 1762-OF4

Error Type	Hex Equivalent ⁽¹⁾	Module Error Code	Extended Error Information Code	Error Description
		Binary	Binary	
No Error	X000	000	0 0000 0000	No error
General Common Hardware Error	X200	001	0 0000 0000	General hardware error; no additional information
	X201	001	0 0000 0001	Power-up reset state
Hardware-Specific Error	X300	001	1 0000 0000	Reserved
Configuration Error	X400	010	0 0000 0000	General configuration error; no additional information
	X401	010	0 0000 0001	Invalid range select (Channel 0)
	X402	010	0 0000 0010	Invalid range select (Channel 1)
	X403	010	0 0000 0011	Invalid range select (Channel 2)
	X404	010	0 0000 0100	Invalid range select (Channel 3)
	X405	010	0 0000 0101	Invalid filter select (Channel 0) – 1762-IF4 only
	X406	010	0 0000 0110	Invalid filter select (Channel 1) – 1762-IF4 only
	X407	010	0 0000 0111	Invalid filter select (Channel 2) – 1762-IF4 only
	X408	010	0 0000 1000	Invalid filter select (Channel 3) – 1762-IF4 only
	X409	010	0 0000 1001	Invalid format select (Channel 0)
	X40A	010	0 0000 1010	Invalid format select (Channel 1)
	X40B	010	0 0000 1011	Invalid format select (Channel 2)
	X40C	010	0 0000 1100	Invalid format select (Channel 3)

⁽¹⁾ X represents "Don't Care".

Calling Rockwell Automation for Assistance

If you need to contact Rockwell Automation or local distributor for assistance, it is helpful to obtain the following (prior to calling):

- controller type, series letter, revision letter, and firmware (FRN) number of the controller
- controller indicator status
- controller error codes (Refer to MicroLogix 1100 Programmable Controllers Instruction Set Reference Manual, Publication 1763-RM001 for error code information.)

Using ControlFLASH to Upgrade Your Operating System

The operating system (OS) can be upgraded through the communication port on the controller. In order to download a new operating system, you must have the ControlFLASH Upgrade Kit which is described in the ControlFLASH Firmware Upgrade Kit User Manual, publication [1756-UM105](#).

The newer OS firmware for the controller is prepared in DMK disk image format which requires ControlFLASH version 13.00 or higher.

To upgrade the firmware for a MicroLogix controller, go to the MicroLogix product web page at <http://www.rockwellautomation.com/global/support/firmware/overview.page>.

Preparing for Firmware Upgrade

Before upgrading the controller's operating system (OS), you must:

- install ControlFLASH software on your personal computer.
- extract the DMK kit containing the latest firmware (for ControlFLASH version 13.00 or higher only).
- prepare the controller for updating.

IMPORTANT

Installing a new operating system deletes the user program on the controller. After the operating system upgrade is successful, you must transfer your control program back to the controller. The communication parameters are described on [Table on page 4-72](#).

Install ControlFLASH Software

If you have already downloaded and installed a firmware, a version of ControlFLASH may already be on your machine. If the next firmware you download has a newer version of ControlFLASH attached, then the newer

version is installed. In all cases, any previously installed firmware remains accessible.

IMPORTANT

If the next firmware you download has an older version of ControlFLASH attached, the newer version of ControlFLASH may be overwritten. For details, refer to Rockwell Knowledgebase Answer ID 41194.

Follow the steps below to install ControlFLASH with a firmware.

1. Extract the file and double-click ControlFLASH.msi. In the Welcome dialog box, review the firmware information and click the Next button.



2. In the License Agreement dialog box, after reading the license, select I Agree and click the Next button.



3. In the Select Installation Folder dialog box, if needed, browse and select another folder. Click the Next button.
4. In the Confirm Installation dialog box, click the Next button.

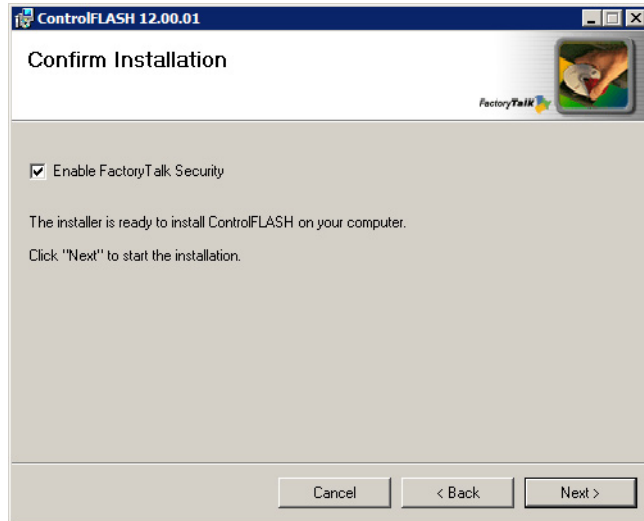

5. Follow the instructions to finish the installation.

TIP

When the installation completes, FactoryTalk Security is enabled by default. When launched, ControlFLASH logs on to the FactoryTalk Network Directory.

Use DMK Extraction Tool for Firmware Upgrade

This section applies only to the newer OS firmware prepared in DMK format which requires ControlFLASH version 13.00 or higher.

1. Launch the DMK Extraction Tool application under Programs>Flash>Programming Tools.

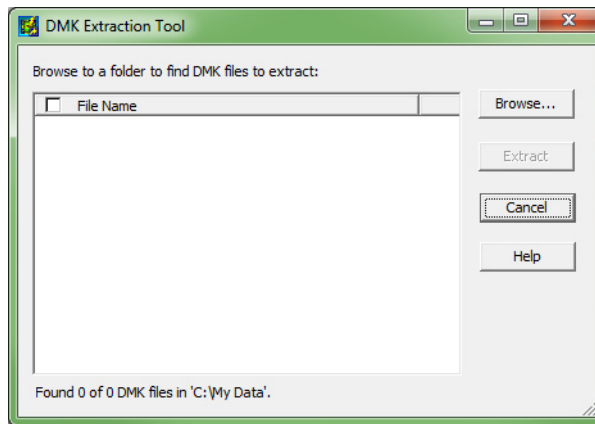

2. Click the Browse button and choose the location of the DMK file in the system.

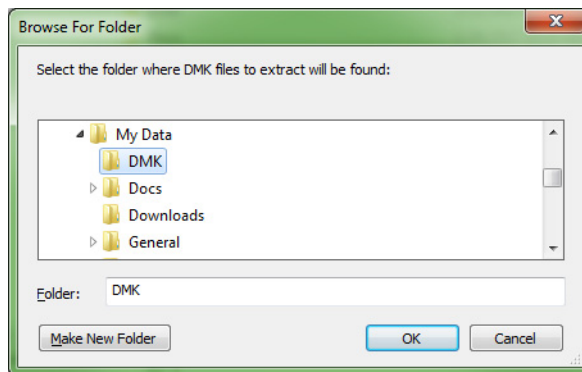

3. Click the OK button.

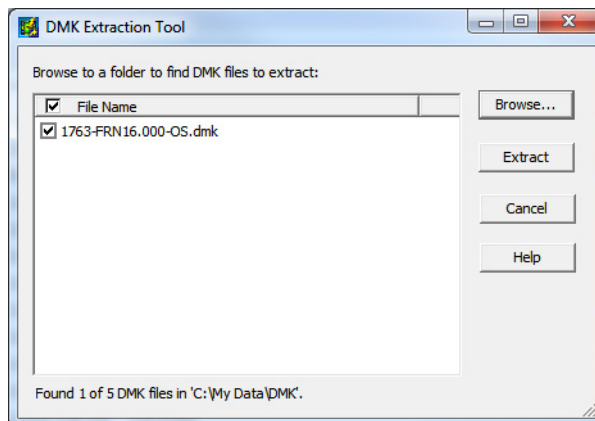

4. Select one or more DMK files that you want to extract, then click the Extract button.

The DMK Extraction Progress dialog box appears.

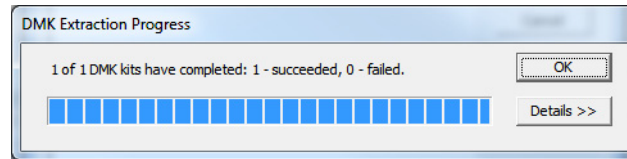

5. After the extraction is complete, click the OK button to close the dialog box.
6. Click the Cancel button to close the DMK Extraction Tool.

Once the DMK files have been extracted from a folder, they are no longer shown when the DMK Extraction Tool is used again to browse the same folder.

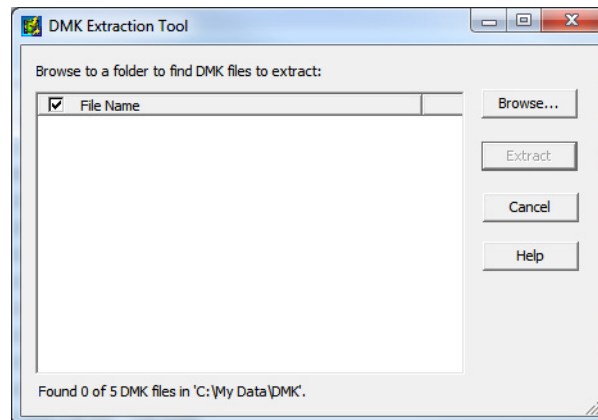

Prepare the Controller for Updating

Connect the computer COM port to channel 0 on the MicroLogix 1100 using a 1761-CBL-PM02 cable.

Controller Configuration

The controller must be configured for default communications (use the Communications Toggle Functionality which is available on the LCD; DCOMM indicator on) and be in the Program mode (use the Mode Switch which is available on the LCD.) to allow the download of a new operating system.

See [Using the Communications Toggle Functionality on page 4-72](#) for information about how to use the Communications Toggle Functionality.

See [Using the Mode Switch](#) on page 5-122 for information about controller modes and how to use the Mode Switch.

Sequence of Operation

The following steps detail the key events in the upgrade process.

1. Controller mode and communications parameters are checked. The screen as shown below is displayed on the LCD as well.

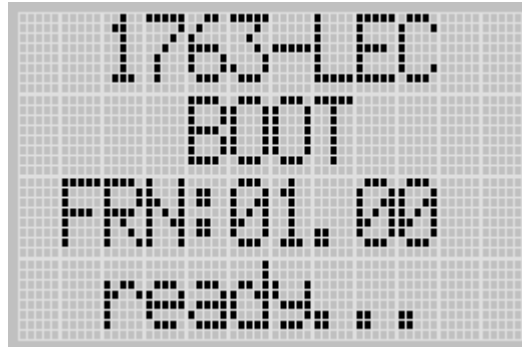

2. Download begins.
3. During the download, the Run, Force, and Fault LEDs perform a walking bit pattern. The screen as shown below is displayed on the LCD as well.

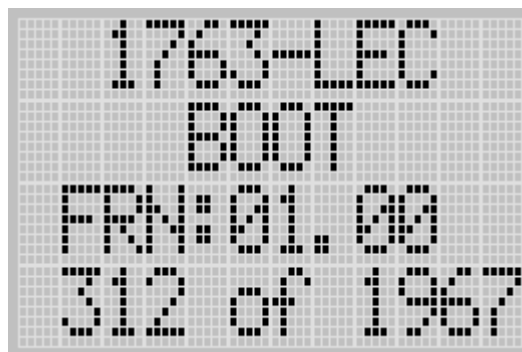

4. When the download is complete, the integrity of the new OS is checked. If the new OS is corrupt, the controller sends an error message to the download tool and flashes the Missing or Corrupt OS LED pattern. See [Missing/Corrupt OS LED Pattern](#) below.
5. Following a successful transfer, the Run, Force, and Fault LEDs flash on and remain on for five seconds. Then the controller resets.

Missing/Corrupt OS LED Pattern

When an operating system download is not successful or if the controller does not contain a valid operating system, the controller flashes the Run, Force, and Fault LEDs on and off.

Notes:

Connecting to Networks via RS-232/RS-485 Interface

The following protocols are supported from the RS-232/485 communication channel (Channel 0):

- DF1 Full Duplex
- DF1 half-duplex Master/Slave
- DF1 Radio Modem
- DH-485
- Modbus RTU Master/Slave
- ASCII

RS-232 Communication Interface

The communications port on the MicroLogix 1100 utilizes a combined RS-232/485 interface. RS-232 and RS-485 are Electronics Industries Association (EIA) standards that specify the electrical and mechanical characteristics for serial binary communication. They provide a variety of system configuration possibilities. (RS-232 and RS-485 define electrical connection characteristics, *not* protocols.)

One of the biggest benefits of an RS-232 interface is that it lets you integrate telephone and radio modems into your control system (using the appropriate DF1 protocol only, not DH-485 protocol), but it is for point-to-point connections only between two devices.

RS-485 Communication Interface

The RS-485 interface supports connection of up to 32 devices in a multidrop hard-wired configuration using DH-485, DF1-Half Duplex⁽¹⁾, or Modbus protocols. Also, the RS-485 interface supports connection in a multidrop hard-wired configuration using ASCII protocols⁽¹⁾.

DF1 Full-Duplex Protocol

DF1 Full-Duplex protocol provides a point-to-point connection between two devices. DF1 Full-Duplex protocol combines data transparency (American National Standards Institute ANSI - X3.28-1976 specification subcategory D1) and 2-way simultaneous transmission with embedded responses (subcategory F1).

⁽¹⁾ OS Series B FRN 4 or later.

The MicroLogix™ controller supports the DF1 Full-Duplex protocol via RS-232 connection to external devices, such as computers, or other controllers that support DF1 Full-Duplex.

DF1 is an open protocol. Refer to DF1 Protocol and Command Set Reference Manual, publication 1770-6.5.16, for more information.

DF1 Full-Duplex protocol (also referred to as DF1 point-to-point protocol) is useful where RS-232 point-to-point communication is required. DF1 protocol controls message flow, detects and signals errors, and retries if errors are detected.

Example DF1 Full-Duplex Connections

For information about required network connecting equipment, see [Chapter 4, Communication Connections](#).

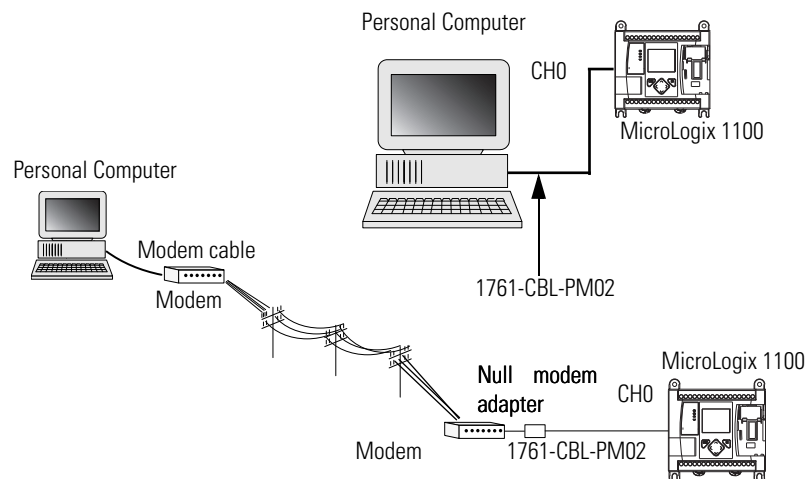

DF1 Half-Duplex Protocol

DF1 Half-Duplex protocol is a multi-drop single master/multiple slave network. DF1 Half-Duplex protocol supports data transparency (American National Standards Institute ANSI - X3.28-1976 specification subcategory D1). In contrast to DF1 Full-Duplex, communication takes place in one direction at a time. You can use the RS-232/485 port on the MicroLogix™ as both a Half-Duplex programming port and a Half-Duplex peer-to-peer messaging port.

DF1 Half-Duplex Operation

A DF1 Half-Duplex master device initiates all communication by “polling” each slave device. The slave device may only transmit when it is polled by the master. It is the master’s responsibility to poll each slave on a regular and sequential basis to allow slave devices an opportunity to communicate.

An additional feature of the DF1 Half-Duplex protocol is that it is possible for a slave device to enable a MSG write or read to/from another slave. When the initiating slave is polled, the MSG is sent to the master. The master recognizes that the message is not intended for it, but for another slave, so the master immediately forwards the message to the intended slave. The master does this automatically; you do not need to program the master to move data between slave nodes. This slave-to-slave transfer can also be used by programming software to allow slave-to-slave upload and download of programs to processors (including the master) on the DF1 Half-Duplex link.

MicroLogix 1100 can act as the master or as a slave on a Half-Duplex network. When the MicroLogix 1100 is a slave device, a master device is required to “run” the network. Several other Allen-Bradley products support DF1 Half-Duplex master protocol. They include the SLC 5/03™ and higher processors, enhanced PLC-5 processors, MicroLogix 1200/1500 and Rockwell Software RSLinx (version 2.x and higher).

DF1 Half-Duplex supports up to 255 devices (address 0 to 254) with address 255 reserved for master broadcasts. As a DF1 Half-Duplex slave device, the MicroLogix™ supports broadcast reception. As a DF1 Half-Duplex master, the MicroLogix 1100 supports both the reception and initiation of broadcast write commands (via the MSG instruction). The MicroLogix™ also supports Half-Duplex modems using RTS/CTS hardware handshaking.

Example DF1 Half-Duplex Connections

Rockwell Software RSLinx 2.0 (or later), SLC 5/03, SLC 5/04, and SLC 5/05, PLC-5, MicroLogix 1100, or MicroLogix 1200 and 1500 processors configured for DF1 Half-Duplex Master.

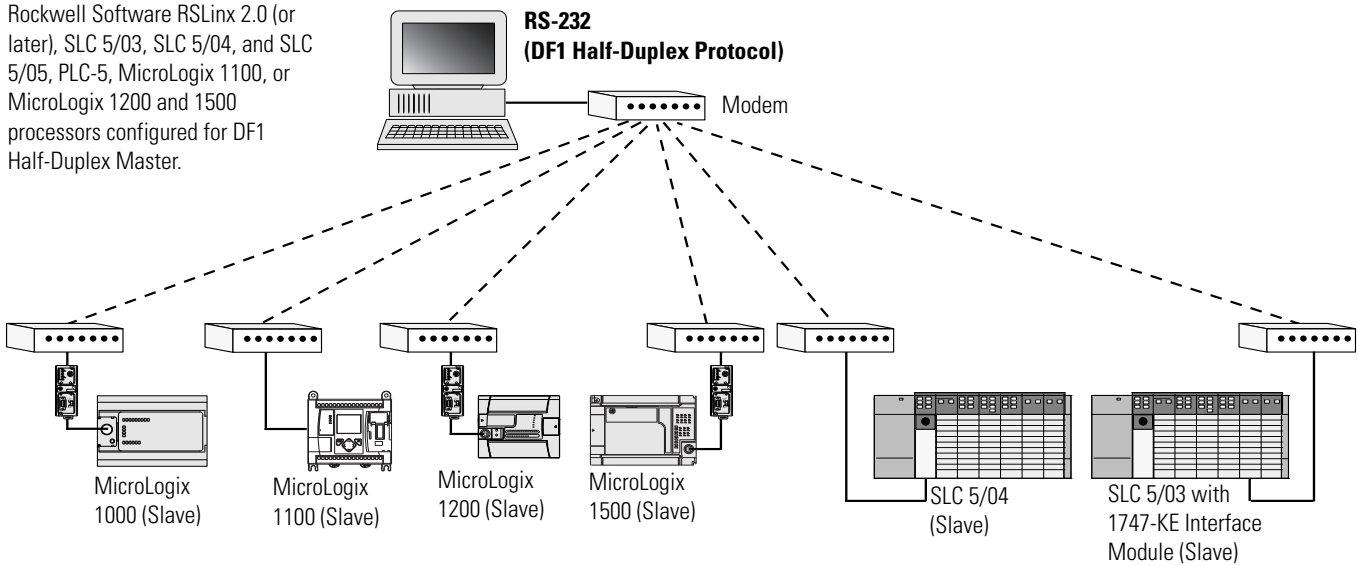

Considerations When Communicating as a DF1 Slave on a Multi-drop Link

When communication is between either your programming software and a MicroLogix Programmable Controller or between two MicroLogix 1100 Programmable Controllers via slave-to-slave communication on a larger multi-drop link, the devices depend on a DF1 Half-Duplex Master to give each of them access in a timely manner. As the number of slave devices increase, the time between when slave devices are polled also increases. This increase in time may also be large if you are using low baud rates. As these time periods grow, you may need to increase the poll timeout and reply timeout values for slave devices.

IMPORTANT

If a program download is started when using DF1 Half-Duplex, but then is interrupted due to electromagnetic interference or other events, discontinue communications to the controller for the *ownership timeout* period and then restart the program download. The *ownership timeout* period is 60 seconds. After the timeout, you can re-establish communications with the processor and try the program download again. The only other way to remove program ownership is to cycle power on the processor.

Using Modems with MicroLogix™ Programmable Controllers

The types of modems you can use with MicroLogix™ controllers include the following:

- dial-up phone modems.
A MicroLogix™ controller, on the receiving end of the dial-up connection, can be configured for DF1 Full-Duplex protocol with or without handshaking. The modem connected to the MicroLogix controller should support auto-answer. The MicroLogix 1100 supports ASCII out communications. Therefore, it can cause a modem to initiate or disconnect a phone call.
- leased-line modems.
Leased-line modems are used with dedicated phone lines that are typically leased from the local phone company. The dedicated lines may be in a point-to-point topology supporting Full-Duplex communications between two modems or in a multi-drop topology supporting Half-Duplex communications between three or more modems.
- radio modems.
Radio modems may be implemented in a point-to-point topology supporting either Half-Duplex or Full-Duplex communications, or in a multi-drop topology supporting Half-Duplex communications between three or more modems. MicroLogix 1100 also supports DF1 Radio Modem protocol.
- line drivers.
Line drivers, also called short-haul modems, do not actually modulate the serial data, but rather condition the electrical signals to operate reliably over long transmission distances (up to several miles). Line drivers are available in Full-Duplex and Half-Duplex models. Allen-Bradley's AIC+ Advanced Interface Converter is a Half-Duplex line driver that converts an RS-232 electrical signal into an RS-485 electrical signal, increasing the signal transmission distance from 50 to 4000 feet (8000 feet when bridged).

For point-to-point Full-Duplex modem connections that do not require any modem handshaking signals to operate, use DF1 Full-Duplex protocol with no handshaking. For point-to-point Full-Duplex modem connections that require RTS/CTS handshaking, use DF1 Full-Duplex protocol with handshaking.

For radio modem connections, use DF1 Radio Modem protocol, especially if store and forward capability is required.

For general multi-drop modem connections, or for point-to-point modem connections that require RTS/CTS handshaking, use DF1 Half-Duplex slave protocol. In this case, one (and only one) of the other devices must be configured for DF1 Half-Duplex master protocol.

IMPORTANT

Never attempt to use DH-485 protocol through modems under any circumstance.

TIP

All MicroLogix controllers support RTS/CTS modem handshaking when configured for DF1 Full-Duplex protocol with the control line parameter set to Full-Duplex Modem Handshaking or DF1 Half-Duplex slave protocol with the control line parameter set to “Half-Duplex Modem”. No other modem handshaking lines (i.e. Data Set Ready and Data Terminal Ready) are supported by MicroLogix 1100 controller. MicroLogix 1100 controller also does not support DCD (Data Carrier Detect).

DH-485 Communication Protocol

The DH-485 protocol defines the communication between multiple devices that coexist on a single pair of wires. DH-485 protocol uses RS-485 Half-Duplex as its physical interface. (RS-485 is a definition of electrical characteristics; it is *not* a protocol.) RS-485 uses devices that are capable of co-existing on a common data circuit, thus allowing data to be easily shared between devices.

The DH-485 network offers:

- interconnection of 32 devices
- multi-master (peer-to-peer) capability
- token passing access control
- the ability to add or remove nodes without disrupting the network
- maximum network segment of 1,219 m (4,000 ft.)

The DH-485 protocol supports two classes of devices: initiators and responders. All initiators on the network get a chance to initiate message transfers. To determine which initiator has the right to transmit, a token passing algorithm is used.

Control of message transfers on the DH-485 network is performed by rotating the token along the nodes on the network. A node holding the token can send a message onto the network. Each node is allowed a fixed number of transmissions (based on the Token Hold Factor) each time it receives the token. After a node sends a message, it passes the token to the next device.

The allowable range of node addresses is 1 to 31. There must be at least one initiator on the network (such as a MicroLogix controller, or an SLC 5/02 or later processor).

DH-485 Configuration Parameters

When MicroLogix communications are configured for DH-485, the following parameters can be changed:

DF1 Full-Duplex Configuration Parameters

Parameter	Options
Baud Rate	9600, 19.2K
Node Address	1 to 31 decimal
Token Hold Factor	1 to 4

See [Software Considerations on page 212](#) for tips on setting the parameters listed above.

Devices that use the DH-485 Network

In addition to the MicroLogix™ controllers, the devices shown in the following table also support the DH-485 network.

Allen-Bradley Devices that Support DH-485 Communication

Catalog Number	Description	Installation	Function	Publication
Bulletin 1761 Controllers	MicroLogix 1000	Series C or later	These controllers support DH-485 communications.	1761-6.3
Bulletin 1762	MicroLogix 1200	Series A or later	These controllers support DH-485 communications.	1762-UM001
Bulletin 1764	MicroLogix 1500	Series A or later	These controllers support DH-485 communications.	1764-UM001
Bulletin 1747 Processors	SLC 500 Processors	SLC Chassis	These processors support a variety of I/O requirements and functionality.	1747-UM011
1746-BAS	BASIC Module	SLC Chassis	Provides an interface for SLC 500 devices to foreign devices. Program in BASIC to interface the 3 channels (2 RS232 and 1 DH-485) to printers, modems, or the DH-485 network for data collection.	1746-UM004 1746-PM001 1746-RM001
2760-RB	Flexible Interface Module	(1771) PLC Chassis	Provides an interface for SLC 500 (using protocol cartridge 2760-SFC3) to other A-B PLCs and devices. Three configurable channels are available to interface with Bar Code, Vision, RF, Dataliner™, and PLC systems.	1747-6.12 2760-ND001
1784-PKTX, -PKTXD	PC DH-485 IM	PCI Computer Bus	Provides DH-485 using RSLinx.	1784-6.5.22
1784-PCMK	PCMCIA IM	PCMCIA slot in computer	Provides DH-485 using RSLinx.	1784-6.5.19
2711-K5A2, -B5A2, -K5A5, -B5A5, -K5A1, -B5A1, -K9A2, -T9A2, -K9A5, -T9A5, -K9A1, and -T9A1	PanelView 550 and PanelView 900 Operator Terminals	Panel Mount	Provides electronic operator interface for SLC 500 processors.	2711-UM014

NA = Not Applicable

Important DH-485 Network Planning Considerations

Carefully plan your network configuration before installing any hardware. Some of the factors that can affect system performance are:

- amount of electrical noise, temperature, and humidity in the network environment.
- number of devices on the network.
- connection and grounding quality in installation.
- amount of communication traffic on the network.

- type of process being controlled.
- network configuration.

The major hardware and software issues you need to resolve before installing a network are discussed in the following sections.

Hardware Considerations

You need to decide the length of the communication cable, where you route it, and how to protect it from the environment where it will be installed.

When the communication cable is installed, you need to know how many devices are to be connected during installation and how many devices will be added in the future. The following sections help you understand and plan the network.

Number of Devices and Length of Communication Cable

The maximum length of the communication cable is 1219 m (4000 ft). This is the total cable distance from the first node to the last node in a segment. However, two segments can be used to extend the DH-485 network to 2438 m (8000 ft.). For additional information on connections using the AIC+, refer to the Advanced Interface Converter (AIC+) User Manual, publication 1761-6.4.

Planning Cable Routes

Follow these guidelines to help protect the communication cable from electrical interference:

- Keep the communication cable at least 1.52 m (5 ft.) from any electric motors, transformers, rectifiers, generators, arc welders, induction furnaces, or sources of microwave radiation.
- If you must run the cable across power feed lines, run the cable at right angles to the lines.
- If you do not run the cable through a contiguous metallic wireway or conduit, keep the communication cable at least 0.15 m (6 in.) from AC power lines of less than 20 A, 0.30 m (1 ft.) from lines greater than 20 A, but only up to 100K VA, and 0.60 m (2 ft.) from lines of 100 K VA or more.
- If you run the cable through a contiguous metallic wireway or conduit, keep the communication cable at least 0.08 m (3 in.) from AC power lines of less than 20 A, 0.15 m (6 in.) from lines greater than 20 A, but only up to 100 K VA, and 0.30 m (1 ft.) from lines of 100 K VA or more.

Running the communication cable through conduit provides extra protection from physical damage and electrical interference. If you route the cable through conduit, follow these additional recommendations:

- Use ferromagnetic conduit near critical sources of electrical interference. You can use aluminum conduit in non-critical areas.
- Use plastic connectors to couple between aluminum and ferromagnetic conduit. Make an electrical connection around the plastic connector (use pipe clamps and the heavy gauge wire or wire braid) to hold both sections at the same potential.
- Ground the entire length of conduit by attaching it to the building earth ground.
- Do not let the conduit touch the plug on the cable.
- Arrange the cables loosely within the conduit. The conduit should contain only serial communication cables.
- Install the conduit so that it meets all applicable codes and environmental specifications.

For more information on planning cable routes, see *Industrial Automation Wiring and Grounding Guidelines*, publication 1770-4.1.

Software Considerations

Software considerations include the configuration of the network and the parameters that can be set to the specific requirements of the network. The following are major configuration factors that have a significant effect on network performance:

- number of nodes on the network
- addresses of those nodes
- baud rate

The following sections explain network considerations and describe ways to select parameters for optimum network performance (speed). See your programming software's user manual for more information.

Number of Nodes

The number of nodes on the network directly affects the data transfer time between nodes. Unnecessary nodes (such as a second programming terminal that is not being used) slow the data transfer rate. The maximum number of nodes on the network is 32.

Setting Node Addresses

The best network performance occurs when node addresses are assigned in sequential order. Initiators, such as personal computers, should be assigned the

lowest numbered addresses to minimize the time required to initialize the network. The valid range for the MicroLogix™ controllers is 1...31 (controllers cannot be node 0). The default setting is 1. The node address is stored in the controller Communications Status file (CS0:5/0 to CS0:5/7).

Setting Controller Baud Rate

The best network performance occurs at the highest baud rate, which is 19,200. This is the default baud rate for a MicroLogix™ device on the DH-485 network. All devices must be at the same baud rate. This rate is stored in the controller Communications Status file (CS0:5/8 to CS0:5/15).

Setting Maximum Node Address

Once you have an established network set up and are confident that you will not be adding more devices, you may enhance performance by adjusting the maximum node address of your controllers. It should be set to the highest node address being used.

IMPORTANT

All devices should be set to the same maximum node address.

MicroLogix Remote Packet Support

MicroLogix™ controllers can respond and initiate with communications (or commands) that do not originate on the local DH-485 network. This is useful in installations where communication is needed between DH-485 and DH+ networks.

The example below shows how to send messages from a device on the DH+ network to a MicroLogix controller on the DH-485 network. This method uses an SLC 5/04 processor as the bridge connection.

When using this method (as shown in the illustration below):

- PLC-5 devices can send read and write commands to MicroLogix™ controllers.
- MicroLogix™ controllers can respond to MSG instructions received.
- The MicroLogix™ controllers can initiate MSG instructions to devices on the DH+ network.
- PC can send read and write commands to MicroLogix™ controllers.
- PC can do remote programming of MicroLogix™ controllers.

TIP

Use a 1763-NC01 Series A or later cable to connect a MicroLogix 1100 controller to a DH-485 network.

You can connect a MicroLogix 1100 controller to your DH-485 network directly without using a RS-232 to RS-485 converter and optical isolator, such as the AIC+, catalog number 1761-NET-AIC, as shown in the illustration below, because Channel 0 has isolation and RS-485 built-in.

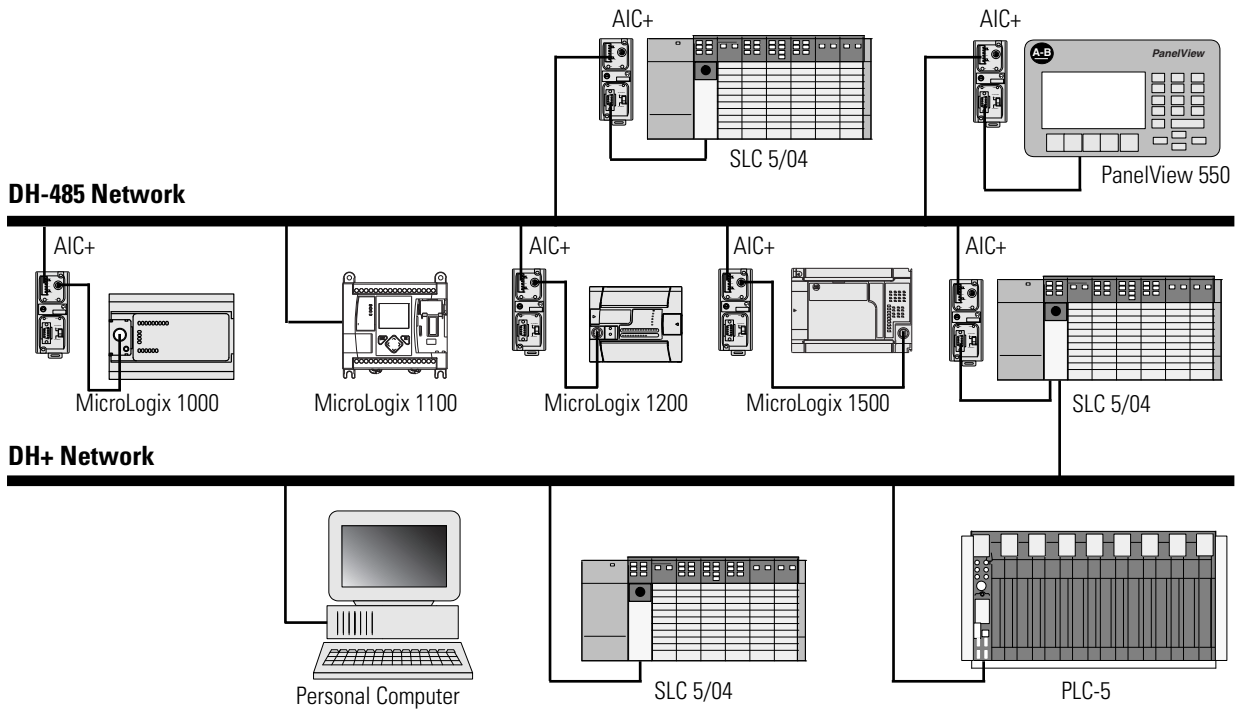

Example DH-485 Connections

The following network diagrams provide examples of how to connect MicroLogix™ controllers to the DH-485 network. You can connect a MicroLogix 1100 controller to your DH-485 network directly without using a RS-232 to RS-485 converter and optical isolator, such as the Advanced Interface Converter (AIC+), catalog number 1761-NET-AIC, as shown in the illustrations below, because Channel 0 has isolation and RS-485 built-in.

However, you may need to use an AIC+ to connect other controllers to a DH-485 network. For more information on the AIC+, see the Advanced Interface Converter and DeviceNet Interface Installation Instructions, Publication 1761-5.11.

DH-485 Network with a MicroLogix™ Controller

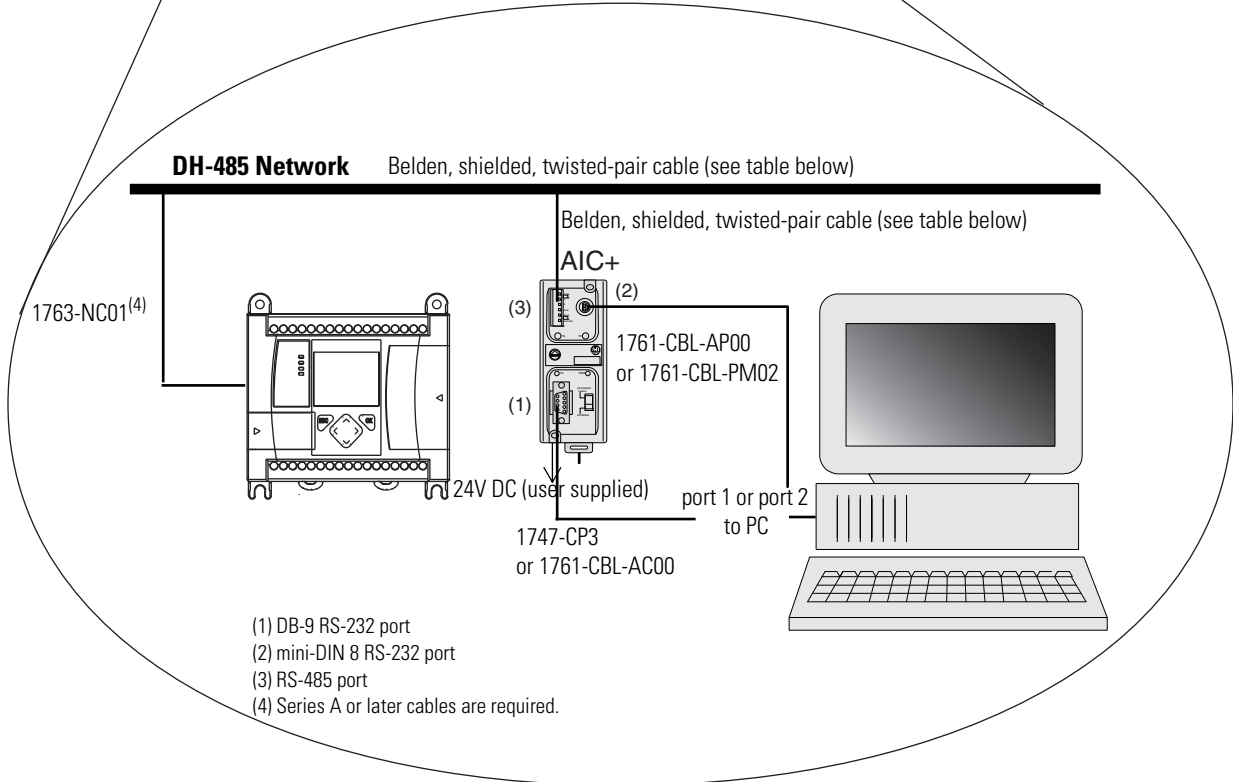
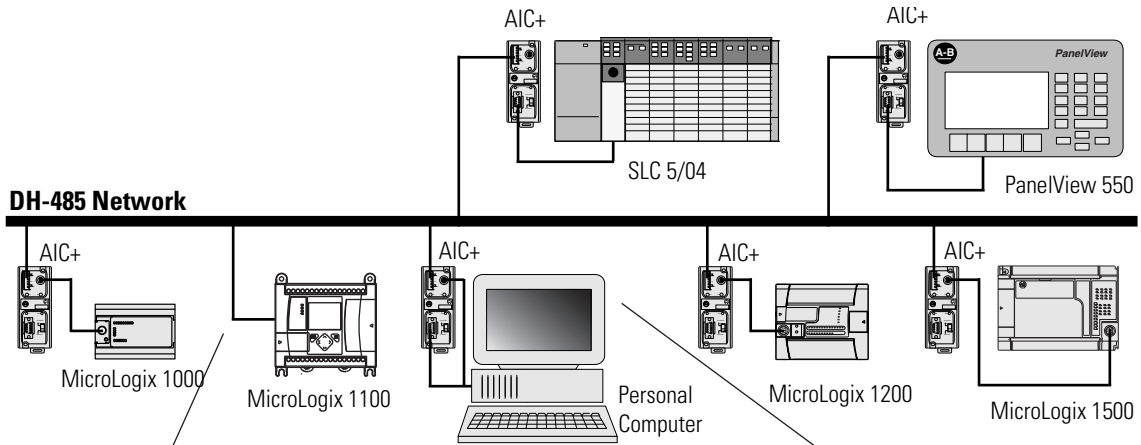

- (1) DB-9 RS-232 port
- (2) mini-DIN 8 RS-232 port
- (3) RS-485 port
- (4) Series A or later cables are required.

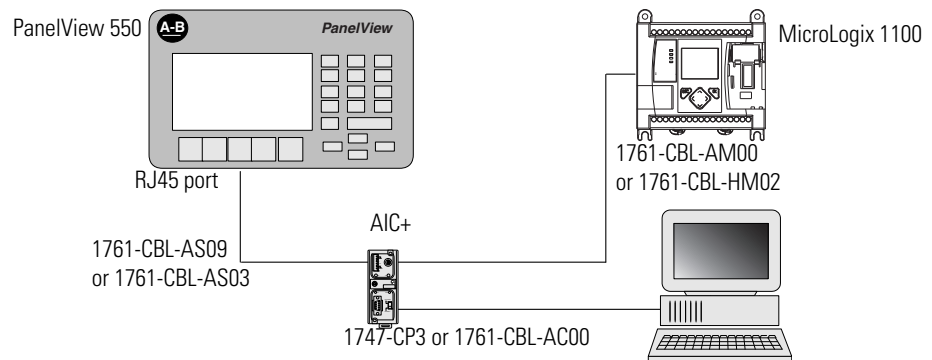
Typical 3-Node Network**TIP**

This 3-node network is not expandable.

Modbus Communication Protocol

Modbus is a Half-Duplex, master-slave communications protocol. The Modbus network master reads and writes coils and registers. Modbus protocol allows a single master to communicate with a maximum of 247 slave devices. MicroLogix 1100 controllers support Modbus RTU Master and Modbus RTU Slave protocol.

For more information on configuring your MicroLogix 1100 controller for Modbus protocol, refer to the MicroLogix 1100 Programmable Controllers Instruction Set Reference Manual, publication 1763-RM001. For more information about the Modbus protocol, see the Modbus Protocol Specifications (available from <http://www.modbus.org>).

ASCII

ASCII provides connection to other ASCII devices, such as bar code readers, weigh scales, serial printers, and other intelligent devices.

You can use ASCII by configuring the RS-232/485 port, channel 0 for ASCII driver. Refer to the MicroLogix 1100 Programmable Controllers Instruction Set Reference Manual, publication 1763-RM001 for detailed configuration information.

Connecting to Networks via Ethernet Interface

This appendix:

- describes MicroLogix 1100 controllers and Ethernet communication.
- describes MicroLogix 1100 performance considerations.
- describes Ethernet network connections and media.
- explains how the MicroLogix 1100 establishes node connections.
- lists Ethernet configuration parameters and procedures.
- describes configuration for subnet masks and gateways.

MicroLogix 1100 Controllers and Ethernet Communication

Ethernet is a local area network that provides communication between various devices at 10 to 100 Mbps. The physical communication media options for the MicroLogix 1100 are:

- built-in
 - twisted-pair (10/100Base-T)
- with media converters or hubs
 - fiber optic
 - broadband
 - thick-wire coaxial cable (10Base-5)
 - thin-wire coaxial cable (10Base-2)

See the following page for more information on Ethernet physical media.

The MicroLogix 1100 supports Ethernet communication via the Ethernet communication channel 1 shown in the drawing below.

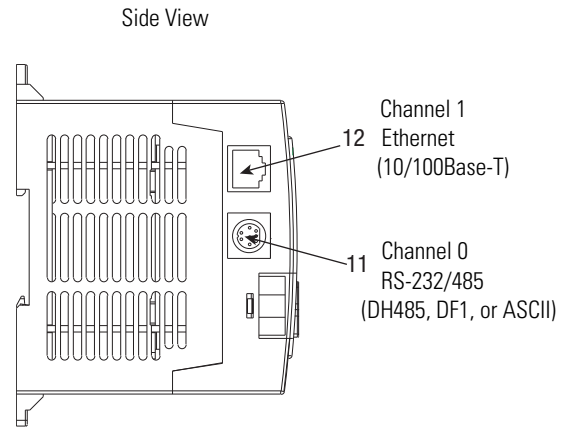

MicroLogix 1100 Performance Considerations

Actual performance of an MicroLogix 1100 controller varies according to:

- size of Ethernet messages.
- frequency of Ethernet messages.
- network loading.
- the implementation of and performance of your processor application program.

Optimal Performance: RSLinx to MicroLogix 1100 Series A OS FRN3 controller(2-node Ethernet network)

Operation	Words	MSG per Second	Words per Second
Single Typed Read	1	20	20
Single Typed Reads	20	20	400
Single Typed Reads	100	20	2000

Optimal Performance: MicroLogix 1100 FRN3 to MicroLogix 1100 Series A OS FRN3 controller(2-node Ethernet network)

Operation	Words	MSG per Second	Words per Second
Single Typed Read	1	11	11
Single Typed Reads	20	11	220
Single Typed Reads	100	11	1,100

Optimal Performance: RSLinx to MicroLogix 1100 Series B OS FRN4 controller

Operation	Words	MSG per Second	Words per Second
Single Typed Read	1	50	50
Single Typed Reads	20	50	2,500
Single Typed Reads	100	50	5,000

Optimal Performance: MicroLogix 1100 Series A OS FRN3 to MicroLogix 1100 Series B OS FRN4 controller

Operation	Words	MSG per Second	Words per Second
Single Typed Read	1	18	18
Single Typed Reads	20	18	360
Single Typed Reads	100	18	1,800

Optimal Performance: MicroLogix 1100 Series B OS FRN4 to MicroLogix 1100 Series B OS FRN4 controller

Operation	Words	MSG per Second	Words per Second
Single Typed Read	1	20	20
Single Typed Reads	20	20	400
Single Typed Reads	100	20	2,000

MicroLogix 1100 and PC Connections to the Ethernet Network

The MicroLogix 1100 Ethernet connector conforms to ISO/IEC 8802-3 STD 802.3 and utilizes 10/100Base-T media. Connections are made directly from the MicroLogix 1100 to an Ethernet hub or switch. The network setup is simple and cost effective. Typical network topology is pictured below.

Ethernet Network Topology

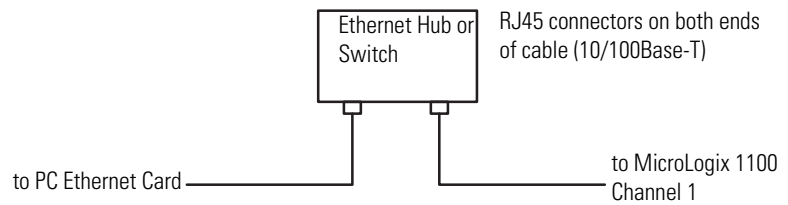

IMPORTANT

The MicroLogix 1100 controller contains a 10/100Base-T, RJ45 Ethernet connector which connects to standard Ethernet hubs or switches via 8-wire twisted-pair straight-through cable. To access other Ethernet mediums, use 10/100Base-T media converters or Ethernet hubs or switches that can be connected together via fiber, thin-wire, or thick-wire coaxial cables, or any other physical media commercially available with Ethernet hubs or switches.

Connecting an Ethernet switch on the Ethernet Network

The MicroLogix 1100 Ethernet port supports the following Ethernet settings:

- 10 Mbps half duplex or full duplex
- 100 Mbps half duplex or full duplex

Mode selection can be automatic, based on the IEEE 802.3 auto negotiation protocol. In most cases, using the auto negotiation function results in proper operation between a switch port and MicroLogix 1100 Ethernet port.

With RSLogix500 programming software version 7.00.00 or later, you can manually set the communication rate and duplex mode of an Ethernet port you have connected to the switch port. The settings of the Ethernet port and the switch port must match.

IMPORTANT

When connecting the MicroLogix 1100 Ethernet port to a 10/100Base-T Ethernet switch, note the following recommendations:

- Use the auto negotiation function for both the switch port and the MicroLogix 1100 Ethernet port
- If you want to force to a specific speed/duplex mode, you should force the MicroLogix 1100 Ethernet port and leave the switch in auto negotiation mode to match speed/duplex settings of the MicroLogix 1100. Ethernet port.
- If you want to disable the auto negotiation function for both ports, then you should only force both the switch and the MicroLogix 1100 port to either 100Mbps Half-duplex or 10 Mbps/Half-duplex.
If you attempt to force both the switch and the MicroLogix1100 port to either 100 Mbps Full-duplex or 10 Mbps Full-duplex, the Ethernet link will not be established and Ethernet communications will not work.

Cables

Shielded and non-shielded twisted-pair 10/100Base-T cables with RJ45 connectors are supported. The maximum cable length between an MicroLogix 1100 Ethernet port and a 10/100Base-T port on an Ethernet hub or switch (without repeaters or fiber) is 100 m (323 ft). However, in an industrial application, cable length should be kept to a minimum.

TIP

The Ethernet cabling with straight-through method is recommended as below. Do *not* make the incorrect connection.

Straight-through cabling

Pin	Pin Name	Cable color
1	Tx+	Orange/White
2	Tx-	Orange
3	Rx+	Green/White
4	No used by 10/100Base-T	Blue
5	No used by 10/100Base-T	Blue/White
6	Rx-	Green
7	No used by 10/100Base-T	Brown/White
8	No used by 10/100Base-T	Brown

The standard Ethernet cable is terminated in accordance with EIA/TIA 568B on both ends. The crossover cable is terminated to EIA/TIA 568B at one end and EIA/TIA 568A at the other, exactly as shown in the two color coded plugs below.

The following figures show how the TIA/EIA 568A and 568B are to be terminated. There are four pairs of wires contained in a CAT5 UTP cable. These pairs of cables are color coded white blue/blue, white orange/orange, white green/green, white brown/brown, they are also numbered one to four in the order shown.

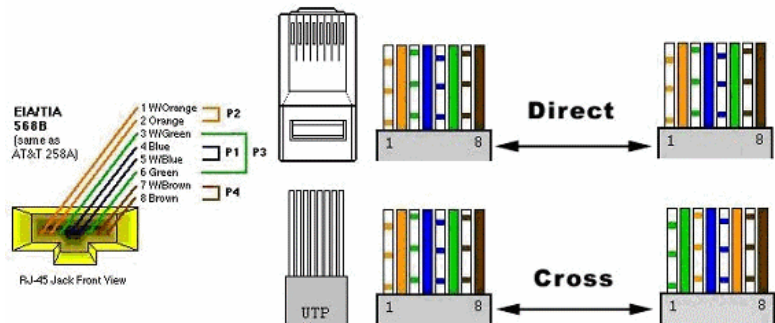
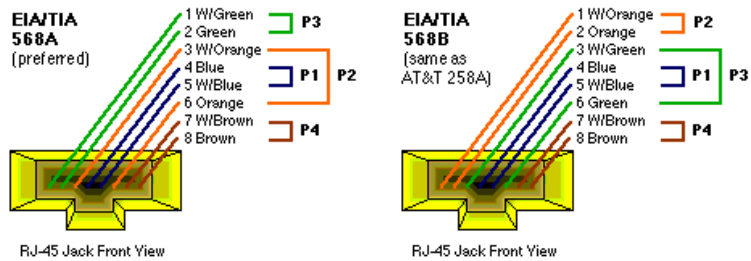

TIP

The most common wiring for RJ45 cables is the "straight through" cable which means that pin 1 of the plug on one end is connected to pin 1 of the plug on the other end. The straight through RJ45 cable is commonly used to connect network cards with hubs on 10Base-T and 100Base-Tx networks. On network cards, pair 1-2 is the transmitter, and pair 3-6 is the receiver. The other two pairs are not used. On hubs pair 1-2 is the receiver and 3-6 the transmitter. It may be best to wire your cables with the same color sequence. In this cable layout, all pins are wired one-to-one to the other side. The pins on the RJ45 connector are assigned in pairs, and every pair carries one differential signal. Each line pair has to be twisted.

In small network where only two computers have to be connected, a "cross over" RJ45 cable is necessary, where the transmit and receive lines on both RJ45 connectors are cross connected. The color coding for the cross over RJ45 cable have been defined in the EIA/TIA 568A standard. In a cross-over cable layout, you should remember that one end is normal, and the other end has the cross-over configuration.

Ethernet Connections

TCP/IP is the mechanism used to transport Ethernet messages. On top of TCP, Ethernet/IP protocol is required to establish sessions and to send the MSG commands. Connections can be initiated by either a client program (RSLinx application) or a processor.

The client program or processor must first establish a connection to the MicroLogix 1100 to enable the MicroLogix 1100 to receive solicited messages from a client program or another processor.

In order to *send* an outgoing message, the MicroLogix 1100 must first establish a connection with the destination node at a specified IP address on the Ethernet network. A connection is established when a MSG instruction executes and no previous connection exists.

When a MSG instruction executes, the MicroLogix 1100 checks to see whether a connection has been established with the destination node. If a connection has not been established, the MicroLogix 1100 attempts to establish a connection of the peer type.

In order to *receive* messages from another device on Ethernet, an “incoming” connection must be established. This incoming connection is made by the sending processor and uses one incoming connection in the receiving processor.

The MicroLogix 1100 supports a maximum of 32 connections, allowing a maximum of 16 outgoing and a maximum of 16 incoming simultaneous connections with up to 32 other devices or applications. The connections are dedicated as follows:

Number of Connections ⁽¹⁾	Dedicated to:
16	outgoing connections
16	incoming connections

⁽¹⁾ Connections established by an INTERCHANGE client, RSLinx client, and peers are all included when counting the number of connections.

IMPORTANT

For outgoing connections, no more than one connection per destination node is established. If multiple MSG instructions use the same destination node, they share the same connection.

Duplicate IP address Detection

The MicroLogix 1100 Series B firmware support duplicate IP address detection.

When you change the IP address or connect one of the MicroLogix to an EtherNet/IP network, the MicroLogix 1100 controller checks to make sure that the IP address assigned to this device does not match the address of any other network device. The MicroLogix 1100 will check every 2 minutes for a duplicate IP address on the network. If the MicroLogix 1100 determines that there is a conflict (another device on the network with a matching IP address), the following message gets posted on the LCD display.

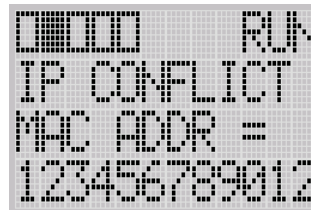

To correct this conflict, use the instructions in this chapter to change the IP address of the Ethernet/IP device. Then cycle power to the device or reset the device (such as disconnecting the ethernet cable and reconnecting the cable).

There is also the possibility that two Ethernet/IP device can detect a conflict simultaneously. If this occurs, remove the device with the incorrect IP address or correct its conflict. To get the second device out of conflict mode, cycle power to the module or disconnect its ethernet cable and reconnect the cable.

The MicroLogix 1100 will check every 2 minutes for a duplicate IP address on the network.

Configuring the Ethernet Channel on the MicroLogix 1100

There are two ways to configure the MicroLogix 1100 Ethernet channel 1.

- via a BOOTP or DHCP request at controller powerup
- manually setting the configuration parameters using RSLogix 500 Programming Software

The configuration parameters are shown on the following page, and the configuration procedures follow.

Parameter	Description	Default	Status
Hardware Address	The MicroLogix 1100 Ethernet hardware address.	Ethernet hardware address	read only
IP Address	The MicroLogix 1100 internet address (in network byte order). The internet address must be specified to connect to the TCP/IP network.	0 (undefined)	read/write
Subnet Mask	The MicroLogix 1100 subnet mask (in network byte order). The Subnet Mask is used to interpret IP addresses when the internet is divided into subnets. A Subnet Mask of all zeros indicates that no subnet mask has been configured.	0 (undefined)	read/write
Gateway Address	The address of a gateway (in network byte order) that provides connection to another IP network. A Gateway Address of all zeros indicates that no gateway has been configured.	0 (undefined)	read/write
Default Domain Name	The default domain name can have the following formats: 'a.b.c', 'a.b' or 'a', where a, b, c must start with a letter, end with a letter or digit, and have as interior characters only letters, digits or hyphens. Maximum length is 63 characters.	NULL (undefined)	read/write
Primary Name Server	This is the IP address of the computer acting as the local Ethernet network Primary Domain Name System (DNS) server.	0 (undefined)	read/write
Secondary Name Server	This is the IP address of the computer acting as the local Ethernet network Secondary Domain Name System (DNS) server.	0 (undefined)	read/write
BOOTP Enable	The BOOTP enable switch. When BOOTP is enabled, the MicroLogix 1100 attempts to learn its network related parameters at powerup via a BOOTP request. There must be a BOOTP server on the network capable of responding to this BOOTP request. When both BOOTP and DHCP are disabled, the MicroLogix 1100 uses the locally configured network related parameters (IP Address, Subnet Mask, Broadcast Address, etc.).	1 (enabled)	read/write
DHCP Enable	The DHCP auto configuration enable switch. When DHCP is enabled, a DHCP server automatically assigns network related parameters to the MicroLogix 1100 when it logs into a TCP/IP network. There must be a DHCP server on the network capable of allocating network addresses and configuring parameters to newly attached device. When both BOOTP and DHCP are disabled, the MicroLogix 1100 uses the locally configured network related parameters (IP Address, Subnet Mask, Broadcast Address, etc.).	0 (disabled)	read/write
SNMP Server Enable	SNMP enable switch. Check this to enable SNMP (Simple Network Management Protocol). Not applicable to the MicroLogix 1100.	0 (disabled)	read/write

Parameter	Description	Default	Status
SMTP Client Enable (Series B only)	The SMTP Client service enable switch. When SMTP is enabled, MicroLogix 1100 is capable of transmitting e-mail messages generated by a 485CIF write message with a string element. There must be a SMTP server on the network capable of processing e-mail service. This provides an extremely versatile mechanism to report alarms, status, and other data-related functions.	0 (disabled)	read/write
Auto Negotiate and Port Setting	When Auto Negotiate is disabled (unchecked), the Ethernet speed/duplex is forced to either 10 Mbps/Half-duplex, 10 Mbps/Full-duplex, 100 Mbps/Half-duplex, or 100 Mbps/Full-duplex, as selected in the Port Setting field. When Auto Negotiate is enabled (checked), the Port Setting Field allows you to select the range of speed/duplex settings that the MicroLogix 1100 will negotiate.	Auto Negotiate enabled and Port Setting. 10/100 Mbps Full Duplex/Half Duplex	read/write
MSG Connection Timeout	The amount of time (in ms) allowed for a MSG instruction to establish a connection with the destination node. The MSG Connection Timeout has 250 ms resolution and a range from 250 to 65,500.	15,000 ms	read/write
MSG Reply Timeout	The amount of time (in ms) that the MicroLogix 1100 will wait for a reply to a command that it has initiated via a MSG instruction. The MSG Reply Timeout has 250 ms resolution and a range from 250 to 65,500.	3,000 ms	read/write
Inactivity Timeout (Series B only)	The amount of time (in minutes) that a MSG connection may remain inactive before it is terminated. The Inactivity Timeout has a 1 minute resolution and a range from 1 to 65,500 minutes.	30 minutes.	read/write

Configuration Using RSLogix 500 Programming Software

Refer to the online documentation provided with your programming software.

Configuration Via BOOTP

BOOTP (bootstrap protocol) is a low-level protocol that TCP/IP nodes use to obtain start-up information. By default, the MicroLogix 1100 broadcasts BOOTP requests at powerup. The BOOTP Valid parameter remains clear until a BOOTP reply has been received. BOOTP lets you dynamically assign IP Addresses to processors on the Ethernet Link.

To use BOOTP, a BOOTP Server must exist on the local Ethernet subnet. The server is a computer that has BOOTP Server software installed and reads a text file containing network information for individual nodes on the network.

The host system's BOOTP configuration file must be updated to service requests from MicroLogix 1100 controllers. The following parameters must be configured:

Parameter	Description
IP Address	A unique IP Address for the MicroLogix 1100 controller.
Subnet Mask	Specifies the net and local subnet mask as per the standard on subnetting RFC 950, Internet Standard Subnetting Procedure.
Gateway	Specifies the IP address of a gateway on the same subnet as the MicroLogix 1100 that provides connections to another IP network.

TIP

You can use any commercially available BOOTP server. If you do not have BOOTP Server capabilities on your network, and you want to dynamically configure Channel 1, you can download the free Rockwell Automation BOOTP server from the Rockwell Automation website. Go to www.ab.com/networks/bootp/index.html

When BOOTP is enabled, the following events occur at power-up:

- The processor broadcasts a BOOTP-request message containing its hardware address over the local network or subnet.
- The BOOTP server compares the hardware address with the addresses in its look-up table.
- The BOOTP server sends a message back to the processor with the IP address and other network information that corresponds to the hardware address it received.

With all hardware and IP addresses in one location, you can easily change IP addresses in the BOOTP configuration file if your network needs to be changed.

The BOOTP request can be disabled by clearing the BOOTP Enable parameter in the channel configuration file. When both BOOTP Enable and DHCP are cleared (disabled), the MicroLogix 1100 uses the existing channel configuration data.

IMPORTANT

If BOOTP is disabled, or no BOOTP server exists on the network, you must use RSLogix 500 programming software to enter/change the IP address for each processor or you must use DHCP instead of it.

Using the Rockwell BOOTP/DHCP Utility

The Rockwell BOOTP/DHCP server utility is a standalone program that incorporates the functionality of standard BOOTP software with a user-friendly graphical interface. It is located in the **Utils** directory on the RSLogix 500 installation CD.

The newest version of the utility can be downloaded from www.ab.com/networks/bootp/index.html. The device must have BOOTP enabled (factory default) or DHCP enabled to use the utility.

To configure your device using the BOOTP utility, perform the following steps.

1. Run the BOOTP/DHCP server utility software. It will ask you to configure your network settings before using the BOOTP/DHCP server tool. Enter your Ethernet settings for Subnet Mask and Gateway. If you are not sure about it, get a help from your system administrator. Just leave Primary DNS, Secondary DNS, and Domain Name (If corresponding information is allocated to the PC where BOOTP/DHCP server utility is installed, enter the same information.)

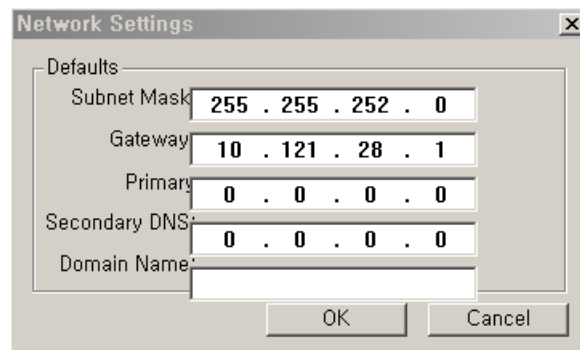

Defaults	
Subnet Mask	255 . 255 . 252 . 0
Gateway	10 . 121 . 28 . 1
Primary	0 . 0 . 0 . 0
Secondary DNS	0 . 0 . 0 . 0
Domain Name	

- In the **Request History** panel you will see the hardware addresses of devices issuing BOOTP or DHCP requests.

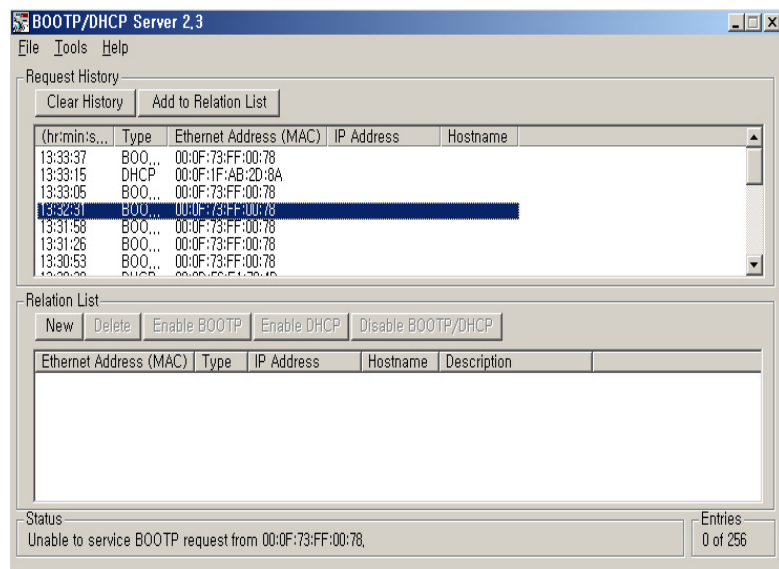

- Double-click on the hardware address of the device you want to configure. You will see the **New Entry** pop-up window with the device's Ethernet Address (MAC).

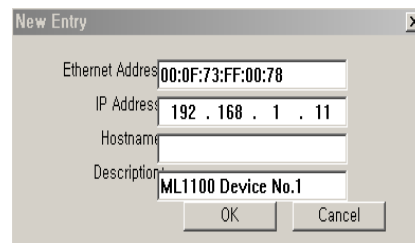

- Enter the **IP Address** and **Description** you want to assign to the device, and click **OK**. Leave Hostname blank.

The device will be added to the **Relation List**, displaying the Ethernet Address (MAC) and corresponding IP Address, Subnet Mask, and Gateway (if applicable).

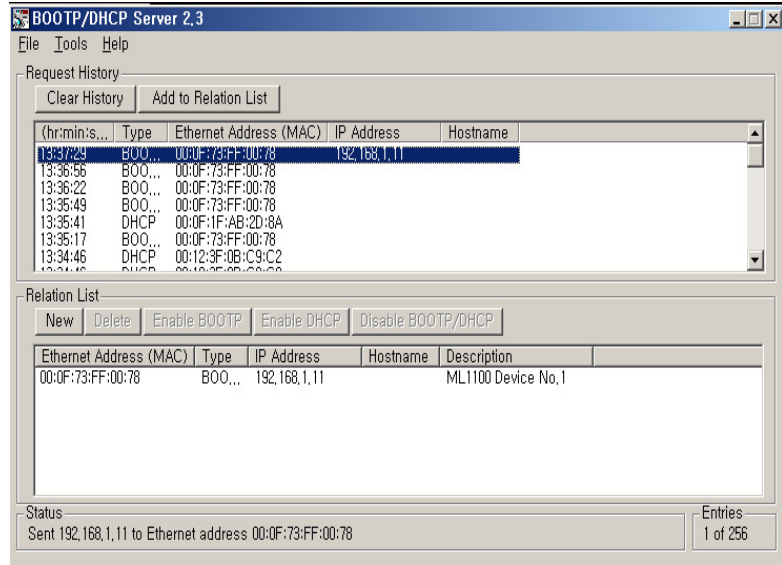

Using a DHCP Server To Configure Your Processor

A DHCP server automatically assigns IP addresses to client stations logging onto a TCP/IP network. DHCP is based on BOOTP and maintains some backward compatibility. The main difference is that BOOTP was designed for manual configuration, while DHCP allows for dynamic allocation of network addresses and configurations to newly attached devices.

ATTENTION



The processor must be assigned a fixed network address. The IP address of the processor must not be dynamically provided. *Failure to observe this precaution may result in unintended machine motion or loss of process control.*

Using Subnet Masks and Gateways

Configure subnet masks and gateways using the Ethernet channel 1 configuration screen.

IMPORTANT

If BOOTP is enabled, you can't change any of the advanced Ethernet communications characteristics.

If your network is divided into subnetworks that use gateways or routers, you must indicate the following information when configuring channel 1:

- subnet mask
- gateway address

A *subnet mask* is a filter that a node applies to IP addresses to determine if an address is on the local subnet or on another subnet. If an address is located on another subnetwork, messages are routed through a local gateway to be transferred to the destination subnetwork.

If your network is not divided into subnets, then leave the subnet mask field at the default.

If you are	Then
manually configuring channel 1 and have a network with subnets	<ul style="list-style-type: none"> • be sure the BOOTP enable field is disabled • use your programming software to enter the subnet mask and gateway address.
using BOOTP to configure channel 1 and have a network with subnets	<ul style="list-style-type: none"> • be sure BOOTP is enabled • include the subnet mask(s) and gateway address(es)

Manually Configuring Channel 1 for Controllers on Subnets

If you are manually configuring channel 1 for a MicroLogix 1100 controller located on a subnet, deselect both of the “BOOTP Enable” and “DHCP Enable” options by clicking on the checked box, as shown in the figure below.

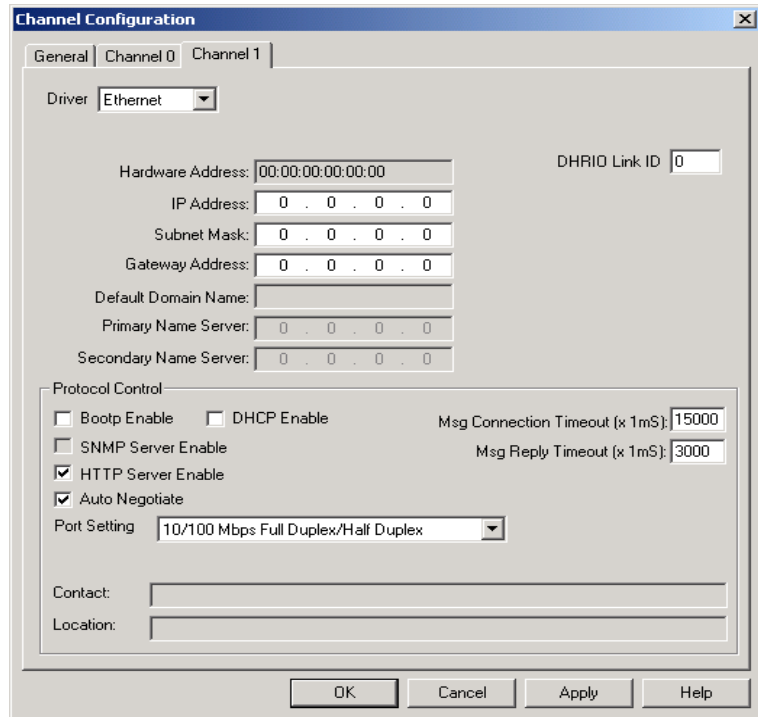

See the table below to configure the subnet mask and gateway address fields for each controller via your programming software.

This field:	Specifies:	Configure by doing the following:
Subnet Mask	The controller’s subnet mask. The subnet mask is used to interpret IP addresses when the internet is divided into subnets.	Enter an address of the following form: a.b.c.d Where: a, b, c, d are between 0...255 (decimal) If your network is not divided into subnets, then leave the subnet mask field at the default. If you change the default and need to reset it, type 0.0.0.0.
Gateway Address	The IP address of the gateway that provides a connection to another IP network. This field is required when you communicate with other devices not on a local subnet.	Enter an address of the following form: a.b.c.d Where: a, b, c, d are between 0...255 (decimal) The default address is No Gateway.

MicroLogix 1100 Embedded Web Server Capability

MicroLogix 1100 controllers include not only the embedded web server which allows viewing of module information, TCP/IP configuration, and diagnostic information, but the capabilities that also allow viewing of the data file via Ethernet using a standard web browser.

For more information on MicroLogix 1100 embedded web server capability, refer to the *MicroLogix 1100 Programmable Controllers Embedded Web Server User Manual*, publication 1763-UM002.

Notes:

System Loading and Heat Dissipation

TIP

A maximum of four 1762 I/O modules, in *any* combination, can be connected to a MicroLogix 1100 controller. You can use this appendix to determine the power supply load and heat dissipation for your system.

System Loading Calculations

The MicroLogix 1100 controller is designed to support up to any four 1762 expansion I/O modules.

When you connect MicroLogix accessories and expansion I/O, an electrical load is placed on the controller power supply. This section shows how to calculate the load of your control system.

The following example is provided to illustrate system loading calculation. The system calculation procedure accounts for the amount of 5V DC and 24V DC current consumed by controller, expansion I/O, and user-supplied equipment. Use the System Loading Worksheet on page G-238 to calculate your controller configuration.

System Loading Example Calculations

Current Loading

Calculating the Current for Expansion I/O

Catalog Number ⁽¹⁾	n	A	B	n x A	n x B
	Number of Modules	Device Current Requirements (max)		Calculated Current	
		at 5V DC (mA)	at 24V DC (mA)	at 5V DC (mA)	at 24V DC (mA)
1762-IA8	2	50	0	100	0
1762-IF4		40	50		
1762-IF20F2		40	105		
1762-IQ8		50	0		
1762-IQ16		70 ⁽²⁾	0		
1762-IQ32T		170	0		
1762-IR4		40	50		
1762-IT4		40	50		
1762-OA8		115	0		
1762-OB8		115	0		
1762-OB16		175	0		
1762-OB32T		175	0		
1762-OF4		40	165		
1762-OV32T		175	0		
1762-OW8	2	80	90	160	180
1762-OW16		140 ⁽²⁾	180 ⁽²⁾		
1762-OX6I		110	110		
1762-IQ8OW6		110	80		
Total Modules (4 maximum):	4	Subtotal:		260	180

(1) Refer to your expansion I/O Installation Instructions for Current Requirements not listed in this table.

(2) Only applicable to Series B I/O modules.

Validating the System

The example systems shown in the tables below are verified to be acceptable configurations. The systems are valid because:

- *Calculated Current Values < Maximum Allowable Current Values*
- *Calculated System Loading < Maximum Allowable System Loading*

Validating Systems using 1763-L16AWA, 1763-L16BBB, or 1763-L16DWD

Maximum Allowable Values		Calculated Values	
Current:		Current (Subtotal from Table on page 236.):	
800 mA at 5V DC	700 mA at 24V DC	0 mA + 260 mA = 260 mA at 5V DC	120 mA + 180 mA = 300 mA at 24V DC
System Loading:		System Loading:	
		= (260 mA x 5V) + (300 mA x 24V)	
		= (1,300 mW) + (7,200 mW)	
		= 8,500 mW	
20.8 W		= 8.50 W	

Validating Systems using 1763-L16BWA

Maximum Allowable Values		Calculated Values	
Current for Devices Connected to the +24V DC Sensor Supply:		Sum of all sensor currents	
200 mA at 24V DC		140 mA at 24V DC (example sensor value)	
Current for MicroLogix Accessories and Expansion I/O:		Current Values (Subtotal from Table):	
800 mA at 5V DC	700 mA at 24V DC	0 mA + 260 mA = 260 mA at 5V DC	120 mA + 180 mA = 300 mA at 24V DC
System Loading:		System Loading:	
		= (140 mA x 24V) + (260 mA x 5V) + (300 mA x 24V)	
		= (3,360 mW) + (1,300 mW) + (7,200 mW)	
		= 11,860 mW	
16.4 W		= 11.9 W	

System Loading Worksheet

The tables below are provided for system loading validation. See System Loading Example Calculations on page G-236.

Current Loading

Calculating the Current for Expansion I/O

Catalog Number ⁽¹⁾	n	A	B	n x A	n x B
	Number of Modules	Device Current Requirements		Calculated Current	
		at 5V DC (mA)	at 24V DC (mA)	at 5V DC (mA)	at 24V DC (mA)
1762-IA8		50	0		
1762-IF4		40	50		
1762-IF20F2		40	105		
1762-IQ8		50	0		
1762-IQ16		70 ⁽²⁾	0		
1762-IQ32T		170	0		
1762-IR4		40	50		
1762-IT4		40	50		
1762-OA8		115	0		
1762-OB8		115	0		
1762-OB16		175	0		
1762-OB32T		175	0		
1762-OF4		40	165		
1762-OV32T		175	0		
1762-OW8		80	90		
1762-OW16		140 ⁽²⁾	180 ⁽²⁾		
1762-OX6I		110	110		
1762-IQ8OW6		110	80		
Total Modules (4 maximum):		Subtotal:			

(1) Refer to your expansion I/O Installation Instructions for Current Requirements not listed in this table.

(2) Only applicable to Series B I/O modules.

Validating Systems using 1763-L16AWA, 1763-L16BBB, or 1763-L16DWD

Maximum Allowable Values		Calculated Values	
Current:		Current (Subtotal from Table .):	
800 mA at 5V DC	700 mA at 24V DC	mA at 5V DC	mA at 24V DC
System Loading:		System Loading:	
		= (_____ mA x 5V) + (_____ mA x 24V)	
		= _____ mW + _____ mW	
		= _____ mW	
20.8 W		= _____ W	

Validating Systems using 1763-L16BWA

Maximum Allowable Values		Calculated Values	
Current for Devices Connected to the +24V DC Sensor Supply:		Sum of all sensor currents	
200 mA at 24V DC		mA at 24V DC	
Current for MicroLogix Accessories and Expansion I/O:		Current (Subtotal from Table .)	
800 mA at 5V DC	700 mA at 24V DC	mA at 5 V DC	mA at 24V DC
System Loading:		System Loading:	
		= (_____ mA x 24V) + (_____ mA x 5V) + (_____ mA x 24V)	
		= _____ mW + _____ mW + _____ mW	
		= _____ mW	
16.4 W		= _____ W	

Calculating Heat Dissipation

Use the following table when you need to determine the heat dissipation of your system for installation in an enclosure. For System Loading, take the value from the appropriate system loading worksheets on pages 238 or 239.

Heat Dissipation

Catalog Number	Heat Dissipation		
	Equation or Constant	Calculation	Sub-Total
1763-L16AWA	15.2 W + (0.4 x System Loading)	15.2 W + (0.4 x _____ W)	W
1763-L16BWA	15.7 W + (0.4 x System Loading)	15.7 W + (0.4 x _____ W)	W
1763-L16BBB	17.0 W + (0.3 x System Loading)	17.0 W + (0.3 x _____ W)	W
1763-L16DWD	17.0 W + (0.3 x System Loading)	17.0 W + (0.3 x _____ W)	W
1762-IA8	2.0 W x number of modules	2.0 W x _____	W
1762-IF4	2.0 W x number of modules	2.0 W x _____	W
1762-IF20F2	2.6 W x number of modules	2.6 W x _____	W
1762-IQ8	3.7 W x number of modules	3.7 W x _____	W
1762-IQ16	5.4 W ⁽¹⁾ x number of modules	5.4 W ⁽¹⁾ x _____	W
1762-IQ32T	6.8 W x number of modules (at 30.0V DC)	6.8 W x _____ (at 30.0V DC)	W
	5.4 W x number of modules (at 26.4V DC)	5.4 W x _____ (at 26.4V DC)	W
1762-IR4	1.5 W x number of modules	1.5 W x _____	W
1762-IT4	1.5 W x number of modules	1.5 W x _____	W
1762-OA8	2.9 W x number of modules	2.9 W x _____	W
1762-OB8	1.6 W x number of modules	1.6 W x _____	W
1762-OB16	2.9 W x number of modules	2.9 W x _____	W
1762-OB32T	3.4 W x number of modules	3.4 W x _____	W
1762-OF4	3.8 W x number of modules	3.8 W x _____	W
1762-OV32T	2.7 W x number of modules	2.7 W x _____	W
1762-OW8	2.9 W x number of modules	2.9 W x _____	W
1762-OW16	6.1 W ⁽¹⁾ x number of modules	6.1 W ⁽¹⁾ x _____	W
1762-OX6I	2.8 W x number of modules	2.8 W x _____	W
1762-IQ8OW6	4.4 W x number of modules	4.4 W x _____	W
Add Sub-Totals to determine Heat Dissipation			W

(1) Only applicable to Series B I/O modules.

The following terms are used throughout this manual. Refer to the *Allen-Bradley Industrial Automation Glossary*, publication AG-7.1, for a complete guide to Allen-Bradley technical terms.

address

A character string that uniquely identifies a memory location. For example, I:1/0 is the memory address for the data located in the Input file location word1, bit 0.

AIC+ Advanced Interface Converter

A device that provides a communication link between various networked devices. (Catalog Number 1761-NET-AIC.)

application

- 1) A machine or process monitored and controlled by a controller.
- 2) The use of computer- or processor-based routines for specific purposes.

baud rate

The speed of communication between devices. All devices must communicate at the same baud rate on a network.

bit

The smallest storage location in memory that contains either a 1 (ON) or a 0 (OFF).

block diagrams

A schematic drawing.

Boolean operators

Logical operators such as AND, OR, NAND, NOR, NOT, and Exclusive-OR that can be used singularly or in combination to form logic statements or circuits. Can have an output response of T or F.

branch

A parallel logic path within a rung of a ladder program.

communication scan

A part of the controller's operating cycle. Communication with other devices, such as software running on a personal computer, takes place.

controller

A device, such as a programmable controller, used to monitor input devices and control output devices.

controller overhead

An internal portion of the operating cycle used for housekeeping and set-up purposes.

control profile

The means by which a controller determines which outputs turn on under what conditions.

counter

- 1) An electro-mechanical relay-type device that counts the occurrence of some event. May be pulses developed from operations such as switch closures or interruptions of light beams.
- 2) In controllers, a software counter eliminates the need for hardware counters. The software counter can be given a preset count value to count up or down whenever the counted event occurs.

CPU (Central Processing Unit)

The decision-making and data storage section of a programmable controller.

data table

The part of processor memory that contains I/O values and files where data is monitored, manipulated, and changed for control purposes.

DIN rail

Manufactured according to Deutsche Industrie Normenausschuss (DIN) standards, a metal railing designed to ease installation and mounting of your controller.

download

Data is transferred from a programming or storage device to another device.

DTE (Data Terminal Equipment)

Equipment that is attached to a network to send or receive data, or both.

embedded I/O

Embedded I/O is the controller's on-board I/O.

EMI

Electromagnetic interference.

encoder

- 1) A rotary device that transmits position information.
- 2) A device that transmits a fixed number of pulses for each revolution.

executing mode

Any run or test mode.

expansion I/O

Expansion I/O is I/O that is connected to the controller via a bus or cable. MicroLogix 1200 controllers use Bulletin 1762 expansion I/O.

false

The status of an instruction that does not provide a continuous logical path on a ladder rung.

FIFO (First-In-First-Out)

The order that data is entered into and retrieved from a file.

file

A collection of information organized into one group.

full-duplex

A bidirectional mode of communication where data may be transmitted and received simultaneously (contrast with half-duplex).

half-duplex

A communication link in which data transmission is limited to one direction at a time.

hard disk

A storage area in a personal computer that may be used to save processor files and reports for future use.

high byte

Bits 8 to 15 of a word.

input device

A device, such as a push button or a switch, that supplies signals to the input circuits of the controller.

inrush current

The temporary surge current produced when a device or circuit is initially energized.

instruction

A mnemonic and data address defining an operation to be performed by the processor. A rung in a program consists of a set of input and output instructions. The input instructions are evaluated by the controller as being true or false. In turn, the controller sets the output instructions to true or false.

instruction set

The set of general purpose instructions available with a given controller.

I/O (Inputs and Outputs)

Consists of input and output devices that provide and/or receive data from the controller.

jump

Change in normal sequence of program execution, by executing an instruction that alters the program counter (sometimes called a branch). In ladder programs a JUMP (JMP) instruction causes execution to jump to a labeled rung.

ladder logic

A program written in a format resembling a ladder-like diagram. The program is used by a programmable controller to control devices.

least significant bit (LSB)

The digit (or bit) in a binary word (code) that carries the smallest value of weight.

LED (Light Emitting Diode)

Used as status indicator for processor functions and inputs and outputs.

LIFO (Last-In-First-Out)

The order that data is entered into and retrieved from a file.

low byte

Bits 0 to 7 of a word.

logic

A process of solving complex problems through the repeated use of simple functions that can be either true or false. General term for digital circuits and programmed instructions to perform required decision making and computational functions.

Master Control Relay (MCR)

A mandatory hard-wired relay that can be de-energized by any series-connected emergency stop switch. Whenever the MCR is de-energized, its contacts open to de-energize all application I/O devices.

mnemonic

A simple and easy to remember term that is used to represent a complex or lengthy set of information.

modem

Modulator/demodulator. Equipment that connects data terminal equipment to a communication line.

modes

Selected methods of operation. Example: run, test, or program.

negative logic

The use of binary logic in such a way that “0” represents the voltage level normally associated with logic 1 (for example, 0 = +5V, 1 = 0V). Positive is more conventional (for example, 1 = +5V, 0 = 0V).

network

A series of stations (nodes) connected by some type of communication medium. A network may be made up of a single link or multiple links.

nominal input current

The current at nominal input voltage.

normally closed

Contacts on a relay or switch that are closed when the relay is de-energized or the switch is deactivated; they are open when the relay is energized or the

switch is activated. In ladder programming, a symbol that allows logic continuity (flow) if the referenced input is logic “0” when evaluated.

normally open

Contacts on a relay or switch that are open when the relay is de-energized or the switch is deactivated. (They are closed when the relay is energized or the switch is activated.) In ladder programming, a symbol that allows logic continuity (flow) if the referenced input is logic “1” when evaluated.

off-delay time

The OFF delay time is a measure of the time required for the controller logic to recognize that a signal has been removed from the input terminal of the controller. The time is determined by circuit component delays and by any filter adjustment applied.

offline

Describes devices not under direct communication.

offset

The steady-state deviation of a controlled variable from a fixed point.

off-state leakage current

When an ideal mechanical switch is opened (off-state) no current flows through the switch. Practical semiconductor switches, and the transient suppression components which are sometimes used to protect switches, allow a small current to flow when the switch is in the off state. This current is referred to as the off-state leakage current. To ensure reliable operation, the off-state leakage current rating of a switch should be less than the minimum operating current rating of the load that is connected to the switch.

on-delay time

The ON delay time is a measure of the time required for the controller logic to recognize that a signal has been presented at the input terminal of the controller.

one-shot

A programming technique that sets a bit for only one program scan.

online

Describes devices under direct communication. For example, when RSLogix 500 is monitoring the program file in a controller.

operating voltage

For inputs, the voltage range needed for the input to be in the On state. For outputs, the allowable range of user-supplied voltage.

output device

A device, such as a pilot light or a motor starter coil, that is controlled by the controller.

processor

A Central Processing Unit. (See CPU.)

processor file

The set of program and data files used by the controller to control output devices. Only one processor file may be stored in the controller at a time.

program file

The area within a processor file that contains the ladder logic program.

program mode

When the controller is not executing the processor file and all outputs are de-energized.

program scan

A part of the controller's operating cycle. During the scan the ladder program is executed and the output data file is updated based on the program and the input data file.

programming device

Executable programming package used to develop ladder diagrams.

protocol

The packaging of information that is transmitted across a network.

read

To acquire data from a storage place. For example, the processor READs information from the input data file to solve the ladder program.

relay

An electrically operated device that mechanically switches electrical circuits.

relay logic

A representation of the program or other logic in a form normally used for relays.

restore

To download (transfer) a program from a personal computer to a controller.

reserved bit

A status file location that the user should not read or write to.

retentive data

Information associated with data files (timers, counters, inputs, and outputs) in a program that is preserved through power cycles.

RS-232

An EIA standard that specifies electrical, mechanical, and functional characteristics for serial binary communication circuits. A single-ended serial communication interface.

run mode

This is an executing mode during which the controller scans or executes the ladder program, monitors input devices, energizes output devices, and acts on enabled I/O forces.

rung

Ladder logic is comprised of a set of rungs. A rung contains input and output instructions. During Run mode, the inputs on a rung are evaluated to be true or false. If a path of true logic exists, the outputs are made true. If all paths are false, the outputs are made false.

save

To upload (transfer) a program stored in memory from a controller to a personal computer; OR to save a program to a computer hard disk.

scan time

The time required for the controller to execute the instructions in the program. The scan time may vary depending on the instructions and each instruction's status during the scan.

sinking

A term used to describe current flow between an I/O device and controller I/O circuit — typically, a sinking device or circuit provides a path to ground, low, or negative side of power supply.

sourcing

A term used to describe current flow between an I/O device and controller I/O circuit — typically, a sourcing device or circuit provides a path to the source, high, or positive side of power supply.

status

The condition of a circuit or system, represented as logic 0 (OFF) or 1 (ON).

terminal

A point on an I/O module that external I/O devices, such as a push button or pilot light, are wired to.

throughput

The time between when an input turns on and the corresponding output turns on.

true

The status of an instruction that provides a continuous logical path on a ladder rung.

upload

Data is transferred to a programming or storage device from another device.

watchdog timer

A timer that monitors a cyclical process and is cleared at the conclusion of each cycle. If the watchdog runs past its programmed time period, it causes a fault.

workspace

The main storage available for programs and data and allocated for working storage.

write

To copy data to a storage device. For example, the processor WRITES the information from the output data file to the output modules.

Notes:

Numerics

1762-24AWA wiring diagram 3-50

1762-IA8 wiring diagram 3-56

1762-IF20F2

input type selection 3-64

output type selection 3-64

terminal block layout 3-65

wiring 3-65

1762-IF4

input type selection 3-66

terminal block layout 3-67

1762-IQ16 wiring diagram 3-57

1762-IQ32T wiring diagram 3-58

1762-IQ8 wiring diagram 3-56

1762-OA8 wiring diagram 3-58

1762-OB16 wiring diagram 3-59

1762-OB32T wiring diagram 3-60

1762-OB8 wiring diagram 3-59

1762-OV32T wiring diagram 3-60

1762-OW16 wiring diagram 3-61

1762-OW8 wiring diagram 3-61

1762-OX6I wiring diagram 3-62

5/05 processors

Ethernet communications F-217

A

address G-241

Advanced Interface Converter. See AIC+

agency certifications 2-19

AIC+

applying power to 4-95

attaching to the network 4-94

connecting 4-89

definition G-241

installing 4-94

recommended user supplied components 4-93

safety consideration 4-94

selecting cable 4-91

analog channel wiring guidelines 3-53

analog expansion I/O C-190

diagnostics C-190

module operation vs. channel operation C-190

power-up diagnostics C-190

system wiring guidelines 3-63

troubleshooting C-190

analog inputs

analog channel wiring guidelines 3-53

application G-241

B

battery 6-140

processor battery life expectancy B-180

processor replacement battery B-180

baud rate G-241

bit G-241

block diagrams G-241

Boolean operators G-241

BOOTP

configuring SLC 5/05 F-226–F-230

using the Rockwell Utility F-228

branch G-241

Buttons 5-104

C

cable pinout

MicroLogix 1100 Channel 0 to modem cable 4-79, 4-88

cables

planning routes for DH485 connections E-211

selection guide for the AIC+ 4-91

calling for assistance C-194

CE mark 2-19, 2-20

common mode rejection ratio

specification A-175

common techniques used in this manual P-10

communication

DeviceNet 4-97

Ethernet 4-97

communication connections 4-71

communication options 1-16

communication protocols

DF1 Full-Duplex E-203

DF1 Half-Duplex E-205

DH485 E-209

Ethernet F-217

Modbus E-216

communication scan G-241

communications toggle push button

using 4-72

component descriptions 1-12

1762 expansion I/O 1-13

communication cables 1-14

memory module 1-12

real-time clock 1-12

configuration errors C-192

connecting expansion I/O 2-39

connecting the system

AIC+ 4-89, 4-94

DeviceNet network 4-97

DF1 Full-Duplex protocol 4-76

DF1 isolated point-to-point connection 4-77

DH485 network 4-83

connecting to DF1 Half-Duplex network 4-80
contactors (bulletin 100), surge suppressors for 3-45

control profile G-242

ControlFlash

missing/corrupt OS LED pattern D-201
 sequence of operation D-200
 using D-195

controller G-242

grounding 3-46
 I/O wiring 3-53
 installation 2-19
 LED status error conditions C-188
 LED status normal operation C-188
 minimizing electrical noise 3-53
 mounting 2-34
 mounting dimensions 2-33
 mounting on DIN rail 2-35
 mounting on panel 2-36
 preventing excessive heat 2-25
 status indicators C-185

controller overhead G-242

controller spacing 2-33

counter G-242

CPU (Central Processing Unit) G-242

Cursor display 5-105

D

data table G-242

default communication configuration 4-72

DeviceNet Communications 4-97

DeviceNet network

connecting 4-97

DF1 Full-Duplex protocol

connecting 4-76, 4-77
 description E-203
 example system configuration E-204
 using a modem 4-78, E-207

DF1 Half-Duplex protocol

description E-205

DH485 communication protocol

configuration parameters 4-83, E-209

DH485 network

configuration parameters E-212
 connecting 4-83
 devices that use the network E-210
 example system configuration E-214
 installation 4-85
 planning considerations E-210

DIN rail G-242

disconnecting main power 2-23

download G-242

DTE (Data Terminal Equipment) G-242

E

Electronics Industries Association (EIA) E-203

EMC Directive 2-20

EMI G-243

encoder G-243

error recovery model C-189

errors

configuration C-192
 critical C-191
 extended error information field C-192
 hardware C-192
 module error field C-192
 non-critical C-191

Ethernet

advanced functions F-230
 messaging F-218
 processor performance F-218
 using the SLC 5/05 processors F-217

European Union Directive compliance 2-19

EMC Directive 2-20

low voltage directive 2-20

executing mode G-243

expansion I/O

1762-IF20F2 input type selection 3-64
 1762-IF20F2 output type selection 3-64

expansion I/O mounting 2-37, 2-38

mounting on DIN rail 2-37

expansion I/O wiring 3-56

1762-IA8 wiring diagram 3-56
 1762-IF20F2 wiring 3-65
 1762-IF4 terminal block layout 3-67
 1762-IQ16 wiring diagram 3-57
 1762-IQ32T wiring diagram 3-58
 1762-IQ8 wiring diagram 3-56
 1762-OA8 wiring diagram 3-58
 1762-OB16 wiring diagram 3-59
 1762-OB32T wiring diagram 3-60
 1762-OB8 wiring diagram 3-59
 1762-OV32T wiring diagram 3-60
 1762-OW16 wiring diagram 3-61
 1762-OW8 wiring diagram 3-61
 1762-OX6I wiring diagram 3-62
 analog wiring guidelines 3-63

extended error information field C-192

F

false G-243
FIFO (First-In-First-Out) G-243
file G-243
Full-Duplex 4-77
full-duplex G-243

G

general considerations 2-20
grounding the controller 3-46

H

Half-Duplex 4-81, G-243
hard disk G-243
hardware errors C-192
hardware features 1-11
heat dissipation
 calculating G-240
heat protection 2-25
high byte G-243

I

I/O (Inputs and Outputs) G-244
input device G-244
input states on power down 2-25
inrush current G-244
installing
 ControlFlash software D-195
 memory module 2-30
 your controller 2-19
instruction G-244
instruction set G-244
isolated link coupler
 installing 4-85
isolation transformers
 power considerations 2-24

J

jump G-244

L

ladder logic G-244
least significant bit (LSB) G-244
LED (Light Emitting Diode) G-244
LIFO (Last-In-First-Out) G-244
lithium battery (1747-BA)
 disposing B-182

handling B-181
 installing B-180
 manufacturer B-182
 storing B-181
 transporting B-181

logic G-245
low byte G-245

M

manuals
 related P-10
master control relay 2-26
 emergency-stop switches 2-27
 using ANSI/CSA symbols schematic 2-29
 using IEC symbols schematic 2-28
Master Control Relay (MCR) G-245
master control relay circuit
 periodic tests 2-24
memory module
 data file protection 6-142
 operation 6-141
 program compare 6-141
 program/data/recipe backup 6-141
 removal/installation under power 6-142
 write protection 6-142
Menu structure 5-100
minimizing electrical noise 3-53
mnemonic G-245
Modbus communication protocol E-216
modem G-245
modems
 using with MicroLogix controllers E-207
modes G-245
module error field C-192
motor starters (bulletin 509)
 surge suppressors 3-45
motor starters (bulletin 709)
 surge suppressors 3-45

N

negative logic G-245
network G-245
nominal input current G-245
normally closed G-245
normally open G-246

O

offline G-246
Offline Editing 7-146
offset G-246
off-state leakage current G-246
one-shot G-246
online G-246
Online Editing 7-145
 Terms 7-146
Operating buttons 5-104
operating voltage G-247
output device G-247

P

performance
 Ethernet processor F-218
planning considerations for a network E-210
power considerations
 input states on power down 2-25
 isolation transformers 2-24
 loss of power source 2-25
 other line conditions 2-25
 overview 2-24
 power supply inrush 2-24
power distribution 2-23
power source
 loss of 2-25
power supply inrush
 power considerations 2-24
preparing for upgrade D-195
preventing excessive heat 2-25
processor G-247
processor file G-247
program file G-247
program mode G-247
program scan G-247
programming 1-16
programming device G-247
protocol G-247
publications
 related P-10
purpose of this manual P-9

R

read G-247
real-time clock
 battery operation 6-140
 operation 6-139
 removal/installation under power 6-139

writing data 6-140
related documentation P-10
related publications P-10
relay G-247
relay logic G-248
relays
 surge suppressors for 3-45
remote packet support E-213
replacement battery B-180
 disposing B-182
 handling B-181
 installing B-180
 storing B-181
 transporting B-181
replacement kits B-179
replacement parts B-179
reserved bit G-248
restore G-248
retentive data G-248
RS-232 G-248
RS-232 communication interface E-203
run mode G-248
rung G-248

S

safety circuits 2-23
safety considerations 2-21
 disconnecting main power 2-23
 hazardous location 2-21
 master control relay circuit
 periodic tests 2-24
 periodic tests of master control relay circuit 2-24
 power distribution 2-23
 safety circuits 2-23
save G-248
scan time G-248
sinking G-249
sinking and sourcing wiring diagrams 3-50
sinking wiring diagram
 1762-24BWA 3-50
sourcing G-249
sourcing wiring diagram
 1762-24BWA 3-51, 3-52
specifications A-153
status G-249
surge suppressors
 for contactor 3-45
 for motor starters 3-45
 for relays 3-45
 recommended 3-45

using 3-43

system configuration

DF1 Full-Duplex examples E-204
DH485 connection examples E-214

system loading

example calculations G-236
limitations G-235
worksheet G-238

system loading and heat dissipation G-235

T

terminal G-249

terminal block layouts

1762-IF20F2 3-65
1762-IF4 3-67
controllers 3-47
terminal groupings 3-49

terminal groupings 3-49

throughput G-249

Trim Pot Information Function File 5-133

trim pot operation 5-133

trim pots 5-133

changing values 5-133
error conditions 5-135
location 5-133

troubleshooting C-185

true G-249

U

upload G-249

using communications toggle functionality 4-72

using communications toggle push button 4-72

using emergency-stop switches 2-27

using memory modules 6-139

using real-time clock 6-139

using trim pots 5-133

W

wiring diagram

1762-IA8 3-56
1762-IF20F2 differential sensor 3-65
1762-IF20F2 single-ended sensor 3-66
1762-IQ16 3-57
1762-IQ32T 3-58
1762-IQ8 3-56
1762-L24BXB output 3-52
1762-OA8 3-58
1762-OB16 3-59
1762-OB32T 3-60

1762-OB8 3-59

1762-OV32T 3-60

1762-OW16 3-61

1762-OW8 3-61

1762-OX6I 3-62

1763-L16AWAE input 3-50

1763-L16AWAE output 3-52

1763-L16BBBE sinking 3-51

1763-L16BBBE sourcing 3-51

1763-L16BWAE output 3-52

1763-L16BWAE sinking 3-51

1763-L16BWAE sourcing 3-51

terminal block layouts 3-47, 3-65, 3-67

wiring diagrams 3-47

wiring recommendation 3-41

wiring your controller 3-41

workspace G-249

write G-249

Notes:

Rockwell Automation Support

Rockwell Automation provides technical information on the Web to assist you in using its products.

At <http://www.rockwellautomation.com/support/>, you can find technical manuals, a knowledge base of FAQs, technical and application notes, sample code and links to software service packs, and a MySupport feature that you can customize to make the best use of these tools.

For an additional level of technical phone support for installation, configuration, and troubleshooting, we offer TechConnect support programs. For more information, contact your local distributor or Rockwell Automation representative, or visit <http://www.rockwellautomation.com/support/>.

Installation Assistance

If you experience a problem within the first 24 hours of installation, review the information that is contained in this manual. You can contact Customer Support for initial help in getting your product up and running.

United States or Canada	1.440.646.3434
Outside United States or Canada	Use the Worldwide Locator at http://www.rockwellautomation.com/support/americas/phone_en.html , or contact your local Rockwell Automation representative.

New Product Satisfaction Return

Rockwell Automation tests all of its products to ensure that they are fully operational when shipped from the manufacturing facility. However, if your product is not functioning and needs to be returned, follow these procedures.

United States	Contact your distributor. You must provide a Customer Support case number (call the phone number above to obtain one) to your distributor to complete the return process.
Outside United States	Please contact your local Rockwell Automation representative for the return procedure.

Documentation Feedback

Your comments will help us serve your documentation needs better. If you have any suggestions on how to improve this document, complete this form, publication [RA-DU002](#), available at <http://www.rockwellautomation.com/literature/>.

Rockwell Otomasyon Ticaret A.Ş., Kar Plaza İş Merkezi E Blok Kat:6 34752 İçerenköy, İstanbul, Tel: +90 (216) 5698400

www.rockwellautomation.com

Power, Control and Information Solutions Headquarters

Americas: Rockwell Automation, 1201 South Second Street, Milwaukee, WI 53204-2496 USA, Tel: (1) 414.382.2000, Fax: (1) 414.382.4444

Europe/Middle East/Africa: Rockwell Automation NV, Pegasus Park, De Kleetlaan 12a, 1831 Diegem, Belgium, Tel: (32) 2 663 0600, Fax: (32) 2 663 0640

Asia Pacific: Rockwell Automation, Level 14, Core F, Cyberport 3, 100 Cyberport Road, Hong Kong, Tel: (852) 2887 4788, Fax: (852) 2508 1846

Publication 1763-UM001F-EN-P - April 2017

Supersedes Publication 1763-UM001E-EN-P - June 2015

Copyright © 2017 Rockwell Automation, Inc. All rights reserved.