

Electro-Pneumatic Positioner TZIDC, TZIDC-110, TZIDC-120

For 4 ... 20 mA two-wire technology,
HART, PROFIBUS PA,
FOUNDATION fieldbus



Electro-Pneumatic Positioner TZIDC, TZIDC-110, TZIDC-120

Operating Instruction

42/18-84-EN

04.2016

Rev. E

Translation of the original instruction

Manufacturer:

**ABB Automation Products GmbH
Process Automation**

Schillerstraße 72

32425 Minden

Germany

Tel.: +49 571 830-0

Fax: +49 571 830-1806

Customer service center

Phone: +49 180 5 222 580

automation.service@de.abb.com

© Copyright 2016 by ABB Automation Products GmbH

Subject to changes without notice

This document is protected by copyright. It assists the user in safe and efficient operation of the device. The contents of this document, whether whole or in part, may not be copied or reproduced without prior approval by the copyright holder.

1	Safety	6
1.1	General information and notes for the reader	6
1.2	Intended use.....	6
1.3	Target groups and qualifications	6
1.4	Warranty provisions.....	7
1.5	Plates and symbols	7
1.5.1	Safety- / warning symbols, note symbols.....	7
1.5.2	Name plate.....	8
1.6	Transport safety information.....	8
1.7	Storage conditions.....	8
1.8	Installation safety information.....	9
1.9	Safety information for electrical installation.....	9
1.10	Operating safety information	9
1.11	Returning devices.....	10
1.12	Integrated management system.....	10
1.13	Disposal.....	11
1.13.1	Information on WEEE Directive 2002/96/EC (Waste Electrical and Electronic Equipment).....	11
1.13.2	RoHS Directive 2002/95/EC	11
2	Ex relevant safety instructions	12
3	Design and function	13
4	Mounting	14
4.1	Operating conditions at installation site.....	14
4.2	Mechanical mount	14
4.2.1	General information.....	14
4.2.2	Mounting on linear actuators.....	16
4.2.3	Mounting on rotary actuators	20
5	Electrical connections	23
5.1	Screw terminal assignments	25
5.2	Jumper configuration on mainboard (TZIDC-120 only).....	26
5.3	Cable entry	27
5.4	Setting the mechanical feedback	27
5.4.1	Mechanical position indicator.....	27
5.4.2	Mechanical digital feedback with proximity switches	28
5.4.3	Mechanical feedback with micro switches for 24 V	28
5.5	"TZIDC with remote position sensor"	29
5.5.1	Electrical connection of TZIDC with remote position sensor	30
5.6	"TZIDC for remote position sensor"	31
5.6.1	Electrical connection of TZIDC for remote position sensor.....	32
6	Pneumatic connection	33
7	Commissioning	35
7.1	TZIDC.....	35
7.1.1	Operating modes.....	36
7.1.2	Sample parameters.....	37
7.2	TZIDC-110 / TZIDC-120.....	39
7.2.1	Operating modes.....	40
7.2.2	Sample parameters.....	41
8	Maintenance	42
8.1	Functional check for emergency shutdown module.....	43

Contents

9	Specifications	44
9.1	TZIDC	44
9.1.1	Input	44
9.1.2	Output	44
9.1.3	Travel	44
9.1.4	Air supply	44
9.1.5	Transmission data and influences	45
9.1.6	Environmental capabilities	45
9.1.7	Housing	45
9.1.8	Safety Integrity Level	45
9.1.9	Options	46
9.1.10	Accessories	47
9.2	TZIDC-110	47
9.2.1	Communication	47
9.2.2	Device name	47
9.2.3	Output	47
9.2.4	Travel	47
9.2.5	Air supply	47
9.2.6	Transmission data and influences	48
9.2.7	Environmental capabilities	48
9.2.8	Housing	48
9.2.9	Options	48
9.2.10	Accessories	49
9.3	TZIDC-120	49
9.3.1	Communication	49
9.3.2	Device name	50
9.3.3	Output	50
9.3.4	Travel	50
9.3.5	Air supply	50
9.3.6	Transmission data and influences	50
9.3.7	Environmental capabilities	50
9.3.8	Housing	51
9.3.9	Options	51
9.3.10	Accessories	51
10	Ex relevant specifications	52
10.1	TZIDC	52
10.1.1	ATEX Ex i	52
10.1.2	ATEX Ex n	55
10.1.3	IECEX	56
10.1.4	IECEX i	57
10.1.5	IECEX n	58
10.1.6	CSA International	59
10.1.7	CSA Certification Record	61
10.1.8	FM Approvals	62
10.1.9	FM Control Document	63
10.2	TZIDC-110	67
10.2.1	ATEX Ex i	67
10.2.2	ATEX Ex n	68

10.2.3	IECEEx	69
10.2.4	IECEEx i	69
10.2.5	IECEEx n	70
10.2.6	CSA International	71
10.2.7	CSA Certification Record	72
10.2.8	FM Approvals	73
10.2.9	FM Control Document	74
10.3	TZIDC-120	77
10.3.1	ATEX Ex i	77
10.3.2	ATEX Ex n	78
10.3.3	IECEEx	79
10.3.4	IECEEx i	79
10.3.5	IECEEx n	80
10.3.6	CSA International	81
10.3.7	CSA Certification Record	82
10.3.8	FM Approvals	83
10.3.9	FM Control Document	84
11	Parameter descriptions	87
11.1	TZIDC	87
11.1.1	Parameter overview	87
11.1.2	Parameter description	88
11.2	TZIDC-110 / TZIDC-120	90
11.2.1	Parameter overview	90
11.2.2	Parameter description	91
12	Appendix	92
12.1	Approvals and certifications	92

1 Safety

1.1 General information and notes for the reader

You must read these instructions carefully prior to installing and commissioning the device. These instructions are an important part of the product and must be kept for future reference. These instructions are intended as an overview and do not contain detailed information on all designs for this product or every possible aspect of installation, operation and maintenance. For additional information or if specific problems occur that are not discussed in these instructions, contact the manufacturer.

The content of these instructions is neither part of any previous or existing agreement, promise or legal relationship nor is it intended to change the same.

This product is built based on state-of-the-art technology and is operationally safe. It has been tested and left the factory in perfect working order from a safety perspective. The information in the manual must be observed and followed in order to maintain this state throughout the period of operation.

Modifications and repairs to the product may only be performed if expressly permitted by these instructions.

Only by observing all of the safety instructions and all safety/warning symbols in these instructions can optimum protection of both personnel and the environment, as well as safe and fault-free operation of the device, be ensured.

Information and symbols directly on the product must be observed. They may not be removed and must be fully legible at all times.

1.2 Intended use

TZIDC, TZIDC-110, TZIDC-120 positioners are electro-pneumatic positioning devices for use with pneumatically controlled actuators.

The device may only be used for the applications listed in these operating instructions and in the data sheet.

- The maximum operating temperature must not be exceeded.
- The permissible operating temperature must not be exceeded.
- The housing protection type must be observed during operation.

1.3 Target groups and qualifications

Installation, commissioning, and maintenance of the product may only be performed by trained specialist personnel who have been authorized by the plant operator to do so. The specialist personnel must have read and understood the manual and comply with its instructions.

Prior to using corrosive and abrasive materials for measurement purposes, the operator must check the level of resistance of all parts coming into contact with the materials to be measured. ABB Automation Products GmbH will gladly support you in selecting the materials, but cannot accept any liability in doing so.

The operators must strictly observe the applicable national regulations with regards to installation, function tests, repairs, and maintenance of electrical products.

1.4 Warranty provisions

Using the device in a manner that does not fall within the scope of its intended use, disregarding this instruction, using underqualified personnel, or making unauthorized alterations releases the manufacturer from liability for any resulting damage. This renders the manufacturer's warranty null and void.

1.5 Plates and symbols

1.5.1 Safety- / warning symbols, note symbols



DANGER – <Serious damage to health / risk to life>

This symbol in conjunction with the signal word "Danger" indicates an imminent danger. Failure to observe this safety information will result in death or severe injury.



DANGER – <Serious damage to health / risk to life>

This symbol in conjunction with the signal word "Danger" indicates an imminent electrical hazard. Failure to observe this safety information will result in death or severe injury.



WARNING – <Bodily injury>

This symbol in conjunction with the signal word "Warning" indicates a possibly dangerous situation. Failure to observe this safety information may result in death or severe injury.



WARNING – <Bodily injury>

This symbol in conjunction with the signal word "Warning" indicates a potential electrical hazard. Failure to observe this safety information may result in death or severe injury.



CAUTION – <Minor injury>

This symbol in conjunction with the signal word "Caution" indicates a possibly dangerous situation. Failure to observe this safety information may result in minor or moderate injury. This may also be used for property damage warnings.



NOTICE – <Property damage>!

The symbol indicates a potentially damaging situation.

Failure to observe this safety information may result in damage to or destruction of the product and/or other system components.



IMPORTANT (NOTE)

This symbol indicates operator tips, particularly useful information, or important information about the product or its further uses. It does not indicate a dangerous or damaging situation.

1.5.2 Name plate

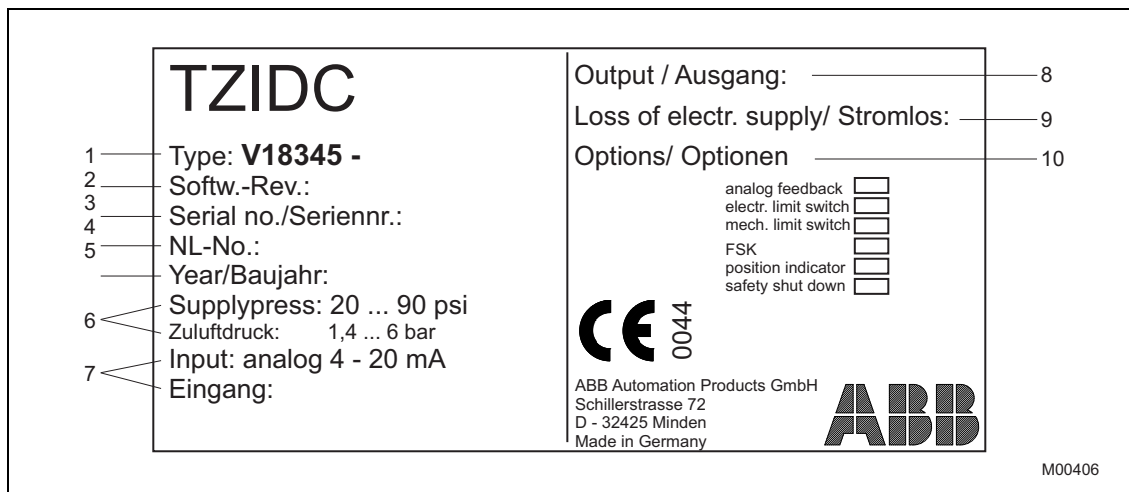

Fig. 1: Name plate

- | | |
|-----------------------|-------------------|
| 1 Complete model name | 6 Supply pressure |
| 2 Software version | 7 Input |
| 3 Serial number | 8 Output |
| 4 NL number | 9 Dead |
| 5 Year | 10 Options |

1.6 Transport safety information

Check the devices for possible damage that may have occurred during transport. Damages in transit must be recorded on the transport documents. All claims for damages must be claimed without delay against the shipper and before the installation.

1.7 Storage conditions

The unit must be stored in dry and dust-free conditions. The unit is also protected by a dessicant in the packaging.

The storage temperature should be between -40 ... 85 °C (-40 ... 185 °F).

The storage time is basically indefinite. However, the warranty conditions stipulated in the order confirmation of the supplier are valid.

1.8 Installation safety information



CAUTION - Risk of injury!

Incorrect parameter values can cause the valve to move unexpectedly. This can lead to process failures and result in injuries.

Before recommissioning a TZIDC, TZIDC-110, TZIDC-120 positioner that was used at another location, the device must always be reset to factory settings. Never start Autoadjust before restoring factory settings.

- Only qualified specialists who have been trained for these tasks are authorized to mount and adjust the unit, and to make the electrical connection.
- When working on the unit always observe the locally valid accident prevention regulations and the regulations concerning the construction of technical installations.

1.9 Safety information for electrical installation

- The electrical connection may only be made by authorized specialist personnel and in accordance with the electrical circuit diagrams.
- The electrical connection information in the manual must be observed; otherwise, the type of electrical protection may be adversely affected.
- Safe isolation of electrical circuits which are dangerous if touched is only guaranteed if the connected devices satisfy the requirements of DIN EN 61140 (VDE 0140 Part 1) (basic requirements for safe isolation).
- To ensure safe isolation, install supply lines so that they are separate from electrical circuits which are dangerous if touched, or implement additional isolation measures for them.

1.10 Operating safety information

Before switching on the unit make sure that your installation complies with the environmental conditions listed in the chapter "Technical data" or in the data sheet.

If there is a chance that safe operation is no longer possible, take the unit out of operation and secure against unintended startup.

When mounting the unit in areas that may be accessed by unauthorized persons, take the required protective measures.

Prior to installation, check the devices for any damage that may have occurred as a result of improper transport. Details of any damage that has occurred in transit must be recorded on the transport documents. All claims for damages must be submitted to the shipper without delay and before installation.

1.11 Returning devices

Use the original packaging or suitably secure shipping containers if you need to return the device for repair or recalibration purposes. Fill out the return form (see the Appendix) and include this with the device.

According to EC guidelines for hazardous materials, the owner of hazardous waste is responsible for its disposal or must observe the following regulations for shipping purposes:

All devices delivered to ABB Automation Products GmbH must be free from any hazardous materials (acids, alkalis, solvents, etc.).

Please contact Customer Center Service acc. to page 2 for nearest service location.

1.12 Integrated management system

ABB Automation Products GmbH operates an integrated management system, consisting of:

- Quality management system to ISO 9001:2008
- Environmental management system to ISO 14001:2004
- Occupational health and safety management system to BS OHSAS 18001:2007 and
- Data and information protection management system

Environmental awareness is an important part of our company policy.

Our products and solutions are intended to have a minimal impact on the environment and on people during manufacturing, storage, transport, use, and disposal.

This includes the environmentally-friendly use of natural resources. We conduct an open dialog with the public through our publications.

1.13 Disposal

This product is manufactured from materials that can be reused by specialist recycling companies.

1.13.1 Information on WEEE Directive 2002/96/EC (Waste Electrical and Electronic Equipment)

This product is not subject to WEEE Directive 2002/96/EC or relevant national laws (e.g., ElektroG in Germany).

The product must be disposed of at a specialist recycling facility. Do not use municipal garbage collection points. According to the WEEE Directive 2002/96/EC, only products used in private applications may be disposed of at municipal garbage facilities. Proper disposal prevents negative effects on people and the environment, and supports the reuse of valuable raw materials.

If it is not possible to dispose of old equipment properly, ABB Service can accept and dispose of returns for a fee.

1.13.2 RoHS Directive 2002/95/EC

With the Electrical and Electronic Equipment Act (ElektroG) in Germany, the European Directives 2002/96/EC (WEEE) and 2002/95/EC (RoHS) are translated into national law. ElektroG defines the products that are subject to regulated collection and disposal or reuse in the event of disposal or at the end of their service life. ElektroG also prohibits the marketing of electrical and electronic equipment that contains certain amounts of lead, cadmium, mercury, hexavalent chromium, polybrominated biphenyls (PBB), and polybrominated diphenyl ethers (PBDE) (also known as hazardous substances with restricted uses).

The products provided by ABB Automation Products GmbH do not fall within the current scope of the directive on waste from electrical and electronic equipment according to ElektroG. If the necessary components are available on the market at the right time, in the future these substances will no longer be used in new product development.

2 Ex relevant safety instructions

Depending on the type of explosion protection, an Ex label is attached to the left of the positioner beside the main name plate. It indicates the level of explosion protection and the device's relevant Ex certificate.

Requirements / preconditions for safe operation of the positioner:



IMPORTANT (NOTE)

Observe the device's applicable technical data and special conditions in accordance with the relevant certificate.

- Manipulation of the device by users is not permitted. Modifications to the unit may only be performed by the manufacturer or an explosion protection specialist.
- The splash guard cap must be screwed in place to achieve IP 65 / NEMA 4x protection class. Operating the unit without splash guard cap is prohibited.
- The device may only be supplied with instrument air that is free of oil, water, and dust. The use of flammable gas, oxygen, or oxygen-enriched gas is not permitted.
- Exception: The version of the TZIDC that is designed for operation with flammable gas, group IIA, temperature class T1 ((see IMPORTANT (NOTE) in 10 "Ex relevant specifications").

3 Design and function

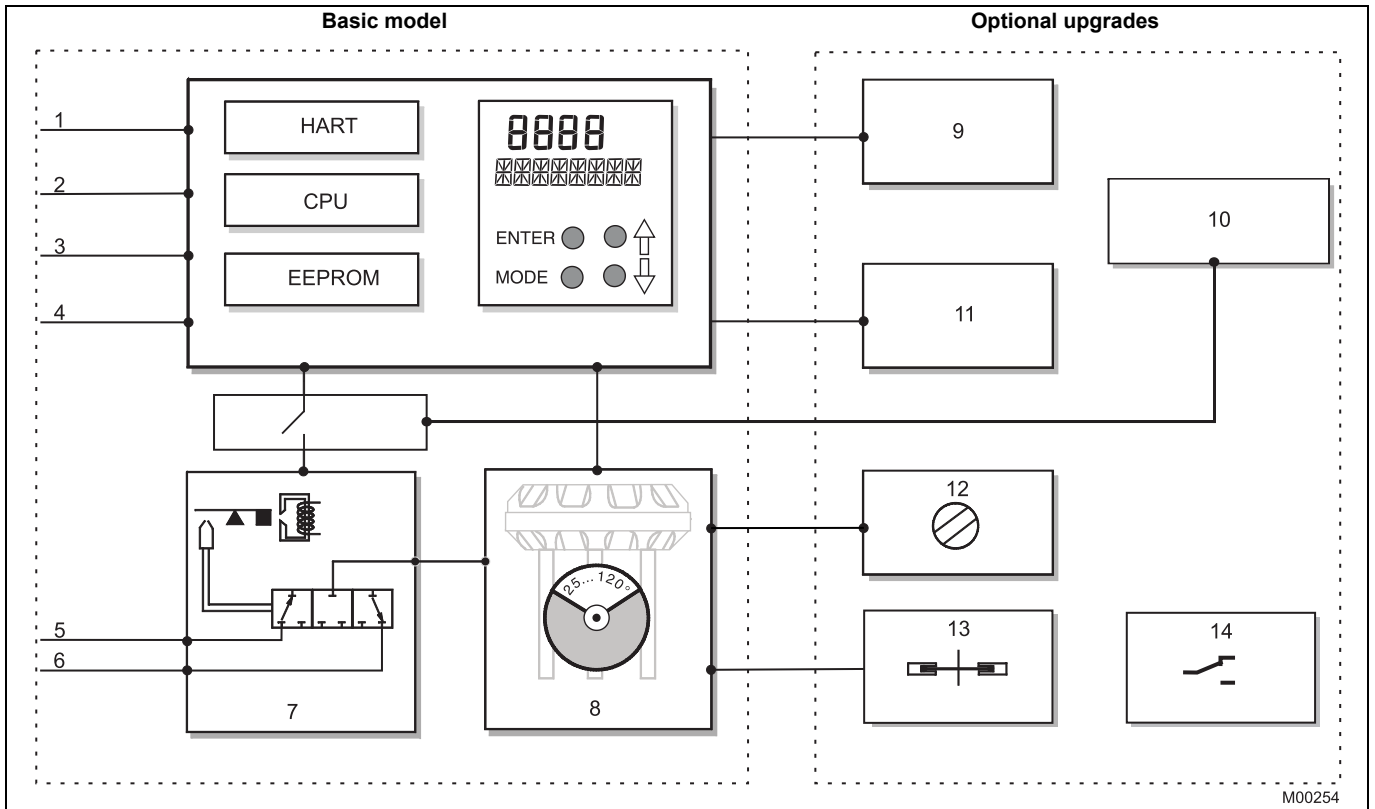

Fig. 2: TZIDC, TZIDC-110, TZIDC-120 schematic diagram

Basic model

- 1 LKS plug ¹⁾
- 2 Positioning signal 4 ... 20 mA / bus connector 9 ... 32 V DC
- 3 Digital input ¹⁾
- 4 Digital output ¹⁾
- 5 Supply air: 1.4 ... 6 bar (20 ... 90 psi)
- 6 Exhaust
- 7 I/P module with 3/3-way valve
- 8 Position sensor (optional up to 270° rotation angle)

Optional upgrades

- 9 Plug module for analog feedback (4 ... 20 mA) ¹⁾
- 10 Plug-in module for safety shutdown (forced depressurization)
- 11 Plug module for digital feedback ¹⁾
- 12 Installation kit for mechanical position indicator
- 13 Installation kit for digital feedback with proximity switches
- 14 Installation kit for digital feedback with 24 V microswitches



IMPORTANT (NOTE)

With optional upgrades either the "Installation kit for digital feedback with proximity switches" (13) or the "Installation kit for digital feedback with microswitches 24 V" (14) can be used. In both cases, the "mechanical position indicator" (8) must be installed.

¹⁾ TZIDC only

Functionality

The TZIDC, TZIDC-110, TZIDC-120 is an electronically configurable positioner with communication capabilities designed for mounting on pneumatic linear or rotary actuators.

Fully automatic determination of the control parameters and adaptation to the final control element yield considerable time savings and an optimal control behavior.

4 Mounting



CAUTION - Risk of injury!

Incorrect parameter values can cause the valve to move unexpectedly. This can lead to process failures and result in injuries.

Before recommissioning a TZIDC, TZIDC-110, TZIDC-120 positioner that was used at another location, the device must always be reset to factory settings. Never start Autoadjust before restoring factory settings.

4.1 Operating conditions at installation site



IMPORTANT (NOTE)

Before installation, check whether the TZIDC, TZIDC-110, TZIDC-120 positioner meets the control and safety requirements for the installation location (actuator or valve). See chapter Specifications page 44.

4.2 Mechanical mount

4.2.1 General information

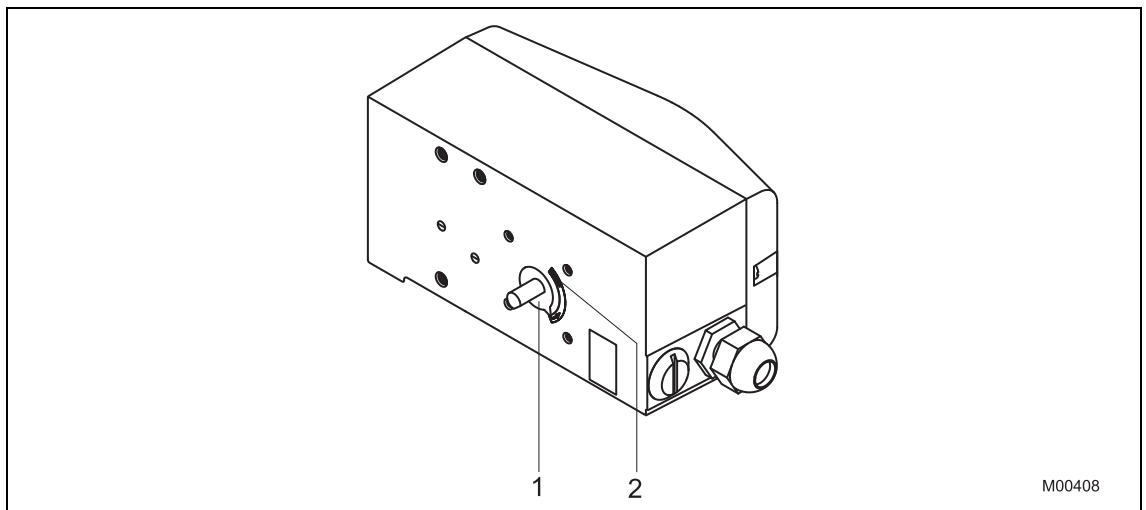

Fig. 3: Operating range

The arrow (1) on the positioner feedback shaft (and the lever) must move through the area marked by the arrows (2).

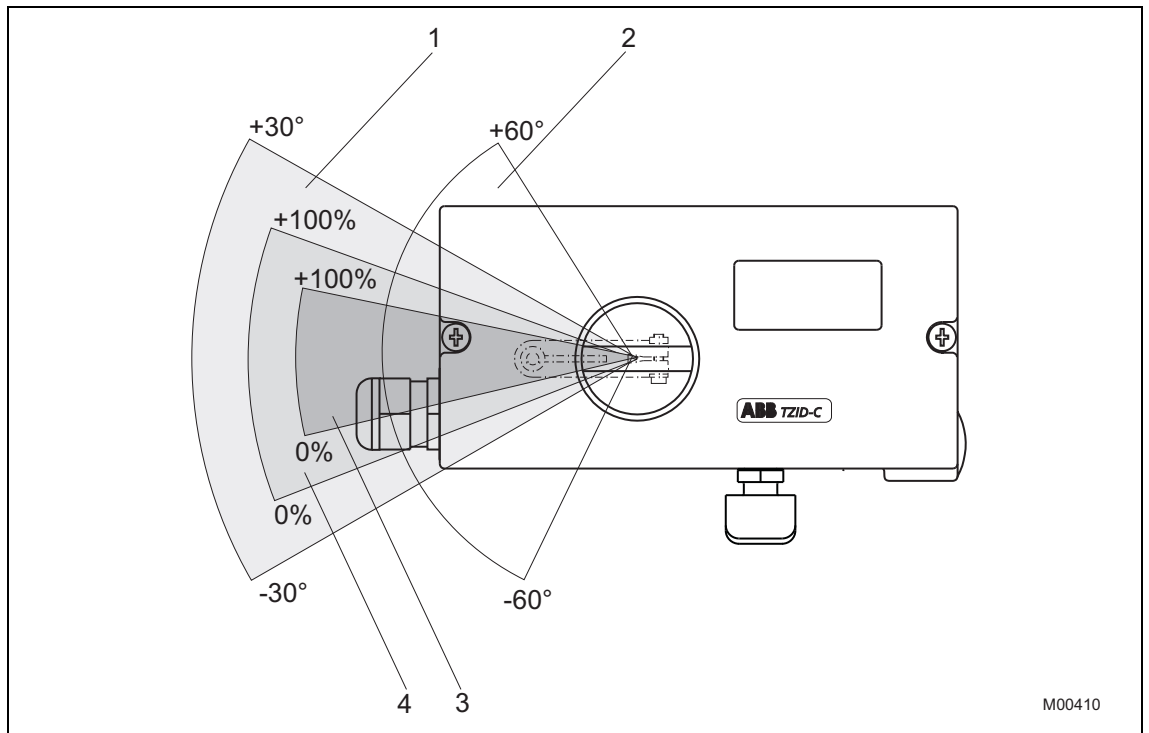

Fig. 4: Positioner range

- | | | | |
|---|--------------------------------------|---|--------------------------|
| 1 | Sensor range for linear actuators | 3 | Restricted working range |
| 2 | Sensor range for part-turn actuators | 4 | Working range |

i

IMPORTANT (NOTE)

During installation make sure that the actuator travel or rotation angle for position feedback is implemented correctly.

The maximum rotation angle for position feedback is 60° when installed on linear actuators and 120° on part-turn actuators. The minimum angle is always 25°.

4.2.2 Mounting on linear actuators

For mounting on a linear actuator in accordance with DIN / IEC 534 (lateral mount per NAMUR) a complete mounting kit is available, and consists of the items in the following table:

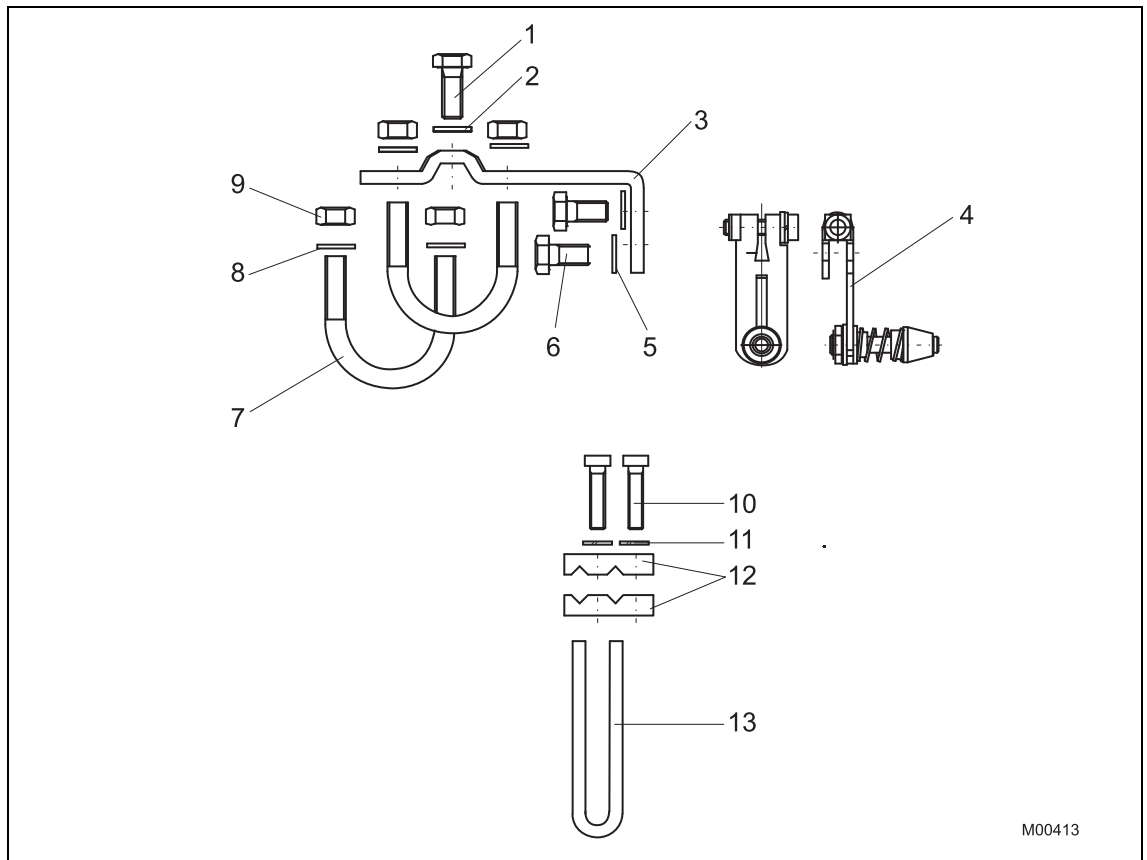

Fig. 5: Mounting kit for linear actuators

- Lever (4) with follower pin, for stroke adjustment 10 ... 35 mm (0.39 ... 1.38 inch) or 20 ... 100 mm (0.79 ... 3.94 inch)
- Follower guide (13) with two screws (10), spring washers (11) and clamp plates (12)
- Mount bracket (3) with two screws (6) and two shims (5)
- Screw (1) and shim (2) for mounting to cast iron yoke
- Two U-bolts (7) with two shims (8) and two nuts (9) for mounting to columnar yoke

Required tools:

- Wrench, size 10 / 13
- Allen key, size 4

Procedure:

1. Attach follower guide to actuator

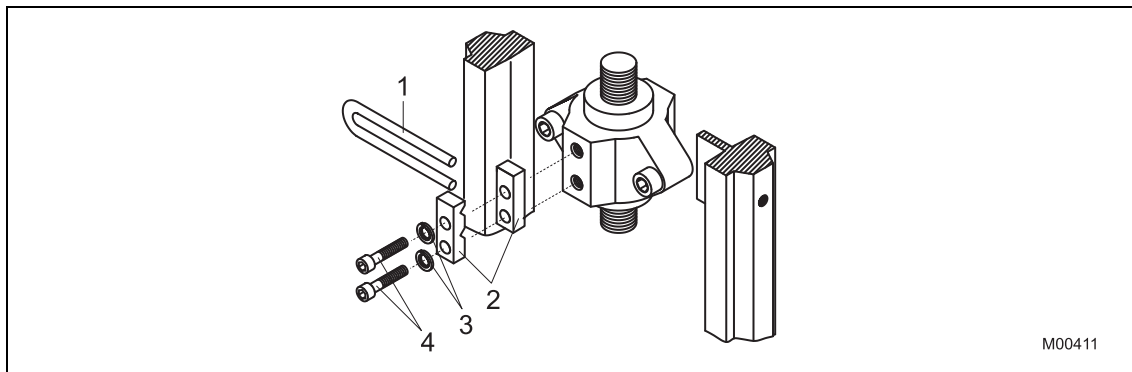

Fig. 6



IMPORTANT (NOTE)

Hand tighten the screws.

- Attach the follower guide (1) and clamp plates (2) with screws (4) and spring washers (3) to the actuator stem

2. Mount the lever and bracket on the positioner

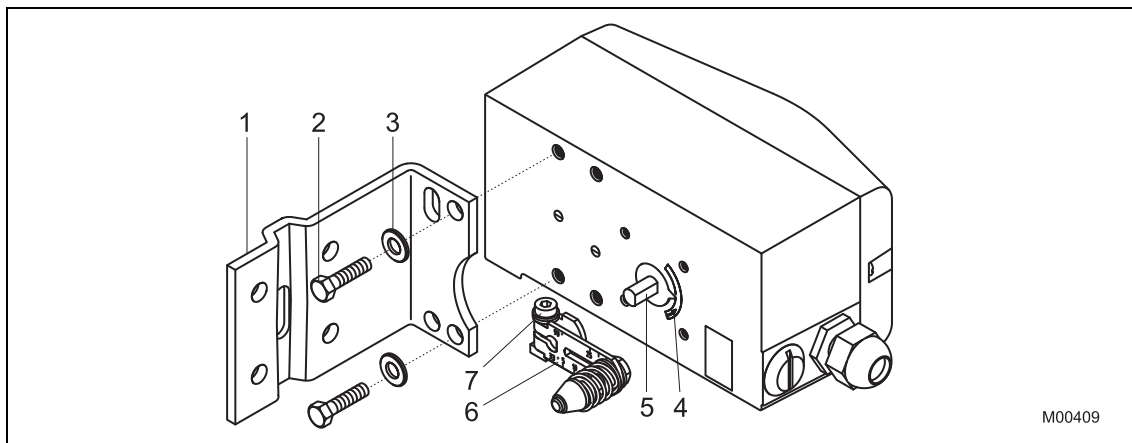

Fig. 7

- Attach the lever (6) to the feedback shaft (5) of the positioner (can only be mounted in one position due to the flat on the side of the shaft)
- Using the arrow marks (4) check whether the lever moves within the operating range (between the arrows)
- Hand-tighten the screw (7) on the lever
- Hold the prepared positioner with loose mount bracket (1) to the actuator so that the follower pin for the lever enters the follower guide to determine which holes on the positioner must be used for the mount bracket
- Attach the mount bracket (1) with screws (2) and shims (3) to the proper holes on the positioner housing. Tighten the screws as evenly as possible to ensure subsequent linearity. Align the mount bracket in the oblong hole to ensure that the operating range is symmetrical (lever moves between the arrows (4))

3.a Mounting on cast iron yoke

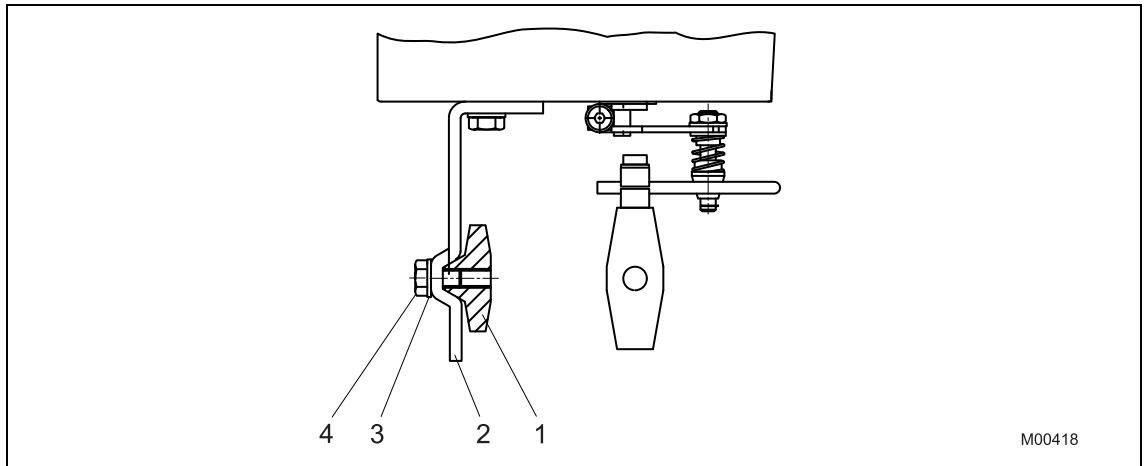

Fig. 8

- Attach the mount bracket (2) with screw (4) and shim (3) to the cast iron yoke (1)
- or

3.b Mounting on columnar yoke

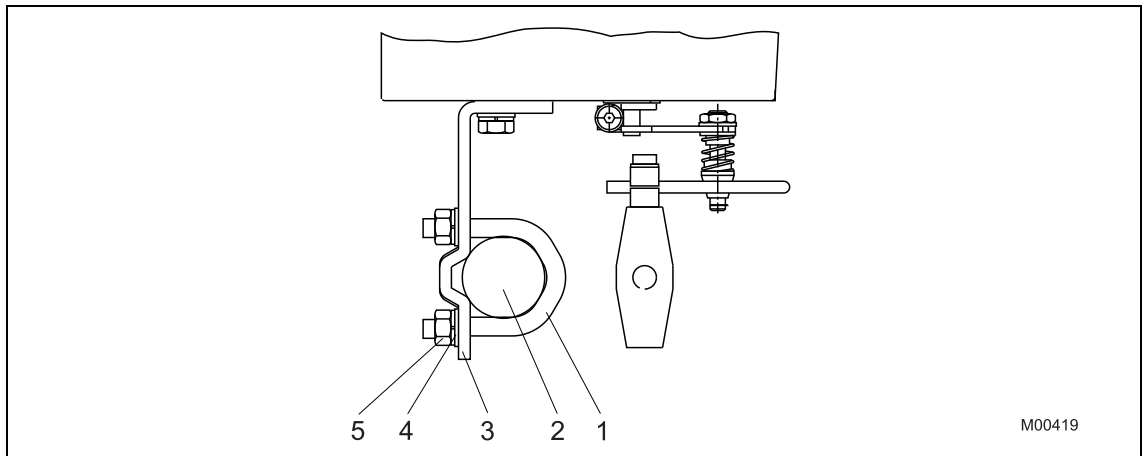

Fig. 9

- Hold the mount bracket (3) in the proper position on the columnar yoke (2)
- Insert the U-bolts (1) from the inside of the columnar yoke (2) through the holes for the mount bracket
- Add the washers (4) and nuts (5). Hand tighten the nuts



IMPORTANT (NOTE)

Adjust the height of the positioner on the cast iron yoke or columnar yoke until the lever is horizontal (based on visual check) at half stroke of the valve.

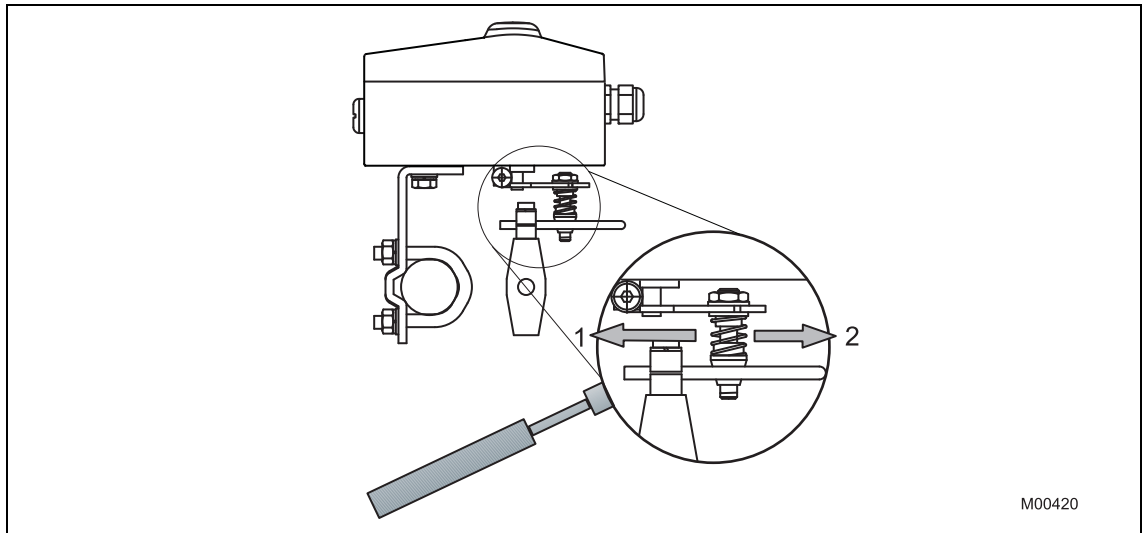

Fig. 10: Linkage for positioner

- 1 larger
- 2 smaller

The scale on the lever indicates the link point for the various stroke ranges of the valve. Move the bolt with the follower guide into the oblong hole of the lever to adjust the stroke range of the valve to the operating range for the position sensor. Moving the link point inward increases the rotation angle of the sensor. Moving the link point outward reduces the sensor's rotation angle.

Adjust the actuator stroke to make use of as large an angle of rotation as possible (symmetrical around the center position).

Recommended range for linear actuators:	between -28 ... 28°
Minimum angle:	25°



IMPORTANT (NOTE)

After mounting the unit check whether the positioner is operating within the sensor range.

4.2.3 Mounting on rotary actuators

For mounting on rotary actuators in accordance with VDI / VDE 3845, the following mounting kit is available:

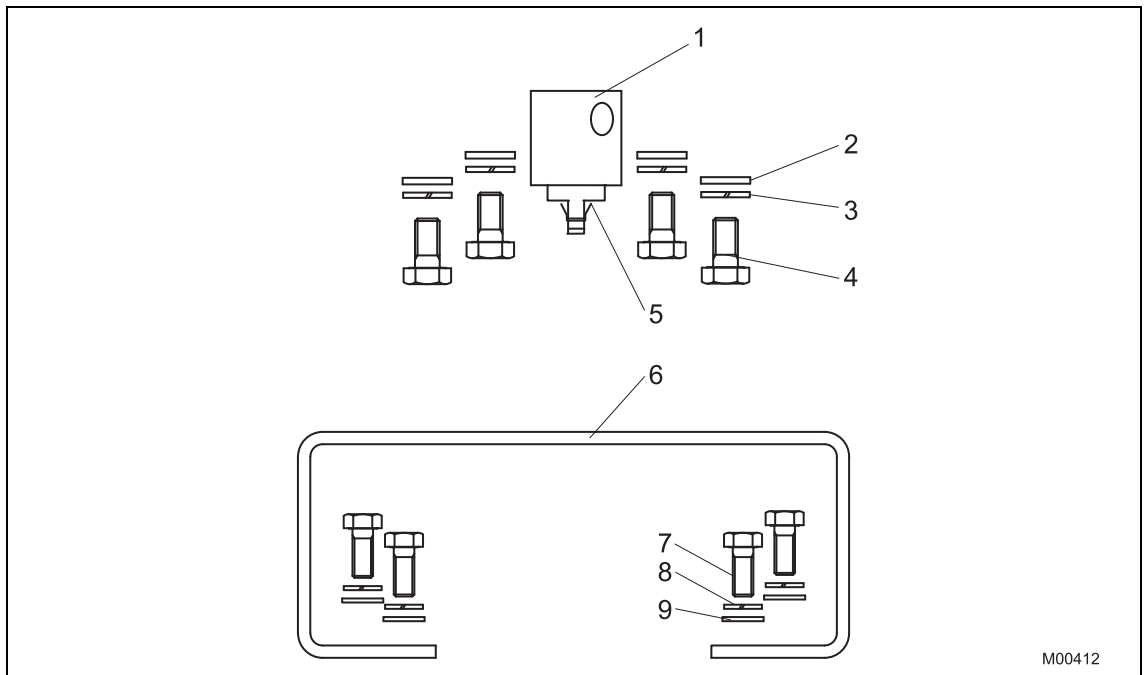

Fig. 11

- Adapter (1) with spring (5)
- each four screws M6 (4), spring washers (3) and shim (2) to attach the mounting bracket (6) on the positioner
- each four screws M5 (7), spring washers (8) and shim (9) to attach the mounting bracket on the actuator

Required tools:

- Wrench, size 10 / 13
- Allen key, size 3

Procedure:

1. Mounting the adapter on the positioner

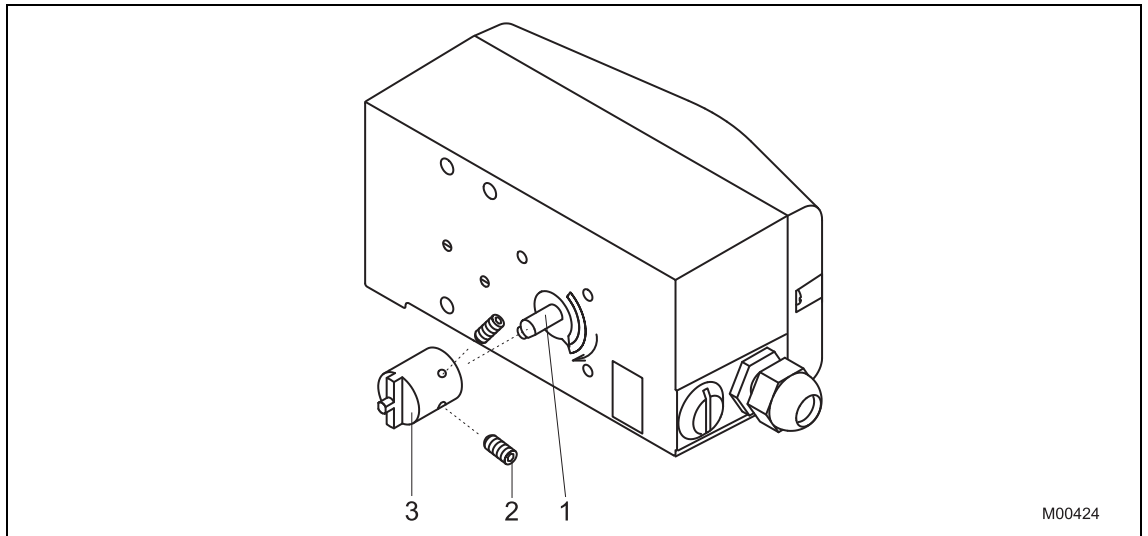

Fig. 12

- Determine the mounting position (parallel to actuator or at 90° angle)
- Calculate the rotational direction of the actuator (right or left)
- Move the rotary actuator into home position
- Based on the mounting position as well as the home position and rotational direction of the actuator, determine in which position the feedback shaft (1) for the positioner must be pre-adjusted and in which position the adapter (2) must be placed to enable the positioner to travel within the proper range (the arrow on the rear of the device must travel within the admissible range, see Fig. 3)
- Pre-adjust feedback shaft
- Place the adapter in the proper position on the feedback shaft and fasten with set screws (3). One of the set screws must be locked in place on the flat side of the feedback shaft

2. Attach mounting bracket on the positioner

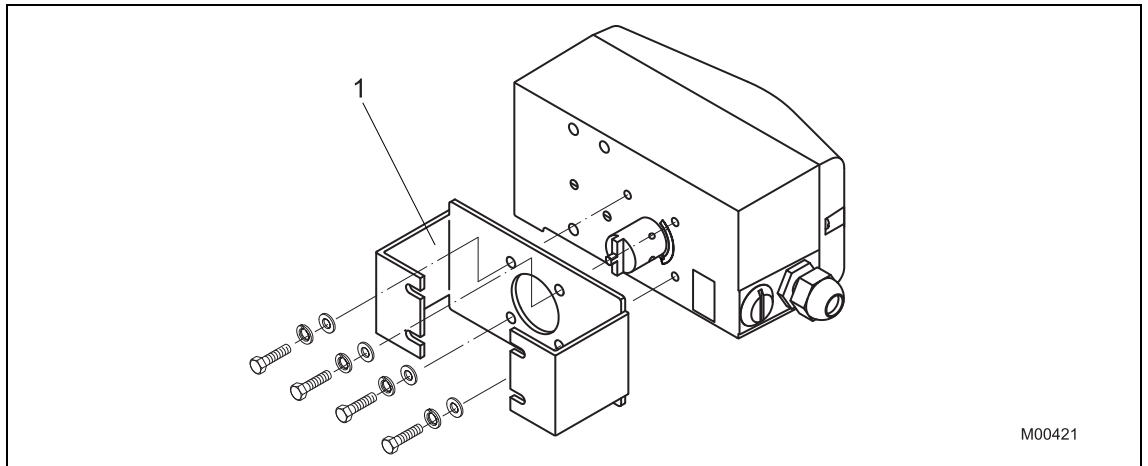

Fig. 13

1 Mounting bracket

3. Attach positioner to the actuator

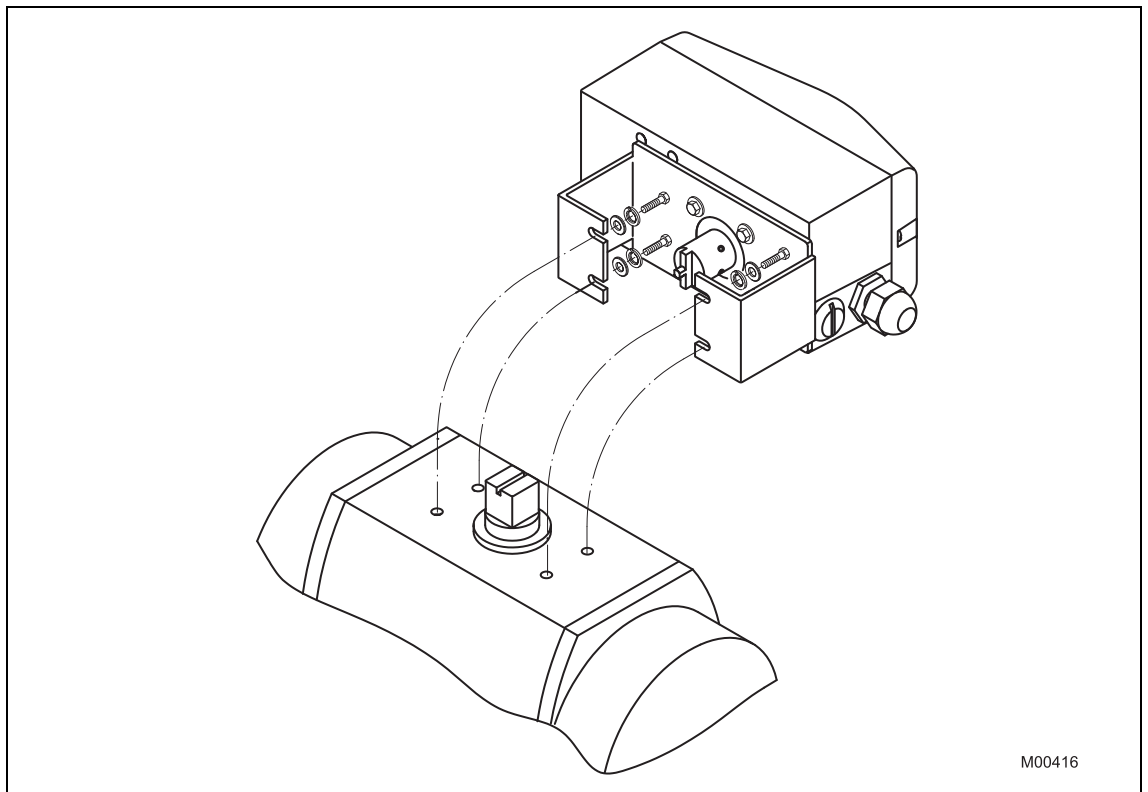

Fig. 14



IMPORTANT (NOTE)

After mounting the unit check whether the operating range for the actuator matches the sensor range on the positioner.

5 Electrical connections



DANGER! Risk of explosion! (TZIDC only)

It is prohibited to use the integrated communication interface (LKS) in an Ex area.

Never use the integrated communication interface (LKS) on the mainboard with a positioner that is being used in an explosion risk area.

1. Strip the wire by approx. 6 mm (0.24 inch).
2. To connect the signal lines, the emergency shutdown module and the proximity switches or micro switches, insert the wire ends from the left into the respective screw terminals and hand-tighten the screws (access from above). To connect a plug-in module, insert the wire ends from above in the appropriate screw terminals and hand-tighten the screws (access from the side).

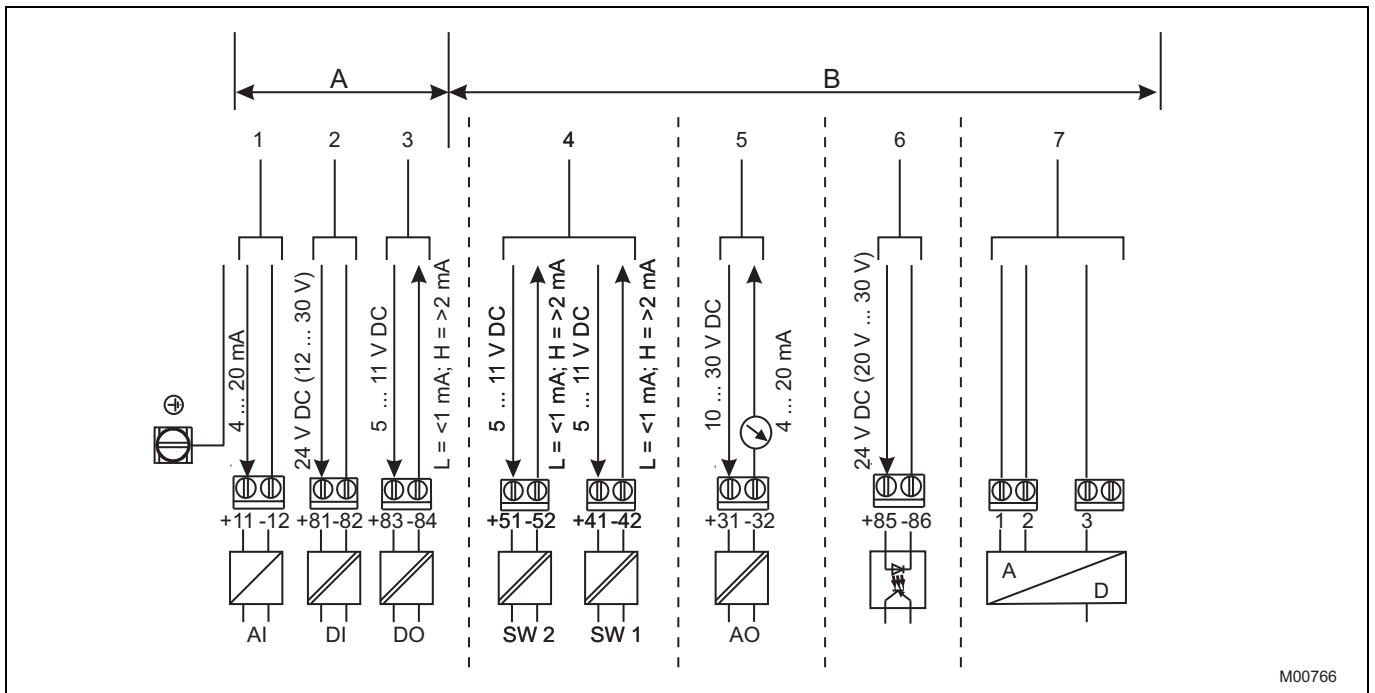

M00766

Fig. 15: Control unit connection diagram

A Basic device
B Options

- 1 Analog input/Bus connection
- 2 Binary input ¹⁾
- 3 Binary input ¹⁾
- 4 Digital feedback ¹⁾
- 5 Analog feedback ¹⁾
- 6 Emergency shutdown module
- 7 Remote sensor

1) TZIDC only

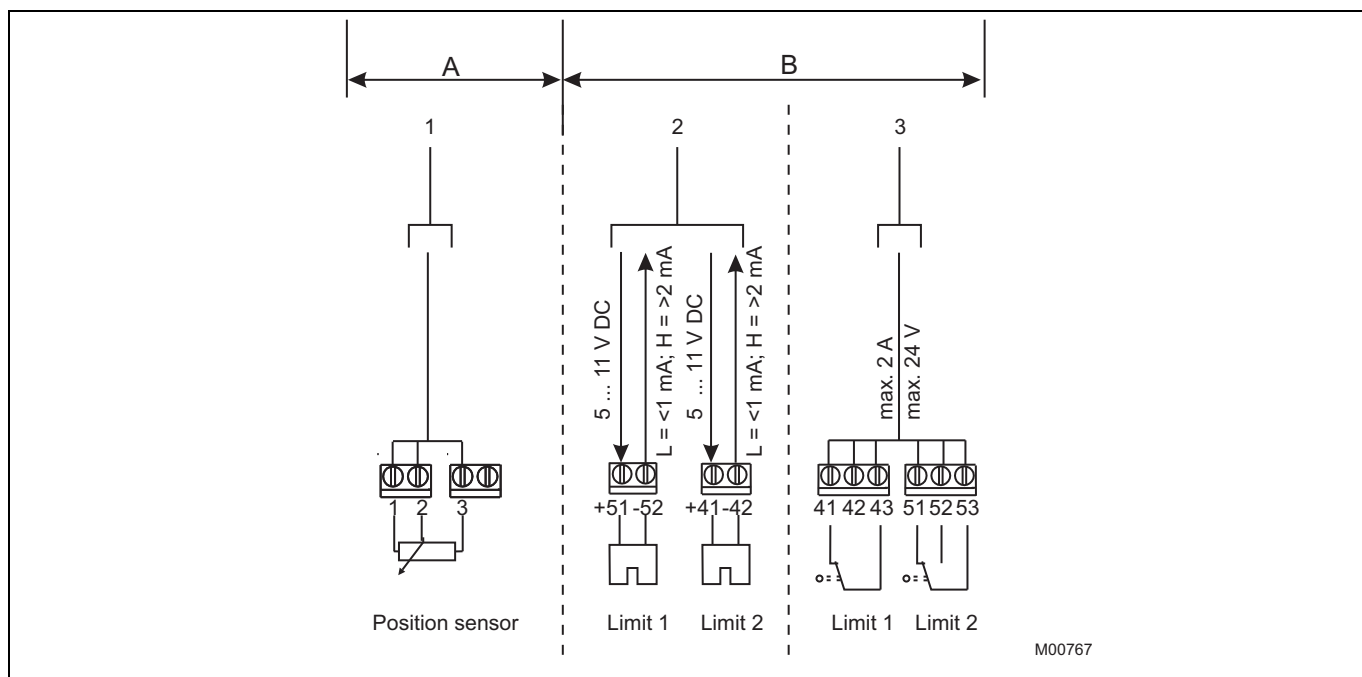

Fig. 16: Remote sensor connection diagram

A Basic device
B Options

1 Control unit
2 Proximity switches
3 Microswitches



IMPORTANT (NOTE)

Keep cable shields as short as possible and connect on both sides.

5.1 Screw terminal assignments

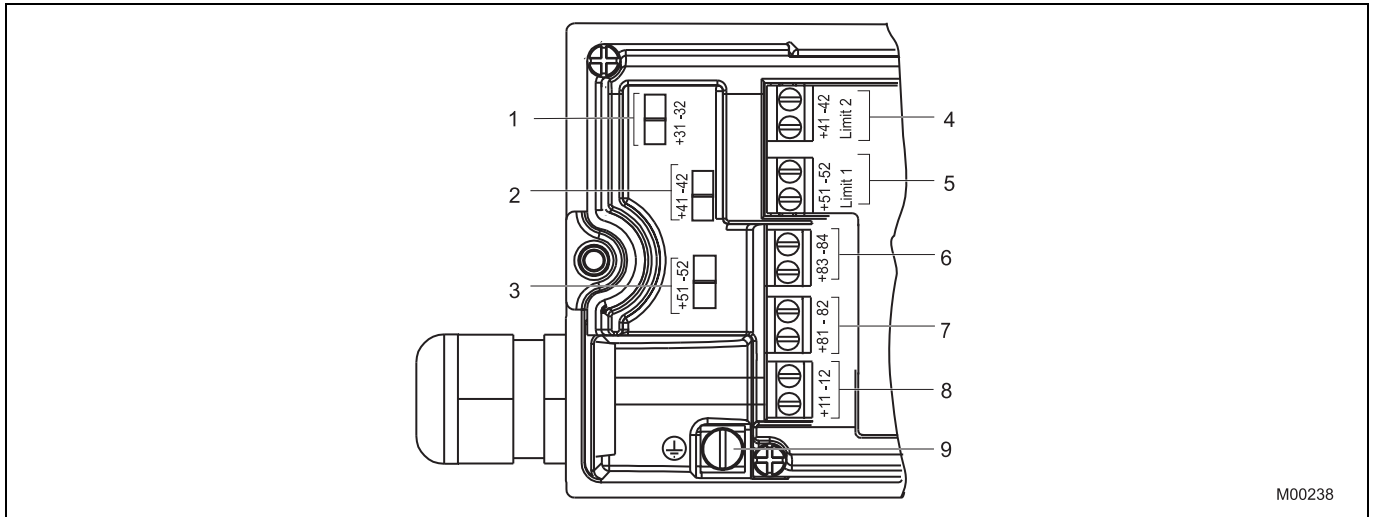

Fig. 17

- | | |
|---|--------------------------------------|
| 1 Module for analog position feedback ¹⁾ | 6 Digital output DO ¹⁾ |
| 2 Module for digital feedback ¹⁾ or service switch of emergency shutdown module | 7 Digital input DI ¹⁾ |
| 3 Module for digital position feedback ¹⁾ or terminals of the shutdown module | 8 Signal 4 ... 20 mA / Bus connector |
| 4 Installation kit for digital position feedback, either proximity switches or 24 V microswitches | 9 Grounding screw |
| 5 Same as 4 | |

1) TZIDC only

5.2 Jumper configuration on mainboard (TZIDC-120 only)

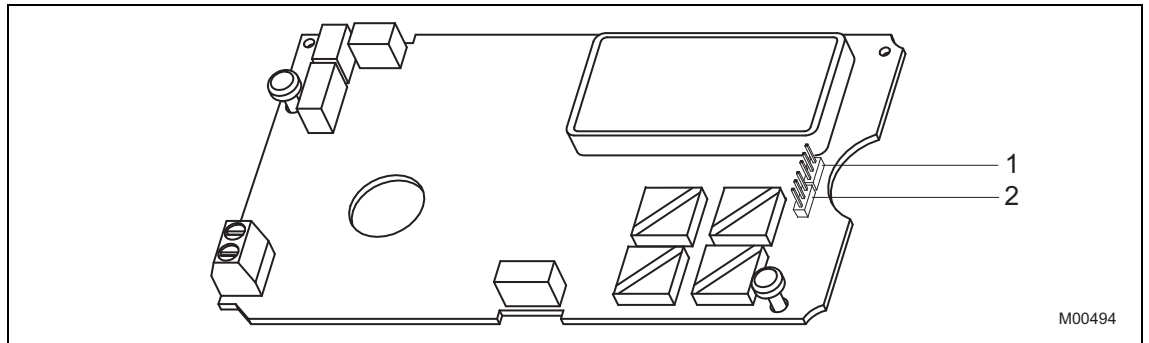

Fig. 18

- 1 Simulation
- 2 Write access

There are two jumpers on the mainboard that can be used to activate or block simulation mode and write access. Set the jumpers as shown below:

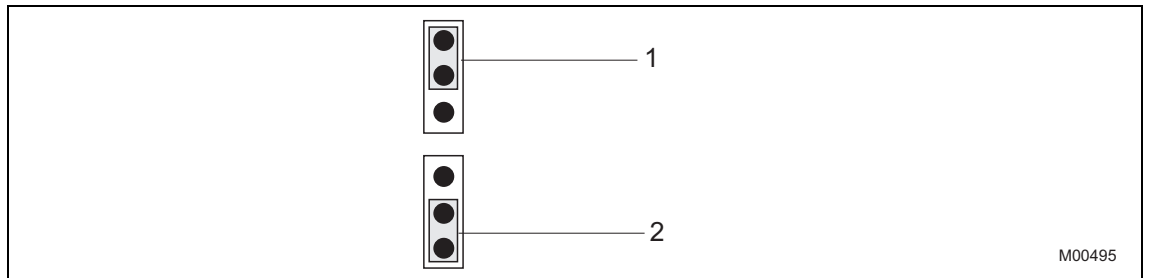

Fig. 19

- 1 Block (Simulation blocked ¹⁾)
- 2 Activate (Write access enabled ¹⁾)

1) Default setting (complies with Fieldbus Foundation standard)

5.3 Cable entry



IMPORTANT (NOTE)

The cable terminals are delivered closed and must be unscrewed before inserting the cable.

For the cable entry into the housing, on the left-hand side of the housing there are two tap holes in four thread combinations to accommodate the cable entry and pneumatic connection.

- Cable: thread 1/2-14NPT, air pipe: thread 1/4-18 NPT
- Cable: thread M20 x 1,5, air pipe: thread 1/4-18 NPT
- Cable: thread M20 x 1,5, air pipe: thread G 1/4
- Cable: thread G 1/2, air pipe: thread Rc 1/4

As an option, one thread can be fitted with a cable gland and the other with a pipe plug if necessary.

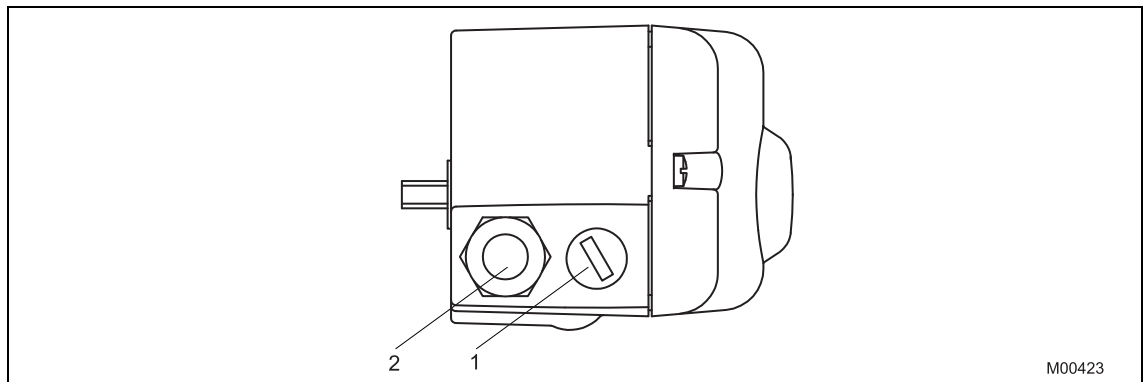

Fig. 20: Cable entry

- 1 Pipe plug
- 2 Cable gland

5.4 Setting the mechanical feedback

5.4.1 Mechanical position indicator

1. Loosen the screws for the housing cover and remove it.
2. Rotate the position indicator on the shaft to the desired position.
3. Attach the housing cover.
4. Affix the symbol label to mark the minimum and maximum valve positions on the housing cover.



IMPORTANT (NOTE)

The adhesive labels are located on the inside of the cover.

5.4.2 Mechanical digital feedback with proximity switches



1. Loosen the screws for the housing cover and remove it.

CAUTION - Risk of injury!

The device includes slot sensors with sharp edges. Use a screwdriver to adjust slot sensors.

2. Set the upper and lower switching points for digital feedback as follows:
 - Select operating mode 1.2 (see page 40) and move the valve by hand into the lower switching position.
 - Use a screwdriver to adjust the slot sensor for proximity switch 1 (lower contact) until it closes the contact (i.e. until shortly before entering the proximity switch) on the feedback shaft; the slot sensor enters proximity switch 1 when rotating to the right of the feedback shaft (viewed from the front).
 - Move the valve by hand into the upper switching position.
 - Use a screwdriver to adjust the slot sensor for proximity switch 2 (upper contact) until it closes the contact (i.e. until shortly before entering the proximity switch) on the feedback shaft; the slot sensor enters proximity switch 2 when rotating to the left of the feedback shaft (viewed from the front).
3. Attach the housing cover and screw onto housing; hand-tighten screws.

5.4.3 Mechanical feedback with micro switches for 24 V

1. Set max. contact (1, lower washer); fasten the upper washer with the special adjustment retainers and rotate lower disk manually to adjust.
2. Set min. contact (2, upper washer); fasten the lower washer with the special adjustment retainers and rotate upper disk manually to adjust.
3. Connect the micro switch.
4. Attach the housing cover and screw onto housing; hand-tighten screws.

5.5 "TZIDC with remote position sensor"

With the TZIDC designed with a remote position sensor, the components are accommodated in two housings, which together form one harmonized unit.

Housing 1 (control unit) contains the electronics and pneumatics along with the following options (where applicable):

- Analog position feedback
- Digital position feedback
- Shutdown module

Housing 2 (remote sensor) contains the position sensor and is suitable for mounting on linear and part-turn actuators.

The following options can be installed if required:

- Optical position indicator
- Mechanical feedback contacts designed as proximity switches or microswitches.

The two housings can be or are connected to a shielded 3-wire cable. The maximum cable length is 10 m.

Installation and commissioning procedures are described in chapters 4 "Mounting", 6 "Pneumatic connection", 7 "Commissioning" and 8 Maintenance ".

Procedures for connecting the electronic unit (housing 1) and the options (housings 1 and 2) are described in chapter 5 "Electrical connections".

With remote sensors designed to protection class IP 67, ensure that the cover screws are pre-tightened with approx. 50 Ncm and then firmly tightened with 250 ± 30 Ncm.



IMPORTANT (NOTE)

If the device is being operated on a cylinder for reasons associated with linearity, you should run the Auto Adjust function for part-turn actuators.

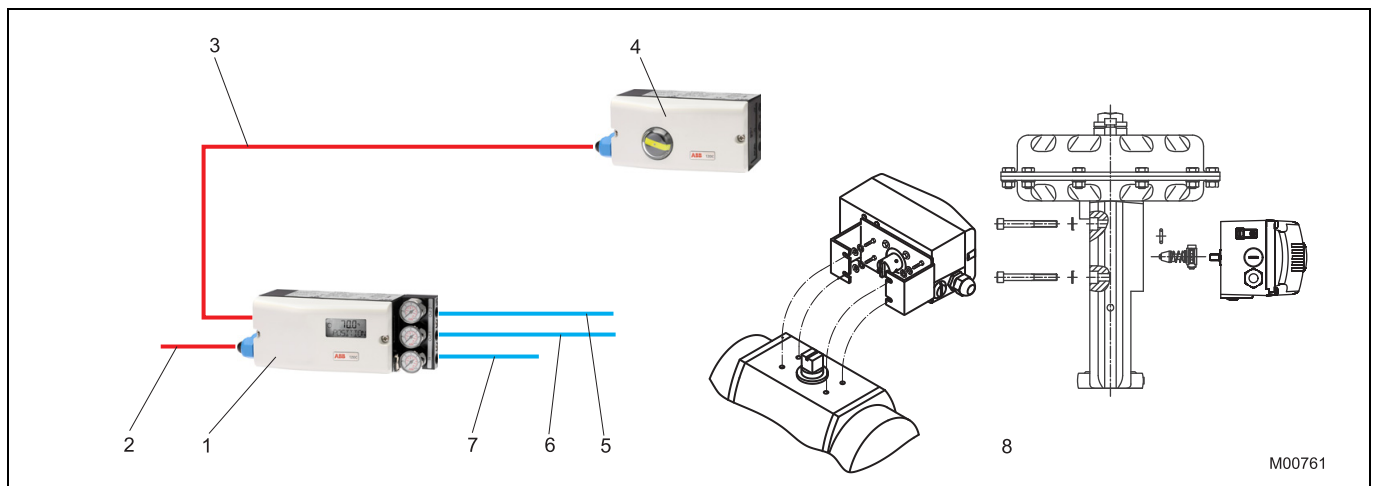

Fig. 21: TZIDC with remote position sensor

- | | |
|-----------------------------|----------------------|
| 1 Housing 1 (control unit) | 5 Pneumatic output 2 |
| 2 Setpoint signal | 6 Pneumatic output 1 |
| 3 Connecting cable | 7 Air supply |
| 4 Housing 2 (remote sensor) | 8 Pneumatic drive |

5.5.1 Electrical connection of TZIDC with remote position sensor

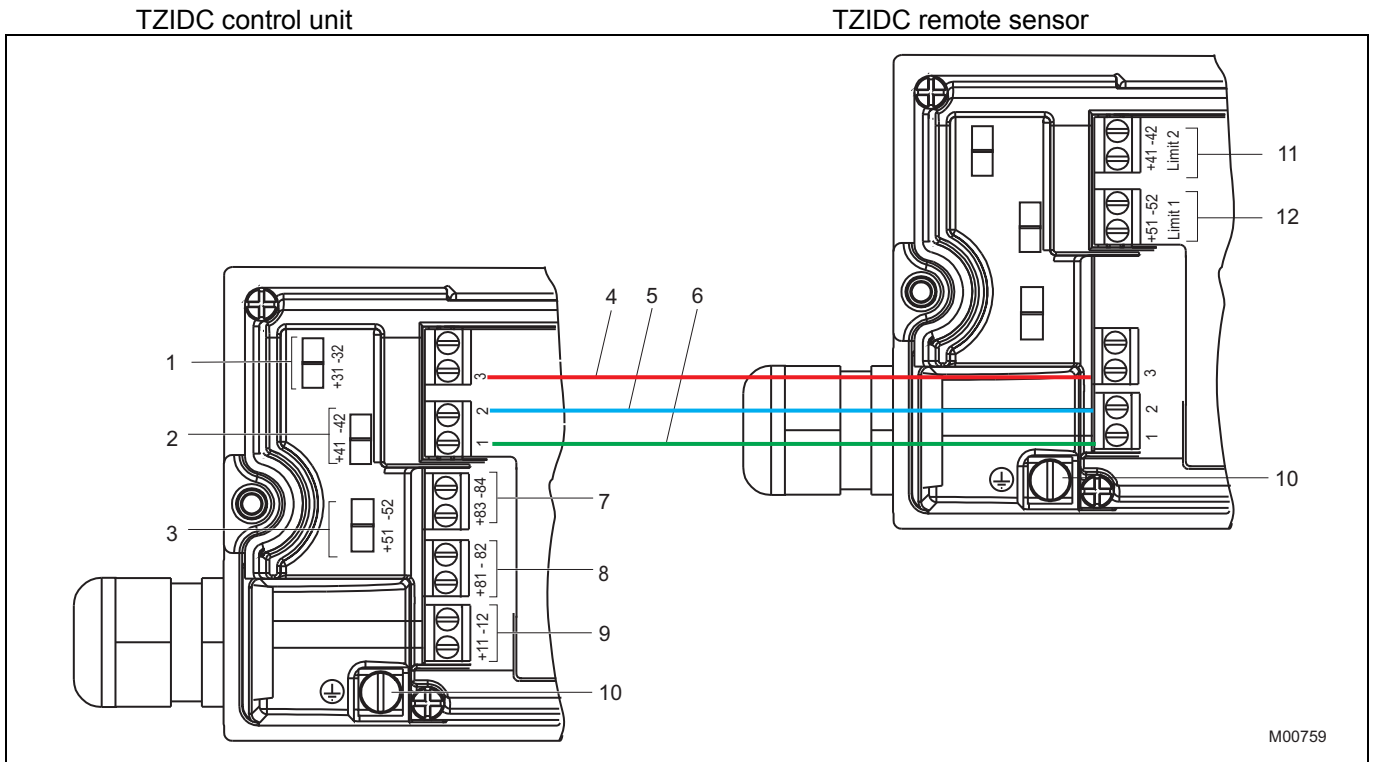

Fig. 22

- | | |
|---|---|
| 1 Analog position feedback | 7 Binary output |
| 2 Digital position feedback switch 1 | 8 Binary input |
| 3 Digital position feedback switch 2 | 9 Setpoint input |
| 4 Connecting cable for remote position sensor | 10 Ground connection |
| 5 Connecting cable for remote position sensor | 11 Proximity switches/Microswitches, switch 1 |
| 6 Connecting cable for remote position sensor | 12 Proximity switches/Microswitches, switch 2 |

i

IMPORTANT (NOTE)

The sensor and the electronics have been carefully matched. Therefore, during installation, please make sure that devices are only connected if they have the same serial number. Connect the connecting cable shield to both housings using EMC cable glands. The pneumatic outputs must be connected to the drive using cables at least 6 mm in diameter. If the control unit is attached so that it is non-conductive, the housing must be grounded (control unit and remote sensor housing at same electrical level); otherwise, control deviations could occur with regard to analog position feedback.

5.6 "TZIDC for remote position sensor"

With the TZIDC designed for remote position sensors, the positioner is supplied without position detection.

The housing (control unit) contains the electronics and pneumatics along with the following options (where applicable):

- Analog position feedback
- Digital position feedback
- Shutdown module

The TZIDC designed for remote position sensors can be connected to any position sensor (4 to 30 kΩ, with open circuit detection 4 to 18 kΩ).

The maximum length of the shielded 3-wire cable is 10 m.

Installation and commissioning procedures are described in chapters 4"Mounting", 6"Pneumatic connection", 7"Commissioning" and 8 „Maintenance“.

Procedures for connecting the electronic unit (housing 1) and the options are described in chapter 5"Electrical connections".



IMPORTANT (NOTE)

If the device is being operated on a cylinder for reasons associated with linearity, you should run the Auto Adjust function for part-turn actuators.

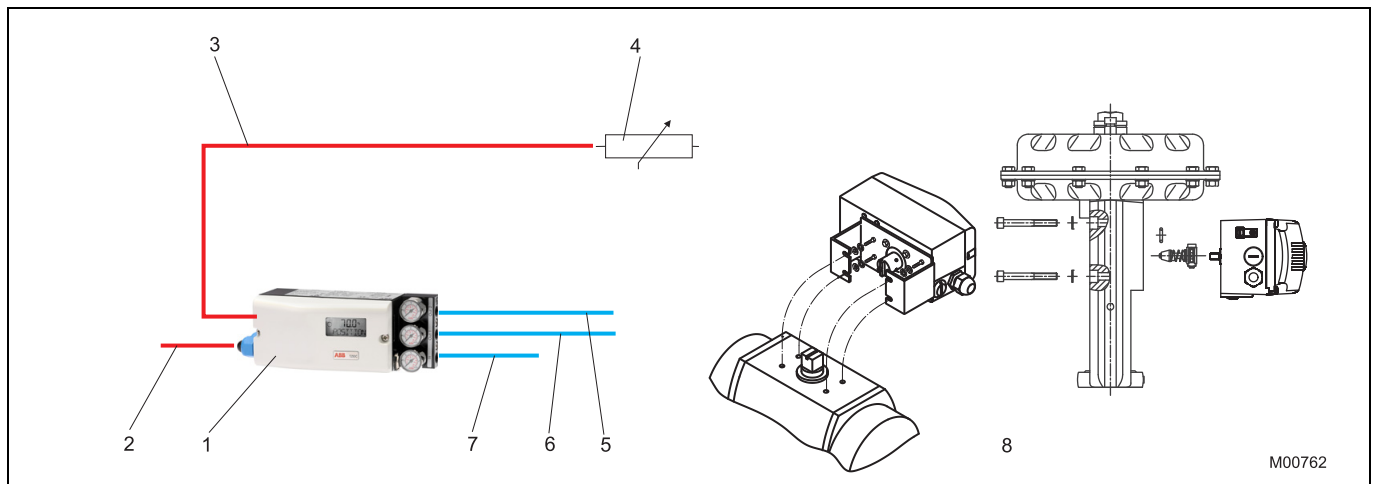

Fig. 23: TZIDC for remote position sensor

- | | |
|--------------------------|----------------------|
| 1 Housing (control unit) | 5 Pneumatic output 2 |
| 2 Setpoint signal | 6 Pneumatic output 1 |
| 3 Connecting cable | 7 Air supply |
| 4 Remote position sensor | 8 Pneumatic drive |

Electrical connections

5.6.1 Electrical connection of TZIDC for remote position sensor

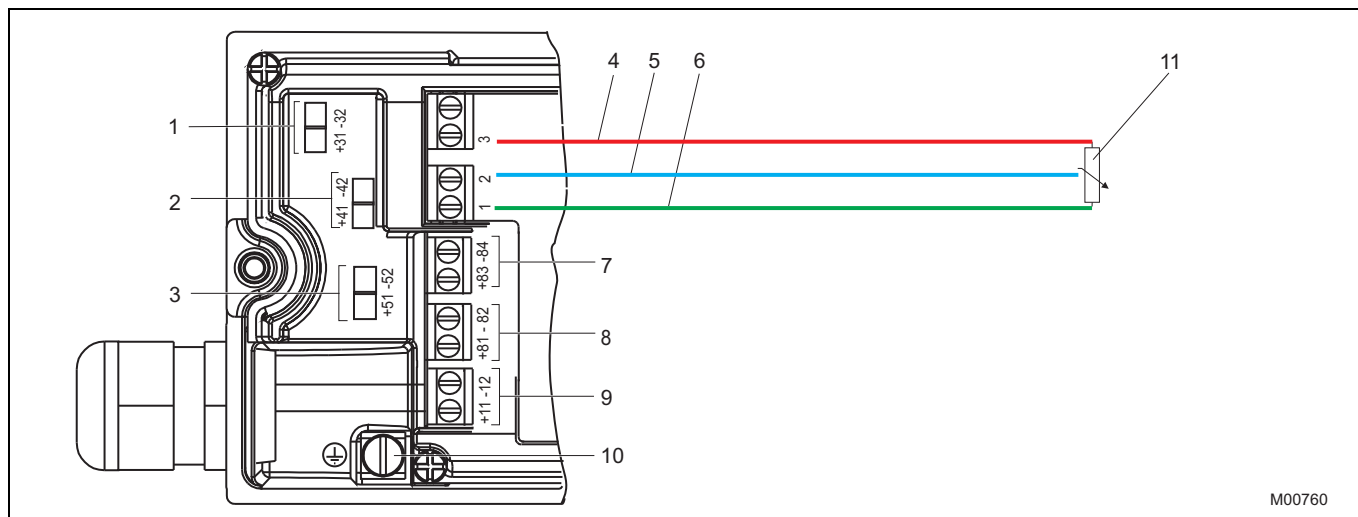

Fig. 24: TZIDC control unit

- | | |
|---|---------------------------|
| 1 Analog position feedback | 7 Binary output |
| 2 Digital position feedback switch 1 | 8 Binary input |
| 3 Digital position feedback switch 2 | 9 Setpoint input |
| 4 Connecting cable for remote position sensor | 10 Ground connection |
| 5 Connecting cable for remote position sensor | 11 Remote position sensor |
| 6 Connecting cable for remote position sensor | |



IMPORTANT (NOTE)

Connect the connecting cable shield to both housings using EMC cable glands.

If the control unit is attached so that it is non-conductive, the housing must be grounded (control unit and remote sensor housing at same electrical level); otherwise, control deviations could occur with regard to analog position feedback.

The pneumatic outputs must be connected to the drive using cables at least 6 mm in diameter.

6 Pneumatic connection



IMPORTANT (NOTE)

The TZIDC, TZIDC-110, TZIDC-120 positioner must be supplied with instrument air that is free of oil, water and dust.

The purity and oil content should meet the requirements of Class 3 according to DIN/ISO 8573-1.



NOTICE - Potential damage to parts!

Impurities on the pipe and positioner can damage components.

The recommended pipe dimension is 6 x 1 mm. Dust, splinters or any other particles must be blown off the pipe before connecting.

To connect the air pipes, G1/4 or 1/4-18 NPT tap holes are provided. We recommend that you use a line with the 6 x 1 mm dimensions.



NOTICE - Potential damage to parts!

Pressure above 6 bar (90 psi) can damage the positioner or actuator.

Provisions should be made to ensure that in the event of an error the pressure does not rise above 6 bar (90 psi).

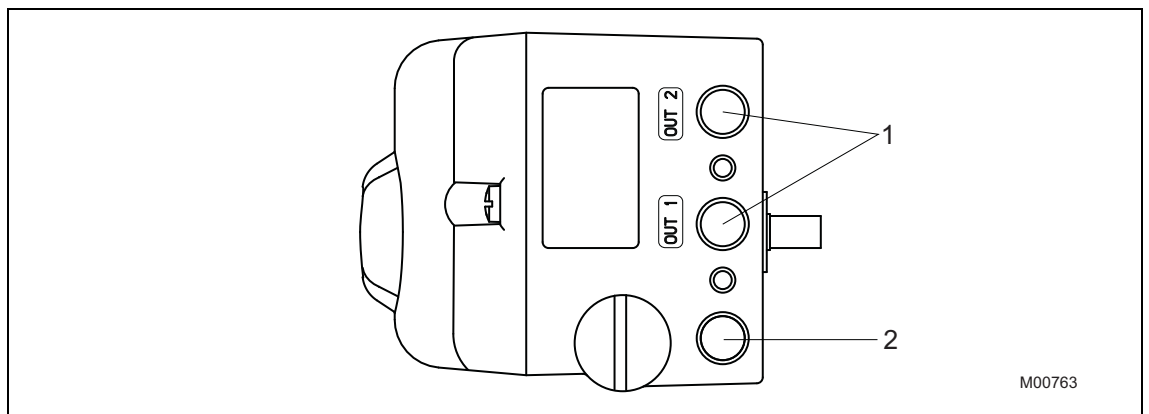

Fig. 25: Pneumatic connections

- 1 Pneumatic outputs
- 2 Supply air

All pneumatic piping connections are located on the right-hand side of the positioner. Tapped holes are provided to connect the pneumatic pipes, G1/4 or 1/4-18 NPT. The positioner is labeled according to the available tapped holes. The corresponding pipe connections must be included.

The level of supply air pressure required to apply the actuating force should be adjusted according to the actuating pressure in the actuator. The positioner operating range is between 1.4 ... 6 bar (20 ... 90 psi).

i

IMPORTANT (NOTE)

With control systems for double-acting spring return actuators, modulation problems may occur due to the spring force combining with the compression force. The pressure values in the springless chamber may exceed those of the supply air as a result of the compression induced by the spring force. This may cause two effects:

Effect 1

The pressure values in the springless chamber exceed the max. permissible limit values. The diaphragms in the I/P module or the actuator may sustain damage leading to device failure as a result.

Effect 2

The pressure in the springless chamber is higher than the service pressure.

If this is the case and if the line to the springless chamber is actuated by the positioner, the excess pressure will first be redirected towards the supply air, and the actuator will move briefly (and inadvertently) in the wrong direction.

In order to ensure that this behavior cannot occur, it is recommended to install a pressure compensation valve between the springless chamber and the supply air for these types of applications. It enables the increased pressure to be transferred back to the air inlet line.

The opening pressure of the check valve should be < 250 mbar.

Join the pipe connections according to the following designation:

Designation	Pipe connection
-	Supply air, pressure 1.4 ... 6 bar (20 ... 90 psi)
OUT1	Actuating pressure for actuator
OUT2	Actuating pressure for actuator (2nd connection with double-acting actuator)

7 Commissioning

7.1 TZIDC

1. Feed in pneumatic supply power
2. Feed in electrical supply power
 - Feed in setpoint current 4 ... 20 mA (terminals +11 / -12)
3. Check mount:
 - Press and hold **MODE**, plus **▲** or **▼** until operating mode 1.3 (manual adjustment within the sensor range) is displayed. Release **MODE**
 - Press **▲** or **▼** to move the actuator into the mechanical end position; check the end positions; rotation angle is displayed in degrees; for high-speed mode, press **▲** and **▼** simultaneously

Recommended range:

 - between -28 ... 28° for linear actuators
 - between -57 ... 57° for part-turn actuators

Minimum angle: 25°
4. Run Autoadjust



IMPORTANT (NOTE)

Autoadjust is available for software version 2.XX and higher.

For linear actuators ¹⁾:

- Press and hold down **MODE** until **ADJ_LIN** is displayed; release the control button
- Press **MODE** again and hold down until the countdown ends
- Release **MODE**; this starts Autoadjust

For part-turn actuators ¹⁾:

- Press **ENTER** and hold down until **ADJ_ROT** is displayed; release the control button
- Press **ENTER** again and hold down until the countdown ends
- Release **ENTER**; this starts Autoadjust

If Autoadjust is successful, the parameters will be stored automatically and the positioner will revert to operating mode 1.1.

If an error occurs during Autoadjust, the process will be terminated with an error message. If this happens, press and hold down **▲** or **▼** for approximately three seconds. The unit will switch to the operating level, mode 1.3 (manual adjustment within the sensor range). The mount is checked and corrected if necessary. Autoadjust then runs again.



IMPORTANT (NOTE)

Autoadjust does not always result in optimum control conditions.

- 1) The zero position is determined automatically and saved during Autoadjust (counter-clockwise (CTCLOCKW) for linear actuators and clockwise (CLOCKW) for part-turn actuators).

7.1.1 Operating modes

Selection from the operating level:

- Press and hold down **MODE**.
- Press and release **▲** rapidly as often as required. The selected operating mode is displayed.
- Release **MODE**.
- The position is displayed in % or as a rotation angle.

Operating mode	Mode indicator	Position indicator
1.0 Control mode ¹⁾ with adaptation (the control parameter)		
1.1 Control mode ¹⁾ without adaptation (the control parameter)		
1.2 Manual adjustment ²⁾ in the operating range. Adjust with ▲ or ▼ ³⁾		
1.3 Manual adjustment ²⁾ in the sensor range. Adjust with ▲ or ▼ ³⁾		

1) Since self-optimization in operating mode 1.0 is subject to several factors during control operation with adaptation, incorrect adjustments could be made over an extended period.

2) Position not active

3) For high-speed mode: Press **▲** and **▼** simultaneously

7.1.2 Sample parameters

"Change the zero position of the LCD screen from clockwise (CLOCKW) to counter-clockwise stop (CTCLOCKW)"

Starting position: The positioner operates in mode 1.1 in the operating level.

1. Switch to the configuration level:
 - Press and hold **▲** and **▼** simultaneously
 - Press **ENTER** briefly
 - Wait until the countdown goes from 3 to 0
 - Release **▲** and **▼**



2. Switch to parameter group 3._:
 - Press and hold **MODE** and **ENTER** simultaneously
 - Press **▲** twice briefly



- Release **MODE** and **ENTER**



3. Select parameter 3.2:
 - Press **MODE** and hold
 - Press **▲** twice briefly



- Release **MODE**

4. Change parameter settings:
 - Press **▲** briefly to select **CTCLOCKW**

5. Switch to parameter 3.3 (Return to operating level) and save the new setup:

- Press **MODE** and hold
- Press **▲** twice briefly



is displayed

- Release **MODE**
- Press **▲** briefly to select **NV_SAVE**
- Press **ENTER** and hold till the countdown goes from 3 to 0

The new parameter setting is saved and the positioner automatically returns to the working level and continues to run in the operating level that was active before calling up the configuration level.

7.2 TZIDC-110 / TZIDC-120

1. Feed in pneumatic supply power
2. Connect the bus to the bus terminals with any polarity (or supply power 9 ... 32 V DC)



is displayed

3. Check mount:
 - Press and hold down **MODE** and **ENTER**; once the countdown has gone from 3 to 0, release **MODE** and **ENTER**; the unit switches to the operating level, mode 1.x
 - Press and hold down **MODE** and **ENTER**.
 - Additionally, press **▲** or **▼** until operating mode 1.3 (manual adjustment within the sensor range) is displayed. Release **MODE**
 - Press **▲** or **▼** to move the actuator into the mechanical end position; check the end positions; rotation angle is displayed in degrees (for high-speed mode, press **▲** and **▼** simultaneously)

Recommended range:

- between -28 ... 28° for linear actuators
- between -57 ... 57° for rotary actuators

Minimum angle: 25°

4. Go back to the bus level:

- Press and hold down **MODE** and **ENTER**; once the countdown has gone from 3 to 0, release **MODE** and **ENTER**



is displayed.

5. Run Autoadjust
 - Check that the unit is on the bus level ("REMOTE")

For linear actuators ¹⁾:

- Press and hold down **MODE** until **ADJ_LIN** is displayed. Release the control button
- Press **MODE** again and hold down until the countdown ends
- Release **MODE**; this starts Autoadjust

For rotary actuators ¹⁾:

- Press and hold down **ENTER** until **ADJ_ROT** is displayed. Release the control button
- Press **ENTER** again and hold down until the countdown ends
- Release **ENTER**; this starts Autoadjust

If Autoadjust is successful, the parameters will be stored automatically and the positioner will revert to operating mode 1.1.

If an error occurs during Autoadjust, the process will be terminated with an error message. If this happens, press and hold down \uparrow or \downarrow for approximately three seconds. The unit will switch to the operating level, mode 1.3 (manual adjustment within the sensor range). The mount is checked and corrected if necessary. Autoadjust then runs again.

6. Set potential dead band and tolerance band

This step is only required for critical (e.g., very small) actuators. It is not necessary under normal circumstances.

- 1) The zero position is determined automatically and saved during Autoadjust (counter-clockwise (CTCLOCKW) for linear actuators and clockwise (CLOCKW) for rotary actuators).

7.2.1 Operating modes

Selection from the operating level:

- Press and hold down **MODE**
- Press and release \uparrow as often as required to display the selected operating mode
- Release **MODE**
- The position is displayed in % or as a rotation angle

Operating mode	Mode indicator	Position indicator
1.1 Positioning with fixed setpoint Use \uparrow or \downarrow to adjust the setpoint		
1.2 Manual adjustment ¹⁾ in the operating range Adjust with \uparrow or \downarrow ²⁾		
1.3 Manual adjustment ¹⁾ in the sensor range Adjust with \uparrow or \downarrow ²⁾		

1) Positioning not active.
2) for high-speed mode: Press \uparrow and \downarrow simultaneously.

7.2.2 Sample parameters

"Change the zero position of the LCD screen from clockwise (CLOCKW) to counter-clockwise stop (CTCLOCKW)"

Starting position: The positioner is in bus operation on the operating level

1. Switch to the configuration level:

- Press and hold down **▲** and **▼** simultaneously
- Press and release **ENTER**
- Wait for the countdown to go from 3 to 0
- Release **▲** and **▼**,



2. Switch to parameter group 3. _:

- Press and hold down **MODE** and **ENTER** simultaneously
- Press and release **▲** twice,



- Release **MODE** and **ENTER**,



3. Select parameter 3.2:

- Press and hold down **MODE**
- Press and release **▲** twice,



- Release **MODE**

4. Change parameter settings:

- Press and release **▲** to select **CTCLOCKW**

5. Switch to parameter 3.3 (Return to operating level) and save the new setting:

- Press and hold down **MODE**
- Press and release **↑** twice,



is displayed

- Release **MODE**
- Press and release **↑** to select **NV_SAVE**
- Press and hold down **ENTER** until the countdown goes from 3 to 0

The new parameter setting is saved and the positioner automatically returns to the working level, continuing to run on the operating level that was active prior to the configuration level being called up.

8 Maintenance



IMPORTANT (NOTE)

In case of manipulation by users, the warranty for the device is no longer valid.

Note that the supplied instrument air must be free of oil, water and dust according to DIN/ISO 8573-1 to ensure trouble-free operation.

Essentially no maintenance is required for the TZIDC, TZIDC-110, TZIDC-120 positioner.



IMPORTANT (NOTE)

Perform a functional check of the emergency shutdown module (option) at least every 2 years.

8.1 Functional check for emergency shutdown module



IMPORTANT (NOTE)

When using the emergency shutdown module, a functional check must be performed at least every two years.

Procedure:

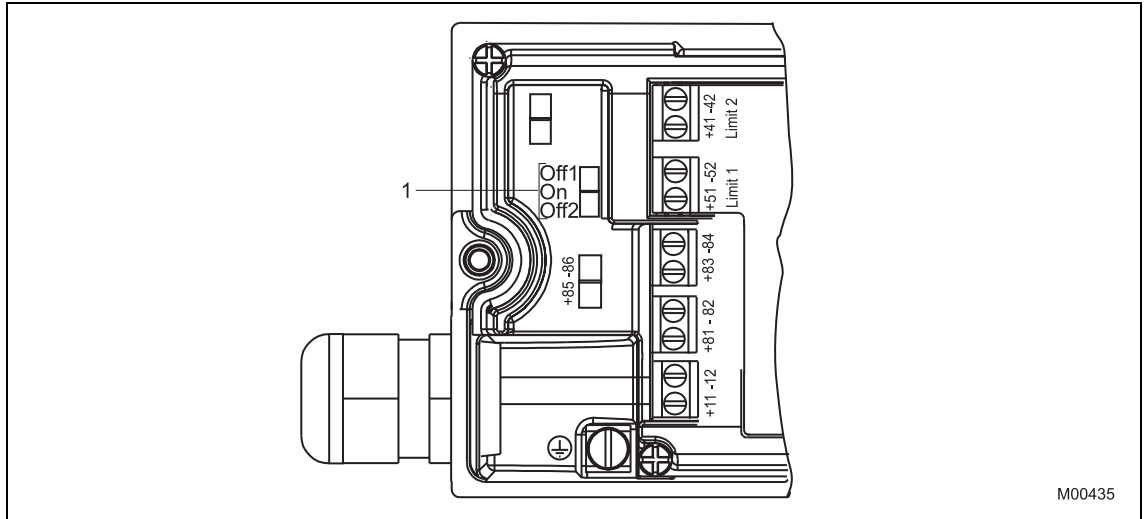

Fig. 26: Slide switch for emergency shutdown module

1. Open the housing cover.
2. Move the slide switch (1) from center position "On" to the upper and lower switch positions ("Off1" or "Off2"), and check whether the actuator is depressurized.
3. Reset the slide switch to the center position ("On") after the functional check.
4. Replace the housing cover.

9 Specifications

9.1 TZIDC

9.1.1 Input

Setpoint signal (two-wire technology)

Nominal range	4 ... 20 mA
Split range configuration between	20 ... 100 % of the nominal range
Max.	50 mA
Min.	3.6 mA
Starting at	3.8 mA
Load voltage at 20 mA	9.7 V
Impedance at 20 mA	485 Ω

Digital input

Control voltage	0 ... 5 V DC logical switching state "0" 11 ... 30 V DC logical switching state "1"
Current	max. 4 mA

9.1.2 Output

Compressed air output

Range	0 ... 6 bar (0 ... 90 psi)
Air capacity	5.0 kg/h = 3.9 Nm ³ /h = 2.3 scfm at 1.4 bar (20 psi) supply pressure 13 kg/h = 10 Nm ³ /h = 6.0 scfm at 6 bar (90 psi) supply pressure
Output function	For single or double-acting actuators, air is vented from actuator or actuator is blocked in case of (electrical) power failure
Shut-off values	End position 0 % = 0 ... 45 % End position 100 % = 55 ... 100 %

Digital output (control circuit to DIN 19234 / NAMUR)

Supply voltage	5 ... 11 V DC
Current > 0.35 mA ... < 1.2 mA	Switching state logical "0"
Current > 2.1 mA	Switching state logical "1"
Effective direction (configurable)	normally logical "0" or logical "1"

9.1.3 Travel

Rotation angle

Used range	25 ... 120° (rotary actuators, optional 270°) 25 ... 60° (linear actuators)
Travel limit	Min. and max. limits, freely configurable between 0 ... 100 % of total travel (min. range > 20 %)
Travel time prolongation	Range of 0 ... 200 s, separately for each direction
Dead band time limit	Setting range 0 ... 200 s (monitoring parameter for control until the deviation reaches the dead band)

9.1.4 Air supply

Instrument air

free of oil, water and dust to DIN/ISO 8573-1. Pollution and oil content according to Class 3 (purity: max. particle size = 5 μm, max. particle density = 5 mg / m³; oil content: max. concentration = 1 mg / m³; pressure dew point: 10 K below operating temperature)

Supply pressure

1.4 ... 6 bar (20 ... 90 psi)

i IMPORTANT (NOTE)

Do not exceed the maximum operating pressure of the actuator!

Air consumption

< 0.03 kg/h / 0.015 scfm (independent of supply pressure)

9.1.5 Transmission data and influences

Output Y1

Increasing Increasing setpoint signal 0 ... 100 %
 Increasing pressure at output

Decreasing Increasing setpoint signal 0 ... 100 %
 Decreasing pressure at output

Action (setpoint signal)

Increasing Signal 4 ... 20 mA = actuator position 0 ... 100 %
 Decreasing Signal 20 ... 4 mA = actuator position 0 ... 100 %

Characteristic curve (travel = f {setpoint signal})

Linear, equal percentage 1:25 or 1:50 or 25:1 or 50:1 and freely configurable with 20 reference points.

Deviation ≤ 0,5 %
 Tolerance band 0.3 ... 10 %, adjustable
 Dead band 0.1 ... 10 %, adjustable
 Resolution (A/D conversion) > 16000 steps
 Sample rate 20 ms
 Influence of ambient temperature ≤ 0.5 % per 10 K
 Influence of vibration ≤ 1 % to 10 g and 80 Hz

Seismic vibration

Meets requirements of DIN / IEC 68-3-3 Class III for strong and strongest earthquakes.

Influence of mounting orientation

Not measurable.

Complies with the following directives

- EMC Directive 2014/30/EU
- EC Directive for CE conformity marking

Communication

- HART Protocol 5.9
- Local connector for LKS (not in Ex area)
- HART communication via 20 mA signal line with (optional) FSK modem

9.1.6 Environmental capabilities

Ambient temperature

For operation, storage and transport: -40 ... 85 °C (-40 ... 185 °F)

When using proximity switches SJ2-S1N (NO): -25 ... 85 °C (-13 ... 185 °F)

Relative humidity

Operational (with closed housing and air supply switched on): 95 % (annual average), condensation permissible

Transport and storage: 75 % (annual average), non-condensing

9.1.7 Housing

Material / Degree of protection

Aluminum, protection class IP 65 (optional IP 66) / NEMA 4X

Surface / Color

Electrostatic dipping varnish with epoxy resin, stove-hardened. Case varnished black, RAL 9005, matte, housing cover Pantone 420.

Electrical connections

Screw terminals: Max. 1.0 mm² (AWG 17) for options
 Max. 2.5 mm² (AWG 14) for
 4 ... 20 mA input signal

i IMPORTANT (NOTE)

Do not expose the terminals to strain.

Four thread combinations for cable entry and pneumatic connection

- Cable: thread 1/2-14NPT, air pipe: thread 1/4-18 NPT
 - Cable: thread M20 x 1,5, air pipe: thread 1/4-18 NPT
 - Cable: thread M20 x 1,5, air pipe: thread G 1/4
 - Cable: thread G 1/2, air pipe: thread Rc 1/4
- (Optional: With cable gland(s) and pipe plugs if necessary)

Weight

1.7 kg (3.75 lb)

Mounting orientation

Any

9.1.8 Safety Integrity Level

i IMPORTANT (NOTE)

Applies to applications with single-acting and depressurizing pneumatics.

The positioner TZIDC / TZIDC-200 and the emergency shutdown module for meet the requirements regarding:

- functional safety acc. to IEC 61508
- explosion protection (depending on the model)
- electromagnetic compatibility in accordance with EN 61000

Without the input signal, the pneumatic module in the positioner vents the drive and the installed spring in it moves the valve in a predetermined end position (OPEN or CLOSED).

SIL specific safety-related characteristics:

Device	SFF	PFDav	$\lambda_{dd} + \lambda_s$	λ_{du}
TZIDC / TZIDC-200 as shutdown module	94 %	1.76 * 10 ⁻⁴	718 FIT	40 FIT
TZIDC / TZIDC-200 with supply current 0 mA	94 %	1.76 * 10 ⁻⁴	651 FIT	40 FIT

For details refer to the Management Summary in the SIL-Safety Instructions 37/18-79XA.

Specifications

9.1.9 Options

Module for analog position feedback ¹⁾

Signal range	4 ... 20 mA (configurable split ranges)
Supply, 2-wire circuitry	24 V DC (10 ... 30 V DC) 48 V DC (20 ... 48 V DC, no ignition protection)
Characteristic curve (configurable)	Rising or falling
Deviation	< 1 %

i IMPORTANT (NOTE)

Without a signal from the positioner (e.g., "no power" or "initializing") the module sets the output to > 20 mA (alarm level)

Module for digital position feedback ¹⁾

Two switches for digital position feedback (position adjustable within the range of 0 ... 100 %, ranges cannot overlap)	
Current circuits acc. to DIN 19234 / NAMUR	
Supply voltage	5 ... 11 V DC
Signal current < 1.2 mA	Switching state logical "0"
Signal current > 2.1 mA	Switching state logical "1"
Direction of action	normally logical "0" or logical "1" (configurable)

Module for the emergency shutdown function ²⁾

Supply voltage	24 V DC (20 ... 30 V DC) (galvanically isolated from input signal)
Safe position is activated when	Voltage < 5 V
SIL	See "Safety Integrity Level"

A separate 24 V DC signal is normally applied to the emergency shutdown module, which connects through the signal from the microprocessor to the I/P module.

When the 24 V DC signal is interrupted, the I/P module executes the respective safety function, depending on the mechanical construction. The positioner output 1 is depressurized, and the valve is moved to the safe position. In case of a double-acting actuator the second output 2 is additionally pressurized.

i IMPORTANT (NOTE)

The emergency shutdown module can only be used with pneumatics with the safe position "fail-safe".

The emergency shutdown module works independently of the mother board, i.e. all information from the final control element is available in the supervisory process control system at any time.

- 1) The module for analog position feedback and the module for digital position feedback plug in separate slots and can be used together.
- 2) The module for the emergency shutdown function uses the same space as the module for analog feedback and the module for analog or digital feedback and cannot be plugged in and run together with any of them.

Digital position feedback with proximity switches

Two proximity switches for independent position signaling, Switching points adjustable between 0 ... 100 %	
Current circuits acc. to DIN 19234 / NAMUR	
Supply voltage	5 ... 11 V DC
Signal current < 1.2 mA	Switching state logical "0"
Signal current > 2.1 mA	Switching state logical "1"

Direction of action (logical state)

Proximity switch	Position			
	< Lim. 1	> Lim. 1	< Lim. 2	> Lim. 2
SJ2-SN (NC)	0	1	1	0
SJ2-S1N (NO)	1	0	0	1

i IMPORTANT (NOTE)

When using proximity switch SJ2_S1N (NO), the positioner may only be used at an ambient temperature range -25 ... 85 °C (-13 ... 185 °F).

Digital position feedback with 24 V microswitches

Two microswitches for independent position signaling. Switching points can be adjusted from 0 ... 100 %.	
Voltage	max. 24 V AC / DC
Load rating	max. 2 A
Contact surface	10 µm Gold (AU)

Mechanical position indicator

Indicator disk in enclosure cover linked with positioner feedback shaft.

i IMPORTANT (NOTE)

These options are also available for retrofitting by Service.

9.1.10 Accessories

Mounting material

- Attachment kit for linear actuators to DIN/IEC 534 / NAMUR
- Attachment kit for part-turn actuators to VDI / VDE 3845
- Attachment kit for integral mounting to control valves
- Attachment kit for actuator-specific attachment upon request

Pressure gauge block

- With pressure gauges for supply and output pressure.
- Pressure gauges with housing \varnothing 28 mm
- Aluminum connection block in black
- Installation material in black for mounting to TZIDC

Filter regulator

All metal version in brass, varnished black, bronze filter element, (40 μ m) , with condensate drain.
max. pre-pressure 16 bar (232 psi), output adjustable to 1.4 ... 6 bar (20 ... 90 psi).

i IMPORTANT (NOTE)
The filter regulator may only be installed in combination with the pressure gauge block (accessory).

PC adapter for communication

LKS adapter for plug-in connection to TZIDC
FSK modem for HART communication

PC software for remote configuration and operation

DAT200 Asset Vision Basic with DTM for TZIDC on CD-ROM

9.2 TZIDC-110

9.2.1 Communication

Profiles	Profibus PA profile for process devices Electro-pneumatic actuators V3.0
Block types	1 AO Functional block 1 Transducer block 1 physical block
Physical Layer	In compliance with IEC 61158-2
Transmission rate	31.25 Kbit/s
Supply voltage	Power feed from the PA bus, 9.0 ... 32.0 V DC
Max. permissible voltage	35 V DC
Power consumption	10.5 mA
Current in the event of an error	15 mA (10.5 mA + 4.5 mA)

9.2.2 Device name

Device name	TZIDC-X10
PNO ID no.	0x0639
Dev. ID	0X3200028xyz
Bus address	Between 0 and 126, default address 126

9.2.3 Output

Range	0 ... 6 bar (0 ... 90 psi)
Air capacity	at 1.4 bar (20 psi) supply pressure 5.0 kg/h = 3.9 Nm ³ /h = 2.3 scfm at supply pressure of 6 bar (90 psi) 13 kg/h = 10 Nm ³ /h = 6.0 scfm
Output function	For single or double-acting actuators, air is vented from actuator or actuator is blocked in case of (electrical) power failure
Shut-off values	end position 0 % = 0 ... 45 % end position 100 % = 55 ... 100 %

9.2.4 Travel

Rotation angle	
Used range	25 ... 120° 25 ... 60°
	rotary actuators, optionally 270° linear actuators

Travel time prolongation

Setting range	0 ... 200 seconds, separately for each direction
----------------------	--

9.2.5 Air supply

Instrument air	free of oil, water and dust to DIN/ISO 8573-1. Pollution and oil content according to Class 3 (purity: max. particle size = 5 μ m, max. particle density = 5 mg / m ³ ; oil content: max. concentration = 1 mg / m ³ ; pressure dew point: 10 K below operating temperature)
Supply pressure	1.4 ... 6 bar (20 ... 90 psi)

i IMPORTANT (NOTE)
Do not exceed the maximum operating pressure of the actuator!

Air consumption	< 0.03 kg/h / 0.015 scfm (independent of supply pressure)
------------------------	---

Specifications

9.2.6 Transmission data and influences

Output Y1

Increasing:	Increasing output signal 0 ... 100 % Increasing pressure at output Y1
Decreasing:	Increasing output signal 0 ... 100 % Decreasing pressure at output Y1

Characteristic deviation	≤ 0,5 %
Tolerance band	0.3 ... 10 %, adjustable
Dead band	0,1 ... 10 %, adjustable
Resolution (A/D conversion)	> 16000 steps
Sample rate	20 ms
Influence of ambient temperature	≤ 0.5 % per 10 K
Influence of vibration	≤ ± 1 % to 10 g and 80 Hz

Seismic requirements

Meets requirements of DIN / IEC 68-3-3 Class III for strong and strongest earthquakes.

Influence of mounting orientation

Not measurable.

Meets the requirements of the following directives

- EMC Directive 2014/30/EU
- EC Directive for CE conformity marking

9.2.7 Environmental capabilities

Ambient temperature

For operation, storage and transport:	-40 ... 85 °C (-40 ... 185 °F)
When using proximity switches SJ2-S1N (NO):	-25 ... 85 °C (-13 ... 185 °F)

Relative humidity

Operational (with closed housing and air supply switched on):	95 % (annual average), condensation permissible
Transport and storage:	75 % (annual average), non-condensing

9.2.8 Housing

Material / Degree of protection

Aluminum with ≤ 0.1 % copper, protection class IP 65 (optional IP 66) / NEMA 4X

Surface / Color

Electrostatic dipping varnish with epoxy resin, stove-hardened. Case varnished black, RAL 9005, matte, housing cover Pantone 420.

Electrical connections

Screw terminals:	Max. 1.0 mm ² (AWG 17) for options Max. 2.5 mm ² (14 AWG) for bus connector
------------------	--

i IMPORTANT (NOTE)

Do not expose the terminals to strain.

Four thread combinations for cable entry and pneumatic connection

- Cable: thread 1/2-14NPT, air pipe: thread 1/4-18 NPT
 - Cable: thread M20 x 1,5, air pipe: thread 1/4-18 NPT
 - Cable: thread M20 x 1,5, air pipe: thread G 1/4
 - Cable: thread G 1/2, air pipe: thread Rc 1/4
- (Optional: With cable gland(s) and pipe plugs if necessary)

Weight

1,7 kg (3,75 lb)

Mounting orientation

Any

9.2.9 Options

Module for the emergency shutdown function

Supply voltage	24 V DC (20 ... 30 V DC) (galvanically isolated from input signal)
Safe position is activated when Explosion protection	voltage < 5 V see certificate (operating instructions)

A separate 24 V DC signal is normally applied to the emergency shutdown module, which connects through the signal from the microprocessor to the I/P module.

When the 24 V DC signal is interrupted, the pneumatic module executes the respective safety function, depending on the mechanical construction.

The positioner output Y1 is depressurized, and the valve is moved to the safe position. In case of a double-acting actuator the second output Y2 is additionally pressurized.

i IMPORTANT (NOTE)

The emergency shutdown module can only be used with pneumatics with the safe position "fail-safe".

The emergency shutdown module works independently of the mother board, i.e. all information from the final control element is available in the supervisory process control system at any time.

Digital position feedback with proximity switches ¹⁾

Two proximity switches for independent position signaling. Switching points adjustable between 0 ... 100 %

Current circuits acc. to DIN 19234 / NAMUR

Supply voltage	5 ... 11 V DC
Signal current < 1 mA	Switching state logical "0"
Signal current > 2 mA	Switching state logical "1"

Direction of action (logical state)

Proximity switch	Position			
	< Lim. 1	> Lim. 1	< Lim. 2	> Lim. 2
SJ2-SN (NC)	0	1	1	0
SJ2-S1N (NO)	1	0	0	1

i IMPORTANT (NOTE)
When using SJ2_S1N (NO), the TZIDC positioner may only be used at an ambient temperature range from -25 ... 85 °C (-13 ... 185 °F).

Digital position feedback with 24 V microswitches ¹⁾

Two microswitches for independent position signaling. Switching points adjustable between 0 ... 100 %.

Voltage max. 24 V AC / DC
Load rating max. 2 A
Contact surface 10 µm Gold (AU)

Mechanical position indicator

Indicator disk in enclosure cover, linked with positioner feedback shaft.

i IMPORTANT (NOTE)
These options are also available for retrofitting by Service.

¹⁾ The proximity switches or 24 V microswitches for digital feedback are activated directly via the positioner axis and can only be used in combination with the optionally available mechanical position indicator.

9.2.10 Accessories

Mounting material

- Attachment kit for linear actuators to DIN/IEC 534 / NAMUR
- Attachment kit for rotary actuators to VDI / VDE 3845
- Attachment kit for integral mounting to control valves
- Attachment kit for actuator-specific attachment upon request

Pressure gauge block

- With pressure gauges for supply and output pressure.
- Pressure gauges with housing ø 28 mm (1.1 inch), with connection block in aluminum, black
- Installation material for mounting on positioner

Filter regulator

All metal version in brass, varnished black, bronze filter element (40 µm) and condensate drain.
Max. pre-pressure 16 bar (232.06 psi), output adjustable to 1.4 ... 6 bar (20 ... 90 psi)

PC software for configuration and operation

DSV401 (SMART VISION) with DTM available on CD-ROM

9.3 TZIDC-120

9.3.1 Communication

Specification	FOUNDATION fieldbus, version 1.5
Physical Layer	Model 113, 121 (IEC 61158-2)
Transmission rate	31.25 Kbit/s
Block types	1 AO Function block 1 PID block 1 Resource block 1 Transducer block 1 physical block
Block class	AO block: standard PID block: enhanced Resource block: enhanced Transducer block: custom
Number of linkage objects	22
Device description (DD)	Rev. No. 1 (file name 0201.ffo, 0201.sym)
File	Common file format (file name: 020101.cff)
Max. execution time	AO block: 40 milliseconds PID block: 50 milliseconds
Supply voltage	Power feed from the fieldbus 9.0 ... c 32.0 V DC
Max. permissible voltage	35 V DC
Power consumption	11.5 mA
Current in the event of an error	15 mA (11.5 mA + 3.5 mA)
FF Certification	Registered with ITK 4.51, Dec.2003 IT Camp. Number IT023200
Device name	ABB TZIDC, TZIDC-110, TZIDC-120-TAG
Dev. ID	0003200028-TZIDC, TZIDC-110, TZIDC-120XXXXXXXXXX
Device address	Between 10 and 247, default address 23
ATEX certificate for FISCO	Yes
Insensitive to reversed polarity	Yes
Class	LM profile 32L, 31 PS
Factory default	The positioner is not delivered in an aligned state. To adjust the operating range and control parameters, an automatic configuration must be run on the unit. Otherwise, the transducer block remains in out-of-service mode.
Diagnostic functions	Self-diagnostics for the positioner hardware and software, valve diagnostics with enhanced alarm handling

Specifications

9.3.2 Device name

Device name	ABB TZID-C120-TAG
Dev. ID	0003200028-TZID-C120XXXXXXXXXX

9.3.3 Output

Range	0 ... 6 bar (0 ... 90 psi)
Air capacity	
at 1.4 bar (20 psi) supply pressure	5.0 kg/h = 3.9 Nm ³ /h = 2.3 scfm
at 6 bar (90 psi) supply pressure	13 kg/h = 10 Nm ³ /h = 6.0 scfm
Output function	For single or double-acting actuators, air is vented from actuator or actuator is blocked in case of (electrical) power failure
Shut-off values	End Position 0 % = 0 ... 45 % End position 100 % = 55 ... 100 %

9.3.4 Travel

Rotation angle	
Used range	
25 ... 120°	rotary actuators, optionally 270°
25 ... 60°	linear actuators

Travel time prolongation

Setting range	0 ... 200 seconds, separately for each direction
---------------	--

9.3.5 Air supply

Instrument air	free of oil, water and dust to DIN/ISO 8573-1. Pollution and oil content according to Class 3 (purity: max. particle size = 5 µm, max. particle density = 5 mg / m ³ ; oil content: max. concentration = 1 mg / m ³ ; pressure dew point: 10 K below operating temperature)
Supply pressure	1.4 ... 6 bar (20 ... 90 psi)

i IMPORTANT (NOTE)

Do not exceed the maximum operating pressure of the actuator!

Air consumption	< 0.03 kg/h / 0.015 scfm (independent of supply pressure)
------------------------	---

9.3.6 Transmission data and influences

Direction of action (output signal or pressure in actuator)	
Increasing	Increasing output signal 0 ... 100 % Increasing pressure y1 in the actuator
Decreasing	Increasing output signal 0 ... 100 % Decreasing pressure y1 in the actuator

Characteristic deviation	< 0.5 %
Tolerance band	0.3 ... 10 %, adjustable
Dead band	0.1 ... 5 %, adjustable
Resolution (A/D conversion)	> 16000 steps
Sample rate	20 ms
Influence of ambient temperature	< 0.5 % for each 10 K
Influence of vibration	≤ ± 1 % to 10 g and 80 Hz

Seismic requirements

Meets requirements of DIN / IEC 68-3-3 Class III for strong and strongest earthquakes.

Influence of mounting orientation

Not measurable.

Meets the requirements of the following directives

- EMC Directive 2014/30/EU
- EC Directive for CE conformity marking

9.3.7 Environmental capabilities

Ambient temperature

For operation, storage and transport: -40 ... 85 °C (-40 ... 185 °F)

When using proximity switches SJ2-S1N (NO): -25 ... 85 °C (-13 ... 185 °F)

Relative humidity

Operational (with closed housing and air supply switched on): 95 % (annual average), condensation permissible
Transport and storage: 75 % (annual average), non-condensing

9.3.8 Housing

Material / Degree of protection

Aluminum with ≤ 0.1 % copper, protection class IP 65 (optional IP 66) / NEMA 4X

Surface / Color

Electrostatic dipping varnish with epoxy resin, stove-hardened.
Case varnished black, RAL 9005, matte, housing cover Pantone 420.

Electrical connections

Screw terminals: Max. 1.0 mm² (AWG 17) for options
Max. 2.5 mm² (14 AWG) for bus connector

i IMPORTANT (NOTE)
Do not expose the terminals to strain.

Four thread combinations for cable entry and pneumatic connection

- Cable: thread 1/2-14NPT, air pipe: thread 1/4-18 NPT
 - Cable: thread M20 x 1,5, air pipe: thread 1/4-18 NPT
 - Cable: thread M20 x 1,5, air pipe: thread G 1/4
 - Cable: thread G 1/2, air pipe: thread Rc 1/4
- (Optional: With cable gland(s) and pipe plugs if necessary)

Weight

1,7 kg (3,75 lb)

Mounting orientation

Any

9.3.9 Options

Module for the emergency shutdown function

Supply voltage 24 V DC (20 ... 30 V DC)
(electrically isolated from input signal)

Safe position is activated when Voltage < 5 V

Explosion protection see certificate (operating instructions)

A separate 24 V DC signal is normally applied to the emergency shutdown module, which connects through the signal from the microprocessor to the I/P module.

When the 24 V DC signal is interrupted, the pneumatic module executes the respective safety function, depending on the mechanical construction:

The positioner output Y1 is depressurized, and the valve is moved to the safe position. In the case of a double-acting actuator, output Y2 is additionally pressurized.

i IMPORTANT (NOTE)
The emergency shutdown module can only be used with pneumatics with the safe position "fail-safe".

The emergency shutdown module works independently of the mother board, i.e. all information from the final control element is available in the supervisory process control system at any time.

Mechanical position indicator

- Indicator disk
- Cover with transparent dome
- Symbol label
- Extension shaft

Digital position feedback with proximity switches

Two proximity switches for independent position signaling. Switching points adjustable between 0 ... 100 %
Current circuits acc. to DIN 19234 / NAMUR
Supply voltage 5 ... 11 V DC
Signal current < 1.2 mA Switching state logical "0"
Signal current > 2.1 mA Switching state logical "1"
(function dependent on software and electronics for actuator)

Direction of action (logical state)

Proximity switch	Position			
	< Lim. 1	> Lim. 1	< Lim. 2	> Lim. 2
SJ2-SN (NC)	0	1	1	0
SJ2-S1N (NO)	1	0	0	1

Digital position feedback with 24 V microswitches*

Two microswitches for independent position signaling. Switching points adjustable between 0 ... 100 %.
Voltage max. 24 V AC / DC
Load rating max. 2 A
Contact surface 10 µm Gold (AU)

Mechanical position indicator

Indicator disk in enclosure cover, linked with positioner feedback shaft.

* The "digital feedback" is activated directly from the axis of rotation for the variable pick-off and can only be used with the "mechanical position indicator".

i IMPORTANT (NOTE)
These options are also available for retrofitting by Service.

9.3.10 Accessories

Mounting material

- Attachment kit for linear actuators to DIN / IEC 534 / NAMUR
- Attachment kit for part-turn actuators to VDI / VDE 3845
- Attachment kit for integral mounting to control valves
- Attachment kit for actuator-specific attachment upon request

Pressure gauge block

- Pressure gauges for supply and output pressure
- Pressure gauges with housing ø 28 mm
- Aluminum connection block in black
- Installation material for mounting on positioner

Filter regulator

All metal version in brass, varnished black, bronze filter element (40 µm) and condensate drain.
Max. pre-pressure 16 bar (232 psi), output adjustable to 1.4 ... 6 bar (20 ... 90 psi)

10 Ex relevant specifications

IMPORTANT (NOTE)

The values indicated here are taken from the respective certificates. Always observe the specifications and supplements in the explosion protection certificates.

10.1 TZIDC
10.1.1 ATEX Ex i

Designation:	II 2 G Ex ia IIC T6 resp. T4 Gb II 2 G Ex ib IIC T6 resp. T4 Gb II 2 D Ex ia IIIC T51°C resp. 81°C Db
Type Examination Test Certificate:	TÜV 04 ATEX 2702 X
Type:	Intrinsically safe equipment
Device class:	II 2G
Standards:	EN 60079-0:2009 EN 60079-11:2012
Device class:	II 2D
Standards:	EN 60079-0:2009 EN 61241-11:2006

II 2 G Temperature class	Ta Ambient temperature range
T4	-40 ... 85 °C
T5	-40 ... 50 °C
T6 ¹⁾	-40 ... 40 °C

1) When using the "digital feedback" plug-in module in temperature class T6, the maximum permissible ambient temperature range is -40 ... 35 °C.

II 2 D Housing surface temperature	Ta Ambient temperature range (II 2 D)
T81 °C	-40 ... 70 °C
T61 °C	-40 ... 50 °C
T51 °C	-40 ... 40 °C

Electrical data

	With the intrinsically safe Ex ib IIC, Ex ia IIC or Ex ia IIIC type of ignition protection, only for connection to a certified intrinsically safe circuit.
Signal circuit (terminal +11 / -12)	Maximum values: $U_i = 30 \text{ V}$ $I_i = 320 \text{ mA}$ $P_i = 1.1 \text{ W}$ $C_i = 6.6 \text{ nF}$ L_i negligibly small
Contact input (terminal +81 / -82)	Maximum values: $U_i = 30 \text{ V}$ $I_i = 320 \text{ mA}$ $P_i = 1.1 \text{ W}$ $C_i = 4.2 \text{ nF}$ L_i negligibly small
Switch output (terminal +83 / -84)	Maximum values: $U_i = 30 \text{ V}$ $I_i = 320 \text{ mA}$ $P_i = 500 \text{ mW}$ $C_i = 4.2 \text{ nF}$ L_i negligibly small
Mechanical digital feedback (terminal limit1 +51 / -52 or limit2 +41 / -42)	For max. values, see EC type examination test certificate number PTB 00 ATEX 2049 X Proximity switches manuf. by Pepperl & Fuchs
Plug-in module for digital position feedback (terminal +51 / -52 or +41 / -42)	Maximum values: $U_i = 30 \text{ V}$ $I_i = 320 \text{ mA}$ $P_i = 500 \text{ mW}$ $C_i = 3.7 \text{ nF}$ L_i negligibly small
Plug-in module for analog position feedback (terminal +31 / -32)	Maximum values: $U_i = 30 \text{ V}$ $I_i = 320 \text{ mA}$ $P_i = 1.1 \text{ W}$ $C_i = 6.6 \text{ nF}$ L_i negligibly small
Plug-in module for shutdown contact input (terminal +51 / -52 or +85 / -86)	$U_i = 30 \text{ V}$ $I_i = 320 \text{ mA}$ $P_i = 1.1 \text{ W}$ $C_i = 3.7 \text{ nF}$ L_i negligibly small

Optional interface to remote sensor (terminal X2-2: +U _{ref} X3-2: GND X3-1: Signal	Maximum values: U ₀ = 5.4 V I ₀ = 74 mA P ₀ = 100 mW C _i negligibly small L _i negligibly small Ex ia or Ex ib type of ignition protection IIC: L ₀ = 5mH C ₀ = 2 μF IIB: L ₀ = 5mH C ₀ = 10 μF
Local communication interface (LKS)	Only for connection to a programmer outside the potentially explosive area. (See special conditions)

Special conditions

- The local communication interface (LKS) may only be operated at $U_m \leq 30$ V DC outside the potentially explosive area.
- Variants with special certification confirming that they meet the requirements for the "flameproof enclosure" type of ignition protection may not be used as "intrinsically safe", if they have been previously used as a flameproof type of ignition protection.
- When used with gases from group IIA and a temperature class of T1 for auxiliary power, the TZIDC positioner may only be used outdoors or inside sufficiently ventilated buildings.
- The gas supplied must be kept sufficiently free of air and oxygen to prevent an ignitable atmosphere from forming.
- The equipment may only be used as a II 2 D type device in areas where the level of mechanical hazard is "low".
- Cable and wire entries that meet the requirements of EN 61241-11 for Category II 2 D as well as the ambient temperature range must be used.
- Prevent electrostatic charging due to propagating brush discharge when the equipment is used for applications involving combustible dust.

10.1.2 ATEX Ex n

Designation:	II 3 G Ex nA IIC T6 resp. T4 Gc
Declaration of conformity:	TÜV 02 ATEX 1943 X
Type:	"n" type of protection
Device class:	II 3 G
Standards:	EN 60079-15:2010 EN 60079-0:2009

II 3 G Temperature class	Ta Ambient temperature range
T4	-40 ... 85 °C
T6	-40 ... 50 °C

Electrical data	
Signal circuit (terminal +11 / -12)	U = 9.7 V DC I = 4 ... 20 mA, max. 21.5 mA
Contact input (terminal +81 / -82)	U = 12 ... to 24 V DC; 4 mA
Switch output (terminal +83 / -84)	U = 11 V DC
Mechanical digital feedback (terminal limit1 +51 / -52 or limit2 +41 / -42)	U = 5 to 11 V DC
Plug-in module for digital position feedback (terminal +51 / -52 or +41 / -42)	U = 5 to 11 V DC
Plug-in module for analog position feedback (terminal +31 / -32)	U = 10 ... 30 V DC I = 4 ... 20 mA, max. 21.5 mA
Plug-in module for shutdown contact input (terminal +51 / -52 or +85 / -86)	U = 20 ... 30 V DC

Special conditions

- Devices may only be connected to circuits in zone 2 if they are suitable for operation in zone 2 potentially explosive atmospheres and for the conditions prevailing at the installation location (manufacturer's declaration or certificate from an inspection authority).
- For the "digital feedback with proximity switches" circuit, external measures must be implemented to prevent the rated voltage from being exceeded by more than 40 % in the event of transient disturbances.
- It is only permissible to connect, disconnect, and switch live circuits during installation or maintenance, or for the purpose of carrying out repairs. Comment: It is considered very unlikely that a potentially explosive atmosphere would be present in zone 2 at the same time that installation or maintenance/repair work was being carried out.
- Only non-flammable gases may be used for the pneumatic auxiliary power.
- Only use suitable cable entries which meet the requirements of IEC 60079-15.
- If the SJ2_S1N (NO) proximity switch is used, the positioner may only be operated at an ambient temperature range from -25 ... 85 °C.

10.1.3 IECEx

Designation: Ex ia IIC T6 or T4 Gb
 Ex ib IIC T6 or T4 Gb
 Ex nA IIC T6 or T4 Gc

Certificate No.: IECEx TUN 04.0015X

Issue No.: 5

Type: Intrinsic safety "i" or "n" type of protection

Standards: IEC 60079-0:2011
 IEC 60079-11:2011
 IEC 60079-15:2010

Type and designation	TZIDC Ex ia IIC or Ex ib IIC	
Temperature class	Ambient temperature range	
T4	-40 ... 85 °C	-40 ... 85 °C
T6 ¹⁾	-40 ... 40 °C	-40 ... 50 °C

1) When using the "digital feedback" plug-in module in temperature class T6, the maximum permissible ambient temperature range is -40 ... 35 °C.

10.1.4 IECEx i

Electrical data for a TZIDC designated as Ex ia IIC or Ex ib IIC

	With the intrinsically safe Ex ib IIC or Ex ia IIC type of ignition protection, only for connection to a certified intrinsically safe circuit.
Signal circuit (terminal +11 / -12)	Maximum values: $U_i = 30 \text{ V}$ $I_i = 320 \text{ mA}$ $P_i = 1.1 \text{ W}$ $C_i = 6.6 \text{ nF}$ L_i negligibly small
Contact input (terminal +81 / -82)	Maximum values: $U_i = 30 \text{ V}$ $I_i = 320 \text{ mA}$ $P_i = 1.1 \text{ W}$ $C_i = 4.2 \text{ nF}$ L_i negligibly small
Switch output (terminal +83 / -84)	Maximum values: $U_i = 30 \text{ V}$ $I_i = 320 \text{ mA}$ $P_i = 500 \text{ mW}$ $C_i = 4.2 \text{ nF}$ L_i negligibly small
Local communication interface (LKS)	Only for connection to a programmer outside the potentially explosive area. (See Special conditions)
The following modules may be operated as an option:	
Plug-in module for digital position feedback (terminal +51 / -52 or +41 / -42)	Maximum values: $U_i = 30 \text{ V}$ $I_i = 320 \text{ mA}$ $P_i = 500 \text{ mW}$ $C_i = 3.7 \text{ nF}$ L_i negligibly small
Plug-in module for analog position feedback (terminal +31 / -32)	Maximum values: $U_i = 30 \text{ V}$ $I_i = 320 \text{ mA}$ $P_i = 1.1 \text{ mW}$ $C_i = 6.6 \text{ nF}$ L_i negligibly small
Plug-in module for shutdown contact input (terminal +51 / -52 or +85 / -86)	Maximum values: $U_i = 30 \text{ V}$ $I_i = 320 \text{ mA}$ $P_i = 1.1 \text{ mW}$ $C_i = 3.7 \text{ nF}$ L_i negligibly small

10.1.5 IECEx n

Electrical data	
Signal circuit (terminal +11 / -12)	U = 9.7 V DC I = 4 ... 20 mA, max. 21.5 mA
Contact input (terminal +81 / -82)	U = 12 ... 24 V DC; 4 mA
Switch output (terminal +83 / -84)	U = 11 V DC
The following modules may be operated with the TZIDC as an option:	
Plug-in module for digital position feedback (terminal +51 / -52 or +41 / -42)	U = 5 ... 11 V DC
Plug-in module for analog position feedback (terminal +31 / -32)	U = 10 ... 30 V DC I = 4 ... 20 mA, max. 21.5 mA
Plug-in module for shutdown contact input (terminal +51 / -52 or +85 / -86)	U = 20 ... 30 V DC
Mechanical digital feedback (terminal limit1 +51 / -52 or limit2 +41 / -42)	U = 5 ... 11 V DC

Special conditions

- Devices may only be connected to circuits in zone 2 if they are suitable for operation in zone 2 potentially explosive atmospheres and for the conditions prevailing at the installation location (manufacturer's declaration or certificate from an inspection authority).
- For the "digital feedback with proximity switches" circuit, external measures must be implemented to prevent the rated voltage from being exceeded by more than 40 % in the event of transient disturbances.
- It is only permissible to connect, disconnect, and switch live circuits during installation or maintenance, or for the purpose of carrying out repairs. Comment: It is considered very unlikely that a potentially explosive atmosphere would be present in zone 2 at the same time that installation or maintenance/repair work was being carried out.
- Only non-flammable gases may be used for the pneumatic auxiliary power.
- Only use suitable cable entries which meet the requirements of IEC 60079-15.
- If the SJ2_S1N (NO) proximity switch is used, the positioner may only be operated at an ambient temperature range from -25 ... 85 °C.

10.1.6 CSA International

Certificate:	1052414
Class 2258 02	PROCESS CONTROL EQUIPMENT – For Hazardous Locations
Class 2258 04	PROCESS CONTROL EQUIPMENT – Intrinsically Safe, Entity – For Hazardous Locations

Class I, Div 2, Groups A, B, C and D;
Class II, Div 2, Groups E, F, and G,
Class III, Enclosure Type 4X:

Model TZIDC, P/N V18345-x0x2x2xx0x Intelligent Positioner	
Input rated	30 V DC; max. 4 ... 20 mA
Max output pressure	90 psi
Max. ambient	85 Deg C

Class I, Div 1, Groups A, B, C and D;
Class II, Div 1, Groups E, F and G
Class III, Enclosure Type 4X:

Model TZIDC, P/N V18345-x0x2x2xx0x Intelligent Positioner intrinsically safe with entity parameters of:	
Terminals 11 / 12	V max = 30 V I max = 104 mA C _i = 6.6 nF L _i = 0 uH
Terminals 81 / 82	V max = 30 V I max = 110 mA C _i = 4.2 nF L _i = 0 uH
Terminals 83 / 84	V max = 30 V I max = 90 mA C _i = 4.2 nF L _i = 0 uH
Terminals 31 / 32	V max = 30 V I max = 110 mA C _i = 6.6 nF L _i = 0 uH
Terminals 41 / 42 and 51 / 52	V max = 30 V I max = 96 mA C _i = 3.7 nF L _i = 0 uH
Terminals Limit2 41 / 42 and Limit1 51 / 52	V max = 15.5 V I max = 52 mA C _i = 20 nF L _i = 30 uH

When installed per installation Drawing No 901064	
Temperature Code	T4
Max. Ambient	85 Deg C



IMPORTANT (NOTE)

- The "x" in P/N denotes minor mechanical variations or optional features.
- Do not use the local communication interface (LKS) in hazardous areas.
- Each pair of conductors for each intrinsic safety circuit must be shielded.

10.1.7 CSA Certification Record

Certificate:
Class 2258 04

1649904 (LR 20312)
PROCESS CONTROL EQUIPMENT –
Intrinsically Safe, Entity – For Hazardous
Locations

Class I, Div 1, Groups A, B, C and D;
Class II, Div 1, Groups E, F, and G,
Class III, Div 1, Enclosure Type 4X:

Model TZIDC, P/N V18345-x0x2x2xx0x Intelligent Positioner	
Input rated	30 V DC; max.4 ... 20 mA
Output pressure	Max. 90 psi
Intrinsically safe with entity parameters of:	
Terminals 11 / 12	V max = 30 V I max = 104 mA C _i = 6.6 nF L _i = 0 uH
Terminals 81 / 82	V max = 30 V I max = 110 mA C _i = 3.7 nF L _i = 0 uH
Terminals 83 / 84	V max = 30 V I max = 96 mA C _i = 3.7 nF L _i = 0 uH
Terminals 31 / 32	V max = 30 V I max = 110 mA C _i = 6.6 nF L _i = 0 uH
Terminals 41 / 42 and 51 / 52	V max = 30 V I max = 96 mA C _i = 3.7 nF L _i = 0 uH
Terminals Limit2 41 / 42 and Limit1 51 / 52	V max = 15.5 V I max = 52 mA C _i = 20 nF L _i = 30 uH

When installed per installation Drawing No 901064	
Temperature Code	T4
Max. Ambient	85 Deg C



IMPORTANT (NOTE)

- The "x" in P/N denotes minor mechanical variations or optional features.
- Do not use the local communication interface (LKS) in hazardous areas.
- Each pair of conductors for each intrinsic safety circuit must be shielded.

10.1.8 FM Approvals

TZIDC Positioner, Model V18345-a0b2c2de0f

IS/I,II,III/1/ABCDEFG/T4 Ta = 85 °C – 901064/7/4; Enity; NI/I/2/ABCD/T4 Ta = 85 °C;

S/II,III/2/FG/T4 Ta =85 °C; Type 4XMax Enity Parameters: Per Control Drawings

a = Case/mounting – 1, 2, 3, 4 or 9

b = Input/communication port – 1 or 2

c = Output/safe protection – 1, 2, 4 or 5

d = Option modules for analog or digital position feedback – 0, 1, 3 or 5

e = Mechanical kit (proximity swiches) for digital position feedback (option) – 0, 1 or 3

f = Design (varnish/coding) – 1 or 2

CONTROL DOCUMENT NO 901064

Hazardous area

Nonhazardous area

Class I, Div. I, Groups A, B, C, D
 Class II, Div. I, Groups E, F, G
 Class III, Div. I
 (Note 2)

TZIDC
 VI8345-X0X2X2XX0X

Associated Apparatus

Control Equipment

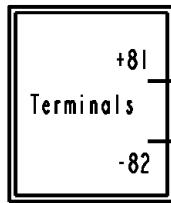

(Switching Input)

Entity Parameters:

$V_{max} = 30 \text{ Vdc}$ $I_{max} = 110 \text{ mA}$
 $C_i = 4.2 \text{ nF}$ $L_i = 0 \text{ }\mu\text{H}$
 $P_i = 1 \text{ W}$

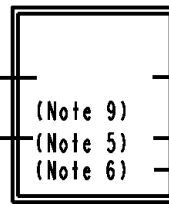

Int. Safe Gnd

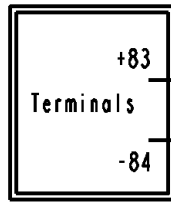
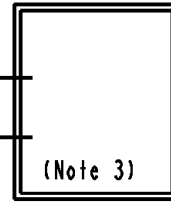

(Switching Output)

Entity Parameters:

$V_{max} = 30 \text{ Vdc}$ $I_{max} = 96 \text{ mA}$
 $C_i = 4.2 \text{ nF}$ $L_i = 0 \text{ }\mu\text{H}$
 $P_i = 1 \text{ W}$

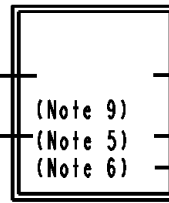

Int. Safe Gnd

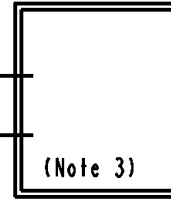

Copyright reserved
 This drawing is the property of ABB.
 Neither the drawing, nor reproductions of it
 nor information derived from it is to be given to others.
 No use is to be made by any third party without the written
 permission of ABB.

				All Dimensions in mm		Title CONTROL_DOCUMENT	Scale	
				Date				Name
				Drawn 08-Apr-99				Lasarzik
				Checked		Drawing No. (Part No) 901064	Sheet 2 / 4	
				ABB Automation				Replacement for:
10	-	05.10.09	Lasarzik					-
Rev.	Amendment	Date	Name					

CONTROL DOCUMENT NO 901064

Hazardous area

Nonhazardous area

Class I, Div. I, Groups A, B, C, D
 Class II, Div. I, Groups E, F, G
 Class III, Div. I
 (Note 2)

TZIDC
 VI8345-X0X2X21X0X

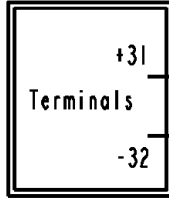

(Analog Position Feedback)

Entity Parameters:

$V_{max} = 30 \text{ Vdc}$ $I_{max} = 110 \text{ mA}$
 $C_i = 6.6 \text{ nF}$ $L_i = 0 \text{ }\mu\text{H}$
 $P_i = 1 \text{ W}$

TZIDC
 VI8345-X0X2X23X0X

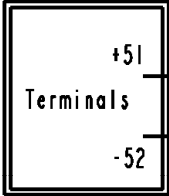

(Digital Position Feedback)

Entity Parameters:

$V_{max} = 30 \text{ Vdc}$ $I_{max} = 96 \text{ mA}$
 $C_i = 3.7 \text{ nF}$ $L_i = 0 \text{ }\mu\text{H}$ $P_i = 1 \text{ W}$

Associated Apparatus

Control Equipment

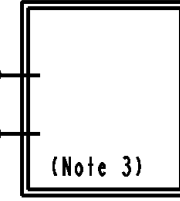
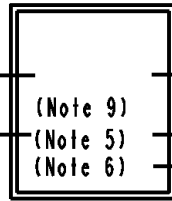

Int. Safe Gnd

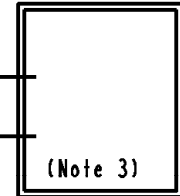
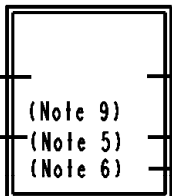

Int. Safe Gnd

Copyright reserved
 This drawing is the property of ABB.
 Neither the drawing, nor reproductions of it
 nor information derived from it is to be given to others.
 No use is to be made by others without the written
 permission of ABB.

				All Dimensions in mm		Title CONTROL_DOCUMENT	Scale	
				Date				Name
				Drawn 08-Apr-99				Lasarzik
				Checked				
						Drawing No. (Part No)	Sheet	
						901064		3/4
10	-	05.10.09	Lasarzik	Replacement for: -		Category: -		
Rev.	Amendment	Date	Name	ABB Automation				

CONTROL DOCUMENT NO 901064

Hazardous area

Nonhazardous area

Class I, Div. 1, Groups A, B, C, D
 Class II, Div. 1, Groups E, F, G
 Class III, Div. 1
 (Note 2)

TZIDC
 VI8345-X0X2X2X10X
 or VI8345-X0X2X2X30X

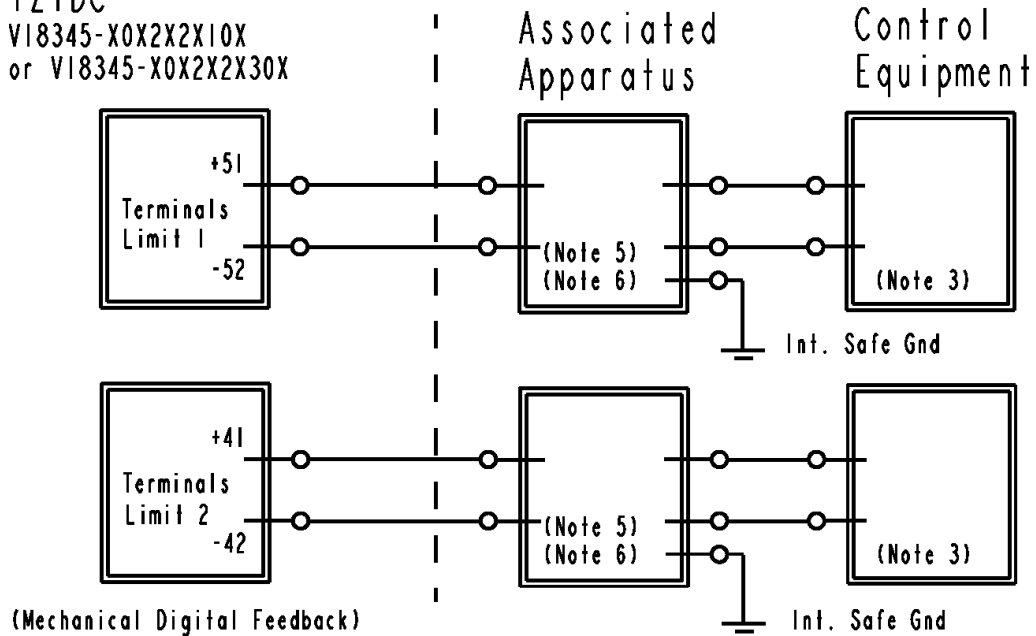

Entity Parameters:
 Vmax = 15.5 V
 Imax = 52 mA
 Ci = 20 nF
 Li = 30 µH
 Pi = 1 W

Copyright reserved
 This drawing is the property of ABB.
 Neither the drawing, nor reproductions of it
 nor information derived from it is to be given to others.
 No use is to be made injurious to ABB

				All Dimensions in mm		Title CONTROL_DOCUMENT	Scale	
				Date				Name
				Drawn 08-Apr-99				Lasarzik
				Checked				
				ABB ABB Automation		Drawing No. (Part No)	Sheet	
						901064		4 / 4
10	-	05.10.09	Lasarzik	Replacement for: -			Category: -	

10.2 TZIDC-110

10.2.1 ATEX Ex i

Designation: II 2 G Ex ia IIC T6 resp. T4 Gb
 II 3 G Ex ic IIC T6 resp. T4 Gc
 Type Examination Test Certificate: TÜV 02 ATEX 1831 X
 Type: Intrinsically safe equipment
 Standards: EN 60079-0:2009
 EN 60079-11:2007
 EN 60079-27:2008

Temperature class	Ambient temperature range
T4	-40 ... 85 °C
T6	-40 ... 40 °C

Electrical data for ia/ib/ic for groups IIB/IIC

	With the intrinsically safe Ex i IIC type of ignition protection, only for connection to a certified FISCO power supply unit, a barrier, or a power supply unit with linear characteristics and the following maximum values:
Signal circuit (terminal +11 / -12 or + / -)	U _i = 24 V I _i = 250 mA P _i = 1.2 W Characteristic curve: linear L _i < 10 µH C _i < 5 nF

	With the intrinsically safe Ex i IIC type of ignition protection, only for connection to a certified intrinsically safe circuit with maximum values
Shutdown contact input (terminal +85 / -86)	U _i = 30 V C _i = 3.7 nF L _i negligibly small
Mechanical digital feedback (terminal limit1 +51 / -52 or limit2 +41 / -42)	For max. values, see EC type examination test certificate number PTB 00 ATEX 2049 X

10.2.2 ATEX Ex n

Designation:	II 3 G Ex nA IIC T6 resp. T4 Gc
Declaration of conformity:	TÜV 02 ATEX 1943 X
Type:	"n" type of protection
Device class:	II 3 G
Standards:	EN 60079-15:2010 EN 60079-0:2009

II 3 G Temperature class	Ta Ambient temperature range
T4	-40 ... 85 °C
T6	-40 ... 50 °C

Electrical data for II 3 G Ex nA IIC T6 or T4 Gc	
Signal circuit (terminal +11 / -12)	U = 9 to 32 V DC I = 10.5 mA
Mechanical digital feedback (terminal limit1 +51 / -52 or limit2 +41 / -42)	U = 5 ... 11 V DC
Plug-in module for shutdown contact input (terminal +51 / -52 or +85 / -86)	U = 20 ... 30 V DC

Special conditions

- Devices may only be connected to circuits in zone 2 if they are suitable for operation in zone 2 potentially explosive atmospheres and for the conditions prevailing at the installation location (manufacturer's declaration or certificate from an inspection authority).
- For the "digital feedback with proximity switches" circuit, external measures must be implemented to prevent the rated voltage from being exceeded by more than 40 % in the event of transient disturbances.
- It is only permissible to connect, disconnect, and switch live circuits during installation or maintenance, or for the purpose of carrying out repairs. Comment: It is considered very unlikely that a potentially explosive atmosphere would be present in zone 2 at the same time that installation or maintenance/repair work was being carried out.
- Only non-flammable gases may be used for the pneumatic auxiliary power.
- Only use suitable cable entries which meet the requirements of IEC 60079-15.
- If the SJ2_S1N (NO) proximity switch is used, the positioner may only be operated at an ambient temperature range from -25 ... 85 °C.

10.2.3 IECEx

Designation:	Ex ia IIC T6 resp. T4 Gb Ex ib IIC T6 resp. T4 Gb Ex ic IIC T6 resp. T4 Gc Ex nA IIC T6 resp. T4 Gc
Certificate No.	IECEx TUN 04.0015X
Issue No.:	5
Type:	Intrinsic safety "i" or Type of protection "n"
Standards:	IEC 60079-0:2011 IEC 60079-11:2011 IEC 60079-15:2010

Type and designation	TZIDC-110 Ex i IIC	TZIDC-110 Ex nA IIC
Temperature class	Ambient temperature range	
T4	-40 ... 85 °C	-40 ... 85 °C
T6	-40 ... 40 °C	-40 ... 50 °C

10.2.4 IECEx i

Electrical data for TZIDC-110 for ia/ib/ic designated as Ex i IIC T6 or T4 Gb

	With the intrinsically safe Ex i IIC type of ignition protection, only for connection to a certified FISCO power supply unit, a barrier, or a power supply unit with linear characteristics and the following maximum values:
Signal circuit (terminal +11 / -12 or + / -)	U _i = 24 V I _i = 250 mA P _i = 1.2 W Characteristic curve: linear

The following modules may be used as an option: Ex nA IIC T6 or T4 Gc:

	With the intrinsically safe Ex ia IIC or Ex ib type of ignition protection, only for connection to a certified intrinsically safe circuit with maximum values
Shutdown contact input (terminals: +51, -52 or +85 / -86)	U _i = 30 V I _i = 320 mA P _i = 1.1 W C _i = 3.7 nF L _i negligibly small

10.2.5 IECEx n

Electrical data for TZIDC-110 designated as Ex nA IIC T6 or T4 Gc	
Signal circuit (terminal +11 / -12)	U = 9 ... 32 V DC I = 10.5 mA
Mechanical digital feedback (terminal limit1 +51 / -52 or limit2 +41 / -42)	U = 5 ... 11 V DC
Plug-in module for shutdown contact input (terminal +51 / -52 or +85 / -86)	U = 20 ... 30 V DC

Special conditions

- Devices may only be connected to circuits in zone 2 if they are suitable for operation in zone 2 potentially explosive atmospheres and for the conditions prevailing at the installation location (manufacturer's declaration or certificate from an inspection authority).
- For the "digital feedback with proximity switches" circuit, external measures must be implemented to prevent the rated voltage from being exceeded by more than 40 % in the event of transient disturbances.
- It is only permissible to connect, disconnect, and switch live circuits during installation or maintenance, or for the purpose of carrying out repairs. Comment: It is considered very unlikely that a potentially explosive atmosphere would be present in zone 2 at the same time that installation or maintenance/repair work was being carried out.
- Only non-flammable gases may be used for the pneumatic auxiliary power.
- Only use suitable cable entries which meet the requirements of IEC 60079-15.
- If the SJ2_S1N (NO) proximity switch is used, the positioner may only be operated at an ambient temperature range from -25 ... 85 °C.

10.2.6 CSA International

Certificate:	1649904 (LR 20312)
Class 2258 04	PROCESS CONTROL EQUIPMENT – Intrinsically Safe, Entity – For Hazardous Locations
Class 2258 02	PROCESS CONTROL EQUIPMENT – For Hazardous Locations

Class I, Div 2, Groups A, B, C and D;
Class II, Div 2, Groups E, F, and G,
Class III, Enclosure Type 4X:

Model TZIDC-110, P/N V18346-x032x2xx0x Intelligent Positioner	
Input rated	32 V DC; max. 15 mA (powered by a SELV circuit)
Intrinsically safe with entity parameters of:	
Terminals 11 / 12	V max = 24 V I max = 250 mA C _i = 2.8 nF L _i = 7.2 uH
Terminals 85 / 86	U max = 30 V I max = 50 mA C _i = 3.8 nF L _i = 0 uH
Terminals 41 / 42	U max = 16 V I max = 20 mA C _i = 60 nF L _i = 100 uH
Terminals 51 / 52	U max = 16 V I max = 20 mA C _i = 60 nF L _i = 100 uH

When installed per installation Drawing No 901265	
Temperature Code	T4
Max. Ambient	85 Deg C



IMPORTANT (NOTE)

- The "x" in P/N denotes minor mechanical variations or optional features.
- Do not use the local communication interface (LKS) in hazardous areas.
- Each pair of conductors for each intrinsic safety circuit must be shielded.

10.2.7 CSA Certification Record

Certificate:	1649904 (LR 20312)
Class 2258 04	PROCESS CONTROL EQUIPMENT – Intrinsically Safe, Entity – For Hazardous Locations

Class I, Div 1, Groups A, B, C and D;
Class II, Div 1, Groups E, F, and G,
Class III, Div 1, Enclosure Type 4X:

Model TZIDC-110, P/N V18346-x032x2xx0x Intelligent Positioner	
Input rated	32 V DC; max. 15 mA (powered by a SELV Circuit)
Intrinsically safe with entity parameters of:	
Terminals 11 / 12	V max = 24 V I max = 250 mA C _i = 2.8 nF L _i = 7.2 uH
Terminals 85 / 86	U max = 30 V I max = 50 mA C _i = 3.8 nF L _i = 0 uH
Terminals 41 / 42	U max = 16 V I max = 20 mA C _i = 60 nF L _i = 100 uH

When installed per installation Drawing No 901265	
Temperature Code	T4
Max. Ambient	85 Deg C



Notice

- The "x" in P/N denotes minor mechanical variations or optional features.
- Do not use the local communication interface (LKS) in hazardous areas.
- Each pair of conductors for each intrinsic safety circuit must be shielded.

10.2.8 FM Approvals

TZIDC-110 Positioner, Model V18346-a032b2cd0e

IS/I,II,III/1/ABCDEFG/T6,T5,T4 Ta = 40 °C, 55 °C, 85 °C-901265 Entity, FISCO

Entity and FISCO Parameters							
Terminals	Type	Groups	Parameters				
			Vmax	I _{max}	P _i	C _i	L _i
+11 / -12	Entity	A-G	24 V	250 mA	1.2 W	2.8 nF	7.2 uH
+11 / -12	FISCO	A-G	17.5 V	360 mA	2.52 W	2.8 nF	7.2 uH
+11 / -12	FISCO	C-G	17.5 V	380 mA	5.32 W	2.8 nF	7.2 uH
+51 / -52	Entity	A-G	16 V	20 mA	-	60 nF	100 uH
+41 / -42	Entity	A-G	16 V	20 mA	-	60 nF	100 uH
+85 / -86	Entity	A-G	30 V	-	-	3.7 nF	< 1 uH

NI/II/2/ABCD/T6,T5,T4 Ta = 40 °C, 55 °C, 85 °C

S/II,III/2/EF/II/T6,T5,T4 Ta = 40 °C, 55 °C, 85 °C

Enclosure type 4x

a = Case/mounting – 1, 2, 5 or 6

b = Output/safe protection – 1, 2, 4 or 5

c = Option modules (shutdown) – 0 or 4

d = Optional mechanical kit for digital position feedback – 0, 1 or 3

e = Design (varnish/coding) – 1 or E

Equipment Ratings:

TZIDC-110

Intrinsically safe, Entity and FISCO, for Class I, II and III, Division 1,

Applicable Groups A, B, C, D, E, F, G; nonincendive for Class I, Division 2,

Group E, F and G hazardous (classified) indoor and outdoor NEMA 4x locations.

The following temperature code ratings were assigned for the equipment and protection methods described above:
T6 in ambient temperatures of 40 °C
T5 in ambient temperatures of 55 °C
T4 in ambient temperatures of 85 °C

Ex relevant specifications

10.2.9 FM Control Document

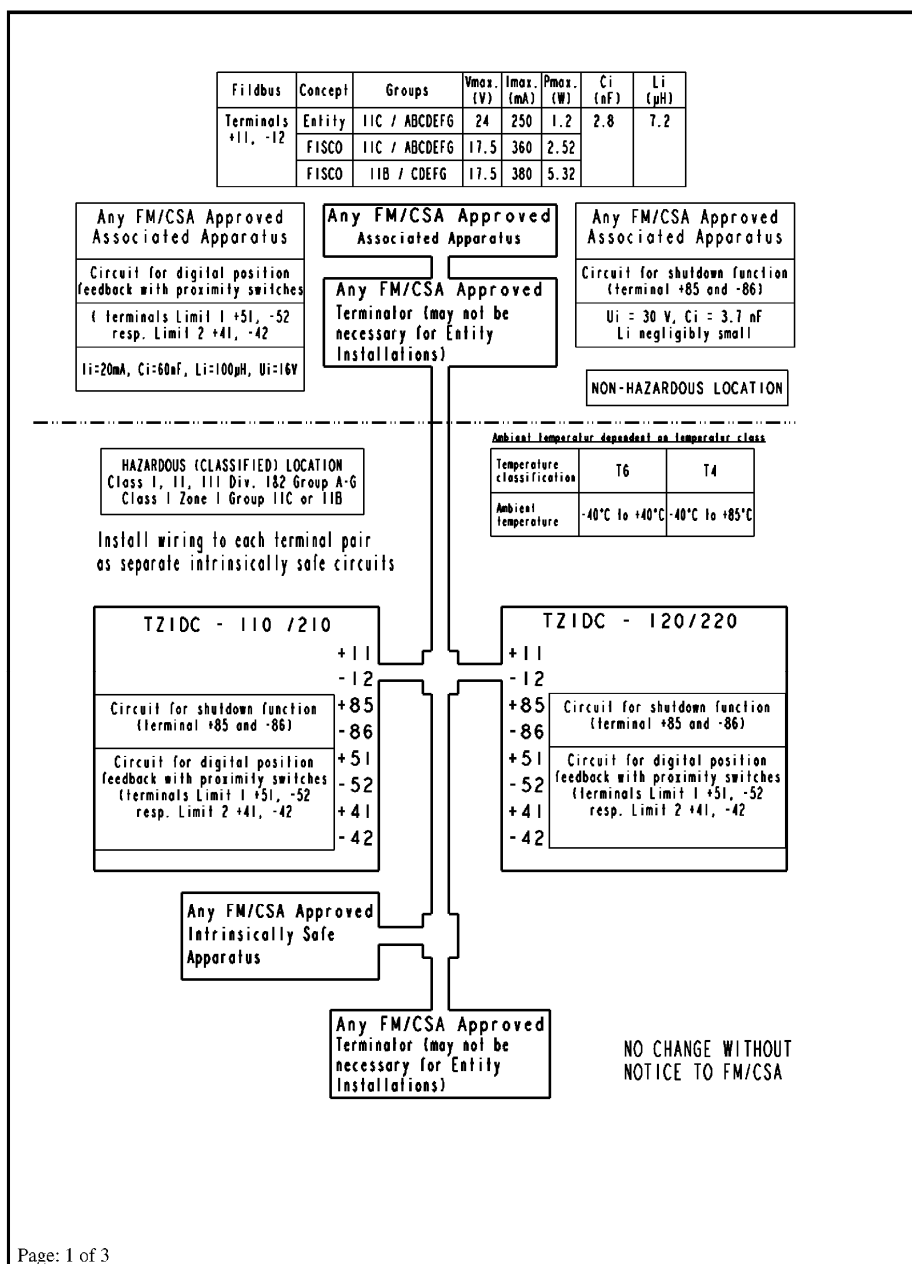

Page: 1 of 3

Rev.	Chang	Date	Name	2003	Date	Name	Title	Scale
-	-							
				Name	27.03.03	Thiem.	FM/CSA-Control-Document	
				Appr.				
				Std.				
3	Rev.2	26.06.06	Thie.	ABB		Automation Products		Drwg.-No. (Part-No.)
2	Rev.1	22.05.06	Thie.					901265
1	Rev.0	27.03.	Thie.					
Rev.	Chang	Date	Name			Supersedes Dwg. :	Part Class:	

Page: 2 of 3				FM/CSA-CONTROL-DOCUMENT_901265				
<p>FISCO rules</p> <p>The FISCO Concept allows the interconnection of intrinsically safe apparatus to associated apparatus not specifically examined in such combination. The criterion for such interconnection is that the voltage (V_{max}), the current (I_{max}) and the power (P_i) which intrinsically safe apparatus can receive and remain intrinsically safe, considering faults, must be equal or greater than the voltage (U_o, V_o, V_t), the current (I_o, I_{sc}, I_t) and the power (P_o) which can be provided by the associated apparatus (supply unit). In addition, the maximum unprotected residual capacitance (C_i) and inductance (L_i) of each apparatus (other than the terminators) connected to the Fieldbus must be less than or equal to 5nF and 10 μH respectively.</p> <p>In each I.S. Fieldbus segment only one active source, normally the associated apparatus, is allowed to provide the necessary power for the Fieldbus system. The allowed voltage (U_o, V_o, V_t) of the associated apparatus used to supply the bus must be limited to the range of 14V d.c. to 24V d.c. All other equipment connected to the bus cable has to be passive, meaning that the apparatus is not allowed to provide energy to the system, except to a leakage current of 50 μA for each connected device. Separately powered equipment needs a galvanic Isolation to insure that the intrinsically safe Fieldbus circuit remains passive.</p> <p>The cable used to interconnect the devices needs to comply with the following parameters:</p> <p>Loop resistance R': 15...150 Ω/km Inductance per unit length L': 0.4...1mH/km Capacitance per unit length C': 80...200 nF / km $C' = C'$ line/line + 0.5C' line/screen, if both lines are floating or $C' = C'$ line/line + C' Line/screen, if the screen is connected to one line Length of spur cable: max. 30m Length of trunk cable: max. 1km Length of splice: max. 1m</p> <p>Terminators</p> <p>At each end of the trunk cable an approved line terminator with the following parameters is suitable: $R = 90...100 \Omega$ $C = 0...2.2 \mu F$.</p> <p>System evaluation</p> <p>The number of passive devices like transmitters, actuators, connected to a single bus segment is not limited due to I.S. Reasons. Furthermore, if the above rules are respected, the inductance and capacitance of the cable need not to be considered and will not impair the intrinsic safety of the installation.</p>								
-	-			2003	Date	Name	Title	Scale
				Name	27.03.03	Thiem.	FM/CSA-Control-Document	/
				Appr.				
				Std.				
3	Rev.2	26.06.06	Thie.	ABB			Drwg.-No. (Part-No.)	
2	Rev.1	22.05.06	Thie.	Automation Products			901265	
1	Rev.0	27.03.	Thie.					
Rev.	Chang	Date	Name				Supersedes Dwg. :	Part Class:

Page: 3 of 3								
FM/CSA-CONTROL-DOCUMENT_901265								
<p>Installation Notes For FISCO and Entity Concepts:</p> <ol style="list-style-type: none"> 1. The Intrinsic Safety Entity concept allows the interconnection of FM/CSA Approved Intrinsically safe devices with entity parameters not specifically examined in combination as a system when: U_o or V_{oc} or $V_t \leq V_{max}$, I_o or I_{sc} or $I_t \leq I_{max}$, $P_o \leq P_i$. C_a or $C_o \geq \sum C_i + \sum C_{cable}$. For inductance use either L_a or $L_o \geq \sum L_i + \sum L_{cable}$ or $L_c / R_c \leq (L_a / R_a \text{ or } L_o / R_o)$ and $L_i / R_i \leq (L_a / R_a \text{ or } L_o / R_o)$ 2. The Intrinsic Safety FISCO concept allows the interconnecting of FM/CSA Approved Intrinsically safe devices with FISCO parameters not specifically examine in combination as a system when: U_o or V_{oc} or $V_t \leq V_{max}$, I_o or I_{sc} or $I_t \leq I_{max}$, $P_o \leq P_i$. 3. Control equipment connected to the Associated Apparatus must not use or generate more than 250 Vrms or Vdc. 4. Installation should be in accordance with ANSI/ISA RP12.6 (except chapter 5 for FISCO Installations) "Installation of Intrinsically Safe System for Hazardous (Classified) Locations" and the National Electrical Code® (ANSI/NFPA 70) Sections 504 and 505. 5. The configuration of associated Apparatus must be Factory Mutual Research /Canadian Standards Association Approved under the associated concept. 6. Associated Apparatus manufacturer's installation drawing must be followed when installing this equipment. 7. No revision to drawing without prior Factory Mutual Research Approval/Canadian Standards Association. 8. Special conditions for safe use The operation of the local communication interface (LKS) and of the programming interface (X5) is only allowed outside of the Hazardous explosive area. <p>NONINCENDIVE, CLASS I, DIV. 2, GROUP A, B, C, D, AND FOR CLASS II AND III, DIV. 1&2, GROUP E, F, G HAZARDOUS LOCATION INSTALLATION.</p> <ol style="list-style-type: none"> 1. Install per National Electrical Code (NEC) using threaded metal conduit. Intrinsic safety barrier required. Max. Supply voltage 30 V. For T-code see table. 2. A dust tight seal must be used at the conduit entry when the positioner is used in a Class II & III Location. 3. WARNING: Explosion Hazard – do not disconnect equipment unless power has been switched off or the area is known to be Non-Hazardous. WARNING: Substitution of components may impair suitability for hazardous locations. 								
-	-			2003	Date	Name	Title	Scale
					27.03.03	Thiem.	FM/CSA-Control-Document	/
3	Rev.2	26.06.06	Thie.				Drwg.-No. (Part-No.)	
2	Rev.1	22.05.06	Thie.	Automation Products			901265	
1	Rev.0	27.03.	Thie.					
Rev.	Chang	Date	Name				Supersedes Dwg. :	Part Class:

10.3 TZIDC-120

10.3.1 ATEX Ex i

Designation: II 2 G Ex ia IIC T6 resp. T4 Gb
 II 3 G Ex ic IIC T6 resp. T4 Gc
 Type Examination Test Certificate: TÜV 02 ATEX 1834 X
 Type: Intrinsically safe equipment
 Standards: EN 60079-0:2009
 EN 60079-11:2007
 EN 60079-27:2008

Temperature class	Ambient temperature range
T4	-40 ... 85 °C
T5	-40 ... 55 °C
T6	-40 ... 40 °C

Electrical data for ia/ib/ic for groups IIB/IIC

	With the intrinsically safe Ex i IIC type of ignition protection, only for connection to a certified FISCO power supply unit, a barrier, or a power supply unit with linear characteristics and the following maximum values:
Signal circuit (terminal +11 / -12 or + / -)	U _i = 24 V I _i = 250 mA P _i = 1.2 W Characteristic curve: linear L _i < 10 µH C _i < 5 nF

	With the intrinsically safe Ex ia IIC or Ex ib IIC type of ignition protection, only for connection to a certified intrinsically-safe circuit with maximum values
Shutdown contact input (terminal +85 / -86)	U _i = 30 V C _i = 3.7 nF L _i negligibly small
Mechanical digital feedback (terminal limit1 +51 / -52 or limit2 +41 / -42)	For maximum values, see EC type examination test certificate number PTB 00 ATEX 2049 X

Ex relevant specifications

10.3.2 ATEX Ex n

Designation:	II 3 G Ex nA IIC T6 resp. T4 Gc
Declaration of conformity:	TÜV 02 ATEX 1943 X
Type:	Type of ignition protection "n"
Device class:	II 3 G
Standards:	EN 60079-15:2010 EN 60079-0:2009

II 3 G Temperature class	Ta Ambient temperature range
T4	-40 ... 85 °C
T6	-40 ... 50 °C

Electrical data for II 3 G Ex nA IIC T6 or T4 Gc	
Signal circuit (terminal +11 / -12)	U = 9 ... 32 V DC I = 11.5 mA
Mechanical digital feedback (terminal limit1 +51 / -52 or limit2 +41 / -42)	U = 5 ... 11 V DC
Plug-in module for shutdown contact input (terminal+51 / -52 or +85 / -86)	U = 20 ... 30 V DC

Special conditions

- Devices may only be connected to circuits in zone 2 if they are suitable for operation in zone 2 potentially explosive atmospheres and for the conditions prevailing at the installation location (manufacturer's declaration or certificate from an inspection authority).
- For the "digital feedback with proximity switches" circuit, external measures must be implemented to prevent the rated voltage from being exceeded by more than 40 % in the event of transient disturbances.
- It is only permissible to connect, disconnect, and switch live circuits during installation or maintenance, or for the purpose of carrying out repairs. Comment: It is considered very unlikely that a potentially explosive atmosphere would be present in zone 2 at the same time that installation or maintenance/repair work was being carried out.
- Only non-flammable gases may be used for the pneumatic auxiliary power.
- Only use suitable cable entries which meet the requirements of IEC 60079-15.
- If the SJ2_S1N (NO) proximity switch is used, the positioner may only be operated at an ambient temperature range from -25 ... 85 °C.

10.3.3 IECEx

Designation:	Ex ia IIC T6 or T4 Gb Ex ib IIC T6 or T4 Gb Ex ic IIC T6 or T4 Gc Ex nA IIC T6 or T4 Gc
Certificate No.:	IECEx TUN 04.0015X
Issue No.:	5
Type:	Intrinsic safety "i" or "n" type of protection
Standards:	IEC 60079-0:2011 IEC 60079-11:2011 IEC 60079-15:2010

Type and designation	TZIDC-120 Ex i IIC	TZIDC-120 Ex nA IIC
Temperature class	Ambient temperature range	
T4	-40 ... 85 °C	-40 ... 85 °C
T6	-40 ... 40 °C	-40 ... 50 °C

10.3.4 IECEx i

Electrical data for TZIDC-110 for ia/ib/ic designated as Ex i IIC T6 or T4 Gb

	With the intrinsically safe Ex i IIC type of ignition protection, only for connection to a certified FISCO power supply unit, a barrier, or a power supply unit with linear characteristics and the following maximum values:
Signal circuit (terminal +11 / -12 or + / -)	U _i = 24 V I _i = 250 mA P _i = 1.2 W Characteristic curve: linear

The following modules may be used as an option: Ex nA IIC T6 or T4 Gc

	With the intrinsically safe Ex ia IIC or Ex ib type of ignition protection, only for connection to a certified intrinsically safe circuit with maximum values:
Shutdown contact input (terminals: +51,-52 or +85 / -86)	U _i = 30 V I _i = 320 mA P _i = 1.1 W C _i = 3.7 nF L _i negligibly small

Ex relevant specifications

10.3.5 IECEx n

Electrical data for TZIDC-120 designated as Ex nA IIC T6 or T4 Gc	
Signal circuit (terminal +11 / -12)	U = 9 ... 32 V DC I = 11.5 mA
Mechanical digital feedback (terminal limit1 +51 / -52 or limit2 +41 / -42)	U = 5 to 11 V DC
Plug-in module for shutdown contact input (terminal +51 / -52 or +85 / -86)	U = 20 ... 30 V DC

Special conditions

- Devices may only be connected to circuits in zone 2 if they are suitable for operation in zone 2 potentially explosive atmospheres and for the conditions prevailing at the installation location (manufacturer's declaration or certificate from an inspection authority).
- For the "digital feedback with proximity switches" circuit, external measures must be implemented to prevent the rated voltage from being exceeded by more than 40 % in the event of transient disturbances.
- It is only permissible to connect, disconnect, and switch live circuits during installation or maintenance, or for the purpose of carrying out repairs. Comment: It is considered very unlikely that a potentially explosive atmosphere would be present in zone 2 at the same time that installation or maintenance/repair work was being carried out.
- Only non-flammable gases may be used for the pneumatic auxiliary power.
- Only use suitable cable entries which meet the requirements of IEC 60079-15.
- If the SJ2_S1N (NO) proximity switch is used, the positioner may only be operated at an ambient temperature range from -25 ... 85 °C.

10.3.6 CSA International

Certificate:	1649904 (LR 20312)
Class 2258 04	PROCESS CONTROL EQUIPMENT – Intrinsically Safe, Entity – For Hazardous Locations
Class 2258 02	PROCESS CONTROL EQUIPMENT – For Hazardous Locations

Class I, Div 2, Groups A, B, C and D;
Class II, Div 2, Groups E, F, and G,
Class III, Enclosure Type 4X:

Model TZIDC-120, P/N V18347-x042x2xx0x Intelligent Positioner	
Input rated	32 V DC; max. 15 mA (powered by a SELV circuit)
Intrinsically safe with entity parameters of:	
Terminals 11 / 12	V max = 24 V I max = 250 mA C _i = 2.8 nF L _i = 7.2 uH
Terminals 85 / 86	U max = 30 V I max = 50 mA C _i = 3.8 nF L _i = 0 uH
Terminals 41 / 42	U max = 16 V I max = 20 mA C _i = 60 nF L _i = 100 uH
Terminals 51 / 52	U max = 16 V I max = 20 mA C _i = 60 nF L _i = 100 uH

When installed per installation Drawing No 901265	
Temperature Code	T4
Max. Ambient	85 Deg C



IMPORTANT (NOTE)

- The "x" in P/N denotes minor mechanical variations or optional features.
- Do not use the local communication interface (LKS) in hazardous areas.
- Each pair of conductors for each intrinsic safety circuit must be shielded.

10.3.7 CSA Certification Record

Certificate: 1649904 (LR 20312)
 Class 2258 04 PROCESS CONTROL EQUIPMENT –
 Intrinsically Safe, Entity – For Hazardous
 Locations

Class I, Div 1, Groups A, B, C and D;
 Class II, Div 1, Groups E, F, and G,
 Class III, Div 1, Enclosure Type 4X:

Model TZIDC-120, P/N V18347-x042x2xx0x Intelligent Positioner	
Input rated	32 V DC; max. 15 mA (powered by a SELV Circuit)
Intrinsically safe with entity parameters of:	
Terminals 11 / 12	V max = 24 V I max = 250 mA C _i = 2.8 nF L _i = 7.2 uH
Terminals 85 / 86	U max = 30 V I max = 50 mA C _i = 3.8 nF L _i = 0 uH
Terminals 41 / 42	U max = 16 V I max = 20 mA C _i = 60 nF L _i = 100 uH

When installed per installation Drawing No 901265	
Temperature Code	T4
Max. Ambient	85 Deg C



IMPORTANT (NOTE)

- The "x" in P/N denotes minor mechanical variations or optional features.
- Do not use the local communication interface (LKS) in hazardous areas.
- Each pair of conductors for each intrinsic safety circuit must be shielded.

10.3.8 FM Approvals

TZIDC-120 Positioner, Model V18347-a042b2cd0e

IS/I,II,III/1/ABCDEFG/T6,T5,T4 Ta = 40 °C, 55 °C, 85 °C-901265 Entity, FISCO

Entity and FISCO Parameters							
Terminals	Type	Groups	Parameters				
			Vmax	I _{max}	Pi	Ci	Li
+11 / -12	Entity	A-G	24 V	250 mA	1.2 W	2.8 nF	7.2 uH
+11 / -12	FISCO	A-G	17.5 V	360 mA	2.52 W	2.8 nF	7.2 uH
+11 / -12	FISCO	C-G	17.5 V	380 mA	5.32 W	2.8 nF	7.2 uH
+51 / -52	Entity	A-G	16 V	20 mA	-	60 nF	100 uH
+41 / -42	Entity	A-G	16 V	20 mA	-	60 nF	100 uH
+85 / -86	Entity	A-G	30 V	-	-	3.7 nF	< 1 uH

NI/II/2/ABCD/T6,T5,T4 Ta = 40 °C, 55 °C, 85 °C

S/II,III/2/EF/II/T6,T5,T4 Ta = 40 °C, 55 °C, 85 °C

Enclosure type 4x

a = Case/mounting – 1, 2, 5 or 6

b = Output/safe protection – 1, 2, 4 or 5

c = Option modules (shutdown) – 0 or 4

d = Optional mechanical kit for digital position feedback – 0, 1 or 3

e = Design (varnish/coding) – 1 or E

Equipment Ratings:

TZIDC-120 Positioners

Intrinsically safe, Entity and FISCO, for Class I, II and III, Division 1,

Applicable Groups A, B, C, D, E, F, G; nonincendive for Class I, Division 2,

Group E, F and G hazardous (classified) indoor and outdoor NEMA 4x locations.

The following temperature code ratings were assigned for the equipment and protection methods described above:
T6 in ambient temperatures of 40 °C
T5 in ambient temperatures of 55 °C
T4 in ambient temperatures of 85 °C

Ex relevant specifications

10.3.9 FM Control Document

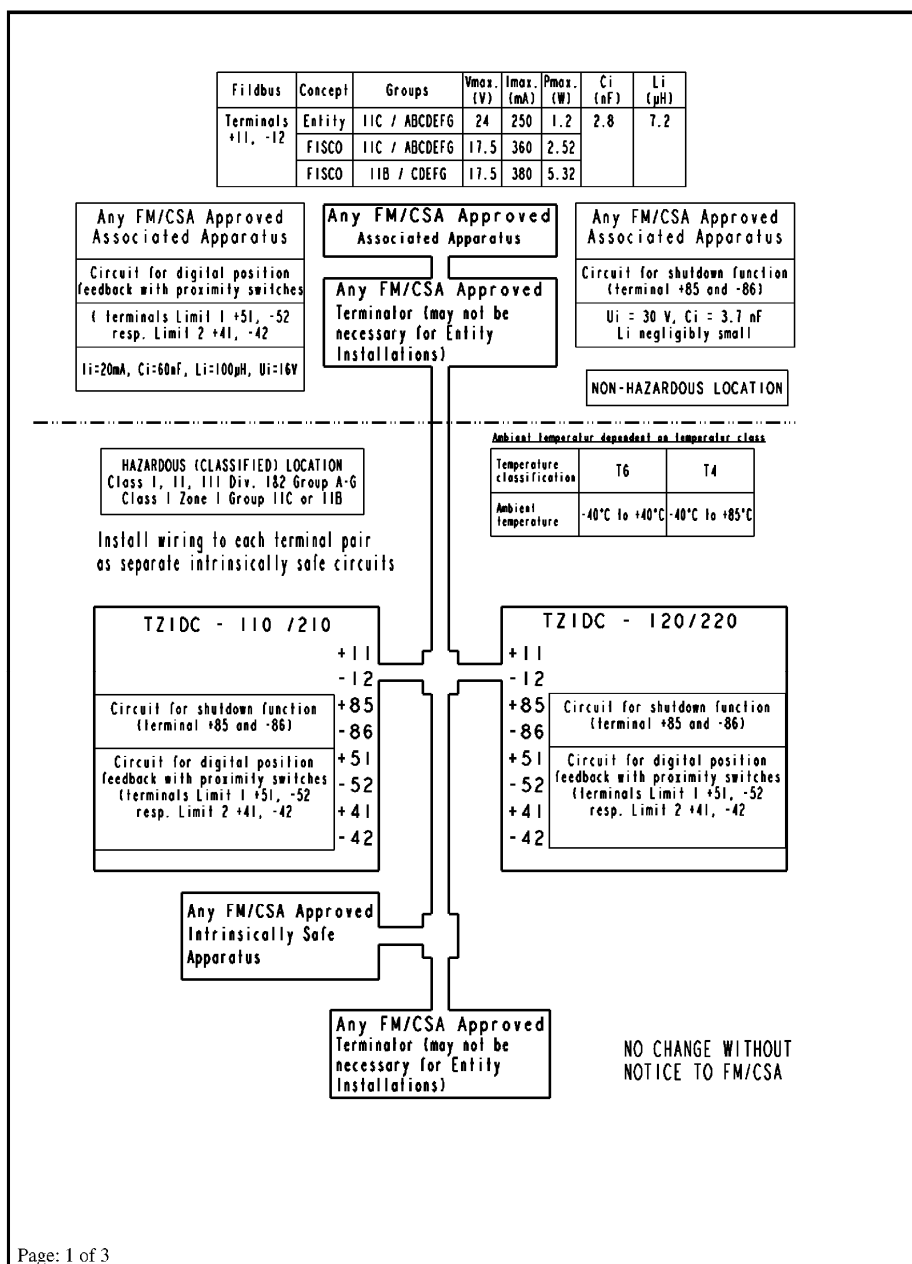

Page: 1 of 3

Rev.	Chang	Date	Name	2003	Date	Name	Title	Scale
-	-						FM/CSA-Control-Document	/
				Name	27.03.03	Thiem.		
				Appr.				
				Std.				
3	Rev.2	26.06.06	Thie.	ABB Automation Products			Drwg.-No. (Part-No.)	
2	Rev.1	22.05.06	Thie.				901265	
1	Rev.0	27.03.	Thie.					
Rev.	Chang	Date	Name				Supersedes Dwg. :	Part Class:

Page: 2 of 3				FM/CSA-CONTROL-DOCUMENT_901265				
FISCO rules								
<p>The FISCO Concept allows the interconnection of intrinsically safe apparatus to associated apparatus not specifically examined in such combination. The criterion for such interconnection is that the voltage (Vmax), the current (Imax) and the power (Pi) which intrinsically safe apparatus can receive and remain intrinsically safe, considering faults, must be equal or greater than the voltage (Uo, Voc, Vt), the current (Io, Isc, It,) and the power (Po) which can be provided by the associated apparatus (supply unit). In addition, the maximum unprotected residual capacitance (Ci) and inductance(Li) of each apparatus (other than the terminators) connected to the Fieldbus must be less than or equal to 5nF and 10 µH respectively.</p> <p>In each I.S. Fieldbus segment only one active source, normally the associated apparatus, is allowed to provide the necessary power for the Fieldbus system. The allowed voltage (Uo, Voc, Vt) of the associated apparatus used to supply the bus must be limited to the range of 14V d.c. to 24V d.c. All other equipment connected to the bus cable has to be passive, meaning that the apparatus is not allowed to provide energy to the system, except to a leakage current of 50 µA for each connected device. Separately powered equipment needs a galvanic Isolation to insure that the intrinsically safe Fieldbus circuit remains passive.</p> <p>The cable used to interconnect the devices needs to comply with the following parameters:</p> <p>Loop resistance R': 15...150 Ω/km Inductance per unit length L': 0.4...1mH/km Capacitance per unit length C':80...200 nF / km $C' = C' \text{ line/line} + 0.5C' \text{ line/screen}$, if both lines are floating or $C' = C' \text{ line/line} + C' \text{ Line/screen}$, if the screen is connected to one line Length of spur cable: max. 30m Length of trunk cable: max. 1km Length of splice: max. 1m</p> <p>Terminators At each end of the trunk cable an approved line terminator with the following parameters is suitable: $R = 90 \dots 100 \Omega$ $C = 0 \dots 2.2 \mu\text{F}$</p> <p>System evaluation The number of passive devices like transmitters, actuators, connected to a single bus segment is not limited due to I.S. Reasons. Furthermore, if the above rules are respected, the inductance and capacitance of the cable need not to be considered and will not impair the intrinsic safety of the installation.</p>								
-	-			2003	Date	Name	Title	Scale
				Name	27.03.03	Thiem.	FM/CSA-Control-Document	/
				Appr.				
				Std.				
3	Rev.2	26.06.06	Thie.	ABB Automation Products			Drwg.-No. (Part-No.)	
2	Rev.1	22.05.06	Thie.				901265	
1	Rev.0	27.03.	Thie.					
Rev.	Chang	Date	Name				Supersedes Dwg. :	Part Class:

Page: 3 of 3

FM/CSA-CONTROL-DOCUMENT_901265

Installation Notes For FISCO and Entity Concepts:

- The Intrinsic Safety Entity concept allows the interconnection of FM/CSA Approved Intrinsically safe devices with entity parameters not specifically examined in combination as a system when:
 U_o or V_{oc} or $V_t \leq V_{max}$, I_o or I_{sc} or $I_t \leq I_{max}$, $P_o \leq P_i$. C_a or $C_o \geq \sum C_i + \sum C_{cable}$.
 For inductance use either L_a or $L_o \geq \sum L_i + \sum L_{cable}$ or $L_c / R_c \leq (L_a / R_a \text{ or } L_o / R_o)$ and $L_i / R_i \leq (L_a / R_a \text{ or } L_o / R_o)$
- The Intrinsic Safety FISCO concept allows the interconnecting of FM/CSA Approved Intrinsically safe devices with FISCO parameters not specifically examine in combination as a system when: U_o or V_{oc} or $V_t \leq V_{max}$, I_o or I_{sc} or $I_t \leq I_{max}$, $P_o \leq P_i$.
- Control equipment connected to the Associated Apparatus must not use or generate more than 250 Vrms or Vdc.
- Installation should be in accordance with ANSI/ISA RP12.6 (except chapter 5 for FISCO Installations) "Installation of Intrinsically Safe System for Hazardous (Classified) Locations" and the National Electrical Code® (ANSI/NFPA 70) Sections 504 and 505.
- The configuration of associated Apparatus must be Factory Mutual Research /Canadian Standards Association Approved under the associated concept.
- Associated Apparatus manufacturer's installation drawing must be followed when installing this equipment.
- No revision to drawing without prior Factory Mutual Research Approval/Canadian Standards Association.
- Special conditions for safe use
 The operation of the local communication interface (LKS) and of the programming interface (X5) is only allowed outside of the Hazardous explosive area.

NONINCENDIVE, CLASS I, DIV. 2, GROUP A, B, C, D, AND FOR CLASS II AND III, DIV. 1&2, GROUP E, F, G
 HAZARDOUS LOCATION INSTALLATION.

- Install per National Electrical Code (NEC) using threaded metal conduit. Intrinsic safety barrier required. Max. Supply voltage 30 V. For T-code see table.
- A dust tight seal must be used at the conduit entry when the positioner is used in a Class II & III Location.
- WARNING: Explosion Hazard – do not disconnect equipment unless power has been switched off or the area is known to be Non-Hazardous.
 WARNING: Substitution of components may impair suitability for hazardous locations.

2003	Date	Name	Title	Scale
	27.03.03	Thiem.	FM/CSA-Control-Document	/
		Appr.		
		Std.		
			Drwg.-No. (Part-No.)	
Automation Products			901265	
3	Rev.2	26.06.06	Thie.	
2	Rev.1	22.05.06	Thie.	
1	Rev.0	27.03.	Thie.	
Rev.	Chang	Date	Name	Supersedes Dwg. : Part Class:

11 Parameter descriptions

11.1 TZIDC

11.1.1 Parameter overview



Abb. 27: Parameter overview

Parameter descriptions

11.1.2 Parameter description

Lev	Display	Function	Funktion	Parameter	Unit	Factory setting
P1._	STANDARD					
P1.0	ACTUATOR	Actuator type	Antriebsart	LINEAR, ROTARY	---	LINEAR
P1.1	AUTO_ADJ	Auto adjust	Selbstabgleich	Function	---	---
P1.2	ADJ_MODE	Auto adjust mode	Selbstabgleichsmodus	"FULL,STROKE,CTRL_PAR, ZERO_POS, LOCKED"		FULL
P1.3	TEST	Test	Test	Function	---	INACTIVE
P1.4	EXIT	Return	Zurück z. Arbeitsebene	Function	---	NV_SAVE
P2._	SETPOINT					
P2.0	MIN_RGE	Min setpoint range	Sollwertbereich Min.	4.0 ... 18.4	mA	4.0
P2.1	MAX_RGE	Max setpoint range	Sollwertbereich Max.	20.0 ... 5.6	mA	20.0
P2.2	CHARACT	Charact. curve	Kennlinie	LINEAR, 1:25, 1:50, 25:1, 50:1, USERD	---	LINEAR
P2.3	ACTION	Valve action	Wirkrichtung Ausgang	DIRECT, REVERSE	---	DIRECT
P2.4	SHUT_CLS	Shut-off value 0%	Dichtschliefbereich 0%	OFF, 0.1 ... 45.0	%	1.0
P2.5	SHUT_OPN	Shut off value 100%	Dichtschliefbereich 100%	55.0 ... 100.0, OFF	%	OFF
P2.6	RAMP UP	Set point ramp, up	Sollwertrampe n. oben	OFF, 0 ... 200	---	OFF
P2.7	RAMP DN	Set point ramp, down	Sollwertrampe n. unten	OFF, 0 ... 200	---	OFF
P2.8	EXIT	Return	Zurück z. Arbeitsebene	Function	---	NV_SAVE
P3._	ACTUATOR					
P3.0	MIN_RGE	Min. of stroke range	Arbeitsbereich Min.	0.0 ... 90.0	%	0.0
P3.1	MAX_RGE	Max. of stroke range	Arbeitsbereich Max.	100.0 ... 10.0	%	100
P3.2	ZERO_POS	Zero position	Nullpunktflage	CLOCKWISE, CTCLOCKWISE	---	CTCLOCKWISE
P3.3	EXIT	Return	Zurück z. Arbeitsebene	Function	---	NV_SAVE
P4._	MESSAGES					
P4.0	TIME_OUT	Control time out	Stellzeitüberwachung	OFF, ... 200	---	OFF
P4.1	POS_SW1	Position switch 1	Schaltpunkt SW1	0.0 ... 100.0	%	0.0
P4.2	POS_SW2	Position switch 2	Schaltpunkt SW2	0.0 ... 100.0	%	100.0
P4.3	SW1_ACTV	Switchpoint 1 enable	Aktive Richtung SW1	FALL_BEL, EXCEED	---	FALL_BEL
P4.4	SW2_ACTV	Switchpoint 2 enable	Aktive Richtung SW2	FALL_BEL, EXCEED	---	EXCEED
P4.5	EXIT	Return	Zurück z. Arbeitsebene	Function	---	NV_SAVE
P5._	ALARMS					
P5.0	LEAKAGE	Leakage detection	Leckage zum Antrieb	ACTIVE, INACTIVE	---	INACTIVE
P5.1	SP_RGE	Setpoint rng monitor	Außerh. d. Sollwertber.	ACTIVE, INACTIVE	---	INACTIVE
P5.2	SENS_RGE	Sens. range monitor	Nullpunktfehler	ACTIVE, INACTIVE	---	INACTIVE
P5.3	CTRLER	Controller monitor	Regler inaktiv	ACTIVE, INACTIVE	---	INACTIVE
P5.4	TIME-OUT	Control time-out	Stellzeitüberwachung	ACTIVE, INACTIVE	---	INACTIVE
P5.5	STRK_CTR	Stroke counter	Bewegungszähler	ACTIVE, INACTIVE	---	INACTIVE
P5.6	TRAVEL	Travel counter	Wegzähler	ACTIVE, INACTIVE	---	INACTIVE
P5.7	EXIT	Return	Zurück z. Arbeitsebene	Function	---	NV_SAVE
P6._	MAN_ADJ					
P6.0	MIN_VR	Min. valve range	Arbeitsbereich Min.	0.0 ... 100.0	%	0
P6.1	MAX_VR	Max. valve range	Arbeitsbereich Max.	0.0 ... 100.0	%	100
P6.2	ACTUATOR	Actuator type	Antriebsart	LINEAR, ROTARY	---	LINEAR
P6.3	SPRNG_Y2	Spring action (Y2)	Federwirkung (Y2)	CLOCKWISE, CTCLOCKWISE	---	CTCLOCKWISE
P6.4	DANG_DN	Dead angle close	Toter Winkel 0%	0.0 ... 45.0	%	0.0
P6.5	DANG_UP	Dead angle open	Toter Winkel 100%	55.0 ... 100.0	%	100.0
P6.6	EXIT	Return	Zurück z. Arbeitsebene	Function	---	NV_SAVE

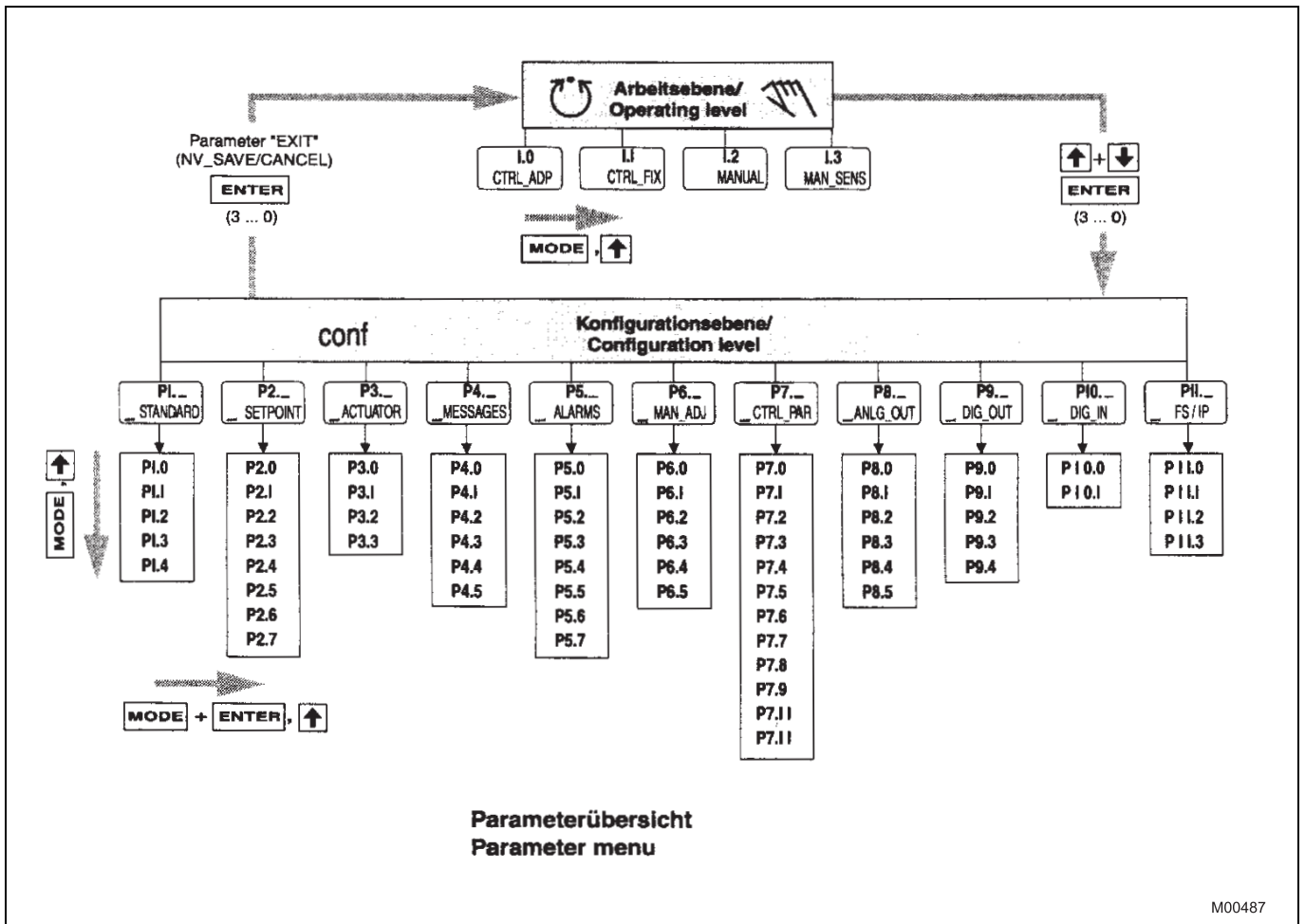
Lev	Display	Function	Funktion	Parameter	Unit	Factory setting
P7._	CTRL_PAR					
P7.0	KP UP	KP value, up	KP-Wert, nach oben	0.1 ... 120.0	---	5.0
P7.1	KP DN	KP value, down	KP-Wert, nach unten	0.1 ... 120.0	---	5.0
P7.2	TV UP	TV value, up	TV-Wert, nach oben	10 ... 450	---	200
P7.3	TV DN	TV value, down	TV-Wert, nach unten	10 ... 450	---	200
P7.4	Y-OFS UP	Y offset, up	Y-Offset, nach oben	0.0 ... 100.0	%	48.0
P7.5	Y-OFS DN	Y offset, down	Y-Offset, nach unten	0.0 ... 100.0	%	48.0
P7.6	TOL_BAND	Toleranzband (zone)	Toleranzband (Zone)	0.3 ... 10.0	%	1.5
P7.7	DEADBAND	Deadband	Totband	0.10 ... 10.00	%	0.10
P7.8	DB_APPR	Deadband Approach	Totbandannäherung	SLOW, MEDIUM, FAST		
P7.9	TEST	Test	Test	Function	---	INACTIVE
P7.10	EXIT	Return	Zurück z. Arbeitsebene	Function	---	NV_SAVE
P8._	ANLG_OUT					
P8.0	MIN_RGE	Min. range	Strombereich Min.	4.0 ... 18.4	mA	4.0
P8.1	MAX_RGE	Max. range	Strombereich Max.	20.0 ... 5.7	mA	20.0
P8.2	ACTION	Action	Wirkrichtung d. Kennl.	DIRECT, REVERSE	---	DIRECT
P8.3	ALARM	Alarm current	Alarmmeldung	HIGH_CUR, LOW_CUR	---	HIGH_CUR
P8.4	RB_CHAR	Readback character.	Zurückgerechn. Charakt.	DIRECT, RECALC		DIRECT
P8.5	TEST	Test	Test	Function	---	NONE
P8.6	EXIT	Return	Zurück z. Arbeitsebene	Function	---	---
P9._	DIG_OUT					
P9.0	ALRM_LOG	Alarm logic	Logik Alarmausgang	ACTIVE_HI, ACTIVE_LO	---	ACTIVE_HI
P9.1	SW1_LOG	Switchpoint 1 logic	Logik SW1	ACTIVE_HI, ACTIVE_LO	---	ACTIVE_HI
P9.2	SW2_LOG	Switchpoint 2 logic	Logik SW2	ACTIVE_HI, ACTIVE_LO	---	ACTIVE_HI
P9.3	TEST	Test	Test	Function	---	NONE
P9.4	EXIT	Return	Zurück z. Arbeitsebene	Function	---	NV_SAVE
P10._	DIG_IN					
P10.0	FUNCTION	Function select	Funktionsauswahl	NONE, POS_0 %, POS_100 %, POS_HOLD	---	NONE
P10.1	EXIT	Return	Zurück z. Arbeitsebene	Function	---	---
P11._	FS/IP					
P11.0	FAIL_POS	Save position	Sicherheitsstellung	ACTIVE, INACTIVE	---	INACTIVE
P11.1	FACT_SET	Factory setting	Werkseinstellung	Function	---	START
P11.2	IP-TYP	I/P module type	Typ des I/P-Moduls	NO_F_POS,F_SAFE_1,F_SAFE_2, F_FREEZE1,F_FREEZE2	---	[CUSTOM]
P11.3	EXIT	Return	Zurück z. Arbeitsebene	Function	---	NV_SAVE

Parameter descriptions

11.2 TZIDC-110 / TZIDC-120

11.2.1 Parameter overview

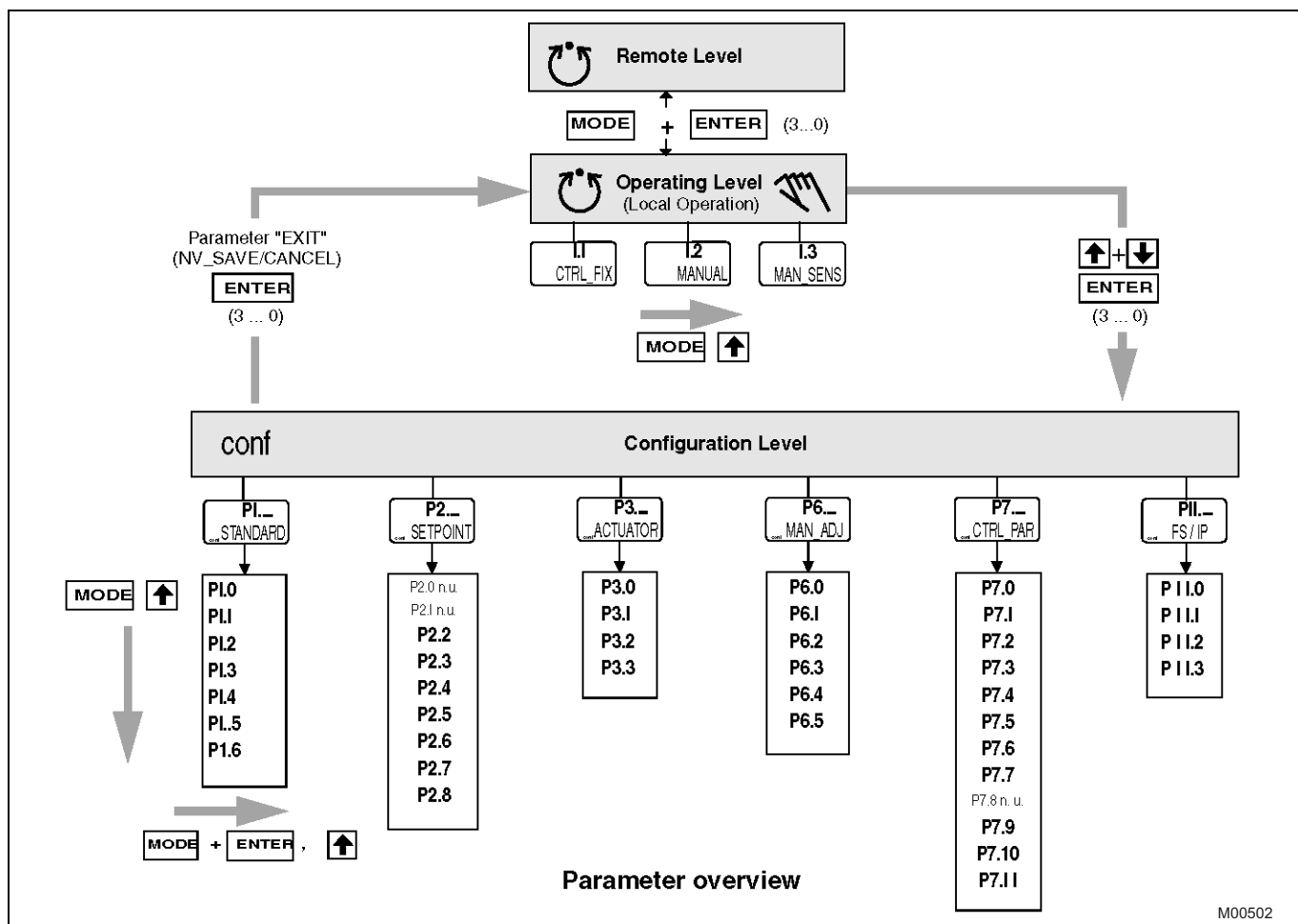

Fig. 28: Parameter overview





11.2.2 Parameter description

Parameter	Display	Function	Parameter	Unit	Factory setting	Customer setting
P1._	STANDARD					
P1.0	ACTUATOR	Actuator type	LINEAR, ROTARY	---	LINEAR	
P1.1	AUTO_ADJ	Auto adjust	Function	---	---	---
P1.2	TOL_BAND	Tolerance band	0,30 ... 10,00	%	0,30	
P1.3	DEADBAND	Dead band	0,10 ... 10,00	%	0,10	
P1.4	TEST	Test	Function	---	---	---
P1.5 ¹⁾	ADRESS	Busadresse	1 ... 126	---	126	---
P1.6	EXIT	Return to operat. level	Function	---	---	---
P2._	SETPOINT					
P2.0				---	---	---
P2.1				---	---	---
P2.2	CHARACT	Characteristic curve	LINEAR, EP 1:25, 1:50, 25:1, 50:1, USERDEF	---	LINEAR	
P2.3	ACTION	Action of the output	DIRECT, REVERSE	---	DIRECT	
P2.4	SHUT-CLS	Shut-off range 0%	OFF, 0,1 ... 45	%	off	
P2.5	RAMP^	Set point ramp, up	OFF, 0,1 ... 999,9	sec	off	
P2.6	RAMP~	Set point ramp, down	OFF, 0,1 ... 999,9	sec	off	
P2.7	SHUT-OPN	Shut-off range 100%	OFF, 80,0 ... 100	%	off	
P2.8	EXIT	Return to operat. level	Function	---	---	---
P3._	ACTUATOR					
P3.0	MIN_RGE	Min. of operating range	0,0 ... 100,0	%	0,0	
P3.1	MAX_RGE	Max. of operating range	0,0 ... 100,0	%	100,0	
P3.2	ZERO_POS	Zero position	CLOCKWISE, CTCLOCKWISE	---	CTCLOCKWISE	
P3.3	EXIT	Return to operat. level	Function	---	---	---
P4._, P.5_				---	---	---
P6._	MAN_ADJ					
P6.0	MIN_VR	Min. operating range	0,0 ... 100,0	%	0,0	
P6.1	MAX_VR	Max. operating range	0,0 ... 100,0	%	100,0	
P6.2	ACTUATOR	Actuator type	LINEAR, ROTARY	---	LINEAR	
P6.3	SPRNG_Y2	Spring action (Y2)	CLOCKWISE, CTCLOCKWISE	---	CTCLOCKWISE	
P6.4	ADJ_MODE	Auto adjust mode	FULL, STROKE, CTRL_PAR, ZERO_POS, LOCKED	---	FULL	
P6.5	EXIT	Return to operat. level	Function	---	---	---
P7._	CTRL_PAR					
P7.0	KP^	KP value, up	1,0 ... 100,0	---	1,0	
P7.1	KPv	KP value, down	1,0 ... 100,0	---	1,0	
P7.2	TV ^	TV value, up	0 ... 1000	msec	100	
P7.3	TVv	TV value, down	0 ... 1000	msec	100	
P7.4	GOPULSE^	Go pulse, up	0 ... 200	msec	0	
P7.5	GOPULSEv	Go pulse, down	0 ... 200	msec	0	
P7.6	Y-OFFSET^	Y offset, up	Y-Min ... 100,0	%	40,0	
P7.7	Y-OFFSETv	Y offset, down	Y-Min ... 100,0	%	40,0	
P7.8				---	---	---
P7.9	TOL_BAND	Tolerance band	0,30 ... 10,00	%	0,8	
P7.10	TEST	Test	Function	---	---	---
P7.11	EXIT	Return to operat. level	Function	---	---	---
P8._, P9._, P.10_				---	---	---
P11._	FS/IP					
P11.0	FAIL_POS	Save position selection	ACTIVE, INACTIV	---	INACTIV	
P11.1	FACT_SET	Factory setting	Function	---	---	---
P11.2	IP_TYP	I/P module type	NO_F_POS, F_SAFE_1, F_SAFE_2, F_FREEZE1, F_FREEZE2	---	NO_F_POS	
P11.3	EXIT	Return to operat. level	Function	---	---	---

1) only TZIDC-110

12 Appendix

12.1 Approvals and certifications

CE mark		<p>The version of the meter in your possession meets the requirements of the following European directives:</p> <ul style="list-style-type: none"> - EMC directive 2014/30/EU - ATEX directive 2014/34/EU
Explosion Protection	   	<p>Identification for intended use in potentially explosive atmospheres according to:</p> <ul style="list-style-type: none"> - ATEX directive (marking in addition to CE marking) - IEC standards - FM Approvals (US) - CSA International (Canada)



IMPORTANT (NOTE)

All documentation, declarations of conformity and certificates are available in ABB's download area.

www.abb.com/positioners

Statement on the contamination of devices and components

Repair and / or maintenance work will only be performed on devices and components if a statement form has been completed and submitted.

Otherwise, the device / component returned may be rejected. This statement form may only be completed and signed by authorized specialist personnel employed by the operator.

Customer details:

Company: _____

Address: _____

Contact person: _____

Telephone: _____

Fax: _____

E-mail: _____

Device details:

Type: _____

Serial no.: _____

Reason for the return/description of the defect: _____

Was this device used in conjunction with substances which pose a threat or risk to health?

Yes No

If yes, which type of contamination (please place an X next to the applicable items)?

Biological Corrosive / irritating Combustible (highly / extremely combustible)

Toxic Explosive Other toxic substances

Radioactive

Which substances have come into contact with the device?

- 1. _____
- 2. _____
- 3. _____

We hereby state that the devices / components shipped have been cleaned and are free from any dangerous or poisonous substances.

Town/city, date

Signature and company stamp

ABB has Sales & Customer Support expertise in over 100 countries worldwide.

www.abb.com/positioners

The Company's policy is one of continuous product improvement and the right is reserved to modify the information contained herein without notice.

Printed in the Fed. Rep. of Germany (04.2016)

© ABB 2016

3KXE341007R4201



ABB Limited
Process Automation
Howard Road, St. Neots
Cambridgeshire, PE19 8EU
UK
Tel: +44 (0)870 600 6122
Fax: +44 (0)1480 213 339
Mail: enquiries.mp.uk@gb.abb.com

ABB Inc.
Process Automation
125 E. County Line Road
Warminster, PA 18974
USA
Tel: +1 215 674 6000
Fax: +1 215 674 7183

ABB Automation Products GmbH
Process Automation
Schillerstr. 72
32425 Minden
Germany
Tel: +49 571 830-0
Fax: +49 571 830-1806