



FIREYE® 25SU3-2150 RACK-MOUNTED FLAME-SAFEGUARD AMPLIFIER



DESCRIPTION

The **25SU3-2150** is used to detect the presence or absence of a flame in a single or multi-burner environment. It also maximizes burner discrimination with its ability to accurately differentiate the Flame ON and Flame OFF rates produced by the scanners.

The **25SU3-2150** has the capacity to receive pulse inputs from two flame scanners, “A” and “B”, either separately or in combination. In addition, it has two logic programs available, called “Scanner Option 1” and “Scanner Option 2.” Within these two scanner options, the user may select different operating parameters, and select the scanner or scanners that will provide the pulse input for that option. Switching between “Scanner Option 1” and “Scanner Option 2” is accomplished by an external dry contact input to the amplifier. The dynamic range is 1900 pulses per second, which is consistent with the output range provided by Fireeye scanners. The pulse rate output of each scanner is directly viewed by the user.

The design platform of the 25SU3 is based on the global 3U EUROCARD format with the unit operating on either 24 VAC or 24 VDC. Fireeye offers full racks and half-racks for mounting, as well as several different power supplies for various scanner/amplifier combinations. See Ordering Information.

The model **25SU3-2150** control includes revised circuitry and is enclosed in a metal case specifically designed to enhance electrical noise rejection.

FEATURES

- Keypad Entry system
- Password protection to avoid unauthorized alteration of the user-set (programmed) parameters.
- Eight character alpha-numeric display.
- Front panel LED Status Indicator.
- Adjustable Independent Flame Relay Pull-In and Drop-Out Thresholds.
- Adjustable Flame Failure Response Time (FFRT) (1 to 6 secs.).
- Adjustable Independent Flame Relay Delay On Time (0 to 10 secs.).
- Capable of analyzing signals from two scanners.
- One Form C SPDT Alarm relay.
- One fused DPDT Form C Flame relay.
- One 4 - 20mA analog output (used to measure flame signal—scalable).



TABLE OF CONTENTS

DESCRIPTION	PAGE
COMPATIBLE FIREYE FLAME SCANNERS	3
ORDERING INFORMATION	4
HARDWARE COMPONENTS	5
25SU3-2150 SPECIFICATIONS	5-7
MOUNTING RACK SPECIFICATIONS	8
INSTALLATION OF AMPLIFIERS AND POWER SUPPLIES	9-11
FRONT PANEL LAYOUT AND DESCRIPTION	11-12
OPERATION, GENERAL	12
STATUS AND SETPOINTS MENU	13-19
PASSWORD PROTECTION	19-20
PROGRAMMING SETPOINTS, EXAMPLE	21
ELECTRICAL WIRING DIAGRAM - GENERAL	22
RACK CONNECTOR KIT	22-23
25SU3-2150 ELECTRICAL WIRING DIAGRAMS	24-26
SCANNER CABLE CONNECTION	27-28



COMPATIBLE FIREYE FLAME SCANNERS

TYPE/MODEL	FREQ. Hz	WAVE- LENGTH (nanometers)	MOUNT THREADS	AMBIENT TEMP. MAX., MIN.	SAFETY APPROVALS	BULLETIN	NOTES
45UV5-1000EC	60	180 - 250	1" NPT	200°F (93°C) - 40°F (-40°C)	FM, CSA	CU-22, CU-55	1, 2 and 3
45UV5-1010EC	60	180 - 250	1" BSP	200°F (93°C) - 40°F (-40°C)	FM, CSA	CU-22, CU-55	1, 2 and 3
45UV5-1101EC	50	180 - 250	1" BSP	200°F (93°C) - 40°F (-40°C)	FM, CE, CSA	CU-22, CU-55	1, 2, and 3
45RM1-1001EC	50/60	450 - 1,000	1" NPT	150°F (65°C) - 40°F (-40°C)	FM, CSA	CU-26, CU-55	1, 2 and 3
45RM1-1003EC	50/60	450 - 1,000	1" BSP	150°F (65°C) - 40°F (-40°C)	FM, CE, CSA	CU-26, CU-55	1, 2 and 3
61-4892-2EC	50/60	450 - 1,000	Fiber Optic 45RM1	150°F (65°C) - 40°F (-40°C)	FM, CSA	CU-26, CU-21, CU-55	1 2 and 3
45RM2-1000EC	50/60	700 - 2,500	1" NPT	150°F (65°C) - 40°F (-40°C)	FM, CSA	CU-26, CU-55	1, 2 and 3
45RM2-1001EC	50/60	700 - 2,500	1" BSP	150°F (65°C) - 40°F (-40°C)	FM, CE, CSA	CU-26, CU-55	1, 2 and 3
61-5234EC	50/60	700 - 2,500	Fiber Optic 45RM2	150°F (65°C) - 40°F (-40°C)	FM, CSA	CU-26, CU-21, CU-55	1, 2 and 3
45RM4-1000EC	24VDC	700 - 2,500	1" NPT	150°F (65°C) - 40°F (-40°C)	FM, CSA	CU-31, CU-55	2 and 3
45RM4-1001EC	24VDC	700 - 2,500	1" BSP	150°F (65°C) - 40°F (-40°C)	FM, CE, CSA	CU-31, CU-55	2 and 3
61-6521EC	24VDC	700 - 2,500	Fiber Optic 45RM4	150°F (65°C) - 40°F (-40°C)	FM, CSA	CU-26, CU-21, CU-55	2 and 3

Note 1: Requires 19UVPS-2120 or -2220 power supply.

Note 2: Scanners with "EC" suffix are supplied with Mil Spec. EMI hardened electrical quick disconnect. These are for use with Fireye scanner cable 59-491.

Note 3: "EC" style scanners are now obsolete. 25SU3-2150 amplifier can be used with "non-EC" style scanners (e.g. 45UV5-1000, 45RM4-1000).



ORDERING INFORMATION

Part Number	Description
25SU3-2150	Rack mount flame safeguard amplifier
Mounting Racks:	
60-2471-1EC	Half mounting rack. Includes one (1) each 60-2478 connector and EMI filter board and bus bar and ferrite core.
60-2471-3EC	Full mounting rack. Includes one (1) each 60-2478 connector and EMI filter board and bus bar.
Filler Plates	
60-2490-2	Front filler plate for mounting racks. Approx 0.4" (2 HP)
60-2490-4	Front filler plate for mounting racks. Approx 0.8" (4 HP)
60-2490-6	Front filler plate for mounting racks. Approx 1.2" (6 HP)
60-2490-8	Front filler plate for mounting racks. Approx 1.6" (8 HP)
60-2490-10	Front filler plate for mounting racks. Approx 2.0" (10 HP)
Power Supplies	
60-2470-1	Power supply. 110 VAC Input/24 VDC, 2.5 Amps Output for 25SU3 amplifiers and low voltage scanners. Includes 60-2482 connector.
60-2470-2	Power supply. 220-240 VAC Input/24 VDC, 2.5 Amps Output for 25SU3 amplifiers and low voltage scanners. Includes 60-2482 connector.
19UVPS-2120	Power supply. 110 VAC Input for up to six (6) AC line voltage scanners only. Requires 60-2478 or 60-2480 Connector. Refer to Bulletin CU-38.
19UVPS-2220	Power supply. 220 VAC Input for up to six (6) AC line voltage scanners only. Requires 60-2478 or 60-2480 Connector. Refer to Bulletin CU-38.
Connectors	
60-2478	Screw terminal straight style (12 AWG) connector for 25SU3 amplifier or 19UVPS power supply.
60-2480	Screw terminal Y style (12 AWG) connector for 19UVPS power supply.
61-6898-1	Connector Kit, includes 60-2478 connector, EMI filter board and bus bar, and ferrite core.
61-6898-2	EMI filter board and bus bar.
60-2482	1/4" Tab terminal connector for 60-2470.
Replacement Fuse	
23-182	Replacement power fuse for (1.5 Amp. fast-acting type), (LittleFuse P/N 273 01.5).

Note: Refer to Bulletin CU-55 for a listing of type "EC" scanners, cables and accessories.

HARDWARE COMPONENTS

The following figures show the components making up the 25SU3-2150 system.



AMPLIFIER WITH KEYPAD/DISPLAY
PART NUMBER 25SU3-2150



POWER SUPPLY
PART NUMBER 60-2470-1 (110 VAC)
60-2470-2 (220 VAC)

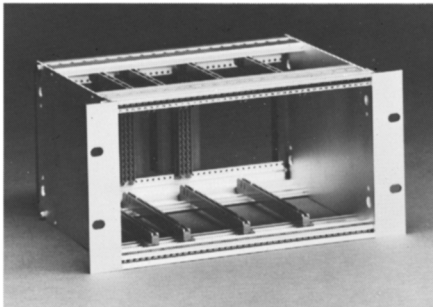

HALF RACK PART NUMBER 60-2471-1EC

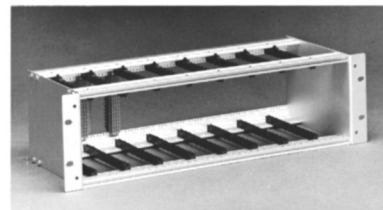

FULL RACK PART NUMBER 60-2471-3EC

25SU3-2150 SPECIFICATIONS

DIMENSIONS (Figure 1)

Height:	5.06 inches (128.5 mm)
Depth:	8.0 inches (203.2 mm)
Width (Front Panel):	1.98 inches (50.3 mm) 10HP
Thickness (Front Panel):	0.093 inches (2.4 mm)

Self-Check Timings:	Open: 3.5 sec.
	Closed: 0.5 sec.



25SU3-2150 SPECIFICATIONS

FIGURE 1. 25SU3 -2150 DIMENSIONS

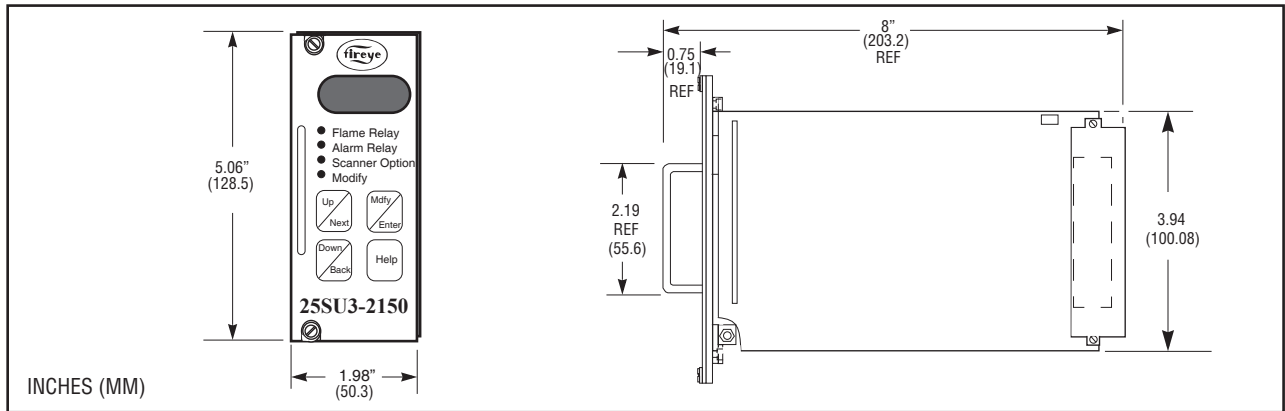

A standard full width 19" rack has a usable inside width of 16.8" (426.80mm). This allows for up to 8 amplifiers per rack.

SIGNAL INPUTS — Two flame scanner inputs.

ANALOG OUTPUT — 4-20mA output. Current *sourcing*, max. connected load = 1000 ohms.

OUTPUTS —

Contacts available:

- One flame relay, DPDT contacts:
- One set fused contacts (RF1) 1.5A.
- One alarm relay (SPDT)

Contact Ratings: Flame Relay and Alarm Relay

- Minimum:** 40mA resistive @ 24 VDC
- 40mA resistive @ 230 VAC
- Maximum:** 1A resistive at 24 VDC
- 1A resistive at 230 VAC

Contact Material: Silver cadmium oxide.

INPUT VOLTAGES — *24VAC (+10%, -15%) 50/60 Hz or 24 VDC (+/-10%)

POWER CONSUMPTION — Control with One Scanner: 5 VA
Control with Two Scanners: 7.5 VA

TEMPERATURE RANGE — Operating: - 4°F to +140° F
(- 20° C to +60° C)
Storage: - 4° F to +176° F
(- 20° C to +80° C)

HUMIDITY — 0% TO 85% R.H. non-condensing.

FLAME FAILURE RESPONSE TIME—1 to 6 secs (user-selectable).

SHIPPING WEIGHT — 1 lb. (454 grams)

MOUNTING — Rack Mount

KEYPAD/DISPLAY— Four (4) positive action membrane keys with embossed tactile feedback. Eight (8) Character Alpha-Numeric LED Display.

SAFETY APPROVALS — FM, CE

**If 24 VAC is supplied, do not connect to 120VAC neutral. 24VAC "floating" or "grounded" is acceptable.*

25SU3-2150 SPECIFICATIONS

FRONT PANEL STATUS LEDs

Four status LEDs

1. **Flame Relay** - Indicates (ON/OFF) Status of Flame Relay
2. **Alarm Relay** - Indicates (ON/OFF) Status of Alarm Relay (see page 14).
3. **Scanner Option** - Allows user to combine the signals from the connected scanner or scanners in a variety of logical configurations.
Steady State — Scanner Option 1 (SCN OPT1).
Blinking State — Scanner Option 2 (SCN OPT2).
4. **Modify** — Indicates that the Modify Mode is invoked and the user can make changes to parameters in the Setpoint group.

Note: See page 12 for additional information regarding the LEDs.

ELECTRONICS

The control is a microprocessor based system. The integrity of the micro-controller is checked by a “watchdog relay.” This relay state is periodically updated by the micro-controller and is dependent on the proper execution of the code programmed within the operating software. The scanners operate in the system in a self-checking mode.

Periodically, a self-check pulse is sent to each scanner to verify proper operation

CONNECTORS

P/N 61-6898-1** Rack Connector Kit:

The kit includes one P/N 60-2478 Screw Terminal Straight Connector, and one P/N 61-6898-2 EMI Filter Board / bus bar assembly and ferrite cores. Each Full Rack (P/N 60-2471-3EC), and each Half Rack (P/N 60-2471-1EC), come complete with one P/N 61-6898-1 kit. (Order additional kits for each additional 25SU3-2150 in the rack).

P/N 61-6898-2** EMI Filter Board / bus bar assembly:

Included in 61-6898-1** kit.

P/N 60-2478 Screw Terminal Straight Connector (12 AWG max.):

Included in 61-6898-1** kit.

REPLACEABLE FUSE

The 25SU3-2150 has one replaceable 1.5 amp fuse, (P/N 23-182), accessible at the bottom edge of the control using long-nose pliers. Fuse “F1” is for the amplifier power and fuse “F2” is for flame relay contacts RF-1 (see below)..

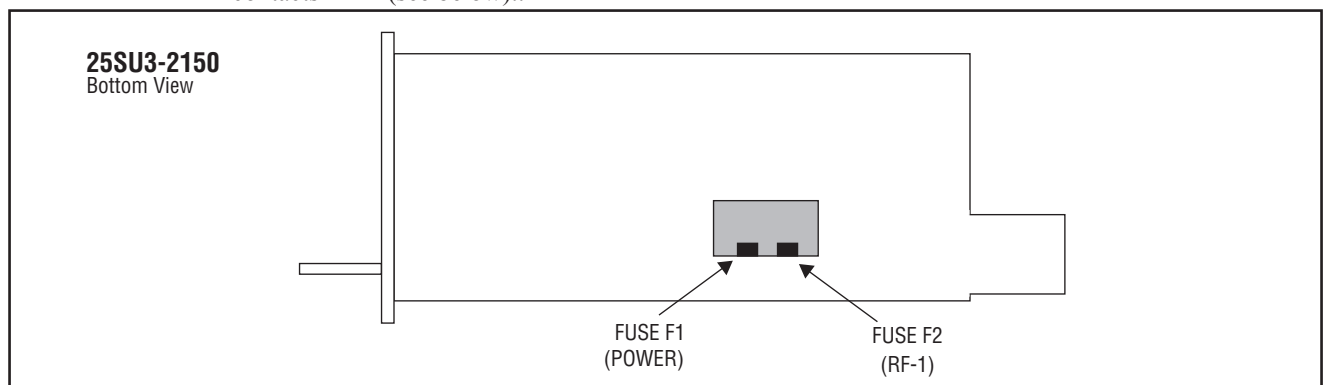

Note: Fuse F2 is not replaceable. If fuse F2 needs replacing, the amplifier **MUST** be sent back to manufacturer for replacement.

Note: **NOW OBSOLETE

MOUNTING RACK SPECIFICATIONS

There are two mounting racks for the installation of the 25SU3-2150 amplifiers and power supplies.

FIGURE 2. DIMENSIONS — SHOWN IN MM (INCHES)

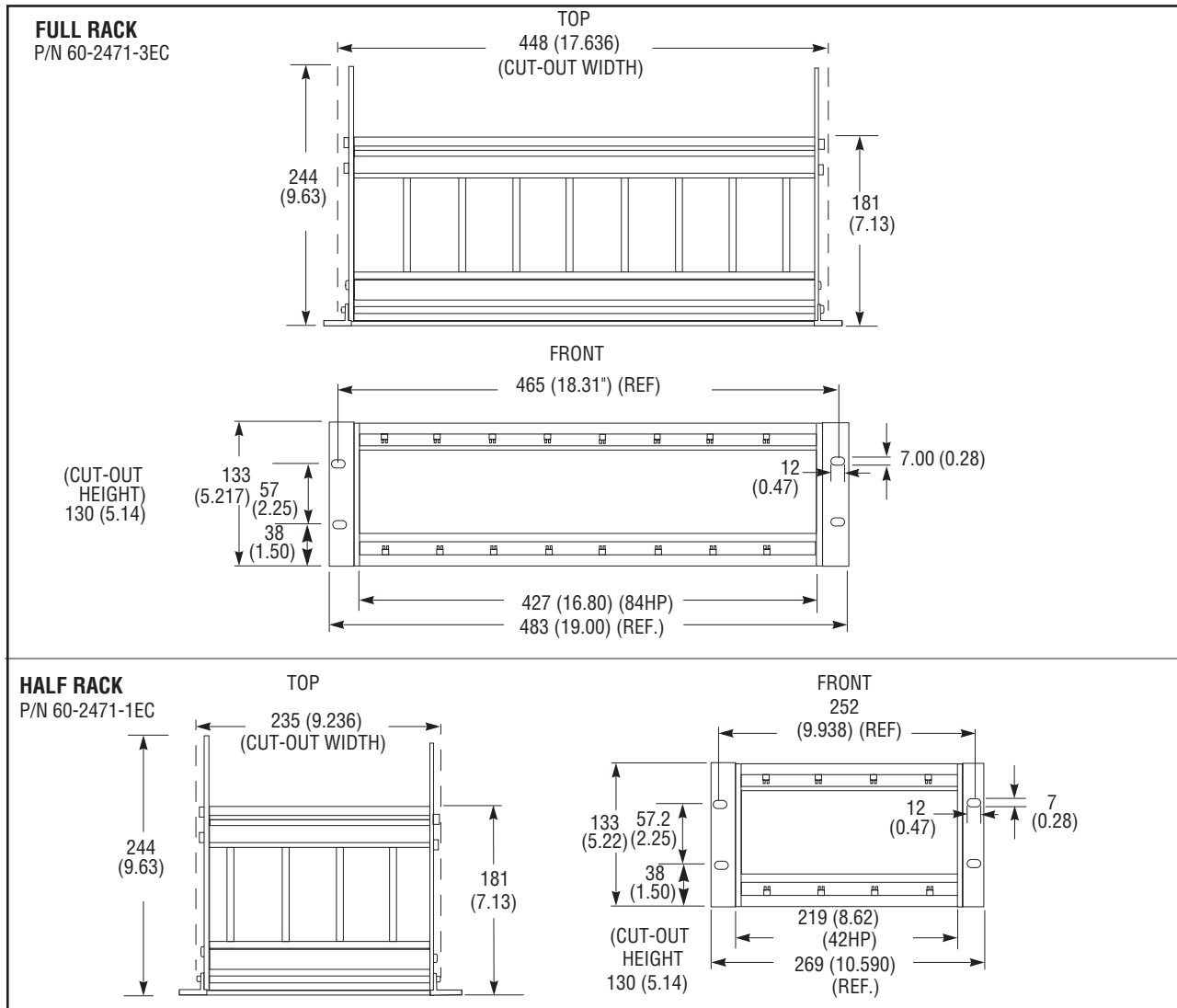

Half Racks (60-2471-1EC**)

The half rack has an aperture opening of 42 HP (Horizontal Pitch) or 8.4 inches (213.36 mm). 1 HP is approximately 0.2 inch. The 25SU3-2150 amplifier has a width of 10 HP (approx. 2"). The 60-2470 and 19UVPS power supplies have a width of 8 HP (approx. 1.6"). A half rack can accommodate up to 4 amplifiers or 3 amplifiers and 1 power supply.

Full Racks (60-2471-3EC**)

The full rack has an aperture opening of 84 HP (Horizontal Pitch) or 16.8 inches (426.72 mm). 1 HP is approximately 0.2 inch. The 25SU3-2150 amplifier has a width of 10 HP (approx. 2"). The 60-2470 and 19UVPS power supplies have a width of 8 HP (approx. 1.6"). A full rack can accommodate up to 8 amplifiers or 7 amplifiers and 1 power supply.

Note: If desired, filler plates are available to close any openings. Refer to the section on "Filler Plates."

*Note: **NOW OBSOLETE*

INSTALLATION OF AMPLIFIERS AND POWER SUPPLIES

The **Half Rack** (60-2471-1EC**) is shipped with 4 factory mounted rack guides with their centerlines (center groove of the rack guide) in positions 3, 13, 23, and 33 with their extensions facing right (as viewed from the top and front). See Figure 5. The half rack also includes one 61-6898-1 Rack Connector Kit screwed into position 34.

The **Full Rack** (60-2471-3EC**) is shipped with 8 factory mounted rack guides with their centerlines (center groove of the guide rack) in positions 5, 15, 25, 35, 45, 55, 65, and 75 with their extensions facing right (as viewed from the top and front). The full rack also includes one 61-6898-1** Rack Connector Kit screwed into position 76. Each position corresponds to approx 0.2 inches, or 1 HP (Horizontal Pitch). Each rack guide is factory shipped 10HP apart.

Note: The position of the rack guides is referenced to the centerline of the rack guide.

FIGURE 3. FACTORY DEFAULT GUIDES FOR HALF RACK

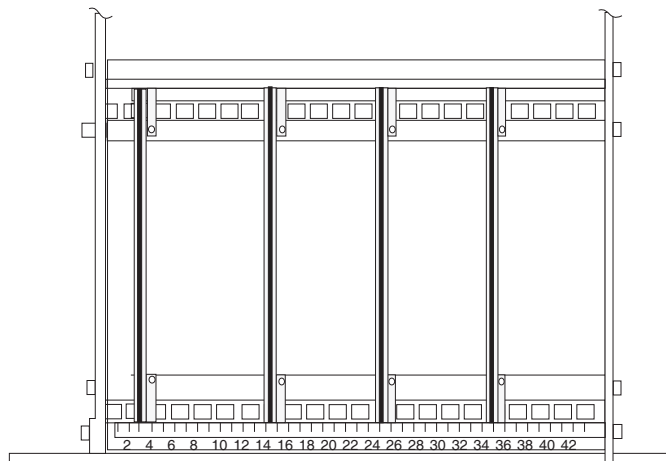

TO INSTALL THE 25SU3-2150:

First Amplifier: Each Full or Half Rack comes equipped with one Rack Connector Kit, P/N 61-6898-1**, which includes one 60-2478 Screw Terminal Connector installed into position 34 (Half Rack) or position 76 (Full Rack), and the 61-6898-2** EMI Filter Board / bus bar assembly installed immediately to its right.

Additional Amplifiers: The 25SU3-2150 is 10HP wide, so the rack guides do not have to be moved from the factory positions. The 60-2478 Screw Terminal Connector is installed one position away from the centerlines of the rack guides (to the right). Screw the connectors (60-2478) as required into positions 4, 14 and 24 (Half-Rack) and positions 6, 16, 26, 36, 46, 56 and 66 (Full Rack). The 61-6898-2** EMI Filter Board / bus bar assembly is then installed immediately to the right of the connector, with the contact fingers facing the connector.

TO INSTALL THE 19UVPS-2120, -2220 POWER SUPPLY

The 19UVPS power supply is only 8HP wide, and the rack guides are factory installed 10HP apart. There are two options for installing the power supply.

1. Use the existing rack guides. The connector for the 19UVPS power supply (60-2478 or 60-2480) is installed 1 position away from the centerline of the appropriate rack guide (e.g. screw the connector into position 14 if the power supply is mounted in the rack guide in position 13). If desired, a 2 HP filler plate (60-2490-2) will be required to close the opening between the 19UVPS power supply and 25SU3-2150 amplifier.
2. Assuming the amplifiers are installed in the far right positions, move the rack guide that is closest to the amplifiers 2 positions to the right as viewed from the front of the rack (e.g. from rack guide)

Note: **NOW OBSOLETE

3. position 13 to position 15 on the half rack). Install the connector (60-2478 or 60-2480) one position away from the centerline of the rack guide (e.g. rack guide moved to position 15, screw connector into position 16).

For example: A full rack (60-2471-3EC**) has five (5) amplifiers mounted in the factory installed rack guide positions 35, 45, 55, 65, and 75. Connectors are screwed into positions 36, 46, 56, 66, and 76. To install the 19UVPS power supply, move the rack guide from position 25 to position 27, and install the connector into position 28.

TO INSTALL 60-2470-1, -2 POWER SUPPLY

The 60-2470-1, -2 power supply is only 8HP wide and the rack guides are factory installed 10HP apart. **In addition, the 60-2470-1, -2 is a right hand mount** (the right side of the 60-2470-1,-2 power supply slides into the rack guides). The other power supplies and the 25SU3 amplifiers are left hand mount. Because the rack guides are factory installed 10HP apart for left hand mounts, the rack guides used for the 60-2470-1, -2 power supply **must be moved** so their extensions **face left** (as viewed from the front and top). See Figure 4.

Assuming the amplifiers and 19UVPS power supply (if used) are installed in the far right positions:

1. Remove an unused rack guide.
2. Reverse the position of the rack guide so the extensions are facing left (as viewed from the front or top).
3. Place the rack guide (with its extensions facing left) in the position immediately to the left of the rack guide for the amplifiers (or 19UVPS power supply). For example, the rack guide for the amplifier is installed in position 35 of the full rack, install the rack guide for the 60-2470-1, -2 power supply so its centerline is in position 34.
4. Install the connector (60-2482) 5 positions to the left of the rack guide (e.g. the centerline of the rack guide is in position 34, install the connector in position 29).

FIGURE 4. RACK GUIDE POSITIONS FOR 3 AMPLIFIERS AND 60-2470 POWER SUPPLY

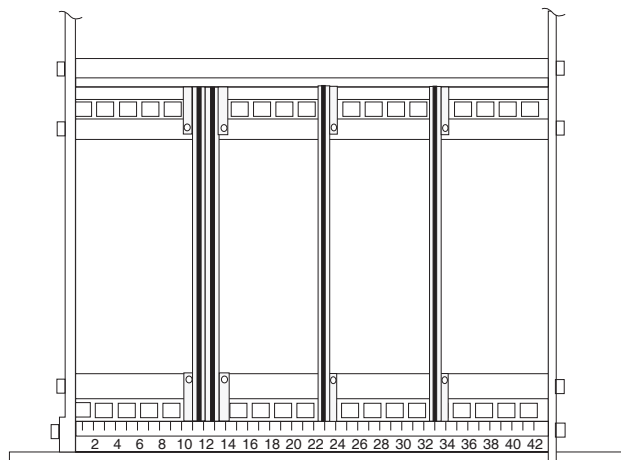

*Note: **NOW OBSOLETE*

FILLER PLATES

Filler plates are provided to cover any openings in the racks after the installation of the amplifiers and power supplies. Filler plates are offered in 2, 4, 6, 8, and 10 HP widths. 1 HP is approximately 0.2 inch. To determine the number and types of filler plates required, subtract the HP widths of each installed amplifier and power supply from the aperture opening of the mounting rack.

Mounting Racks		Amplifier and Power Supplies		Filler Plates	
Part #	Width	Part #	Width	Part #	Width
60-2471-3EC**	84 HP	25SU3-2150	10 HP	60-2490-2	2 HP
60-2471-1EC**	42 HP	60-2470	8 HP	60-2490-4	4 HP
		19UVPS	8 HP	60-2490-6	6 HP
				60-2490-8	8 HP
				60-2490-10	10 HP

FRONT PANEL OF 25SU3-2150

FIGURE 5. 25SU3-2150 FRONT PANEL

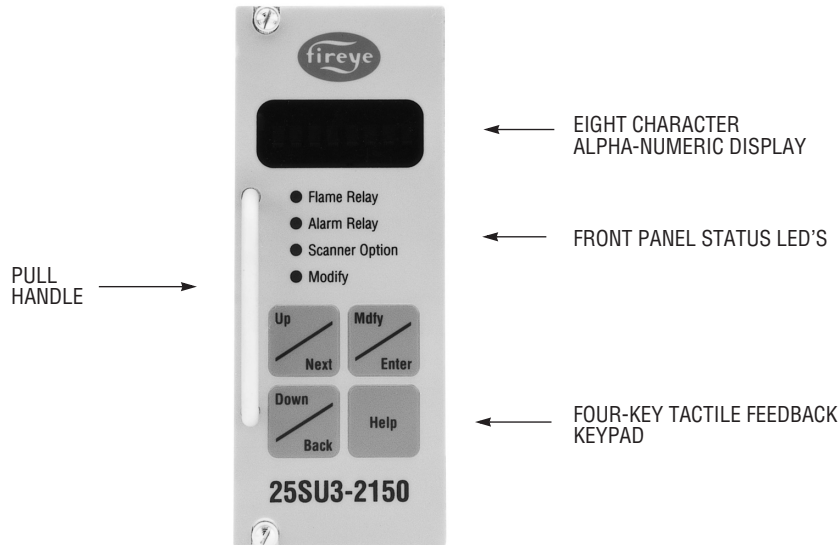

EIGHT CHARACTER ALPHA-NUMERIC DISPLAY

Information on the set-up and operation of the 25SU3-2150 is displayed on a high intensity eight character alpha-numeric display. The operating parameters and system setpoints are displayed using a mnemonic code, up to eight characters in length, which serve as an abbreviated descriptor for that value. A full length descriptor providing a detailed description of each value is also available via the “Help” key. When powered up, the display will show the flame signal for scanner A.

Note: As part of the internal self-check routines, it is normal to see a slight activity in some of the unused segments of the alpha-numeric display at all times.

STATUS LED'S: Four (4) status LED's are located on the front panel to provide the following information:

Flame Relay LED: This LED is lit when the flame relay is energized.

Alarm Relay LED: This LED indicates the status of the alarm relay or annunciates a Shutter Check Failure. Refer to Shutter Check Fail option, and Marginal Alarm sections under Setpoints Menu for details.

*Note: **NOW OBSOLETE*



Scanner Option LED: This LED indicates which Scanner Logic Option is selected.

- **Steady State** —Scanner Logic Option 1 is selected. (Terminal Z16 to Z12 is open).
- **Pulsing** —Scanner Logic Option 2 is selected. (Terminal Z16 to Z12 is closed).

Modify LED: This LED is lit when the user is in the Setpoints menu and the “Modify/Enter” key has been pressed to change the value of a setpoint.

*Note: As an indication that scanner self-check is occurring, any **de-energized** status LEDs will blink “ON” briefly (less than 1/2 second) each time the scanner self-check occurs. The self-check interval is a nominal 4 seconds. As part of the “intelligent” self-check circuitry, under certain operating conditions (e.g. decreasing flame signal) this interval can be longer.*

FOUR KEY KEYPAD

The 25SU3-2150 has four (4) positive action embossed, membrane keys with tactile feedback to review and modify the setpoints and operating parameters of the amplifier. The keys are multi-functional in that each key performs double duty, depending on when they are pressed.

Up/Next key

1. This key will display the next operating parameter or system setpoint and its associated value.
2. When the user is in the “Setpoints” menu and the Modify/LED is on, this key will increase the value associated with that setpoint.

Down/Back key

1. This key will display the previous operating parameter or system setpoint and its associated value.
2. When the user is in the “Setpoints” menu and the Modify/LED is on, this key will decrease the value associated with that setpoint.

Mdfy/Enter key

1. When the user is in the “Status” menu, this key will enter the “Setpoints” menu.
2. When the user is the “Setpoints” menu, after entering the password this key will allow the user to modify the value of that setpoint. The “Modify” LED will light.

Help

1. This key will display the full length descriptor associated with the mnemonic code of each operating parameter and setpoint. After two minutes, the display will return to the mnemonic.
2. When the user is in the “Setpoints” menu, pressing this key **twice** will return to “Status” menu.

OPERATION

The key feature of the 25SU3-2150 amplifier is its ability to properly detect and discriminate between flame on and flame off conditions. The 25SU3-2150 has the ability to display the actual flame signal pulses received from the flame scanners. The user programs the pull in and drop out values for the flame relay based on the observed signals from one or more scanners (see Scanner Logic Option).

Flame Relay: If the flame relay is de-energized, the 25SU3-2150 will not energize the flame relay until the flame signal (based on the logic configuration selected via the Scanner Logic Option) is above the “Flame Relay On Threshold” setpoint (RF ON) for the programmed Flame Relay Delay On time (RF DLY). Once energized, the flame relay will not be de-energized until the average flame signal falls below the Flame Relay Off Threshold setpoint (RF OFF) for the length of the Flame Failure Response Time setpoint (FFRT).

Alarm Relay: The alarm relay is energized if the flame signal (based on the logic configuration selected via the Scanner Logic Option) is below the Marginal Alarm Threshold (MRG ALM) for at least ten (10) seconds and the flame relay is energized.



Self-Check Failure: The 25SU3-2150 offers a selection on how the amplifier responds in the event of a self-check failure of the connected flame scanner(s). Refer to Self-Check Fail Option (SELF CHK) under Setpoints Menu for details.

STATUS AND SETPOINTS MENU

The 25SU3-2150 will display the operating parameters and system setpoints under the Status menu and Setpoints menu respectively. In addition, the user can modify the values of the system setpoints. For all operating parameters and system setpoints, the display will show the mnemonic code, followed by its associated value. If the **HELP** key is pressed, the full length descriptor associated with the operating parameter or setpoint will be displayed, followed by its associated values.

Example: In the Status menu, the display shows A=486. If the **HELP** key is pressed, the display will show SCANNER A PULSE RATE (full length descriptor) followed by 486 (value).

Press the **MDFY/ENTER** key to switch from the Status menu to the Setpoints Menu.

PRESS THE “HELP” KEY TWICE TO SWITCH FROM THE SETPOINTS MENU TO THE STATUS MENU.

STATUS MENU

The Status menu displays the current operating parameters of the 25SU3-2150.

Note: These status parameters cannot be modified.

THE STATUS MENU

Mnemonic	Full Length Descriptor	Value
A = XXXX	SCANNER A PULSE RATE	Actual flame signal pulses from Scanner A. Range = 0-1900 pulses.
B = XXXX	SCANNER B PULSE RATE	Actual flame signal pulses from Scanner B. Range = 0-1900 pulses.
RF RLY	FLAME RELAY STATUS	ON / OFF
ALM RLY	ALARM RELAY STATUS	ON / OFF
4-20 OUT	ANALOG OUTPUT	4-20 mA output proportional to the flame signal(s) based on the selected Scanner Logic Option. Value displayed in percent (%). Output scaled under “Setpoints” menu.
SCN A CHK	SCANNER A SELF-CHECK PULSES	Flame pulses from scanner A detected during self-check period.
SCN B CHK	SCANNER B SELF-CHECK PULSES	Flame pulses from scanner B detected during self-check period.

SETPOINTS MENU

The Setpoints menu contains the various system setpoints that are configurable by the user. Following is a description of some of the system setpoints.

Scanner Logic Option (SCN OPT): This setpoint allows the user to combine the flame signal pulses from the connected scanners in a variety of Logical Configurations (see below) to control the flame relay. Each Scanner Logic Option has its own separate flame on (RF ON), flame off (RF OFF), marginal alarm (MRG ALM), flame failure response time (FFRT), and 4-20 mA scaling (4-20 RNG) setpoints.

It is not necessary to have two scanners connected to utilize the **Scanner Option 1 & 2 and the Logic Options** features. This example will clarify this. There is a need to discriminate between pilot and main flame with one scanner. Usually pilot flame provides considerably less signal than main flame and with conventional controls it would require connecting two scanners, each with different sensitivity settings. The burner management system would then switch out the pilot scanner during the main flame stabilization period, and it would then be up to the main flame scanner to detect the



main flame. With the 25SU3-2150 and one scanner connected, Scanner Option 1 (**SCN OPT1**) would have Logic Option 1, “A ONLY” and the thresholds would be set to detect the pilot flame at one signal level. Scanner Option 2, “A ONLY,” and its thresholds would be set to detect the main flame at a higher signal level. During the main flame stabilization period the burner management system would then switch from Scanner Option 1 to Scanner Option 2. If the main flame did not provide signal that was above Logic Option 2's flame off threshold the system would indicate a flame failure.

- A ONLY** - Pulses from Scanner A determine the Flame Relay status. Scanner B is ignored.
- B ONLY** - Pulses from Scanner B determine the Flame Relay status. Scanner A is ignored.
- A AND B** - Pulses from both scanners must be above the pull-in threshold to energize the Flame Relay. Pulses from either scanner below the drop-out threshold will drop the flame relay out.
- A OR B** - Pulses from either scanner must be above the Flame Relay pull-in threshold to energize the Flame Relay and pulses from both must be below the drop-out threshold to de-energize the Flame Relay.
- A XOR B** - Pulses from both scanners must be above the Flame Relay threshold to energize the Flame Relay. Pulses from both scanners must be below the drop-out threshold to de-energize the Flame Relay.
- A PLUS B** - Pulses from Scanners A and B are added together. The resulting sum determines the Flame Relay status.

SCANNER USEAGE OPTIONS						
	A ONLY	B ONLY	A AND B	A OR B	A XOR B	A PLUS B
Flame Relay Energized	A > Pull In	B > Pull In	A > Pull In AND B > Pull In	A > Pull In OR B > Pull In	A > Pull In AND B > Pull In	The SUM of A plus B > Pull In
Flame Relay De-energized	A < Drop Out	B < Drop Out	A < Drop Out OR B < Drop Out	A < Drop Out AND B < Drop Out	A < Drop Out AND B < Drop Out	The SUM of A plus B < Drop Out
4-20 mA Output Follows:	A Pulses	B Pulses	The LOWER of A or B Pulses	The HIGHER of A or B Pulses	The LOWER of A or B Pulses	The SUM of A plus B Pulses
IN RESPONSE TO MARGINAL FLAME SIGNAL, THE ALARM RELAY IS ENERGIZED WHEN:						
MARG OPT = EITHER	A < Threshold	B < Threshold	A or B < Threshold	A or B < Threshold	A or B < Threshold	A or B < Threshold
MARG OPT = BOTH	A < Threshold	B < Threshold	A and B < Threshold	A and B < Threshold	A and B < Threshold	A and B < Threshold

	Alarm RELAY Action	Alarm LED Action
Self-Check Fault Scanner A	On/Off 4 sec.	On/Off 4 sec.
Self-Check Fault Scanner B	On/Off 2 sec.	On/Off 2 sec.
Marginal Alarm Scanner A	On Steady (See Note 1)	On/Off 3 sec. (see Notes 1, 2)
Marginal Alarm Scanner B	On Steady (See Note 1)	On/Off 1 sec. (see Notes 1, 2)
NOTE 1: The Self-Check Fault Annunciation takes priority over a Marginal Signal Annunciation.		
NOTE 2: If logic options “A ONLY” or “B ONLY” are selected, the LED will not flash.		

To “Pull-In” the Flame Relay, the scanner signal received must be above the flame relay pull-in threshold for the required amount of user selected delay on time.

To “Drop-Out” the Flame Relay, the scanner signal received must be below the flame relay drop-out threshold for the required “flame failure response time.”

Flame Relay On Threshold (RF ON): The flame relay is energized when the flame signal (based on the logic configuration selected via the Scanner Logic Option) is above this setpoint.

Flame Relay Off Threshold (RF OFF): The flame relay is de-energized when the flame signal (based on the logic configuration selected via the Scanner Logic Option) is below this setpoint.

The above setpoints (RF ON and RF OFF) select the pull-in and drop-out values of the flame relay, allowing the amplifier to accurately discriminate between flame on/flame off conditions regardless of the flame on to flame off ratio. An attempt should be made to maintain a pull-in/drop-out ratio of no less than 2:1 in order to achieve satisfactory performance.



WARNING: When installing self-checking ultra-violet flame scanners (e.g. 45UV5-1000EC), the sensitivity of the UV tube may drop within 24-48 hours after initial installation or after returning the scanner to service after extended periods of non-use. This phenomenon is due to “burn-in” of the UV tube. This loss of sensitivity would result in a drop in flame signal from the UV scanner which could affect the pull-in or drop-out of the flame relay. The user should check on the flame signal strength of the UV scanner 1-2 days after initial installation (or a return to service) to ensure an adequate flame signal.

Flame Failure Response Time (FFRT): The flame relay is de-energized when the flame relay drops below the Flame Relay Off Threshold setpoint (RF OFF) for the length of the FFRT time. Selections are from 1 to 6 seconds with a separate selection for the 45FS1**/45UVFS1** scanner (45FS1**). When the 45FS1**/45UVFS1** scanners are used, the total FFRT is **additive** between the 25SU3-2150 and the 45FS1**/45UVFS1** scanner. The FFRT time of the 25SU3 -2150 is considered instantaneous for the selection 45FS1**. The total FFRT would then be the FFRT setpoint of the 45FS1**/45UVFS1** scanner. Refer to Bulletin CU-32 for additional information.

4-20 mA Output Range (4-20 RNG): This setpoint will scale the 4-20 mA output signal to match the anticipated flame signal for each Scanner Logic Option. For example, if 0-500 is selected, at 250 pulses, the output will be 12 mA. The available selections are 0-125, 0-250, 0-500, 0-750, 0-1000, 0-1500, 0-2000. This allows proper scaling for each scanner/logic option selection.

Flame Relay Delay On (RF DLY): The flame relay is not energized until the flame signal (based on the logic configuration selected via the Scanner Logic Option) is above the “Flame Relay On Threshold” setpoint (RF ON) for the time programmed under this setpoint (RF DLY). Allowable values are 0 to 10 seconds. This setpoint helps to ensure a stable flame signal before energizing the flame relay.

Marginal Alarm Threshold (MRG ALM): The alarm relay is energized when the flame signal (based on the logic configuration selected via the Scanner Logic Option) is below this setpoint and the flame relay is energized. The flame signal must be below this setpoint for at least ten (10) seconds before the alarm relay is energized. The Self-Check Failure annunciation takes priority over the Marginal Alarm annunciation.

Marginal Alarm Option (MRG OPT): The user may select how the alarm relay and LED will respond to pulses from scanners A and B. If “**EITHER**” is selected, the alarm relay and LED will energize when *either* scanner A or scanner B pulses drop below the marginal alarm threshold for 10 seconds. If “**BOTH**” is selected, the alarm relay and LED will energize only when *both* scanner A and scanner B pulses drop below the marginal alarm threshold for 10 seconds.

When a marginal alarm condition occurs, the alarm relay will energize. If the signal from scanner A is marginal, the alarm LED will flash a **3 second** intervals. If the signal from scanner B is marginal, the alarm LED will flash at **1 second** intervals.

The default selection will be “**BOTH**” (A and B pulses). When the logic options “**A ONLY**” or “**B ONLY**” are selected, only the pulses from the appropriate scanner will be considered, regardless of selection. . . . *Note: **NOW OBSOLETE*



Self-Check Fail Option (SELF CHK): This setpoint allows the user to select how the amplifier responds in the event of a self-check failure of the connected flame scanner(s).

If the SELF CHK Setpoint is programmed YES: The 25SU3-2150 will annunciate the failure (Alarm LED blinks and Alarm Relay pulses at the interval indicated on page 12). and disregard the flame signal from the scanner with the self-check failure. If the Scanner Logic Option is selected for only the “failed” scanner (e.g. SCN A ONLY or SCN B ONLY), the 25SU3-2150 will de-energize the flame relay. If the Scanner Logic Option is using the signal from two scanners (e.g. A PLUS B or A OR B), the flame relay will remain energized if the flame signal from the remaining “good” scanner is above the Flame Relay Off Threshold setpoint (RF OFF).

If the SELF CHK Setpoint is programmed NO: The 25SU3-2150 will annunciate the failure (Alarm LED blinks and Alarm Relay pulses at the interval indicated on page 14) but continue to use the flame signal from the “failed” scanner in the decision to energize or de-energize the flame relay. The flame relay will remain energized as long as the flame signal (based on the logic configuration selected via the Scanner Logic Option) is above the Flame Relay Off Threshold setpoint (RF OFF).

In the event of a self-check failure, the message CHK FL A (or B) (Self-Check Failure Scanner A [or B]) will be displayed on the 8 character LED alpha-numeric display.



WARNING: To ensure fail-safe operation, the SELF CHK setpoint must be programmed YES. Always refer to and comply with prevailing approval codes/safety codes before programming the SELF CHK setpoint.

THE STATUS AND SETPOINT GROUPS

THE STATUS MENU

MNEMONIC	DESCRIPTOR	VALUE
A = XXXX	SCANNER A PULSE RATE	Scanner A input flame signal pulse rate, 0-1900 pulses/sec.
B = XXXX	SCANNER B PULSE RATE	Scanner B input flame signal pulse rate, 0-1900 pulses/sec.
RF RLY	FLAME RELAY STATUS	'OFF' / 'ON'
ALM RLY	ALARM RELAY STATUS	'OFF' / 'ON'
4-20 OUT	ANALOG OUTPUT	Flame signal strength, 0-100%.
SCNA CHK	SCANNER A SELF-CHECK PULSES	Flame pulses from scanner A detected during self-check close period.
SCNB CHK	SCANNER B SELF-CHECK PULSES	Flame pulses from scanner B detected during self-check close period.

THE SETPOINT MENU

Factory Presets: The 25SU3-2150 is shipped with the following Preset values for the SETPOINT GROUP.

SETPOINT	PRESET VALUE	
SCN OPT1	A OR B	SCANNER LOGIC OPTION 1 SETPOINTS
RF ON 1	400 PULSES/SEC	
RF OFF 1	200 PULSES/SEC	
MRG ALM1	300 PULSES/SEC	
FFRT 1	1 SEC (SEE WARNING)	
4-20 RG1	0-250 PULSES/SEC (full scale)	
MRG OPT1	BOTH	
SCN OPT2	A OR B	SCANNER LOGIC OPTION 2 SETPOINTS
RF ON 2	400 PULSES/SEC	
RF OFF 2	200 PULSES/SEC	
MRG ALM2	300 PULSES/SEC	
FFRT 2	4 SEC (SEE WARNING)	
4-20 RG2	0-250 PULSES/SEC (full scale)	
MRG OPT2	BOTH	
SELF CHK	YES	
RF DLY	0 SEC	
CTS DLY	50 mSec	COMMUNICATION SETPOINTS
CMM PROT	A-B	
MAST NUM	255 = *377	
DEV NUM	1 = *1	
BAUD	1200 baud	
REV NUM	7 (or latest)	
LV1 PASS	2	
LV2 PASS	5	
SYSTEM TEST	OFF	
ALM OPT	EITHER	
RST MSG	AUTO	
SCN TYPB	45UV5	
SCN TYPA	45UV5	

FACTORY DEFAULT VALUES

In the event of an internal fault, scanner option (SCN OPT) will default to “A AND B”, Flame ON (RF ON) to 1895 pulses/sec, Flame OFF (RF OFF) to 1890 pulses/sec, SCN TYPB and SCN TYPA to “none”, FFRT1 and FFRT2 to “1 second”.



WARNING: As delivered from factory, FFRT1 and FFRT2 are configured for 1 second and 4 seconds respectively. THE FFRT SHOULD BE SELECTED TO COMPLY WITH APPLICABLE SAFETY CODES AND REGULATIONS



25SU3-2150 SETPOINTS AND ALLOWABLE VALUES

MNEMONIC	DESCRIPTION	VALUE
SCN OPT1	SCANNER USAGE OPTIONS 1	One of the following: A ONLY A OR B B ONLY A AND B A PLUS B A XOR B
RF ON 1	FLAME RELAY ON THRESHOLD 1	Scanner pulse rate (pps) required to turn flame relay ON (5 -1900)
RF OFF 1	FLAME RELAY OFF THRESHOLD 1	Scanner pulse rate (pps) required to turn flame relay OFF (5 -1900)
MRG ALM1	MARGINAL ALARM THRESHOLD 1	Threshold level required to energize marginal flame relay (5-1900 pps).
FFRT 1	FLAME FAILURE RESPONSE TIME 1 (SEE WARNING)	Time to flame relay off 4 secs 1 secs 5 secs 2 secs 6 secs 3 secs 45FS1** (For use with 45FS1** or 45UVFS1** scanners only).
4-20 RG1	4-20 MA OUTPUT PULSE RANGE 1	Scalable analog output range of flame intensity: 0-125 0-250 0-500 0-750 0-1000 0-1500 0-2000
MRG OPT1	MARGINAL ALARM OPTION 1	One of the following: BOTH SCANNERS EITHER SCANNER
SCN OPT2	SCANNER USAGE OPTIONS 2	One of the following: A ONLY A OR B B ONLY A AND B A PLUS B A XOR B
RF ON 2	FLAME RELAY ON THRESHOLD 2	Scanner pulse rate (pps) required to turn flame relay ON (5-1900)
RF OFF 2	FLAME RELAY OFF THRESHOLD 2	Scanner pulse rate (pps) required to turn flame relay OFF (5-1900)
MRG ALM2	MARGINAL ALARM THRESHOLD 2	Threshold level required to energize marginal flame relay (5-1900pps)
FFRT 2	FLAME FAILURE RESPONSE TIME 2 (SEE WARNING)	Time to flame relay off 4 secs 1 secs 5 secs 2 secs 6 secs 3 secs 45FS1 (For use with 45FS1 or 45UVFS1 scan- ners only).
4-20 RG2	4-20 MA OUTPUT RANGE 2	Scalable analog output range of flame intensity: 0-125 0-250 0-500 0-750 0-1000 0-1500 0-2000
MRG OPT 2	MARGINAL ALARM OPTION 2	One of the following: BOTH SCANNERS EITHER SCANNER

*Note: **NOW OBSOLETE*



25SU3-2150 SETPOINTS AND ALLOWABLE VALUES (continued)

SELF CHK	SELF-CHECK FAIL OPTION	Yes or No. De-energize flame relay on scanner self-check failure.
RF DLY	FLAME RELAY DELAY ON	Consecutive secs. for flame signal to be above ON threshold to Flame Relay ON. Range: 0 - 10 secs.
CTS DLY	CLEAR TO SEND DELAY	Delay before response message sent; 0-255 milli-seconds
CMM PROT	COMMUNICATION PROTOCOL	Communication protocol selected (DF1 or MODBUS)
MAST NUM	MASTER NUMBER DECIMAL = *OCTA	Master number; multi-master communication system; 0-255
DEV NUM	DEVICE NUMBER DECIMAL = * OCTA	Local address number; 1-254.
BAUD	BAUD RATE	Baud rate for communication: 300 1200 2400 4800 9600
REV NUM	REVISION NUMBER	Software revision number
LV1 PASS	ENTER LEVEL 1 PASSWORD	Storage for operator entered password.
LV2 PASS	ENTER LEVEL 2 PASSWORD	Storage for operator entered password.
SET LVL1	SET LEVEL 1 PASSWORD	Storage for user-programmed password.
SET LVL2	SET LEVEL 2 PASSWORD	Storage for user-programmed password.
SYS TEST	SYSTEM TEST	System Test is: 2 Password Required; No 5 minute time-out after last key stroke.
ALM OPT	ALARM OPTION	Defines the function of the alarm relay. Choices: MGR ONLY, SLF ONLY, EITHER.
RST MSG	RESET SELF-CHECK FAILURE MESSAGE	Method to clear self-check failure message. Choices: AUTO or MANUAL.
SCN TYPB Note 1	SCANNER TYPE ATTACHED TO "B"	Flame Scanner Model Choices: 45UV5, 45RM1**, 45RM2**, 45RM4**, 45FS1** (applies also to 45UVFS1**), other, none.
SCN TYPA Note 1	SCANNER TYPE ATTACHED TO "A"	Flame Scanner Model Choices: 45UV5, 45RM1**, 45RM2**, 45RM4**, 45FS1** (applies also to 45UVFS1**), other, none.

***Note 1:** Fireye Signature™ Scanners, 45FS1** and 45UVFS1** should not be combined with analog scanners, 45UV5, 45RM1**, 45RM2** and/or 45RM4** operating together in the same "scanner usage option". You may, however, have a Signature scanner in one "scanner usage option", and an analog scanner in the other.*

PASSWORD PROTECTION

The 25SU3-2150 comes from the factory with a default password set at 2, 5 (LV1 PASS = 2 and LV2 PASS = 5). After powering up the unit, it will be necessary to enter this password before any setpoint parameter can be modified or before any new password can be put in.

ENTERING THE FACTORY DEFAULT PASSWORD LV1 PASS = 2 and LV2 PASS = 5

After the unit has been powered up, PRESS the **Mdfy/Enter** key to enter the SETPOINT GROUP.

1. PRESS the **Up/Next** key until **LV1 PASS 0** is displayed
PRESS the **Mdfy/Enter** key. The **MODIFY LED** on the front panel will illuminate.
PRESS the **Up/Next** key until 2 appears in the display.
PRESS the **Mdfy/Enter** key. The display shows LV1 PASS 2. The **MODIFY LED** on the front panel goes out.
2. PRESS the **Up/Next** key until LV2 PASS 0 is displayed.
PRESS the **Mdfy/Enter** key. The **MODIFY LED** on the front panel will illuminate.
PRESS the **Up/Next** key until 5 appears in the display.
PRESS the **Mdfy/Enter** key. The display shows LV2 PASS 5. The **MODIFY LED** on the front panel goes out. After entering the password, the user can now modify any of the setpoint values.

Note: **NOW OBSOLETE



CHANGING THE PASSWORD

Once the proper passwords have been entered, the mnemonic codes displayed for password protection **will change to** Set Level 1 (SET LVL 1) and Set Level 2 (SET LVL 2) followed by their respective passwords. The user can now change either of the two password levels. Following is an example to change the Level 1 password from 02 to 10, and the Level 2 password from 05 to 20:

1. PRESS the **Up/Next** key until SET LV1 2 is displayed.
PRESS the **Mdfy/Enter** key. The **MODIFY LED** on the front panel will illuminate.
PRESS the **Up/Next** key until 10 appears in the display.
PRESS the **Mdfy/Enter** key. The display shows SET LV1 10. The **MODIFY LED** on the front panel goes out.
2. PRESS the **Up/Next** key until SET LV2 5 is displayed.
PRESS the **Mdfy/Enter** key. The **MODIFY LED** on the front panel will illuminate.
PRESS the **Up/Next** key until 20 appears in the display.
PRESS the **Mdfy/Enter** key. The display shows SET LV2 20. The **MODIFY LED** on the front panel goes out.

A new password has now been set to LV1 PASS = 10 and LV2 PASS = 20.

REMOVING PASSWORD PROTECTION

The user can remove software password protection by setting both Level 1 password and Level 2 password to zero. Any user will then be able to modify any setpoint without entering a new password. When the password protection has been removed, the mnemonic codes are SET LVL1 and SET LVL 2, followed by the value zero. The user can enable the password protection mode by changing the Level 1 and/or Level 2 password to a value other than zero.

FIVE MINUTE TIME-OUT

Once the password has been entered or set, there is a five (5) minute time-out period after any key is pressed, within which the user can modify any setpoint parameter without having to re-enter the password. If no keys are pressed for a period of five minutes, then the password must be entered to gain access to the modify mode.

EXAMPLE: The user has just entered the PASSWORD. The user will now have five minutes to Press a Key (e.g. make a modification to a setpoint parameter) before the amplifier will revert back to the STATUS GROUP, and the PASSWORD will have to be re-entered.

If the user PRESSES a KEY within the five minute period, then the user will have five minutes from the latest key stroke to PRESS a KEY before the amplifier will revert back to the STATUS GROUP, and a PASSWORD will have to be re-entered.

SYSTEM TEST 2 — BYPASS TIME-OUT

Once the user has entered the PASSWORD, modifications can be made to any of the SETPOINT parameters. Modifications can continue to be made as long as the user PRESSES a KEY within the five minute time-out limit. There may be a situation in which the user may enter the PASSWORD, make the modifications required, and may not want to leave the unit capable of undergoing further modifications by others who could make modifications without entering the PASSWORD within the five minute time-out period.

SOLUTION: The user can enter the PASSWORD, make the modifications, and then go into SYSTEM TEST 2, so that there is no five minute time-out. The PASSWORD must be entered again before modifications can be made.

First, Go to the SETPOINT Group from the STATUS GROUP by Pressing the Modify/Enter key.

- PRESS the **Up/Next** key until SYS TEST OFF is displayed.
- PRESS the **Mdfy/Enter** key. The **MODIFY LED** on the front panel will illuminate.
- PRESS the **Up/Next** key until 2 appears in the display.
- PRESS the **Mdfy/Enter** key. The **MODIFY LED** on the front panel will go out.



EXAMPLE — PROGRAMMING SETPOINTS

To help the user in making SETPOINT changes via the MODIFY MODE, the following example with the key stroke sequence is given:

Set-up the following:

SCN OPT2 (A AND B)
RF ON 2 (500)
RF OFF 2 (250)
MRG ALM2 (300)
FFRT 2 (4 SECS)
4-20 RNG2 (1000)
MRG OPT1 (EITHER)

1. PRESS the **Mdfy/Enter** key. The display will show the Scanner Option chosen. If SCN OPT2 is displayed, Go to Step 2. Otherwise, PRESS THE **Up/Next** key until SCN OPT2 is displayed.
2. If A AND B is displayed, then Go to Step 3. Otherwise, PRESS the **Mdfy/Enter** key. The **MODIFY LED** on the front panel will illuminate. PRESS the **Up/Next** key until A AND B is displayed. PRESS the **MDFY/Enter** key. The **MODIFY LED** will go out. The display will show SCN OPT2 A AND B.
3. PRESS the **Up/Next** key until RF ON 2 and a numerical value is displayed. If the numerical value is 500, then Go to Step 4. Otherwise, PRESS the **Mdfy/Enter** key. The **MODIFY LED** will illuminate. PRESS either the **Up/Next** key or the Down/Back key until a value of 500 is displayed. PRESS the **MDFY/Enter** key. The **MODIFY LED** will go out. The display shows RF ON 2 500.
4. PRESS the **Up/Next** key until RF OFF 2 and a numerical value is displayed. If the numerical value is 250, then Go to Step 5. Otherwise, PRESS the **Mdfy/Enter** key. The **MODIFY LED** will illuminate. PRESS either the **Up/Next** key or the Down/Back key until a value of 250 is displayed. PRESS the **MDFY/Enter** key. The **MODIFY LED** will go out. The display shows RF OFF 2 250.
5. PRESS the **Up/Next** key until MRG ALM2 and a numerical value is displayed. If the numerical value is 300, then Go to Step 6. Otherwise, PRESS the **Mdfy/Enter** key. The **MODIFY LED** will illuminate. PRESS either the **Up/Next** key or the Down/Back key until a value of 300 is displayed. PRESS the **MDFY/Enter** key. The **MODIFY LED** will go out. The display shows MRG ALM2 300.
6. PRESS the **Up/Next** key until FFRT2 and the number of seconds appears on the display. If the time is 4 sec, stop here. Otherwise, PRESS the **Mdfy/Enter** key. The **MODIFY LED** will illuminate. PRESS either the **Up/Next** key or the Down/Back key until 4 sec is displayed. PRESS the **MDFY/Enter** key. The **MODIFY LED** will go out. The display will show FFRT2 4 SEC.
7. PRESS the **Up/Next** key until 4-20 RNG2 and a numerical value is displayed. If the numerical value is 0-1000, stop here. Otherwise, PRESS the **Mdfy/Enter** key. The **MODIFY LED** will illuminate. Press either the **Up/Next** key or the Down /Back key until 0-1000 is displayed. PRESS the **Mdfy/Enter** key. The **MODIFY LED** will go out. The display will show 4-20 RNG2 0-1000.
8. PRESS the **Up/Next** key until MRG OPT2 (and choice) appears on the display. If the choice displayed is "EITHER," stop here. If the choice displayed is "BOTH," PRESS the **Mdfy/Enter** key. The **MODIFY LED** will illuminate. Press either the **Up/Next** key or the Down/Back key until "EITHER" is displayed. PRESS the **Mdfy/Enter** key. The **MODIFY LED** will go out. The display will show MRG OPT2 EITHER.
9. TO EXIT THE SETPOINT GROUP AND RETURN TO THE STATUS LOOP, PRESS THE "HELP" KEY TWICE.

MOUNTING, GROUNDING AND SHIELDING THE 25SU3-2150

The Fireye 25SU3-2150 and associated rack is designed to be mounted in a metal enclosure where the product will reside permanently. Proper shielding of the rack must be observed.

ELECTRICAL WIRING DIAGRAMS

FIGURE 6. GENERAL WIRING DIAGRAM OF TYPE F CONNECTOR (RACK BACK VIEW), 25SU3 -2150

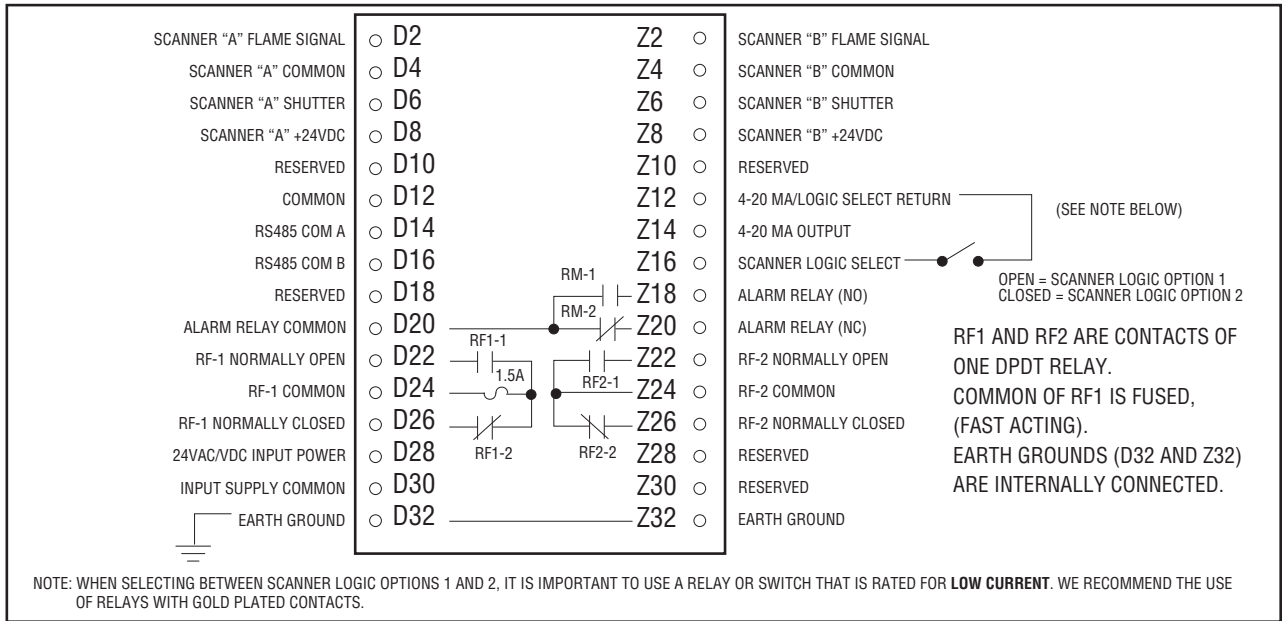

CAUTION: Terminal D32 or Z32 must be connected to a good earth ground. The scanner cable shield (cable P/N 59-491) is connected to the shield bus bar/filter board assembly at the rack connector.

RACK CONNECTOR KIT DETAILS P/N 61-6898-1**:

The electrical interference immunity of the 25SU3-2150 is due in part to the EMI Filter Board / bus bar assembly (P/N 61-6898-2**) which is part of the Rack Connector Kit. The bus bar is necessary for proper shield continuity.

This filter assembly is used to isolate the 120 vac scanner cable power wires (black) when 120 vac scanners are used.

Procedures (refer to wiring diagrams on following pages):

1. The outer shield of Fireeye scanner cable P/N 59-491** must be securely connected to the bus bar assembly with clamps and support sleeves provided with kit.
2. The four scanner cable conductors for a 24 vdc scanner, (45RM4**), are connected directly to the 60-2478 Screw Terminal Assembly. These are the +24vdc (black), common (white), self-check (red), and signal (green) scanner cable conductors.
3. When 120 vac scanners are used (e.g. 45UV5, 45RM1**, 45RM2**), the scanner cable AC power wires (black) are routed through to terminal blocks on the EMI Filter Board / bus bar assembly, and *not* directly to the 60-2478 Screw Terminal Assembly or to the AC power supply (P/N 19MPS, or 19UVPS). The common (white), self-check (red), and signal (green) scanner cable conductors are connected directly to the 60-2478 Screw Terminal Assembly.
4. All other 25SU3-2150 wiring (24 vdc power, earth ground, flame relay, alarm relay, 4-20 mA, logic select, etc.) is connected directly to the 60-2478 Screw Terminal Assembly.

*Note: **NOW OBSOLETE*

FIGURE 7. WIRING DIAGRAM OF EMI RACK FILTER BOARD AND SHIELD BUS BAR ASSEMBLY (P/N 61-6898-2)**

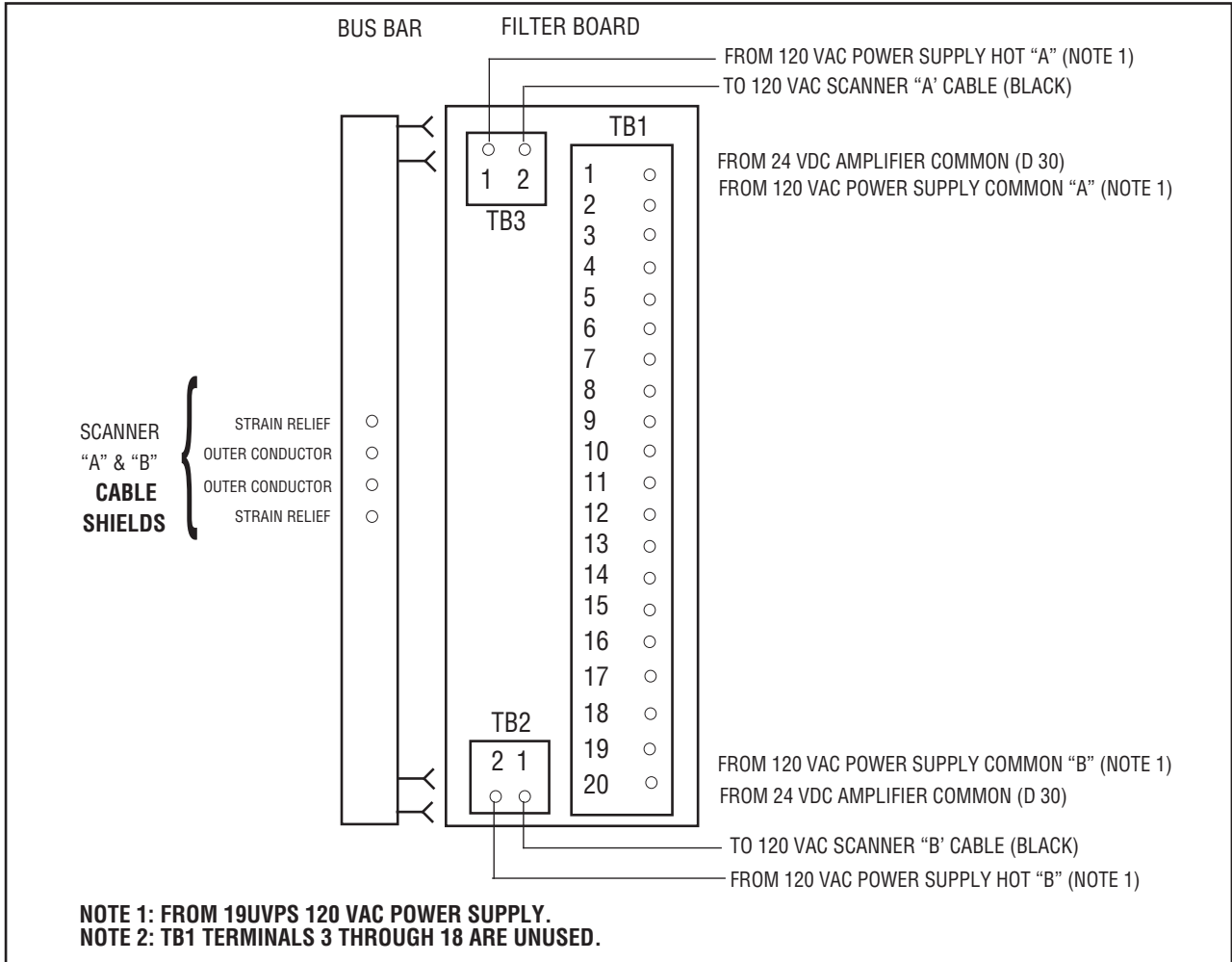

CAUTION: The electrical interference protection system has been carefully engineered and must be installed correctly as described below:

1. Use only 59-491** cable (equipped with braided outer shield over foil).
2. The outer shield must be continuous from the amplifier bus bar to the scanner housing. Use only specified connectors and hardware. See detailed instructions.
3. A terminal used for a scanner cable wire must not be used for any other wire.
4. Terminal D32 or Z32 is grounded to satisfy electrical codes. It should be a good local earth ground through a short path.

Note: **NOW OBSOLETE

FIGURE 8. 25SU3-2150 POWER WIRING DIAGRAM (60-2470 POWER SUPPLY AND THREE 25SU3-2150 AMPLIFIERS)

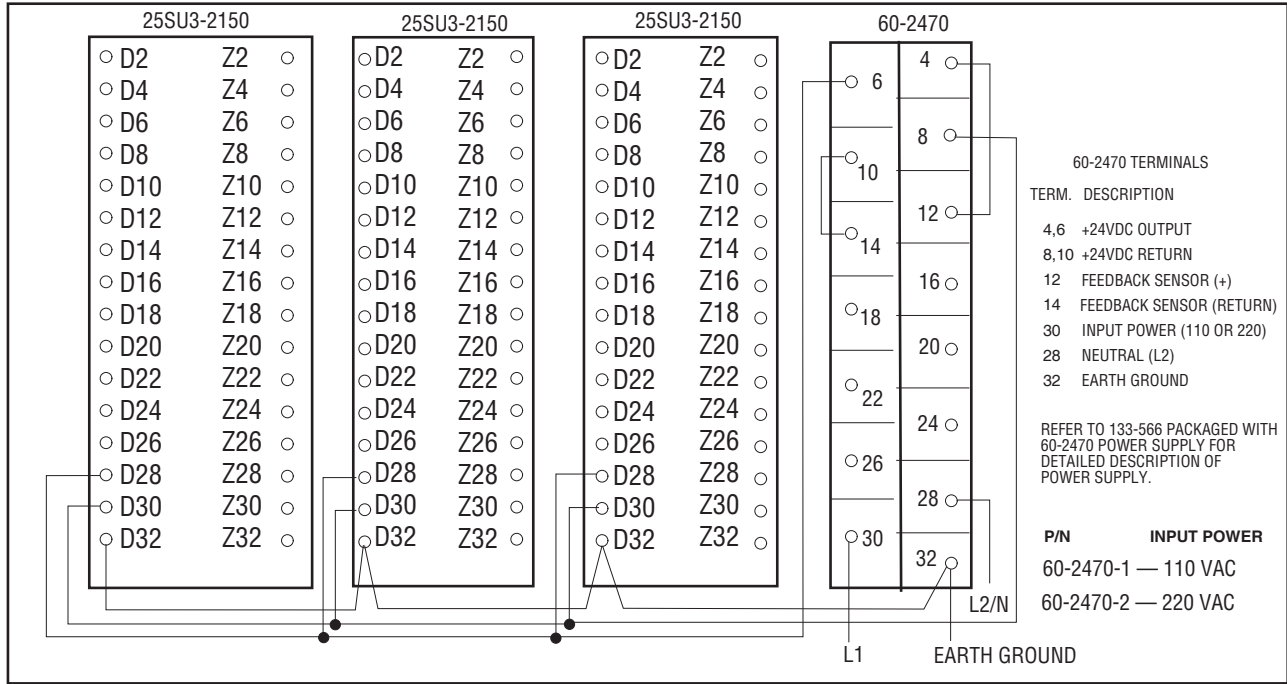
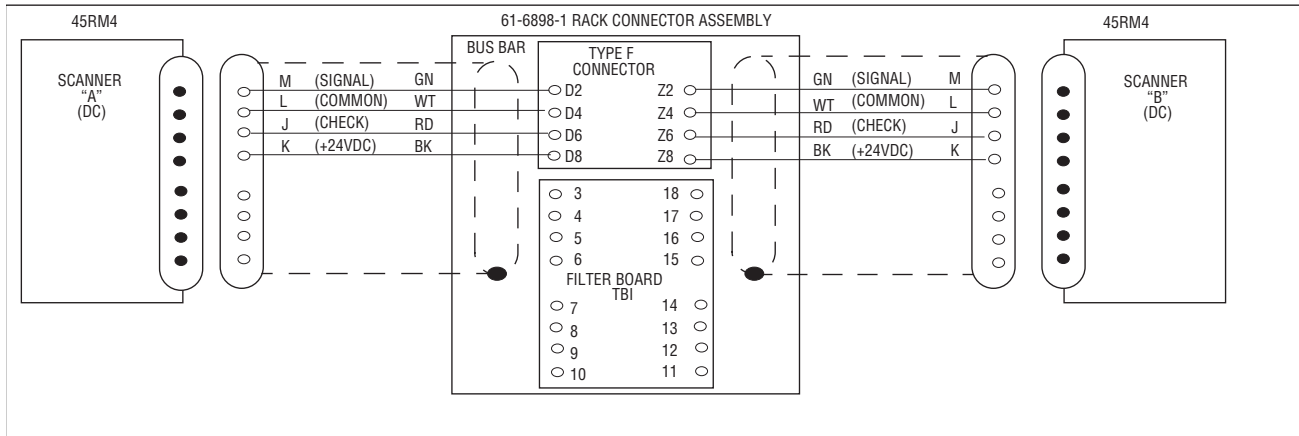

FIGURE 9. 25SU3-2150 SCANNER WIRING DIAGRAM: (25SU3-2150 AMPLIFIER, 45RM4 DC SCANNER WIRING COMBINATIONS^{1, 2})**



¹. Cable shown is P/N 59-491** (4 conductor) contains GN, WT, RD and BK wires.
². Scanners shown are "EC" models.

Note: **NOW OBSOLETE

FIGURE 10. 25SU3-2150 SCANNER WIRING DIAGRAM (25SU3-2150 AMPLIFIER, 19UVPS, 45RM1, 45RM2**, 45UV5 AC SCANNER WIRING COMBINATIONS^{1,2})**

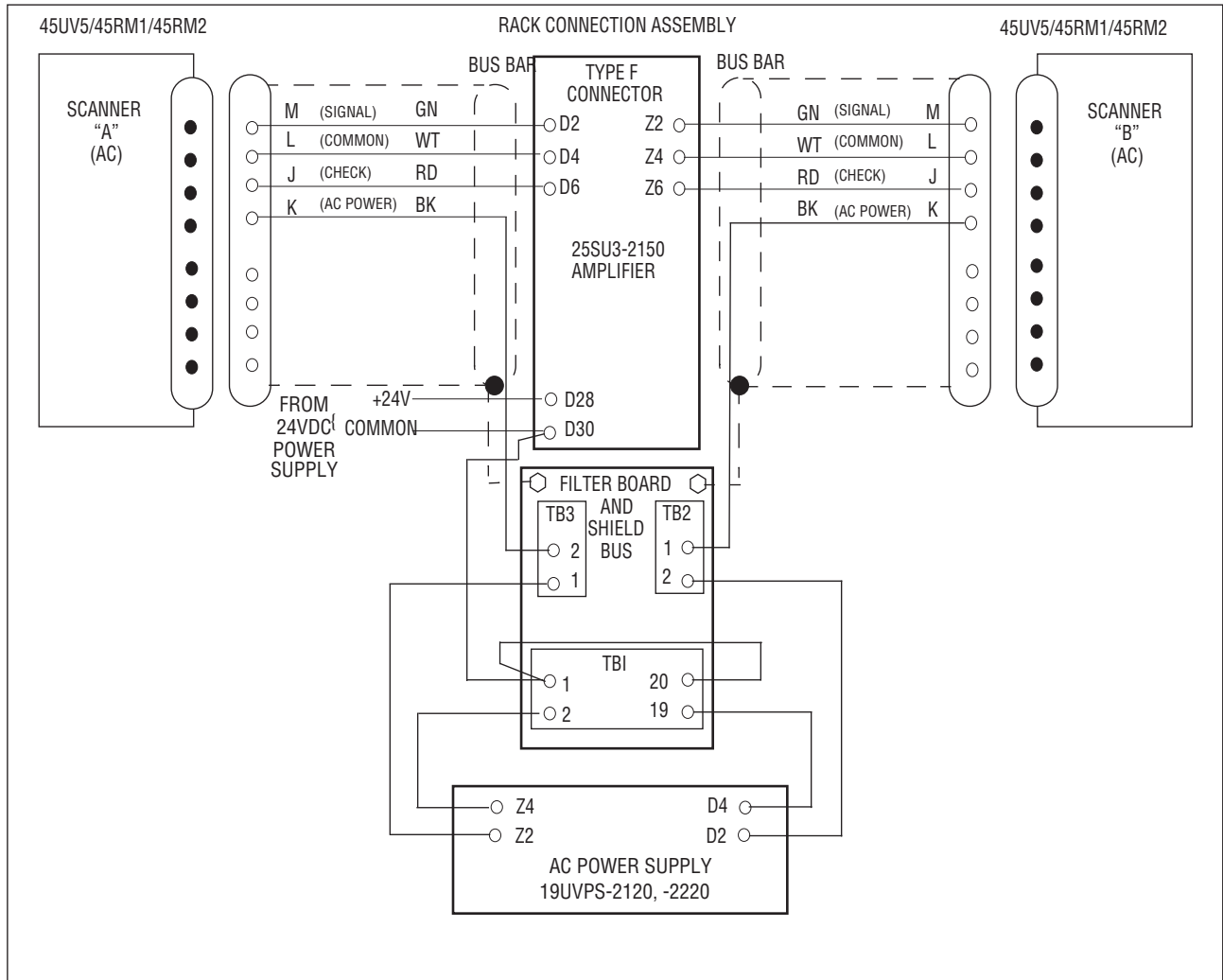

1. Cable shown is P/N 59-491** (4 conductor).

2. Scanners shown are "EC" models.

Note: **NOW OBSOLETE

FIGURE 11. 25SU3-2150 SCANNER WIRING DIAGRAM (TWO 25SU3-2150 AMPLIFIERS, EACH WITH 1 AC AND 1 DC FLAME SCANNER, 19UVPS POWER SUPPLY. THE 24VDC POWER SUPPLY IS NOT SHOWN).

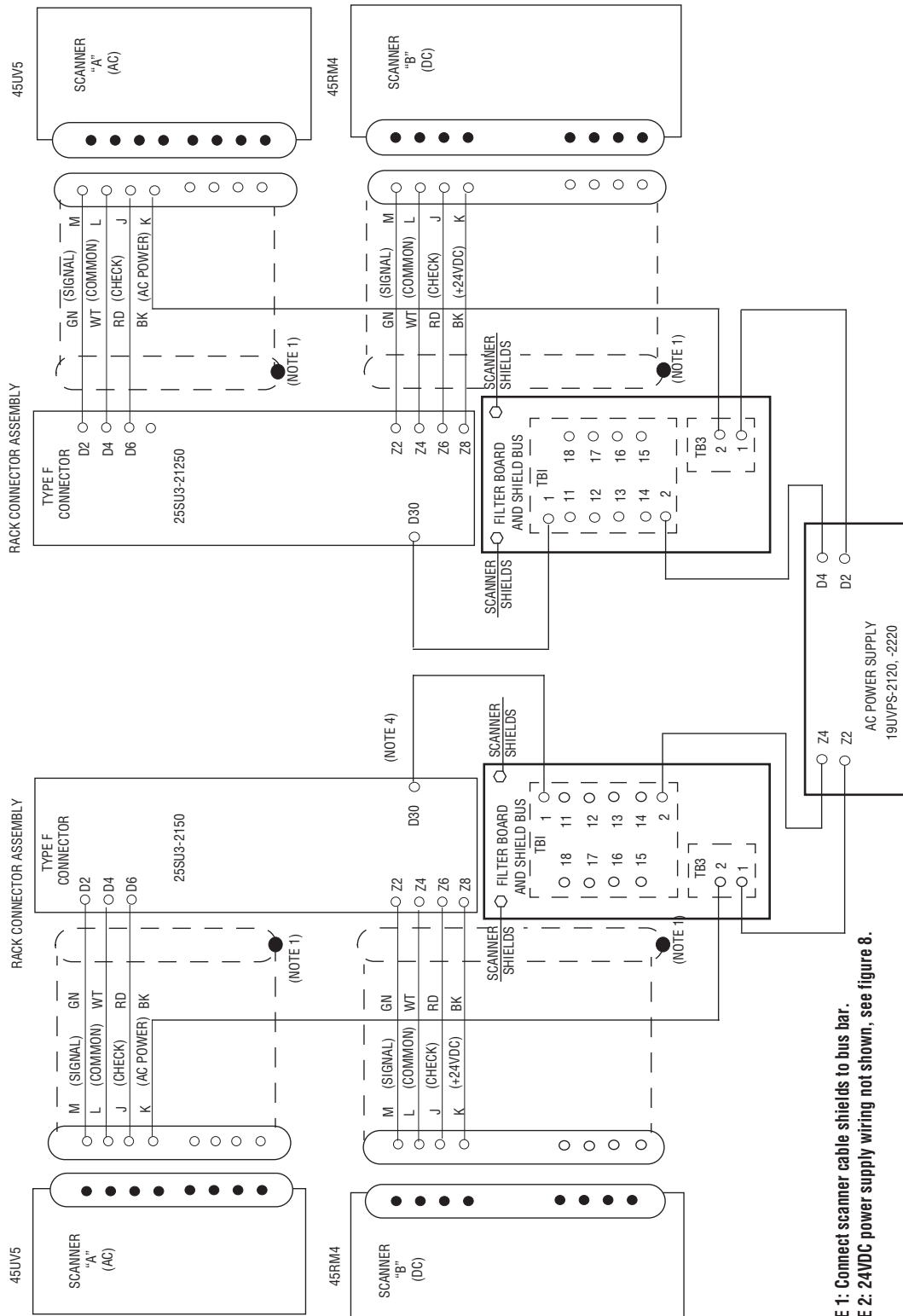

NOTE 1: Connect scanner cable shields to bus bar.
NOTE 2: 24VDC power supply wiring not shown, see figure 8.

FIGURE 12. CONNECTION OF SCANNER CABLE (59-491) TO BUS BAR**

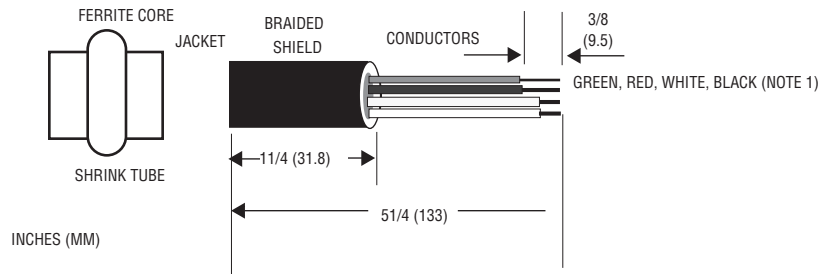

1. CABLE PREPARATION

- A. Slide ferrite iron core and shrink tube (included with PN/ 61-6898-1 connector kit, and with 60-2471-1EC**, -2EC** mounting racks), onto scanner cable. Secure in step 6
- B. Strip outer jacket.
- C. Loosen braiding by pushing back and forth on cable.
- D. Cut back braided shield.
- E. Strip conductor insulation.

NOTE 1: If black conductor is for 45UV5/45RM1**/45RM2**, strip insulation only 3/16" (4.8).

2. SPECIAL PREPARATION OF BLACK WIRE FOR 45UV5/45RM1/45RM2** (120 VAC power, connected to TB2 or TB3)**

- A. Twist strands tightly without crossovers.
- B. Tin strands *lightly*.
- C. Cut to final length 3/16" (4.8mm).
- D. Squeeze square with pliers.

3. ADD SUPPORT SLEEVE OVER BRAIDED SHIELD.

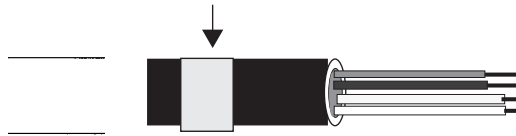

4. FOLD BACK BRAIDED SHIELD OVER SUPPORT SLEEVE AND TRIM FOIL SHIELD.

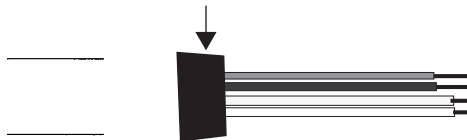

5. SECURE BRAIDED SHIELD AND CABLE JACKET TO BUS BAR. Use two metal clamps, flat washers and extended nuts (provided). (Scanner cables may enter bus bar from either top or bottom and use any two studs for each cable).

6. SLIDE FERRITE IRON CORE WITHIN 6" (152 mm) OF THE RACK CONNECTOR. Secure with shrink tubing provided, or electrical tape.

Note: **NOW OBSOLETE

FIGURE 13. MAKING CONNECTIONS TO RACK CONNECTOR KIT (P/N 61-6898-1)**

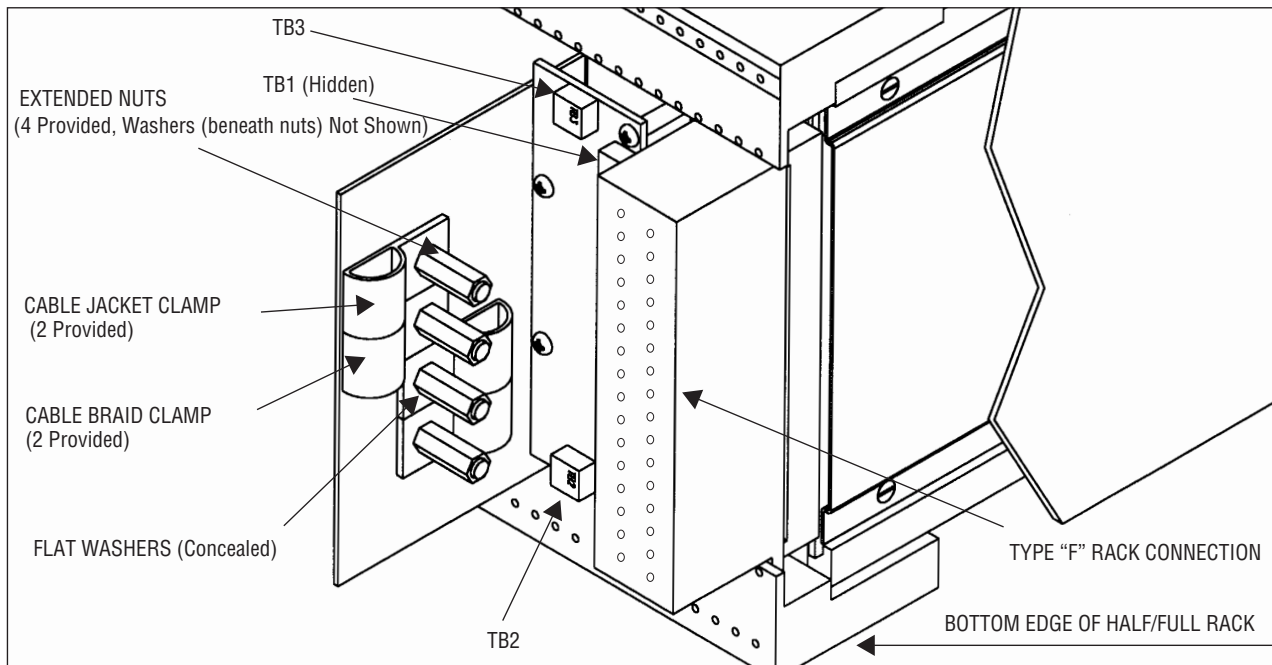

For ease of assembly, connect in order.

1. TB2 & TB3 (EMI filter board P/N 61-6898-2**).
 2. TB1 (EMI filter board, P/N 61-6898-2**).
- Type "F" rack connector (P/N 60-2478)

Note: **NOW OBSOLETE

NOTICE

When Fireeye products are combined with equipment manufactured by others and/or integrated into systems designed or manufactured by others, the Fireeye warranty, as stated in its General Terms and Conditions of Sale, pertains only to the Fireeye products and not to any other equipment or to the combined system or overall performance.

WARRANTIES

FIREYE guarantees for *one year from the date of installation or 18 months from date of manufacture* of its products to replace, or, at its option, to repair any product or part thereof (except lamps, electronic tubes and photocells) which is found defective in material or workmanship or which otherwise fails to conform to the description of the product on the face of its sales order. **THE FOREGOING IS IN LIEU OF ALL OTHER WARRANTIES AND FIREYE MAKES NO WARRANTY OF MERCHANTABILITY OR ANY OTHER WARRANTY, EXPRESS OR IMPLIED.** Except as specifically stated in these general terms and conditions of sale, remedies with respect to any product or part number manufactured or sold by Fireeye shall be limited exclusively to the right to replacement or repair as above provided. In no event shall Fireeye be liable for consequential or special damages of any nature that may arise in connection with such product or part.