



Instruction manual Series 854 XTG level gauge

Instruction manual series 854 XTG level gauge

September 2013
Part no. 4416.275
Revision 6



Enraf B.V.
P.O. Box 812
2600 AV Delft
The Netherlands

Honeywell Enraf

Tel.: +31 15 2701100, Fax: +31 15 2701111
E-mail: hfs-tac-support@honeywell.com
<http://www.honeywellenraf.com>

Copyright 1999 - 2013 Enraf B.V. All rights reserved.

Reproduction in any form without the prior consent of Enraf B.V. is not allowed. This manual is for information only. The contents, descriptions and specifications are subject to change without notice. Enraf B.V. accepts no responsibility for any errors that may appear in this manual.

The warranty terms and conditions applicable in the country of purchase in respect to Enraf B.V. products are available from your supplier. Please retain them with your proof of purchase.

Preface

This manual is intended for technicians involved with the commissioning and service of the Honeywell Enraf series 854 XTG level gauge.

A description preceding the technical procedures gives the technical information necessary to understand its functioning. It is recommended to read this description prior to performing any of the procedures.

For mechanical and electrical installation of the 854 XTG, refer to the Installation guide 854 XTG level gauge. This manual describes the commissioning, maintenance and trouble shooting of the basic 854 XTG level measurement. Other features such as: level alarm outputs, analog level output, temperature measurement, pressure measurement, etc. are describes in separate manuals. For an overview, refer to the list of related documents in Appendix E.

Legal aspects

The information in this manual is the copyright property of Enraf B.V., the Netherlands. Enraf B.V. disclaims any responsibility for personal injury or damage to equipment caused by:

- Deviation from any of the prescribed procedures;
- Execution of activities that are not prescribed;
- Neglect of the general safety precautions for handling tools, use of electricity and microwave radiation.

EC declaration of conformity

This instrument is in conformity with the protection requirements of EC Council Directive 89/336/EEC. The CE conformity marking fulfils the provisions of

EN 50081-2 Generic Emission Standard
EN 50082-2 Generic Immunity Standard
73/23 EEC Low Voltage Directive

when installed, maintained and applied according to requirements as specified in this manual.

Additional information

Please do not hesitate to contact Enraf or its representative if you require additional information.

Table of contents

Preface	3
1 Introduction	6
1.1 Principle of measurement	6
1.1.1 Level measurement	7
1.1.2 Interface between two products	7
1.1.3 Relative density	7
1.2 Optional functions	7
1.3 Remote monitoring	8
1.4 Approvals (ATEX / IECEx, FM)	8
2 Safety	9
2.1 Safety aspects of the 854 XTG level gauge	9
2.2 Personal safety	10
2.3 Safety conventions	10
3 Commissioning	11
3.1 Checks before starting the commissioning	11
3.2 Installation of measuring drum and displacer	11
3.2.1 Tools	11
3.2.2 Installation of measuring drum	12
3.2.3 Installation of displacer	12
3.2.4 Unlocking (locking) the motor block	13
3.3 Programming (configuring) the gauge	14
3.3.1 Introduction into configuring the instrument	14
3.3.2 Apply power to the 854 XTG	16
3.3.3 Selecting dimension and decimal separator	17
3.3.4 Tank and gauge data	18
3.3.5 Alarm settings	20
3.3.6 Ullage readout	21
3.3.7 Password protection	21
3.4 Level calibration	22
3.4.1 Standard level calibration	22
3.4.2 Level calibration with a tank top reference stop	22
3.4.3 Level calibration using the top of ball valve	23
3.4.4 Interface measurement	24
4 Operation	25
4.1 Repeatability test	25
4.2 Lock test	25
4.3 Freeze and block commands	25
4.4 Unlock	26
4.5 Interface measurement	26
4.6 Dip mode	27
4.7 Servo Auto Test	28
4.8 Verify level calibration	30
4.8.1 Verify level calibration against a tank top reference stop	30
4.8.2 Verify level calibration on top of ball valve	30
4.9 Data items and operational commands	31

5	Maintenance	32
5.1	Preventive maintenance	32
5.2	Instrument covers	33
5.3	Drum compartment	33
5.3.1	Detailed description	33
5.3.2	Removing the measuring drum	34
5.3.3	Replacing the drum bearings	35
5.4	The electronic compartment	36
5.4.1	Detailed description	36
5.4.2	Dismantling the electronic compartment	37
5.4.3	Replacing software	38
5.4.4	Initializing NOVRAM	38
5.5	Calibrating force transducer	39
5.6	Synchronizing the reference encoder	40
6	Trouble shooting	41
6.1	Problems with displacer movement	41
6.2	XPU error code (item EP)	42
6.3	SPU error code (item ES)	42
6.4	SPU status request (item QS)	43
Appendix A	Article and part numbers	44
Appendix B	Additional information on displacers	47
Appendix C	ASCII table	49
Appendix D	PCB layout	50
Appendix E	Related documents	51
	Index	52

1 Introduction

The Honeywell Enraf 854 XTG (Xmission Technology Gauge) measures the liquid level and can be programmed to measure two additional interface levels.

The 854 XTG has four programmable level alarms, and also provides diagnostic information. This information can be displayed by the Portable Enraf Terminal (PET) as well as on remote systems.

Optionally, the instrument can be provided with software for density measurement of the stored product.

To adapt the 854 XTG level gauge to the application, different types of displacers (different in sizes as well as materials) and measuring wires of different materials are available.

The 854 XTG can be supplied with an optional board (called: HCU board) to interface optional equipments as:

- Spot temperature element (Pt100 RTD)
- Average temperature element (VITO MTT/LT temperature probe, MRT element or MPT element)
- Water bottom probe (VITO water probe, VITO combi probe or external HART water probe)
- Pressure transmitters (for vapour pressure measurement, HIMS density measurement)
- Analog 4-20 mA level output

The above functions are separately available or in combinations as with the previous MPU, HPU, HSU and TPU option boards

1.1 Principle of measurement

Refer to figure 1.1.

The principle is based on detection of variations in the buoyancy of a displacer. The displacer is suspended from a strong, flexible measuring wire which is stored on a precisely grooved measuring drum. The shaft of the drum is connected to the stepper motor via a magnetic coupling.

The apparent weight of the displacer is measured by a force transducer. The actual output of the force transducer is compared with a desired value for the apparent weight of the displacer. If a discrepancy exists between measured and desired value, an advanced software control module adjusts the position of the stepper motor.

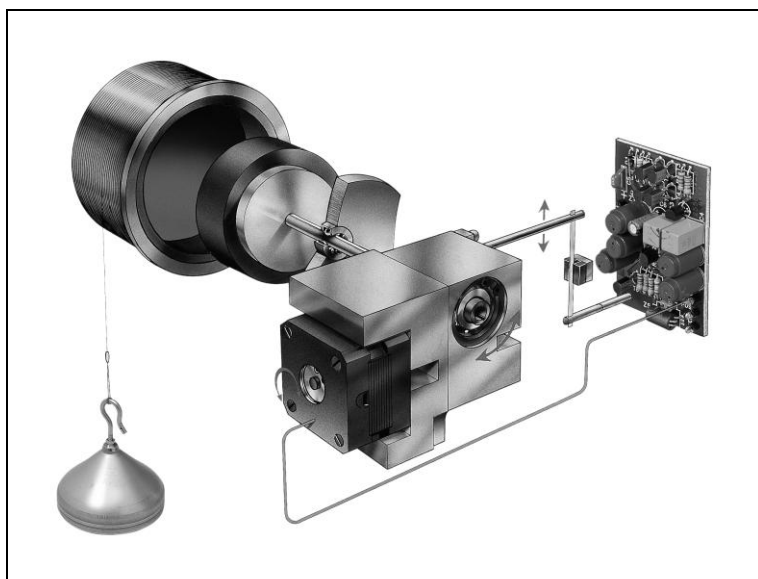

Figure 1.1 Principle of measurement

1.1.1 Level measurement

A level variation of product, in which the displacer is partially immersed, causes a change in buoyancy, which will be detected by the force transducer. The resulting difference between measured and desired value will cause a variation in the position of the stepper motor and consequently raise or lower the position of the displacer until the measured value equals the desired value.

To avoid oscillations, a certain hysteresis and integration time is software adjustable. This results in a stable and accurate averaged level measurement.

The stepper motor turns one revolution for every 10 mm of vertical movement of the displacer. One revolution is divided into 200 steps, therefore one step is equivalent to 0.05 mm. This resolution is direct consequence of the stepper motor principle. The correct functioning of the stepper motor is continuously checked. This is achieved by decoding the unique pattern of an encoder disk mounted on the motor shaft.

1.1.2 Interface between two products

Measurement of the interface between two products is achieved by sending an interface command to the gauge. This causes the stepper motor processor to move the displacer to a position where the apparent weight of the displacer matches a pre-programmed set point.

1.1.3 Relative density

To measure the relative density, the displacer is positioned at specific heights and the apparent weight of the displacer at each height is measured. Knowing the volume of the displacer, its weight in air, and the measured apparent weight, the relative density of the product at each position of the displacer can be calculated. The software for the density measurement is available as an option.

1.2 Optional functions

Optional functions can be added in the 854 XTG when using the optional HCU board to interface external equipment or generate an analog level output.

Alarm relays are optionally available on the SPU II board (Servo Processor Unit).

Density measurement is an optional module of the SPU software.

An XPU-2 board (instead of the previous XPU board) is required with the following options: with optional HCU board installed, RS-232C/RS-485 communication, connection for a 977 Tank Side Indicator and with the Servo Auto Test function.

The table on the next page gives an overview of all options and related manuals.

Option	Board	Refer to
Level alarm output relays (or digital outputs)	SPU II	Instruction manual SPU II Hard alarm output contacts
Density measurement	SPU II	Instruction manual 854 density option
Analog level output (4 - 20 mA)	HCU	Instruction manual Spot temperature and analog output options
Spot temperature measurement	HCU	Instruction manual Spot temperature and analog output options
Average temperature measurement via VITO temperature probe or MRT/MPT element	HCU	Instruction manual VITO
Pressure measurement for mass, density and/or vapour pressure measurement	HCU	Instruction manual HIMS/HTG
Water bottom measurement	HCU	Instruction manual VITO
Connection for 977 TSI Tank Side Indicator	XPU-2	Instruction manual 977 TSI Tank Side Indicator
RS-232C / RS-485 communication	XPU-2	Instruction manual XPU-2 option RS-232C / RS-485

1.3 Remote monitoring

Central monitoring of the 854 XTG is possible via tank inventory systems such as ENTIS+, CIU Plus or Entis Pro. Remote display can be achieved by using the 877 FDI field indicator, the 977 TSI tank side indicator or the 878 CPI panel indicator.

1.4 Approvals (ATEX / IECEx, FM)

The Honeywell Enraf 854 XTG level gauges are certified by official testing institutes as Factory Mutual and ATEX to be explosion proof (suitable for zone 0). The gauges are also approved and certified by Weights and Measures (W&M) or Custom and Excise authorities for legal use and custody transfer.

2 Safety

2.1 Safety aspects of the 854 XTG level gauge

Warning

*The 854 XTG is designed to measure the liquid level in storage tanks. The instrument is suitable for flammable liquids (refer to the explosion proof certification data below).
For other applications contact Honeywell Enraf.*

The housing of the 854 XTG is explosion proof:

- II 1/2 G Ex d IIB T6 Ga/Gb; II 1/2 G Ex d [ia Ga] IIB T6 Ga/Gb acc. to KEMA 02ATEX2193 X, certified by KEMA, Netherlands
- Ex d IIB T6 Ga/Gb; Ex d [ia Ga] IIB T6 Ga/Gb; acc. to IECEx KEM 10.0007X, certified by KEMA, Netherlands
- Class I, Division 1, Groups B, C & D, in acc. to ANSI/NFPA No. 70, certified by Factory Mutual Research USA (FM no.: 5Y2A9.AX).

The environmental conditions for the 854 XTG are:

ambient temperature	:	-40 to +85 °C (-40 to +185 °F)
operating pressure	:	max. 6 bar
relative humidity	:	0 - 100 %
ingress protection	:	IP65 (NEMA 4), suitable for outdoor installation
over voltage category	:	II
pollution degree	:	I

The drum compartment, which is in contact with the tank atmosphere, is separated from the electronic compartment. A magnet coupling transfers the measuring drum movement (and thus the displacer movement) to the electronic compartment.

The wiring for intrinsically safe options, such as temperature or pressure measurement, is fed via two separate cable entries.

The covers of the electronic compartment and terminal compartment are blocked by means of a setscrew, which prevents accidental opening.

Programming (configuration) of the 854 XTG can be done by the 847 PET (Portable Enraf Terminal), which is an intrinsically safe device and is connected to the 854 XTG via an infra-red coupling.

Caution

*The 854 XTG is an explosion proof instrument with intrinsically safe output/input circuits.
Modification to the instrument may only be carried out by trained personnel which is authorized by Enraf.
Failure to adhere to this will invalidate the approval certificate.*

*The safety approval can become invalid when the instrument housing is damaged.
Directly inform Honeywell Enraf in this case to verify if the instrument still can be used.*

2.2 Personal safety

Safe execution of the procedures in this manual requires technical experience in handling tools, and knowledge of safety regulations in handling electrical installation in hazardous environments.

The sequence of steps in a procedure may also be important from the point of view of personal safety and prevention of damage; it is therefore advised not to change the sequence of procedure steps or modify any procedure in any other way.

Warning

In hazardous areas it is compulsory to use personal protection and safety gear such as: hard hat, fire resistive overall, safety shoes, safety glasses and working gloves.

Avoid possible generation of static electricity. Use non-sparking tools and explosion proof testers. Do not open any of the instrument covers while power is still connected.

Never start working before the work permit is signed by all parties.

Pay attention to the kind of product in the tank. If any danger for health, wear a gas mask and take all necessary precautions.

2.3 Safety conventions

"**Warnings**", "**Cautions**", and "**Notes**" have been used throughout this manual to bring special matters to the immediate attention of the reader.

- A **Warning** concerns danger to the safety of the technician or user;
- A **Caution** draws attention to an action which may damage the equipment;
- A **Note** points out a statement deserving more emphasis than the general text, but does not deserve a "Warning" or a "Caution".

3 Commissioning

Caution

Keep screw thread from the compartment covers free from dirt.
Grease them lightly with anti seize grease before closing the instrument.
When closing, turn the covers counter-clockwise until the thread clicks into place, then turn clockwise.

3.1 Checks before starting the commissioning

Examine the mechanical and electrical installation after the 854 XTG is installed on the tank. Refer to the installation guide 854 XTG level gauge.

- Check the correct orientation of the gauge with respect to the tank.
- Check that the gauge is levelled within 2°.
- Check that the O-rings of the covers are properly installed.
- Check that the mains voltage on the label of the 854 XTG indicates the local mains supply.
- Check the connections in the terminal compartment of all electrical cabling.
- Check the ground connection of the 854 XTG to the tank.
- Check that non-used cable inlets are sealed with appropriate stopping plugs.
- Close carefully all covers (mind the O-rings) before any electrical power is applied.

3.2 Installation of measuring drum and displacer

3.2.1 Tools

It is recommended to use an 847 PET (Portable Enraf Terminal) to load the different parameters. A tool set for commissioning and maintenance is available from Enraf (refer to figure 3.1).

Item	Description
1	Allen key 3 mm
2	Allen key 4 mm
3	Allen key 5 mm
4	Allen key 8 mm
5	Drum bearing puller
6	Screwdriver for Allen key screws M4
7	Pipe wrench 27 mm
8	Tommy bar

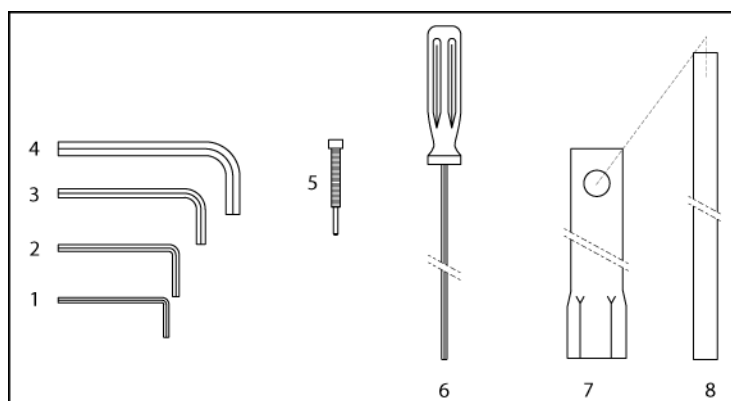

Figure 3.1 Tool set for 854 XTG (part no. A1894062)

3.2.2 Installation of measuring drum

- Remove the drum compartment cover (rear cover).
- Check whether the drum shaft is properly positioned in the drum.
- Attach the smallest of the four test weights (or another small weight) to the measuring wire, remove the rubber band securing the measuring wire and feed the wire and weight through the neck of the gauge (refer to figure 3.2).
- Insert the measuring drum onto its bearings.
- Check the axial free-play of the drum as follows:
Push the drum towards the magnet cap in such a way that the drum shaft meets the magnet cap. Release the drum. Bring the drum in a slight vibration. The drum and drum shaft should now move towards you with a axial movement of minimum 1 mm and maximum 2.5 mm.
- Note the engraved drum circumference value for later use. There are several numbers engraved on the measuring drum. The number you are looking for has a value of approximately 338 mm (for example: 338.028)

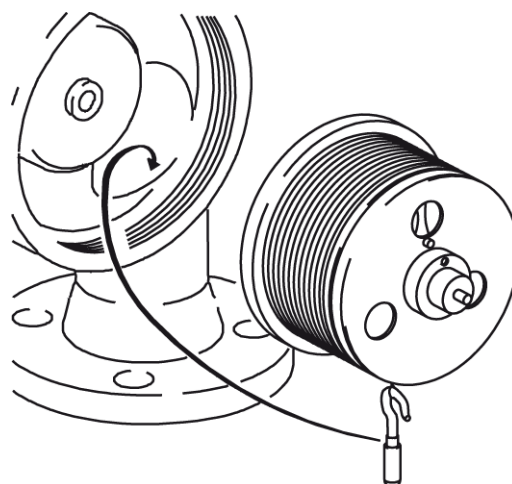

Figure 3.2 Installing the drum

3.2.3 Installation of displacer

- If a density displacer is used, note the engraved displacer weight and displacer volume for later use.
- Remove the test weight and attach the displacer to the wire through a mounting hatch.

Note:

If there is no mounting hatch available, the displacer can be installed by temporarily removing the gauge from the nozzle.

To provide electrical contact between the measuring wire and displacer, thus permitting the discharge of static electricity and preventing loss of the displacer, the displacer must be secured to the measuring wire.

- Take an extra piece of wire and fasten one end to the measuring wire, pass the other end through the hole in the end of the displacer hook. Secure this end several times around the hook (refer to figure 3.3).
- Close the drum compartment cover.

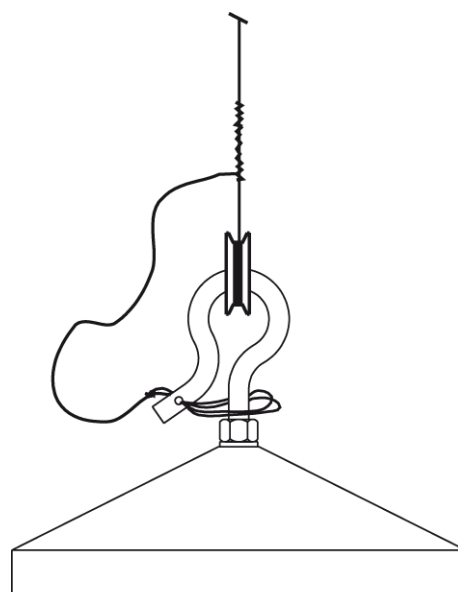

Figure 3.3 Mounting displacer

3.2.4 Unlocking (locking) the motor block

The motor block is locked during transport to protect the force transducer. After installing the measuring drum and displacer, the motor block locking latch must be unlocked.

Warning

Before opening the electronic compartment cover, switch off power.

- Open the electronic compartment cover (front cover). Mind the setscrew! (refer to figure 3.4).
- Locate the motor locking latch (refer to figure 3.5). Loosen (do not remove) the Allen key screw and slide the locking latch the opposite way. Use screwdriver for Allen key screws M4 (item 6 of the Enraf tool set).
- Fix the Allen key screw of the locking latch.
- Check the span wire. It should always be under tension while both ends are correctly positioned in the levers of the motor block and force transducer.
- Close the electronic compartment cover and lock it with the setscrew.

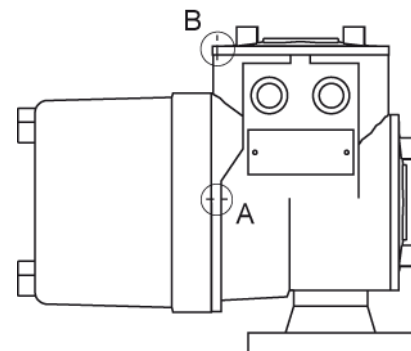

Figure 3.4 Setscrews locking the covers

Note:

Use the same procedure for locking the motor block if the 854 XTG needs to be removed.

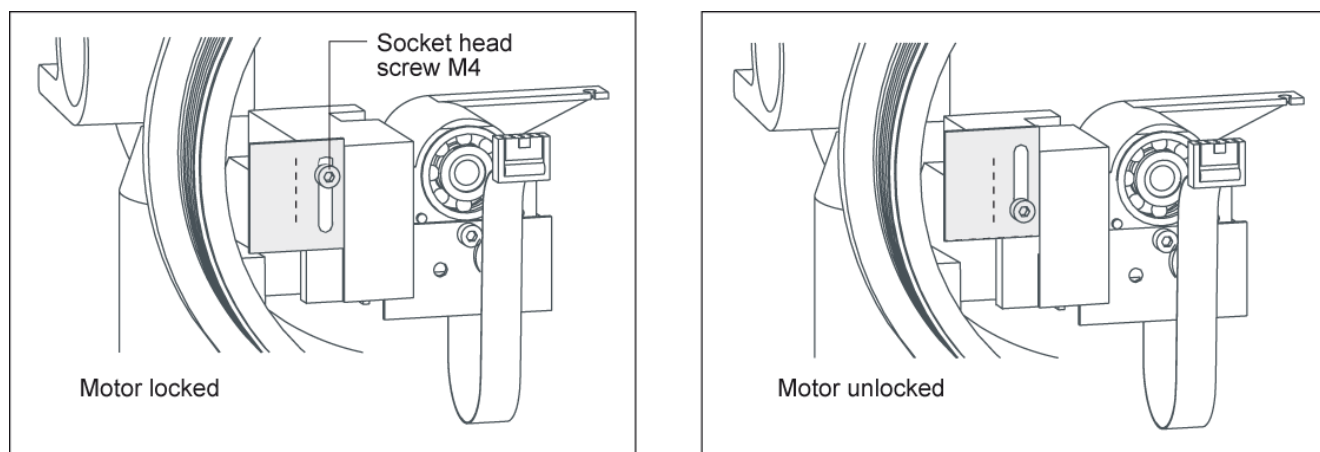

Figure 3.5 Motor block (un)locked

3.3 Programming (configuring) the gauge

3.3.1 Introduction into configuring the instrument

The 854 XTG is a field-configurable multi-processor instrument. The instrument can be totally programmed out in the field, or remotely, without opening the gauge.

It is recommended to use an 847 PET (Portable Enraf Terminal) to load the different parameters. It is coupled to the 854 XTG via an infra-red coupling. The 847 PET is intrinsically safe and waterproof (IP65) and consists of a full ASCII membrane keyboard and an LCD display (refer to figure 3.6). For more information, refer to the Instruction manual 847 Portable Enraf Terminal.

Alternatively, the Enraf service tool Engauge can be used to configure the instrument. The Engauge program runs on a PC under Windows®. It is recommended to use the service tool to make a log file of the instrument. A log file contains all important settings and the information is stored on the hard disk. For more information, refer to the Instruction manual Engauge service tool.



Figure 3.6 Programming the 854 XTG by using the 847 Portable Enraf terminal

The item concept

All parameters, settings, etc, are accessible via so-called items. These items all have unique 2-letter abbreviations which allow easy access and programming. In this manual, items are printed **bold**. There are three different type of items:

Type of item	Description
Commands	These will force the gauge to execute a special task or function. For example: EX (exit). After the EX command the instrument start initialising and modified NOVRAM settings become active.
Data requests	Items for request of setup or measuring data from the gauge. For example: JS (jumper setting). Item JS returns the jumper setting on the XPU(-2) board. Some of the data items are read-only.
NOVRAM settings	All parameters which can be programmed and should not be lost after power break down, are stored in NOVRAM. The NOVRAM is a non-volatile RAM memory which does not require battery back up.

Data stored in NOVRAM can be protected by a password and by the Weights & Measures (W&M) jumper on the XPU(-2) board (refer to figure 3.6).

Protection levels are provided for all NOVRAM items, depending on the importance of an item. Protection level 1 is protected by password 1 (**W1**) and protection level 2 is protected by password 2 (**W2**). If the NOVRAM is protected by the W&M jumper J(A)3 level 2 NOVRAM items cannot be changed without opening the gauge, thereby breaking off the sealing. Most data requests and commands are not password protected.

Protection level 1

Access to items which are not directly measurement related, such as high level alarm (**HA**), tank identifier (**TI**), etc. is protected by password 1 (**W1**). It is possible to modify these data only after entering the correct level 1 password W1=XXXXXX, where XXXXXX is the level 1 password. Password **W1** itself can be read protected by means of jumper J(A)1 on the XPU(-2) board.

Protection level 2

ALL NOVRAM items which affect the (remote) level reading, such as reference level (**RL**), transmission address (**TA**), etc. are protected by password 2 (**W2**). It is possible to modify these data only after entering the correct level 2 password W2=XXXXXX, where XXXXXX is the level 2 password. Additional measurement related items, such as temperature items, can also be protected by password 2.

Password **W2** itself can be read protected by means of jumper J(A)2 on the XPU(-2) board. In protection level 2, the items which reside under protection level 1 can also be modified.

W&M protection

Items under protection level 2 can also be protected by jumper J(A)3 on the XPU(-2) board. If this jumper is placed in position 1, the write access is completely disabled. Also issuing the correct level 2 password will not work.

The table below gives an overview of the XPU(-2) jumper functions (refer also to figure 3.7).

Jumper (XPU / XPU-2)	Function	Position "0"	Position "1"
JA1 / J1	read password 1	not protected	protected
JA2 / J2	read password 2	not protected	protected
JA3 / J3	W&M protection	not protected	protected
JA4	NOVRAM initialising	active	not active
JA5 - JA7 / J4 - J6	spare		

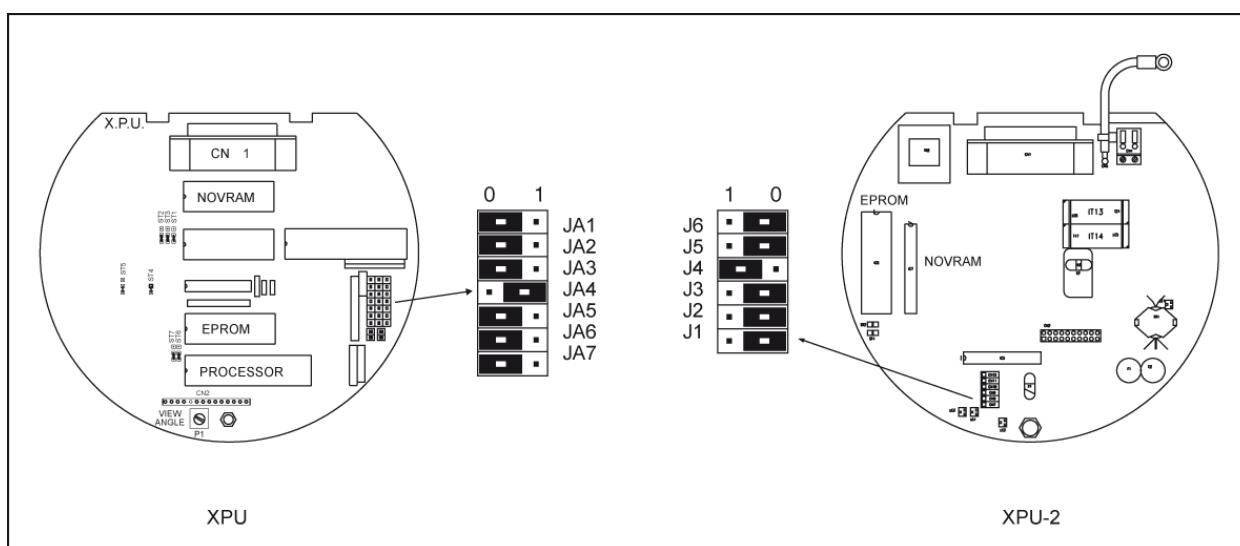

Figure 3.7 Jumpers on XPU and XPU-2 board

How to program?

When the 847 PET is plugged into the 854 XTG IR connector and the instrument is powered, the PET can be switched on. By operating the keyboard, items can be requested and settings can be changed.

For example:

Item (+ setting) (typing in on PET keyboard)		Description
RL	<enter>	Request for the current value of item RL (reference level). The reply on the PET display will be: RL+026.0000 This means: the reference level is: 26 metres.
W2=ENRAF2	<enter>	Enter protection level 2 (default level 2 password is: ENRAF2).
RL=+012.3400	<enter>	Give the required setting for the reference level (here, as an example: 12.34 metres).
EX	<enter>	Exit protection level 2. The 854 XTG will now initialise and the new entered value of the reference level will become active after the re-start.

Recommended programming sequence

The 854 XTG is already pre-programmed at the factory. However, several parameters, application depended, must be programmed at commissioning.

- Step 1** Start with programming / checking of the format depended items (refer to section 3.3.3)
- Step 2** Proceed with programming / checking of the items for the standard level measurement without optional functions (refer to sections 3.3.4 to 3.3.7).
- Step 3** Check the identification code on the label of your 854 XTG with the Identification code sheet, whether the gauge is equipped with one or more optional functions, and program the items for that options (refer to the appropriate option manuals).

3.3.2 Apply power to the 854 XTG

To program the gauge, power must be switched on. That should be done in this stage.

Note:

After the initialisation of the gauge, the displacer is moving down, because the default level setting is at 26 metres.

If the displacer movement is unwanted in this stage, issue the **FR** command by the PET. This action freezes the displacer position. This command must be repeated after each **EX** (exit) or **RS** (reset) command.

The freeze command can be cancelled by the **UN** (unlock) command.

3.3.3 Selecting dimension and decimal separator

When one of the dimension items are changed, all items with related formats have to be changed and the values must be converted to the new dimension. The same applies for the decimal separator.

Note:

When the 854 XTG is equipped with an XPU-2 board (can be recognised by requesting the software version item **SV** reads: XPU ... Hx.x), then all dimension depended items will be automatically changed and the values will be automatically converted.

Item	Name	Description
W2=	Protection level 2	Enter protection level 2 (default password: ENRAF2)
LD=	Level dimension	Selects and converts the level dimension. This item contains one character, which can be: M : metres; format: sign X X X separator X X X X F : feet; format: sign X X X X separator X X X I : inches; format: sign X X X X X separator X X P : fractions; format: sign X X ' X X " X X
DP=	Decimal separator	The item DP (decimal separator) can be: . : point or , : comma
.. =	<i>format depended items</i>	Not required with XPU-2 board. Program all level dimension and/or decimal separator depended items to the new dimension and/or separator. Refer to the table below for an overview of these items.
EX	Exit	Exit protection level

Items from which the format depends on the level dimension <i>and</i> decimal separator				Additional items from which the format depends on the decimal separator	
AH	HL	LP *)	MP *)	28 *)	M1 *)
AM *)	IL *)	LS *)	MZ	29 *)	M2 *)
AN *)	L2	MG *)	RL	DL *)	M3 *)
DB	L3	MH	RP *)	DU *)	O1 *)
DH	LA	MI *)	TT	H1 *)	O2 *)
DZ	LL	MK *)	UR	H2 *)	O3 *)
HA	LM *)	ML		H3 *)	PH *)
HH	LN *)	MO *)		HD *)	RO *)

*) The presence of these items depends on the installed option board

Standard floating point format

Some items are expressed in a floating point format. The floating point format is a fixed format;

- Standard floating point format: sign point M M M M M M M M E sign P P
 where: M = Mantissa
 P = Exponent

3.3.4 Tank and gauge data

Refer to figure 3.8 for the tank related data. The distances in figure 3.7 are all related to the tank zero point (dipping datum point).

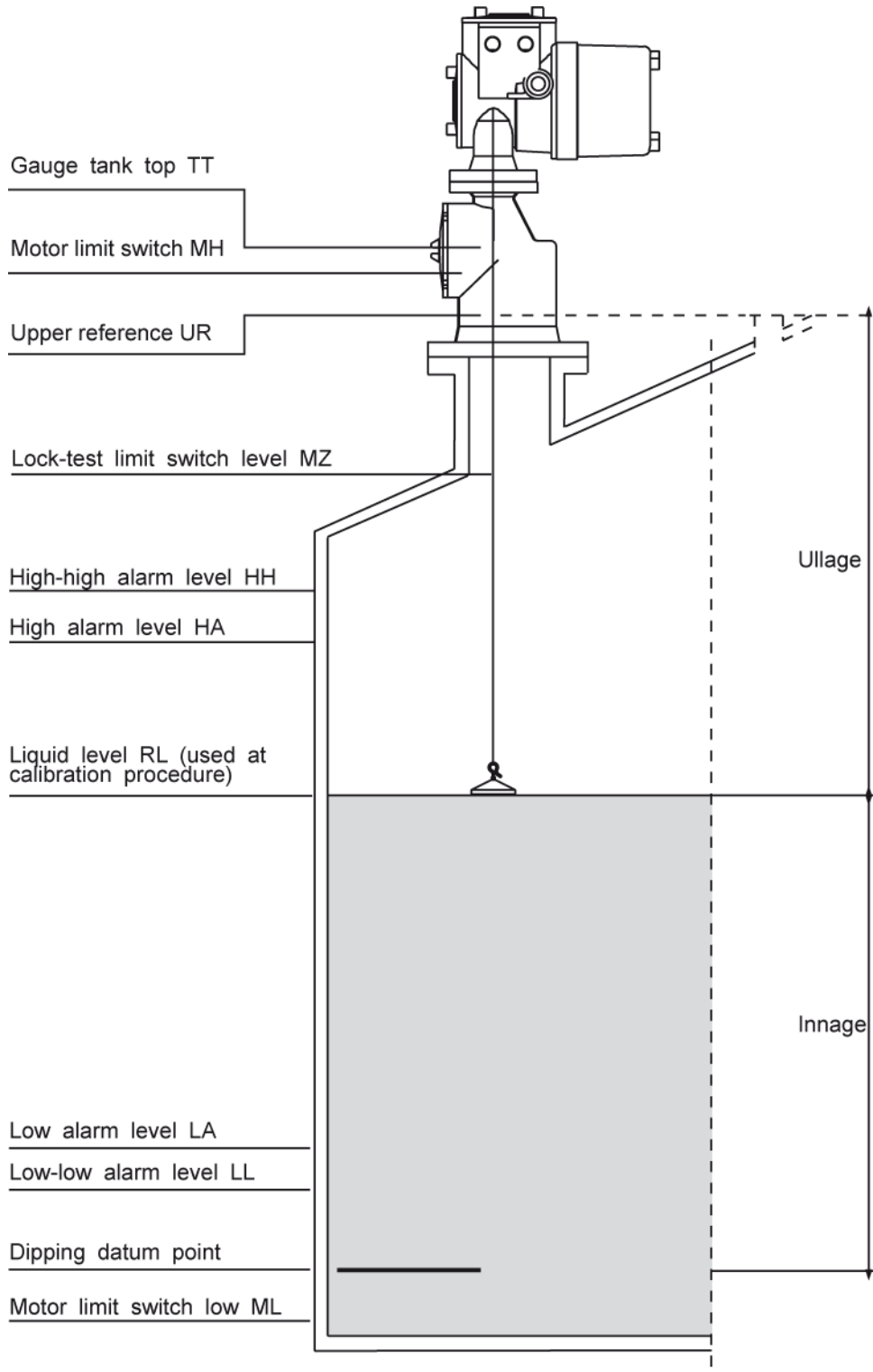

Figure 3.8 Tank related level items

Item	Name	Description								
W2=	Protection level 2	Enter protection level 2 (default password: ENRAF2)								
TT=	Tank top	Format according to item LD . The tank top level must be set for correct wire weight compensation. The value you enter now, is overwritten when the level calibration with displacer stop is used.								
MH=	Motor limit switch high	Format according to item LD . This is the highest allowed position for the displacer during normal operation.								
MZ=	Lock test limit switch level	Format according to item LD . Item MZ sets the highest displacer position during a lock test.								
ML=	Motor limit switch low	Format according to item LD . This is the lowest allowed position for the displacer during normal operation.								
DC	Drum circumference	Standard floating point format; units: metres. Check whether the pre-programmed drum circumference is in accordance with the engraved value of the installed measuring drum. If that is not correct, enter the engraved drum circumference.								
DW	Displacer weight	Standard floating point format; unit: grams. The standard displacers have a weight of 223 g. If a density displacer is used, check whether the engraved weight is programmed correctly in this item. If not, then enter the engraved displacer weight.								
DA	Displacer area	Standard floating point format; units: cm ² . Check whether the pre-programmed displacer area is in accordance with the used type of displacer. Refer to Appendix B for information on the displacer area values. If not correct, program the correct displacer area.								
S1	Set point	Standard floating point format; units: grams. With the standard displacers, the interface 1 set point (level surface) is set to 208 g. If a density displacer is used, program S1 as: (DW - 15).								
TA=	Transmission address	Two digits. The transmission address identifies the gauge on the Enraf 2-wire field bus. Each gauge must have a unique address, and hence TA must be programmed differently. When connected to an 858 CIU, please note that the 858 CIU has three highways, containing the following transmission addresses:								
		<table border="1"> <thead> <tr> <th>CIU highway</th> <th>Transmission address (TA)</th> </tr> </thead> <tbody> <tr> <td>TL 1</td> <td>00 – 29</td> </tr> <tr> <td>TL 2</td> <td>30 – 59</td> </tr> <tr> <td>TL 3</td> <td>60 – 99</td> </tr> </tbody> </table>	CIU highway	Transmission address (TA)	TL 1	00 – 29	TL 2	30 – 59	TL 3	60 – 99
CIU highway	Transmission address (TA)									
TL 1	00 – 29									
TL 2	30 – 59									
TL 3	60 – 99									
TI=	Tank identifier	Six characters. Used as a label; the tank name can be programmed in the tank identifier item (spaces are not allowed!).								
TS=	Transmission speed	Four digits; either 1200 (default) or 2400. Units: baud								
GT=	Gauge type	One character. Represents the gauge type. For the 854 XTG, GT=B.								
EX	Exit	Exit protection level 2. The gauge will now initialize and after start-up, the modified settings become active.								

Example:

On tank 102 is the nozzle height 21.350 m and the nozzle length is 300 mm. The displacer may not enter the nozzle. The maximum operating level is 19.1 metres. Because of sludge, the motor limit switch low must be set on 300 mm. A standard 90 mm carbon Teflon displacer is used and the drum circumference is 338.025 mm. The gauge is connected to CIU highway TL1 and the address is chosen as 02. The level dimension is metres.

Item (+setting)		Description
W2=ENRAF2	<enter>	Enter protection level 2 (ENRAF2 is the default level 2 password).
TT=+021.3500	<enter>	Tank top is 21.35 metres.
MH=+021.0500	<enter>	Motor limit switch high set at 21.35 - 0.3 = 21.05 metres.
ML=+020.0000	<enter>	Lock test limit switch level is set between maximum operating level and MH .
ML=+000.3000	<enter>	Motor limit switch low set at 0.3 metres.
DC	<enter>	Check whether the drum circumference is correct; if not, change it.
DW	<enter>	Check whether the displacer weight is correct; if not, change it.
DA	<enter>	Check whether the displacer area is set correct; if not, change it.
S1	<enter>	Check whether the set point 1 is set correct; if not, change it.
TA=02	<enter>	The transmission address becomes: 02.
TI=TK-102	<enter>	Tank identifier programmed as TK-102.
TS	<enter>	Check whether the transmission speed is correct; if not, change it.
GT	<enter>	Check whether the gauge type is set correct; if not, change it.
EX	<enter>	Exit protection level.

3.3.5 Alarm settings

Refer to figure 3.8. The high level alarm (**HA**) and low level alarm (**LA**) conditions are transmitted to the host via the 2-wire Enraf field bus (or optional RS-channel).

Item	Name	Description
W2=	Protection level 2	Enter protection level 2 (default level 2 password: ENRAF2).
AH=	Level alarm hysteresis	Format according to item LD . Sets alarm hysteresis.
HA=	High level alarm	Format according to item LD . High level alarm set point.
HH=	High high level alarm	Format according to item LD . High high level alarm set point.
LA=	Low level alarm	Format according to item LD . Low level alarm set point.
LL=	Low low level alarm	Format according to item LD . Low low level alarm set point.
EX	Exit	Exit protection level.

3.3.6 Ullage readout

When an ullage measurement is required, the two items shown below must be changed.

The ullage, or outage, measurement is referred to a 'zero' point at the tank top (upper reference point).
The level, or innage, measurement is referred to a 'zero' point at the tank bottom (datum plate).
Refer to figure 3.8.

Note:

The high and low level alarms are "innage" alarms.

*Hence a **high alarm** condition occurs when there is a **low ullage** value and visa verse.*

Item	Name	Description
W2=	Protection level 2	Enter protection level 2 (default password: ENRAF2)
UR=	Upper reference	Format according to item LD . The distance UR represents the distance from the □innage□ zero point (datum plate) to the upper reference point at a dip hatch (or other point at the tank top).
DE=	Level type	One character; either C, I or U. C : for hydrostatic deformation compensated innage measurement I : for innage measurement (default) U : for ullage measurement
EX	Exit	Exit protection level.

3.3.7 Password protection

Item	Name	Description
W2=	Protection level 2	Enter protection level 2 (default password: ENRAF2)
W1=	Password 1	Six characters, default password is: ENRAF1. You can define your own level 1 password by entering six characters. Password 1 is read protected if strap J(A)1 on the XPU(-2) board is in position '1'.
W2=	Password 2	Six characters, default password is: ENRAF2. You can define your own level 2 password by entering six characters. Password 2 is read protected if strap J(A)2 on the XPU(-2) board is in position '1'.
EX	Exit	Exit protection level.

3.4 Level calibration

3.4.1 Standard level calibration

Make sure the displacer is at the liquid surface. Perform a repeatability test to ensure the displacer is on the product surface (refer to section 4.1).

Determine the product level by manual dipping. It is essential that the level is as stable as possible.

Note:

Make two or three manual dips and compare each reading to ensure the manual dip value is correct.

Item	Name	Description
W2=	Protection level 2	Enter the protection level 2 password
RL=	Reference level	Format according to item LD . Enter in this item the manual level.
AR	Accept reference	By giving this command, the level value entered in item RL , is accepted as product level.
EX	Exit	Exit protection level.

3.4.2 Level calibration with a tank top reference stop

A tank top reference stop is a mechanical device that can hold the displacer at a reproducible position when the displacer is pulled up. This device is placed above the motor limit switch high position. An Enraf tank adapter can be provided with such a facility.

- 1) Follow the procedure as described in section 3.4.1
- 2) Determine the tank top position; proceed as follows:

Item	Name	Description
W2=	Protection level 2	Enter the protection level 2 password.
CA	Calibrate	With this command the displacer is pulled up until it is halted against the tank top reference. Wait until the displacer is settled.
CQ	Compensated servo innage	Format according to item LD . Read the compensated servo innage value at the tank top reference stop.
TT=	Tank top	Format according to item LD . Program the tank top reference stop value from item CQ into item TT .
EX	Exit	Exit protection level.

For verification of the level calibration, refer to section 4.7.1.

3.4.3 Level calibration using the top of ball valve

If level dipping is not possible, the 854 XTG can be calibrated using the top of a ball valve as reference point. Proceed as follows:

Item	Name	Description
W2=	Protection level 2	Enter protection level 2 password
CA	Calibrate	The displacer will be raised until it stops against the flange of the level gauge.
		<i>If a 45 mm displacer is used, stop immediately the Calibrate command as soon as the displacer is above the ball valve, followed by an FR (freeze) command.</i>
		<ul style="list-style-type: none"> ➤ Make sure the displacer is positioned above the ball valve. Close the ball valve.
		<ul style="list-style-type: none"> ➤ Calculate the immersion depth of the displacer at the product interface (for a 90 mm displacer use 3 mm; for a 45 mm displacer use 12 mm).
UN	Unlock	Unlock the gauge and wait the displacer reaches the top of the ball valve.
		<ul style="list-style-type: none"> ➤ Calculate the immersion depth of the displacer at the product interface (for a 90 mm displacer use 3 mm; for a 45 mm displacer use 12 mm).
RL=	Reference level	Format according to item LD . Enter the position of the top of the ball valve with respect to the tank zero adding the immersion depth of the displacer at the product level.
AR	Accept reference	By giving this command, the level value entered in item RL , is accepted as level value.
EX	Exit	Exit protection level.
CA	Calibrate	The displacer will now raise from the ball valve. Let it stop against the flange or give a FR (freeze) command.
		<ul style="list-style-type: none"> ➤ Open the ball valve.
UN	Unlock	Unlock the gauge. The displacer will now move down till it reaches the level.

For verification of the level calibration, refer to section 4.7.2.

3.4.4 Interface measurement

Interface 3 (**I3**) is used as product / water interface measurement (with interface 2 (**I2**) another interface can be measured). The set point **S3** has to be set to such a value that half of the displacer volume is immersed in the water and the other half of the displacer volume is immersed in the product.

That can be calculated as follows (refer to figure 3.9 and to Appendix B for detailed displacer information):

$$S3 = DW - (\frac{1}{2}DV \times \rho_{product} + \frac{1}{2}DV \times \rho_{water}) \text{ [g]}$$

where:

- S3** : set point I3 measurement [g]
- DW** : displacer weight [g]
- DV** : displacer volume [cm³]
- $\rho_{product}$: density of the product [g/cm³]
- ρ_{water} : density of water [g/cm³]

Example:

- Displacer #0815.343 : ø45 mm
- Displacer weight (**DW**) : 223 g
- Displacer volume (**DV**) : 105 cm³
- Volume lower conical part : 3.2 cm³
- Height lower conical part : 6 mm
- Density product : 0.9 g/cm³

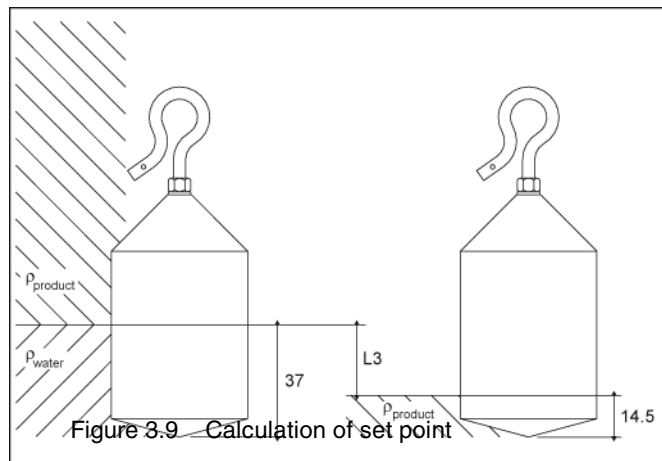

Figure 3.9 Calculation of set point

$$S3 = 223 - (52.5 \times 0.9 + 52.5 \times 1) = 123.25 \text{ [g]}$$

A level offset must be given as the displacer is now immersed for half of the volume in water. On product level the displacer is immersed less. The difference between both immersion depths must be given in item **L3**.

Example:

- 1) Immersion depth on product level surface:
 - displaced volume : $(DW - S1) / \rho_{product} = 15 / 0.9 = 16.67 \text{ cm}^3$
 - volume in cylindrical part : $16.67 - 3.2 = 13.47 \text{ cm}^3$
 - immersion of cylindrical part : $13.47 / \pi r^2 = 13.47 / (\pi \times 2.25^2) = 0.85 \text{ cm} = 8.5 \text{ mm}$
 - immersion depth on product : $8.5 + 6 = 14.5 \text{ mm}$
- 2) Separation line product / water:
 - water volume in cylindrical part : $\frac{1}{2}DV - 3.2 = 52.5 - 3.2 = 49.3 \text{ cm}^3$
 - water height in cylindrical part : $49.3 / \pi r^2 = 49.3 / (\pi \times 2.25^2) = 3.1 \text{ cm} = 31 \text{ mm}$
 - separation line product / water : $31 + 6 = 37 \text{ mm}$ (from lower end of displacer)

Hence, level offset **L3** becomes : $37 - 14.5 = 22.5 \text{ [mm]}$

Item	Name	Description
W2=	Protection level 2	Enter protection level 2 password
S3=	Set point I3	Standard floating point format; units: grams. Set point for the product / water interface measurement.
L3=	Level offset I3	Format according to item LD . Level offset between interface 1 immersion depth (where the gauge is calibrated) and the product / water interface immersion depth.
EX	Exit	Exit protection level

4 Operation

4.1 Repeatability test

With the repeatability test the displacer is raised for approximately 75 mm (3") and then returns to the product surface.

Item	Name	Description
TG	Test gauge	Performs a repeatability test on the level measurement.

The level reading before and after the test may not differ more than 1 mm ($1/16$ ").

4.2 Lock test

The lock test command brings the displacer to the position, programmed in item **MZ** (lock test limit switch level).

Item	Name	Description
LT	Lock test	The Lock test raises the displacer to the programmed MZ position. Then the gauge goes into block mode (BL). If MZ is set higher than MH (motor limit switch high) the displacer stops at the programmed MH position.

The displacer will remain in one of these two positions until an unlock command (**UN**) is given.

4.3 Freeze and block commands

Both the freeze (**FR**) and block (**BL**) commands stops the displacer at the current position.

With the freeze command, the displacer remains in its position even when the level reaches the displacer position. Hence, the level can not be followed and the high and high high level alarms can not be generated.

The block command stops the displacer, and depending on how the block mode (item **BM**) is set, the displacer will move up with an increasing level, or the block is cancelled when the level reaches the displacer position.

Item	Name	Description
FR	Freeze	The displacer remains in its position even when the level reaches the displacer position.
BL	Block	The displacer stops at its present position, and depending on the status of item BM , the displacer will move up with an increasing level, or the block is cancelled when the level reaches the displacer position.

The displacer will remain in its position until an unlock command (**UN**) is given.

Item **BM** has to be set (checked) at commissioning (or at a later stage):

Item	Name	Description
W1=	Protection level 1	Enter protection level 1 password
BM=	Block mode	One character; either C (default) or N. C : Continuous; when the level reaches the displacer position, the displacer will follow the increasing level. N : Non-continuous; the block mode is cancelled when the level reaches the displacer position.
EX	Exit	Exit protection level

4.4 Unlock

The unlock command (**UN**) cancels any of the following operational commands:

- | | | | |
|----------------|-------------|--------------|-------------|
| • Freeze | (FR) | • Block | (BL) |
| • Balance test | (BT) | • Lock test | (LT) |
| • Go up | (GU) | • Calibrate | (CA) |
| • Go down | (GD) | • Test gauge | (TG) |

Item	Name	Description
UN	Unlock	The unlock command cancels the operational commands: BL, BT, CA, FR, GD, GU, LT and TG .

4.5 Interface measurement

The 854 XTG can measure three different interfaces. Interface 1 (**I1**) is normally used to measure the product level. Interface 3 (**I3**) can be used to measure the product / water interface. Interface 2 (**I2**) is a setting for a special measurement (i.e. interface between two product layers).

Item	Name	Description
I1	Interface 1	Interface 1 measurement (based on set point 1); normally used for product measurement.
I2	Interface 2	Interface 2 measurement (based on set point 2); setting for special measurement.
I3	Interface 3	Interface 3 measurement (based on set point 3); normally used for product / water measurement.

The default setting is on interface 1 (**I1**). If one of the other two interface measurements is selected, the gauge will remain on that interface measurement till the default measurement (**I1**) is selected.

4.6 Dip mode

When the gauge is in dip mode the displacer will be set at some distance (**DH**) above interface 1 (product surface). After a certain time (**DT**) a single product measurement is executed. After the interface has been measured, the displacer will be raised over the dip height (**DH**).

The level transmitted to the host will be the dipped level and not the actual displacer position.

Item	Name	Description
DM	Dip mode	Activates the dip mode. In dip mode the displacer is positioned at distance DH above the product and after a time interval DT , the product is dipped.

The dip mode is cancelled when one of the interface measurements is selected.

For the dip mode, items **DH** and **DT** have to be set (checked) during commissioning (or at a later stage):

Item	Name	Description
W1=	Protection level 1	Enter protection level 1 password
DH=	Dip height	Format according to item LD . In dip mode, the displacer is raised above the product over the dip height distance DH .
DT=	Dip time interval	Standard floating point format; unit: seconds. In dip mode, the interval time for the dip is specified in the dip time interval DT . Minimum value: 1 sec. maximum value: 32767 sec.
EX	Exit	Exit protection level.

4.7 Servo Auto Test

The Servo Auto Test (SAT hereafter) is an automatic safety related function meant to reduce the small risk of tank overflow caused by a failing servo gauge. Immediately after the gauge detects that tank loading has finished a SAT is executed to rule out (or detect) that the gauge is unable to measure the product level due to some failure (e.g. blockage of displacer). The gauge will raise the displacer over a programmable distance (item **SH**). If the movement is not completed within the expected time, the gauge will retry. If this second try also fails, a third and final attempt is made. Should even the third try fail, the gauge will update the display by removing the measurement unit and display the fill mode. After that the gauge will go into General Fail mode and item **ES** is set to the value 607 (SAT failed for three consecutive attempts). From this moment on the gauge will respond only to status requests and the reset command (item **RS**).

The SAT will not only be executed immediately after tank loading has apparently stopped, but also at regular intervals configurable through item **SI**.

The SAT can also be performed manually by entering the command **PQ**.

The default behaviour of the SAT can be influenced by means of a number of configuration items.

Item	Name	Description
SE	SAT enable	When set to 'E' (enabled) a SAT will be started roughly 1 minute after tank loading has apparently stopped. Furthermore SATs will be executed at regular intervals. When set to 'D' (disabled) there will be no automatic SAT at all. The operator can however start a SAT by manually entering the PQ command.
SH		SAT raise height With this item the operator can configure the height over which the displacer is raised during the SAT.
SI	SAT interval time	With this item the operator can configure the time between two consecutive SATs.
SY	SAT invalidate display and level	<p>When set to 'N' (NO), during SAT</p> <ul style="list-style-type: none"> - An asterisk (*) will be shown on the same position where normally the arrow up/down symbols are displayed. <p>When set to 'Y' (YES), during SAT</p> <ul style="list-style-type: none"> - An asterisk (*) will be shown on the same position where normally the arrow up/down symbols are displayed. - Both the measurement unit and the measurement type will be set to exclamation marks. - All level related GPU records will be invalidated. - Items like QS, LQ, UQ and CQ are unaffected.

The behaviour of the function responsible for the level movement detection part of the SAT can be influenced by means of 2 configuration parameters.

Item	Name	Description
XI	SAT level movement sample interval	The movement detector samples the level in the tank at regular intervals. The operator can configure the time between two consecutive samples by means of this item.
XT	SAT level movement trip distance	If the absolute level difference between two samples exceeds the trip distance given in this item, then the tank is apparently being loaded or unloaded.

Simple audit trail functionality is implemented by recording several SAT related parameters.

Item	Name	Description
PE	SAT last fail level	Level at which a SAT last failed.
PL	SAT last level	Level at which the most recent SAT was performed.
PX	SAT minimum level	Lowest level at which a SAT has been performed since NOVRAM initialization.
PY	SAT maximum level	Highest level at which a SAT has been performed since NOVRAM initialization.
PZ	SAT max retries	highest number of retries observed during a SAT since NOVRAM initialization.
SN	SAT total number	Total number of SATs performed since NOVRAM initialization.
SZ	Sat time since last test	Number of minutes elapsed since the most recent SAT successfully completed.

For a more elaborate description of the items listed above, please refer to the separate item document.

4.8 Verify level calibration

4.8.1 Verify level calibration against a tank top reference stop

When a tank adapter with a tank top reference stop is installed, the level calibration of the 854 XTG can be checked. Proceed as follows:

Item	Name	Description
CA	Calibrate	With this command the displacer is pulled up until it is halted against the tank top reference. Wait until the displacer is settled.
CQ	Compensated servo innage	Read the displacer position against the tank top reference.
TT	Tank top	Request for the tank top value, which was established during level calibration. The level reading obtained from item CQ should not differ more than ± 3 mm ($\pm 1/8$ ") with the value in item TT .
UN	Unlock	Give an unlock command to cancel the calibrate command.

If the tank top value and the gauge reading (item **CQ**) differs more than the specified value, the calibration procedure as described in section 3.4.2 should be repeated.

4.8.2 Verify level calibration on top of ball valve

If the top of the ball valve is used as reference point, the level calibration of the 854 XTG can be verified. Proceed as follows:

Item	Name	Description
CA	Calibrate	<p>The displacer will be raised until it stops against the flange of the level gauge.</p> <div style="border: 1px solid black; padding: 5px; margin: 10px 0;"> <p><i>If a 45 mm displacer is used, stop immediately the Calibrate command as soon as the displacer is above the ball valve, followed by an FR (freeze) command.</i></p> </div> <p>➤ Make sure the displacer is positioned above the ball valve. Close the ball valve.</p>
UN	Unlock	Unlock the gauge and wait the displacer reaches the top of the ball valve.
CQ	Compensated servo innage	Read the displacer position on top of the ball valve.
RL	Reference level	Request for the reference level value, which was established during calibration. The level reading obtained from item CQ should not differ more than ± 2 mm ($\pm 1/16$ ") with the value in item RL .
CA	Calibrate	<p>The displacer will now raise from the ball valve. Let it stop against the flange or give a FR (freeze) command.</p> <p>➤ Open the ball valve.</p>
UN	Unlock	Give an unlock command to cancel the calibrate command.

If the reference level value and the gauge reading (item **CQ**) differs more than the specified value, the calibration procedure as described in section 3.4.3 should be repeated.

4.9 Data items and operational commands

Below a summary of data items, error codes and operational commands.

Data items:

Item	Description
CQ LQ UQ QS	Measured data Compensated servo innage*) Servo innage Servo ullage Servo status request
BF BU BV BW FQ WQ	Control data Average measured frequency Maximum unbalanced weight Minimum unbalanced weight Average measured weight Frequency request Weight request
EP ES	Error codes Error XPU request Error SPU request

*) Compensated for hydrostatic tank deformation (item **HF**, **HL**).

Operational commands:

Item	Description	Item	Description
BL	Block	I2	Interface 2
BT	Balance test	I3	Interface 3
CA	Calibrate	LT	Lock test
DM	Dip mode	MF	Measure frequency
FR	Freeze	TG	Test gauge
I1	Interface 1	UN	Unlock

5 Maintenance

5.1 Preventive maintenance

Whether maintenance is needed can be checked with the following tests:

Repeatability test (refer to section 4.1).

If repeatability deteriorates (more than 1 mm) the drum bearings should be replaced (refer to section 5.3.3).

Balance test

The measuring drum unbalance can be measured by the following procedure:

Item	Name	Description
LT	Lock test	Raise the displacer for approximately 0.6 m (2 ft) above the product level.
FR	Freeze	Stop the lock test and wait till the displacer is in a complete rest (one or two minutes).
BT	Balance test	With this command the balance of the measuring drum is checked. This measurement takes approximately 5 minutes. When the balance test is ready, the status on the PET display changes from BT into FR.
BU	Maximum unbalanced weight	Standard floating point format; units: grams. Request for the maximum unbalanced weight.
BV	Minimum unbalanced weight	Standard floating point format; units: grams. Request for the minimum unbalanced weight.
UN	Unlock	Cancel the lock test command.

Calculate the maximum measuring drum unbalance as: **(BU - BV)**.

The drum unbalance should be within 3 grams. When the drum unbalance is more, check for contamination of the drum. If the unbalance is still more than 3 grams replace the drum bearings (refer to section 5.3.3).

Displacer weight

The weight of the displacer can be measured with the following procedure:

Item	Name	Description
LT	Lock test	Raise the displacer for approximately 0.6 m (2 ft) above the product level.
FR	Freeze	Stop the lock test and wait till the displacer is in a complete rest (one or two minutes).
MF	Measure frequency	Measure the frequency of the force transducer. It is ready when the status on the PET display changes from MF into FR.
WQ	Weight request	Standard floating point format; units: grams. Request for the displacer weight.
UN	Unlock	Cancel the lock test command.

Clean the displacer when the displacer's weight differs more than 3 g from the **DW**, or recalibrates with the test weights (refer to section 5.5).

For replacement of the printed circuit boards, motor block or force transducer (refer to section 5.4.2). After replacement of force transducer or motor block the force transducer requires re-calibration (refer to section 5.5).

Caution

The 854 XTG is an explosion proof instrument with intrinsically safe output/input circuits. Modification to the instrument may only be carried out by trained personnel which is authorized by Enraf.

Failure to adhere to this will invalidate the approval certificate.

5.2 Instrument covers

Opening the instrument

The joints between each cover and the housing are waterproof IP65.

For this purpose the covers of the servo, drum and terminal compartments are fitted with O-rings (refer to figure 5.1). Use a metal rod (like a Tommy bar) for opening the covers.

Check the O-rings to assure water and dust protection. Refer to Appendix A for the dimensions of O-rings.

Closing the compartment covers

In order to ensure that the covers open easily, their screw threads have been greased.

Caution

Keep screw threads free from dirt. Grease them lightly with anti seize grease before closing the instrument.

When closing, turn the covers counter-clockwise until the thread clicks into place, then turn clockwise.

5.3 Drum compartment

5.3.1 Detailed description

Figure 5.1 shows the cross-section of the gauge, including the drum compartment.

The drum shaft, mounted in the drum with a tolerance ring, is inserted into the magnet cap.

Two carbon PTFE bearings in the drum shaft bushing support the drum shaft.

These bearings should be replaced when repeatability deteriorates.

The drum shaft bushing is kept in position by a circlip. The drum shaft bushing is provided with an internal thread which facilitates removal from the magnet cap by using the drum bearing puller.

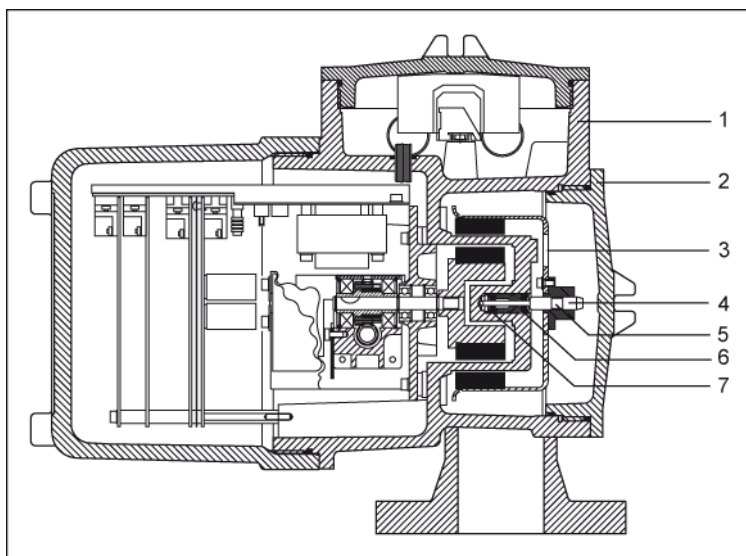

Item	Description
1	854 XTG housing
2	Drum compartment cover
3	Measuring drum
4	Drum shaft
5	Tolerance ring
6	Drum shaft bushing
7	Carbon Teflon bearings

Figure 5.1 Cross section of the drum 854 XTG level gauge

Warning

Pay attention to the kind of product in the tank. If any danger for health, wear a gas mask and take all necessary precautions.

5.3.2 Removing the measuring drum

Removing the drum from the housing requires no tools. Keep the drum, the outer magnet and the outside of the magnet cap thoroughly clean.

To remove the drum proceed as follows:

- Issue the **CA** (calibrate) command to raise the displacer
- If applicable close the ball valve and release the pressure gently.
- Give **UN** (unlock) command to lower the displacer from tank top position.
- Issue a **FR** (freeze) command when the displacer comes within reach.
- Switch-off the mains.
- Remove the drum compartment cover.
- Remove the displacer from the measuring wire. Hang a small weight on the wire to keep it positioned in the groove. Do not damage the measuring wire.
- Pull out the drum and fix the wire to the drum with a rubber band.
- Do not kink the measuring wire and handle drum carefully.

If the displacer cannot be accessed through an opening the gauge must be removed from its mounting position:

- Raise the displacer to maximum height, at least above the ball valve, when present.
- Switch-off the mains.
- If applicable close the ball valve and release the pressure gently.
- Remove the drum compartment cover.

Take off the 854 XTG, raising the displacer above the connecting flange.

- Remove the displacer from the measuring wire.
- Pull out the drum and fix the wire to the drum with a rubber band.

5.3.3 Replacing the drum bearings

- Open the drum cover.
- Take out the drum shaft bushing.
- Replace the bearings, refer to figure 5.2.
- Install the bushing.
- Install drum and displacer.
- Close the cover.

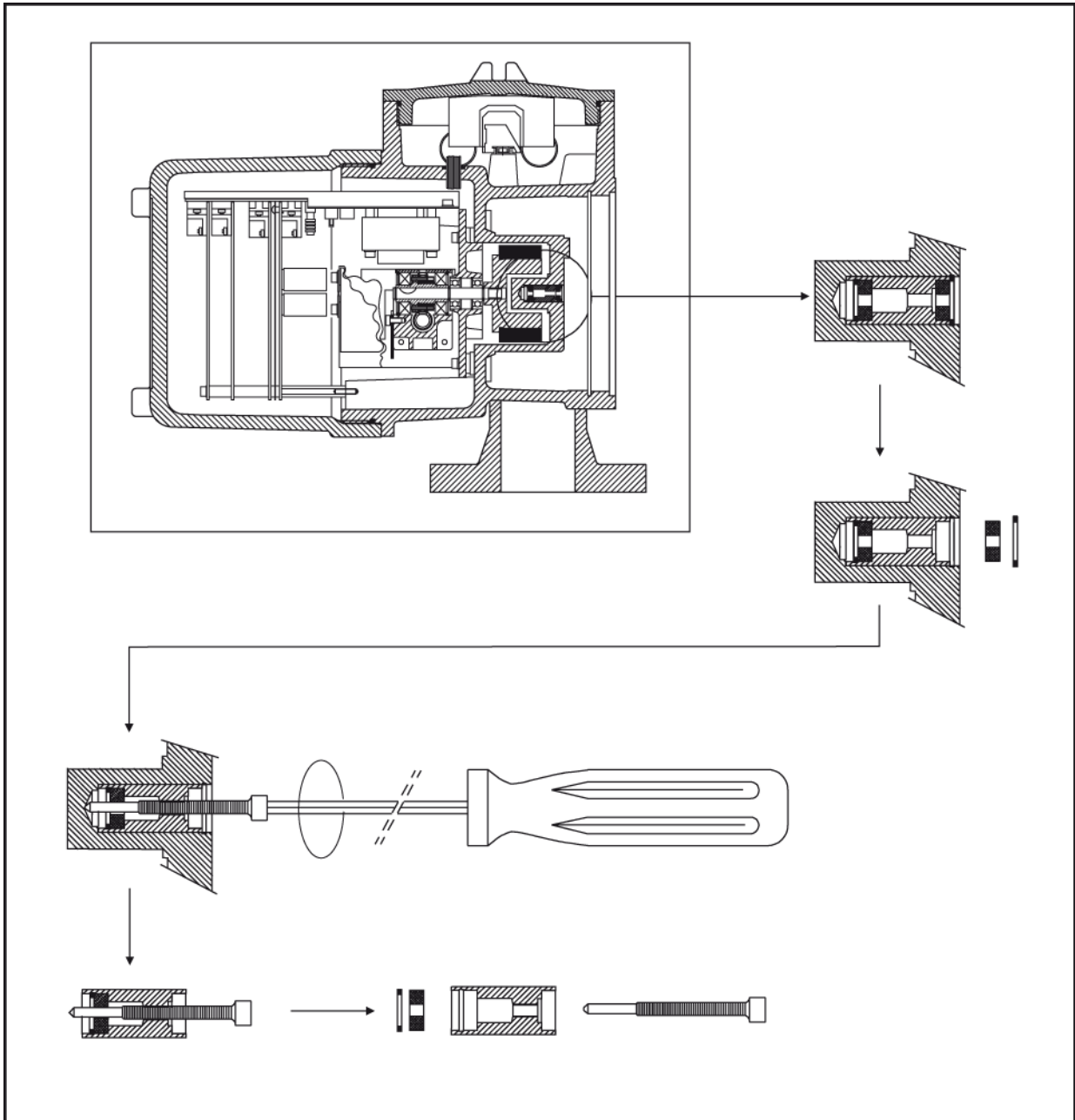

Figure 5.2 Replacing the drum shaft bearings

Caution

Do not grease the carbon PTFE bearings. The drum bearings do not require any lubricant at all.

5.4 The electronic compartment

5.4.1 Detailed description

The electronic part of the 854 XTG requires no special maintenance. However, a detailed description of the combination of the several parts is given in order to help you in case of software-updates or system enhancements.

Caution

*Never remove the electronic boards when the mains power is connected to the gauge.
It may damage the electronic circuits.*

The control hardware is concentrated in the electronic compartment, which contains a minimum number of sub-assemblies. The design of the 854 XTG is such that it makes replacement and service simple.

The electronic compartment contains the following sub-assemblies (refer to figure 5.3):

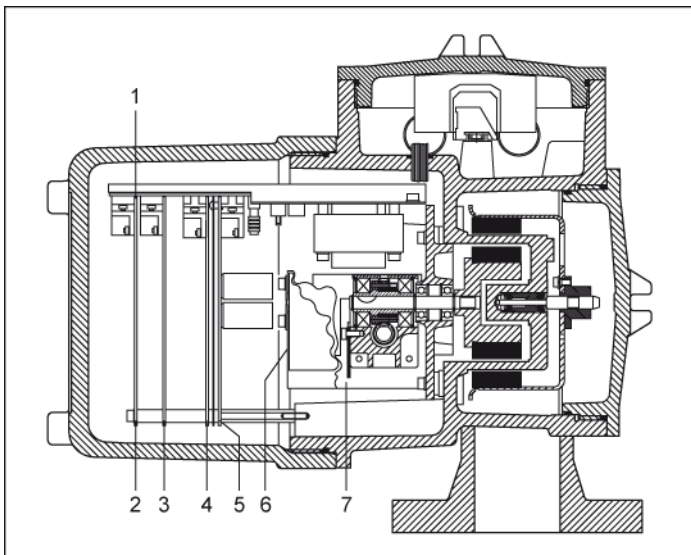

Item	Description
1	Back-plane
2	Printed circuit board XPU (Xmission Processor unit)
3	Printed circuit board SPU (Servo Processor Unit)
4	Printed circuit board (Optional board: HCU)
5	Printed circuit board GPS (Gauge Power Supply)
6	Force transducer
7	Stepper motor assembly

Figure 5.3 Cross section of the electronic and terminal Compartment

5.4.2 Dismantling the electronic compartment

Note:

Whenever the force transducer and/or motor unit have been removed the force transducer must be recalibrated (refer to section 5.5).

Warning

Before opening the electronic compartment cover, switch off power.

To remove the various components proceed as follows:

- Switch off the mains and remove the cover from the electronic compartment. Mind the setscrew! (refer to figure 3.4).
- Remove the PCB retaining screw (B), slide the locking latch (A) on the XPU board to the right (refer to figure 5.4).
- Remove the XPU board and the SPU II board.
- Disconnect non i.s. wiring from the option board, and put the board temporarily on the back-plane (still connected via ground wire and blue i.s. wires).
- Remove the GPS board.
- Remove the PCB hexagon support bar.
- Secure the motor frame with the motor block locking latch.
- Remove the flat cable connecting the motor to the back-plane.
- Disconnect the force transducer cable.
- Remove the two screws holding the force transducer by lifting it slightly in order to release the span wire from the force transducer.
- Disconnect the infra-red connector from the back-plane.

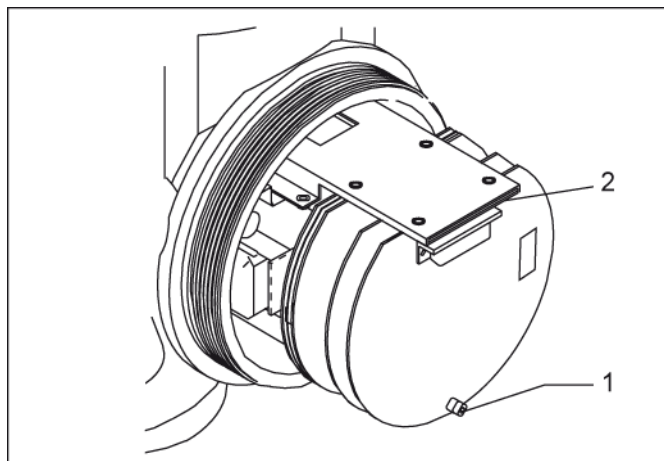

Figure 5.4 Locking latch

Caution

If the motor block needs to be removed, first remove the measuring drum (refer to section 5.3.2).

- Remove the circlip from the main shaft.
- Gently remove the motor from its shaft and remove the key.

If the back-plane must be replaced, proceed as follows:

- Disconnect the mains and transmission cabling from the back-plane
- Cut the tie-wraps retaining the wires.
- Unscrew and remove the four screws securing the back-plane frame, then remove the back-plane frame.

Assembly is done in reverse order.

Repair of the 854 printed circuit boards

Field repair of the electronic boards is not advised.

The components that can be replaced in the field are EPROMs and NOVRAM, see section 5.4.3 for updating software versions. Consult the service department of Honeywell Enraf.

5.4.3 Replacing software

The actual software version can be withdrawn by requesting for item **SV**. Compare the combination of the software versions of the XPU, SPU and optional board with the value of **SV** in the 'set-up and maintenance form' sent with every gauge.

Such a form, containing all the gauge and tank data, should always be available. Else, do commissioning, and fill-out the form before changing any EPROM or NOVRAM.

Moreover, check before changing, if the combination of the software in EPROMs, located on the various printed circuit boards, is compatible with your new software version. Carefully read the instructions which are enclosed with the new EPROMs or NOVRAM.

Refer to section 5.4.2 for dismantling the electronic compartment and removing the boards.

Note:

After installing an EPROM from a new software version the NOVRAM must be reformatted and the parameters of the gauge has to be reprogrammed. If the set-up / maintenance data is lost, go back to section 3.3.

Appendix D gives the layout of the different printed circuit boards with the position of the EPROMs and NOVRAM.

5.4.4 Initializing NOVRAM

If a new software version is installed, or a feature has been added to the 854 level gauge, NOVRAM initialization is required. With this procedure, all items are declared in the NOVRAM and filled with their default value. After the initialization, reprogramming of all items is necessary.

To initialize the NOVRAM, proceed as follows:

After the gauge is powered, issue the **IN** command by the PET 3 times in sequence. After the first command, use the '↑' key and "enter" key. No other command may interfere in this sequence.

Note:

To prevent other commands in the initialization sequence, the Enraf field bus lines may, temporary, be disconnected.

5.5 Calibrating force transducer

After mounting a new force transducer or another motor-block the force transducer must be calibrated. The frequency of the force transducer must be calibrated with help of a set of accurate test weights of 25 g, 75 g, 150 g and 225 g, all ± 0.1 g.

Check the mounting of the 854 XTG whether it is stable and horizontal.

Use the following procedure for calibration. It is assumed that the 854 XTG is fully operational. Calibration of an incompletely checked and reprogrammed gauge is not advisable.

If there is no inspection hatch, try to mount the gauge sideways, next to the original 2" flange. Check the availability of ample room to suspend (and move) the test weights (about 60 cm downwards should be sufficient).

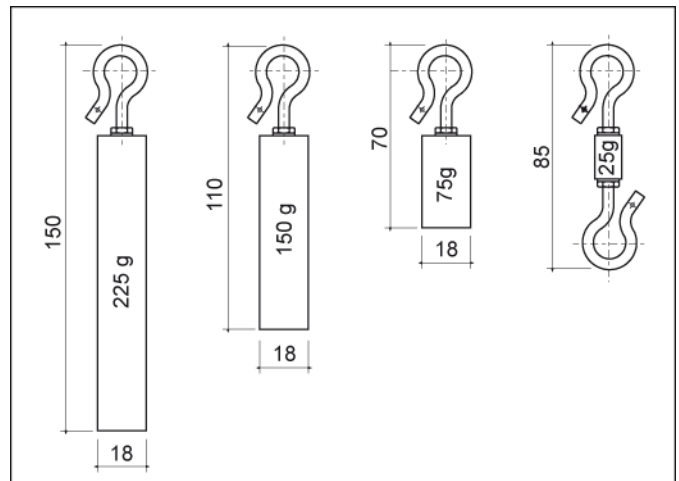

Figure 5.5 Set of test weights (#S1854061)

Force transducer calibration procedure

Item	Name	Description
W2=	Enter protection level 2	Enter protection level 2 password.
WT=	Wire rupture	Disable the wire-rupture, by setting WT to DDD. This prevents that under certain circumstances the 25 g calibration will be aborted.
EX	Exit	Exit protection level, which de-activates the wire rupture.

Remove the displacer from the measuring wire and attach the smallest test weight of 25 grams.

Item	Name	Description
LT	Lock test	Raise the displacer as high as possible until it is in full view, and good accessible.
FR	Freeze	Send a freeze command to stop the displacer movement. Correct, if necessary temporarily the motor limit high setting MH , in such a way that the gauge will automatically return to this level after a lock-test command LT .
BT	Balance test	Start a balance test. The 854 XTG will measure and calculate an average frequency at 25 g over one full drum revolution. This measurement will take approximately 5 minutes.
BF	Average measured frequency	Standard floating point format; unit: Hz. Request the average measured frequency BF after completion of the balance test and note this value for F0 . The display on the PET will show a BL (block) or FR (freeze) status.

Do not yet reprogram this value in the gauge. Reprogram all values after completion of all the four calibration measurements. Repeat this calibration from item **BT** for the other 3 test weight combinations:

- for **F1** with: (25+75 g),
- for **F2** with: (25+150 g),
- for **F3** with: (25+225 g).

Remove the test weights from the measuring wire and attach the displacer.

Program the measured frequencies:

Item	Name	Description
W2=	Protection level 2	Enter protection level 2 password.
F0=	Frequency constant 0	Standard floating point format; unit: Hz. Program frequency 0, measured with test weight of 25 g.
F1=	Frequency constant 1	Standard floating point format; unit: Hz. Program frequency 1, measured with test weight of 100 g.
F2=	Frequency constant 2	Standard floating point format; unit: Hz. Program frequency 2, measured with test weight of 175 g.
F3=	Frequency constant 3	Standard floating point format; unit: Hz. Program frequency 3, measured with test weight of 250 g.
WT=	Wire rupture	Three characters. Reprogram wire tension protection (advised setting: EDE).
EX	Exit	Exit protection level.

Note:

*A faster method of calibration is using the commands **MF** and **FQ** in stead of **BT** and **BF**. This method may not be followed when your gauge is used for density measurement via the density displacer.*

5.6 Synchronizing the reference encoder

After the installation of a new motor block or in case of mounting new software, the internal reference encoder must be synchronized to the position of the reference encoder and the gauge starts with an error code e.g. ES553 / ES555. The following procedure will do.

Item	Name	Description
W2=	Protection level 2	Enter protection level 2 password.
SM	Set maintenance	Go into maintenance mode and do not enter any command which is not specified below.
FP	Find position	The 854 XTG finds its encoder position. Wait appr. 20 seconds.
SO	Set operational	Restart in operational mode.
EX	Exit	Exit protection level and go back to operational mode.

The gauge is now ready for calibration (refer to section 3.4).

6 Trouble shooting

The 854 XTG is an instrument with self diagnostics. Detected errors can be requested as items by the PET.

The following items contain the error codes of the processor boards:

- EP** Error XPU(-2) request (communication processor unit)
- ES** Error SPU request (servo processor unit)

These items contain an error code of the last error condition. The error codes can be read as long as the gauge is not reset.

Besides the error codes, data items from level and optional functions (such as temperature and analog level output) contain one or more status bytes which also give valuable information. These bytes are readable ASCII characters. However, most of them are bit coded. Appendix C contains an ASCII table for conversion of the status bits into the actual status.

An example for a bit coded status byte:

one (of the) status byte(s) reads: **F**;
 written out in bits (refer to Appendix C): **0100 0110**;
 (b7=0, b6=1, b5=0, b4=0, b3=0, b2=1, b1=1, b0=0).

Bit 7 is always a '0' and bit 6 is always a '1' to avoid 'control' characters. Look up the relevant status byte in this section (e.g. **QS** in section 6.4) to determine the meaning of the bits which are set to '1'. Only the bits set to '1' represent an actual status.

6.1 Problems with displacer movement

If the displacer is not running freely, for instance stuck against a stilling well, it can be controlled manually.

Note:

Be aware that measuring wire is unrolled from the measuring drum. When the measuring wire is not kept at tension, the result will be an uncontrolled wire movement which results in the worst case in the lost of the measuring wire.

Item	Name	Description
W2	Protection level 2	Enter protection level 2 password.
SM	Set maintenance	Go into maintenance mode.
GD	Go down	Go down for approximately 200 mm (8").
FR	Freeze	Give the freeze command.
SO	Set operational	Exit maintenance mode
EX	Exit	Exit protection level 2

When hereafter the displacer is free and the weight is too high, the force transducer must be recalibrated. When the measured displacer weight is too far out of range, the gauge is probably not levelled within 2°. Then, improve the stability of the construction on which the gauge is mounted.

6.2 XPU error code (item EP)

The XPU error code is a three-digit number. When the XPU detects an error about a certain item, that item follows the error code, separated by a space.

For instance: 067 LL : invalid level format in item LL.

Some XPU error codes of item **EP** are listed below, with suggestions for solving the problem. For a complete overview, refer to “Item documentation for Enraf series 854 ATG” and in the item help of the service program Engauge.

000	No error	
004	Display RAM error	Set item DY to □N□
011	NOVRAM version error	New software is installed; requires NOVRAM initialization
014	NOVRAM operation error	Set item 03 to □@□; check all settings, there may be an error
017	NOVRAM init failed	NOVRAM seize too small. Use XPU-1 board with larger NOVRAM seize
021	SPU start-up failure	SPU board not well connected in backplane, or defective.
033	SPU fatal error	SPU board not well connected in backplane, or defective.
036	Jumper setting changed	Jumper setting changed while power was on. Give reset (RS) command.
040	Missing SPU board	Missing SPU board or board not well connected in backplane, or defective.
051	Unknown item	Item not known to 854 XTG, check for correct item.
053	Invalid item length	Wrong data field length, check for correct item setting.
056	Wrong protection level	First enter protection level 1 or 2.
067	Invalid level format	Check item LD , then give the setting in the correct level format.
071	Invalid decimal separator	Check item DP , then give the setting with the correct decimal separator.
076	Invalid floating point format	Give the setting in the correct floating point format (refer to section 3.3.3).
081	Command disabled by HC	Command is currently disabled by the host command (HC)
082	Invalid password	Give the correct password for W1 and W2 .
096	Password read not allowed	Password read access not allowed
101	Watchdog error	The watchdog reset is a sign that there is a serious fault, caused by interference, or a faulty XPU board.
136	SPU board not responding	Missing SPU board, or SPU board not well connected in backplane, or SPU board defective.
137	Optional board not responding	Missing optional board, or optional board not well connected in backplane, or optional board defective.
999	Fatal XPU error	Serious internal XPU software error; check contents of item 00 and report to Enraf Delft.

6.3 SPU error code (item ES)

The SPU error code is a four-digit number. Some SPU error codes of item **ES** are listed below, with suggestions for solving the problem. For a complete overview, refer to “Item documentation for Enraf series 854 level gauges” and in the item help of the service program Engauge.

0000	No error	
0104	F0 range error	Frequency constant 0 value is out of range (probably after NOVRAM init). Give correct setting in item F0 , or calibrate force transducer (refer to section 5.5).
0407	Force transducer initialisation error	The force transducer does not start-up correctly, or the motor unit has not been unlocked.
0553	Reference encoder error 1	A minimum correlation between the reference encoder table and the values read from the actual reference encoder is not achieved. Either stepper motor or the reference encoder is defective or filthy. Check motor and reference encoder (excessive oil?).
0554	Reference encoder error 2	
0555	Reference encoder error 3	Motor slack of more than ¼ revolution appeared. Recalibrate the gauge.
0601	Force transducer error 1	Frequency of the force transducer is too low
0602	Force transducer error 2	Frequency of the force transducer is too high
0605	No wire tension	A wire rupture was detected or the motor unit has not been unlocked, or the force transducer is defective.
0610	Wire tension too low	The wire tension has been too low for a while. Solve the problem or adjust item ML .
0611	Wire tension too high	The wire tension has been too high for a while. Solve the problem; clean the displacer.

6.4 SPU status request (item QS)

The servo status request (item **QS**) consists of four bytes. Bytes 0, 1 and 2 are bit coded with information about the level alarms, operational mode and general status. Byte 3 is an ASCII character that indicates the active operational command.

Status byte 0:

- bit 0 : low level alarm
- 1 : low low level alarm
- 2 : high level alarm
- 3 : high high level alarm
- 4 : motor limit switch low
- 5 : motor limit switch high
- 6 : 1
- 7 : 0

Status byte 1:

- bit 0 : displacer movement down
- 1 : displacer movement up
- 2 : on level
- 3 : test flag
- 4 : calibration test successful
- 5 : calibration test failed
- 6 : 1
- 7 : 0

Status byte 2:

- bit 0 : Active interface bit 0
- 1 : Active interface bit 1
- 2 : dipped level
- 3 : 0
- 4 : general fail indication
- 5 : no previous **ST**, **WD** or **SD** command
- 6 : 1
- 7 : 0

Active interface:

bit 1	bit 0	Mode
0	0	I1
0	1	I2
1	0	I3
1	1	dip

Status byte 3:

- | | |
|-----------------------|-----------------------|
| - : no command active | N : interface profile |
| A : balance test | L : lock test |
| B : Block | M : measure frequency |
| C : calibrate | R : tank profile |
| D : go down | T : test gauge |
| F : freeze | U : go up |

Appendix A Article and part numbers

No.	Description	Part no.
1	drum with 27 m stainless steel wire and shaft	S0854962
	drum with 37 m stainless steel wire and shaft	S0854963
	drum with 150 m stainless steel wire	S0854325
2	key	S6576001
3	main shaft with magnet	S0894340
4	set of O-rings for 854 XTG	S0854967
5	terminal assembly	S0894305
9	GPS printed circuit board	S0854615
	Set of fuses (10 pc. 250 mA, 250 V and 10 pc. 1 A, 250 V)	S0854970
10	back-plane assembly (including transformer)	
	230 V	S0894950
	220 V	S0894951
	130 V	S0894952
	110 V	S0894953
11	HCU optional printed circuit board for:	
	VITO temperature and/or water probe	S0854930
	VITO temperature and/or water probe + HART device(s)	S0854931
	Analog level output	S0854935
	EPROM programmed for HCU / ICU_HPI	S0181311
12	SPU II printed circuit board without hardware alarms	S0854611
	SPU II printed circuit board with hardware alarms	S0854612
	EPROM programmed for SPU II alarms	S0181172
	EPROM programmed for SPU II alarms + servo density	S0181173
13	XPU-2 printed circuit board including EPROM and NOVDRAM:	
	standard	S0894920
	with i.s. output for TSI	S0894921
	with RS-232C + MODBUS communication channel	S0894965
	with RS-485 + MODBUS communication channel	S0894968
	EPROM programmed for XPU-2 (all options)	S0181176

No.	Description	Part no.
16	pull wire	S0854151
17	force transducer	S0854485
19	motor connection board	S0894601
20	motor unit assembly	S0854957
21	ball bearing (set of 2 pc.)	S2100418
22	IR connector (chassis part)	S0854380
23	displacer, material PTFE (25% carbon)	
	25 mm	S0815360
	45 mm	S0815343
	90 mm	S0815344
	110 mm	S0815345
	140 mm	S0815330
	displacer, material stainless steel (for density measurement)	
	45 mm	S0815355
	90 mm	S0815350
24	set drum bearings (2 pc.) including circlips, bushing and drum shaft set of 20 pc. drum bearings and circlips	S0854953 S0854955
M	measuring wire, stainless steel AISI 316, 30 m	S0802801
	measuring wire, stainless steel AISI 316, 40 m	S0802856
	measuring wire, stainless steel AISI 316, 1500 m	S0802806
	measuring wire, Hastelloy, 30 m	S0802861
	measuring wire, Hastelloy, 40 m	S0802862
	measuring wire, INVAR, 30 m	S0802840
	measuring wire, INVAR, 40 m	S0802841
	measuring wire, Tantalum, 30 m	S0802851
	measuring wire, Tantalum, 40 m	S0802850
R	anti seize grease	S4000015

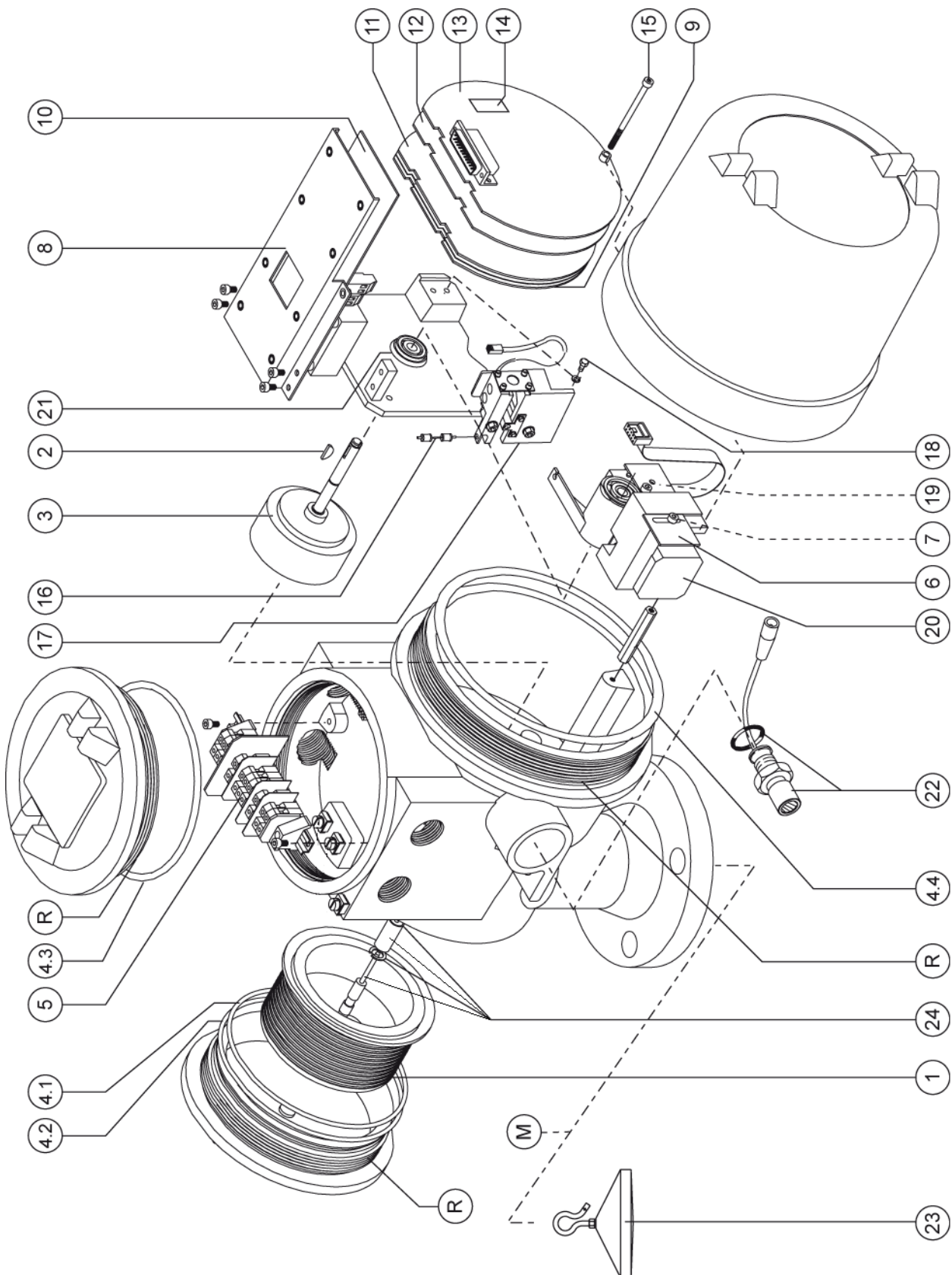

Appendix B Additional information on displacers

Displacer type	Part number	Displacer area (DA) [cm ²]	Displacer volume (DV) [cm ³]	Displacer weight (DW) [g]
Carbon filled PTFE				
ø 25 mm	S0815360	+ .10000000E+02	+ .10500000E+03	+ .22300000E+03
ø 45 mm	S0815343	+ .16000000E+02	+ .10500000E+03	+ .22300000E+03
ø 90 mm	S0815344	+ .64000000E+02	+ .10500000E+03	+ .22300000E+03
ø 110 mm	S0815345	+ .95000000E+02	+ .10500000E+03	+ .22300000E+03
Stainless steel				
ø 90 mm	0815.171	+ .64000000E+02	+ .60000000E+02	+ .22300000E+03
ø 110 mm	0815.173	+ .95000000E+02	+ .10000000E+03	+ .22300000E+03
ø 140 mm	0815.175	+ .15400000E+03	+ .17500000E+03	+ .22300000E+03
Density displacer (stainless steel)				
ø 90 mm	S0815350	+ .64000000E+02	approximately 200; exact value is engraved on displacer	approximately 265; exact value is engraved on displacer
ø 43 mm	S0815355	+ .16000000E+02		

Standard displacer

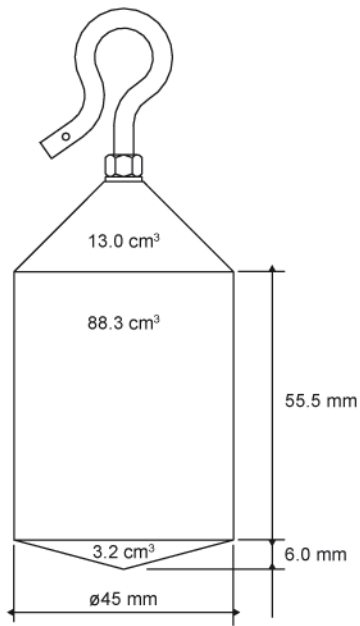

223 g
0815.343

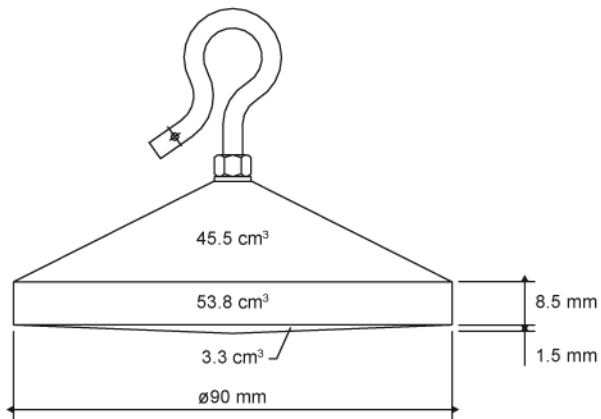

223 g
0815.344

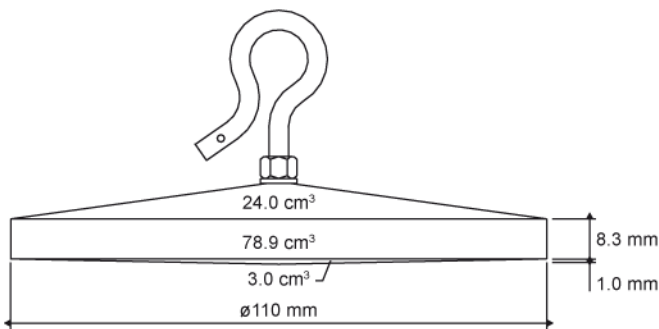

223 g
0815.345

Density displacer

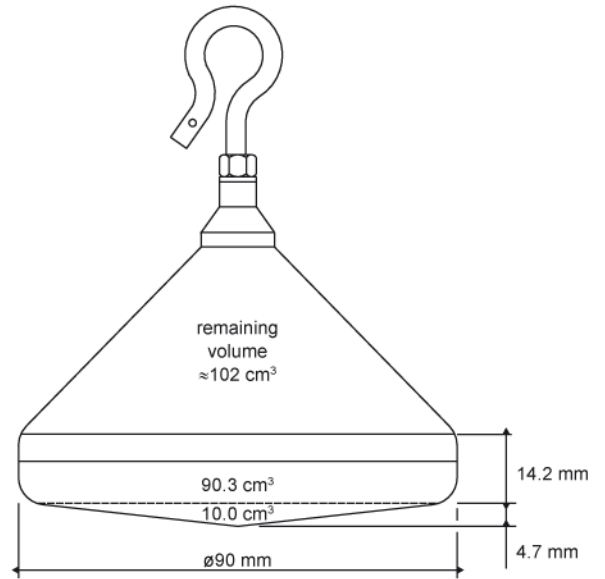

≈265 g
0815.350

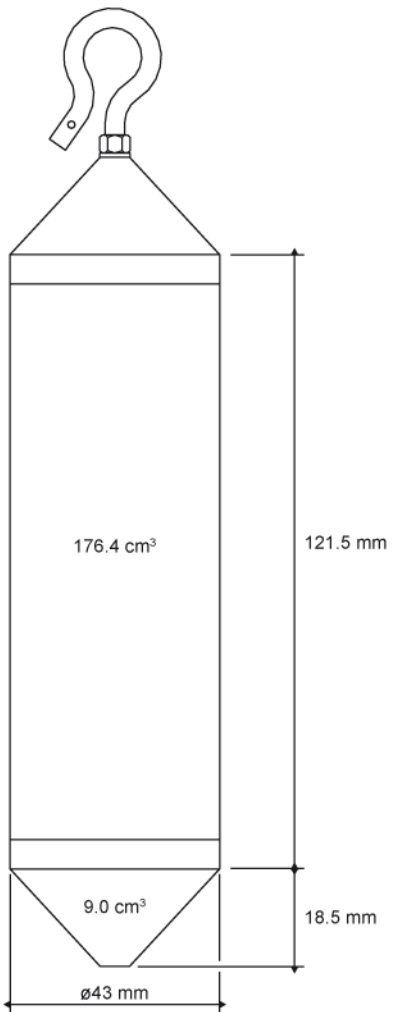

≈265 g
0815.355

Appendix C ASCII table

HEX	MSB				0	1	2	3	4	5	6	7
	BIT				6 5 4	6 5 4	6 5 4	6 5 4	6 5 4	6 5 4	6 5 4	
	3	2	1	0	0 0 0	0 0 1	0 1 0	0 1 1	1 0 0	1 0 1	1 1 0	1 1 1
0	0	0	0	0	NUL	DLE	SP	0	@	P	`	p
1	0	0	0	1	SOH	DC1	!	1	A	Q	a	q
2	0	0	1	0	STX	DC2	"	2	B	R	b	r
3	0	0	1	1	ETX	DC3	#	3	C	S	c	s
4	0	1	0	0	EOT	DC4	\$	4	D	T	d	t
5	0	1	0	1	ENQ	NAK	%	5	E	U	e	u
6	0	1	1	0	ACK	SYN	&	6	F	V	f	v
7	0	1	1	1	BEL	ETB	'	7	G	W	g	w
8	1	0	0	0	BS	CAN	(8	H	X	h	x
9	1	0	0	1	HT	EM)	9	I	Y	i	y
A	1	0	1	0	LF	SUB	*	:	J	Z	j	z
B	1	0	1	1	VT	ESC	+	;	K	[k	{
C	1	1	0	0	FF	FS	,	<	L	\	l	
D	1	1	0	1	CR	GS	-	=	M]	m	}
E	1	1	1	0	SO	RS	.	>	N	^	n	~
F	1	1	1	1	SI	US	/	?	O	-	o	DEL

Appendix D PCB layout

EPROM

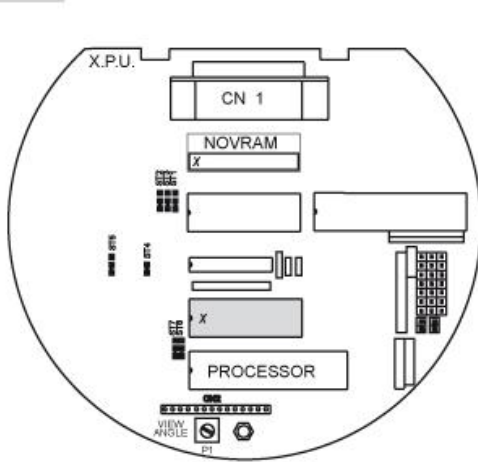

XPU 1

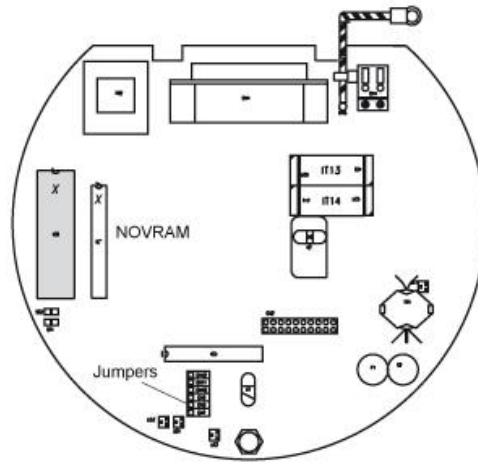

XPU-2

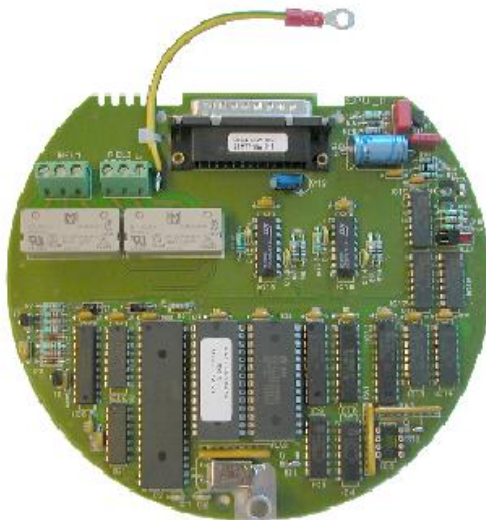

SPU II



HCU

Appendix E Related documents

Installation guide 854 XTG level gauge
Safety manual series 854 ATG/XTG level gauges

Instruction manual SPU II Hard alarm output contacts
Instruction manual 854 density option
Instruction manual XPU-2 option RS-232C / RS-485

Instruction manual Spot temperature and analog output
Instruction manual VITO
Instruction manual HIMS/HTG

Instruction manual 977 Tank Side Indicator

Item documentation for Enraf series 854 level gauges, 97x SmartRadar and 877 FDI

Instruction manual 847 Portable Enraf Terminal
Instruction manual Engauge service tool

Protocol manual for 854 series level gauges

Index

Accept reference	22, 23	Drum compartment	33
AH	20	Drum shaft	12, 33
Alarm relays	7, 8	bushing.....	33, 35
Alarm settings	20	DV	24
Analog level output	8	DW	19, 24
AR	22, 23	Electronic compartment.....	37
Average measured frequency	31, 39	Encoder disk.....	7
Average measured weight.....	31	ENRAF1	21
Average temperature	8	ENRAF2	16, 17, 19, 21
Back-plane	36	Ensite	14
Balance test	31, 32, 39	EP	31, 42
Ball valve	23, 30, 34	EPROM	37, 39
BF	31, 39	Error SPU request.....	31, 42
BL.....	25, 31	Error XPU request.....	31, 42
Block	25, 31	ES.....	31, 42
mode.....	26	EX.....	14, 16, 17, 19
Blocking facilities	9	Exit.....	14, 16, 17, 19
BM.....	26	Explosion proof	9, 33
BT.....	31, 32, 39	F0	39, 40
BU	31, 32	F1, F2, F3	40
BV	31, 32	FDI.....	8
BW	31	Feet.....	17
CA	22, 23, 27, 31	Find position	40
Calibrate	22, 23, 27, 31	Force transducer.....	7, 13, 36, 37
Carbon PTFE bearings	33	calibration	39
Caution	10	FP	40
CIU.....	19	FQ.....	31, 40
Commands.....	14, 31	FR.....	16, 23, 25, 30-32, 41
Compensated servo innage	22, 27, 31	Fractions	17
Covers	33	Freeze.....	16, 23, 25, 30-32, 41
CPI	8	Frequency constant 0, 1, 2, 3.....	40
CQ.....	22, 27, 31	Frequency request.....	31
DA	19	Gauge data.....	18
Data items	31	Gauge type.....	19
Data requests	14	GD	41
Datum plate	21	Go down	41
DC.....	19	GPS	36, 37
DE.....	21	Grease	33
Decimal separator	17	GT.....	19
Density	7, 8	HA.....	20
displacer	12, 19, 40	HC.....	42
product.....	24	Health.....	10
water.....	24	HH.....	20
DH.....	27	Highway.....	19
Dip height	27	Host command.....	42
Dip mode	27, 31	I1.....	28, 30
Dip time interval	27	I2, 3.....	26, 28, 31
Displacer.....	7, 12, 22, 34, 35, 39, 41	Immersion depth	23, 24
area	19	IN.....	38
hook.....	12	Inches	17
volume	7, 12, 24	Infra-red connector.....	37
weight	7, 12, 19, 24, 32, 41	Initialize	19
DM	27, 31	Innage	21
DP.....	17	Instrument covers	33
Drum circumference	12, 19	Interface	7

Interface 1	26, 31	PET	9, 14, 16
Interface 2, 3	24, 26, 31	PL	31
Intrinsically safe	9, 33	Portable Enraf Terminal	9, 14
Items	14	Power	16
format depended	17	Pressure	8
JS	14	Printed circuit board	37
Jumper setting	14	Product measurement	26
L3	24	Protection level 1	15
LA	20	Protection level 2	15-17, 19
LD	17	PX	29
Level alarm	20	PY	29
high	20	PZ	29
high high	20	QS	31, 43
hysteresis	20	Reference encoder	7
low	20	synchronizing	40
low low	20	Reference level	16, 22, 23, 30
Level dimension	17	Repeatability test	22, 25, 32
Level offset I3	24	Reset	16
Level type	21	RL	16, 22, 23, 30
LL	20	RS	16
Lock test	25, 31	RS-232C	8
limit switch	25	RS-485	8
limit switch level	19	S1	19
Locking latch	13, 37	S3	24
Log file	14	Safety	9, 10
LQ	31	SE	28
LT	25, 31	Servo Auto Test	28
Magnet		Servo innage	31
cap	33	Servo status request	31
coupling	7, 9	Servo ullage	31
Manual dipping	22	Set maintenance	40, 41
Maximum unbalanced weight	31, 32	Set operational	40, 41
Measure frequency	31, 32	Set point 1	19
Measuring drum	7, 12, 41	Set point 3	24
bearings	35	SH	28
removing	34	SI	28
unbalance	32	SM	40, 41
Measuring wire	7, 12, 34, 41	SN	29
weight compensation	19	SO	40, 41
Metres	17	Software version	17, 38
MF	31, 32, 40	Span wire	13, 37
MH	19	Spot temperature	8
Minimum unbalanced weight	31, 32	SPU	36, 37
ML	19	status request	43
Motor block	13, 36, 37, 40	Standard floating point format	17
Motor limit switch high	19	Stepper motor	7
position	22	SV	17, 38
Motor limit switch low	19	SY	28
Motor shaft	7	SZ	29
MZ	19, 25	TA	19
Note	10	Tank adapter	22
NOVRAM	37, 38	Tank data	18
initialization	38	Tank identifier	19
settings	14	Tank Side Indicator	8
Optional board	36	Tank top	19, 22, 27
Password 1	15, 21	Tank top reference stop	22, 27
Password 2	15-17, 19, 21	Test gauge	25, 31
PCB retaining screw	37	Test weight	12, 39
PE	31	TG	25, 31

TI.....	19	Transmission speed.....	19
Tool set.....	11	TS	19
Top of ball valve	23	TSI	8
Transmission address.....	19	TT	19, 22, 27
Ullage	21	Warranty	2
UN.....	16, 23, 26, 27, 31	Water bottom probe	8
Unlock	16, 23, 26, 27, 31	Water measurement	26
Upper reference	21	Weight request	31, 32
point.....	21	Weights & Measures.....	14
UQ.....	31	Wire rupture	39, 40
UR.....	21	WQ	29, 30
Verify level calibration	27	WT.....	39, 40
W&M	14	XI	29
protection	15	XPU.....	36, 37
W1	15, 21	jumpers.....	15
W2	15-17, 19, 21	XPU-2.....	17
Warning.....	10	XTI	31
		XTG.....	6, 16

Honeywell Enraf

Delftechpark 39

2628 XJ Delft

The Netherlands

Tel: +31 (0)15-2701 100

Email: hfs-tac-support@honeywell.com

www.honeywellenraf.com

Honeywell Enraf

4416275 - Revision 6
September 2013
© 2013 Honeywell International Inc.