

SITRANS P, Series DSIII Transmitter
for
Pressure, Differential Pressure,
Flanged Level, and Absolute Pressure
Model 7MF4*33-...



IMPORTANT

MODEL 275 HART COMMUNICATOR AND MODEL 375 FIELD COMMUNICATOR

Many procedures, screens, and wiring diagrams shown in this manual feature the Model 275 HART Communicator.

The Model 375 Field Communicator is now available. Procedures and screens are similar to those for the Model 275, however, there are significant differences and an online Configuration Map for use with the Model 375 is provided at the back of this manual.

Transmitter model and firmware version can affect the displays, display options, and Configuration Maps.

Whether using the Model 275 or the Model 375, be sure to read the manual supplied by the manufacturer before installing or using the device. Refer to the device's nameplate for hazardous area certifications and approvals and other important information.

APPLICATION AND MODEL QUICK LOCATOR

The following table provides an overview of measurement categories and available models. For details pertaining to a particular model, see its model designation table and its specification table in Section 9 Model Designations and Specifications. To quickly locate other information, refer to the Table of Contents.

Measurement	Models	Model Designation	Specifications	Dimensions
Absolute or Gauge Pressure	7MF4033	Table 9-1	Table 9-15	Figure 9-1
	7MF4233	Table 9-2	Table 9-16	Figure 9-1
	7MF4333	Table 9-3	Table 9-16	Figure 9-2
Differential Pressure	7MF4433	Table 9-4	Table 9-15	Figure 9-2 or 9-3
	7MF4533	Table 9-5	Table 9-15	Figure 9-2 or 9-3
Level (Flange)	7MF4633	Table 9-6	Table 9-16	Figure 9-4
	7MF4912	Table 9-6	Table 9-16	Figure 9-4

TABLE OF CONTENTS

SECTION AND TITLE	PAGE
1.0 INTRODUCTION.....	1-1
1.1 CONTENTS	1-1
1.2 PRODUCT DESCRIPTION.....	1-2
1.3 RATING, APPROVAL, AND TAG PLATES.....	1-9
1.4 CONFIGURATION	1-9
1.5 PRODUCT SUPPORT	1-10
2.0 MODEL 275 UNIVERSAL HART COMMUNICATOR	2-1
2.1 INTRODUCTION	2-1
2.2 COMMUNICATOR CONNECTIONS.....	2-1
2.3 CONTROLS OVERVIEW	2-4
2.3.1 Liquid Crystal Display	2-4
2.3.2 Software-Defined Function Keys.....	2-4
2.3.3 Action Keys.....	2-6
2.3.4 Alphanumeric and Shift Keys.....	2-7
2.3.4.1 Rapid Selection of Menu Options	2-7
2.3.4.2 Data Entry	2-7
2.4 GETTING TO KNOW THE COMMUNICATOR	2-8
2.4.1 Display Icons	2-8
2.4.2 Menu Structure	2-9
2.4.3 Reviewing Installed Devices	2-9
2.5 MAIN MENU.....	2-11
2.5.1 Offline Menu	2-12
2.5.1.1 New Configuration.....	2-13
2.5.1.2 Saved Configuration.....	2-16
2.5.2 Online Menu.....	2-18
2.5.3 Frequency Device Menu.....	2-21
2.5.4 Utility Menu	2-21
2.5.4.1 Configure Communicator.....	2-21
2.5.4.2 System Information	2-22
2.5.4.3 Listen for PC	2-22
2.5.4.4 Storage Location	2-22
2.5.4.5 Simulation	2-22
2.5.4.6 Selftest.....	2-22
2.6 USING THE QUICK ACCESS KEY	2-23
2.6.1 Adding Quick Access Key Options.....	2-24
2.6.2 Deleting Quick Access Key Options.....	2-25
3.0 PRE-INSTALLATION TEST	3-1
3.1 PROCEDURE.....	3-1
3.1.1 Test Equipment.....	3-2
3.2 ESTABLISHING COMMUNICATION.....	3-3
3.3 TESTING THE TRANSMITTER.....	3-3
3.4 REVIEWING CONFIGURATION DATA.....	3-4
3.5 CHECKING TRANSMITTER OUTPUT	3-4
4.0 INSTALLATION.....	4-1
4.1 EQUIPMENT DELIVERY AND HANDLING.....	4-1

4.1.1 Receipt of Shipment	4-1
4.1.2 Storage.....	4-1
4.2 ENVIRONMENTAL CONSIDERATIONS	4-2
4.3 PRE-INSTALLATION CONSIDERATIONS AND CALCULATIONS.....	4-2
4.3.1 Mechanical	4-2
4.3.2 Electrical.....	4-3
4.3.3 Impulse Piping for Absolute and Differential Models	4-4
4.3.4 Transmitter Operating Mode and Network Type	4-10
4.3.4.1 Analog Mode.....	4-10
4.3.4.2 Digital Mode	4-14
4.3.5 Power Supply Requirements	4-14
4.3.5.1 Point-to-Point Network	4-16
4.3.5.2 Multi-Drop Network.....	4-16
4.3.6 Determining Network (Loop) Length.....	4-17
4.3.6.1 Cable Capacitance	4-17
4.3.6.2 Maximum Cable Length Calculation	4-17
4.3.7 Network Junctions	4-18
4.3.8 Safety Barriers	4-19
4.3.9 Connection of Miscellaneous Hardware.....	4-19
4.3.10 Shielding and Grounding.....	4-20
4.4 MECHANICAL INSTALLATION.....	4-21
4.4.1 Pipe Mounting, Differential and Gauge Construction.....	4-21
4.4.2 Direct Mounting to Process, Model 7MF4433 or 7MF4533	4-23
4.4.3 Flange Mounting, Model 7MF4633/7MF4912.....	4-24
4.5 MECHANICAL INSTALLATION, ALL MODELS.....	4-26
4.5.1 Enclosure Rotation	4-26
4.5.2 Display Orientation	4-27
4.5.3 Electrical Conduit and Cable Installation.....	4-28
4.5.3.1 Conduit.....	4-28
4.5.3.2 Cables	4-29
4.5.3.3 Access to Transmitter Terminal Compartment	4-29
4.6 ELECTRICAL INSTALLATION	4-30
4.7 HAZARDOUS AREA INSTALLATION.....	4-32
5.0 POST-INSTALLATION TEST.....	5-1
5.1 TEST EQUIPMENT.....	5-1
5.2 INSTALLATION REVIEW.....	5-1
5.3 EQUIPMENT CONNECTION	5-2
5.4 VERIFICATION	5-3
5.4.1 Communication Test	5-3
5.4.2 Transmitter Selftest	5-3
5.4.3 Loop Test.....	5-4
5.5 TRANSMITTER ZERO AND SHUTOFF VALVE MANIPULATION.....	5-5
5.5.1 Absolute Pressure	5-5
5.5.1.1 Measuring Gases	5-6
5.5.1.2 Measuring Vapor and Liquid	5-7
5.5.2 Differential Pressure and Flow.....	5-8
5.5.2.1 Measuring Gases	5-8
5.5.2.2 Measuring Liquids.....	5-9
5.5.3 Measuring Vapor.....	5-11

6.0 ON-LINE CONFIGURATION AND OPERATION.....	6-1
6.1 LOCAL OPERATION AND DISPLAY	6-1
6.1.1 Digital Display.....	6-1
6.1.2 Numeric Display.....	6-2
6.1.3 Unit/Bargraph Display.....	6-3
6.1.4 Error Message.....	6-3
6.1.5 Output Signal Range.....	6-3
6.1.6 Mode Display	6-4
6.2 LOCAL OPERATION WITH THE MAGNETIC PUSHBUTTONS.....	6-5
6.2.1 Cancel Pushbutton Disable and Write Protection.....	6-7
6.2.2 Set/Adjust Zero and Full Scale.....	6-7
6.2.2.1 Theoretical Relationships.....	6-7
6.2.2.2 Practical Applications	6-9
6.2.3 Electric Damping.....	6-10
6.2.4 Blind Setting of Zero and Full Scale	6-10
6.2.4.1 Theoretical Relationships.....	6-10
6.2.4.2 Practical Applications	6-11
6.2.5 Zero Adjustment (Position Correction).....	6-12
6.2.5.1 Zero-Point Alignment at Absolute Pressure.....	6-12
6.2.6 Fixed Current Output.....	6-13
6.2.7 Failure Current.....	6-13
6.2.8 Pushbutton and Function Disable.....	6-14
6.2.9 Flow Measurement (Differential Pressure only)	6-14
6.2.10 Select Measured Value to be Displayed.....	6-16
6.2.11 Select the Displayed Input Pressure Engineering Unit.....	6-16
6.3 LOCAL OPERATION WITHOUT A DISPLAY OR WITH ACTIVATED KEYLOCK	6-18
6.3.1 Set Zero and Full Scale.....	6-18
6.4 REMOTE CONFIGURATION AND OPERATION BY HART	6-20
6.4.1 Process Data	6-20
6.4.2 Setting Zero and Full Scale	6-21
6.4.3 Blind Setting of Zero and Full Scale	6-21
6.4.4 Zero Adjustment for Position Correction.....	6-21
6.4.5 Electric Damping.....	6-22
6.4.6 Fast Measured Value Acquisition (fast response mode)	6-22
6.4.7 Fixed Current Output.....	6-23
6.4.8 Fault Current.....	6-23
6.4.9 Disabling the Transmitter Magnetic Pushbuttons and Write Protection	6-24
6.4.10 Measured Value Display	6-25
6.4.11 Select Pressure Engineering Units.....	6-25
6.4.12 Display/Bargraph.....	6-25
6.4.13 Sensor Trim	6-26
6.4.13.1 Trimming the Lower Sensor Adjustment Point.....	6-26
6.4.13.2 Trimming the Upper Sensor Adjustment Point.....	6-27
6.4.14 D/A Trim	6-28
6.4.15 Transmitter Current Adjustment.....	6-28
6.4.16 Factory Calibration (Manufacturer Trims).....	6-29
6.4.17 Device Information.....	6-30
6.4.18 Flow Measurement (Differential Pressure)	6-30
6.4.19 Diagnostic Functions	6-30
6.4.19.1 Operating Hours Counter	6-31
6.4.19.2 Calibration Timer and Service Timer.....	6-31
6.4.19.3 Min/Max Pointer	6-32

6.4.19.4 Monitoring the Saturation Current	6-32
6.4.20 Simulation.....	6-33
6.4.21 Self Test and Master Reset	6-35
7.0 CALIBRATION AND MAINTENANCE.....	7-1
7.1 CALIBRATION	7-2
7.2 PREVENTIVE MAINTENANCE	7-3
7.2.1 Transmitter Exterior Inspection.....	7-3
7.2.2 Transmitter Exterior Cleaning	7-3
7.2.3 Transmitter Enclosure Interior Inspection	7-4
7.2.4 Transmitter Calibration.....	7-4
7.2.5 Impulse Piping.....	7-4
7.3 TROUBLESHOOTING	7-5
7.3.1 Analog Output	7-5
7.3.2 Digital Output (Communication).....	7-8
7.4 ASSEMBLY REMOVAL AND REPLACEMENT	7-9
7.4.1 Display Assembly.....	7-11
7.4.2 Replacing the Electronics Module.....	7-12
7.4.3 Measuring Cell Assembly Removal and Replacement	7-13
7.4.4 Terminal Board Assembly Removal and Replacement.....	7-16
7.5 NON-FIELD-REPLACEABLE ITEMS.....	7-16
7.6 TRANSMITTER REPLACEMENT	7-17
7.7 MAINTENANCE RECORDS.....	7-18
7.8 RECOMMENDED SPARE AND REPLACEMENT PARTS.....	7-18
7.9 COMPATIBILITY, REVISION NUMBERS	7-19
8.0 CIRCUIT DESCRIPTION	8-1
8.1 OVERALL OPERATION	8-2
8.2 PRESSURE.....	8-2
8.3 DIFFERENTIAL PRESSURE AND FLOW	8-3
8.4 FLANGED LEVEL	8-3
8.5 ABSOLUTE PRESSURE (DIFFERENTIAL CONSTRUCTION)	8-4
8.6 ABSOLUTE PRESSURE (GAUGE CONSTRUCTION)	8-4
8.7 COMMUNICATION FORMAT	8-5
9.0 MODEL DESIGNATIONS AND SPECIFICATIONS	9-1
9.1 MODEL DESIGNATIONS.....	9-1
9.2 ACCESSORIES.....	9-20
9.3 SPECIFICATIONS.....	9-21
9.4 MEASURING SPANS AND OVERLOAD LIMITS	9-29
9.5 NETWORK TOPOLOGY	9-35
9.5.1 Two-Wire Cable	9-35
9.6 HAZARDOUS AREA CLASSIFICATIONS	9-35
9.6.1 CSA Hazardous Locations Precautions.....	9-36
10.0 GLOSSARY.....	10-1
A.0 APPENDIX A - ONLINE CONFIGURATION MAP	A-1
B.0 APPENDIX B - HAZARDOUS AREA INSTALLATION.....	B-1

C.0 APPENDIX C - ELEVATION AND SUPPRESSION CORRECTIONS	C-1
C.1 HOW ADJUSTMENT IS MADE	C-1
C.2 ELEVATION CALCULATION EXAMPLE	C-2
C.3 SUPPRESSION CALCULATION EXAMPLE.....	C-2
C.4 RECOMMENDED METHOD.....	C-3
WARRANTY.....	W1
ONLINE CONFIGURATION MAPS.....	At back of manual
When using the Model 275 Universal HART Communicator	
When using the Model 375 Field Communicator	

LIST OF ILLUSTRATIONS

FIGURE AND TITLE	PAGE
1-1 Gauge Construction, Pressure and Absolute Models.....	1-3
1-2 Differential Construction; Differential, Flow, and Absolute Models	1-4
1-3 Differential Pressure and Flow Models with H03 Option	1-5
1-4 Flanged Liquid Level Models.....	1-6
1-5 Traditional Application.....	1-7
1-6 Display.....	1-8
1-7 Field Terminals.....	1-8
2-1 Model 275 Universal HART Communicator.....	2-2
2-2 HART Communicator Connections to a Transmitter Loop.....	2-3
2-3 HART Communicator Display Icons	2-8
2-4 Offline Menu Map.....	2-12
2-5 SITRANS P Online Menu Map.....	2-19
2-6 Generic Online Menu Map.....	2-20
3-1 Bench Test Connections	3-1
3-2 Field Test Connections	3-2
4-1 Differential Flow Measurement Piping for Gas and Liquid.....	4-5
4-2 Differential Liquid Measurement Piping.....	4-6
4-3 Absolute or Gauge Pressure Measurement Piping	4-7
4-4 Steam Service, Below the Line Mounting.....	4-8
4-5 Open and Closed Tank Level Measurement, Flange Mounted Transmitters	4-9
4-6 Point-To-Point Network (Analog Mode).....	4-11
4-7 Procidia to Transmitter Connections (Analog Mode).....	4-12
4-8 Model 353/354 to Transmitter Connections (Analog Mode)	4-13
4-9 Multi-Drop Network (Digital Mode).....	4-15
4-10 Pipe Mounting, Gauge Construction	4-22
4-11 Pipe Mounting, Differential Construction	4-22
4-12 Differential Construction, Position Options	4-23
4-13 Enclosure Rotation Considerations.....	4-26
4-14 Display Removal and Repositioning	4-27
4-15 Conduit Drain and Explosion Proof Installations.....	4-28
4-16 Network Conductor Terminations	4-31
5-1 Equipment Connection for System Checkout.....	5-2
5-2 Measuring Gases.....	5-6

5-3 Measuring Vapor and Liquid..... 5-7
 5-4 Measuring Gases..... 5-9
 5-5 Measuring Liquids..... 5-10
 5-6 Measuring Vapor..... 5-11

6-1 Digital Display..... 6-1
 6-2 Switch Point of the Square Root Characteristic..... 6-15
 6-3 Displayable Engineering Units..... 6-17
 6-4 Sensor (Measuring Cell) Trim..... 6-27
 6-5 Pressure Min/Max Pointer Example..... 6-32
 6-6 Saturation Monitoring Examples..... 6-33
 6-7 Simulation Circuit Diagram..... 6-34

7-1 Transmitter Exploded View..... 7-9
 7-2 Display Assembly Installed and Partially Removed..... 7-11
 7-3 Electronics Module Removal and Installation..... 7-12
 7-4 Measuring Cell Alignment and Insertion Depth..... 7-15

8-1 Transmitter Block Diagram..... 8-1
 8-2 Pressure Measuring Cell..... 8-2
 8-3 Differential Pressure and Flow Measuring Cell..... 8-3
 8-4 Flanged Level Measuring Cell..... 8-4
 8-5 Absolute Pressure Measuring Cell, Differential Construction..... 8-4
 8-6 Absolute Pressure Measuring Cell, Gauge Construction..... 8-5

9-1 Dimensions, Gauge Construction, Pressure and Absolute Models..... 9-31
 9-2 Dimensions, Differential Construction, Differential, Flow, and Absolute Pressure Models..... 9-32
 9-3 Dimensions, Differential Pressure and Flow Models with H03 Option..... 9-33
 9-4 Dimensions, Flange Level Models..... 9-34
 9-5 Declaration of Conformity..... 9-38
 9-6 Certificate of NACE Compliance..... 9-39

A-1 Online Configuration Map..... A-2

B-1 Control Drawing for Sitrans P DSIII Transmitter..... B-2

C-1 Elevated Span Example..... C-1
 C-2 Suppressed Span Example..... C-1
 C-3 Elevation Calculation Example..... C-2
 C-4 Suppression Calculation Example..... C-2

LIST OF TABLES

TABLE AND TITLE	PAGE
1-1 Measurement and Model vs. Figure References.....	1-2
1-2 Contact Information.....	1-11
2-1 Function Keys with Their Labels and Actions Performed.....	2-5
2-2 Communicator Firmware Device Descriptions, Rev. F2.2.....	2-10
2-3 Offline Menu Map Continued, “Edit Individually” Options.....	2-12
4-1 Operating Mode and Network.....	4-10

4-2 Flange and Extension Dimensions..... 4-25

6-1 Operating Mode and Status Arrows 6-2

6-2 Parameters Accessible Using the Magnetic Pushbuttons 6-6

6-3 Pushbutton and Function Disable Options 6-14

6-4 Pushbutton and Function Disable Options 6-24

9-1 Model 7MF4033, Model Designation 9-2

9-2 Model 7MF4233, Model Designation 9-4

9-3 Model 7MF4333, Model Designation 9-6

9-4 Model 7MF4433, Model Designation 9-8

9-5 Model 7MF4533, Model Designation 9-10

9-6 Model 7MF4633 and 7MF4912, Model Designation 9-12

9-7 Measuring Cells for Pressure, Service Parts 9-15

9-8 Measuring Cells for Absolute Pressure, Gauge Construction, Service Parts 9-15

9-9 Measuring Cells for Absolute Pressure, Differential Construction, Service Parts 9-16

9-10 Measuring Cells for Pressure and Flow, Differential Construction, Service Parts 9-17

9-11 Measuring Cells for Differential Pressure and Flow, Service Parts 9-18

9-12 Measuring Cell for Filling Level, Service Parts 9-19

9-13 Electronics and Connecting Boards, Service Parts 9-19

9-14 Accessories 9-20

9-15 Specifications, Pressure and Differential Pressure Models 9-21

9-16 Specifications, Absolute Pressure and Filling Level Models 9-25

9-17 Pressure Transmitter, Model 7MF4033 9-29

9-18 Differential Pressure and Flow Transmitters, 7MF4433 & 7MF4533 9-29

9-19 Absolute Pressure, Gauge Construction, 7MF4233 9-29

9-20 Absolute Pressure, Differential Construction, 7MF4333 9-30

9-21 Flanged Level, 7MF4633/7MF4912 9-30

Changes for Revision 4, September 2004

Significant changes for Rev. 4 are indicated by change bars in the page margins. Some are listed below.

Section	Revision
Cover	Manual revision number and date changed.
Appendix B	Control drawings updated.

SITRANS P, Series DS III, and Procidia are Siemens Energy & Automation, Inc. trademarks. All other trademarks are the property of their respective owners.

Siemens Energy & Automation, Inc. assumes no liability for errors or omissions in this document or for the application and use of information included in this document. The information herein is subject to change without notice.







Procedures in this document have been reviewed for compliance with applicable approval agency requirements and are considered sound practice. Neither Siemens Energy & Automation, Inc. nor these agencies is responsible for repairs made by the user.



Conventions, Symbols, and General Information

Conventions and Symbols

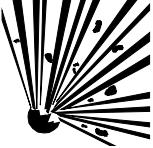
The following symbols may be used in this manual and may appear on the equipment. The reader should become familiar with the symbols and their meaning. Symbols are provided to quickly alert the reader to safety related text.

Symbol	Meaning
 DANGER	Indicates an immediate hazardous situation which, if not avoided, <i>will</i> result in death or serious injury.
 WARNING	Indicates a potentially hazardous situation which, if not avoided, <i>could</i> result in death or serious injury.
 CAUTION	Indicates a potentially hazardous situation which, if not avoided, <i>may</i> result in minor or moderate injury.
CAUTION	Indicates a potentially hazardous situation which, if not avoided, may result in property damage.
NOTICE	Indicates a potential situation which, if not avoided, may result in an undesirable result or state.
Important	Identifies an action that should be taken to avoid an undesirable result or state.
Note	Identifies additional information that should be read.
	Electrical shock hazard. The included Warning text states that the danger of electrical shock is present.
	Electrical shock hazard. Indicated that the danger of electrical shock is present.
	Explosion hazard. Indicates that the danger of an explosion hazard exists.
	Electrostatic discharge. The presence of this symbol indicates that electrostatic discharge can damage the electronic assembly.

Qualified Persons

The described equipment should be installed, configured, operated, and serviced only by qualified persons thoroughly familiar with this User's Manual. A copy of this manual accompanies the equipment. The current version of the manual, in Portable Document Format (PDF), can be downloaded from www.sea.siemens.com/ia/.

For the purpose of this manual and product labels, a qualified person is one who is familiar with the installation, assembly, commissioning, and operation of the product, and who has the appropriate qualifications for their activities such as:

- Training, instruction, or authorization to operate and maintain devices/systems according to the safety standards for electrical circuits, high pressures, and corrosive, as well as, critical media.
- For devices with explosion protection: training, instruction or authorization to work on electrical circuits for systems that could cause explosions.
- Training or instruction according to the safety standards in the care and use of suitable safety equipment.

Scope

This manual does not purport to cover all details or variations in equipment, nor to provide for every possible contingency to be met in connection with installation, operation, or maintenance. Should further information be desired or should particular problems arise which are not covered sufficiently for the purchaser's purposes, the matter should be referred to one of the support groups listed in the Product Support section of this manual.

The contents of this manual shall not become part of or modify any prior or existing agreement, commitment or relationship. The sales contract contains the entire obligation of Siemens. The warranty contained in the contract between the parties is the sole warranty of Siemens. Any statements continued herein do not create new warranties or modify the existing warranty.

General Warnings and Cautions



An explosion-proof device may be opened only after power is removed from the device.

An intrinsically safe device loses its license as soon as it is operated in a circuit that does not meet the requirements of the examination certificate valid in your country.

The device may be operated with high pressure and corrosive media. Therefore, serious injury and/or considerable material damage cannot be ruled out in the event of handling of the device.

The perfect and safe operation of the equipment is conditional upon proper transport, proper storage, installation and assembly, as well as, on careful operation and commissioning.

The equipment may be used only for the purposes specified in this User's Manual.

CAUTION

Electrostatic discharge can damage or cause the failure of semiconductor devices such as integrated circuits and transistors. The symbol at right appears on a circuit board or other electronic assembly to indicate that special handling precautions are needed.



- A properly grounded conductive wrist strap must be worn whenever an electronics module or circuit board is handled or touched. A service kit with a wrist strap and static dissipative mat is available from Siemens (PN15545-110). Equivalent kits are available from both mail order and local electronic supply companies.
- Electronic assemblies must be stored in static protective bags when not installed in equipment.



1.0 INTRODUCTION

This user's manual is for the Siemens Energy & Automation SITRANS P Series DSIII Pressure Transmitters.

All information needed to bench test, install, configure, calibrate, and service a transmitter is included in this user's manual.

IMPORTANT

Save this user's manual. It should be available to those installing, configuring, operating, and servicing the described pressure transmitters.

1.1 CONTENTS

The user's manual consists of a table of contents, ten sections, and three appendices. Following the table of contents is a subsection that contains important information about the symbols that can appear in this user's manual and on the transmitter. The subsection also has statements about installing and servicing the transmitter. A brief description of each major section and appendices follows.

Section 1, Introduction, describes each section in the manual and provides a brief description of the SITRANS P Series DSIII Pressure Transmitter line. A product support section has telephone, fax, E-mail, and Internet contact information.

Section 2, Model 275 Universal HART Communicator, describes use of the HART Communicator to test, configure, and calibrate a transmitter.

Section 3, Pre-Installation Test, provides procedures to perform a bench test of the transmitter to ensure proper operation of all transmitter functions. Start-up configuration is described here.

Section 4, Installation, furnishes specific information for mechanical and electrical installation of the transmitter.

Section 5, Post-Installation Test, describes how to confirm that the transmitter has been installed correctly - sometimes referred to as commissioning.

Section 6, On-Line Configuration and Operation, details local configuration using the magnetic pushbuttons and remote configuration using the HART Communicator. Local operation and remote operation of the transmitter are described.

Section 7, Calibration and Maintenance, provides references to calibration procedures for analog and digital modes and to a zeroing procedure for mounting position. It also furnishes preventive maintenance, troubleshooting, and assembly replacement procedures.

Section 8, Circuit Description, contains an assembly-level circuit description to support transmitter servicing.

Section 9, Model Designations and Specifications, has tables that correlate rating plate model numbers to transmitter physical configurations. This section also contains an accessory list and several service parts lists. Detailed mechanical, functional, performance, and environmental specifications are provided, as are dimension drawings of the transmitter. Hazardous area certifications are listed.

Section 10, Glossary, contains definitions of various transmitter-related terms.

Appendix A, Online Configuration Map, is used to help navigate HART/transmitter menus during remote configuration and operation of the transmitter.

Appendix B, Hazardous Area Installations, contains control drawings and other information needed for installation in a hazardous area.

Appendix C, Elevation and Suppression Corrections, explains how to perform elevation and suppression calculations necessary for certain liquid level gauging applications.

Warranty contains the product warranty statements and information concerning servicing of the product during the warranty period.

1.2 PRODUCT DESCRIPTION

SITRANS P Series DSIII transmitters provide reliable, accurate, stable, and cost-effective measurement of differential, absolute, and gauge pressure and liquid level.

The transmitter is a microcontroller-based, self-contained pressure-to-current transducer. A measuring cell senses the applied process pressure and provides an analog output signal that is proportional to applied pressure. An analog-to-digital converter produces a digital signal for the microcontroller. The microcontroller modifies and corrects the signal for linearity and temperature, and a digital-to-analog converter produces a 4-20 milliamper output signal for the loop.

The transmitter can be installed quickly and easily using one of the optional mounting brackets. Illustrations showing mounting hardware and dimensions are provided in this manual. Measuring cell construction determines a transmitter's physical dimensions and mechanical installation. Note that a given sensor construction can involve one or more measurement methods, as shown in Table 1-1.

TABLE 1-1 Measurements, Models and Figure References

Measurement	Model And Measuring Cell Construction	Refer To
Absolute or Gauge Pressure	7MF4033, Gauge Construction 7MF4233, Gauge Construction 7MF4333, Differential Construction	Figures 1-1, 4-3, 4-4, 4-10, 4-12, 9-1 and 9-2
Differential Pressure	7MF4433, Differential Construction 7MF4533, Differential Construction	Figures 1-2, 1-3, 4-1, 4-2, 4-11, 4-12, 9-2, and 9-3
Liquid Level (Flange)	7MF4633, Flange Construction 7MF4912, Flange	Figures 1-4, 4-5, and 9-4

Figures 1-1 through 1-4 show the various transmitter models and constructions. They also show common transmitter mounting methods. The mounting brackets shown are optional.

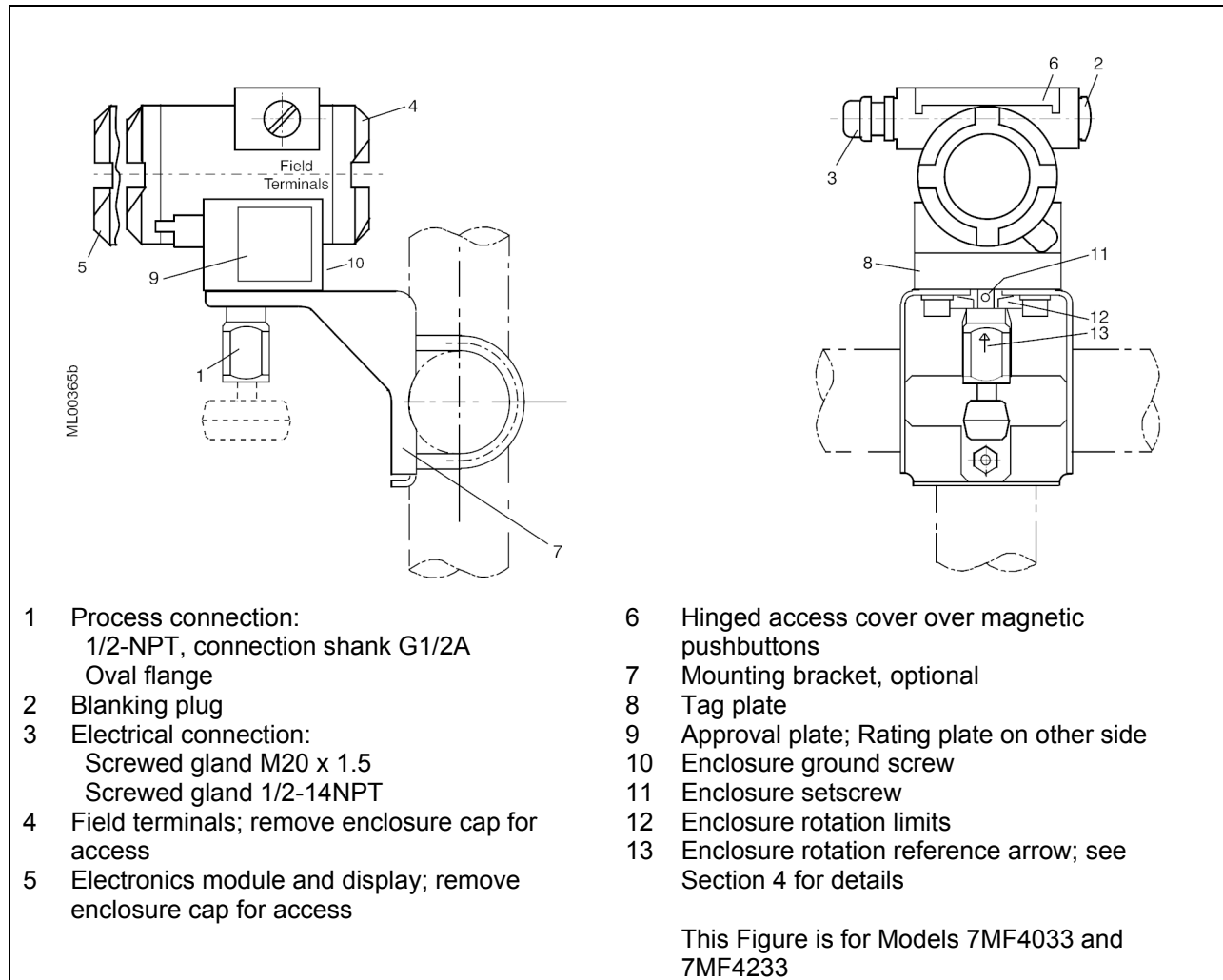

FIGURE 1-1 Gauge Construction, Pressure and Absolute Pressure Models

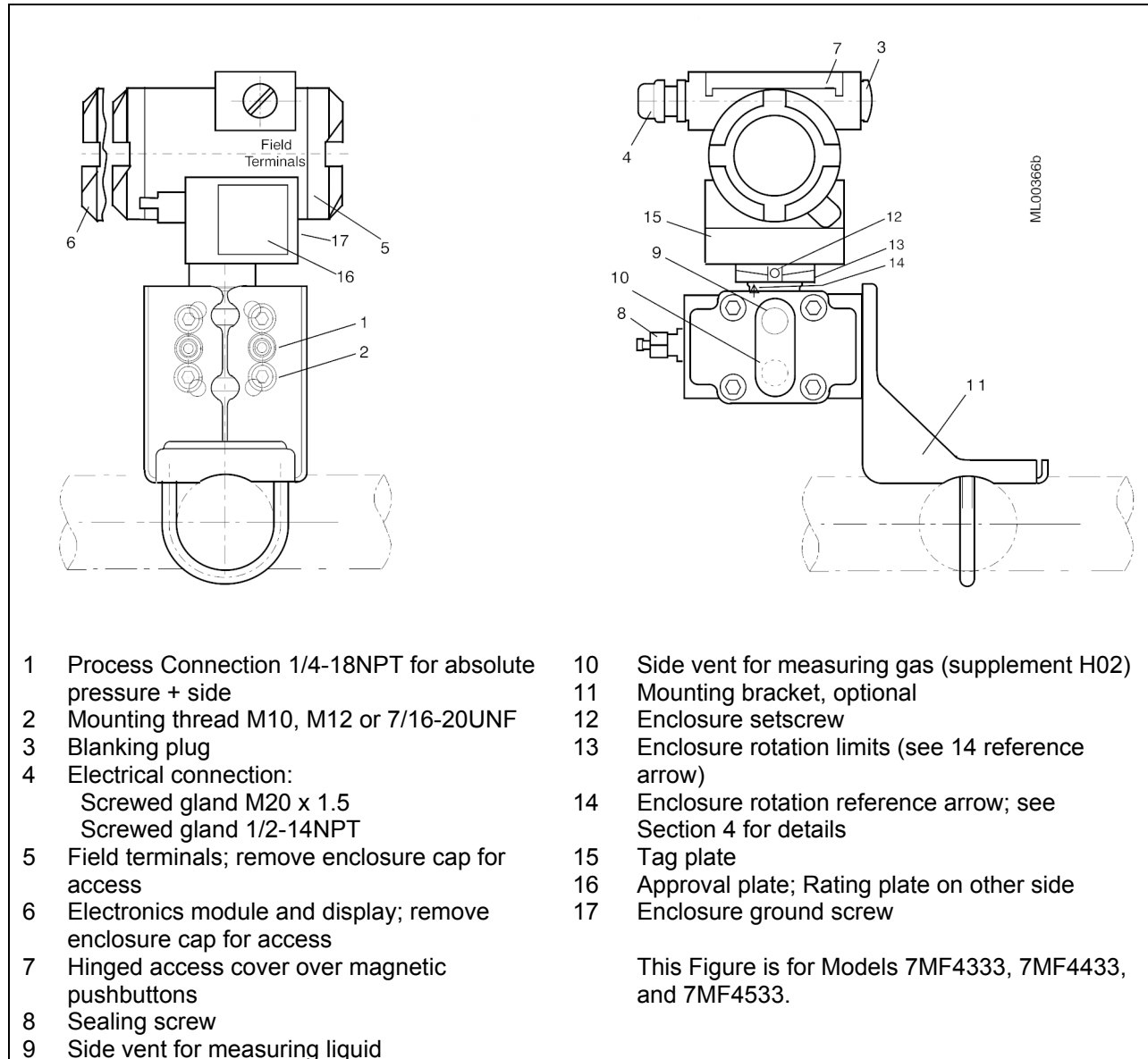

FIGURE 1-2 Differential Construction; Differential, Flow, and Absolute Models

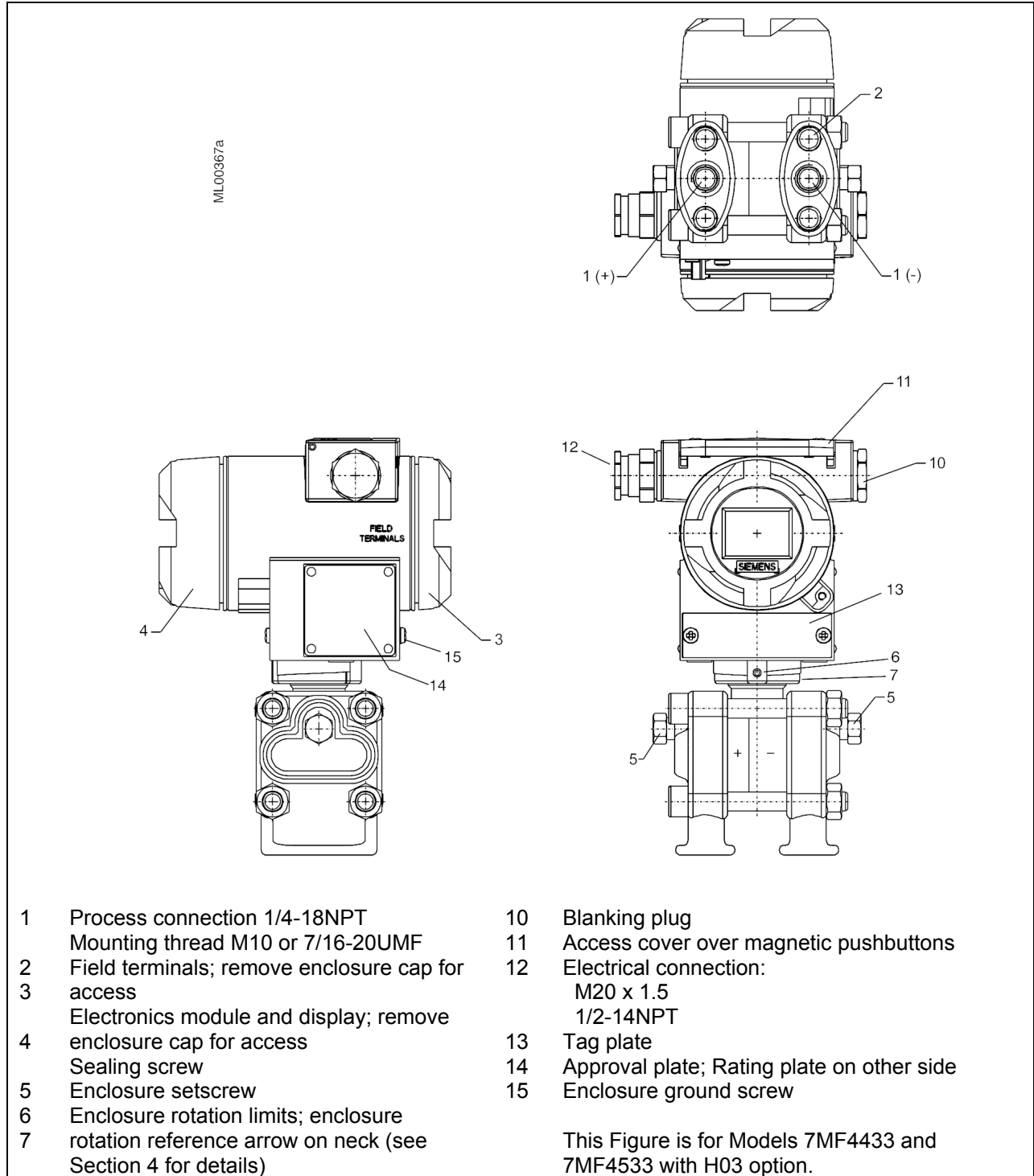

FIGURE 1-3 Differential Pressure and Flow Models with H03 Option

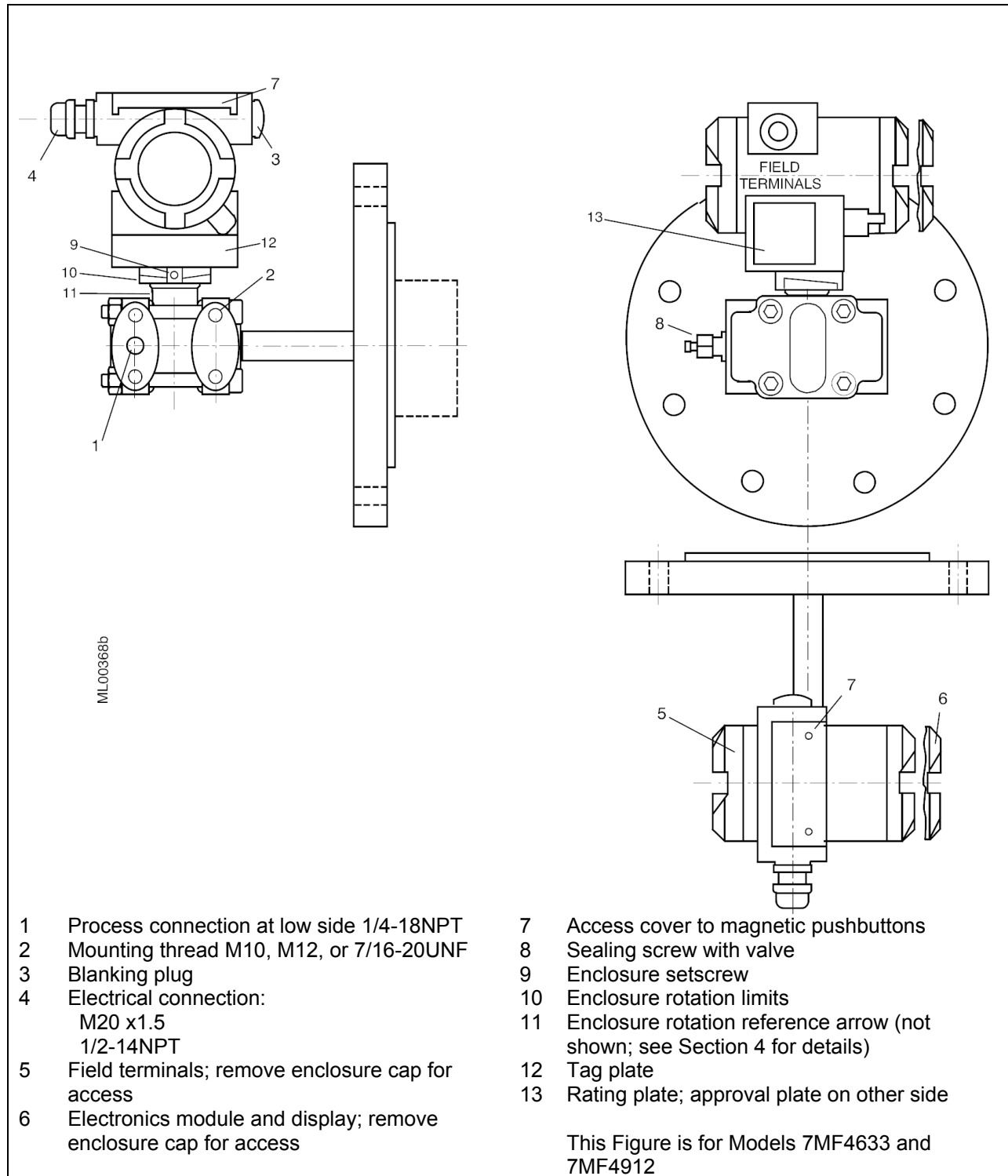

FIGURE 1-4 Flanged Liquid Level Models

A transmitter can operate in either analog mode or digital mode, as discussed in the following paragraphs.

Analog Mode

A single transmitter is connected to a controller, recorder, or other field device. A loop known as a Point-to-Point network interconnects the instruments. Figure 1-5 shows a traditional application.

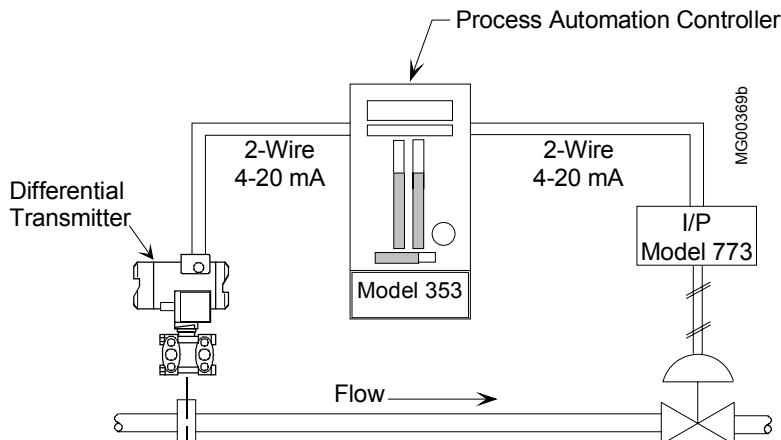

FIGURE 1-5 Traditional Application

The HART[®] (Highway Addressable Remote Transducer) protocol is used for communication between the transmitter and a HART Communicator, a personal computer running configuration software, or another remote device. This is done by superimposing the HART digital signal on the analog current. HART communications can be used to transfer a new or edited configuration, remotely monitor the process variable, or service a transmitter.

Digital Mode

Up to 15 transmitters can be parallel connected to a Multi-Drop network using only shielded, twisted-pair cable. The HART protocol provides communication between the transmitters and a HART-compatible controller, recorder, or other device. Each transmitter is identified by a unique network address that is selected during configuration.

Display, Magnetic Pushbuttons, and Loop Connections

The optional display (Figure 1-6) permits local viewing of input and output variables and status messages, and it simplifies local configuration. Local configuration is performed using three magnetic pushbuttons that are found beneath an access cover in the transmitter housing. Section 6 On-Line Configuration and Operation describes use of the display and magnetic pushbuttons.

Loop connections are made to a terminal assembly with three screw terminals (Figure 1-7). The assembly is located within the transmitter enclosure and is accessed by removing the enclosure cap adjacent to FIELD TERMINALS on the enclosure. The terminal assembly also has terminals to connect an external digital milliammeter for loop troubleshooting and transmitter calibration. Loop wiring is shown in Section 4 Installation.

An enclosure ground connection is located on the housing beneath the field terminal enclosure cap. The enclosure should always be grounded by a wire connected from this terminal to an earth ground, even when a ground may be provided by metal conduit protecting the loop wiring.

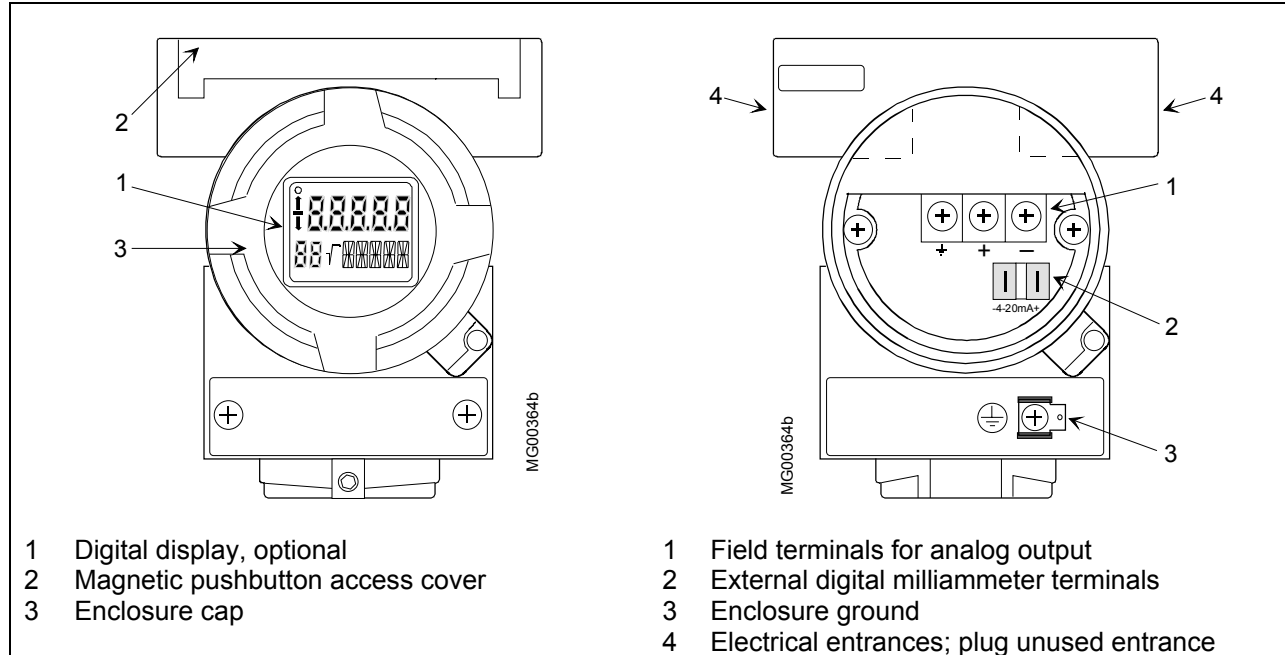
**FIGURE 1-6 Display****FIGURE 1-7 Field Terminals**

Transmitters have an intrinsically safe, explosion proof, NEMA 4x (IP67/68), field mountable, hardened enclosure. Electrical conduit connections are 1/2-14 NPT or M20 x 1.5. All process wetted materials are 316 stainless steel or better. The flush-mount process connection of the liquid level model is compatible with standard ANSI and metric flange sizes for tanks and pipes.

1.3 RATING, APPROVAL, AND TAG PLATES

These plates are fastened to the outside of the transmitter enclosure, as shown at right. The rating plate shows that transmitter’s model number, serial number, and performance data. The approval plate shows that transmitter’s approval and certification data. Always refer to these plates to confirm the model number, performance data and approval and certification data before installing or servicing a transmitter. Representative plates are shown below.

The tag plate is fastened with two screws so it can be removed for engraving.

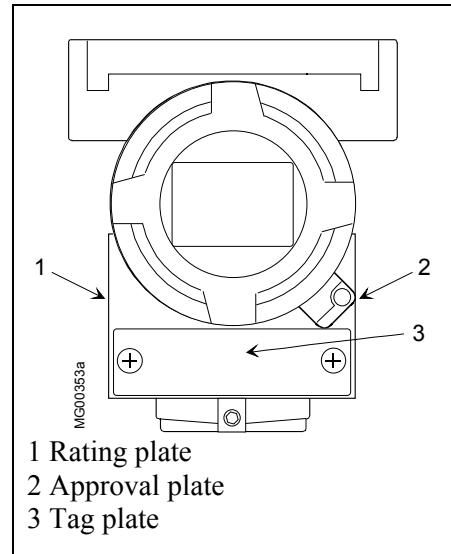

<div style="text-align: center;"> <p>SIEMENS D-76181 Karlsruhe</p> </div> <div style="border: 1px solid black; padding: 5px;"> <p>SITRANS P CE</p> <p>Transmitter for diff. pressure</p> <p>7MF4433-1DA20-1HC6-Z ————— 1</p> <p>A01+B11+Y01 ————— 2</p> <p>Feb. Nr. N1-M831-9292402</p> <p>VH :DC 10.5-45V (not intr. safe) out.: 4-20 mA</p> <p>Mat.: Connec. Diaphr. O-ring Filling 1.4408 1.4404 FPM Siliconoil</p> <p>Measuring span : 2.5 - 250 mbar</p> <p>Rated pressure : PN 160</p> <p>Type of protection IP 65</p> <p>Made in USA</p> </div> <div style="text-align: right; font-size: small; margin-top: 5px;">MG00384a</div> <p style="text-align: center;">Rating Plate</p>	<div style="text-align: center;"> <p>SIEMENS D-76181 Karlsruhe</p> </div> <div style="border: 1px solid black; padding: 5px;"> <p>SITRANS P</p> <p>(XP/DIP) or (IS)</p> <p>CL I ZN 0/1 AEX ia IIC T4..T6 FM</p> <p>CL I,II,II DIV 1 ABCKEFB T4..T6 APPROVED</p> <p>Per Control Dwg. A5E00072770A</p> <p>$V_i < 30V$: $I_i < 100 mA$: $P_i < 0.75 W$</p> <p>$C_i < 6 nF$: $L_i < 0.4 mH$</p> <p>(NI) CL 1 DIV 2 ABCD T4..T6</p> <p>CL II DIV 2 GP FB, CL III</p> <p>Vmax = 30 V</p> <p>Ta - T4: -40..85°C ; T6: -40..60°C</p> <p>ENCL Type 4X</p> <p>FW: 11.02.03 HW: 02.05.01</p> </div> <div style="text-align: right; font-size: small; margin-top: 5px;">MG00384a</div> <p style="text-align: center;">Approval Plate</p>
--	--

1 Model number
2 Serial number

1.4 CONFIGURATION

A transmitter must be configured before use. Each transmitter is shipped with either a default configuration or, if specified at time of order, a custom configuration defined by the user. The default configuration may need to be edited before the transmitter is used in a loop. The configuration is stored within the transmitter in a non-volatile memory.

A configuration can be created or edited locally at the transmitter’s magnetic pushbuttons or remotely using the Model 275 HART Communicator.

Note: If using a Model 375 Field Communicator, see the inside of the front cover of this manual.

1.5 PRODUCT SUPPORT

This section provides the Internet site addresses, e-mail addresses, telephone numbers, and related information for customers to access Siemens product support.



When contacting Siemens for support:

- Please have complete product information at hand:
 - For hardware, this information is provided on the product nameplate (part number or model number, serial number, and/or version).
 - For most software, this information is given in the Help > About screen.
- If there is a problem with product operation:
 - Is the problem intermittent or repeatable? What symptoms have been observed?
 - What steps, configuration changes, loop modifications, etc. were performed before the problem occurred?
 - What status messages, error messages, or LED indications are displayed?
 - What troubleshooting steps have been performed?
 - Is the installation environment (e.g. temperature, humidity) within the product's specified operating parameters? For software, does the PC meet or exceed the minimum requirements (e.g. processor, memory, operating system)?
- A copy of the product Service Instruction, User's Manual, or other technical literature should be at hand. The Siemens public Internet site (see the table) has current revisions of technical literature, in Portable Document Format, for downloading.
- To send an instrument to Siemens for repair, request a Return Material Authorization (RMA).

IMPORTANT

An instrument must be thoroughly cleaned (decontaminated) to remove any process materials, hazardous materials, or blood born pathogens prior to return for repair. Read and complete the Siemens RMA form(s).

TABLE 1.1 Contact Information

NORTH AMERICA	Telephone	+1 800 569 2132, option 2 for Siemens-Moore brand instruments
	Fax	+1 215 283 6358
	E-mail	PITechSupp@sea.siemens.com
	Hours of Operation	8 a.m. to 6 p.m. eastern time Monday – Friday (except holidays)
	Public Internet Site	www.sea.siemens.com/ia/
	Repair Service	+1 215 646 7400 extension 4993

For contact information outside North America, visit the Siemens public Internet site (see the table), locate Customer Support, and click on Siemens & Moore Brand Instrumentation. ■

2.0 MODEL 275 UNIVERSAL HART COMMUNICATOR

The Model 275 Universal HART Communicator is a handheld interface that provides a common communication link to SITRANS P transmitters and other HART-compatible instruments.

This section describes HART Communicator connections, liquid crystal display, keypad, and on-line and off-line menus. It also provides overviews of many Communicator functions. The Communicator is shown in Figure 2-1. For information about the Communicator's battery pack, Memory Module, Data Pack, and maintenance procedures, refer to the manual supplied with the Communicator.

2.1 INTRODUCTION

The HART Communicator connects to and communicates with a transmitter or other HART device using a 4-20 mA loop, provided a minimum load resistance of 250 Ω is present between the Communicator and the power supply. The Communicator uses Bell 202 frequency-shift keying (FSK) to impose high-frequency digital signals on a standard 4-20 mA current loop. Because no net energy is added to the loop, HART communication does not disturb the 4-20 mA signal.

The Communicator can be used in hazardous and non-hazardous locations.

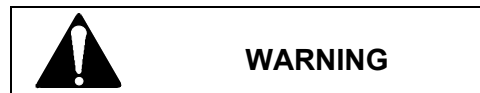

Explosion can cause death or serious injury.

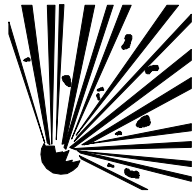

Before connecting the HART Communicator in an explosive atmosphere, be sure that the instruments in the loop are installed in accordance with intrinsically safe or non-incendive field wiring practices.

Refer to the Communicator nameplate and the supplied manual for certifications and approvals before connecting, or making a connection to the serial port or NiCad charger port on the Communicator.

2.2 COMMUNICATOR CONNECTIONS

The Communicator can interface with a transmitter from the control room, the instrument site, or any wiring termination point in the loop. Connections are made through a supplied 40" (1m) cable (dual banana plug to mini-hook test clips). The connection panel also may have a jack for the optional NiCad charger, and it has a serial port for a future connection to a personal computer (PC).

To interface with a transmitter or other HART device, connect the HART Communicator in parallel with the instrument or load resistor. The connections are non-polar. For intrinsically safe FM and CSA wiring connections, see the manual supplied with the Communicator.

Figure 2-2 illustrates typical wiring connections between the HART Communicator and a loop with a transmitter or other HART-compatible device in a loop. The Communicator is quickly connected into a transmitter loop.

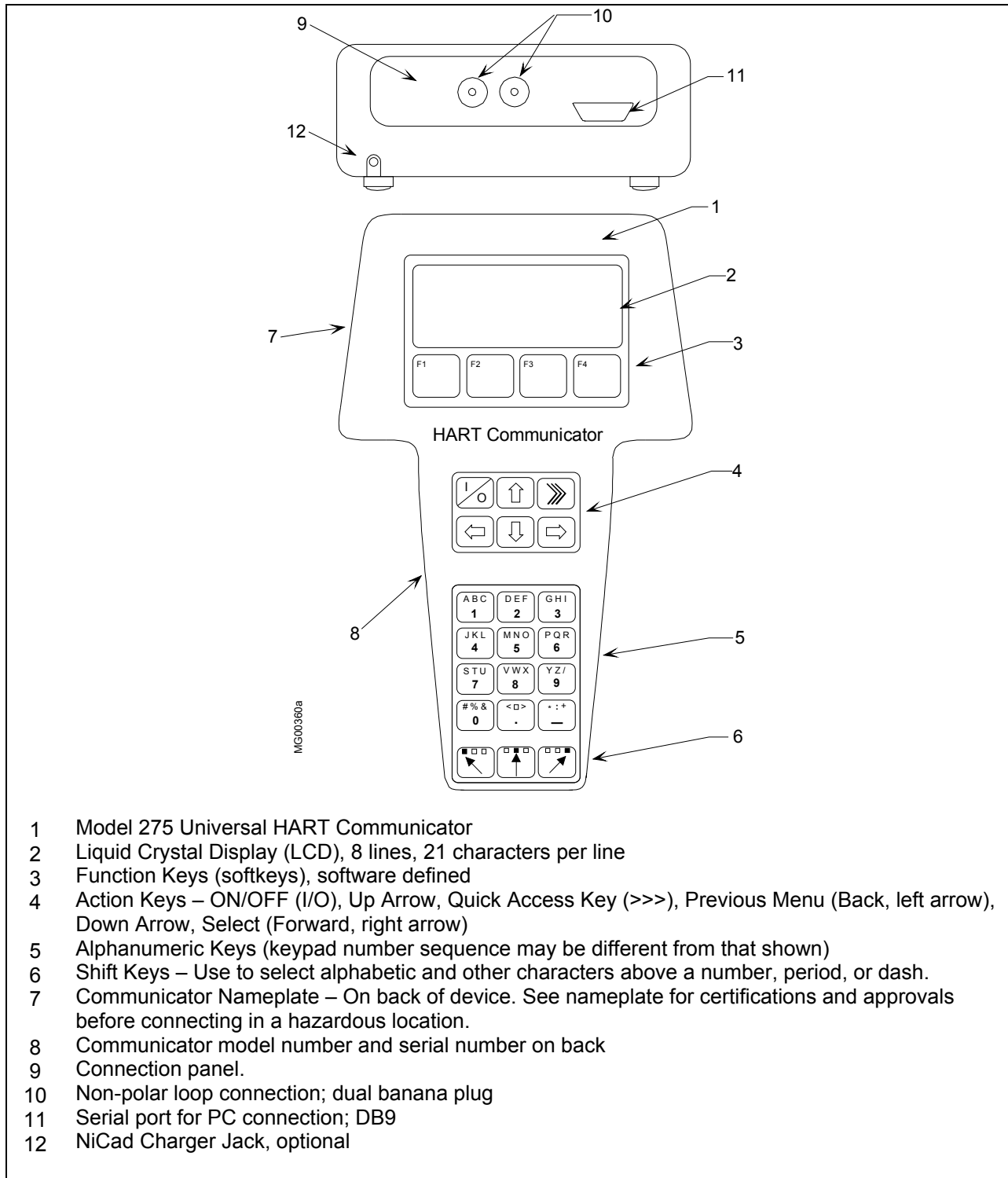

FIGURE 2-1 Model 275 Universal HART Communicator

Note: If using a Model 375 Field Communicator, see the inside of the front cover of this manual.

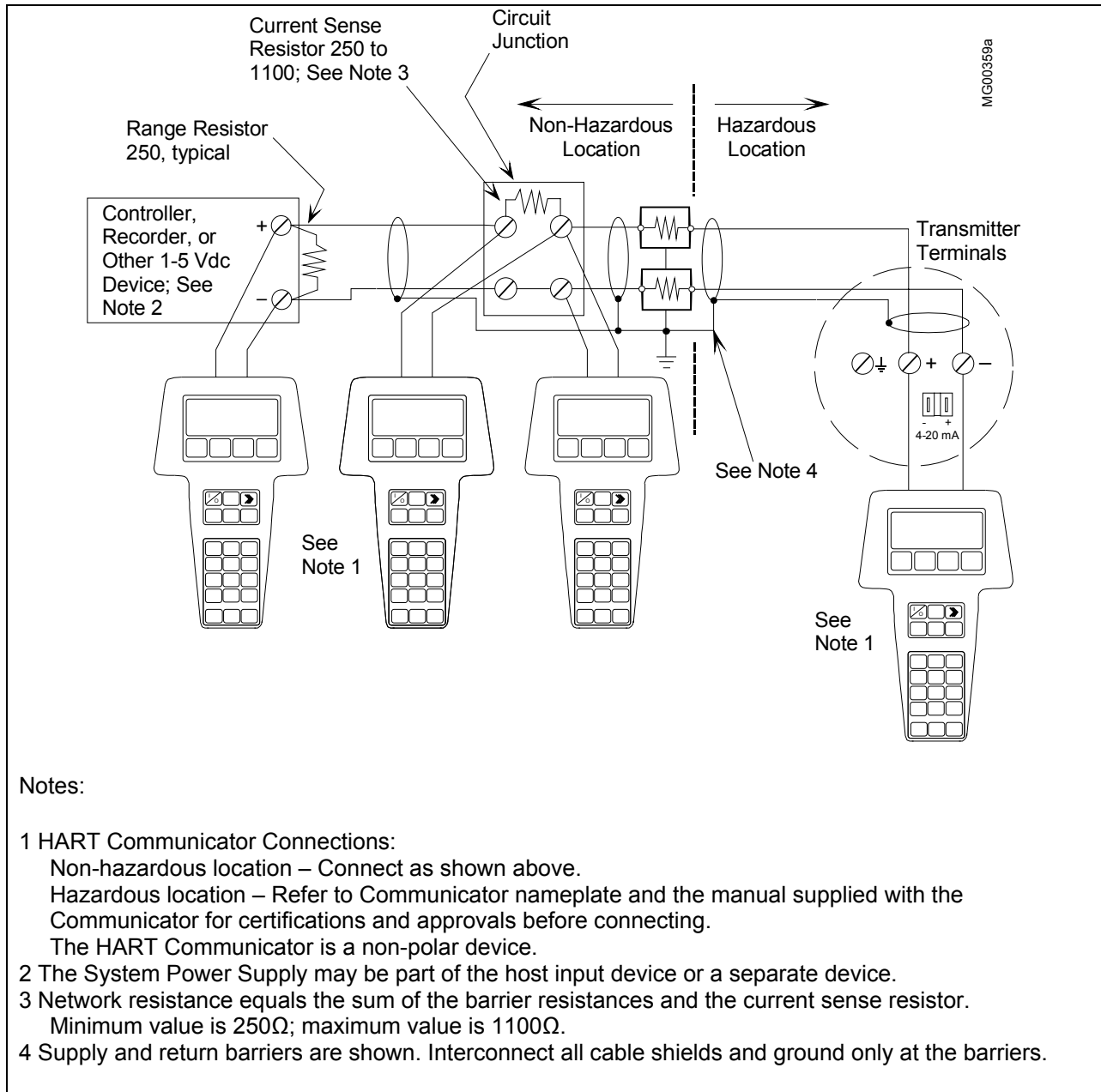

FIGURE 2-2 HART Communicator Connections to a Transmitter Loop

2.3 CONTROLS OVERVIEW

As shown in Figure 2-1, the front of the HART Communicator has five major functional areas: liquid crystal display (LCD), function keys, action keys, alphanumeric keys, and shift keys. The next five sections describe how each of these functional areas is used to enter commands and display data.

2.3.1 Liquid Crystal Display

The liquid crystal display (LCD) is an 8-line by 21-character display that provides communication between the user and a connected device. When the HART Communicator is connected to a SITRANS P transmitter or other HART-compatible device, the top line of the Online menu displays the model name of the device and its tag. A typical display is shown below. The actual display content can vary with the device type and manufacturer.

```

SITRANS P
Online ←
1->Pres
2 Type
3 Device setup

HELP | SAVE

```

Note: If using a Model 375 Field Communicator, see the inside of the front cover of this manual.

The bottom line of each menu is reserved for dynamic labels for the software-defined function keys, F1-F4, which are found directly below the display. More information on software-defined function keys is given in the next section.

2.3.2 Software-Defined Function Keys

The four software-defined function keys (softkeys), located below the LCD and marked F1 through F4, are used to perform software functions as indicated by the dynamic labels. Pressing the function key immediately beneath a label activates the displayed function.

The label appearing above a function key indicates the function of that key for the current menu. For example, in menus providing access to on-line help, the HELP label appears above the F1 key. In menus providing access to the Online menu, the HOME label appears above the F3 key. Table 2-1 lists these labels and describes what happens when each function key is pressed.

TABLE 2-1 Function Keys with Their Labels and Actions Performed

F1	F2	F3	F4
HELP Access on-line help	ON/OFF Activate or deactivate a bit-enumerated binary variable	ABORT Terminate current task	OK Acknowledge information on the LCD
RETRY Try to reestablish communication	DEL Delete current character or Quick Access Key menu item	ESC Leave a value unchanged	ENTER Accept user-entered data
EXIT Leave the current menu	SEND Send configuration data to device	QUIT Terminate session because of a communication error	EXIT Leave the current menu
YES Answer to yes/no question	PGUP Move up one help screen	PGDN Move down one help screen	NO Answer to yes/no question
ALL Include current Quick Access Key item on Quick Access Key menu for all devices	PREV Go to previous message in a list of messages	NEXT Go to next message in a list of messages	ONE Include Quick Access Key item for one device
NEXT Go to the next variable in off-line edit	SAVE Save information to Communicator	HOME Go the top menu in the device description	
FILTR Open customization menu to sort configurations	MARK Toggle marked variable in configuration to be sent to a field device	BACK Go back to the menu from which HOME was pressed	
	XPAND Opens detailed configuration information	EDIT Edit a variable value	
	CMPRS Closes detailed configuration information	ADD Add current item to Quick Access Key menu	

2.3.3 Action Keys

Directly beneath the LCD and software-defined function keys are six blue, white, and black action keys. Each has a specific function as described below:

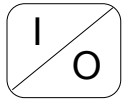

ON/OFF KEY – Use to power-up the Communicator. When the Communicator is turned on, it automatically searches for a HART-compatible device on the 4-20 mA loop. If no device is found, the Communicator displays the Main menu:

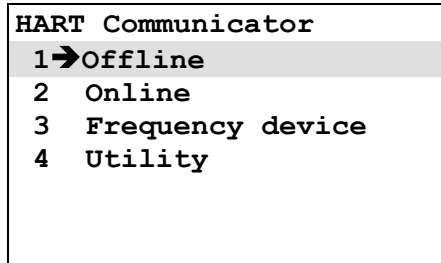

If a SITRANS P transmitter is found, the Communicator displays the Online menu:

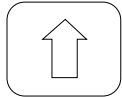
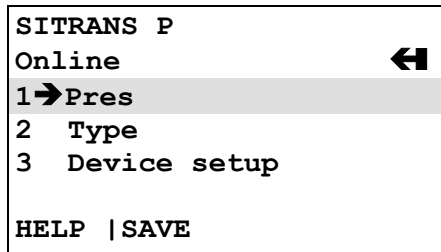

UP ARROW KEY – Use to move the cursor up through a menu or list of options or to scroll through lists of available characters when editing fields that accept both alpha and numeric data.

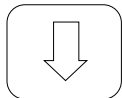

DOWN ARROW KEY – Use to move the cursor through a menu or a list of options or to scroll through lists of available characters when editing fields that accept alpha and numeric data.

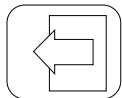

LEFT ARROW/PREVIOUS MENU KEY – Use to move the cursor to the left or back to the previous menu.

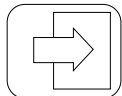

RIGHT ARROW/SELECT KEY – Use to move the cursor to the right or to select a menu option.



QUICK ACCESS KEY (HOT KEY) – When the Communicator is on and connected to a HART-compatible device, pressing the Quick Access Key instantly displays the Quick Access Key menu of user-defined options. When the Communicator is off and the Quick Access Key is pressed, the Communicator automatically powers-up and displays the Quick Access Key menu.

See Section 2.6 for more information on using the Quick Access Key.

Important

When performing certain operations, the message “OFF KEY DISABLED” indicates that the Communicator cannot be turned off. This feature helps prevent accidental shutoff of the Communicator while the output of a device is fixed or a device variable is being edited.

2.3.4 Alphanumeric and Shift Keys

The alphanumeric keys perform two functions: (1) rapid selection of menu options and (2) data entry. The shift keys located below the alphanumeric keys on the keypad are used during data entry to select from among the characters available above each number.

2.3.4.1 Rapid Selection of Menu Options

From any menu, use the keypad to select available options in two ways. First, use the UP or DOWN arrow keys, followed by the RIGHT ARROW/SELECT key, to access available options displayed on the LCD.

As an alternative, use the rapid select feature. Simply press the number on the alphanumeric keypad that corresponds to the desired menu option. For example, to quickly access the Utility menu from the Main menu, simply press “4” on the keypad.

2.3.4.2 Data Entry

Some menus require data entry. Use the alphanumeric and shift keys to enter all alphanumeric information into the HART Communicator. Pressing an alphanumeric key alone while editing causes the large character in the center of the key (number 0-9, decimal point, or dash) to be entered.

Pressing and releasing a shift key activates shift and causes the appropriate arrow icon (↵, ↑, or ↶) to appear in the upper right-hand corner of the LCD. When shift is activated, the indicated alpha characters or symbols are entered when the keypad is used.

Example

To enter a number, such as “7,” simply press the number key.

To enter one of the small characters appearing above the large numeral (i.e., a letter, space, or mathematical symbol), first press and release the corresponding shift key at the bottom of the keypad, then press the desired alphanumeric key. To enter the letter “E,” press and release the middle shift key, then press the number “2” key.

To deactivate a shift key without entering a letter, space, or mathematical symbol, simply press that shift key again.

2.4 GETTING TO KNOW THE COMMUNICATOR

The HART Communicator operates either on-line or off-line. Off-line operation is used to create or edit a configuration that can then be downloaded to a HART device, such as a transmitter. On-line operation is used to download a configuration to a HART device, upload a configuration, edit HART device operating parameters, and monitor process values.

For off-line operation, the Communicator need not be connected to a HART device. On-line operation requires a connection to a powered HART device.

The menu that appears first when the Communicator is turned on depends on whether the Communicator is connected to a powered HART device.

- Communicator not connected - Main menu (off-line operation)
- Communicator connected - Online menu (on-line operation)

To work off-line when connected to a powered loop, access the Main menu from the Online menu by pressing the LEFT ARROW/PREVIOUS MENU key.

Note

Communicator internal operation is controlled by firmware. Consequently, operation will depend upon the firmware version and the installed device drivers, as discussed in this section.

2.4.1 Display Icons

Several different symbols (icons) appear on the LCD to show the state of the Communicator and provide visible response to actions of the user. Figure 2-3 shows the display icons and how they relate to keypad functions.

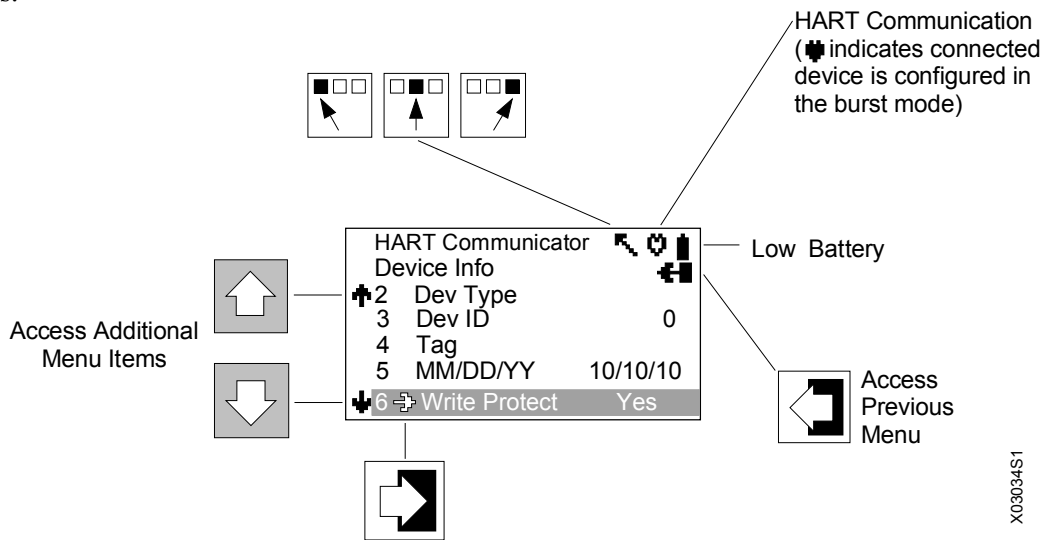

FIGURE 2-3 HART Communicator Display Icons

2.4.2 Menu Structure

The HART Communicator uses a hierarchical menu structure. That is, high-level menus are accessed first, and they provide access to lower-level menus. This structure groups related functions together and minimizes the number of options displayed at once.

To become familiar with the menu structure, perform the following actions:

1. With the Communicator off-line (not attached to any devices), press the ON/OFF key to turn the Communicator on. The Communicator will perform a self-test routine and display the firmware revision level installed in the Communicator. It will then display a “Polling?” query. Press NO (F4) to go to the Main menu.
2. The cursor (➔) will be positioned at “1 Offline” on the Main menu. Access the Utility menu by pressing the DOWN arrow key three times, then pressing the RIGHT ARROW/SELECT key. The display changes to show the Utility menu.
3. Access the Configure Communicator menu from the Utility menu by pressing the RIGHT ARROW/SELECT key. The display changes to show the Configure Communicator menu.
4. Access the Contrast menu by pressing the DOWN arrow once, then pressing the RIGHT ARROW/SELECT key. The display shows a message explaining how to adjust the LCD contrast.
5. Press ESC (F3) to return to the Configure Communicator menu.
6. Press the LEFT ARROW/PREVIOUS MENU key two times to return to the Main menu.
7. Press the ON/OFF key to turn the Communicator off.

2.4.3 Reviewing Installed Devices

For the HART Communicator to recognize a specific HART-compatible device, it must contain a description for that device. Communicator device descriptions for Moore and Siemens products are listed in Table 2-2. Device descriptions for many other HART-compatible devices from leading manufacturers are included but not listed in the table.

Communicator firmware also contains a “generic” device description, which allows limited access to most HART devices when no device description for that specific product is included.

To review the currently installed device descriptions:

1. Turn on the Communicator (off-line) to display the Main Menu.
2. In the Main menu, press “4 Utility” on the keypad.
3. In the Utility menu, press “5 Simulation” on the keypad. The LCD shows the Manufacturer menu, which contains a list of manufacturers whose device descriptions are installed in the Communicator.
4. Press the DOWN arrow to highlight SIEMENS (or other manufacturer). Press the RIGHT ARROW/SELECT key to reveal the Model menu, which lists the device descriptions currently installed in the Communicator (see Table 2-2).
5. To end the review of devices, press the LEFT ARROW/PREVIOUS MENU key three times.
6. Turn off the Communicator or proceed to the next section.

TABLE 2-2 Communicator Firmware Device Descriptions, Rev. F2.2

MODEL	FIELD DEVICE REVISION	DESCRIPTION	APPROXIMATE VINTAGE¹
(Siemens) Moore Menu²			
760D	Dev V2, DD V1	760D Valve Positioner	---
340A	Dev V1, DD V1	340 Transmitter (pushbutton design)	8/90 - 8/94, Model #s 340__A...
340A Type 6	Dev V1, DD V1	340 Transmitter (pushbutton design)	8/94 - 8/96, Model #s 340__A...
	Dev V2, DD V1	340 Transmitter (magnetic switch design)	Present, Model #s 340__B...
340B	Dev V1, DD V1	340 Transmitter-Controllers (pushbutton design)	8/90 - 8/96, Model #s 340__B...
340S	Dev V1, DD V1	340 Transmitter	---
341 Type 5	Dev V1, DD V1	341 Transmitter	8/94 - Present, Model #s 341...
343	Dev V1, DD V1	343 Temperature Transmitter	---
344	Dev V1, DD V1	344 Transmitter-Controller	8/90 - 8/94 Model #s 344...
	Dev V2, DD V1	344 Transmitter-Controller	8/90 - Present, Model #s 344...
345	Dev V1, DD V1	345 Transmitter-Controller	8/99 - Present
Siemens Menu			
SITRANS P DS3	Dev V2, DD V1	Siemens DS3 Pressure Transmitter	12/00 - Present
Rosemount			
Generic	Dev V5, DD V4	Generic	---

Notes:

¹ Always verify the model and field device revision for the device at hand. For the device model, refer to the Rating Plate (Nameplate). Refer to Appendix A Online Configuration Map to access the “Revision Numbers” menu using the HART Communicator.

² Menu refers to the HART Communicator’s “Manufacturer” screen.

2.5 MAIN MENU

The Main menu is shown at right. To access the Main menu:

Communicator not connected to a HART device – Press the Communicator's ON/OFF key, the first menu to appear after powering up is a "Poll?" query. Since a device is not connected, press NO (F4). The Main menu (at right) will then appear.

Communicator connected to a powered HART device – Press the Communicator's ON/OFF key, the Online menu appears. To access the Main menu, press the LEFT ARROW/PREVIOUS MENU key until the Main menu appears. Alternatively, press HOME (F3) to display the Online menu, followed by the LEFT ARROW/PREVIOUS MENU key to display the Main menu.

HART Communicator	
1->	Offline
2	Online
3	Frequency Device
4	Utility

In the Main menu, access an additional menu by either:

- Moving the cursor to the selection using the UP or DOWN arrow key, followed by pressing the RIGHT ARROW/SELECT key
- Pressing the appropriate number (1-4) on the alphanumeric keypad.

2.5.1 Offline Menu

The Offline menu provides access to two other menus: New Configuration and Saved Configuration. These two configuration menus can be used without connecting to a HART-compatible device, but it is not possible to send saved data to a device if no device is connected.

In the Main menu, press “1 Offline” on the keypad or the RIGHT ARROW/SELECT key to access the Offline menu. The complete menu tree for the Offline Menu is shown in Figure 2-4.

Main Menu 1 Offline	1 New Configuration	1 Moore Products	List of Models	Field Device Revision	From a Blank Template			
		2 Rosemount				1 Mark all		
		3 Siemens				2 Unmark all		
					3 Edit individually >			
					4 Save as...	1 Location		
					2 Name			
					3 Data type			
	2 Save Configuration	1 Module Contents	2 Data Pack Contents	List of Configurations	1 Edit	1 Mark all		
			3 PC				2 Unmark all	
							3 Edit individually >	
			4 Save as...	1 Location				
					2 Name			
			2 Copy to...		3 Data type			
			3 Send					
			4 Print					
			5 Delete					
			6 Rename					
		7 Compare						
2 Online								
3 Frequency Device								
4 Utility								

Note: > = See Table 2-3 for additional menu options

FIGURE 2-4 Offline Menu Map

TABLE 2-3 Offline Menu Map Continued, “Edit individually” Options¹

Tag (type) ²	Alarm URV (type)	Flange type (select)	Extension length (select)
Descriptor (type)	Pres xfer function (select)	Flange material (select)	Electrical connection (select)
Date (type)	Pressure damp (type)	O ring material (select)	Local keys ctrl mod (select)
Pressure unit (select)	AO alarm type (select)	Process flange bolt (select)	Bargraph (select)
Pressure LRV (type)	Alarm LRV (type)	DrainVent / plug mat (select)	Unit tracking (select)
Pressure URV (type)	Alarm URV (type)	DrainVent / plug POS (select)	Local display unit (select)
Pres transfer function (select)	Upper AO limit (type)	RS type (select)	Measuring speed (select)
Pressure damp (type)	Lower AO limit (type)	RS isoltr material (select)	Final assembly num (type)
AO alarm type (select)	Meter type (select)	RS fill fluid (select)	
Alarm LRV (type)	Process connection (select)	Num remote seal (select)	

Notes:

1. Menu sequence is read top to bottom, left to right.
2. (type) = type a value or text; (select) = select from the list offered.

2.5.1.1 New Configuration

This option is used to compile a custom set of device configuration data for downloading later to one or more HART-compatible devices. Downloading the same data to multiple devices ensures that they all store identical configuration data.

Use the following steps to compile off-line, new device configuration data:

1. From the Main menu, press “1” to access the Offline menu.
2. Press “1” to enter a new configuration. The Manufacturer menu appears.
3. Choose a manufacturer by scrolling to the manufacturer name with the DOWN arrow, then pressing RIGHT ARROW/SELECT. For a SITRANS P transmitter, choose Siemens. The Model menu appears.
4. From the Model menu, choose a device by scrolling through the list, then pressing RIGHT ARROW/SELECT. The Field Device Revision (Fld dev rev) menu appears.

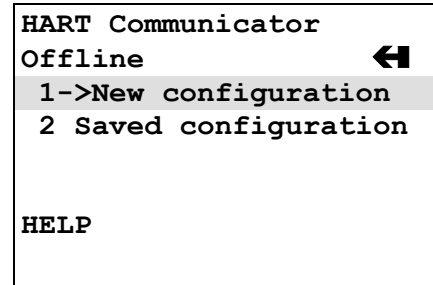

The Field Device Revision menu contains the currently installed software revisions for the field device and device descriptions (DD) for the model selected from the Model menu.

Select the software revision (RIGHT ARROW/SELECT or number) to access the Blank Template menu (at right). To display the software revision for a particular device, connect the Communicator to the device and follow instructions given in the device manual.

To find the field device revision (compatible device description) for a SITRANS P transmitter:

1. Connect the Communicator to the transmitter.
2. Apply power to the transmitter.
3. Turn on the Communicator.
4. In the Online menu, select “3 Device Setup.”
5. In the Device Setup menu, select “4 Detailed Setup.”
6. In the Detailed setup menu, select “4 Device Information.”
7. In the Device Information menu, select “6 Revision numbers.” Revision numbers for the Communicator and the transmitter will be listed.

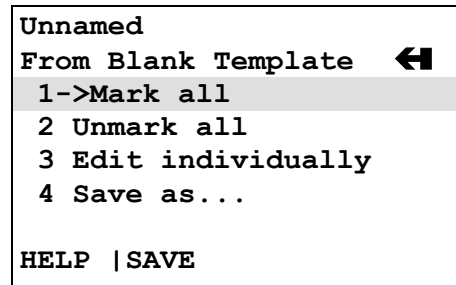

- With the Blank Template menu displayed, choose from the options available, as follows:

Mark All – Flags (selects) all configurable variables for sending to a connected HART-compatible device.

Unmark All – Remove the flags from all configurable variables in the configuration. Unmarked configuration variables are not sent to a connected device.

Edit Individually – Open the Edit individually menu (at right).

Example

The Edit individually menu permits the user to type or change a configuration parameter. For example, to add a tag, press the EDIT function key (F3) to and type the tagname. Then press NEXT to move to the next configurable parameter.

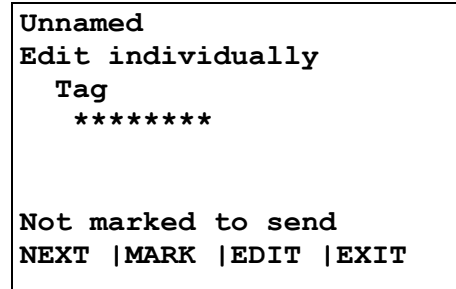

Save As. . .

Selecting the Save As option allows a new configuration to be saved to either the Memory Module or the Data Pack.

The Memory Module holds up to 10 typical configurations, and contains the operating system software and device application software in non-volatile memory. The Data Pack stores up to 100 typical configurations in nonvolatile, removable memory.

Example

From the Offline menu, choose 1 New configuration. This displays the Manufacturer menu. Choose a device, then choose a model from the Model menu. Choose a software revision from the Fld dev rev menu.

The Communicator creates a configuration and displays the Blank Template menu. Choose Save as... to display the Save as... menu (at right). With the Location highlighted, press the SAVE (F2) function key to save the configuration.

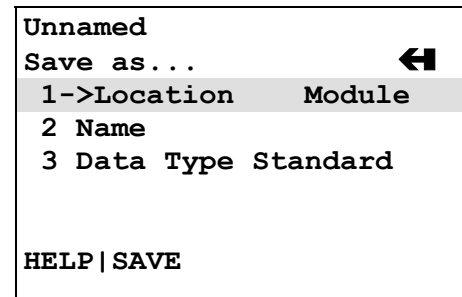

If the location highlighted is the Module, but the configuration is to be stored in the Data Pack, or vice versa, press the RIGHT ARROW/SELECT key to display the Location menu. Choose either Module or Data Pack by pressing ENTER (F4). This displays the Save as... menu again. Press SAVE (F2) to save the configuration in the desired location.

The Save As... menu also is used to enter or edit the configuration Name and Data Type. To name a configuration, simply choose option 2, then use the keypad with shift keys to enter the name as shown at right.

When the Save As... menu is displayed, one of the options – Standard, Partial, or Full – will be shown. To change the option, move the cursor to the Data Type _____ line of the Save As... menu and press the RIGHT ARROW/SELECT key to display the Data Type menu (below right).

Data Type Standard refers to all user-editable variables in a device configuration. Data Type Partial refers to only the marked editable variables. Data Type Full refers to a all device variables, whether user-editable or not. In general, it is best to save as Data Type Standard. Saving as Data Type Full preserves a complete configuration for future reference.

When all changes have been made, save the new configuration to either the Memory Module or the Data Pack and return to the Offline menu.

```

Unnamed
Name
  UNNAMED
  MYNAME#1
  _____
HELP | SAVE
  
```

```

Unnamed
Data Type
Standard
  Standard
  Partial
  Full
HELP           ESC | ENTER
  
```

2.5.1.2 Saved Configuration

The second option on the Offline menu is the Saved Configuration menu, which permits access to previously stored configuration data.

1. Press “2” from the Offline Menu to display the Saved Configuration menu (at right).
2. Select either Module Contents or Data Pack Contents to open stored configurations. Both storage locations list all saved configurations by assigned Tag. See XPAND (below) for more configuration identification details. (**Note:** The PC option shown on the menu is not operational with firmware release 1.6.)

The Module Contents menu, which lists the configurations currently stored in the Memory Module, is shown at right. The Data Pack menu is similar. Both give the user several options for handling and viewing configuration data, as explained below.

FILTR

The FILTR function key (F1) opens a menu that provides both Sort and Filter options. These options select only the chosen configurations from all those stored. This is particularly valuable for the Data Pack, which stores up to 100 configurations.

Sort allows unique device configurations to be grouped and displayed by Tag, Descriptor, or user-assigned Name.

Use Filter to group and display configurations according to certain characters within the chosen device identifier (Tag, Descriptor, or Name). Filter is useful for selecting all the tags from a certain area of the process or plant.

When setting up a Filter (see display at right), two wildcard characters, the period (.) and the asterisk (*) are used. The period replaces a single character of any value. The asterisk replaces one or more alphanumeric characters of any value.

For example, if A-*-1 is entered as the filter, the configurations displayed will be all those with device tags starting with A-, followed by any combination of characters (e.g., XYZ, S2, 3R) followed by a dash, followed by any single character (e.g., 1, D, M), and ending with a 1. Tags A-M1-B1, A-N2-Z1, and A-SF-X1 would display, whereas the tags BA53, PT101, and ATT48 would not.

```
HART Communicator
Saved Configuration ←
1->Module Contents
2 Data Pack Contents
3 PC
HELP
```

```
HART Communicator
Data Pack Contents ←
->PT101
PT102
PT103S
PT104
FILTR | XPAND
```

```
HART Communicator
Tag Filter
*
A-*-1
HELP | DEL | ESC | ENTER
```

XPAND

The XPAND function key allows a user to view the Tag, Descriptor, and Name for the configuration being edited or viewed. Selecting Compress restores the previous compressed display, which shows only the current Tag, Descriptor, or Name.

3. With the Module Contents or Data Pack Contents menu displayed, press the RIGHT ARROW/SELECT key to open the Saved Configuration menu for a device that was highlighted (at right).

Edit – displays the Edit menu, providing the same functions as described under “Edit individually” in Section 2.5.1.1. When editing off-line, only stored data may be edited. Moreover, data stored as a Partial configuration must be converted to a Standard configuration, then saved, prior to editing.

Copy To... – specifies the storage location for a copy of the configuration. Copy To... also provides a way to change the configuration name.

Send – sends a saved configuration to a connected device.

Print – not implemented with firmware release 1.6.

Delete – removes a saved configuration from memory. A confirmation message appears. Press Yes or No to complete the function.

Rename – provides access to the configuration name editing menu. After making name changes, enter and save the data to return to the previous storage location menu.

Compare – compares a selected device configuration from a stored location with other device configurations. The HART Communicator can compare device types, variables, marked lists, and other configuration parameters. Messages appear indicating if the configurations compared are the same or different.

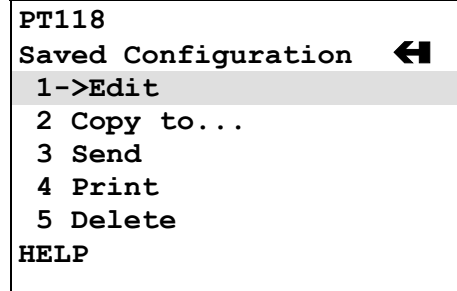

2.5.2 Online Menu

An operating transmitter can be tested and configured from the Online menu. Options available through the SITRANS P Online menu are summarized in Figure 2-5 (Appendix A contains a more detailed menu map). The Online menu is displayed when the Communicator contains a device description for the connected HART device. If not, the Generic Online menu is displayed (see Figure 2-6).

The Online menu can also be accessed from the Main menu by pressing “2 Online.”

Online Menu

When the Communicator is connected to a powered transmitter, it will poll the device to obtain: type, address, configuration, and process data. The Online menu shows the device type at the top of the display, if it is a supported device. SITRANS P-specific menu options are described in detail in Sections 3 and 6.

If a device description for the connected device is not in the Communicator, contact the device manufacturer. The Communicator provides a generic interface so that functions common to all HART-compatible devices can be accessed.

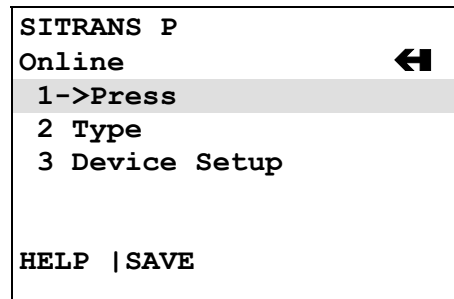

Generic Menu

The Generic Online menu (at right) is the first menu in the generic interface. It displays critical, up-to-date device information. Configuration parameters for the connected device may be accessed using the Device setup option. Figure 2-6 shows the complete Generic Online menu tree.

From the Online menu, use the options below to change device configurations.

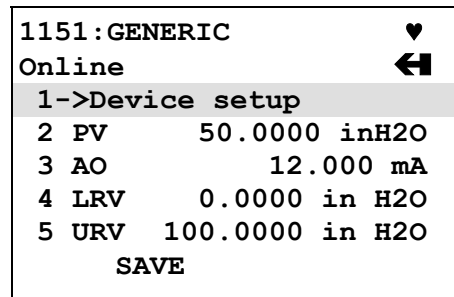

Device setup – provides access to the Device Setup menu. Configurable device parameters common to all HART-compatible devices can be accessed from this menu.

Primary Variable (PV) – the dynamic primary variable and the related engineering unit. When the primary variable contains too many characters to display on the Online menu, access the PV menu to view the primary variable and related engineering units by pressing “1.”

Analog Output (AO) – the dynamic output and the related engineering units. The analog output is a signal on the 4-20 mA scale that corresponds to the primary variable. When analog output contains too many characters to display on the Online menu, access the PV AO Menu to view the analog output and related engineering unit by pressing “3.”

1 Device setup*	1 Process variables	1 Pressure +			
		2 Percent range +			
		3 Analog output +			
		4 Sensor temperature +			
	2 Diagnostics and service	1 Diagnosis	1 Min / max pointer >		
			2 Operating hours >		
			3 Warnings / alarms >		
			4 Status >		
		2 Simulation / Test	1 Simulation		1 Loop Test
			2 Test		2 Inputs >
		3 Control modes	1 Local keys ctrl mode		1 Self Test
			2 Write protect (status)		2 Master reset
			3 Set write protect		
		4 Trim	1 Position correction		
			2 Sensor trim >		
			3 Trim analog output >		
		5 Restore manufacturers trims	1 All trims		
			2 DAC trims		
			3 Position correction		
			4 Sensor trim >		
		6 All measured values	1 Pressure +		
			2 Raw value		
	3 Sensor Temp +				
	4 El Temp +				
	5 AO +				
3 Basic setup	1 Tag				
	2 Unit				
	3 Position correction				
	4 LRV				
	5 URV				
	6 Damp				
	7 Transfer function				
4 Detailed setup	1 Sensors	1 Pressure sensor	1 Pressure +		
			2 Unit		
		2 Temperature sensor	1 Sensor temperature +		
			2 El temperature +		
	2 Signal condition	1 Process variables >			
		2 Position correction			
		3 Zero / span set >			
		4 Damping			
		5 Transfer function			
		6 Measuring speed			
	3 Output condition	1 Analog output +			
		2 HART output >		Polling address and number of preambles	
	4 Device information	1 Ranges and limits >		Module range, pressure USL and LSL, and minimum span	
		2 Common device information >		Manufacturer, model, measurement type, etc.	
3 Sensor information >			Process connection, flange type, etc.		
4 Remote seal >			Seal type, material, fill, etc.		
5 Local meter >			Type, engineering units, bargraph activation.		
6 Revision numbers >			Universal; field device DD, software/firmware, and hardware.		
5 Reviews >	Step thru configuration				
2 PV	Notes: * = Reached from the Online menu by pressing 3 Device setup				
3 AO	> = Press to access lower level menu(s) not shown				
4 LRV	+ = Active data displayed				
5 URV	HART Communicator, Rev 5				

FIGURE 2-5 SITRANS P Online Menu Map

1 Device setup	1 Process variables	1 Preset variable			
		2 Percent range			
		3 Analog output			
	2 Diagnostics and service	1 Test device	1 Self test		
			2 Status		
		2 Loop test			
		3 Calibration	1 Rerange	1 Keypad input	
			2 Trim analog output	2 Apply values	
			3 Sensor trim	1 D/A trim	
			2 Scaled D/A trim		
	3 Basic setup	1 Tag			
		2 Unit			
		3 Range values			
		4 Device information	1 Date		
			2 Descriptor		
			3 Message		
			4 Write protect		
	5 Meter type				
	5 Transfer function				
	6 Damping				
	4 Detailed setup	1 Sensors	1 Process variables		
			2 Sensor service	1 Sensor trim	
			3 Unit	2 Characterize	
		2 Signal condition	1 Process variables		
			2 Range values		
			3 Unit		
			4 Transfer Function		
5 Damping					
3 Output condition		1 Process variables	1 Loop test		
			2 D/A trim		
			3 Scaled D/A trim		
		2 Analog output			
		3 AO alarm type			
		4 HART output	1 Poll address		
			2 Number of request preams		
3 Burst mode					
4 Burst option					
4 Device Information	1 Field device info	1 Tag			
		2 Date			
		3 Descriptor			
		4 Message			
		5 Model			
		6 Write protect			
		7 Revision #'s			
		8 Final assembly #			
		9 Device ID			
		10 Distributor			
2 Sensor information					
3 Meter type					
4 Self test					
5 Review					
2 PV					
3 AO					
4 LRV					
5 URV					

FIGURE 2-6 Generic Online Menu Map

Lower Range Value (LRV) – the current lower range value and the related engineering unit. When the lower range value contains too many characters to display on the Online menu, access the PV LRV Menu to view the lower range value and related engineering unit by pressing “4.”

Upper Range Value (URV) – the current upper range value and the related engineering unit. When the lower range value contains too many characters to display on the Online menu, access the PV URV Menu to view the upper range value and related engineering unit by pressing “5.”

2.5.3 Frequency Device Menu

From the Main menu, press “3” to access the Frequency Device menu. This menu displays the frequency output and corresponding pressure output for current-to-pressure devices. For SITRANS P transmitters, the display frequency and pressure values are both “none.”

2.5.4 Utility Menu

From the Main menu, press “4” to access the Utility menu (at right). This menu provide functions that affect the operation of the Communicator, not the connected devices.

2.5.4.1 Configure Communicator

From the Utility Menu, press “1” to access the Configure Communicator menu (below right). Use this menu to set the polling, adjust the contrast of the LCD, set the Communicator shutoff time, or set how many diagnostics messages to ignore before a warning message is displayed.

Use the **Polling** option to direct the HART Communicator to search for a connected device. The Communicator finds every device in the loop and lists them by tag number. If Polling is Never Poll, then the Communicator will not find a connected device.

The **Contrast** menu is used to change the LCD contrast. Contrast returns to the default value when the Communicator is turned off.

Off Time is used to set the Communicator to turn off automatically when not in use to conserve battery power.

The Communicator normally displays diagnostic messages from a connected device. The **Ignore Diagnostics** option permits the user to specify the number of messages to ignore so that messages will not be displayed as often, extending the time between displayed messages. The message count defaults to a nominal count of 50 each time the Communicator is turned on.

```

HART Communicator
Utility ←
1->Configure Communicator
2 System Information
3 Listen for PC
4 Storage Location
5 Simulation
6 Selftest
  
```

```

HART Communicator
Configure Communica ←
1->Polling
2 Contrast
3 Off Time
4 Ignore diagnostics
5 Delete configs
HELP
  
```

The **Delete Configs** option is used to delete all configurations stored in the Module, data pack, or Hotkey menu.

2.5.4.2 System Information

From the Utility menu, press “2” to access the System Information menu (at right). This menu can be used to provide information on the motherboard (e.g., firmware revision number), the module hardware and software characteristics, and the Data Pack EEPROM.

```

HART Communicator
System Information  ←
1->Motherboard
2 Module
3 Data Pack

HELP|DEL |ESC |ENTER

```

2.5.4.3 Listen for PC

Not implemented in firmware release 1.6.

2.5.4.4 Storage Location

From the Utility menu, the Storage Location menu (at right) provides access to data concerning the Memory Module or the Data Pack. Information available through this menu includes a label for the Memory Module or Data Pack, a feature that displays the total storage used (bytes) and the storage remaining (“free” bytes). The PC selection is not implemented in firmware release 1.6.

```

HART Communicator
Storage location  ←
1->Module
2 Data Pack
3 PC

HELP|DEL |ESC |ENTER

```

2.5.4.5 Simulation

The HART Communicator provides a mode that allows users to simulate an on-line connection to a HART-compatible device without connecting to the device. The simulation mode is a training tool that allows users to become familiar with different devices before configuring them in a critical environment.

Simulation of an on-line connection is done by selecting a manufacturer from the Manufacturer menu, then selecting a device from the Model menu, just as is done when on-line. After selecting a software revision, the Online menu for the simulated device is displayed. Functions are the same as those available when on-line.

2.5.4.6 Selftest

Selftest performs a test of the Communicator.

2.6 USING THE QUICK ACCESS KEY

Pressing the Quick Access Key (Hot Key) while on-line displays the Quick Access Key menu, a user-definable menu that provides immediate access to up to 20 frequently performed tasks. The Quick Access Key menu is accessible when the Communicator is powered and on-line, or when the Communicator is off, by simply pressing the Quick Access Key. For the Quick Access Key to be active, the Communicator must be connected properly to a HART-compatible device.

From the factory, the Quick Access Key menu includes (for SITRANS P only):

Zero/Span set – View variables such as percent range, process value, set point, and valve.

Use of this function is described in Section 6.1.3. More options can be added to provide rapid access to frequently performed tasks. User-defined options can be deleted later, but the factory option is permanent.

To use the Quick Access Key:

1. Connect the Communicator to a powered HART-compatible device.
2. Press the Quick Access Key (upper right-hand key in the action keys group). The Communicator will power-up and display the Quick Access Key menu (at right).

Before any custom options have been installed, the Quick Access Key menu displays only the five factory-installed options. To add options, see Section 2.6.1.

3. Use the UP and DOWN arrows followed by the RIGHT ARROW/SELECT key to choose an option, or press the option's number on the keypad. The menu for the chosen option displays.
4. Follow the instructions given in Section 6.1.3 to use the option selected.
5. When finished, press the Quick Access Key to return to the previous menu.

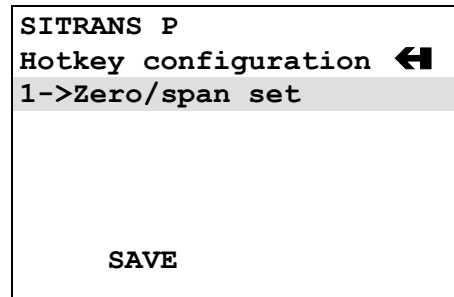

2.6.1 Adding Quick Access Key Options

The Quick Access Key menu contains space for up to 20 on-line options. For example, if device tags and damping must be changed often, simply add both of them to the menu. The Communicator automatically saves them so they can be accessed quickly by pressing the Quick Access Key.

From one of the menus or submenus reached via the Online menu, use the following steps to add customized options to the Quick Access Key Menu:

1. Using the UP or DOWN arrow keys, move the menu bar to highlight the option to be added to the Quick Access Key menu (e.g., Damping, under the Configure Xmtr\Sensor Input menu).
2. Press any shift key, release it, then press the Quick Access Key. The Hotkey Configuration menu displays (at right).

The Hotkey Configuration menu displays the new topic being added to the list of current Quick Access Key options. For example, in the figure at right, Damping is being added.

3. Press ADD (F3) to add the option. Pressing EXIT (F4) terminates the procedure and displays the menu that was displayed when “Shift,” Quick Access Key was pressed.
4. After pressing ADD (F3), either press ALL (F1) to add the new option to the Quick Access Key menu for all the HART-compatible devices supported by the Communicator or press ONE (F4) to add the option to the Quick Access Key Menu only for the type of device that is currently connected.
5. Next, the question “Mark as read-only variable on Quick Access Key menu?” may appear. Press YES (F1) to mark the variable for this option as read-only. Press NO (F4) to mark the variable as read/write. Marking a parameter for a device as read-only allows users to view, but not change, the parameter using the Quick Access Key Menu. Marking it as read/write permits the value to be changed from the Quick Access Key menu.

Finally, “Display value of variable on hotkey menu?” is displayed. Press YES (F1) to display the current variable associated with the option next to the option on the Quick Access Key menu as shown at right for Damping and Tag. Press NO (F2) not to display the variable on the Quick Access Key menu.

6. When finished adding options, press EXIT (F4) to exit the Hotkey Configuration menu and return to the menu of the last option deleted.

```
SITRANS P
Hotkey Configuration
ADD: Pres
Zero/span set

ADD | EXIT
```

```
SITRANS P
Hotkey Configuration ←
Zero/span set
Pres

EXIT
```

2.6.2 Deleting Quick Access Key Options

Use the following steps to delete an option from the Quick Access Key menu:

1. From any on-line menu, press any shift key, release it, then press the Quick Access Key.
2. The Hotkey Configuration menu displays (at right).
3. Using the UP or DOWN arrow key, move the menu bar to highlight the option to be deleted and press DEL (F2). Factory-provided options cannot be deleted.
4. When finished deleting options, press EXIT (F4) to exit the Hotkey Configuration menu and return to the menu of the last option deleted.

```
SITRANS P
Hotkey Configuration
ADD: Descriptor
↑
Range Xmtr
Damping
Tag
          DEL |ADD |EXIT
```

■

3.0 PRE-INSTALLATION TEST

Prior to installation, the transmitter can be tested and operated from the HART Communicator. This test consists of checking that the transmitter is operational and that all configuration information is correct. Section 5 Post-Installation Test provides an on-line test procedure. For an in-depth discussion of transmitter configuration, refer to Section 6 On-Line Configuration and Operation.

Important

Transmitter orientation will affect the analog output zero. Refer to Section 7.1 Calibration for details.

3.1 PROCEDURE

A complete transmitter functional test can be performed and configuration procedures can be practiced. To operate the transmitter on a test bench, make the connections shown in Figure 3-1. Figure 3-2 shows the connections if these tests are to be performed after transmitter installation. A pressure source can also be connected.

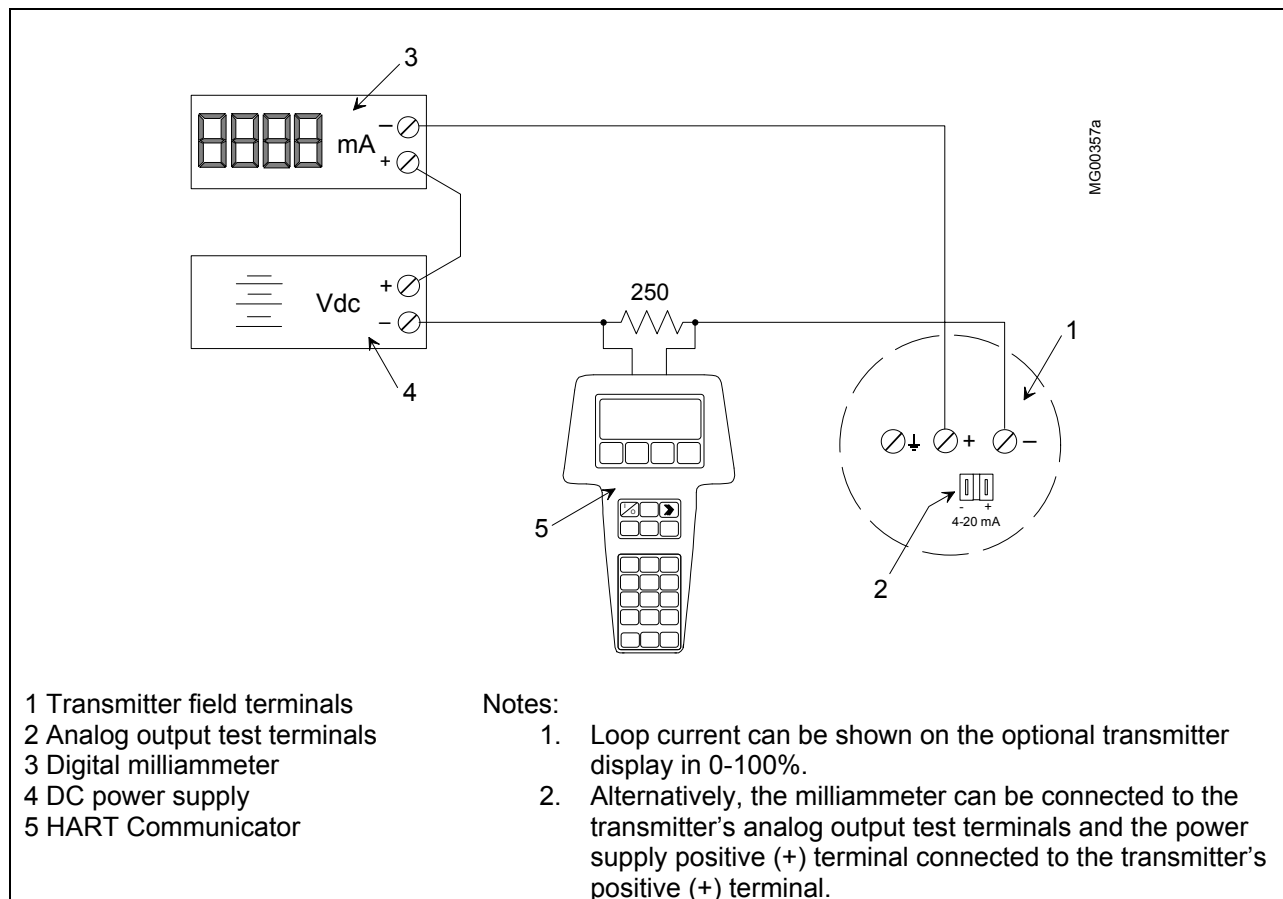

FIGURE 3-1 Bench Test Connections

Note: If using a Model 375 Field Communicator, see the inside of the front cover of this manual.

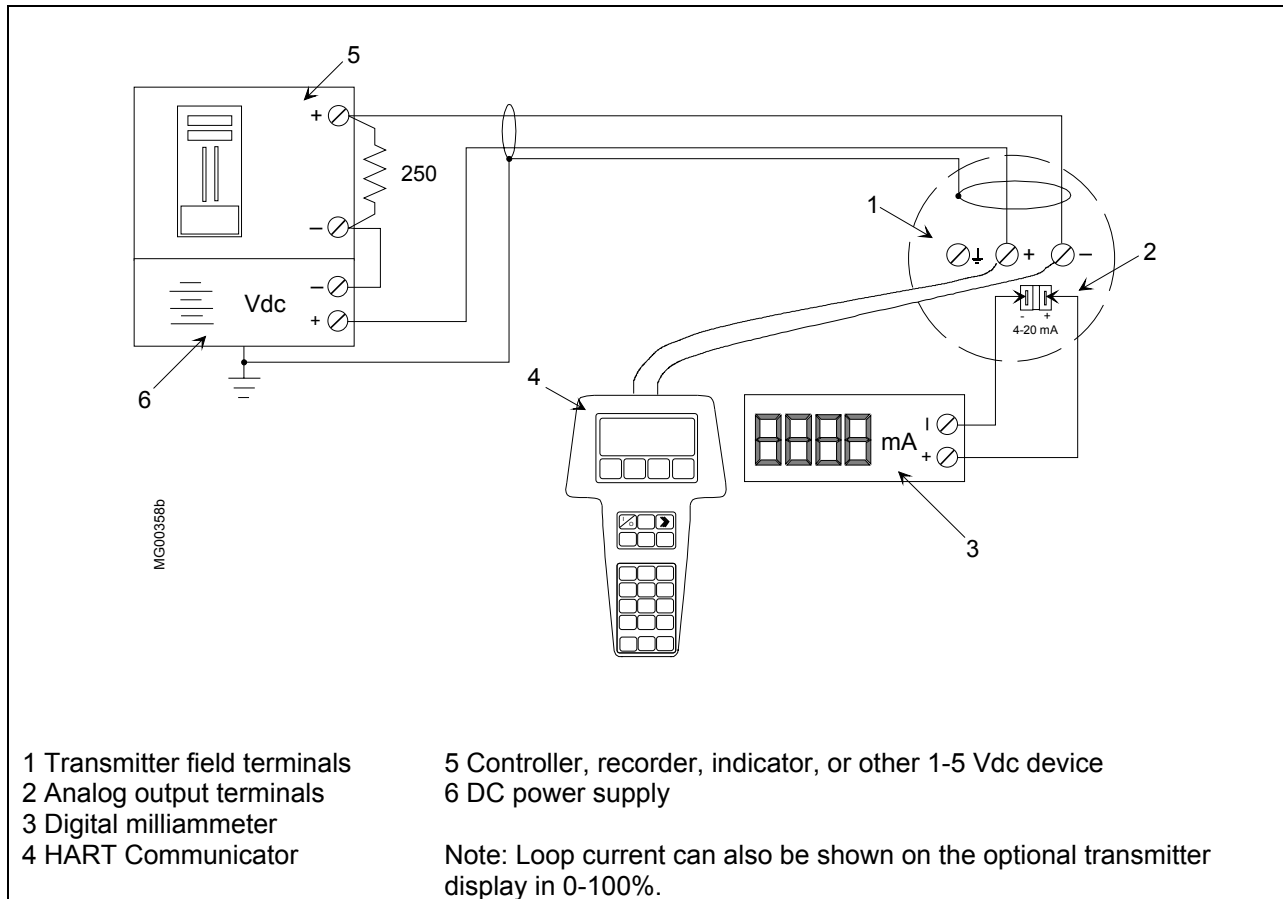

FIGURE 3-2 Field Test Connections

3.1.1 Test Equipment

TEST EQUIPMENT	DESCRIPTION (see Specifications, Section 9.3)
Power Supply	10.5 to 45 Vdc, see Power Supply Requirements, Section 4.3.5
Multimeter:	
Current	Range: 4 to 20 mA to measure loop current
Voltage	Range: 0-50 Vdc to measure power supply and loop voltage
Current Sense Resistor	250 to 1100Ω to support HART digital communications
Configuration Device	Model 275 HART Communicator or Model 375 Field Communicator
Pressure Source	Dead Weight Tester or similar device.

Note

Test equipment should be 2 to 10 times more accurate than the transmitter accuracy.

3.2 ESTABLISHING COMMUNICATION

1. Connect the transmitter, power supply, and HART Communicator in a loop.
2. Apply power to the transmitter.
3. Press the HART Communicator's I/O key. The first display is the Online menu (at right). Appropriate values for pressure and device type should be displayed.
4. If the Online menu does not appear, or if a "Device not found" message displays, check connections and power source and repeat the above steps.

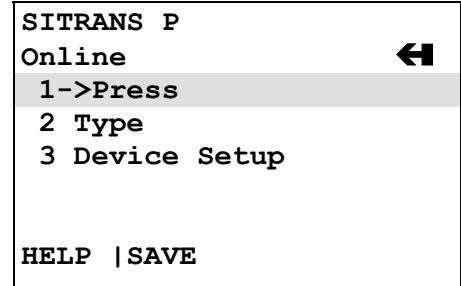

3.3 TESTING THE TRANSMITTER

Although a transmitter continuously performs an on-line self-test, a more extensive self-test can be performed when communication with the HART Communicator has been established.

1. In the Online menu, choose option 3 Device setup, then press 2 Diag/Service, and finally press 2 Simulation/Test.
2. In the Simulation/Test menu, choose option 2 Test and then press 1 Self test or press the RIGHT ARROW/SELECT key to start the test.
3. The transmitter performs the self-test.
 - If testing is successful, the message "Self test OK" appears and the Communicator returns to the Test menu.
 - If testing fails, the message "Transmitter FAILED the transmitter selftest" displays, and the transmitter goes to the prescribed failsafe condition. Refer to Section 7 Calibration and Maintenance to troubleshoot the transmitter.
4. Press the HOME softkey to return to the Online menu.

Note: If using a Model 375 Field Communicator, see the inside of the front cover of this manual.

3.4 REVIEWING CONFIGURATION DATA

Review the configuration before placing a transmitter in service to ensure that the proper data has been stored.

1. Establish communication as described in Section 3.2.
2. In the Online menu, press 3 Device Setup, then 5 Review.
3. Press NEXT to review configuration parameters. See the screen at right. To return to the Device setup menu, press EXIT. Parameters cannot be changed in the Review mode. Exit the Review mode and enter either Basic Setup or Detailed Setup to change parameters.
4. If configuration parameters have been changed, save the configuration. Note the filename and location.
5. To send the configuration to a transmitter:
 - 1) Press the LEFT ARROW/PREVIOUS key until the Main Menu is reached.
 - 2) Press 1 Offline, then press 2 Saved Configuration.
 - 3) Select the location of the configuration and then select the desired configuration from the list of stored configurations.
 - 4) Press 3 Send to download the configuration to the transmitter. If the configuration is incompatible with the transmitter, a warning message will appear.

```

SITRANS P
Review
  Pressure unit
    inH2O

HELP | PREV | NEXT | EXIT
  
```

3.5 CHECKING TRANSMITTER OUTPUT

To be sure that the transmitter is reading the proper pressure in the proper units, use a dead weight tester or other acceptable pressure standard to apply 0, 25, 50, 75, and 100% of input values to the transmitter. Check that the corresponding outputs are 4, 8, 12, 16, and 20 mA.

With the transmitter configured and powered, and with the test equipment in place, perform the following steps:

1. Connect the HART Communicator and press the I/O Key.
2. In the Online menu, press 3 Device setup, then 1 Process variables. View applied pressure and transmitter output.
3. Apply pressure representing 0% of the configured range. Wait at least 5 seconds.
4. The current should read 4.00 mA.
5. Repeat steps 3 and 4 for pressures representing 25, 50, 75, and 100% of the configured range. Check for the corresponding pressure readings and current values.

```

SITRANS P:          ♥
Process Variables   ◀
1->Press 0.000 inH2O
2 % rnge          1.00%
3 AO              4.000 mA
4 Snsr Temp      24.8°C
↓
HELP | SAVE | HOME
  
```

This completes the pre-installation test of the transmitter. ■

4.0 INSTALLATION

Transmitter installation is discussed in this section. Topics include: equipment delivery and handling, environmental and installation considerations, and mechanical and electrical installation.

IMPORTANT

Before installing or servicing the transmitter:

- Read the information on the transmitter's rating and approval plates and ensure that the correct model is at hand and that the correct procedures in this manual are followed. See Section 9.1 Model Designations for an explanation of the model designation alphanumeric sequence shown on the rating plate.
- The installation must conform to the National Electrical Code and all other applicable construction and electrical codes. Refer to the installation drawings in Appendix B when locating a transmitter in a hazardous area.
- Refer to Section 9.6 Hazardous Area Classifications for approval agency requirements that affect installation and use of the instrument and for additional statements concerning installation in a hazardous environment.

4.1 EQUIPMENT DELIVERY AND HANDLING

Prior to shipment, a transmitter is fully tested and inspected to ensure proper operation. It is then packaged for shipment. Most accessories are shipped separately. The contents of a box are listed on a packing slip.

4.1.1 Receipt of Shipment

Each carton should be inspected at the time of delivery for possible external damage. Any visible damage should be recorded immediately on the carrier's copy of the delivery slip.

Each carton should be unpacked carefully and its contents checked against the enclosed packing list. At the same time, each item should be inspected for any hidden damage that may or may not have been accompanied by exterior carton damage.

If it is found that some items have been damaged or are missing, notify Siemens immediately and provide full details. In addition, damage must be reported to the carrier with a request for their on-site inspection of the damaged item and its shipping carton.

4.1.2 Storage

If a transmitter is to be stored for a period prior to installation, review the environmental requirements in Section 9.3 Specifications.

4.2 ENVIRONMENTAL CONSIDERATIONS

Many industrial processes create severe environmental conditions. The conditions at each transmitter location must be within the specifications stated in Section 9.3 Specifications.

Although the transmitter is designed to perform in harsh conditions, it is prudent to choose a location that minimizes the effects of heat, vibration, shock, and electrical interference.

CAUTION

Exceeding the specified operating temperature limits can adversely affect performance and may damage the instrument. See the rating plate and Section 9 Model Designations and Specifications for temperature and other environmental ratings.

4.3 PRE-INSTALLATION CONSIDERATIONS AND CALCULATIONS

These sub-sections provide pre-installation considerations and calculations that are needed to ensure successful mechanical and electrical installations.

4.3.1 Mechanical

- Select the application. Series DSIII transmitters are suitable for, but not limited to:
 - Flow measurement
 - Gauge pressure measurement
 - Level measurement
 - Draft pressure measurement
 - Absolute pressure measurement
 - High differential pressure measurement
 - Hydrostatic tank gauging measurement
- Determine the physical mounting of the transmitter. Consider:
 - Optional brackets for pipe mounting or surface mounting
 - Pipe or tank wall thickness, diameter, rigidity, and freedom from vibration
 - Clearance for transmitter installation and maintenance
 - Need to rotate the enclosure and display for viewing ease

Refer to Figures 9-1 through 9-4 for transmitter dimensions and to the figures in Sections 4.4 and 4.5 for typical mechanical installations. Refer to Section 9.3 for mechanical and environmental specifications.

- Determine if an explosion-proof or intrinsically safe installation is required. Refer to the transmitter's rating plate for electrical classifications and to Section 4.7 and Section 9. Hazardous area information for specific approval agencies can be found in Section 9.6 and Appendix B.

An intrinsically safe installation requires user-supplied intrinsic safety barriers that must be installed in accordance with barrier manufacturer's instructions for the specific barriers used.

Transmitter certification is based on the "entity" concept in which the user selects barriers that permit the system to meet the entity parameters.

- Absolute and Differential Models – Consider pressure piping recommendations. Refer to Section 4.3.3.
- Determine conduit routing. Refer to Section 4.5.3.
- Consider bolting a transmitter to a two- or three-valve manifold.

Differential Construction Model – Install a three-valve manifold because this device provides both an equalizing valve and high and low pressure block valves. Use the equalizing valve to equalize pressure between inputs before calibrating or servicing the transmitter. Use block valves to isolate the transmitter from the process for servicing or removal.

Gauge Construction Model – Install a two-valve manifold for similar purposes to those listed above.

Flange Model – Consider using flushing rings to flush and clean the process connection without removing the flange.

Prepare installation site drawings showing the following:

- Location of the Master Device (e.g., HART Communicator or controller), location and identification of each transmitter, and location of any signal cable junctions for connecting the HART Communicator
- Routing plan for signal cable(s) and for power cable(s)

4.3.2 Electrical

- Determine transmitter operating mode (analog or digital) and type of network needed; refer to Section 4.3.4.
- Determine minimum power supply requirements. Refer to Section 4.3.5.
- Select twinaxial cable (shielded twisted pair wire) and determine maximum network cable length. Refer to Sections 4.3.6 and 9.5.
- Develop the cable route and method of support and protection (e.g. conduit, cable tray). To improve immunity to interference, keep cable separated from cables with voltage greater than 60V and away from large electrical equipment.
- Determine the need for network junctions. Refer to Section 4.3.7.
- Intrinsically Safe installations will need barriers. Refer to Section 4.3.8.
- Consider the effect of connecting additional equipment (e.g., recorder, loop powered display) to the network. Refer to Section 4.3.9.
- Read Section 4.3.10 for shielding and grounding recommendations.

4.3.3 Impulse Piping for Absolute and Differential Models

Impulse piping is the piping to be connected to the transmitter's process connection(s). For suggested flow and level measurement piping arrangements, refer to:

- Differential Model - Figures 4-1 and 4-2
- Absolute Model - Figures 4-3 and 4-4
- Flange Model - Figure 4-5

Note the following when planning and installing piping.

- Install impulse piping in accordance with ANSI Code B31.1.0.
- Make impulse piping length as short as possible to reduce frictional loss and temperature-induced pressure variations. However, when using impulse lines on a high temperature process, locate the transmitter far enough away from the heat source to keep it within temperature specifications [28°C (50°F) per foot cooling to a normal ambient is assumed for uninsulated impulse lines].
- For lines between the process and transmitter, use impulse piping of 3/8" OD or larger to avoid friction effects (causes lagging) and blockage.
- Use the least number of fittings and valves possible to minimize leakage problems. Teflon[®] tape is the recommended thread sealant for process connections at the transmitter.
- Valves used in pressure service should be either globe or gate type. Valves used in gas service should be of a type that does not permit condensate to build up behind the valve.
- Install sediment chambers with drain valves to collect solids suspended in process liquids or moisture carried with non-condensing gases.
- Install air chambers with vent valves at high point in piping to vent gas entrained in process liquid.
- Remote diaphragm seals can be used to keep corrosive liquid or gas from the transmitter pressure inlets and isolation diaphragm.
- Alternatively, use sealing fluid to isolate the process from the transmitter. Sealing fluid must be of greater density than process fluid and non-miscible.
- For transmitters located above the process, slope piping from the transmitter at least 1 inch/foot (83 mm/M) down toward process. For transmitters below the process, slope piping at least 1 inch/foot (83 mm/M) up to process.
- Protect pressure lines (by shielding if necessary) from objects or equipment that may bend or kink the line causing fluid flow restriction.
- Protect the pressure lines from extreme temperature ranges. Lines should be protected from freezing by installing a heat trace.
- A three-valve manifold should be used with a differential transmitter model. A two-valve manifold can be used with an absolute model to permit servicing and zero checks.

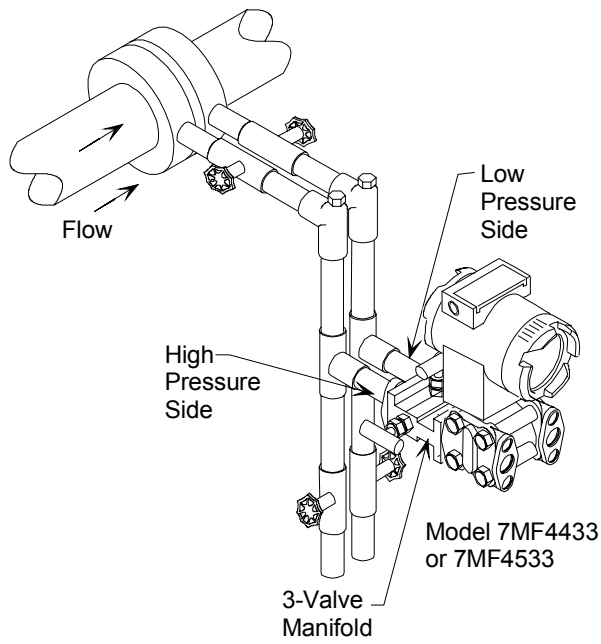

Horizontal Main Line Flow
Transmitter Below Orifice - Preferred for Liquids and Steam

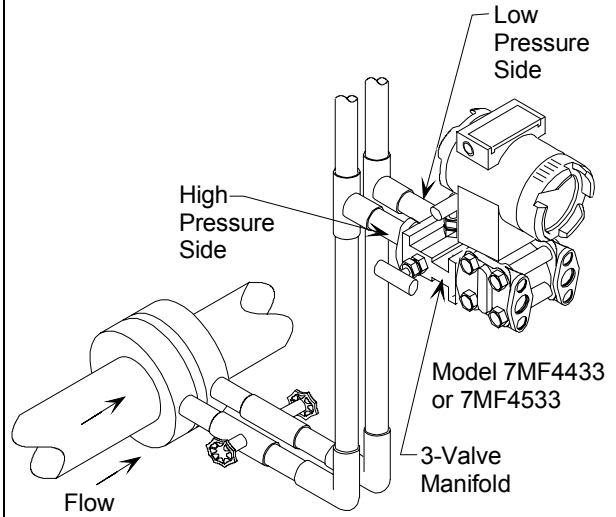

Horizontal Main Line Flow
Transmitter Above Orifice - Preferred for Gas Flow

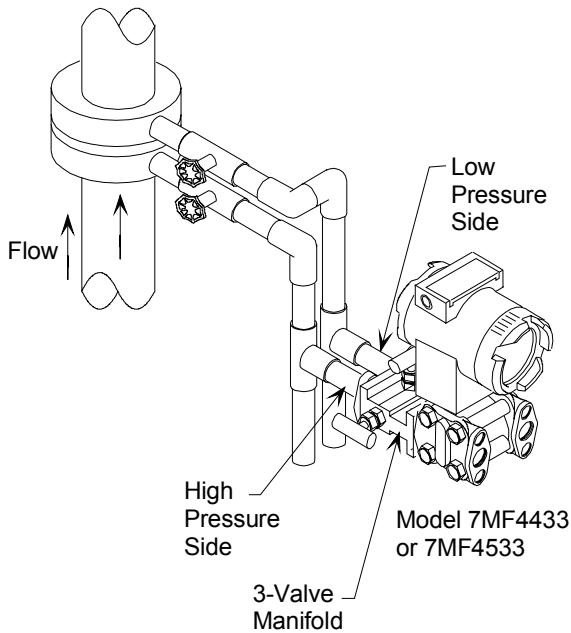

Vertical Main Line Flow
Transmitter Below Orifice

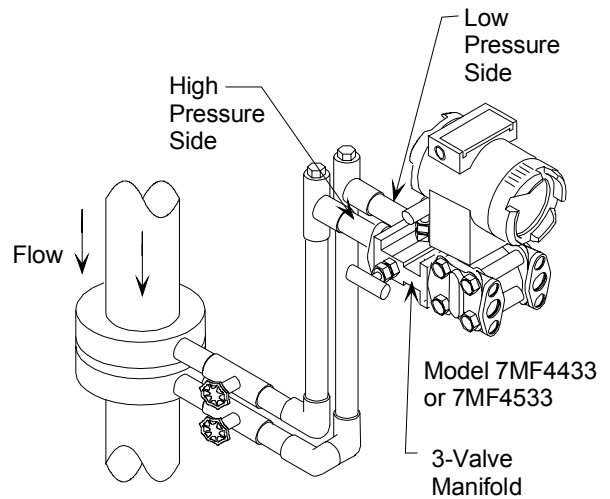

Vertical Main Line Flow
Transmitter Above Orifice

MG00344a

FIGURE 4-1 Differential Flow Measurement Piping for Gas and Liquid

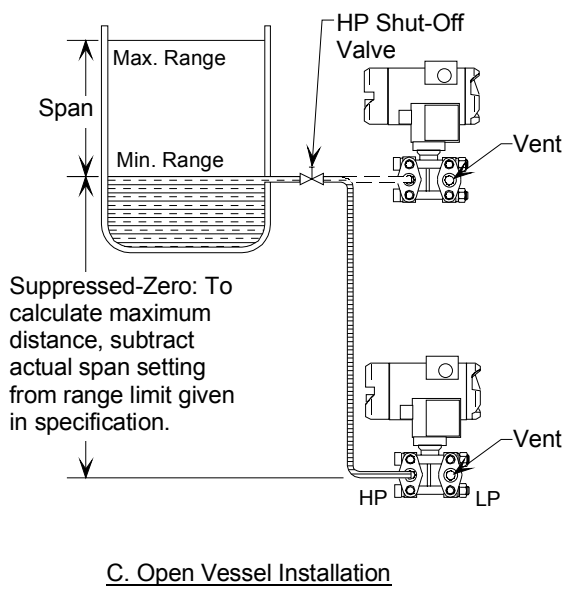
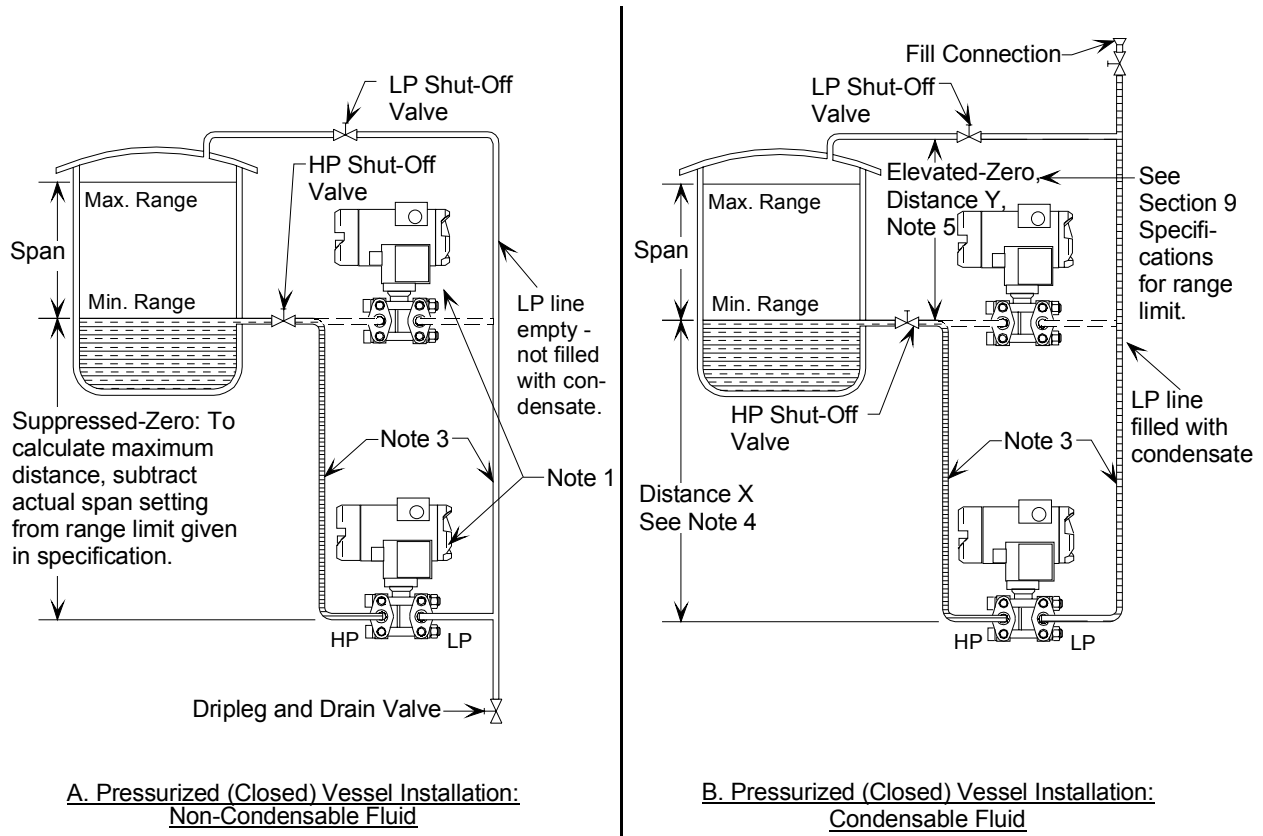

- Notes:
1. Transmitter may be mounted at or below the minimum level to be measured.
 2. Open or vented vessels require only a high pressure (HP) connection.
 3. High pressure line senses static pressure plus level. Low pressure line senses pressure only. The two pressures oppose each other, canceling the effect of static pressure.
 4. Distance "X" can be any distance since both high and low pressure lines have equal and opposite forces which cancel the forces created by this distance.
 5. Entire length of low pressure pipe is kept full of condensate to act as a reference.
 6. See Appendix C for information on calculating suppressed and elevated zero ranges.

MG00346b

FIGURE 4-2 Differential Liquid Measurement Piping

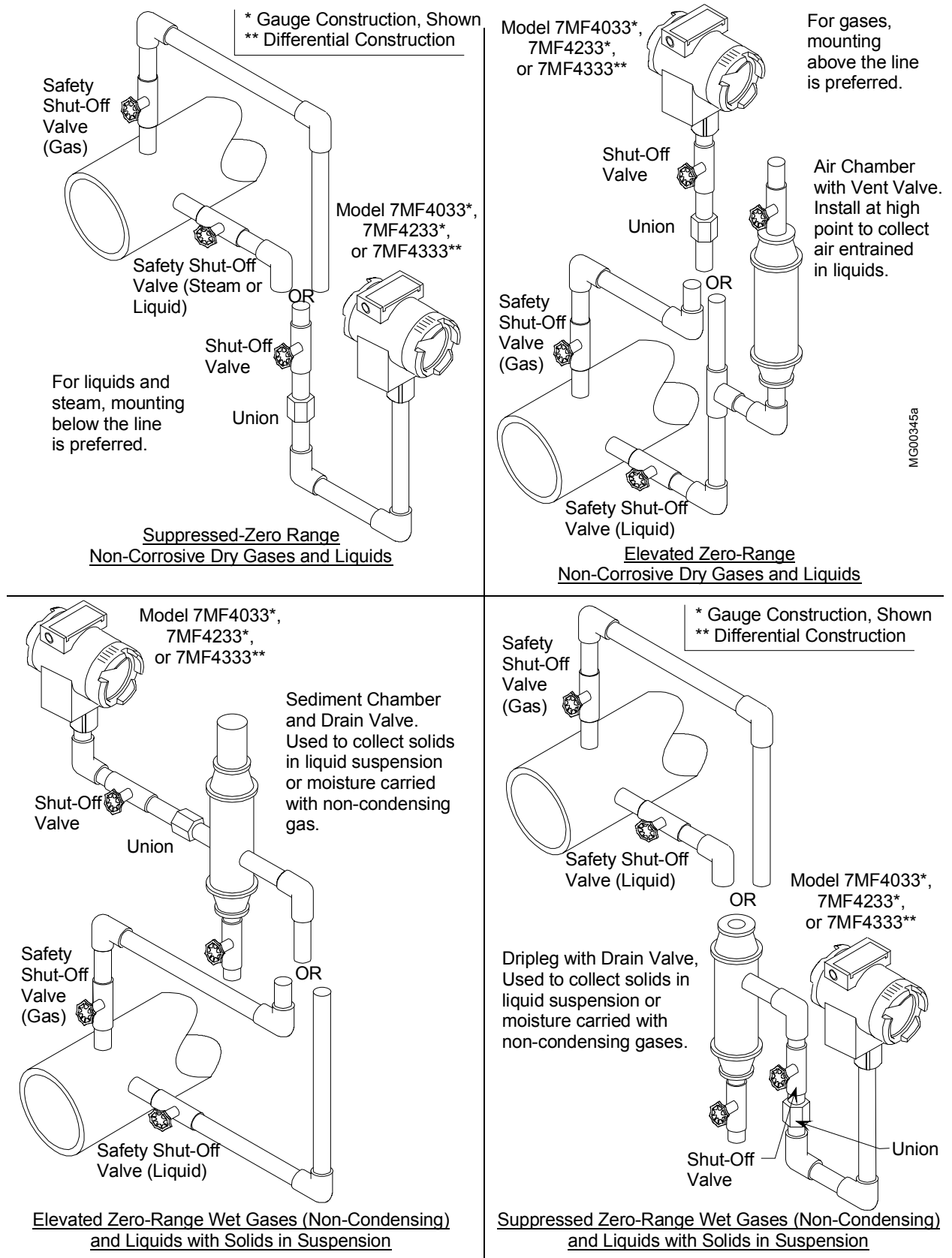

FIGURE 4-3 Absolute or Gauge Pressure Measurement Piping

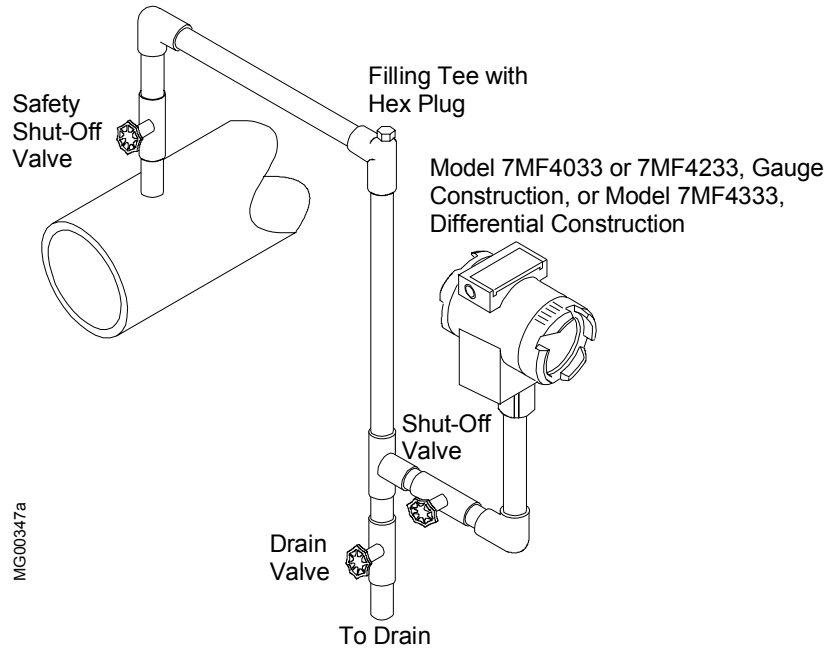
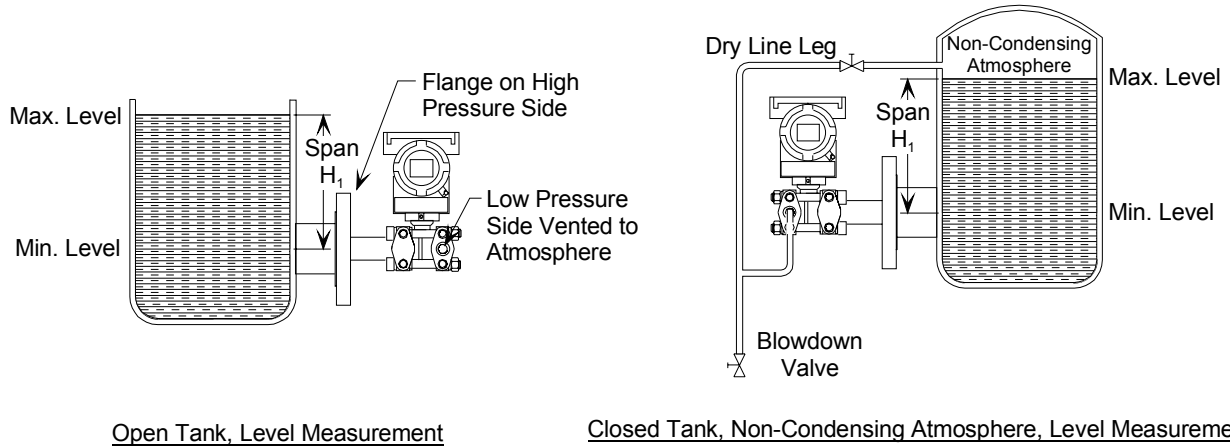

FIGURE 4-4 Steam Service, Below the Line Mounting



Open Tank, Level Measurement

Closed Tank, Non-Condensing Atmosphere, Level Measurement

MG00348b

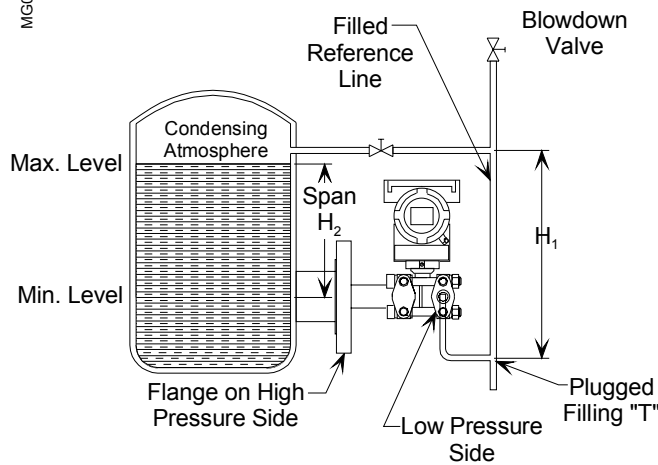

Closed Tank, Condensing Atmosphere, Level Measurement

Notes:

1. Transmitter may be mounted at or below the minimum level to be measured.
2. Open or vented vessels require only a high pressure (HP) connection.
3. High pressure line senses static pressure plus level. Low pressure line senses pressure only. The two pressures oppose each other, canceling the effect of static pressure.
4. Distance "X" can be any distance since both high and low pressure lines have equal and opposite forces which cancel the forces created by this distance.
5. Entire length of low pressure pipe is kept full of condensate to act as a reference.
6. See Appendix C for information on calculating suppressed and elevated zero ranges.

FIGURE 4-5 Open and Closed Tank Level Measurement, Flange Mounted Transmitters

4.3.4 Transmitter Operating Mode and Network Type

A transmitter outputs either an analog current or an equivalent digital signal, depending upon the selected operating mode. The operating mode also determines the type of network (Point-to-Point or Multi-Drop) to be installed, as shown in Table 4-1 and the following subsections.

TABLE 4-1 Operating Mode and Network

OPERATING MODE	NETWORK TYPE	NETWORK FIGURE(S)
Analog	Point-to-Point	4-6, 4-7, and 4-8
Digital	Multi-Drop	4-9

Note: If using a Model 375 Field Communicator, see the inside of the front cover of this manual.

4.3.4.1 Analog Mode

When a transmitter is configured for analog mode operation, the following statements apply.

- The transmitter outputs a 4-20 mA signal for input to devices such as controllers and recorders.
- A Point-to-Point network is used comprising a transmitter, Primary/Secondary Master, and other non-signaling devices. The transmitter polling address is 0 (zero).

Point-to-Point networks are shown in Figures 4-6, 4-7, and 4-8.

- The optional display can be used for local indication of transmitter output.
- Each transmitter is factory configured for analog mode unless otherwise ordered. The polling address is set to zero (0).
- A Model 275 HART Communicator is used for configuration, diagnostics, and reporting the current process variable.

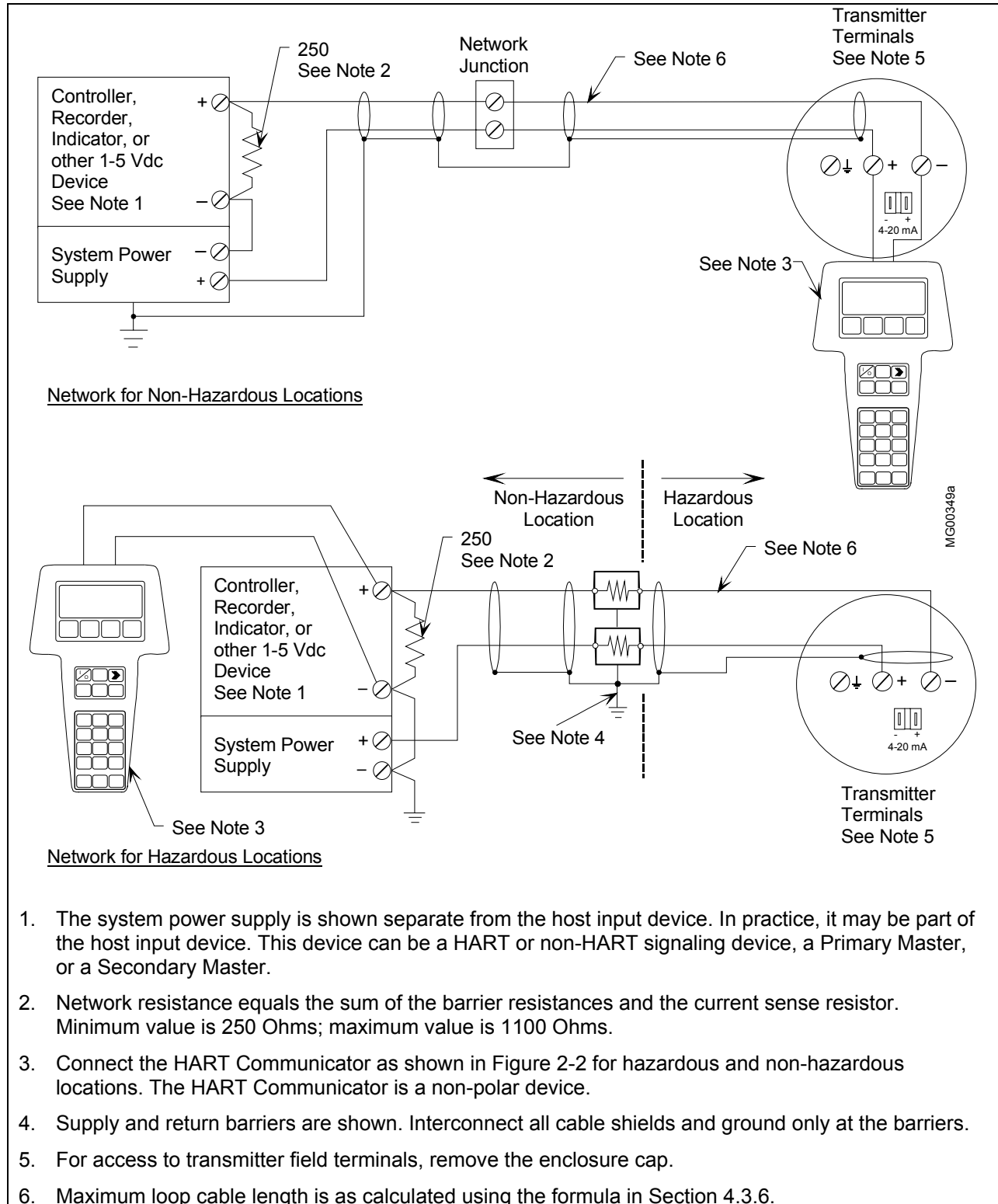
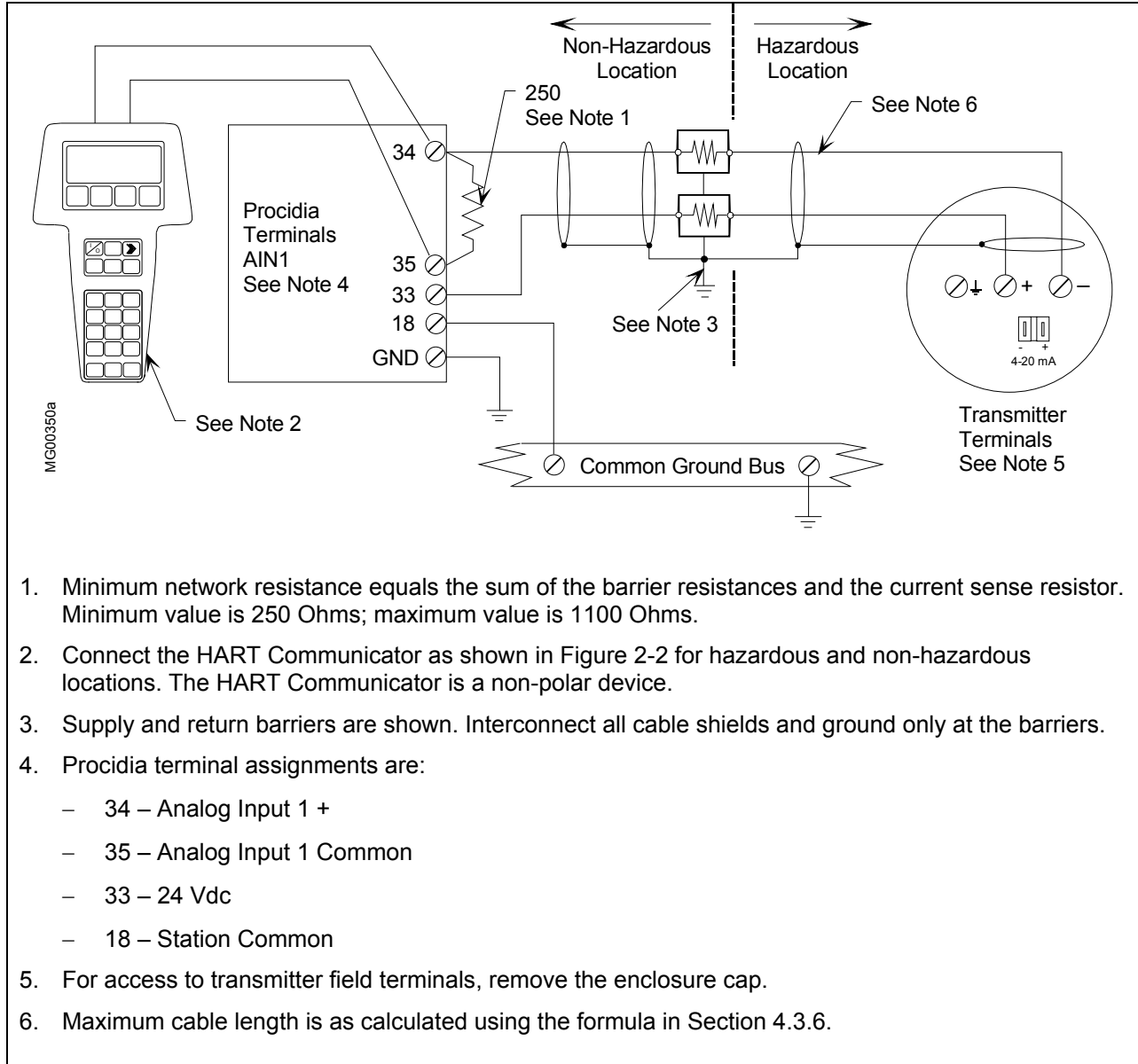

FIGURE 4-6 Point-To-Point Network (Analog Mode)



1. Minimum network resistance equals the sum of the barrier resistances and the current sense resistor. Minimum value is 250 Ohms; maximum value is 1100 Ohms.
2. Connect the HART Communicator as shown in Figure 2-2 for hazardous and non-hazardous locations. The HART Communicator is a non-polar device.
3. Supply and return barriers are shown. Interconnect all cable shields and ground only at the barriers.
4. Procidia terminal assignments are:
 - 34 – Analog Input 1 +
 - 35 – Analog Input 1 Common
 - 33 – 24 Vdc
 - 18 – Station Common
5. For access to transmitter field terminals, remove the enclosure cap.
6. Maximum cable length is as calculated using the formula in Section 4.3.6.

FIGURE 4-7 Procidia to Transmitter Connections (Analog Mode)

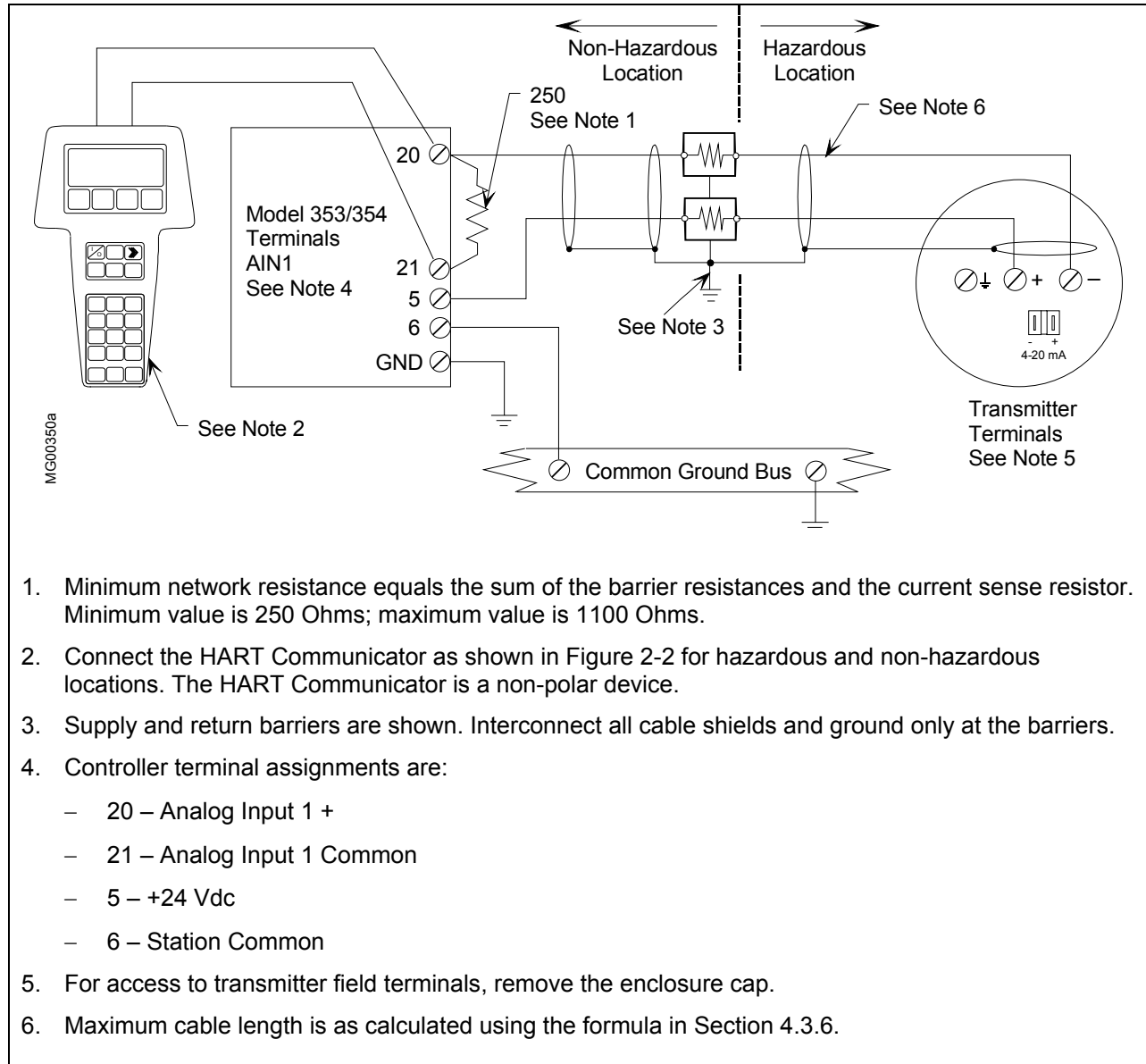

FIGURE 4-8 Model 353/354 to Transmitter Connections (Analog Mode)

4.3.4.2 Digital Mode

When a transmitter is configured for digital mode operation, the following statements apply.

- Process and configuration data are transmitted digitally. The analog output of each transmitter is “parked” at 4 mA.
- Employs a Multi-Drop network. See Figure 4-9.
- The optional display can be used for local indication of transmitter output.

The number of allowable network elements is:

- Primary and Secondary Masters - 1 each
- Transmitters - 1 to 15
- The HART communication source can be a Primary or Secondary Master. A Primary Master can be used for data acquisition, maintenance, or control purposes. A Secondary Master, the HART Communicator, for example, may be used for configuration, diagnostics, and reporting current process variable.
- Place the transmitter in the digital mode by assigning it a polling address (1 to 15) with the HART Communicator (see Section 6).
- Each transmitter connected to a network must have a unique address.

4.3.5 Power Supply Requirements

A power supply¹ is needed to power the transmitter(s). The power supply can be:

- A separate stand-alone supply capable of powering several transmitters. It can be mounted in a control room or in the field. Follow the power supply manufacturer’s recommendations with regard to mounting and environmental considerations.
- Located in a controller (such as a Primary Master) or other station able to safely provide additional operating current and meet the power supply specifications of Section 9.3.

Determine needed power supply output voltage by calculating the Network Resistance and consulting the adjacent figure. It shows the minimum power supply voltage needed for the calculated Network Resistance.

The total Network Resistance is the sum of the Current Sense Resistance, end-to-end Barrier Resistance (if used), wire resistance, and any other resistances in the loop. The minimum Network Resistance (see Section 10 Glossary) required to support HART communications is 250Ω. The maximum resistance is 1100Ω. Refer to Section 4.3.5.1 or 4.3.5.2 for calculations.

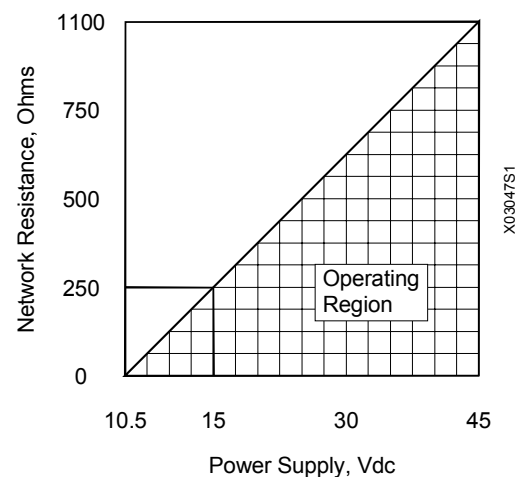

¹ An SELV (Separated Extra-Low Voltage) power supply is suggested; see IEC 364-1 and IEC 536.

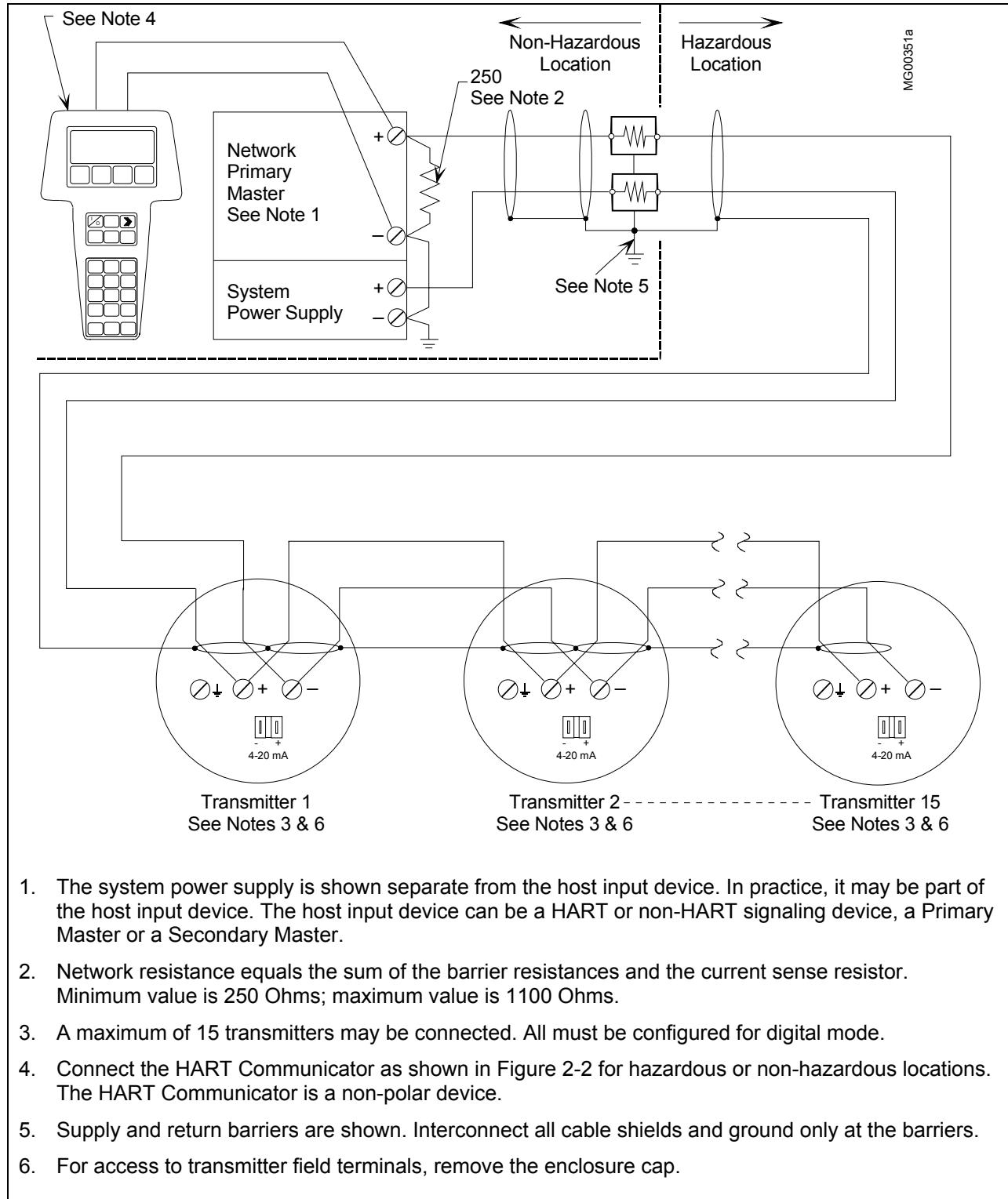

1. The system power supply is shown separate from the host input device. In practice, it may be part of the host input device. The host input device can be a HART or non-HART signaling device, a Primary Master or a Secondary Master.
2. Network resistance equals the sum of the barrier resistances and the current sense resistor. Minimum value is 250 Ohms; maximum value is 1100 Ohms.
3. A maximum of 15 transmitters may be connected. All must be configured for digital mode.
4. Connect the HART Communicator as shown in Figure 2-2 for hazardous or non-hazardous locations. The HART Communicator is a non-polar device.
5. Supply and return barriers are shown. Interconnect all cable shields and ground only at the barriers.
6. For access to transmitter field terminals, remove the enclosure cap.

FIGURE 4-9 Multi-Drop Network (Digital Mode)

4.3.5.1 Point-to-Point Network

The graph in Section 4.3.5 defines an analog mode transmitter's operating region for the allowable ranges of supply voltage and network resistance. Perform the following calculations to ensure that the power supply output voltage permits the transmitter to remain within the indicated operating range.

1. Calculate the minimum power supply output voltage.

The minimum network power supply voltage requirement is a function of Network Resistance and full scale current (20 mA), and is calculated by the following formula:

$$\text{Minimum Power Supply Output Voltage} = 10.5 \text{ volts} + (0.02 \times \text{Network Resistance in ohms})$$

Power supply output voltage must be greater than the calculated value. The minimum voltage across the input terminals of a transmitter is 10.5 volts.

2. Calculate the maximum power supply output voltage.

The maximum network power supply voltage is a function of Network Resistance and zero scale current (4 mA), and is calculated by the following formula:

$$\text{Maximum Power Supply Output Voltage} = V_{\max} + (0.004 \times \text{Network Resistance in ohms})$$

Power supply output voltage must be less than the calculated value. The maximum voltage (V_{\max}) permitted across the input terminals is:

- Non-intrinsically safe transmitter: 45 volts
- Intrinsically safe transmitter: 30 volts

4.3.5.2 Multi-Drop Network

Perform the following simple calculations to ensure that the power supply output voltage permits the Transmitter to remain within its operating range.

1. Calculate the minimum power supply output voltage.

Minimum network power supply voltage is a function of Network Resistance and the total current draw of all transmitters in the network, and is calculated by the following formula:

$$\text{Minimum Supply Output Voltage} = 10.5 \text{ volts} + [(0.004 \times \text{number of transmitters on Network}) \times (\text{Network Resistance})]$$

Power supply output voltage must be greater than the calculated value. The minimum voltage across the input terminals of a transmitter is 10 volts.

2. Calculate the maximum power supply output voltage.

Maximum network power supply voltage is a function of Network Resistance and total current draw of all the transmitters in the network, and is calculated by the following formula:

$$\text{Maximum Supply Output Voltage} = V_{\max} + [(0.004 \times \text{number of transmitters on Network}) \times (\text{Network Resistance})]$$

Power supply output voltage must be less than the calculated value. The maximum voltage (V_{\max}) permitted across the input terminals of a transmitter is:

- Non-intrinsically safe transmitter: 45 volts
- Intrinsically safe transmitter: 30 volts

The maximum number of transmitters that can be connected to a Multi-Drop Network is 15. Each transmitter is “parked” in a low current draw mode (4 mA) to conserve power. Ensure that the network power supply is capable of sourcing the total current consumed by the number of transmitters on the network.

4.3.6 Determining Network (Loop) Length

A cable length calculation is necessary when HART communication is to be employed. Cable capacitance directly affects maximum network length.

4.3.6.1 Cable Capacitance

Cable type, conductor size, and recommended cable model numbers are stated in Section 9.5.1 Two-Wire Cable.

Cable capacitance is a parameter used in the calculation of the maximum length of cable that can be used to construct the network. The lower the cable capacitance the longer the network can be. Manufacturers typically list two capacitance values for an instrumentation cable:

1. Capacitance between the two conductors.
2. Capacitance between one conductor and the other conductor(s) connected to shield. This capacitance is the worst case value and is to be used in the cable length formula.

4.3.6.2 Maximum Cable Length Calculation

The maximum permissible single-pair cable length is 10,000 feet (3000 meters) or less as determined by the following formula:

$$L = (65,000,000 / R \times C) - (C_f + 10,000 / C)$$

Formula Definitions:

L: The maximum total length of cable permitted to construct the network. L = feet when C is in pF/ft;
L = meters when C is in pF/meter.

R: The Network Resistance which is the ohmic sum of the current sense resistance and barrier resistance (both return and supply), if any, in the network and the resistance of the wire.

C: Cable capacitance per unit length between one conductor and the other conductor connected to the shield. C may be in pF/ft or pF/meter.

C_f: Total input terminal capacitance of field instruments; the Primary Master is excluded. C_f is given by the following formula:

$$C_f = (\text{sum of all } C_n \text{ values}) \times (5000)$$

Where C_n is an integer (e.g., 1, 2, 3) corresponding to the input terminal capacitance of a Field Instrument. C_n values are determined as follows:

FIELD INSTRUMENT CAPACITANCE C_n VALUE

Less than 5000 pF	1
5000 pF to less than 10000 pF	2
10000 pF to less than 15000 pF	3
15000 pF to less than 20000 pF	4
20000 pF to less than 25000 pF	5
For field instruments without C _n values, use C _n = 1	



For an intrinsically safe installation, refer to the Control Drawing(s) in Appendix B for entity parameters, which include C_i transmitter input capacitance, and other installation data.

Example Calculation:

Assume a network consists of two field instruments (both C_n = 1).

Let R = 250Ω, C = 40 pF/ft, C_f = (1 + 1) x 5000 = 10,000

Then L = (65,000,000 / (250 x 40)) - ((10,000 + 10,000) / 40) = 6000 feet (1800 meters)

4.3.7 Network Junctions

A network junction is shown in Figure 4-6. It is a wiring junction installed at a convenient point in the loop to facilitate wiring, testing, and troubleshooting. Typically the junction is a conventional terminal block mounted on a panel with a protective cover, cabinet, or junction box to enclose and protect wiring terminals.

Multiple junctions can be installed to provide field access terminals for the connection of a HART Communicator. Note the following:

- Network with barriers – Locate a junction anywhere along the network in the non-hazardous area.
- Network without barriers – A junction may be located anywhere along the network between the power supply and transmitter.
- A junction should be a simple electrical series connection containing NO repeaters or other devices (active or passive) that can degrade HART communications.

4.3.8 Safety Barriers

Installed safety barriers must comply with the following:

- Locate intrinsic safety barriers between the system power supply (e.g., Primary Master, if used) residing in the non-hazardous area and the transmitter(s) in the hazardous area.
- Combined or separate supply and return barriers may be used.
- For an intrinsically safe application, the DC voltage applied to the safe side of the barrier must be 0.6 Vdc less than the rated barrier working voltage.
- An active supply barrier must be operated within its specified input working voltage.
- Barrier shunt impedance to ground to the HART range of frequencies (500 Hz to 2500 Hz) shall not be less than 5000Ω.
- Barrier end-to-end resistance, stated by the manufacturer, is used in calculating the maximum Network cable length and minimum and maximum network voltages.
- The barrier shall be installed and wired in accordance with the manufacturers instructions.

4.3.9 Connection of Miscellaneous Hardware

Miscellaneous non-signaling hardware (e.g., recorders, current meters) may be connected to a Point-to-Point network in accordance with the following list.

Important

No non-signaling hardware (meters or measuring devices) may be connected to a Multi-Drop network since the transmitters, in this mode, do not output an analog process variable.

- Miscellaneous hardware may be series or parallel connected to the network according to its function.
- Miscellaneous hardware must be passive two-terminal devices.
- Miscellaneous hardware may not generate any type of noise or signals, other than noise that is inherent in resistive components.
- Individual miscellaneous hardware must meet the following requirements:
 - Capacitance to ground.....50 pF maximum
 - Resistance to ground 1 MΩ minimum
 - Impedance if series connectedLess than 10Ω
 - Impedance if parallel connectedGreater than 50kΩ

The maximum number of miscellaneous devices per network is 16. The combined electrical characteristics may not exceed the following:

- Maximum capacitance to ground800 pF
- Minimum resistance to ground62.5k Ω
- Maximum series impedance.....160 Ω
- Minimum parallel impedance3125 Ω

4.3.10 Shielding and Grounding

GROUNDING

Ground the transmitter's enclosure through a 16 AWG (1.3 mm²) or larger copper wire to a low resistance ground, such as a nearby metal cold water pipe. A grounding screw for this purpose is provided on the outside of the enclosure beneath the field terminals cap (Figure 1-7). The ground wire should be installed even though the enclosure is often grounded through the electrical conduit or, in some transmitter models, through the process connections and piping.

SHIELDING

Shielded loop cable is recommended. The preferred method of grounding that shield is shown in Figures 4-6 through 4-9.

Ground the cable shield at one point. Multiple grounds can cause signal error and poor HART performance. The location of the ground connection is often determined by the installation environment (hazardous or non-hazardous) or by the requirements of a regulating agency.

The following grounding practices are field proven and will reduce magnetically coupled interference. Select the appropriate option from the three bulleted items below for the installation at hand.

- Hazardous location - ground the shield(s) only at the barrier(s) or as recommended on the appropriate control (installation) drawing and by the certifying agency.
- Non-hazardous location - ground the shield at the network power supply.
 - Ground the cable shield to the power supply ground terminal. Do not connect the cable shield at the transmitter.
 - If a network junction box is used, splice the input and output cable shields and isolate them from ground.
- Non-hazardous location - ground the shield at the Transmitter
 - Ground the cable shield at the ground screw inside the transmitter's signal terminal compartment.
 - Power supply (+) and (-) connections must be floated.
 - If a network junction box is used, splice input and output shields and isolate them from ground.

4.4 MECHANICAL INSTALLATION

This section describes the mechanical installation of a transmitter and the installation of electrical conduit for wiring. Transmitter dimensions are given in Figures 9-1 through 9-4. Related mounting information for optional mounting bracket kits is provided in Figures 4-10, 4-11, and 4-12. Table 1-1 correlates measurement, model number, measuring cell, and figure number.

Mount a transmitter in any position (orientation). The mounting position can cause a zero shift, however, any zero shift is simply calibrated out with the transmitter installed in its final mounting position. Refer to Section 7 Calibration and Maintenance for details.

The transmitter enclosure can be rotated relative to the measuring cell to clear an obstruction or to allow viewing the optional display. The display can then be rotated in 90° increments for ease of reading. Refer to Section 4.5 for details.

Be sure to allow sufficient clearance for:

- Connection to impulse piping and installation of conduit
- Removal of the enclosure end caps
- Wiring, cleaning, and servicing of the transmitter
- Viewing of the optional display
- Access to the configuration pushbuttons

4.4.1 Pipe Mounting, Differential and Gauge Construction

A differential or absolute transmitter can be mounted to a vertical or horizontal 2-inch pipe using an optional mounting bracket kit; kit part numbers are given in Section 9.2 Accessories.

1. Refer to the appropriate figure and determine orientation of bracket and transmitter on selected pipe.
 - See Figure 4-10 for Absolute Pressure Models 7MF4033 and 7MF4233, gauge construction.
 - See Figure 4-11 for Absolute Pressure Model 7MF4333, differential construction.
 - See Figure 4-11 or 4-12 for Differential Pressure Models 7MF4433 and 7MF4533.
2. As shown in the appropriate figure, fasten the transmitter to the mounting bracket with the supplied hardware.
3. Fasten the mounting bracket to the pipe using the supplied hardware.
 - 1) At the selected location on the pipe and in the desired orientation, place the pipe groove side of the mounting bracket against the desired part of the pipe surface.
 - 2) Slip the U-bolt around the pipe and through one of the two pairs of mounting holes in the bracket.
4. Place a supplied washer and hex nut on each end of the U-bolt and hand tighten the nuts. Rotate the bracket around the pipe to place the transmitter in the desired position and secure the bracket to the pipe. Tighten mounting hardware:
 - Models 7MF4033 and 7MF4233 - 275 in/lbs (31.1 Nm)
 - Models 7MF4333, 7MF4433, and 7MF4533 - 400 in/lbs (45.2 Nm)
5. Rotate the enclosure or reposition the optional display as necessary. Refer to Section 4.5.

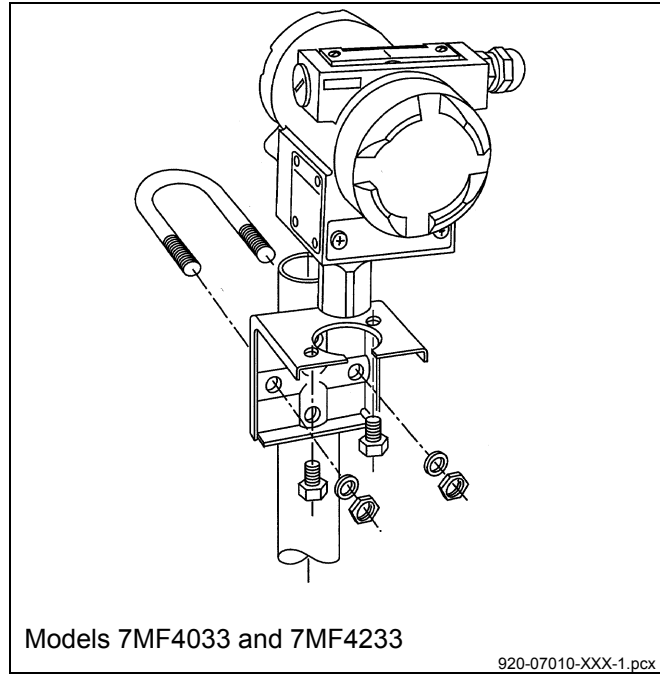

FIGURE 4-10 Pipe Mounting, Gauge Construction

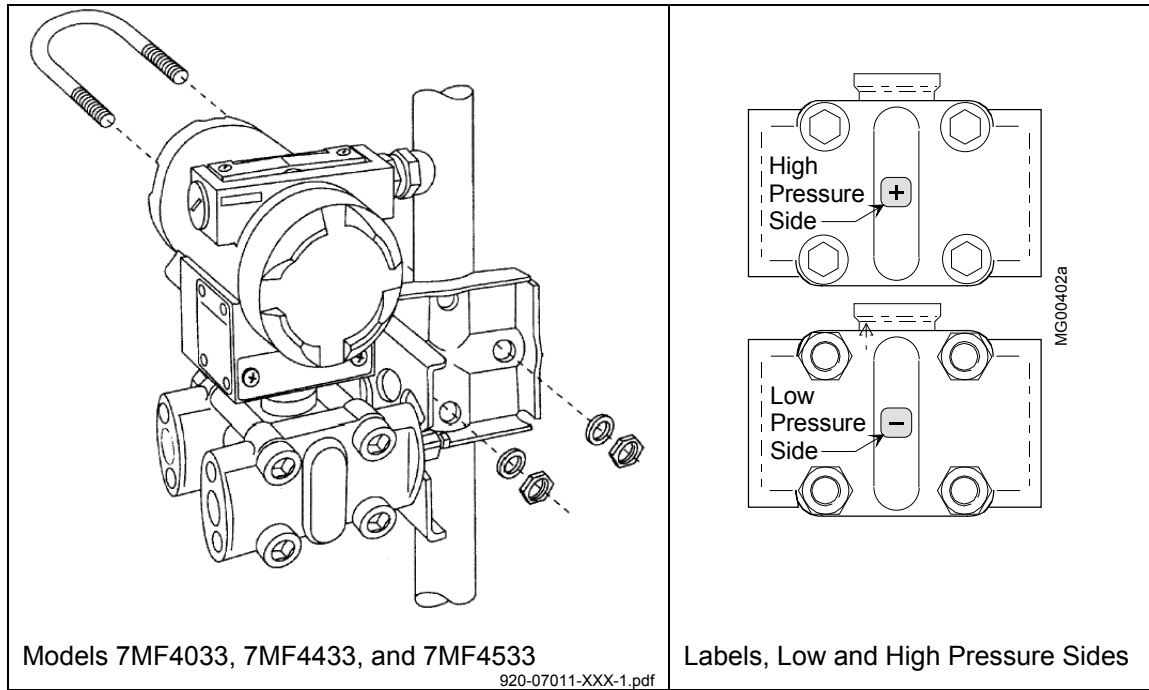

FIGURE 4-11 Pipe Mounting, Differential Construction

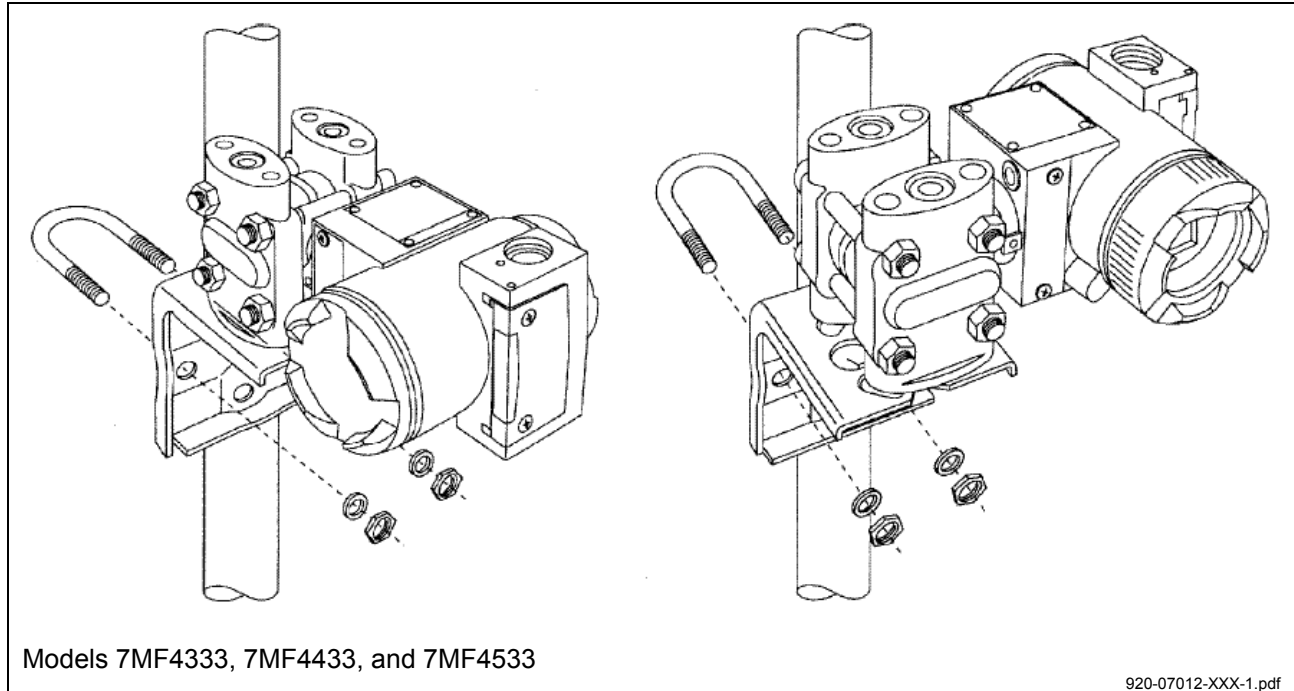
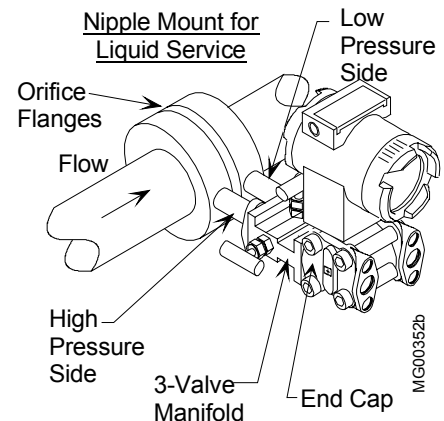

FIGURE 4-12 Differential Construction, Position Options

4.4.2 Direct Mounting to Process, Model 7MF4433 or 7MF4533

A differential transmitter can be interfaced to the process through a two- or three-valve manifold and supported by the piping connections (3-inch nipples) if mounted directly at the point of measurement.

Transmitter process connections are on 2.13-inch (54 mm) centers to allow direct mounting (bolting) to a manifold with the same spacing. Each transmitter process connection (end cap) has two tapped 7/16-20 mounting holes and a 1/4 NPT tapped pressure inlet. High pressure (+) and low pressure (-) sides of the transmitter are marked by labels (see Figure 4-11) and engraved on the capsule between the end caps.



Process orifice flanges with standard 2.13-inch spacing permit a transmitter and two- or three-valve manifold combination to be direct mounted.

The procedure for mounting a transmitter to a two- or three-valve manifold, and the manifold to the orifice flanges, is covered by the installation instructions supplied by the manifold manufacturer. The following is a guide and may need to be modified for some installations. Teflon[®] tape is the recommended thread sealant for process connections at the transmitter.

1. If installed, remove process connection blocks from the transmitter's end caps (process manifold).
2. Press the supplied O-ring seals into the grooves in the face of the two- or three-valve manifold and bolt the transmitter end caps to the transmitter side of the two- or three-valve manifold. Tighten mounting bolts to 400 in/lbs (45.2 Nm).

3. Thread ½" nipples, 3 inches (or less) in length, into the high- and low-pressure ports of the orifice flanges. Thread sealant must be used.
4. Thread the process connection blocks directly onto the nipples. Thread sealant must be used. The 1/2 NPT tapped hole in a process connection block is off center to accommodate 2-inch or 2.25-inch centers. For 2.13" pipe centers, the tapped holes should be offset to the right side.
5. Place the supplied Teflon gaskets on the connection blocks and bolt them to the manifold. Tighten the mounting bolts according to the manifold manufacturer's recommendations.
6. Rotate the enclosure or reposition the optional display as necessary. Refer to Section 4.5.

4.4.3 Flange Mounting, Model 7MF4633/7MF4912

A liquid level transmitter can be flange mounted directly to the point of measurement on a vessel. The flange-mounted diaphragm is factory assembled to the high-pressure side of the transmitter measuring cell.

Figure 9-4 shows a typical flanged level transmitter. Table 4-2 includes the following mounting information:

- Flange thickness
- Flange diameter and pressure rating
- Number of flange mounting holes
- Flange mounting hole diameter
- Flange bolt circle diameter

Refer to Figure 9-4 and Table 4-2 when performing the following procedure:

1. Determine needed bolt length. The user must supply mounting bolts, nuts, and washers. Bolt length is determined by the combined thickness of the flange mounted on the vessel and the transmitter's flange.
2. As necessary, loosen the enclosure rotation set screw and rotate the enclosure for clearance and best viewing of the optional display.
3. Bolt the transmitter's flange to the vessel's flange. Four mounting positions (90° increments) are possible with 2-inch flanges and eight positions (45° increments) are possible with 4-inch flanges.
4. Rotate the enclosure or reposition the optional display as necessary. Refer to Section 4.5.

TABLE 4-2 Flange And Extension Dimensions**A. Flange Dimensions**

SIZE	DIM "D"	DIM "BC"	DIM "T"	DIM "ED"	DIM "RF"	BOLT DIA	NO. OF BOLTS	FLANGE PER
2" – 150#	6.00 (152.40)	4.75 (120.65)	0.75 (19.05)	1.95 (49.53)	0.06 (1.58)	5/8	4	ANSI B16.5
2" – 300#	6.50 (165.10)	5.00 (127.00)	0.88 (22.23)	1.95 (49.53)		5/8	8	
3" – 150#	7.50 (190.50)	6.00 (152.40)	0.94 (23.81)	2.81 (71.37)		5/8	4	
3" – 300#	8.25 (209.55)	6.625 (168.28)	1.13 (28.58)	2.81 (71.37)		3/4	8	
4" – 150#	9.00 (228.60)	7.50 (190.50)	0.94 (23.81)	3.70 (93.98)		5/8	8	
4" – 300#	10.00 (254.00)	7.875 (200.03)	1.25 (31.75)	3.70 (93.98)		3/4	8	
50MM – 10/16 BAR	6.50 (165.00)	4.92 (125.00)	0.71 (18.00)	Consult Factory	0.12 (3.00)	M16	4	DIN 2526 TYPE C
50MM – 25/40 BAR	6.50 (165.00)	4.92 (125.00)	0.79 (20.00)			M16	4	
80MM – 10/16 BAR	7.87 (200.00)	6.30 (160.00)	0.79 (20.00)			M16	8	
80MM – 25/40 BAR	7.87 (200.00)	6.30 (160.00)	0.94 (24.00)			M16	8	
100MM – 10/16 BAR	8.66 (220.00)	7.09 (180.00)	0.79 (20.00)			M16	8	
100MM – 25/40 BAR	9.25 (235.00)	7.48 (190.00)	0.94 (24.00)			M20	8	

B. Extension Length

DIM "L"	0 (0.00)	2.00 (50.80)	4.00 (101.60)	6.00 (152.40)

Notes:

- Dimensions are in inches (millimeters).
- End cap can be rotated 180° for top or bottom vent/drain, side vent option only.

4.5 MECHANICAL INSTALLATION, ALL MODELS

The following subsections describe rotating the enclosure housing relative to the measuring cell to clear obstructions or view the optional display, orienting the display for ease of reading, and installing electrical conduit and cables.

4.5.1 Enclosure Rotation

1. Loosen the enclosure setscrew using a 3/32" (3 mm) Allen wrench. See Figure 4-13. The enclosure can be rotated approximately 135° in either direction from the point where the enclosure rotation arrow points directly at the enclosure setscrew. See Figure 4-13.

Important

If the high end of the ramp-shaped recess in the enclosure neck is rotated past the enclosure rotation arrow on the measuring cell, damage to internal electrical connections can occur requiring replacement of the measuring cell.

After positioning the enclosure, tighten the enclosure setscrew to between 30.1 in-lbs and 31.9 in-lbs (3.4 N-m and 3.6 N-m).

2. Position the display as necessary. Refer to Section 4.5.2.

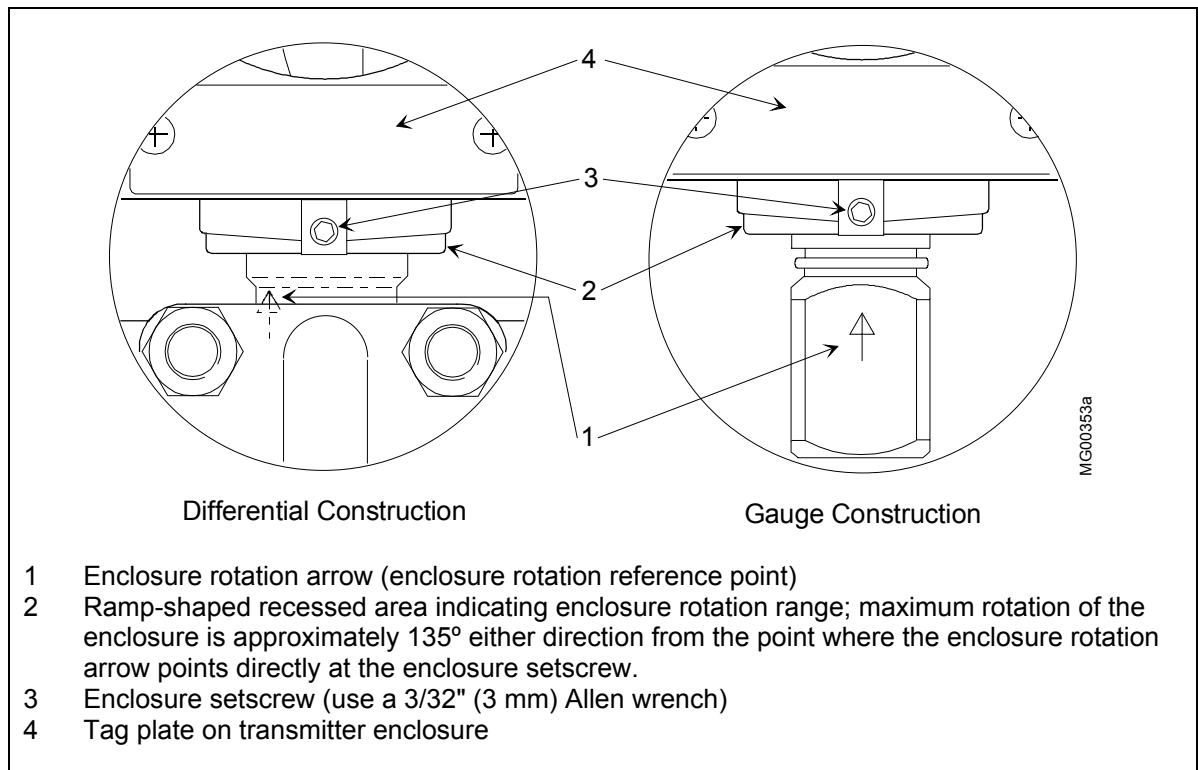



FIGURE 4-13 Enclosure Rotation Considerations

4.5.2 Display Orientation

As supplied the display is oriented for viewing with the transmitter installed vertically, as shown below and by most of the illustrations in this manual. When the transmitter is installed in another orientation, perform the following steps to reorient the display for ease of reading.

1. Turn off power to the transmitter.
2. Remove the enclosure cap that has the sightglass by rotating the cap counterclockwise.
3. Fasten an anti-static wrist strap on your wrist and ground it to the transmitter ground screw. 
4. Use a Phillips blade screwdriver to remove the two screws holding the display. The display is electrically connected to the transmitter electronics by the display cable. Refer to Figure 4-14.
5. Hold the display just in front of the transmitter enclosure and rotate it in quarter turns to find the viewing position where reading is easiest. Four positions, 90° apart, are provided. Do not rotate the display more than 180° in a clockwise or counterclockwise direction.
6. Align the two holes in the display circuit board with the hex standoffs in the enclosure and install the two screws removed above.
7. Install the enclosure cap and remove the anti-static wrist strap.

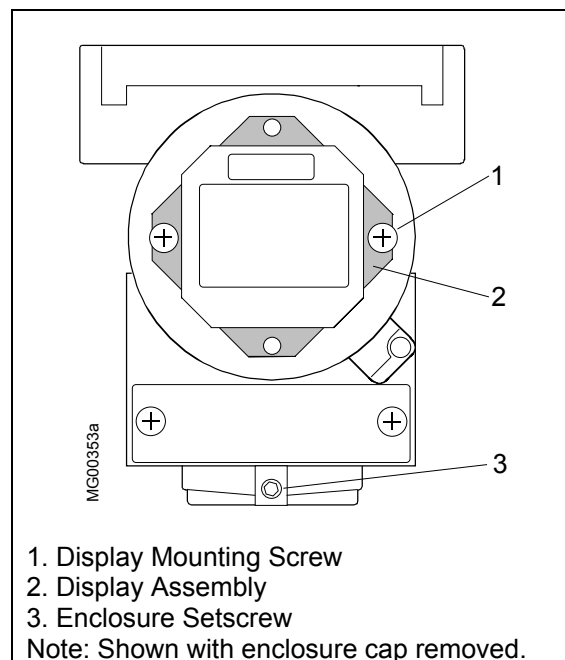

FIGURE 4-14 Display Removal and Repositioning

4.5.3 Electrical Conduit and Cable Installation

All electrical conduit and all signal wires must be supplied by the user. Access to electrical terminals is described in Section 4.5.2.3.

For conduit and cable routing, refer to user's installation drawings. Installation of conduit and cabling should follow the guidelines given below.

4.5.3.1 Conduit

- Transmitter conduit inlets accept male conduit fittings. Refer to the transmitter's rating plate and Section 9.1 to determine whether conduit threads are 1/2-14 NPT or M20 x 1.5.

Seal NPT fittings with Teflon tape; seal M20 fittings with a soft-setting sealing compound rated for at least 105°C (221°F).

- When routing conduit, avoid areas that might subject the conduit to chemical or physical abuse or areas with high electromagnetic interference/radio frequency interference (EMI/RFI) conditions.
- Install conduit for field wiring.
- If a high humidity environment can exist and the transmitter is located at a low point in the conduit run, install drain seals at the transmitter's conduit inlets to prevent condensation from entering the transmitter. See Figure 4-15.
- Remove all sharp edges or burrs from conduit that may damage wires. 18 inches of flex conduit is recommended at each transmitter.

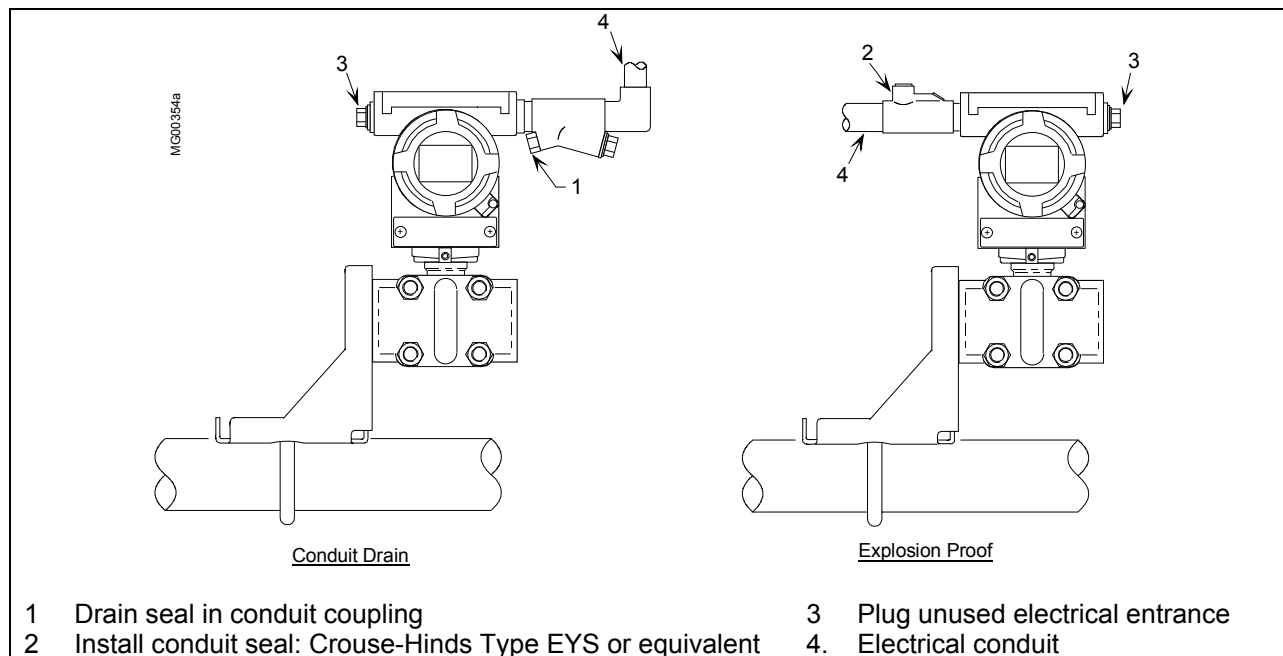

FIGURE 4-15 Conduit Drain and Explosion Proof Installations

4.5.3.2 Cables

- Mark or tag each cable conductor as either LOOP (+) or LOOP (-) to ensure correct connection at the transmitter.
- Use pulling grips and cable lubricants for easier cable pulling. Pull cable through conduit into transmitter terminal compartment.
- Do not exceed the maximum permitted pulling tension on the cables. Maximum tension is normally specified as 40% of the cable's breaking strength.
- Do not exceed the maximum conduit fill specified by the National Electric Code.

4.5.3.3 Access to Transmitter Terminal Compartment

1. Remove the enclosure cap closest to the electrical entrance by turning it counterclockwise.
2. Install the enclosure cap by turning it clockwise until the O-ring contact the enclosure. Tighten the cap one additional turn to compress the O-ring.

4.6 ELECTRICAL INSTALLATION

This section describes loop wiring for Point-to-Point and Multi-Drop networks. Refer also to Section 4.8 for installation in hazardous locations. Figure 4-16 shows typical conductor terminations.

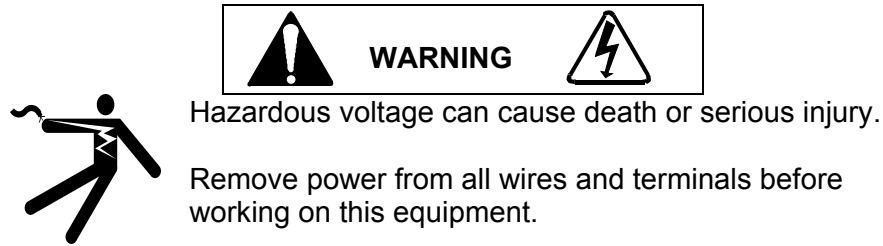

CAUTION

Use supply wires suitable for 5°C (10°F) above ambient temperature.

Before wiring the loop, the following should already have been completed:

- Selection of either analog or digital operating mode and corresponding Point-to-Point or Multi-Drop network; Section 4.3.4.
- Selection of a power supply; Section 4.3.5.
- Mechanical installation of transmitter(s) installed; Section 4.4.
- Pulling of loop cable through conduit and into terminal compartment; Section 4.5.3.

To connect the transmitter to the loop, perform the following steps.

1. Remove power from all involved wires and terminals.
2. Access the transmitter signal terminals by removing the enclosure cap nearest to the electrical entrance. Turn the cap counterclockwise.
3. Determine method of connection to transmitter signal terminals; see Figure 4-16 for typical connection methods.
4. Strip loop cable and conductors. Install ring tongue or spring spade terminals for #8 screws and the cable conductor gauge. If terminals will not be used, tin conductor ends and form a loop.
5. Connect the loop cable to the LOOP (+) and (-) terminals inside the transmitter's enclosure. Refer to Figures 4-6 through 4-9 for the needed connections for the type of network. Terminals will accommodate wire sizes up to 16 AWG (1.3 mm²).
6. Install the enclosure cap by turning it clockwise until the O-ring contacts the enclosure, Tighten the cap one additional turn to compress the O-ring.
7. If one of the two electrical conduit entrances in the housing is not used, it should be plugged. Refer to the transmitter's rating plate and Section 9 to determine whether entrance holes accept 1/2-NPT or M20 x 1.5 fittings.

Seal 1/2-NPT fitting with Teflon tape; seal M20 fitting with a soft setting sealing compound rated for at least 105°C (221°F).

8. Ground the enclosure by installing a 16 AWG (1.3 mm²) or larger copper wire between the enclosure ground screw and a low resistance ground, such as a nearby metal cold water pipe.

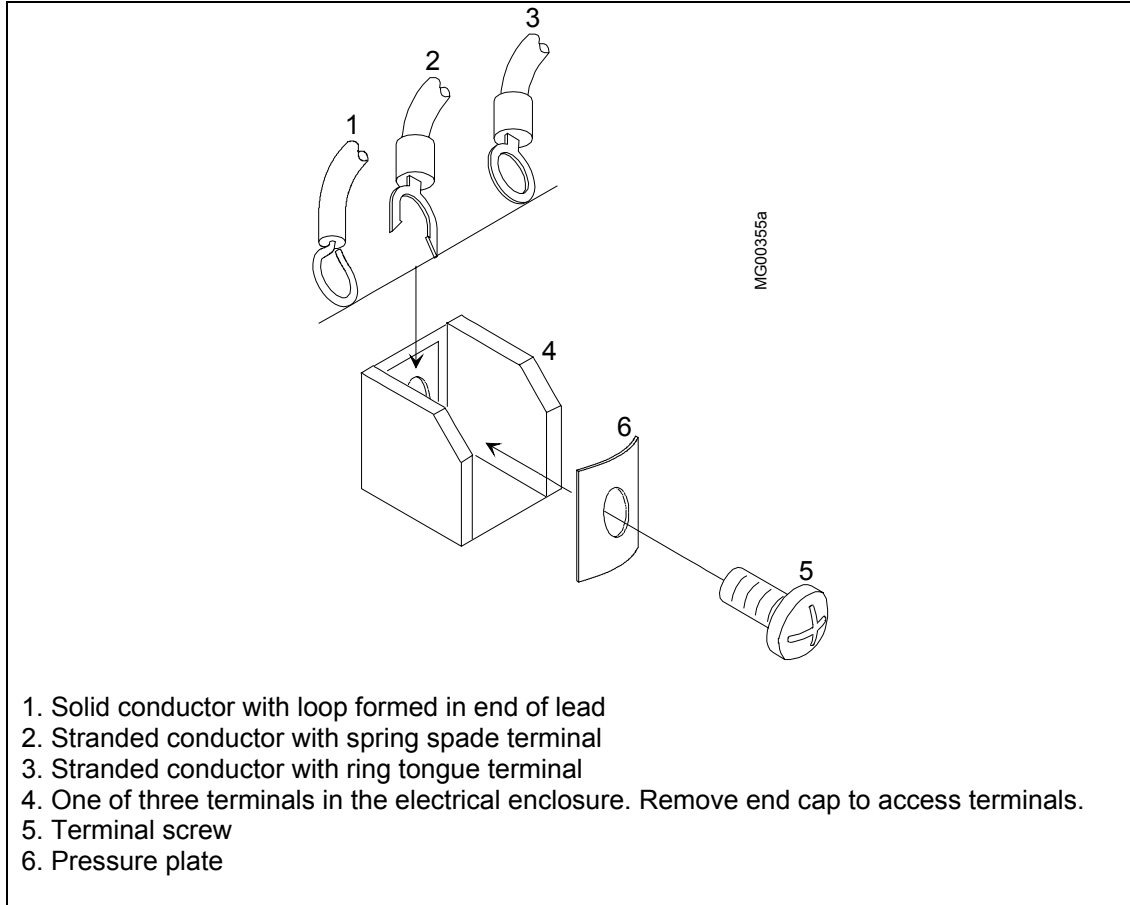

FIGURE 4-16 Network Conductor Terminations

4.7 HAZARDOUS AREA INSTALLATION

Drawings providing transmitter installation data for hazardous areas are located in Appendix B Hazardous Area Installation. Entity parameters, barrier selection, and important wiring information are specified on these drawings. The appendix also contains a list of tested barriers.



Explosion can cause death or serious injury.

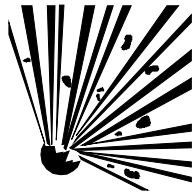

In a Division 1 area, where an explosion-proof rating is required, remove power from the transmitter before removing either enclosure cap. When replacing an enclosure cap, it must be screwed onto the enclosure until the O-ring is sufficiently compressed to prevent leakage into the enclosure. Cap locks may be required.

All pertinent regulations regarding installation in a hazardous area must be observed.

Before installing a transmitter in a hazardous area, check the rating and approval plates on the transmitter and Section 9 Model Designation and Specifications for required approvals or certifications.

Explosion-Proof Installation

If the installation is required to be explosion-proof as defined by the National Electrical Code, refer to a current copy of the Code and the following:

- User-supplied explosion-proof conduit seals (glands) are required on transmitter housing conduit outlets and any installed junction boxes. See Figure 4-15.
- Explosion-proof glands must provide a good seal. Apply a sealing compound around the sealing surface if necessary.
- Power wiring conduit entries at the transmitter must have a minimum of five threads fully engaged.
- The enclosure cap must be installed and have a minimum of eight threads fully engaged with no damaged threads permitted.
- Go to Section 4.6 for wiring connections to the transmitter's terminals. Refer to Appendix B for hazardous area installation.

This completes the physical installation.



5.0 POST-INSTALLATION TEST

This section provides guidelines for performing a post-installation test or commissioning. These steps include:

- Performing an installation review to verify that the proper transmitter is installed and that it is installed correctly. See Section 5.2.
- Testing HART communications and performing a transmitter self test. Exercising the transmitter over its configured range and checking analog output accuracy. See Sections 5.3 and 5.4.
- Adjusting shutoff valves to set transmitter zero and prepare for on-line operation with live process pressures. See Section 5.5.



Explosion can cause death or serious injury.

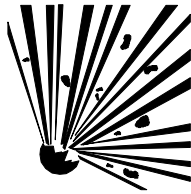

Only a certified ammeter may be used in intrinsically safe circuits.

In a Division 1 area, where an explosion-proof rating is required, remove power from the transmitter before removing either enclosure cap.

If a pre-installation test of the transmitter was not performed, review Section 3 Pre-Installation Test as the described tests can be performed after installation.

5.1 TEST EQUIPMENT

- User configuration data for the transmitter(s)
- HART Communicator (see Section 2 of this manual)
- Laboratory grade digital multimeter (DMM); for calibrating the 4 to 20 mA output signal; a meter certified for use in intrinsically safe circuits must be used in an intrinsically safe installation

Voltmeter Section	Accuracy $\pm 0.01\%$ of reading
	Resolution 1.0 mV
	Input impedance 10 M Ω
Ammeter Section	Accuracy $\pm 0.1\%$ of reading
	Resolution $\pm 1 \mu\text{A}$
	Shunt resistance 15 Ω or less

5.2 INSTALLATION REVIEW

1. To ensure the correct transmitter model has been installed, note the model designation and certifications on the transmitter's rating and approval plates. Compare this information to the model specified in user's documentation (P&I drawing).

Refer to Section 9 Model Designations and Specifications to confirm that the correct model with the correct certifications has been installed. Confirm that any needed hazardous area barriers have been installed and that all other installation requirements have been met.

2. Check that the transmitter is securely mounted. Check transmitter piping. Be sure that all needed shutoff valves and related equipment have been installed.
3. Check all wiring for correct and secure connection. Refer to Section 4 Installation and to user's documentation for wiring diagrams.
4. Check wire runs to be sure that wires are protected from abrasion or other damage, correctly supported, and physically separated from other signal or power wiring that may cause interference.
5. Check that a current sense resistor of the correct value has been installed.
6. Apply power to the power supply or other loop power source (e.g., controller). Use the DMM to check power supply output voltage. Note that the transmitter is on whenever power is applied.

5.3 EQUIPMENT CONNECTION

1. Connect the equipment as shown in Section 4 Installation, in the user's documentation, or as shown below. The HART Communicator is a non-polar device.
2. Set the DMM to read 4-20 mA.

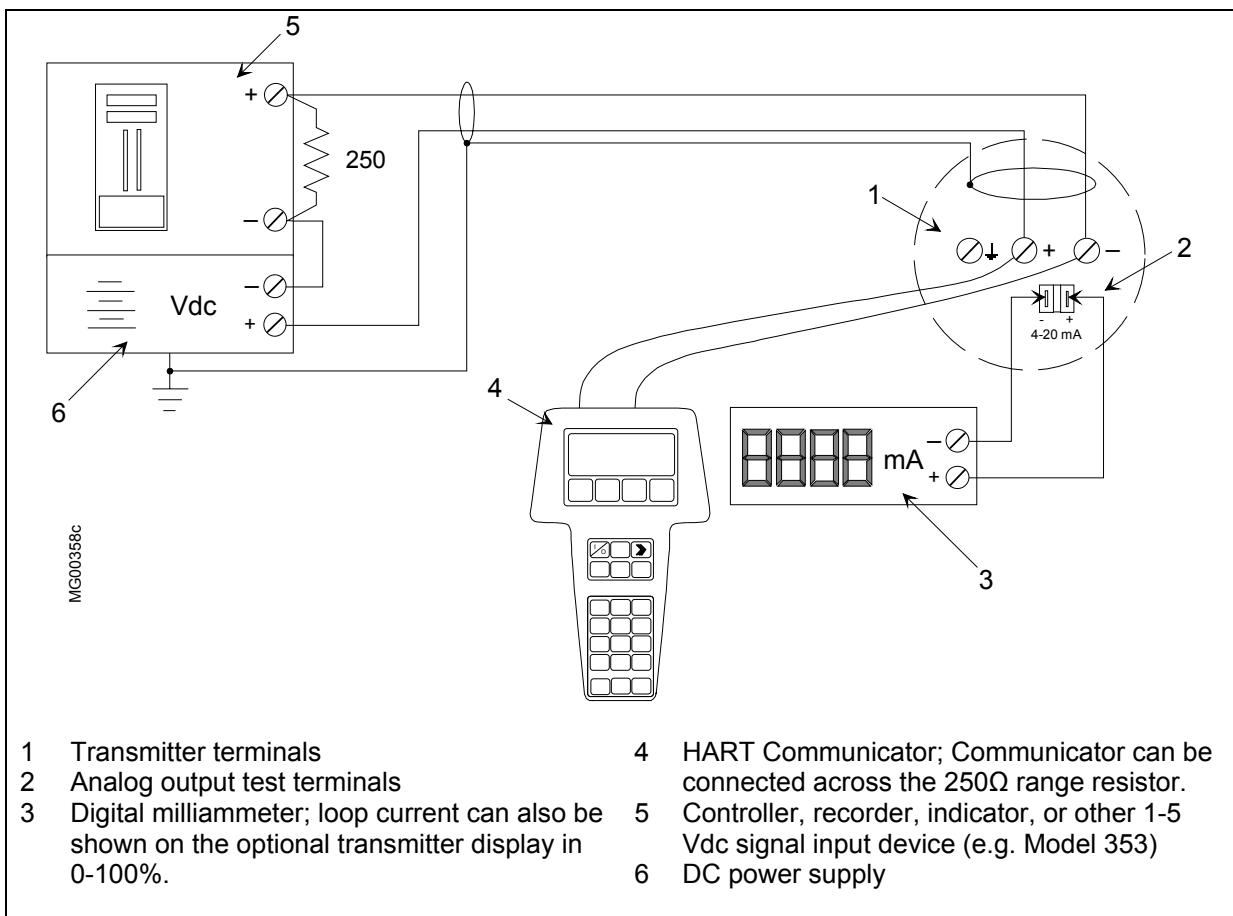

FIGURE 5-1 Equipment Connection for System Checkout

5.4 VERIFICATION

This section describes the communication test, communication error check, analog output verification, and configuration verification. It also contains subsections that involve manipulation of the process pressures applied to the transmitter.

5.4.1 Communication Test

This test verifies that the HART Communicator and transmitter(s) can communicate properly. From user configuration documentation, obtain transmitter IDs, addresses, and tags.

1. Turn on the HART Communicator by pressing the I/O key.
 - If the Communicator finds a transmitter on a Point-To-Point Network, the Online menu with the transmitter's type and tag name is displayed. Go to Section 5.4.2.
 - If the Communicator displays: `No device found at address 0. Poll?`, go to either step 2 or 3, depending upon the type of network installed.

2. POINT-TO-POINT NETWORK

Check the following: Communicator connections, all other loop connections, power to transmitter, transmitter address (0), transmitter model number. Repair as necessary and repeat step 1.

3. MULTI-DROP NETWORK

Press Yes (F1) to enter digital mode and search for devices with polling addresses of 1-15.

- If the Communicator finds a transmitter on a Multi-Drop Network, the Online menu with the transmitter's type and tag name is displayed. Each transmitter connected to the loop can be interrogated in sequence. Go to the next Section.
- If the Communicator displays: `No device found. Press OK`, check all loop connections, power to transmitters, transmitter addresses (1-15), transmitter model numbers, etc. Repair as necessary and repeat step 1.

5.4.2 Transmitter Selftest

To test the transmitter's electronics, perform the following:

1. Establish communication; the Online menu displays. In the Online menu, Press 3 Device Setup.
2. In sequence, press 2 Diagnostics/Service, 2 Simulation/Test, 2 Test and finally 1 Selftest.
3. The message Selftest OK will be shown when the transmitter passes its selftest. If it does not pass, an error message will be shown.
 - If the transmitter passes, go to Section 5.4.3.
 - If an error message is displayed, troubleshoot as necessary. Refer to Section 7 Calibration and Maintenance as needed.

5.4.3 Loop Test

This test verifies that a transmitter is operating properly and is capable of transmitting 0% and 100% analog output signals to a HART Master. The test applies only to transmitters operating in analog mode. A transmitter configured for digital mode can be tested by setting its address to zero (0).

1. Establish communication; the Online menu displays. First, press 3 Device Setup, then 2 Diagnostics/Service, 2 Simulation/Test, 1 Simulation, and finally 1 Loop Test.
2. A warning appears: “WARN–Loop should be removed from automatic control.” If the loop status cannot be changed for operational reasons, press ABORT (F3) to end this procedure and return to the Online menu. If it is okay to proceed, go to step 3.
3. Remove the loop from automatic control, then press OK (F4). When OK is pressed, a list of analog output options is displayed (at right).
4. Press “1” on the keypad or ENTER (F4) to select the 4 mA option. The Communicator displays the message “Fld dev output is fixed at 4.000 mA.” Press OK (F4) to confirm and proceed with testing or press ABORT (F3) and proceed to step 8.
5. Read the DMM. The value should be 4 mA.
6. Repeat steps 4 and 5 using the 20 mA output level. The DMM reading should be 20 mA.
7. For outputs other than 4 or 20 mA, choose option 3, Other, and enter any desired output value. The DMM reading should be the entered value in mA.
8. To end the loop override session, press “4” on the keypad or the ABORT (F3) softkey. The message “Returning fld dev to original output” appears.
9. When the message “NOTE–Loop may be returned to automatic control” appears, return the loop to automatic control, then press OK (F4). This completes verification of analog output.

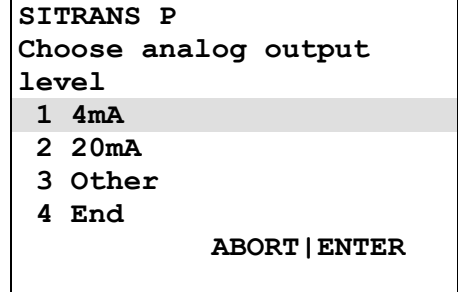

Note: If using a Model 375 Field Communicator, see the inside of the front cover of this manual.

Important

Failure to exit loop override correctly can cause the transmitter to remain parked at a fixed current.

5.5 TRANSMITTER ZERO AND SHUTOFF VALVE MANIPULATION

This section describes setting transmitter zero and adjusting shutoff valves for use with live process pressures. The following commissioning cases are typical examples. Different arrangements may be advisable depending on the system configuration.



Improper operation of the valves can result in serious injury or considerable material damage.

Read and understand the complete procedure before starting a post-installation test.

5.5.1 Absolute Pressure

Absolute pressure transmitters with gauge construction or with differential construction can be commissioned using the following methods.



Process material can be hazardous to people and harmful to equipment.

Be sure all process connections are firm and tight. When using a male thread G 1/2 A and installing in zone 0, a flat metal seal e.g. DIN 16258 must be used. The width of the seal (material strength) must be at least 3 mm.

5.5.1.1 Measuring Gases

Operate the shutoff fittings as described below. Refer to Figure 5-2 to identify the valve being manipulated.

1. Close all valves.
2. Open the test connection shutoff valve (2B).
3. Apply to the transmitter, through the test connection shutoff fitting (2), a pressure corresponding to zero.
4. Check zero and correct if necessary.
5. Close the test connection shutoff valve (2B).
6. Open the shutoff valve (4) on the pressure tap.
7. Open process shutoff valve 2A.

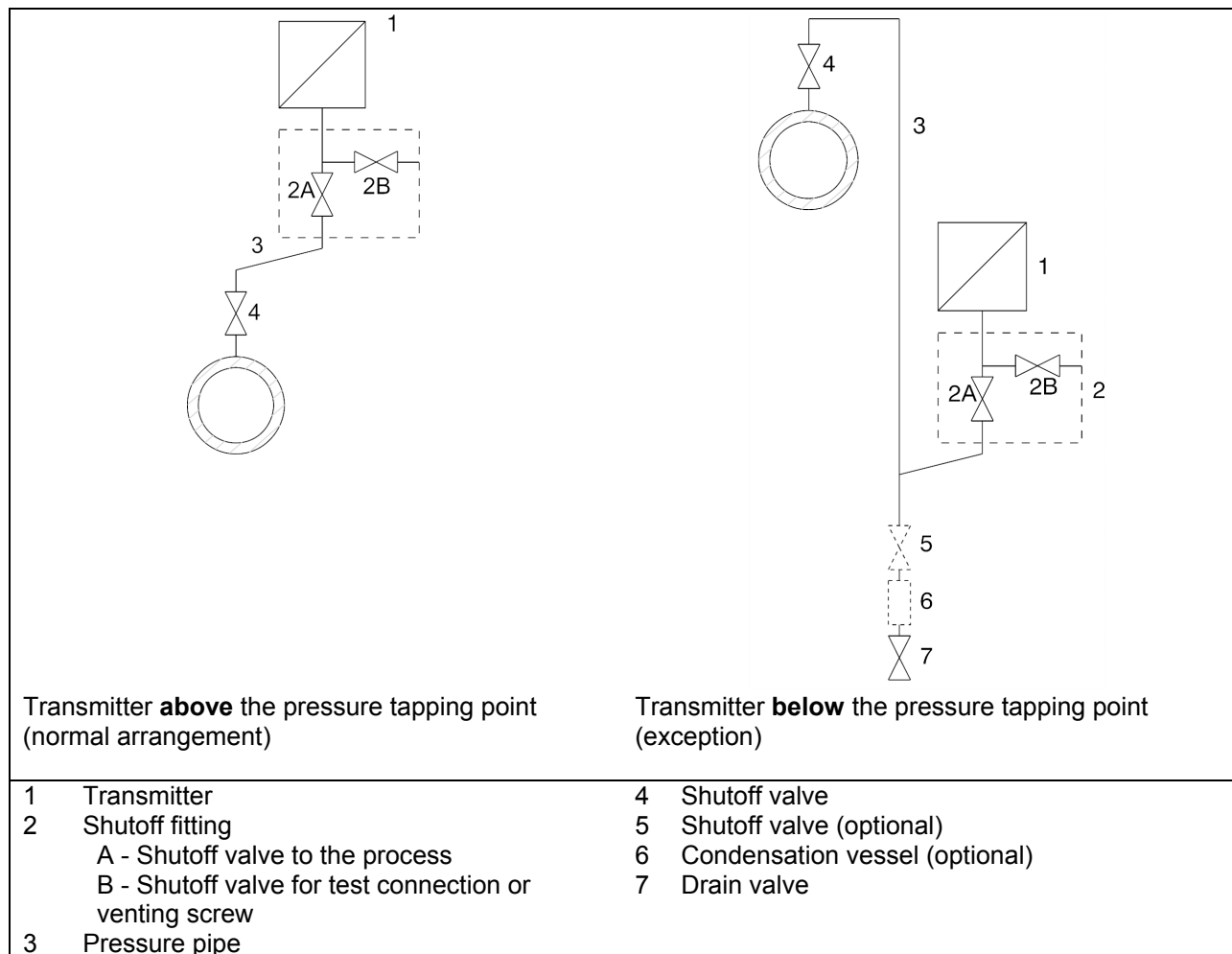

FIGURE 5-2 Measuring Gases

5.5.1.2 Measuring Vapor and Liquid

Operate the shutoff valves in the following order. Refer to Figure 5-3 to identify the valves used in the procedure.

1. Close all valves.
2. Open shutoff valve 2B.
3. Apply to the transmitter, through the test connection shutoff fitting (2), a pressure corresponding to zero.
4. Check zero and correct if necessary.
5. Close shutoff valve 2B.
6. Open shutoff valve (4) on the pressure tap.
7. Open process shutoff valve 2A.

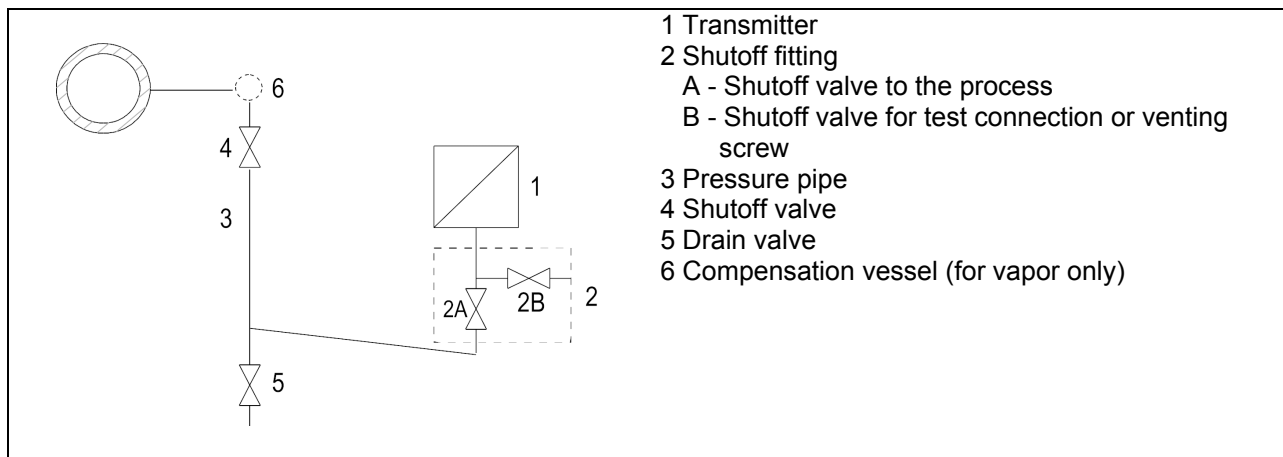

FIGURE 5-3 Measuring Vapor and Liquid

5.5.2 Differential Pressure and Flow

Differential pressure and flow transmitters can be commissioned using the following methods.



Process material can be hazardous to people and harmful to equipment. Serious injury or considerable material damage may result if:

- the vent valve and/or the sealing screw are missing or are not sufficiently tight.
- the valves are operated wrongly or improperly.

In the case of hot process liquid or gas, the individual operating steps must be performed in rapid succession. Otherwise, the valves and the transmitter may be over heated leading to damage.

5.5.2.1 Measuring Gases

Operate the shutoff valves in the following order. Refer to Figure 5-4 to identify the valves used in the procedure.

1. Close all valves.
2. Open both shutoff valves (5) at the pressure taps.
3. Open the compensation valve (2).
4. Open one active pressure valve (3A or 3B).
5. Check and correct zero (4 mA) if necessary at zero mbar.
6. Close the compensation valve (2).
7. Open the other active pressure valve (3A or 3B).

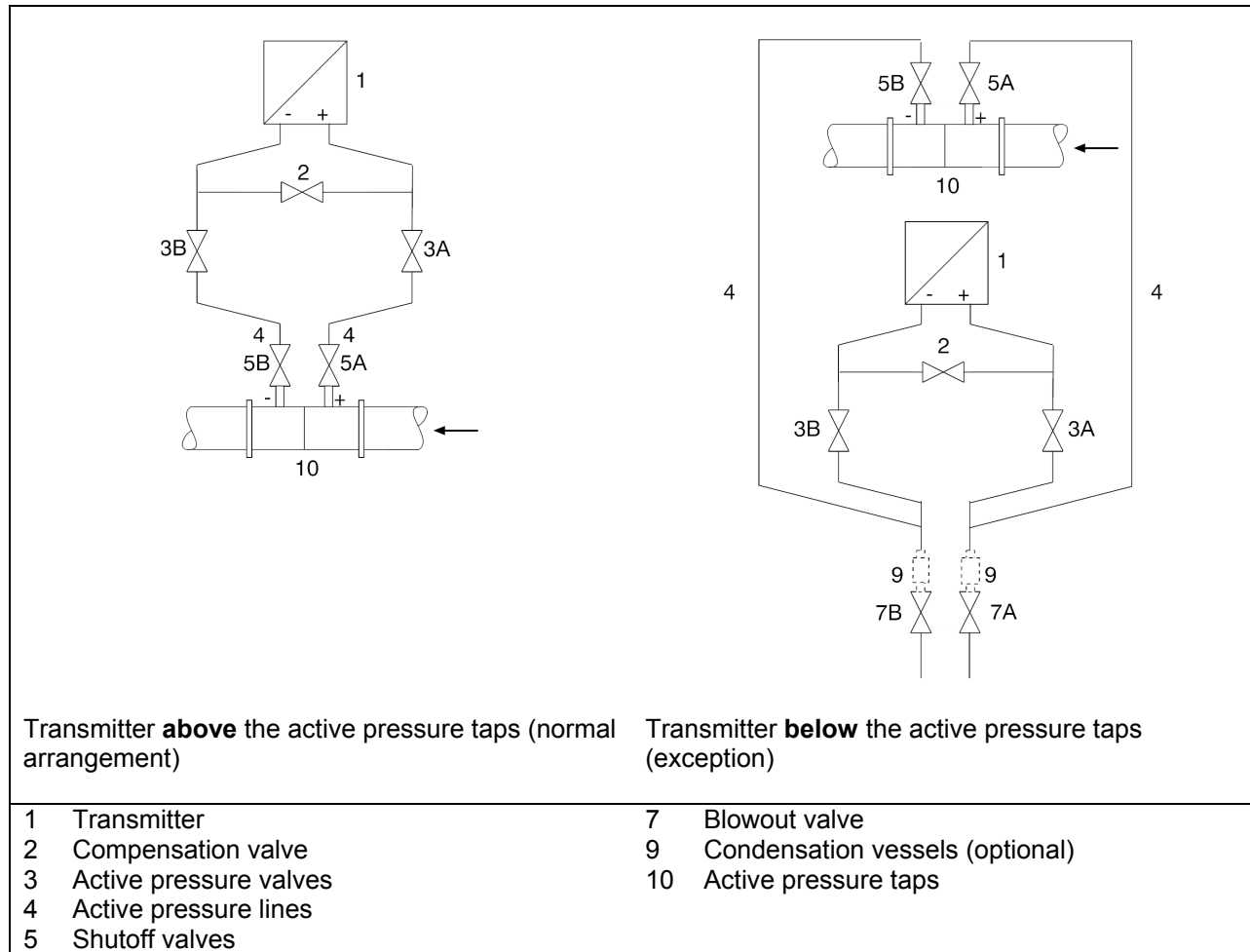

FIGURE 5-4 Measuring Gases

5.5.2.2 Measuring Liquids

Operate the shutoff valves in the following order. Refer to Figure 5-5 to identify the valves used in the procedure.

1. Close all valves.
2. Open both shutoff valves (5) at the pressure taps.
3. Perform one of the following depending upon transmitter location:
 - “Transmitter **below** the active pressure tap” - Open both blowout valves (7) one after the other.
 - “Transmitter **above** the active pressure tap” - Open both vent valves (8) slightly until air-free liquid emerges.
4. Close both blowout valves (7) or vent valves (8).
5. Open the active pressure valve (3A) and the vent valve at the high-pressure chamber of the transmitter (1) slightly until air-free liquid emerges.
6. Close the vent valve.
7. Open the vent valve at the low-pressure chamber of the transmitter (1) slightly until air-free liquid emerges.

8. Close the active pressure valve (2).
9. Open the active pressure valve (3B) slightly until air-free liquid emerges, then close it.
10. Close the vent valve at the low-pressure chamber (1).
11. Open the active pressure valve (3A) by 1/2 turn.
12. Check and correct zero (4 mA) if necessary at zero bar.
13. Close the compensation valve (2).
14. Open the active pressure valves (3A and 3B) fully.

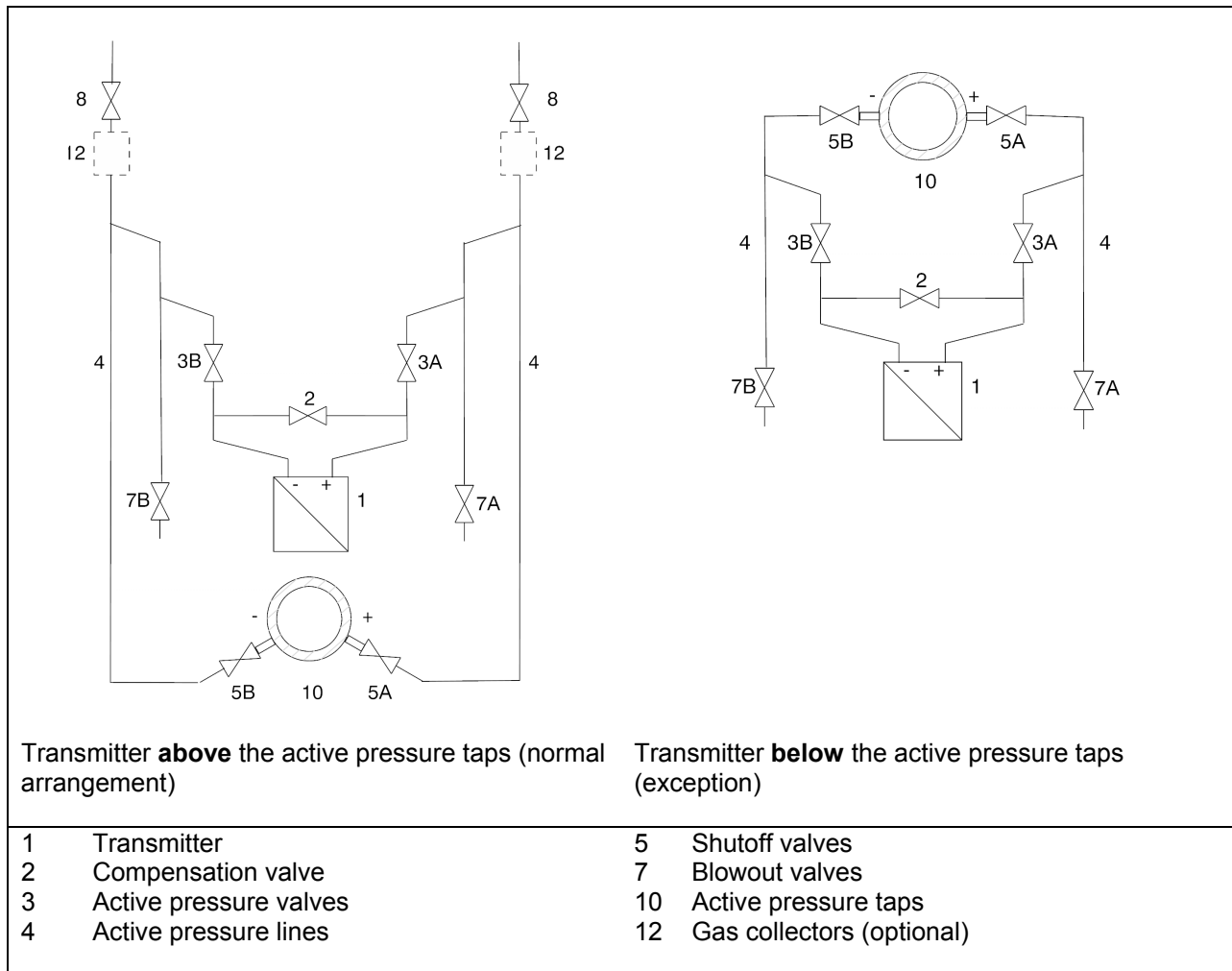

FIGURE 5-5 Measuring Liquids

5.5.3 Measuring Vapor

Operate the shutoff valves in the following order. Refer to Figure 5-6 to identify the valves used in the procedure.

Caution

The measuring result is error-free only when the active pressure lines (4) contain equal columns of condensate that are at the same temperature. Repeat the zero adjustment when these conditions are satisfied.

If the compensation valve (2) is opened when the shutoff valves (5) and active pressure valves (3) are both open, the transmitter (1) may be damaged by flowing vapors.

1. Open both shutoff valves (5) at the pressure taps.
2. Open the compensation valve (2).
3. Wait until the vapor in the active pressure lines (4) and in the compensation vessels (13) has condensed.
4. Open the active pressure valve (3A) and the vent valve at the high-pressure chamber of the transmitter (1) slightly until air-free condensate emerges.
5. Close the vent valve.
6. Open the vent valve at the low-pressure chamber of the transmitter (1) slightly until air-free condensate emerges.
7. Close the active pressure valve (3A).

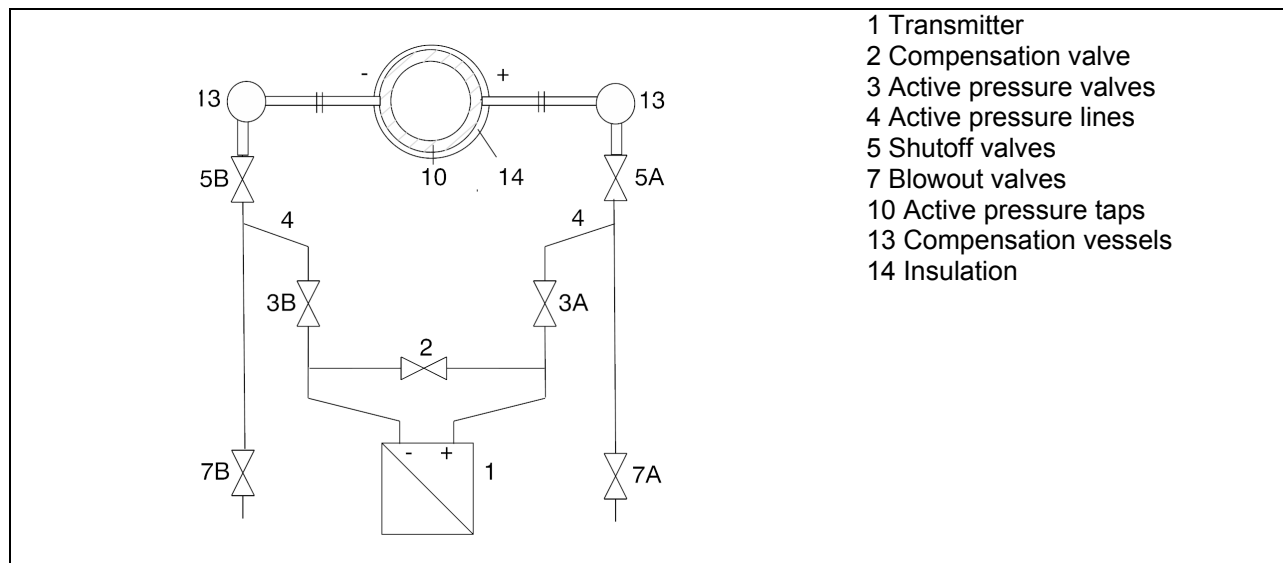

FIGURE 5-6 Measuring Vapor

8. Open the active pressure valve (3B) slightly until air-free condensate emerges, then close it.
9. Close the vent valve at the low-pressure chamber (1).

10. Open the active pressure valve (3A) by 1/2 turn.
11. Check and correct zero (4 mA) if necessary at zero bar.
12. Close the compensation valve (2).
13. Open the active pressure valves (3A and 3B) fully.

This completes the post-installation testing. Disconnect test equipment, connect any disconnected wires, and restore any removed protective covers on the transmitter or other devices.



6.0 ON-LINE CONFIGURATION AND OPERATION

A transmitter is shipped with default data in its memory. Some of this data controls communication and transmitter operation and cannot be altered. Other data is used by the transmitter to respond to changes in pressure with a change in output current or HART digital output and is alterable by the user. This data includes configuration parameters that set up the transmitter for use in a specific process environment.

On-line operation includes local configuration using the magnetic pushbuttons on the transmitter enclosure and remote configuration and monitoring involving communication between the HART Communicator (host device) and transmitter.

There are four major subsections. Section 6.1 introduces the local digital display and the local magnetic pushbuttons. Section 6.2 provides details about configuring and using the transmitter locally; the optional display must be installed. Section 6.3 describes use of a transmitter that does not have a display. Finally, Section 6.4 provides the steps to configure and monitor a transmitter from a HART Communicator.

6.1 LOCAL OPERATION AND DISPLAY

Local configuration and operation make use of built-in magnetic pushbuttons and an optional digital display. As shown in the adjacent figure, the display (1) is behind the enclosure cap. The magnetic pushbuttons are under the hinged cover (2).

There are three magnetic pushbuttons or keys:

M = Mode Select

↑ = Increase

↓ = Decrease

Use the display and the magnetic pushbuttons as described in this section.

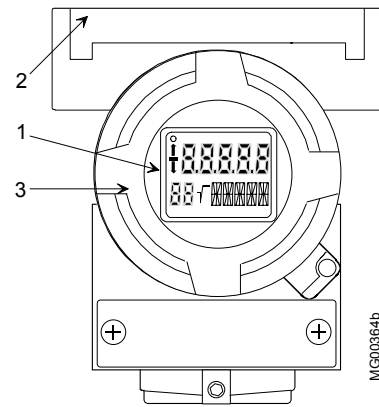

- 1 Optional digital display
- 2 Magnetic pushbutton (keyboard) access cover
- 3 Enclosure cap

6.1.1 Digital Display

The local display can show the measured value and engineering unit, sign, status, mode, and output current; see Figure 6-1. The root sign appears when a square root characteristic is used for differential pressure or flow. HART communications is indicated by flashing of the communication indicator.

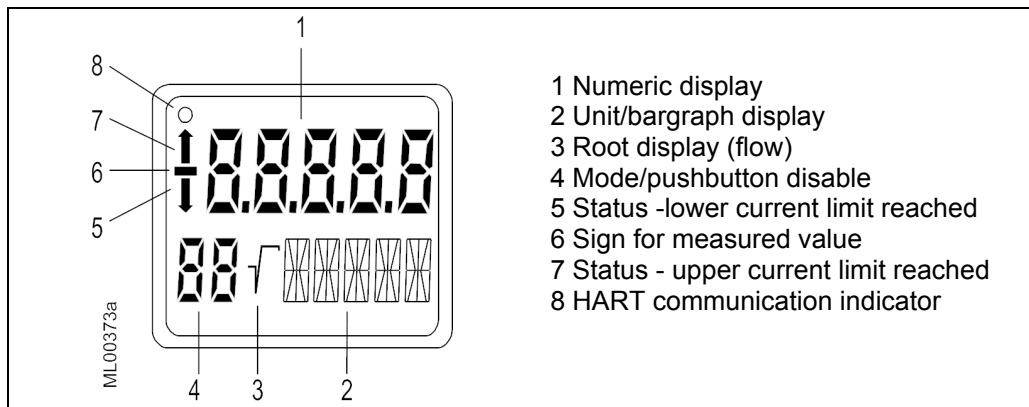

FIGURE 6-1 Digital Display

6.1.2 Numeric Display

The 5-digit numeric display can be configured to show one of the following.

- Transmitter current output (4-20 mA or %, selection shown in the unit/bargraph display)
- Pressure value, in percent, relative to the set range
- Measured value in a selectable engineering unit (shown on the unit/bargraph display)

Sign for the Measured Value

When the measured value is a negative number, the minus sign is lighted.

Status Arrows

Table 6-1 shows the modes in which the status arrows are active, as well as the meaning of each arrow for each mode.

TABLE 6-1 Operating Mode and Status Arrows

Operating Mode ¹	Status ↑ (Display)	Status ↓ (Display)
Mode 2 (set zero ²)	Upper current limit exceeded	Lower current limit exceeded
Mode 3 (set full scale ³)	Upper current limit exceeded	Lower current limit exceeded
Mode 4 (set damping)	Upper damping value exceeded	Lower damping value exceeded
Mode 5 (set zero blind ²)	Upper sensor limit exceeded	Lower sensor limit exceeded
Mode 6 (set full scale blind ³)	Upper sensor limit exceeded	Lower sensor limit exceeded.
Mode 7 (set zero position correction)	Maximum span exceeded by more than 5%	-----
Mode 12 (set root switch point)	Square root switch point exceeded by more than 15%	Dropped 5% below the square root switch point
Magnetic Pushbutton Operation (Mode 2, 3, 5, or 6)	Span to be set exceeds the maximum span	Span to be set is less than the minimum span
Normal Operation	Output current exceeds the upper saturation limit or Input pressure exceeds the upper sensor limit	Output current is below the lower saturation limit or Input pressure is below the lower sensor limit

¹ Operating Mode selected by pressing the M pushbutton.

² p_{min} = minimum operating input pressure; ³ p_{max} = maximum operating input pressure

Communication Indicator

○ = HART communication is active when the circle is flashing.

6.1.3 Unit/Bargraph Display

This alphanumeric display has five 14-segment fields in the lower right quadrant of the display; see below. It shows the selected engineering unit as a percentage, engineering unit, or current value. If desired, a bargraph which represents the percentage pressure value in the range from 0-100% can alternate with the engineering unit. The bargraph function is turned off in the default setting.

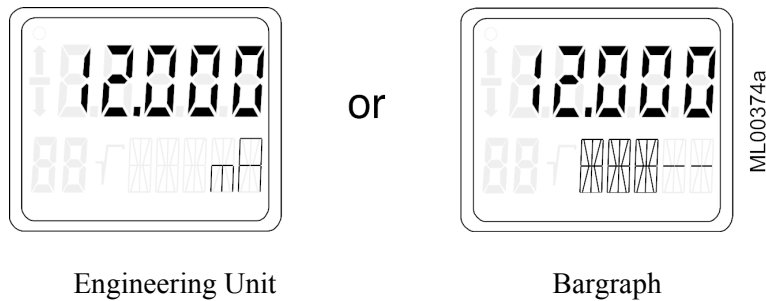

The unit/bargraph display is also used to display a scrolling error, warning, or alarm message.

6.1.4 Error Message

The message “Error” will be displayed in the Numeric display should a transmitter hardware or software problem occur. A message describing the error will scroll horizontally through the unit/bargraph display. This information is also available at the HART Communicator.

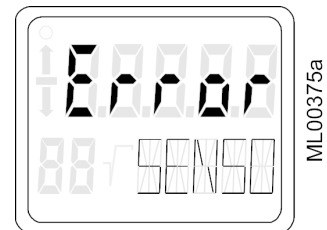

6.1.5 Output Signal Range

The output signal is divided into defined areas.

The transmitter converts the measured pressure into an output current that is normally in the range of 4-20 mA.

Measured values below and above the range limits are also displayed. The UNDER message or OVER message for the selected unit appears alternately in place of the engineering unit or bargraph. The overflow range, shown in the following figure, can be set using the HART Communicator. When an upper or lower range limit is exceeded, the output current remains linear and a status arrow appears on the transmitter display; see Table 6-1.

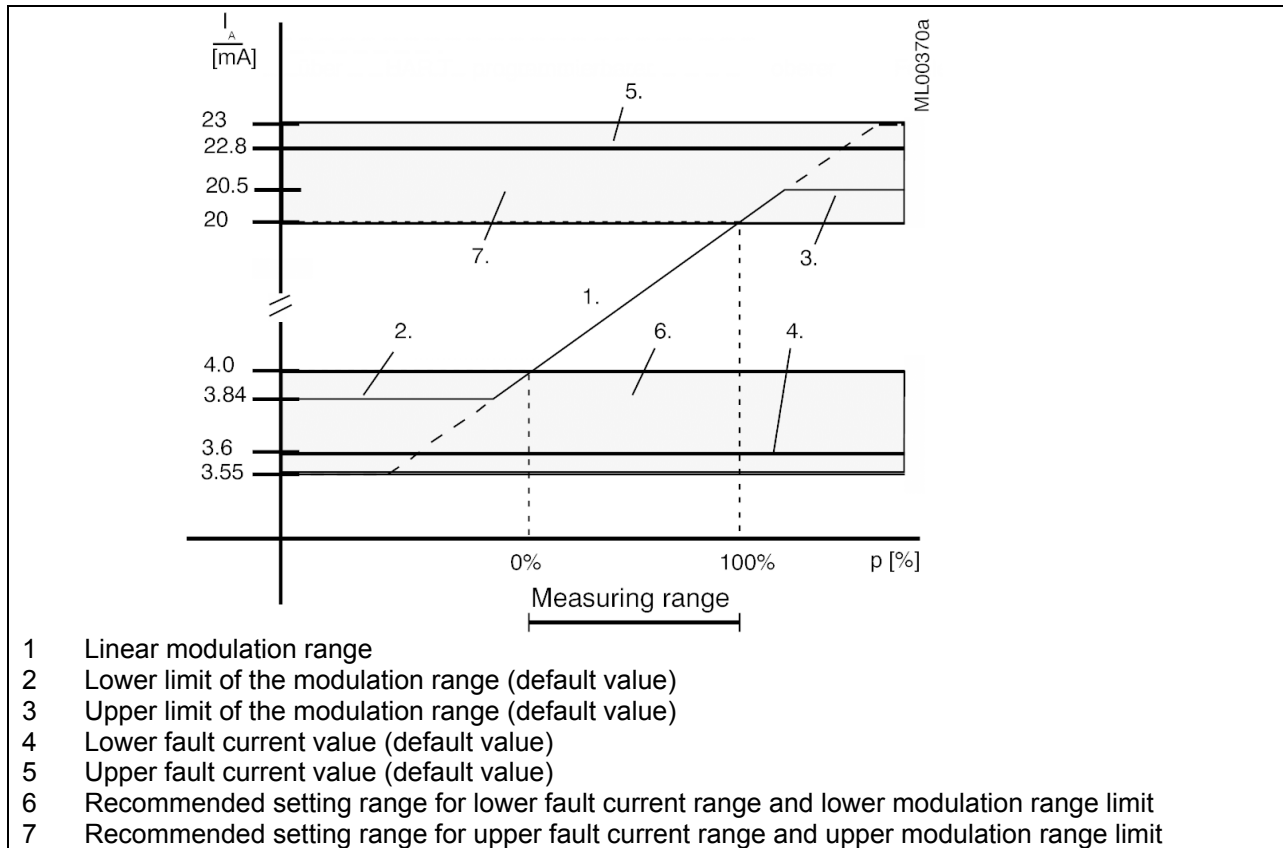

6.1.6 Mode Display

An operating mode is selected by pressing the M pushbutton. The selected mode is shown in the lower left quadrant of the digital display. In the example at right, mode 4 Electric Damping has been selected and a damping value of 0.2 has been set.

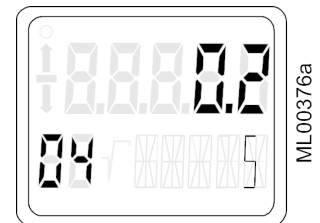

6.2 LOCAL OPERATION WITH THE MAGNETIC PUSHBUTTONS

The transmitter can be configured locally using the magnetic pushbuttons, shown below. Table 6-2 shows the operating modes and configuration parameters accessed by pressing the M pushbutton. These configuration parameters are also available using the HART Communicator.

Note

A selected mode will time out after about 2 minutes of pushbutton inactivity and the displayed parameter value will be stored.

A polling address of zero (0) must be stored for the magnetic pushbuttons to function. The magnetic pushbuttons will be disabled if a polling address of 1-15 has been stored, as indicated by a C in the lower left quadrant of the display.

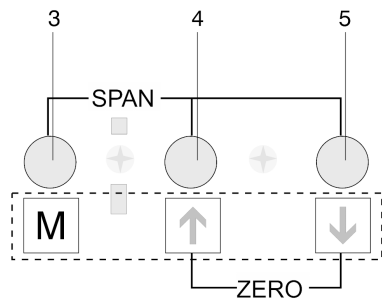

- 1 Digital display
- 2 Connector
- 3 Mode key
- 4 Increase key
- 5 Decrease key

ML00377a

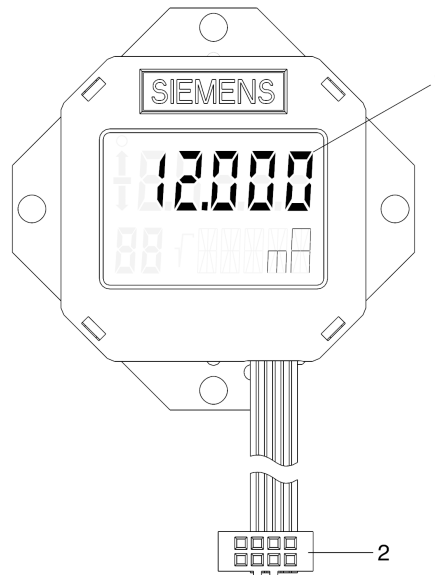

TABLE 6-2 Parameters Accessible Using the Magnetic Pushbuttons

Configuration Parameter	Mode M ¹	Increase/Decrease Pushbuttons (Keys)			Description	See Section
		↑ Increase	↓ Decrease	↑ and ↓ ³		
Measured value	---	---	---	---	Output current in mA or % or input pressure in selected engineering units	6.2.10
Error display	---	---	---	---	Error	6.2.7
Zero	2	Increase current	Decrease current	Set to 4 mA	Output current in mA	6.2.2
Full scale	3	Increase current	Decrease current	Set to 20 mA	Output current in mA	6.2.2
Electric damping	4	Increase damping	Decrease damping	---	Range 0.0 to 100.0 seconds	6.2.3
Zero “blind setting”	5	Increase pressure	Decrease pressure	Set to start of scale 0	Zero in the selected engineering unit	6.2.4
Full scale “blind setting”	6	Increase pressure	Decrease pressure	Set to upper measuring limit	Full scale in the selected engineering unit	6.2.4
Zero for position correction ²	7	---	---	Press both pushbuttons simultaneously	Re-zero when oriented from vertical	6.2.5
Output Current	8	Increase current	Decrease current	Switch on/off	Constant output current	6.2.6
Failsafe output current	9	---	---	Select	Failsafe output current; limits set by user	6.2.7
Pushbutton enable/disable	10	---	---	Select	0 = None LA = All disabled LO = All disabled except zero LS = All disabled except zero and full scale L = Write protect; HART operation disabled	6.2.8
Characteristic, DP only	11	---	---	Select	lin = linear srln = square root (linear to switch point) sroff = square root (switched off up to switch point)	6.2.9
Set square root switch point	12	Increase	Decrease	---	Parameter range 5 to 15% of flow	6.2.9
Measured value display	13	---	---	Select	Unit of pressure (input value) or output current in either mA or 0-100%	6.2.10
Unit of pressure	14	---	---	Select	See Figure 6-3 for engineering units	6.2.11

Notes:

1. Press the M pushbutton to change the mode.
 2. IMPORTANT: Absolute pressure transmitters - the zero is established in a vacuum! A zero adjustment to a ventilated absolute transmitter will cause an error!
 3. Press both pushbuttons simultaneously.
- DP = differential pressure

6.2.1 Cancel Pushbutton Disable and Write Protection

A pushbutton disable (LA, LO, LS, or L) can be entered locally or from the HART Communicator. To enable the pushbuttons, press and hold the M pushbutton for at least 5 seconds.

Another pushbutton disable (LL) can be entered from the Communicator. This disable must be canceled using HART. See Section 6.4.9 to cancel the LL disable.

6.2.2 Set/Adjust Zero and Full Scale

Zero and full scale can be set or adjusted from the magnetic pushbuttons. Modes 2 and 3 provide access. Both forward and reverse acting characteristics are accommodated.

6.2.2.1 Theoretical Relationships

Setting Zero and Full Scale

First, specify the desired zero and full scale analog output currents, typically 4 mA and 20 mA respectively. Operating process pressures are then specified: p_{\min} and p_{\max} , for minimum and maximum operating pressures. When specifying these input pressures, always refer to the rating plate for model number, measuring span, and other performance related information.

Apply the input pressures and set the output currents using the local magnetic pushbuttons or the HART Communicator. Input pressures can be supplied by the process or by test equipment. Set zero first and then set full scale, since setting zero does not affect the span and setting full scale does not affect zero.

The relationship between the measured pressure and the resulting current output is linear, except when a square root output characteristic is selected. The output current for a linear relationship can be calculated using the following equation.

$$I = \frac{p - p_{\min}}{p_{\max} - p_{\min}} * 16 \text{ mA} + 4 \text{ mA}$$

I = output current
 p = input pressure for I
 p_{\min} = minimum operating input pressure (MA in leprello)
 p_{\max} = maximum operating input pressure (ME in leprello)

An example of the use of this equation is given below.

1. Given: a transmitter with a measuring range of 0 to 232 psi. The operating range is to be 29 to 203 psi.
2. Apply 29 psi to the transmitter. Press the M (mode) pushbutton to set the transmitter to mode 2. Set the zero by pressing the \uparrow and \downarrow pushbuttons simultaneously for about 2 seconds. An output current of 4 mA is then set.
3. Apply 203 psi. Press the M pushbutton to set the transmitter to mode 3. Set the full scale by pressing the \uparrow and \downarrow pushbuttons simultaneously for about 2 seconds. An output current of 20 mA is then set.
4. Calculate the output current for other input pressures. Apply the desired pressure and check the output current against the calculated value.

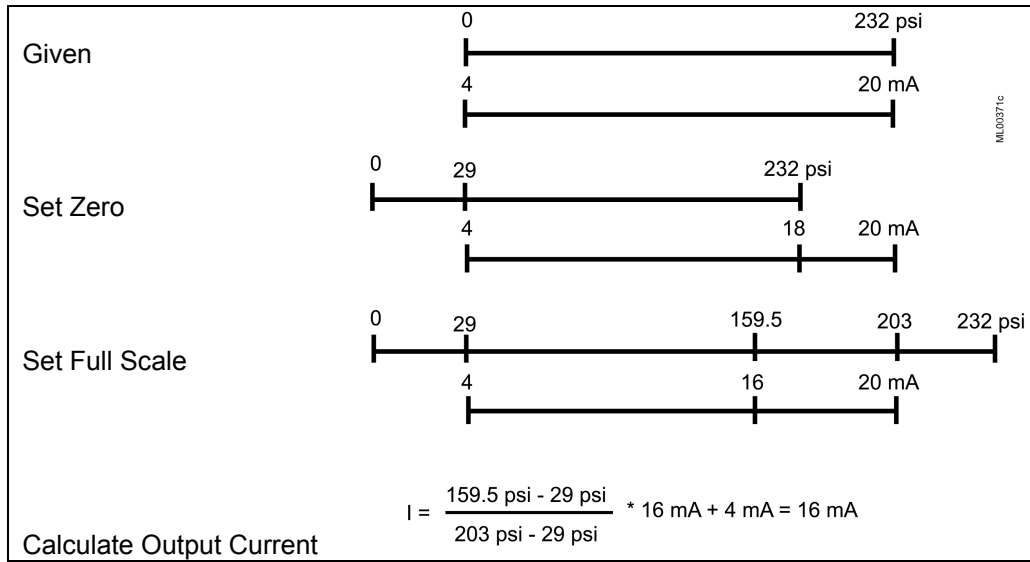

Adjusting Zero and Full Scale from a Single Reference

Zero and full scale can be adjusted to any desired current using only one reference pressure. This is particularly useful if the pressures necessary for zero and full scale are unavailable. Note that after the adjustment is completed, the measuring range on the rating plate may not match the new range.

Required to be known: The reference pressure, present zero value, and present full scale value.

Calculate the current to be set at p_{zn} using the first formula. Then calculate the current to be set at p_{fsn} using the second formula.

$$p_{zn} \quad I = \frac{p_{ref} - p_{zn}}{p_{fso} - p_{zo}} * 16 \text{ mA} + 4 \text{ mA}$$

I = output current

p_{ref} = applied reference pressure

p_{fso} = old full scale (ME_{act} in leporello)

p_{zo} = old start of scale (MA_{act} in leporello)

p_{fsn} = new full scale (ME_{nom} in leporello)

p_{zn} = new start of scale (MA_{nom} in leporello)

$$p_{fsn} \quad I = \frac{p_{ref} - p_{zn}}{p_{fsn} - p_{zn}} * 16 \text{ mA} + 4 \text{ mA}$$

An example of the use of these equations is given below. The figure following the example illustrates these steps.

1. Given: A transmitter with a measuring range of 0 to 160 psi. Change the span to 20 to 140 psi. A reference pressure of 110 psi is available.
2. Apply the reference pressure.
3. Calculate zero (20 psi) using the first formula.
4. Press the transmitter's M pushbutton to go the mode 2. Set the output current to 13 mA.
5. Calculate full scale (140 psi) using the second formula.
6. Press the transmitter's M pushbutton to go to mode 3. Set the output current to 16 mA.

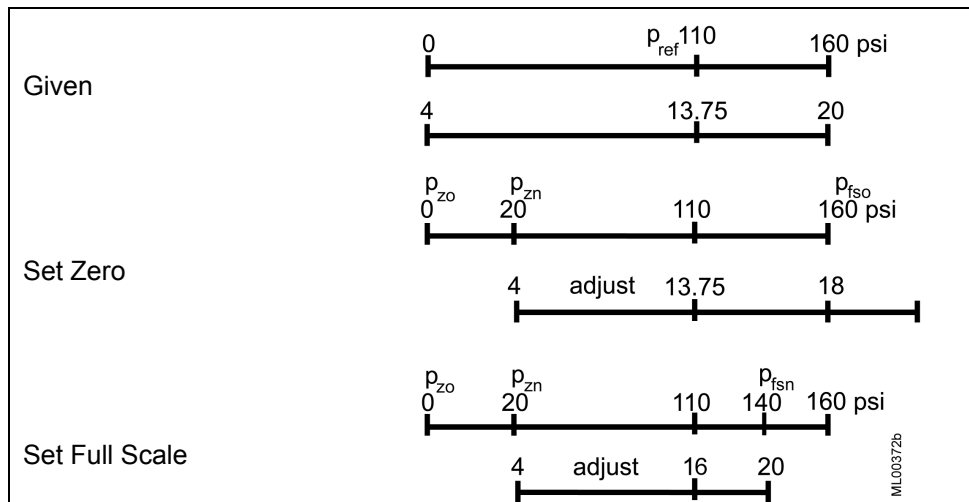

6.2.2.2 Practical Applications

Set Zero and Full Scale

The steps below should be followed to set the transmitter zero output current to 4 mA and the full scale current to 20 mA.

1. Apply a pressure representing zero.
2. Press the M pushbutton until mode 2 appears.
3. Set zero by pressing the \uparrow or \downarrow pushbutton to set the display to 4 mA.
4. Press the M pushbutton to save the setting and go to mode 3.
5. Apply a pressure representing full scale.
6. Set full scale by pressing the \uparrow or \downarrow pushbutton to set the full scale output current value in the display.
7. Press the M pushbutton to save the setting.

Adjust Zero and Full Scale

If only a single reference pressure is available, calculate the currents to be adjusted using the formulas and procedure in Section 6.2.2.1 subsection Adjusting Zero and Full Scale from a Single Reference.

1. If the transmitter does not have a display and an external milliammeter must be connected to read analog output current, remove the field terminals enclosure cap and connect the milliammeter.





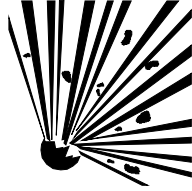

Explosion can cause death or serious injury.





Only a certified ammeter may be used in intrinsically safe circuits.

In a Division 1 area, where an explosion-proof rating is required, remove power from the transmitter before removing either enclosure cap.

2. Apply a known reference pressure.
3. Press the M pushbutton until mode 2 appears.
4. Set zero by pressing the  or  pushbutton.
5. Press the M pushbutton to save the setting and go to mode 3.
6. Set full scale by pressing the  or  pushbutton.
7. Press the M pushbutton to save the setting.

6.2.3 Electric Damping

Set the electronic damping time constant to between 0-100 seconds, in steps of 0.1 seconds, using the magnetic pushbuttons.



1. Press the M pushbutton until mode 4 appears.
2. Press the  or  pushbutton to set the damping to the desired value.
3. Save the setting by pressing the M pushbutton.

6.2.4 Blind Setting of Zero and Full Scale

Modes 5 and 6 are used to set or adjust zero and full scale respectively with no input pressure applied to the transmitter. It is also possible to change between forward acting and reverse acting characteristics here.

6.2.4.1 Theoretical Relationships

To adjust zero and full scale:

1. Select the desired engineering unit.
2. Select mode 5 and press and press the  or  pushbutton to adjust the lower pressure value that is to be equivalent to a 4 mA output. (Note that the pressure adjustment will not go below zero even if the lower sensor limit (LSL) is below zero.)

3. Select mode 6 and press the \uparrow or \downarrow pushbutton adjust the upper pressure value that is to be equivalent to a 20 mA output. (The assumed pressure will be the upper sensor limit.)

After adjusting, the measuring span specified on the rating plate may no longer match the new span.

A turn-down up to a maximum 1:100 (span ratio = r, turn-down) can be reached depending on the series and the measuring range.

The relationship between the measured pressure and the generated output current is linear, except for the square root characteristic in differential pressure transmitters.

Example:

1. Given: a transmitter with a measuring span of 0 to 232 psi. Adjust it to a measuring span of 29 to 203 psi without applying a reference pressure. (The assumed pressure will be zero psi or the lower sensor limit whichever is greater.)
2. Press the M pushbutton to select mode 5.
3. Adjust zero to 29 psi by pressing the \uparrow or \downarrow pushbutton.
4. Press the M pushbutton to save the value and select mode 6.
5. Adjust full scale to 203 psi by pressing the \uparrow or \downarrow pushbutton.
6. Press the M pushbutton to save the value.

6.2.4.2 Practical Applications

Set zero and full scale (blind):

1. Select the pressure input engineering unit.
2. Press the M pushbutton to select mode 5.
3. Press the \uparrow and \downarrow pushbuttons simultaneously and hold for 2 seconds. Zero is set to lower sensor limit.
4. Press the M pushbutton to save the value and select mode 6.
5. Press the \uparrow or \downarrow pushbuttons and hold for 2 seconds. Full scale is set to the upper sensor limit.
6. Press the M pushbutton to save the value.

Adjust zero and full scale (blind):

1. Select the pressure input engineering unit.
2. Press the M pushbutton to select mode 5.
3. Adjust zero by pressing the \uparrow or \downarrow pushbutton. This value will produce 4 mA.
4. Press the M pushbutton to save the input pressure value and select mode 6.
5. Adjust full scale by pressing the \uparrow or \downarrow pushbutton. This value will produce 20 mA.
6. Press the M pushbutton to save the input pressure value.

6.2.5 Zero Adjustment (Position Correction)

The zero error resulting from a non-vertical installation position can be easily corrected. This procedure can be performed locally using the magnetic pushbuttons or remotely using the HART Communicator. Section 7 Calibration and Maintenance discusses the cause of this zero error.

Important

To zero an absolute pressure transmitter, a vacuum must be applied! The zero adjustment of a ventilated absolute pressure transmitter will cause an erroneous zero set.

1. Ventilate or evacuate the transmitter.
 - Ventilate for pressure, differential pressure, flow, and flanged level transmitters.
 - Evacuate for absolute transmitters to <0.1% of the measuring span.
2. Select mode 7 by pressing the mode pushbutton.
3. Set zero by simultaneously pressing the \uparrow and \downarrow pushbuttons for 2 seconds; 0.000 will appear in the display.
4. Press the M pushbutton until no mode number is shown. An output current of 4 mA is generated.

6.2.5.1 Zero-Point Alignment at Absolute Pressure

Performing a position correction to an absolute pressure transmitters may not properly calibrate zero if a vacuum is not available as the reference pressure. In this case, the three options below are available.

- Perform a lower sensor alignment using the Communicator.

Carry out a lower sensor alignment at an applied, known and sufficiently stable reference pressure.¹

With this type of alignment, the digital displayed measured value is adjusted. The output current is relative to this displayed value.

- Set the current in mode 2 of local operation.

Use the formula below to calculate the current to be set for a known, sufficiently stable reference pressure. (See the footnote below.)

$$I = \frac{(p_{ref} - p_{sept})}{(p_{fso} - p_{zo})} * 16 mA + 4 mA$$

In model 2, enter this current with the \uparrow and \downarrow pushbuttons and save the value by pressing the M pushbutton.

With this setting, the digital displayed value is not changed.

- Change the value of the start of measurement in mode 5 of local operation:

¹ If the applied process pressure is known and sufficiently stable, it can be used instead of the reference pressure. Enter mode 4, when necessary, and enter an appropriate damping value.

Change the display, when necessary, by use of mode 13, so that the physical unit selected in mode 14 is in display mode.

Calculate the difference between the measured pressure and the known and sufficiently stable reference pressure. (See the footnote on the previous page.)

Change to mode 5. Add the calculated difference with the correct sign to the displayed measured start position. Enter this calculated value using the \uparrow and \downarrow pushbuttons and save the value by pressing the M pushbutton.

6.2.6 Fixed Current Output

The transmitter can be switched to a fixed current output mode for loop troubleshooting. Here, the analog output current will not vary with process pressure or level variations.

The fixed current output can be set locally or remotely to 3.6 mA, 4.0 mA, 12.0 mA, 20 mA, or 22.8 mA. Other values can be set using the HART Communicator.

1. Press the M pushbutton until mode 8 is shown on the transmitter display.
2. Set zero by simultaneously pressing the \uparrow and \downarrow pushbuttons for 2 seconds; the selected current will appear in the display.
3. Select the desired current by pressing the \uparrow or \downarrow pushbutton.
4. To cancel the fixed current mode, press the M pushbutton.

6.2.7 Failure Current

The failure current is the current that is to be output in the event of a fault or alarm. The default values are 3.6 mA and 22.8 mA. These values can be changed using the HART Communicator.

1. Press the M pushbutton to display mode 9.
2. Select the desired fault current by pressing the \uparrow or \downarrow pushbutton.
3. Press the M pushbutton to save the selection and exit mode 9.

6.2.8 Pushbutton and Function Disable

Mode 10 is used to disable some or all magnetic pushbutton functions. In addition, a write protect function can be activated to prevent changing of saved parameters. There are five options as shown in Table 6.3.

TABLE 6-3 Pushbutton and Function Disable Options

Symbol	Explanation
no symbol	No disable.
LA	Input pushbuttons disabled. Operation via HART is enabled.
LO	Zero can be set; all other functions are disabled. Operation via HART is enabled.
LS	Only zero and full scale can be set (see Section 6.3); all other functions are disabled. Operation via HART is enabled.
L	Write protect enabled. Operation by HART disabled.

LL is another pushbutton disable that is available in HART; see Section 6.4.9. The disable option symbol will appear in the lower left quadrant of the digital display. To cancel a disable option, see Section 6.2.1.

To select a pushbutton or function disable option:

1. If LO or LS is to be selected, first press the M pushbutton to go to mode 13. Select either Current in mA or Current in %. Otherwise, a change in the output variable will not be detected when an arrow pushbutton is pressed.
2. Press the M pushbutton to go the mode 10. Select a disable option by pressing either arrow pushbutton.
3. Press the M pushbutton to save the selection.

Note

When a transmitter is delivered without a display, disable option LS is active. If the transmitter is to be permanently operated without a display, be sure option LS remains active.

6.2.9 Flow Measurement (Differential Pressure only)

Select the characteristic of the output current as follows:

- Linear - proportional to the differential pressure
- Square Root - proportional to the flow

Below the square root function's switch point the output current can have a linear characteristic or be switched off. See Figure 6-2.

To select the characteristics:

1. Press the M pushbutton to enable mode 11.
2. Press either arrow pushbutton to select the desired characteristic.
3. Press the M pushbutton to save the selection.
4. Press the M pushbutton to enable mode 12.

5. Press either arrow pushbutton to select an switch point between 5 and 15%.
6. Save the selection by pressing the M pushbutton.

Note

If the input pressure is selected for display in mode 13 and the square root characteristic in mode 11, the differential pressure corresponding to the flow and the root sign are displayed.

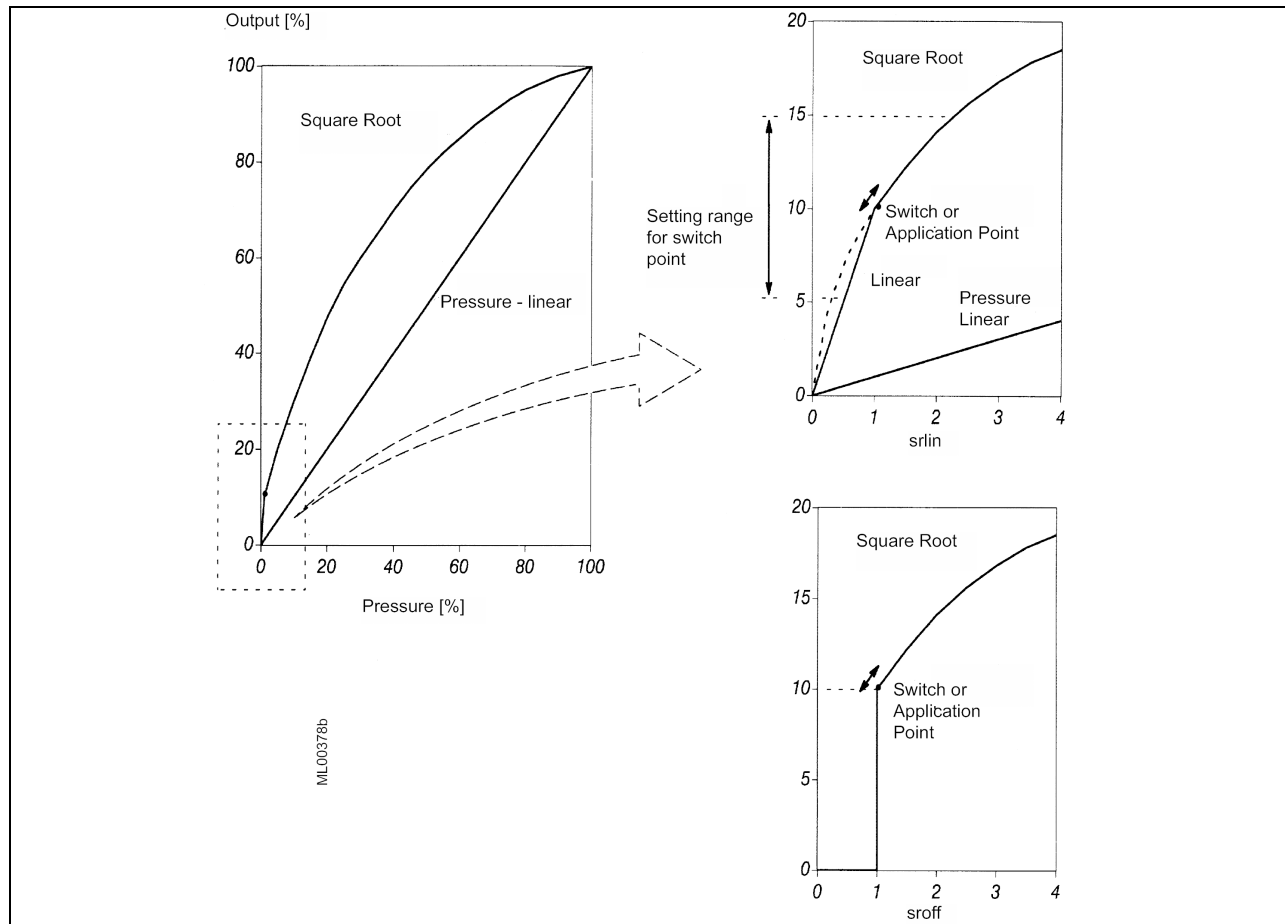

FIGURE 6-2 Switch Point of the Square Root Characteristic

6.2.10 Select Measured Value to be Displayed

Mode 13 has three options:

- Display output current in mA
- Display output current in % (of the set measured range)
- Display input pressure in engineering units selected in mode 14

To make a selection:

1. Press the M pushbutton to enable mode 13.
2. Press either arrow pushbutton to select the desired option.
3. Press the M pushbutton to save the selection.

6.2.11 Select the Displayed Input Pressure Engineering Unit

Mode 14 selects the engineering units that are to be assigned to the displayed input pressure (selected in mode 13). Available selections are shown in Figure 6-3. The engineering unit set using HART (Section 6.4.11) has no effect on this local setting.

1. To select the engineering unit:
2. Press the M pushbutton to enable mode 14.
3. Press either arrow pushbutton to step through the available engineering units list.
4. Press the M pushbutton to save the selection.

If the capacity of the digital display is exceeded, 9.9.9.9 will appear.

	bar
	mbar
	mm water column (20°C/68°F)
	Inch water column (20°C/68°F)
	Feet water column (20°C/68°F)
	mm mercury column
	Inch mercury column
	psi
	Pa
	KPa
	MPa
	g/cm ²
	kg/cm ²
	Torr
	ATM
	Inch water column (4°C/39°F)
	mm water column (4°C/39°F)

Calculated and displayed according to the dimension set with HART.

MG00361a

FIGURE 6-3 Displayable Engineering Units

6.3 LOCAL OPERATION WITHOUT A DISPLAY OR WITH ACTIVATED KEYLOCK

When a transmitter is ordered without a display, pushbutton disable mode LS is the default setting. Limited operation from the magnetic pushbuttons is available. This section describes local operation when the display is not present or when the magnetic pushbuttons or several modes have been disabled. Refer to Section 6.2.8 for the pushbutton and function disable options. To cancel magnetic pushbuttons disable, refer to Section 6.2.1. In most instances, it will be possible to set zero and full scale, as described in the section below.

6.3.1 Set Zero and Full Scale

The differences between set and adjust were discussed in Section 6.2.2.1. The same conditions and mathematical relationships apply whether operating with or without a display.

Use the following procedure to set the output current for zero to 4 mA and the full scale to 20 mA.

1. Apply a reference pressure corresponding to zero.
2. Press both arrow pushbuttons simultaneously so that the output is set to 4 mA.
3. Press the M pushbutton to save the setting.
4. Apply a reference pressure corresponding to full scale.
5. Press both arrow pushbuttons simultaneously so the output is set to 20 mA.
6. Press the M pushbutton to save the setting.

If the output current is not set but adjusted continuously, the currents will need to be calculated; refer to Section 6.2.2.1 as needed. It is possible to make an adjustment for zero, full scale, or for both values.

To set zero and full scale:

1. Clean the enclosure to prevent dirt from entering.
2. Unscrew the end cap covering the electrical terminals.



Explosion can cause death or serious injury.

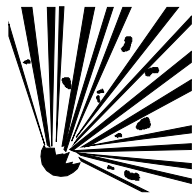

Only a certified ammeter may be used in intrinsically safe circuits.

In a Division 1 area, where an explosion-proof rating is required, remove power from the transmitter before removing either enclosure cap.

3. Connect a DC ammeter to the test terminals in the field terminal assembly.
4. Apply a reference pressure.
5. Set the zero output using the arrow pushbuttons. The set value is saved when the pushbutton is released.
6. Apply a reference pressure.
7. Press and hold the M pushbutton.
8. Set the output current by pressing either arrow pushbutton. The set value is saved when the pushbutton is released.

6.4 REMOTE CONFIGURATION AND OPERATION BY HART

This section describes operation of the transmitter using the Model 275 HART Communicator. Alternatively, PC software such as SIMATIC PDM can be used. Refer to the operating instructions or on-line help provided with the software. Refer to Section 2 for details concerning use of the Communicator.

Appendix A has the complete On-Line Configuration Map (an on-line Map for the Model 375 Field Communicator is at the back of this manual). Refer to the map as necessary to navigate the menus. The HART command set is constantly being enhanced and the specific commands available with the HART Communicator at hand may be different from those described here.

Most procedures in this section begin at the Online menu, which is shown here. The pulsing heart in the upper right corner of the display indicates that the HART Communicator and transmitter are communicating with each other.

In most of the procedures, text will appear above the function keys. These keys are immediately below the Communicator display. Refer to the table in Section 2 for function key (softkey) descriptions.

Write Protect

If an L is present in the lower left quadrant of the transmitter's display, write protect is enabled. Operating or configuring the transmitter from a remote HART device will not be possible.

To allow the HART device to operate or configure the transmitter:

1. Open the pushbutton access cover on the transmitter.
2. Press and hold the M pushbutton for at least 5 seconds. The letter L will extinguish and commands from the HART device will be accepted.

Write protect can be enabled either from the transmitter magnetic pushbuttons or from the HART Communicator. There are several levels of write protect. Refer to Section 6.2.8 or 6.4.9 for an explanation of write protect levels and methods of enabling.

6.4.1 Process Data

The Online menu displays pressure and transmitter type information. By pressing 3 on the HART Communicator keyboard, the Device Setup menu can be displayed and several other screens displaying process data can be accessed.

For example:

1. In the Online menu, press 3 Device Setup.
2. In the Device Setup menu, press 1 Process Variables.
3. The Process Variables display appears. It shows active data for pressure, % range, analog output, and sensor temperature.

Refer to the Online Configuration Map in Appendix A; the display of active data is indicated by a plus sign (+) following the menu text.

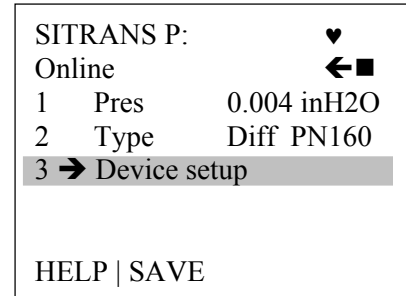

Note: If using a Model 375 Field Communicator, see the inside of the front cover of this manual.

6.4.2 Setting Zero and Full Scale

Zero and full scale can be set or adjusted from the HART Communicator. Following are the steps to set zero and full scale. To adjust zero and full scale locally, refer to Section 6.2.2.

Zero and full scale can also be set or adjusted in the Detailed Setup menu. See the Online Configuration Map in Appendix A for the path.

1. Apply a reference pressure that represents zero.
2. In the Online menu, press 3 Device Setup.
3. In the Device Setup menu, press 3 Basic Setup.
4. Press 4 in the Basic Setup menu and type a value for zero. Press the ENTER softkey to enter the zero value and return to the Basic Setup menu or press ESC to return to the Basic Setup menu without changing the zero value.
5. Apply a reference pressure representing full scale.
6. Press 5 in the Basic Setup menu and type a value for full scale. Press the ENTER softkey to enter the full scale value and return to the Basic Setup menu or press ESC to return to the Basic Setup menu without changing the zero value.

6.4.3 Blind Setting of Zero and Full Scale

Zero and full scale can be set without applying a reference pressure. Both values are freely selectable, within sensor limits, as described above. The maximum turn down is 100:1, depending upon the transmitter series and measuring range. Section 6.2.4 contains a discussion of the theoretical relationships and an example.

6.4.4 Zero Adjustment for Position Correction

The zero error resulting from a non-vertical installation position (electrical enclosure directly over the sensor) can be easily corrected. This procedure can be performed locally using the magnetic pushbuttons or remotely using the HART Communicator. This procedure should be performed after transmitter installation. If necessary, it can be performed on the test bench if the transmitter is exactly oriented as it will be when installed.

Important

To zero an absolute pressure transmitter, a vacuum must be applied! The zero adjustment of a ventilated absolute pressure transmitter will cause an erroneous zero to be set.

Note

The useful measuring range is reduced by the pre-pressure. For example, at a pre-pressure of 40 inH₂O (1.45 psi), the useful measuring range of a 14.5 psi transmitter is reduced to 0 to 13.05 psi.

1. Install and pipe the transmitter. Ventilate or evacuate the transmitter.
 - Ventilate for pressure, differential pressure, flow, and flanged level transmitters.
 - Evacuate for absolute transmitters to <0.1% of the measuring span.
2. In the Online menu, press 3 Device Setup on the HART Communicator.
3. Press 3 Basic Setup in the Device Setup menu.
4. In the Basic Setup menu, press 3 Position Correction. A warning will appear: “Loop should be removed from automatic control.” Press the ABORT or OK softkey as appropriate.
5. A second warning will appear: “This will affect sensor calibration.”
6. The message “Apply 0 input [atmospheric pressure] the sensor” will appear. Press ABORT or OK as appropriate.
7. A “correction successful” message will appear followed by a Loop may be returned to automatic control message.

6.4.5 Electric Damping

Electric damping can be adjusted within the range of 0 to 100 seconds.

1. Press 3 Device Setup in the Online menu.
2. Press 3 Basic Setup in the Device Setup menu.
3. Press 6 Damping in the Basic Setup menu or cursor down, using the down arrow, to 6 Damp. Type a new damping value and press ENTER. Press ESC to exit the display without making any changes.

6.4.6 Fast Measured Value Acquisition (fast response mode)

This mode is designed exclusively for special applications such as fast acquisition of pressure spikes, such as a compressor surge. Here, the internal measured value acquisition is accelerated at the cost of accuracy. There is an increase in low-frequency noise in the measured value. For best accuracy, configure the transmitter for use at its maximum measuring span.

1. Press 3 Device Setup in the Online menu.
2. Press 4 Detailed Setup in the Device Setup menu.
3. Press 2 Signal Condition in the Detailed Setup menu.
4. Press 6 Measuring Speed in the Signal Condition menu.
5. Use the arrow pushbuttons to select: Fast, Medium, or Slow.
6. Press the ENTER softkey to save the selection and return to the Signal Condition menu.

6.4.7 Fixed Current Output

To aid in loop troubleshooting, the transmitter can be placed in a constant current mode.

To enable fixed current operation:

1. Press 3 Device Setup in the Online menu.
2. In the Device Setup menu, press 2 Diagnostics/Service.
3. In the Diagnostics/Service menu, press 2 Simulation.
4. Press 1 Simulation in the Simulation Test menu.
5. Press 1 Loop Test in the Simulation menu. A Warning message will appear: "Loop should be removed from automatic control." Press OK or ABORT as appropriate.
6. In the Choose Analog Output Level display, select: 4 mA, 20 mA, other, or End by pressing the appropriate number key. A message will appear confirming that the output is fixed at the selected value and a "C" will appear at the lower left of the transmitter display. Press OK or ABORT as appropriate.

To discontinue fixed current operation:

1. Navigate to the Choose Analog Output Level display as described above
2. Select option 4 End. A message will appear stating that the loop can be returned to control and the transmitter display will no longer contain the "C."

6.4.8 Fault Current

The lower and upper fault currents can be set in this procedure. Both indicate a hardware or firmware failure, a sensor break, or reaching an alarm limit (diagnostic alarm). In the case of a diagnostic alarm, ERROR will appear in the transmitter display, as described in Section 6.1.4. (Refer to the HART Communicator manual or NE 43, Standardization of the Signal Level for Fault Information from Digital Transmitters with Analog Output Signals, dated 18.01.94 for a detailed error list.)

1. In the Online menu, press 3 Device Setup.
2. In the Device Setup menu, press 4 Detailed Setup.
3. In the Detailed Setup menu, press 3 Output Condition.
4. In the Output Condition menu, press 1 Analog Output.
5. In the Analog Output menu, press 3 Alarms.
6. In the Alarms menu, select: 1 AO alarm type, 2 Alarm LRV, or 3 Alarm URV.
7. Type the new value and press ENTER or press ESC to return to the previous menu without storing a changed value.

6.4.9 Disabling the Transmitter Magnetic Pushbuttons and Write Protection

The table below correlates a symbol that appears in the lower left quadrant of the transmitter display with the type of pushbutton disabling.

TABLE 6-4 Pushbutton and Function Disable Options

Symbol	Explanation
no symbol	No disable.
LA	Transmitter magnetic pushbuttons disabled; operation via HART is enabled. At the transmitter, press the M pushbutton for 5 or more seconds to release.
LO	Zero can be set; all other functions are disabled. At the transmitter, press the M pushbutton for 5 or more seconds to release.
LS	Only zero and full scale can be set (see Section 6.3); all other functions are disabled. At the transmitter, press the M pushbutton for 5 or more seconds to release.
L	Write protect enabled; operation by HART disabled. At the transmitter, press the M pushbutton for 5 or more seconds to release.
LL	Input pushbuttons fully disabled. The disable can be released only via HART.

Magnetic pushbuttons operation is as described in Section 6.3 when option LS or LO is active. LL is a pushbutton disable that is available in HART.

To select a disable option or to disable a previous selection:

1. In the Online menu, press 3 Device Setup.
2. In the Device Setup menu, press 2 Diag/Service.
3. In the Diag/Service menu, press 3 Control Modes.
4. In the Control Modes menu, press 1 Local Keys Control Mode. The following options appear:
 - Enabled (transmitter magnetic pushbuttons is fully enabled)
 - Disabled (local reset) LA
 - Zero only enabled LO
 - Zero and Span enabled LS
 - Disabled (HART) LL
5. Cursor to the desired selection; press ENTER to save the selection and return to the previous menu.
6. Press SEND to immediately send the selection to the transmitter. Confirm the selection by noting the 2-letter display in the lower left of the transmitter's display.

To select write protection:

1. In the Online menu, press 3 Device Setup.
2. In the Device Setup menu, press 2 Diag/Service.
3. In the Diag/Service menu, press 3 Control Modes.
4. In the Control Modes menu, press 3 Set Write Protect.
5. In the Protection menu, press either 1 No or 2 Yes. Press ENTER to save the selection and return to the previous menu. Press ABORT to return to the previous menu without saving any changes.

6.4.10 Measured Value Display

The transmitter display can show the output current in mA, the output current in 0-100%, or the input pressure in a selected engineering unit. To select the displayed parameter and, if input pressure is desired, the engineering unit:

1. In the Online menu, press 3 Device Setup.
2. In the Device Setup menu, press 4 Detailed Setup.
3. In the Detailed Setup menu, press 4 Device Information
4. In the Detailed Information menu, press 5 Local Meter.
5. In the Local Meter menu, press 3 Local Display Units.
6. Cursor to the desired display unit. The current selection is shown at the top of the list and slightly offset to the left.

6.4.11 Select Pressure Engineering Units

This selection is used to choose the engineering unit assigned to the input pressure.

1. In the Online menu, press 3 Device Setup.
2. In the Device Setup menu, press 3 Basic Setup.
3. In the Basic Setup menu, press 2 (Engineering) Unit.
4. The presently selected unit is shown at the top of the list and slightly offset to the left. Cursor to the desired engineering unit using the Communicator's Up and Down Arrow keys. Press ENTER to save the selection and return to the previous menu. Press ESC to return to the previous menu without saving a new selection.

6.4.12 Display/Bargraph

In the display mode, the selection made in Section 6.4.10 will appear in the lower right quadrant of the display. The factory setting of the bargraph function is "off."

1. In the Online menu, press 3 Device Setup.
2. In the Device Setup menu, press 4 Detailed Setup.
3. In the Detailed Setup menu, press 4 Device Information.
4. In the Detailed Information menu, press 5 Local Meter.
5. In the Local Meter menu, press 4 Bargraph.
6. The current status of the bargraph is shown at the top of the list and slightly offset to the left. Cursor to the desired status: Not Active or Active. Press ENTER to save the selection and return to the previous display. Press ESC to return to the previous menu without saving a new selection.

6.4.13 Sensor Trim

Using sensor trim it is possible to set the characteristic of the transmitter at two adjustment points. This has the effect of improving the measurement accuracy by setting the sensor's upper and lower values close to the range of process pressure values. The adjustment points are freely selectable within the sensor's nominal range.

Transmitters not turned down at the factory are adjusted at 0 psi and the nominal upper range limit. Those turned down at the factory are adjusted at the lower and upper limits of the set measuring range.

Application Examples:

- If the desired span is 725 psi for a transmitter with a maximum pressure of 925 psi, then to achieve the greatest possible accuracy for this value, make the upper sensor adjustment at 725 psi.
- A 925 psi transmitter is turned down to 58 to 101.5 psi. To achieve the greatest possible accuracy, make the lower sensor adjustment point at 58 psi and the upper adjustment point 101.5 psi.

Note

Pressure sources must be sufficiently accurate.

Either of the trimming procedures below can be cancelled without storing a new trim setting by pressing ABORT. The factory trims can be restored in the Diagnostics/Service menu. Refer to the Online Configuration Map in Appendix A.

6.4.13.1 Trimming the Lower Sensor Adjustment Point

In this procedure, the reference pressure representing the lower sensor adjustment point is applied and the transmitter is instructed to accept this pressure. This represents an offset shift of the characteristic, as shown in Figure 6-4.

1. Apply a reference pressure representing the lower sensor adjustment point.
2. In the Online menu, press 3 Device Setup.
3. In the Device Setup menu, press 2 Diagnostics/Service.
4. In the Diagnostics/Service menu, press 4 Trim.
5. In the Trim menu press, 2 Sensor Trim.
6. In the Sensor Trim menu, press 3 Lower Sensor Trim. A warning message will appear: "Loop should be removed from automatic control." Take the appropriate action and press OK to continue. A second warning will appear: "This will affect sensor calibration." Again, press OK to continue.
7. The "Apply low pressure" message will appear. Press OK to continue. A "Pressure OK when pressure is stable" message will appear. Press OK to continue.
8. The applied value is displayed next. The value can be changed from the Communicator's keyboard. Press ENTER to store the value or press ABORT to exit the procedure without storing a value.
9. Remove the reference pressure or go to the next section to set the upper sensor adjustment point.

6.4.13.2 Trimming the Upper Sensor Adjustment Point

A pressure representing the upper sensor pressure is applied and the transmitter is instructed to accept this press. This corrects the characteristic slope; see Figure 6-4. Adjusting the upper sensor adjusting point will not affect the lower sensor adjusting point. The upper point must be greater than the lower point.

1. Apply a reference pressure representing the lower sensor adjustment point.
2. In the Online menu, press 3 Device Setup.
3. In the Device Setup menu, press 2 Diagnostics/Service.
4. In the Diagnostics/Service menu, press 4 Trim.
5. In the Trim menu press, 2 Sensor Trim.
6. In the Sensor Trim menu, press 4 Upper Sensor Trim. A warning message will appear: "Loop should be removed from automatic control." Take the appropriate action and press OK to continue. A second warning will appear: "This will affect sensor calibration." Again, press OK to continue.
7. The "Apply hi pressure" message will appear. Press OK to continue. A "Pressure OK when pressure is stable" message will appear. Press OK to continue.
8. The applied value is displayed next. The value can be changed from the Communicator's keyboard. Press ENTER to store the value or press ABORT to exit the procedure without storing a value.
9. Remove the reference pressure.

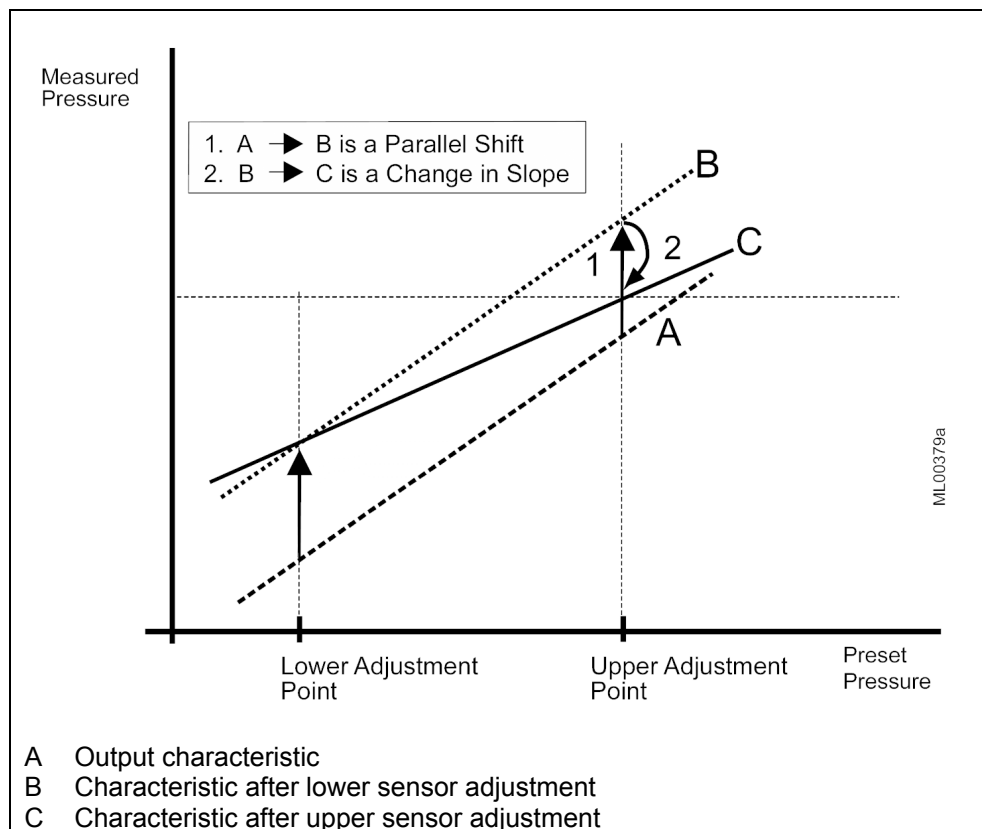

FIGURE 6-4 Sensor Trim

6.4.14 D/A Trim

There are two trim options: D/A trim and Scaled D/A trim. Since they operate similarly, only the D/A trim is described here.

Important

Trimming the D/A converter should not be necessary and should be performed only after all other options have been exhausted.

1. Remove the end cap from the enclosure terminal compartment. Connect a digital milliammeter to the provided terminals.



Explosion can cause death or serious injury.

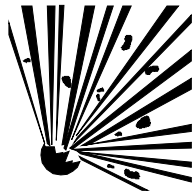

Only a certified ammeter may be used in intrinsically safe circuits.

In a Division 1 area, where an explosion-proof rating is required, remove power from the transmitter before removing either enclosure cap.

2. In the Online menu, press 3 Device Setup.
3. In the Device Setup menu, press 2 Diagnostics/Service.
4. In the Diagnostic/Service menu, press 4 Trim.
5. In the Trim menu, press 3 Trim Analog Output.
6. In the Trim Analog Output menu, press 1 D/A trim. A warning message will appear: "Loop should be removed from automatic control."
7. The message "Connect reference meter" will appear; see step 1. The message "Setting field device output to 4 mA" will appear. Press OK to continue. Type a new value and press ENTER. The message "Field device output 4.000 mA equal to reference meter?" will appear. Press 1 Yes or 2 No. If Yes is pressed, go to the next step. If No is pressed another opportunity to enter a new setting will be provided.
8. The message "Setting field device output to 20 mA" appears. Press OK to continue. Type a new value and press ENTER. Press 1 Yes or 2 No. Press OK to store the value and return to the previous menu.

6.4.15 Transmitter Current Adjustment

The current output by the transmitter can be adjusted independent of the input pressure signal and measuring circuit. This permits the output current to be adjusted to compensate for external inaccuracies, for example, the +/-0.5% tolerance of a current-to-voltage conversion resistor where 4 mA must yield exactly 1V and 20 mA must yield exactly 5V. These trims can be cancelled in the Diagnostics/Service menu and factory set trims again installed.

1. Determine the output currents required to compensate for the external inaccuracy.
2. Connect a reference milliammeter to the current terminals.



Explosion can cause death or serious injury.

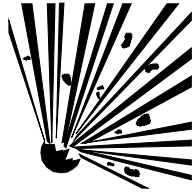

Only a certified ammeter may be used in intrinsically safe circuits.

In a Division 1 area, where an explosion-proof rating is required, remove power from the transmitter before removing either enclosure cap.

3. In the Online menu, press 3 Device Setup.
4. In the Device Setup menu, press 2 Diagnostics/Service.
5. In the Diagnostics/Service menu, press 4 Trim.
6. In the Trim menu, press 3 Trim Analog Output.
7. In the Trim Analog Output menu, press 1 D/A Trim. A warning will be displayed: Loop should be removed from automatic control. Press OK to continue.
8. Connect a reference digital milliammeter to the transmitter current terminals and press OK.
9. A “Setting field device output to 4 mA” message will appear. Press OK to continue.
10. Type a new current output value that corrects for the external inaccuracy (e.g. 4.001). Press ENTER to continue. A query “Field device output 4.001 mA equal to reference device?” Press 1 Yes or 2 No as appropriate.
11. A “Setting field device output to 20 mA” message is displayed. Press OK to continue.
12. Type a new current output value that corrects for the external inaccuracy. Press ENTER to continue.
13. A query “Field device output 20.000 mA equal to reference meter” appears? Press ENTER to continue. A confirming message displays followed by a “Loop may be returned to automatic control” message. Press OK to return to the Trim Analog Output menu.

6.4.16 Factory Calibration (Manufacturer Trims)

The factory calibration can be recalled (restored) in four steps.

- Restore the field current adjustment.
- Restore the field sensor zero adjustment (position correction)
- Restore the field pressure corrections (zero adjustment and sensor adjustment)
- Restore field selected parameters relevant to measured value processing, such as zero full scale, electric damping, display unit, current adjustment, zero adjustment (position correction, sensor adjustment, measuring speed, alarm current limits, alarm setting, and overflow current ranges.

To restore manufacturer trims:

1. In the Online menu, press 3 Device Setup.
2. In the Device Setup menu, press 2 Diagnostics/Service.
3. In the Diagnostic/Service menu, press 5 Restore Manufacturer Trims.
4. Select from the menu the desired trims to be restored and press ENTER.

6.4.17 Device Information

In the Device Information menu, the transmitter's physical configuration and materials and its software and hardware revision numbers can be recorded. Most of this information is included in the factory configuration; however, it can be edited as needed.

- Ranges and limits
- Common device information
- Sensor information such as flange type, O-ring material, fill fluid, and diaphragm material
- Remote seal specifics such as type and fill
- Local meter selections such as type and local display units
- Hardware and software revision numbers

Refer to the Online Configuration Map in Appendix A for details.

6.4.18 Flow Measurement (Differential Pressure)

The output current characteristic can be set to linear, proportional to differential pressure, or square root, proportional to flow. There are two square root settings that affect the current output characteristic from zero to the switch point (i.e. switch point). Figure 6-2 illustrates the three possible settings.

1. In the Online menu, press 3 Device Setup.
2. In the Device Setup menu, press 3 Basic Setup.
3. In the Basic Setup menu, press 7 Transfer Function.
4. In the Pressure Transfer Function menu, use an arrow key to cursor to the needed characteristic and press ENTER to save the selection and return to the previous menu.

6.4.19 Diagnostic Functions

Communication with the HART Communicator enables activation and evaluation of numerous diagnostic functions. The simulation of pressure and temperature measured values is possible, in addition to calibration and service timers, min/max pointers, and limit value monitoring components.

A diagnostic warning or alarm can be configured to monitor limit values (e.g. monitoring of current saturation).

Diagnostic Warning: The transmitter in which the diagnostic event has occurred notifies the HART Communicator of the warning. The moving text "Diagnostic Warning" scrolls across the transmitter display, alternating with the unit/bargraph display.

Diagnostic Alarm: The transmitter goes into a fault state. The message ERROR will appear and either “Diagnostic Warning” or “Diagnostic Alarm” will scroll across the transmitter display, alternating with the unit/bargraph display.

The default setting for all warnings and alarms is OFF. To set and enable:

1. In the Online menu, press 3 Device Setup.
2. In the Device Setup menu, press 2 Diagnostics/Service.
3. In the Diagnostics/Service menu, press 1 Diagnosis
4. In the Diagnosis menu, press 3 Warnings/Alarms. Refer to the Online Configuration Map in Appendix A and to the HART Communicator’s help screens.

6.4.19.1 Operating Hours Counter

Two operating hours counters with non-volatile memories are provided for the electronics and the sensor. These counters are not re-settable. If power is removed and later reapplied, the counters begin counting from the previous time. To read the operating hours counters:

1. In the Online menu, press 3 Device Setup
2. In the Device Setup menu, press 2 Diagnosis/Service
3. In the Diagnosis/Service menu, press 1 Diagnosis
4. In the Diagnosis menu, press 2 Operating Hours
5. In the Operating Hours menu, press 1 Operating Hours Electronics or 2 Operating Hours Sensor. The total operating hours will be displayed.

6.4.19.2 Calibration Timer and Service Timer

A two-stage time can be set to ensure regular calibration of the electronics and servicing of the transmitter. A calibration or service warning appears after the first time expires. On expiration of a second time, set as a time difference, a diagnostic alarm is signaled and a fault current is output.

A warning or alarm must be acknowledged before work can be performed on the transmitter. Timers can then be reset and switched off temporarily.

For operating/acknowledging warnings and alarms in the HART Communicator, the following applies:

As long as the warning/alarm limit has not been reached:

- “Reset” resets the timer and begins again with the counter at 0. Monitoring is still active.
- “Acknowledge” has no effect, the timer continues running and the monitoring is still active.
- “Reset and deactivate” stops the timer, resets it, and deactivates the monitoring.

When the warning/alarm limit has been reached:

- “Acknowledge” resets the warning/alarm message but the timer continues to run. In this state, no new alarm or warning is possible since the time limits will still have to be exceeded.
- “Reset” resets the warning/alarm message the timer. At the same time, the alarm or warning is acknowledged. The timer runs again immediately from zero and will respond again when the warning/alarm limit is exceeded. The next calibration interval is therefore immediately activated.
- “Reset and ActivateW/A” resets the arning/alarm message and resets and deactivated the timer.

6.4.19.3 Min/Max Pointer

The maximum positive and negative excursions of the input pressure, sensor temperature, and electronics temperature are stored in non-volatile memory for later recall. Min/Max pointers are updated during simulation. Stored values can be reset. Refer to the Online Configuration Map in Appendix for the path to the min/max pointer and to Figure 6-5 for an example.

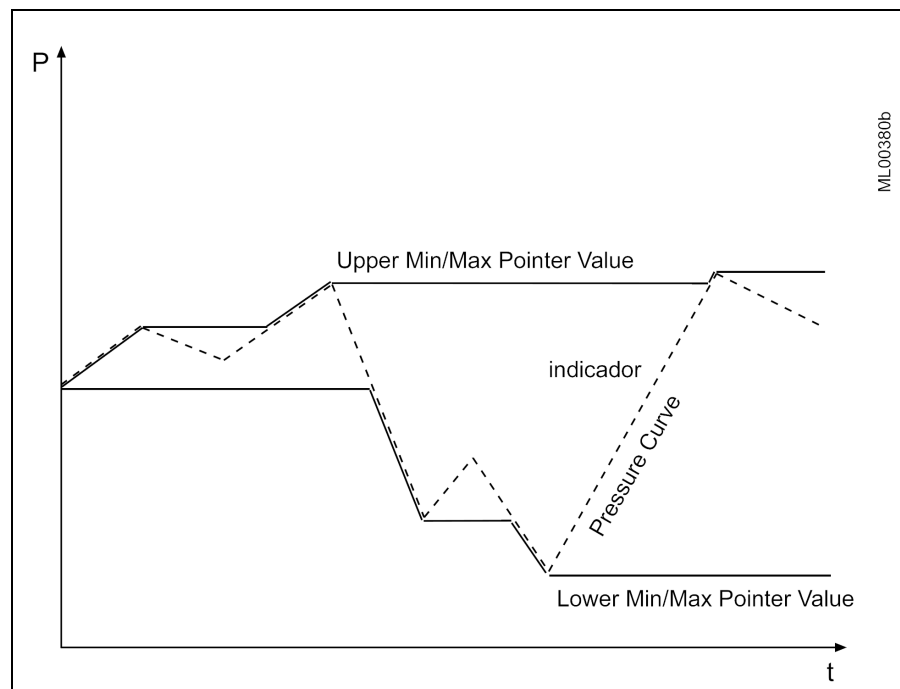

FIGURE 6-5 Pressure Min/Max Pointer Example

6.4.19.4 Monitoring the Saturation Current

Transmitter current output in the saturation range can be monitored with a simple limit value component. This component is configured and activated using the HART Communicator.

Two times need to be configured: response time and hold time. The response time represents the length of time the current output may remain saturated before an alarm is triggered and the transmitter outputs its set fault current. The hold time is the duration of the alarm.

In example 1 in Figure 6-6, the response time begins at t_1 when the output current, due to an increase in input pressure, reaches the configured saturation limit. At t_2 , the response time ends, the hold time begins, and the transmitter outputs the fault current. At t_3 , the hold time expires and the alarm is cancelled even

though the current has not dropped below the saturation limit. When the input pressure finally drops, the transmitter output current decreases from the fault current, through the saturation current and then begins to follow the input pressure.

In the second example, the duration of the input pressure spike that drives the current output to the saturation limit is shorter than the configured response time. Consequently, the transmitter will output the saturation current but not output a fault current.

In the third example, the input spikes below minimum pressure. At t_2 the response time expires and the hold time begins. The transmitter outputs the fault current at t_2 and holds that output until the hold time expires at t_3 .

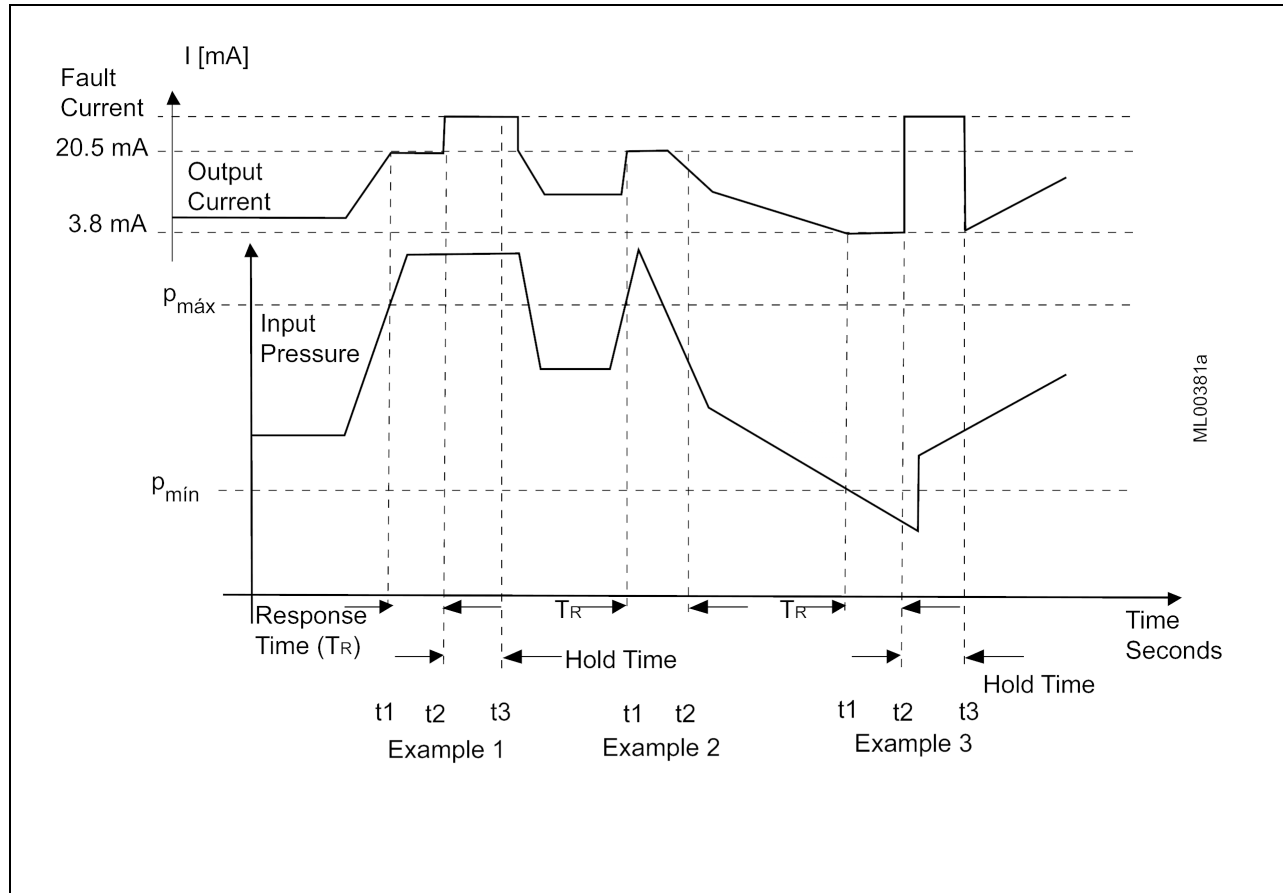

FIGURE 6-6 Saturation Monitoring Examples

6.4.20 Simulation

In the simulation mode, pressure and temperature values can be simulated within the transmitter without the need for an external input signal. Transmitter circuitry can be exercised and the resulting values output to an I/O module, controller, or other device to test the loop.

Simulation values are entered at the HART Communicator keyboard as described below. A pressure simulation can employ either a “fixed value” or a “fixed ramp,” with the number of steps configurable.

Simulation data is stored in RAM only. Consequently, when a simulation is ended, simulation values are deleted. Note that changing the temperatures by simulation has no effect on the measured pressure value. Also, as long as the simulation is active, the transmitter will not react to changes in process pressure.

Figure 6-7 is a block diagram of a transmitter showing the measuring and simulation blocks.

Simulation (Pressure and Temperature)

1. In the Online menu, press 3 Device Setup.
2. In the Device Setup menu, press 2 Diagnostics/Service.
3. In the Diagnostics/Service menu, press 2 Simulation Test.
4. In the Simulation Test menu, press 1 Simulation to display the Select menu. Choose one of the following.
 - 1 Loop Test: To test the loop, press 1. A warning message will appear: "Loop should be removed from automatic control." Press OK to continue. Then select either 4 ma, 20 mA, or a user-entered value and press ENTER. Select End or ABORT to exit and return to the previous menu. Press OK to return to the previous menu with the selected current sustained. To end the simulation, press either 4 End or ABORT and return to the previous menu.
 - 2 Inputs: From the menu that appears, select the pressure and/or temperature to be simulated. Pressure simulation can employ either a fixed value or ramped values (specify starting value, end value, step duration, and number of steps). Follow the on-screen prompts. End the simulation and return to the previous menu by pressing ABORT.

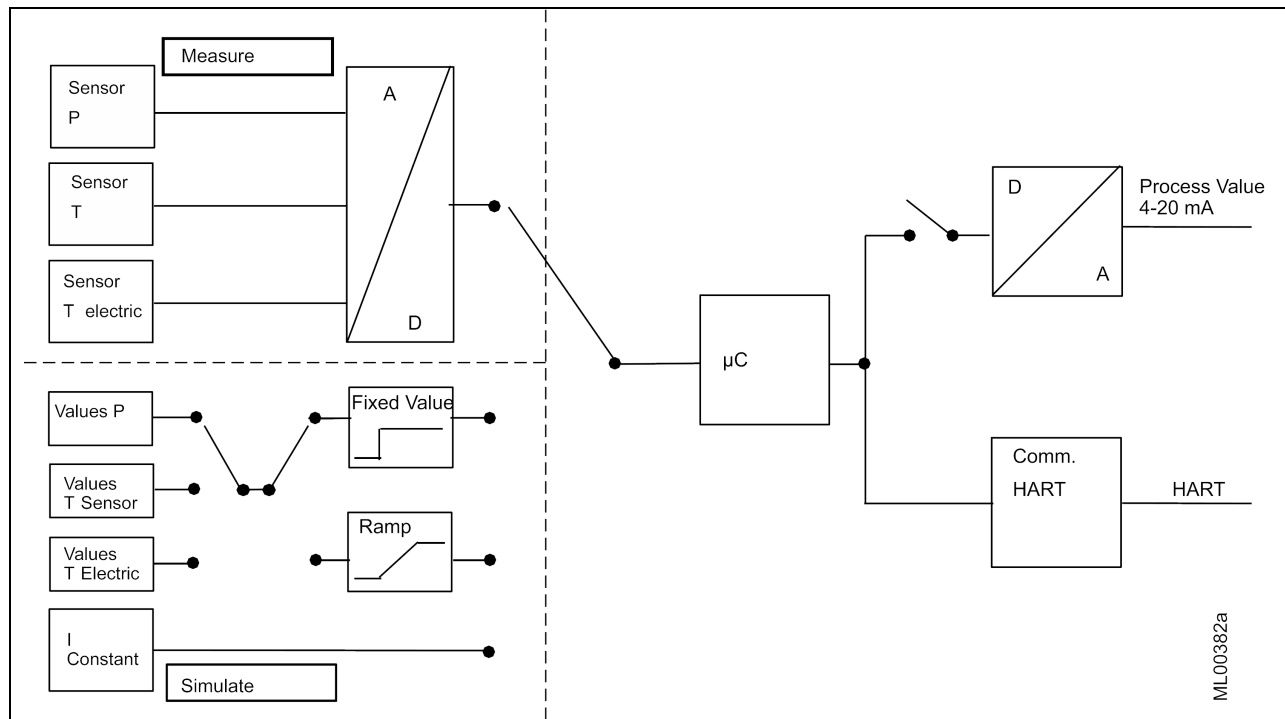

FIGURE 6-7 Simulation Circuit Diagram

6.4.21 Self Test and Master Reset

A transmitter self test or master reset can be initiated from the HART Communicator.

1. In the Online menu, press 3 Device Setup.
2. In the Device Setup menu, press 2 Diagnostics/Service.
3. In the Diagnostics/Service menu, press 2 Simulation Test.
4. In the Simulation/Test menu, press 2 Test
5. In the Test menu, press 1 Self Test to direct the transmitter to perform a self test of its internal circuitry or press 2 Master Reset to direct the transmitter to reset its internal circuitry. Follow the on-screen prompts. "Init" will momentarily flash in the display.



7.0 CALIBRATION AND MAINTENANCE

This section discusses calibration, preventive maintenance, troubleshooting, assembly replacement, software compatibility, and return shipments.

The Calibration section contains a brief discussion of the cause of position induced zero shift and it provides references to needed calibration procedures. The Preventive Maintenance portion has procedures that are employed to protect the reliability of the transmitter. Should a malfunction occur, procedures in the Troubleshooting section can help minimize downtime. The Assembly Removal and Replacement section provides step-by-step assembly replacement procedures. Later sections discuss recommended spare and replacement parts, software compatibility, and return shipments.

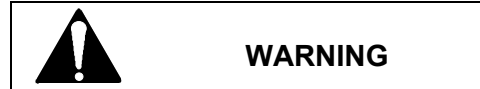
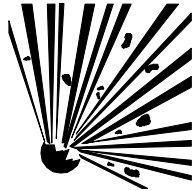

WARNING

Explosion can cause death or serious injury.

In a Division 1 area, where an explosion-proof rating is required, remove power from the transmitter before removing either enclosure cap.

Tools and Equipment Required

The procedures in this section can require the following equipment. See the Note below.

- Model 275 HART Communicator or Model 375 Field Communicator

Note: If using a Model 375 Field Communicator, see the inside of the front cover of this manual.

- Laboratory grade digital multimeter (DMM) for troubleshooting and calibrating the 4 to 20 mA output signal; a meter certified for use in intrinsically safe circuits must be used in an intrinsically safe installation

Voltmeter Section Accuracy $\pm 0.01\%$ of reading

Resolution 1.0 mV

Input impedance 10 M Ω

Ammeter Section Accuracy $\pm 0.1\%$ of reading

Resolution $\pm 1 \mu\text{A}$

Shunt resistance 15 Ω or less

- 24 Vdc power supply; for bench setup
- Resistor 250 $\Omega \pm 1\%$, carbon, $\frac{1}{4}$ watt; for bench setup
- Set of Phillips and flat-blade screwdrivers
- Set of open-end or box-end wrenches
- Larger tweezers, 4" to 6"

7.1 CALIBRATION

Calibration can involve adjusting zero to eliminate any position-induced zero shift, setting zero on-line, and trimming the digital to analog converter. Transmitter calibration should be checked annually and a calibration performed only if the transmitter is found to be out of tolerance. Trimming the D/A converter should not be necessary and should be performed only after all other options have been exhausted.

Zero Shift Explanation

Zero shift can be predicted. Transmitters are calibrated at the factory in a vertical position (enclosure directly over sensor). If a transmitter is installed (or will be installed) in another orientation, it may need re-zeroing to eliminate position-induced zero shift, depending upon transmitter type and direction of rotation. Maximum zero shift is 1.2 inches H₂O (299 Pa).

- There is no zero shift with transmitter rotation as long as diaphragm orientation with respect to the earth does not change.

For example, in the drawings below, rotating the transmitter from the vertical (center drawing) either 90° clockwise (right drawing) or counterclockwise (left drawing) will not cause a zero shift because diaphragm orientation with respect to earth has not changed.

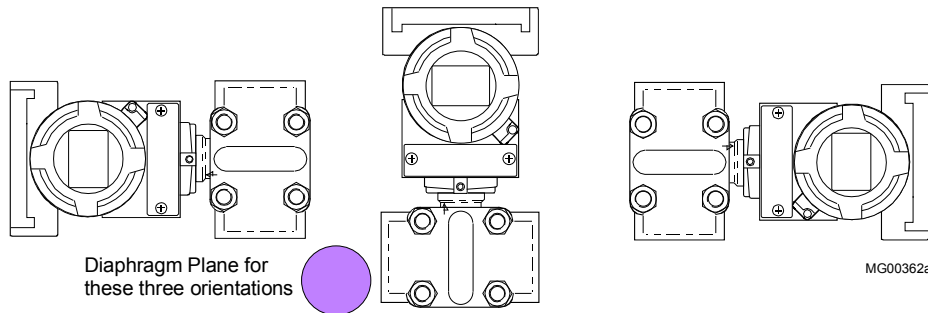

- Maximum zero shift occurs when rotating the transmitter causes diaphragm orientation with respect to the earth to be changed 90°.

For example, in the drawings below, rotating the transmitter from the vertical (center drawing) either 90° clockwise (right drawing) or counterclockwise (left drawing) will cause maximum zero shift because the diaphragm orientation changes from vertical to horizontal.

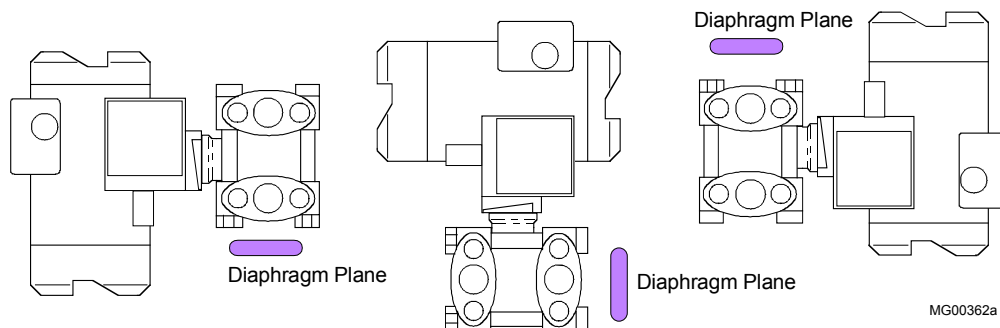

Calibration Procedure Section References

Calibration Needed	Local (Pushbutton)	HART Communicator
Position-induced zero	Section 6.2.5	Section 6.4.4
On-line zero	Section 6.2.2	Section 6.4.2
Calibrate DAC	---	Section 6.4.14

This completes calibration of the transmitter.

7.2 PREVENTIVE MAINTENANCE

Preventive maintenance consists of periodic inspection of the transmitter, cleaning the external surface of the transmitter enclosure, draining condensate from conduit, and blowing-down or purging impulse piping to keep them free of sediment. Perform preventive maintenance at regularly scheduled intervals.

7.2.1 Transmitter Exterior Inspection

The frequency of the inspection will depend on the severity of the transmitter's environment.

1. Inspect the exterior of the transmitter enclosure for accumulated oil, dust, dirt, and especially any corrosive process over-spray.
2. Check that both enclosure caps are fully threaded onto the enclosure, compressing the O-ring between the cap and the enclosure. The O-ring must not be cracked, broken, or otherwise damaged.
3. Inspect the display viewing glass for cleanliness and damage. Replace the enclosure cap assembly if the glass is damaged or missing.
4. Inspect both enclosure electrical conduit entrances for possible moisture leaks. An unused conduit entrance must be plugged and sealed. Inspect the cable clamps of all watertight cable conduits for loose clamps and deteriorated sealing material. Tighten clamps and reseal as necessary.
5. Inspect conduit drain seals for obstructions.
6. Inspect transmitter and mounting bracket hardware for tightness. Tighten loose hardware as necessary. Consider steps to reduce vibration.
7. Inspect process connection blocks for evidence of leakage at the impulse pipe connections and at the block interface to the transmitter end caps. As necessary, add sealant to pipe threads, tighten block bolts, and replace block Teflon® seals.

7.2.2 Transmitter Exterior Cleaning

After an exterior inspection of the transmitter, the enclosure can be cleaned with the transmitter operating.

1. Clean the enclosure (except enclosure cap glass) and process manifold with a mild, nonabrasive liquid detergent, and a soft bristle brush, sponge, or cloth. Rinse the weatherproof enclosure with a gentle spray of water.

Remove an excessive accumulation of process residue. Hot water or air may be used to flush away process residue if the temperature of the cleaning medium does not exceed the operating temperatures of the transmitter as listed in Section 9.3 Specifications.

2. Clean enclosure cap glass with a mild, nonabrasive liquid cleaner and a soft, lint-free cloth.

7.2.3 Transmitter Enclosure Interior Inspection

Remove the two enclosure caps periodically to inspect the interior of the transmitter enclosure.

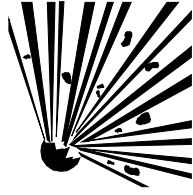

Explosion can cause death or serious injury.

In a Division 1 area, where an explosion-proof rating is required, remove power from the transmitter before removing either enclosure cap.

Important

Do not remove a transmitter enclosure cap in an area where the environmental substances can contaminate the transmitter interior.

- No accumulation of dust, dirt, or water (condensate) should be present inside the enclosure. If condensate is present, either install a conduit drain or repair the installed drain (see Figure 4-15).
- Check that all wire connections are tight.

7.2.4 Transmitter Calibration

An annual calibration check should be performed to ensure that the transmitter is within specifications. Refer to Section 7.1 for details.

7.2.5 Impulse Piping

To ensure accuracy and continued satisfactory performance, impulse piping must be kept clean and inspected for damage.

Sediment or other particles must not clog or collect in piping or the pressure chamber of the process manifold's process connection blocks. A build up of residue can cause faulty measurement.

1. Inspect impulse piping for loose, bent, or cracked piping. Replace damaged piping.
2. At regular intervals, blow down the piping without passing line fluids containing suspended solids through the process manifold's process connection blocks.

The time interval between blowdowns is determined by the user's previous experience with such systems or determined by evaluating system performance only after the transmitter has been in operation for a period.

7.3 TROUBLESHOOTING

This section provides guidance and procedures to assist in identifying and correcting a malfunctioning transmitter. Section 7.0 lists needed tools and equipment.

It is recommended that all documentation associated with the transmitter, including piping and loop wiring diagrams and configuration documentation, be obtained and made available to maintenance personnel to facilitate troubleshooting.

The most common symptom of a malfunctioning transmitter is incorrect, erratic, or no output. A malfunction can affect the transmitter's analog output (4-20 mA) or its digital (HART) output. Furthermore, a malfunction can be the result of external forces and not a transmitter fault at all. Section 7.3.1 discusses troubleshooting techniques for the analog output. Section 7.3.2 discusses troubleshooting techniques for the digital output.

General transmitter troubleshooting steps:

- Record all failure symptoms. Record the values and messages on the transmitter display. The display is discussed in Section 6 On-Line Calibration and Operation.
- Confirm the values and messages recorded above by connecting a HART Communicator (or DMM) and recording the values and messages shown by the Communicator. Navigate to those displays that show active data. Refer to Appendix A Online Configuration Maps to roam the Communicator's menus.
- Test the suspect unit by performing a transmitter self test or transmitter reset and again note the values and messages on the transmitter display and on the Communicator.
- Apply a known pressure (or level) and note all values and readings on the transmitter display and Communicator. See Section 5 Post Installation Tests for sample procedures.
- Check impulse piping, loop wiring, power supply, and related connections and equipment.
- Check the transmitter configuration.

7.3.1 Analog Output

An analog output problem can appear as one of the following:

- No output or very low output – There is no transmitter output or the output remains low despite changes in the process.
- High output – Transmitter output remains high despite changes in the process.
- Erratic output – Transmitter output varies when process does not.
- Sluggish response – Transmitter seems to respond to process changes very slowly.

Often an analog output problem is caused by incorrect transmitter configuration or by something external to the transmitter.

Transmitter Troubleshooting Steps

Several troubleshooting avenues are presented below. Select the appropriate path for the encountered symptoms.

- Record the readings in the numeric display, status arrows, and sign. Note the reading(s) in the unit/bargraph display, particularly any static or scrolling message. The display is discussed in Section 6 On-Line Calibration and Operation.
 - If the display is blank or partial characters appear, connect the HART Communicator in the loop. If the Communicator shows correct data, replace the display. If the problem remains, replace the electronics module. If the Communicator does not show correct data, use a voltmeter to confirm that power is applied to the transmitter. If power is applied, replace the electronics module.
 - ERROR appears on the display – There is a hardware or software malfunction. Replace the electronics module. If the problem remains, replace the measuring cell.
 - A static or scrolling message appears in the unit/bargraph display - This is a notice of a malfunction or a change in a status, warning, or alarm. Read the message and respond accordingly. Check the transmitter configuration and process conditions.
 - Warning/Alarm indication - Check the configuration of: Calibrate interval, Service interval, and AO saturation. The warning/alarm may be an indication that a configured time has elapsed or that the analog output has saturated. Check transmitter configuration and process conditions.
- Perform a transmitter self test or reset. Refer to Section 6.4.21 Self Test and Master Reset. Again check data and messages and repair as indicated.

Initially the numeric display will momentarily show “Init” and then display the current output (unless the display is set to read another parameter or ERROR appears). The unit/bargraph display will show the engineering unit (unless a fixed message or scrolling message appears or the unit/bargraph display is set to the bargraph mode). If a failed test message appears, repair as necessary.

- Check the pressure to current conversion. Connect a pressure source to the transmitter and connect the HART Communicator in the loop. Set the pressure source to produce a 4 mA transmitter output current. In the Online menu, press 3 Device Setup and then press 1 Process Variables to observe the active data. Refer to Appendix A Online Configuration Map as needed. Change the pressure to produce a 20 mA output current.

If a display is not installed, a milliammeter can be connected after removing the enclosure cap for access to the 4-20 mA test terminals.

- Place the transmitter in the simulation mode to apply a fixed or ramping current to the loop. Refer to Section 6.4.20 Simulation. Troubleshoot the controller or device receiving the transmitter output signal. Check the loop wiring at all loop-connected devices.

If selected loop currents are significantly out of tolerance, or loop current cannot be set, replace the electronics module (see Section 7.4). If the transmitter passes the fixed current (loop override) test, continue troubleshooting.

DSIII electronic modules are interchangeable. If troubleshooting points to a failed display or electronics module, substitute a known good assembly for another transmitter or from spare parts stock. See Section 7.4 for assembly replacement steps. Replacing the electronics module will necessitate reconfiguration of the transmitter since configuration data are stored in the module.

Check Impulse Piping

- Check that high and low pressure pipe connections are not reversed.
- Check for leaks or blockage.
- Check for entrapped gas in liquid lines or for liquid in dry lines.
- Check for sediment in transmitter's process connection blocks.
- Check that blocking valves are fully open and that bypass valves are tightly closed.
- Check that the density of the fluid in piping is unchanged.

Check Loop Power Supply/Wiring

- Check loop power supply for blown fuse or tripped circuit breaker.
- Check for 10.5 Vdc minimum across loop +/- terminals in transmitter terminal compartment.
- Check power supply output voltage: 15 Vdc minimum; 45 Vdc maximum (30 Vdc in an intrinsically safe circuit).
- Check polarity of loop wiring at both power supply and transmitter.
- Check for loose or broken loop wiring at power supply terminals, supply barriers (if used), junction boxes, and transmitter terminal compartment.
- Check for disconnected or broken current sense resistor.
- Check for short between shield and loop + wire.
- Check for accumulation of moisture in transmitter terminal compartment.
- Check loop cable for proper type and length.
- Check for electrical interference between the loop cable and any adjacent cables in a cable tray or conduit.

Check Transmitter Configuration

- Check for proper operating mode: analog, address 0; digital, address 1-15.
- Check for appropriate transfer function (linear or square root).
- Check the switch point if the square root output current characteristic (i.e. transfer function) is configured.

Check for a Transmitter Stuck in Fixed Current (Loop Override) Mode

- Re-enter Fixed Current mode from HART Communicator Online menu and properly exit the mode.

Check for Variable Process Fluid Flow

- Install mechanical dampers in process pressure piping.
- Select a higher damping value (software filter time constant).

Check Primary Element

- Check that primary element is correctly installed.
- Check element for damage and leaks.
- Note any changes in process fluid properties that can affect output.

7.3.2 Digital Output (Communication)

A malfunctioning digital output can indicate a defective communication circuit. More commonly, however, these problems are caused by an incorrect or poor installation. It is possible to install a transmitter such that the 4-20 mA signal is correct, yet the digital HART signal is not.

The most common symptom of a communication problem is the inability to locate a transmitter on the loop using a HART Master Device, such as the HART Communicator. Typical messages from the HART Communicator include: device disconnected, no device found, or communication error.

If communication problems occur, check the following. Refer to the specifications in Section 9 and to Section 4 Installation as necessary.

- Check that loop resistance is between 250 Ω and 1100 Ω .
- Check that electrical noise on the loop is not excessive: power supply ripple should not exceed 12 mVp-p.
- Check that there are no high inductance devices in the loop (I/P for example). Install a HART communication filter across such a device.
- Check that the power supply voltage is high enough for the installed total loop resistance. Refer to Section 4 Installation.
- Refer to Section 4 Installation and confirm that loop cable length is not excessive.
- Check that the HART Master is connected across a load.

7.4 ASSEMBLY REMOVAL AND REPLACEMENT

The display, electronics module, measuring cell, and terminal board assemblies are not user-serviceable; however, they may be replaced. This section describes removal and replacement of these assemblies. Refer to Section 7.0 for a list of tools. Figure 7-1 shows transmitter major assemblies.



Explosion can cause death or serious injury.

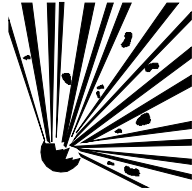

In a Division 1 area, where an explosion-proof rating is required, remove power from the transmitter before removing either enclosure cap.

This device has a modular structure. Use only Siemens authorized assemblies. When servicing, refer to the instructions enclosed with replacement parts.

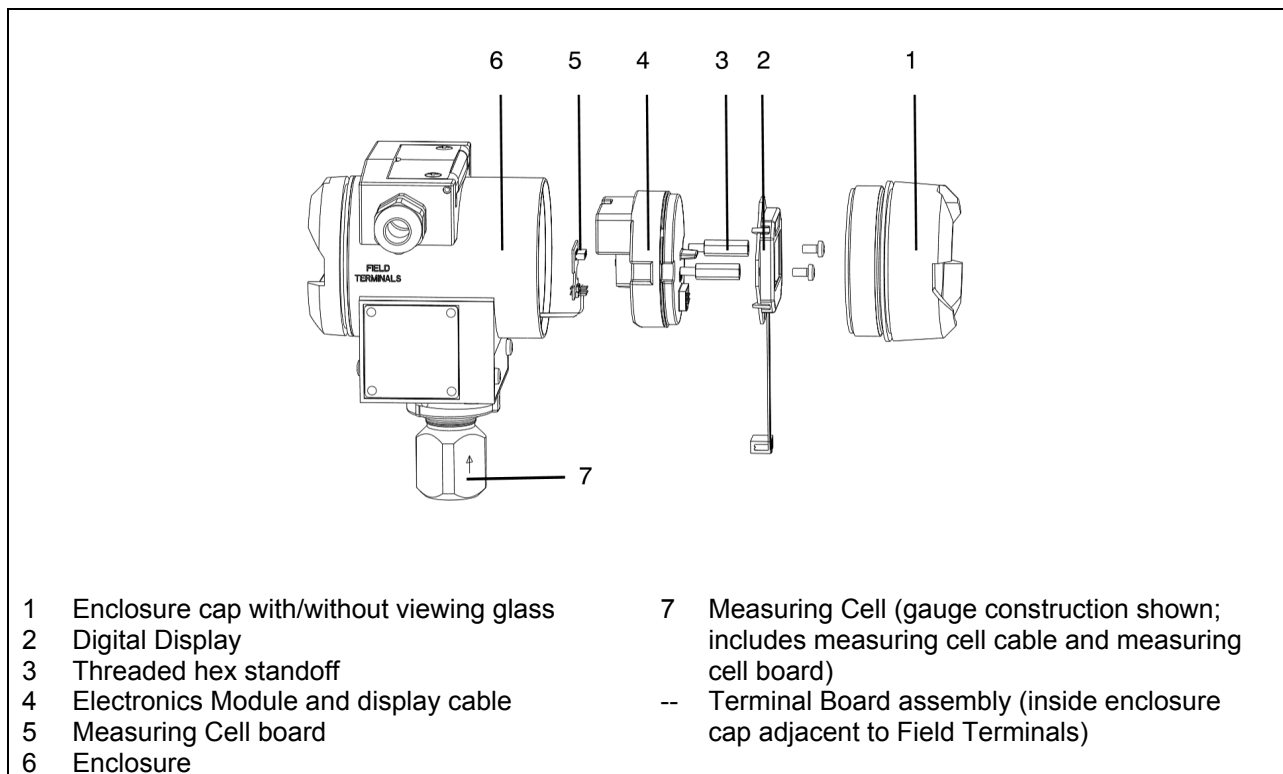

FIGURE 7-1 Transmitter Exploded View

The transmitter configuration must be reviewed after replacing either the electronics module (4) or the measuring cell (7). The following table identifies the parameters that are stored and those that will need to be entered.

Device Parameters After Replacing Electronics Module or Measuring Cell

Parameter Description	Stored	Not Stored (2)	Configuration Dependent (1)
Damping	x		
AO alarm type	x		
Alarm LRV/URV	x		
Saturation alarm activation	x		
Transmission functions	x		
Square root switch point	x		
Pressure units	x		
Polling address	x		
Tag	x		
Mechanical construction: electronics/sensor	x		
Min/max pointer	x		
Zero calibration	x		
Upper/lower sensor calibration points	x		
Service interval	x		
Minimum span	x		
Measurement limits			
Sensor limits			
Explosion protection	x		
Sensor serial number	x		
Working hour meter, sensor	x		
Working hour meter, electronics		x	
Firmware/Software revision			x
Min/max pointer, electronics		x	
Calibration interval, electronics		x	
Saturation alarm duration		x	
Local display unit			x
Current calibration			
Message		x	
Descriptor		x	
Date		x	
Final assembly number		x	
Bargraph activation			x
Write protection mode		x	
Hardware revision			x
Device revision			x
Unit tracking	x		

Notes:

(1) Column specifies sensor data that remains after changing electronics or sensor.

(2) Dependent on electronics module version. Check the parameters and configure as needed.

7.4.1 Display Assembly

Removal

1. Remove power from the transmitter.
2. Place an anti-static wrist strap on your wrist and connect its ground lead to the transmitter enclosure ground screw.
3. Unscrew the enclosure cap nearest the tag plate.
4. While holding the display assembly, loosen and remove the two Phillips-head screws securing the display circuit board to two hex stand-offs. See Figure 7.2.
5. Grasp the keyed display cable connector at the electronics module and disconnect it. Do not pull on the display cable. See the figure below.



Installation

1. Plug the keyed display cable into the connector in the electronics module.
2. Orient the display for best viewing (see Section 4.5 Installation as needed) and install the two Phillips-head screws. Tighten the screws to 5 in lbs (0.55 N-m).
3. Install the enclosure cap by turning it clockwise until the O-ring contacts the enclosure. Turn the cap one additional turn to compress the O-ring.
4. Remove the wrist strap.

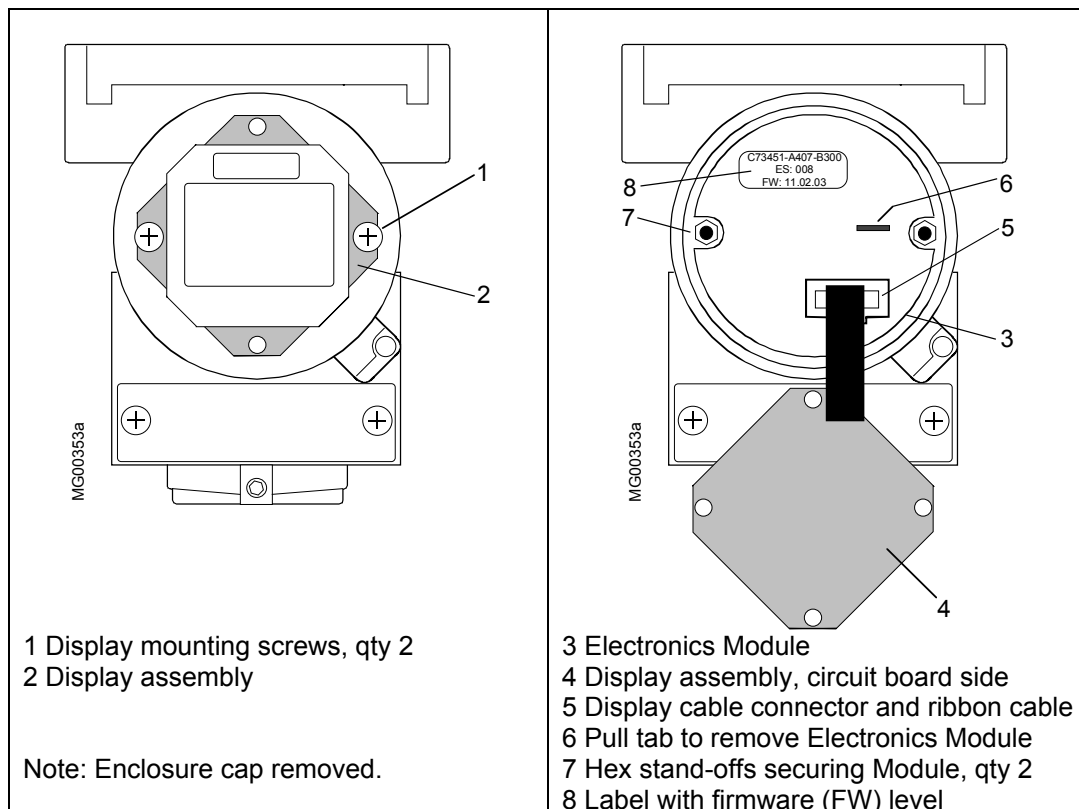

FIGURE 7-2 Display Assembly Installed and Partially Removed

7.4.2 Replacing the Electronics Module

A larger tweezers (4"-6") is very useful in the procedure below.

Removal

1. Fasten an anti-static wrist strap on your wrist and connect its ground lead to the transmitter enclosure ground screw.
2. If present, remove the display as described in the previous section.
3. Refer to Figure 7-2 and remove the two hex standoffs (7) using a 3/32" (7 mm) hex wrench. Grasp the pull tab (6) and withdraw the electronics module (3) from the enclosure. As shown in Figure 7-3, the measuring cell cable (4) is several inches long. Fold the module down so the back of the assembly is visible, as shown.



Important

Do not allow the electronics module to hang on the measuring cell cable. The measuring cell board and the cable are part of the measuring cell assembly. Damaging the board or cable will require replacement of the entire measuring cell.

4. On the back of the electronics module, locate the measuring cell board (2) and the measuring cell cable (4). The measuring cell board plugs into the electronics module and two flexible clips (3) secure the board. Grasp the board by inserting tweezers between the clips and the board. Slightly rock the board while applying outward pressure to ease the connectors apart.
5. Set the electronics module aside in an anti-static bag.

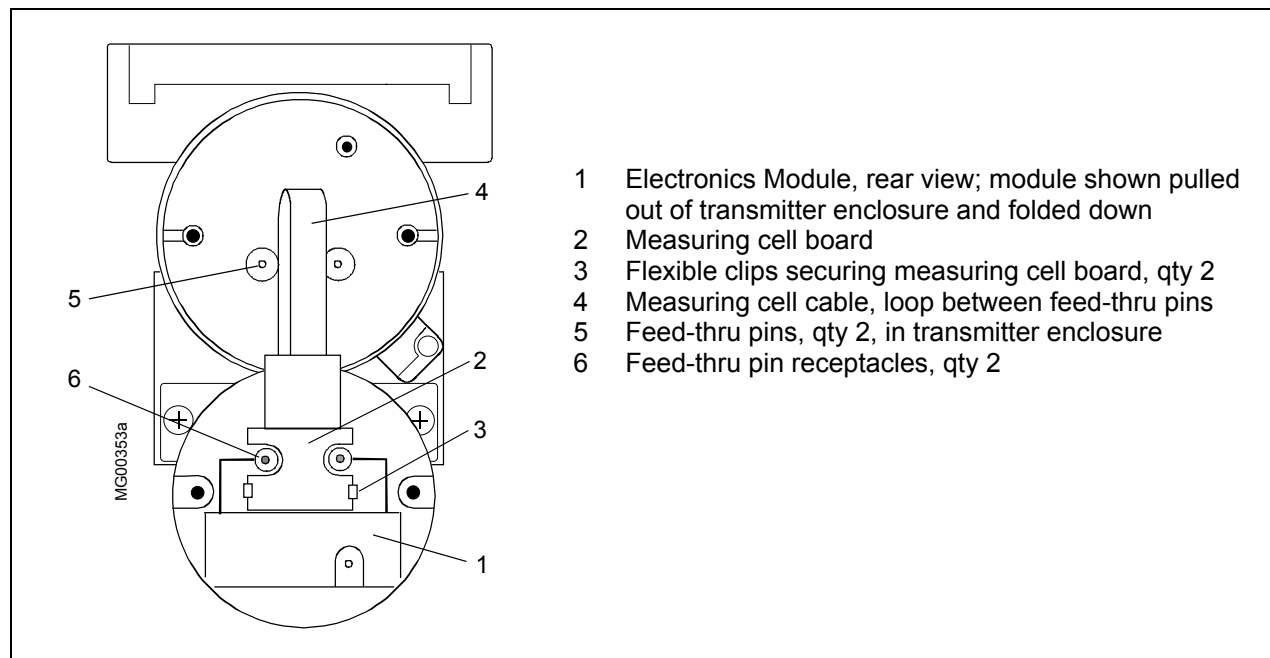

FIGURE 7-3 Electronics Module Removal and Installation

Installation

1. Remove the new electronics module from its anti-static bag.
2. Carefully align the connector on the measuring cell board with the connector on the back of the new electronics module. Press the board onto the electronics module until the board is seated fully and the flexible clips grip the board.
3. Move the electronics assembly close to the housing. Guide the measuring cell cable so that it folds between the two long feed-thru pins (5). Align the mounting holes in the electronics module with the holes in the casting. Press the electronics module into the enclosure. The two long pins must enter the two single pin receptacles (6) on the back of the module. Press the module in while gently rocking the module until it can be pressed in no farther.
4. Install the two hex standoffs. Tighten the standoffs securely but do not over tighten and damage the electronics module.
5. Install the display as described in the previous section.
6. Install the enclosure cap by turning it clockwise until the O-ring contacts the enclosure. Turn the cap one additional turn to compress the O-ring.
7. Apply power to the transmitter. Refer to the table in Section 7.4 and to Section 6 On-Line Configuration and Operation and configure the transmitter.

7.4.3 Measuring Cell Assembly Removal and Replacement

The measuring cell assembly is not field repairable. It must be replaced if defective. The transmitter must be removed to a workbench to accomplish removal and replacement.

A measuring cell assembly consists of the cell, process flanges (differential construction, as specified), measuring cell cable, measuring cell board and an O-ring.

Removal

1. Refer to Section 7.6 Transmitter Replacement and disconnect and remove the transmitter from service. Move transmitter to service shop.
2. Remove the enclosure cap for access to the display and electronics module.
3. If an optional display is installed, remove it as described in Section 7.4.1. Store the display in a static protective bag.
4. Remove the electronics module as described in Section 7.4.2.
5. Use a 3/32" (2.5mm) Allen wrench to loosen the enclosure rotation screw, located below the tag plate.

6. Separate the measuring cell from the enclosure.
 - Differential construction - Clamp the end cap portion of the measuring cell in a bench vise with the transmitter in an upright position. Use wood blocks to protect the end caps from damage by the vise. Rotate the enclosure clockwise while watching the measuring board and cable to be sure that they rotate freely.
 - Gauge construction - Use an open-end wrench to rotate the cell counterclockwise while watching the measuring board and cable to be sure that they rotate freely. Wrench size will depend upon the type of process connection.
7. As the measuring cell and enclosure separate, guide the measuring cell board through the neck of the enclosure and set the enclosure aside.
8. Clean all process material and other contamination from the entire assembly and pack the assembly for return or disposal. Include applicable MSDSs (Material Safety Data Sheets).

Installation

1. Unpack the replacement measuring cell.

If a greased O-ring is packed separately, go to step 2. If the O-ring is installed on the measuring cell tube, in a groove next to the threaded portion of the tube, go to step 3. Keep the greased O-ring clean and be careful not to wipe away the grease.

2. Pass the measuring cell board and measuring cell cable through the O-ring. Seat the O-ring in the groove in the measuring cell neck adjacent to the threaded portion of the neck. Keep the greased O-ring clean and be careful not to wipe away the grease.
3. Differential Construction only - Position the measuring cell in a bench vise with the measuring cell's tube pointing up. Use wood blocks to protect the end caps from damage.
4. Carefully pass the measuring cell board and cable through the enclosure neck and into the enclosure.
5. Screw the measuring cell into the enclosure. As the assembly is rotated, be certain that the measuring cell cable and board rotate freely.
 - Differential construction - Rotate the enclosure clockwise until the following conditions are met.
 - the enclosure setscrew should be in-line with the raised area in the center of the process flange; see Figure 7-4
 - the enclosure rotation arrow should be to the left of the enclosure setscrew
 - the neck dimension shown in Figure 7-4 is correct
 - Gauge construction - Using an open-end wrench, rotate the measuring cell until the following conditions are met.
 - the enclosure setscrew should be in-line with the enclosure rotation arrow
 - the neck dimension shown in Figure 7-4 is correct

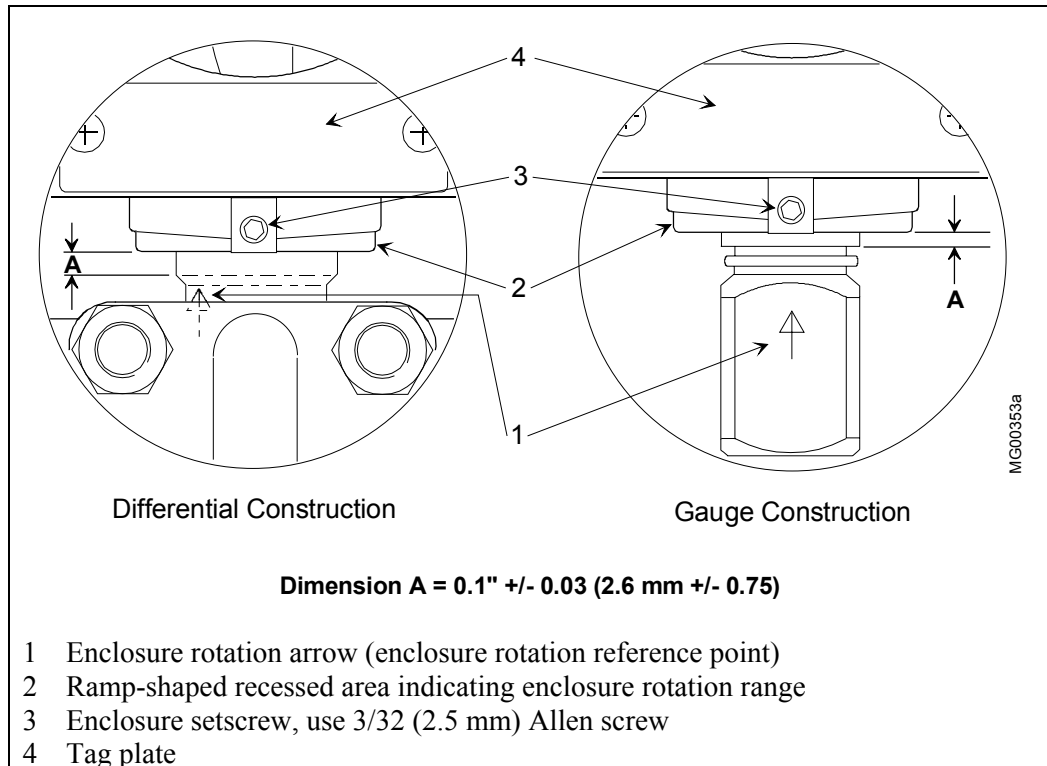

FIGURE 7-4 Measuring Cell Alignment and Insertion Depth

6. Tighten the enclosure setscrew to 30.1 to 30.9 in lbs (3.4 to 3.6 Nm).
7. Get the electronics module and connect the measuring cell board as described in Section 7.4.2.
8. Install the electronics module as described in Section 7.4.2.
9. Install the display as described in Section 7.4.1.
10. Install the end cap by turning it clockwise until the O-ring contacts the enclosure. Turn the cap one additional turn to compress the O-ring.
11. Apply power to the transmitter; see Section 3 for wiring diagrams. Refer to the table in Section 7.4 and to Section 6 On-Line Configuration and Operation and configure the transmitter.
12. Reinstall transmitter as described in Section 7.6 Transmitter Replacement.

7.4.4 Terminal Board Assembly Removal and Replacement

Perform this procedure to replace the terminal board assembly. The terminal board assembly usually can be replaced at the installation site; if not, remove the transmitter for bench servicing.

Removal

1. Use the proper procedures to shut down the process.
2. Remove power from the transmitter and remove the enclosure cap at the “Field Terminals” end of the enclosure to access the terminal board.
3. Retrieve the wrist strap from the maintenance kit and snap it on your wrist. Connect the ground clip to the transmitter ground screw.
4. Mark and then disconnect the loop wiring using a medium-size Phillips blade screwdriver, disconnect the wiring.
5. Remove two terminal board mounting screws and external tooth lockwashers.
6. Pull the terminal board straight out of the compartment.
7. Discard the defective board.

Installation

1. Retrieve the wrist strap from the maintenance kit and snap it on your wrist. Connect the ground clip to the transmitter ground screw.
2. Remove the replacement terminal board assembly from its packaging.
3. Note the two long feed-thru pins in the transmitter enclosure. These two pins must enter two receptacles on the circuit board side of the terminal board assembly. Carefully align the two mounting holes in the terminal board with the threaded holes in the enclosure casting and gently press the terminal board into place until it seats inside the enclosure. Do not use excessive force; do not bend the two long feed-thru pins!
4. Insert two terminal board mounting screws and lockwashers and tighten to 12 in-lbs (1.4 Nm).
5. Connect loop wiring.
6. Install the enclosure cap by turning it clockwise until the O-ring contacts the enclosure. Turn the cap one additional turn to compress the O-ring.
7. As necessary, reinstall the transmitter in the field.
8. Restore power to the transmitter. Calibration is not required.

7.5 NON-FIELD-REPLACEABLE ITEMS

Certain components are not replaceable except at the factory. These are:

- Enclosure cap display viewing glass: Agency regulations do not permit field replacement of a broken or damaged glass as this would invalidate the enclosure’s explosion proof rating. Replace the entire damaged enclosure cap assembly.
- RFI feed-thrus Potted

7.6 TRANSMITTER REPLACEMENT

To replace a transmitter, refer to the procedure below and one or more of the following Sections in the Installation section of this Manual:

- 4.4 Mechanical Installation
- 4.5 Mechanical Installation, All Models
- 4.6 Electrical Installation
- 4.7 Hazardous Area Installation



Disconnecting the transmitter from the loop must not release process material that is hazardous to people or can damage equipment. Depressurize the transmitter and drain process material as necessary.

Removal

1. Perform proper plant shut down procedures.
2. Remove power from transmitter. Open by-pass valves and close shut-off valves.
3. Remove the enclosure cap for access to the terminal board. Tag and disconnect loop wiring.
4. Disconnect the electrical conduit. Refer to Section 4.6 Electrical Installation. Replace the enclosure cap.
5. Disconnect the transmitter from the process. Depressurize and drain impulse piping. Refer to the Mechanical Installation section for the transmitter at hand; see above list.
 - Pressure or Flow Transmitter – Disconnect all process piping (e.g., impulse piping or 3-valve manifold). Then remove the transmitter from its mounting bracket.
 - Level Transmitter – Remove the transmitter from the mating flange.

Important

Before returning a transmitter, remove all process material. Material Safety Data Sheets for all hazardous process materials in contact with the transmitter and the potential consequences of exposure must be enclosed with the transmitter.

Installation

1. Fasten transmitter to mounting bracket. Refer to Mechanical Installation section for transmitter at hand.
2. Connect transmitter to process.
3. Connect conduit and loop wiring. Refer to Sections 4.5 Mechanical Installation, All Models and 4.6 Electrical Installation.
4. Orient display and enclosure for best viewing of the display. Refer to Section 4.5 Mechanical Installation, All Models.
5. Apply power to transmitter and configure. Refer to Section 6 Online Configuration and Operation.
6. Check all connections, then open shut-off valves and close by-pass valves. As needed, refer to Section 5 Post Installation Test.

Caution

Do not exceed the Maximum Overrange ratings when placing the transmitter into service. Properly operate all shut-off and equalizing valves. Ratings are listed on the rating plate and in Section 9 Model Designation and Specifications.

7. Check transmitter configuration as described in Section 3.4 Reviewing Configuration Data and Section 6 Online Configuration and Operation.
8. If needed, perform mounting induced zero shift calibration (see Section 7.1).

7.7 MAINTENANCE RECORDS

An accurate record keeping system for tracking maintenance operations should be established and kept up to date. Data extracted from the record may serve as a base for ordering maintenance supplies, including spare parts. The record may also be useful as a troubleshooting tool. In addition, maintenance records may be required to provide documentary information in association with a service contract. It is suggested that, as appropriate, the following information be recorded:

1. Date of service incident
2. Name or initials of service person
3. Brief description of incident symptoms and repairs performed
4. Replacement part or assembly number
5. Software compatibility code of original part
6. Software code of replacement part
7. Serial number of original part
8. Serial number of replacement part
9. Issue number of original circuit module
10. Issue number of replacement circuit module
11. Date of completion

7.8 RECOMMENDED SPARE AND REPLACEMENT PARTS

The quantity and variety of spare parts is determined by how much time a transmitter can be permitted to remain out of service or off line.

Replaceable parts are listed in Section 9 Model Designations and Specifications (Tables 9-7 to 9-13). Contact the factory if assistance is needed in determining quantity and selection of spare parts.

When ordering a part, provide the following information for the item, module or assembly to be replaced or spared. This information will help ensure that a repair addresses the observed problem, and that a compatible part is supplied.

1. Complete part number from Section 9 or from a label on the assembly
2. The single-digit software revision level
3. Model and serial number from the transmitter's nameplate
4. User purchase order number of original order, available from user records
5. New user purchase order number for the assembly to be replaced or spared
6. Reason for return for repair; include system failure symptoms, station failure symptoms, and error codes displayed.

Returns should be packaged in original shipping materials if possible. Otherwise, package item for safe shipment or contact factory for shipping recommendations. Refer to Section 1.4 Product Support to obtain a Return Material Authorization (RMA) number.

Important

The electronics module and display must be placed in static shielding bags to protect them from electrostatic discharge.

7.9 COMPATIBILITY, REVISION NUMBERS

From the HART Communicator, the transmitter can be asked to display four revision numbers.

- Universal Revision - This revision of the universal device description software enables communication between the transmitter and an external device, such as a HART Communicator.
- Field Device Revision - This Device Description is needed for detailed communication between the transmitter and other HART devices.
- Software (i.e. firmware) Revision - Since software controls the transmitter's operating routines and its HART communications with loop-connected stations and gateways. When requesting technical information or during troubleshooting, it often is necessary to know the transmitter's software revision level. A single digit identifies the transmitter software revision level.
- Hardware Revision - This is the revision number of the transmitter's hardware.

To view the revision numbers:

1. Establish communication with the transmitter (see Section 3.2).
2. In the Online menu, press 3 Device Setup.
3. In the Device Setup menu, press 4 Detailed Setup.
4. In the Detailed Setup menu, press 4 Device Information.
5. In the Device Information menu, press 6 Revision Numbers.
6. Read and note the revision number of interest.



8.0 CIRCUIT DESCRIPTION

This section provides a basic circuit description of the SITRANS P DSIII Pressure Transmitter. Figure 8-1 shows the functional block diagram. Basically the transmitter consists of two active components: a measuring cell and an electronics module. Input pressure is piped to the measuring cell (1) that includes diaphragms, fill fluid, and related components. The output signal from the measuring cell goes to the electronics module that consists of the microcontroller (4), A/D (3) and D/A (5) converters, HART modem (7), and related components. The magnetic pushbuttons (8) and display (9) connect to the electronics module.

The transmitter family consists of four model types: flow, differential pressure, absolute pressure, and flange-mounted liquid level. All models use the same interchangeable electronics module, display, enclosure, and magnetic pushbuttons. The major difference between models is the measuring cell.

The transmitters can communicate with a Model 275 HART Communicator, Model 375 Field Communicator, or a Primary Master controller using the HART protocol.

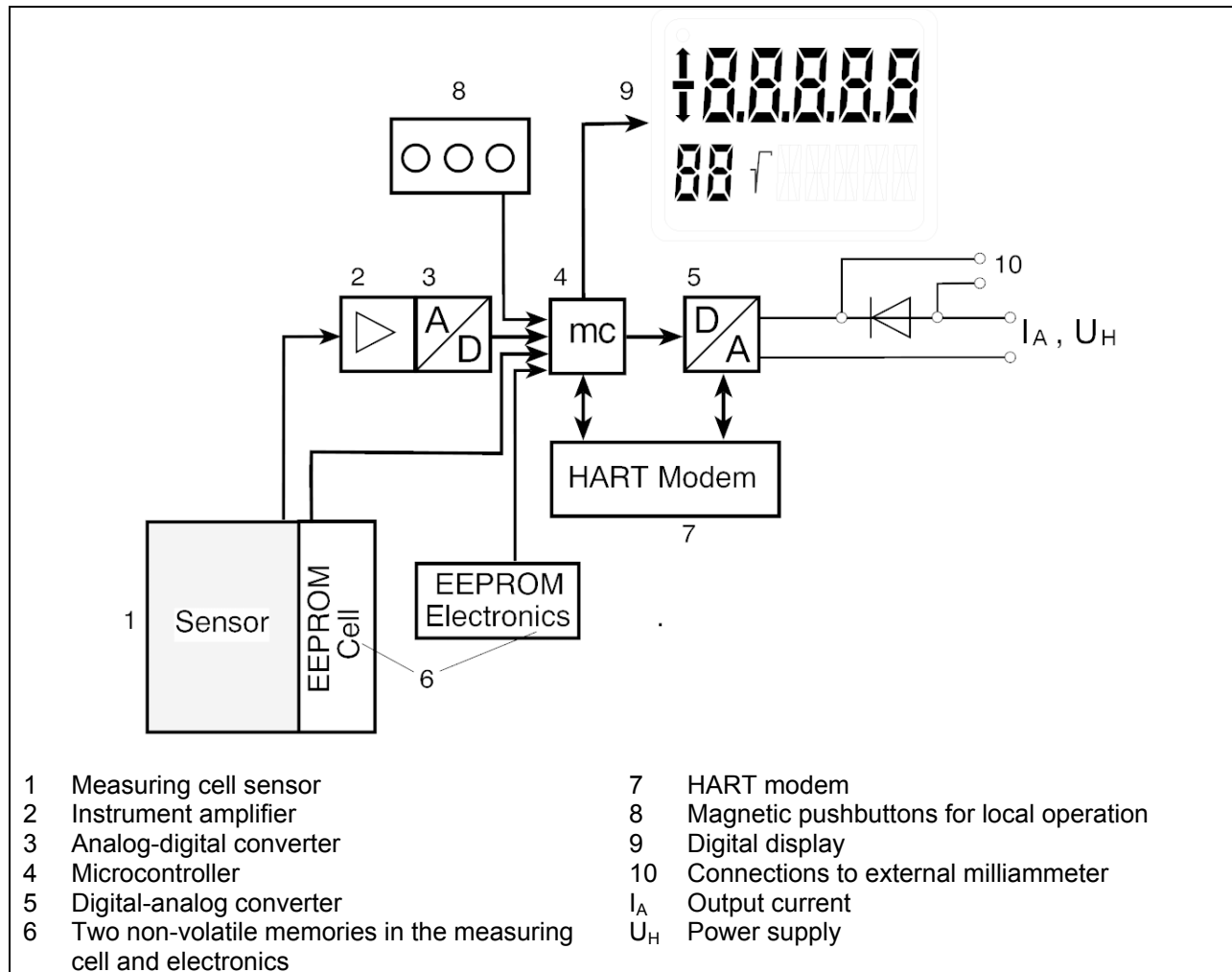

FIGURE 8-1 Transmitter Block Diagram

8.1 Overall Operation

The measuring cell sensor (1) detects the applied process pressure. The sensor's analog output signal is amplified by an instrument amplifier (2) and converted into a digital signal in an analog-digital converter (3). This data is evaluated by a microcontroller (4) that corrects the signal and temperature characteristics. Microcontroller output is converted to a 4-20 mA output current by the digital-analog converter (5).

A diode circuit (10) provides reverse polarity protection in the event of reversed loop connections. An external digital milliammeter can be connected across the diode. The diode and the electronics discussed in the previous paragraph are housed in an assembly named the electronics module.

Measuring cell-specific data (e.g. measuring range, measuring cell material, oil fill) are stored in a non-volatile memory (6) located in the measuring cell assembly. Transmitter configuration data (e.g. turn-down, electric damping) are stored in a second non-volatile memory (6) in the electronics module.

The transmitter can be configured locally using three built-in magnetic pushbuttons (8) or remotely, via the HART modem (7), using the HART Communicator. The digital display (9) shows input pressure, output current, error messages, modes of operation, or other data as determined by the configuration and by user commands via the magnetic pushbuttons or HART Communicator.

In the following sections, individual measuring cell types will be explained.

8.2 Pressure

As shown in Figure 8-2, process pressure p_e is applied to the measuring cell (2) through the process connection (3). This pressure is applied to the seal diaphragm which flexes to transfer the pressure to the fill fluid (5) which in turn transfers the pressure to the silicon pressure sensor (6).

The silicon pressure sensor consists of four piezo-resistors in a bridge circuit grown on the measuring diaphragm. The applied pressure causes a change in the bridge resistance that is proportion to the input pressure.

A transmitter with a measuring span of up to 925 psi will measure the input pressure compared to atmospheric pressure. A transmitter with a measuring span of 2320 psi compares input pressure to a vacuum.

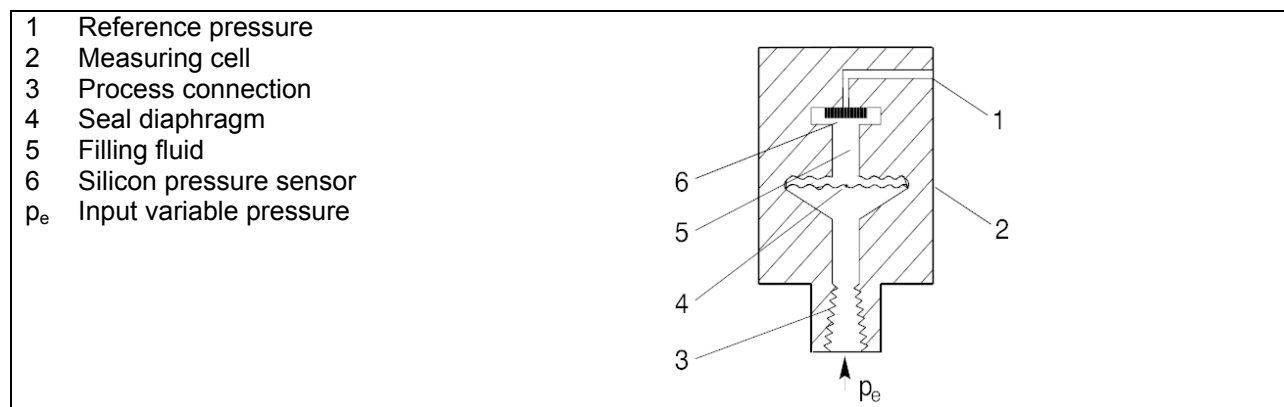

FIGURE 8-2 Pressure Measuring Cell

8.3 Differential Pressure and Flow

Differential pressure is applied to the silicon pressure sensor (4), a seal diaphragm (7) on either side of the measuring cell body, and the fill fluid (8). See Figure 8-3. When measuring limits are exceeded, the overload diaphragm (5) deflects until one of the seal diaphragms (7) comes into contact with the measuring cell body (4) to protect the silicon pressure sensor (3).

Four piezo-resistors in a bridge circuit are grown on the measuring cell diaphragm. The bridge change resistance in response to a change in input pressure. The change in resistance causes a bridge output voltage that is proportional to differential pressure.

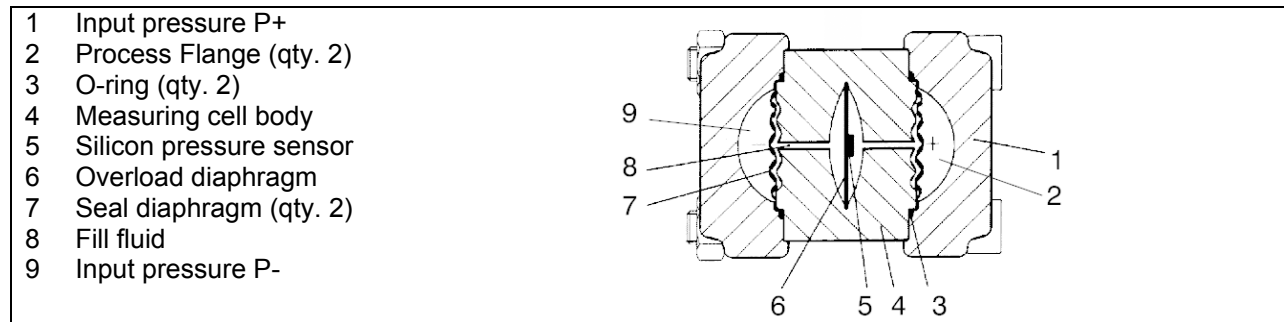

FIGURE 8-3 Differential Pressure and Flow Measuring Cell

8.4 Flanged Level

Input pressure (hydrostatic pressure) acts on the high pressure (+) side of the measuring cell through the seal diaphragm (10) at the mounting flange, the fluid filled capillary tube (8), the fluid filled cavity in the process flange, a seal diaphragm, and the fill fluid in the measuring cell body (4). See Figure 8-4. A differential pressure is applied to the low pressure (-) side of the measuring cell via the seal diaphragm (6) and fill fluid (7) to the silicon pressure sensor (3).

When measuring limits are exceeded, the overload diaphragm (5) deflects until one of the seal diaphragms (6) comes into contact with the body of the measuring cell (4) to protect the silicon pressure sensor (3).

The measuring diaphragm is flexed by the differential pressure. Four piezo-resistors in a bridge circuit are grown on the measuring diaphragm. Bridge resistance varies with pressure changes causing the bridge output voltage to vary in proportion to the change in applied differential pressure.

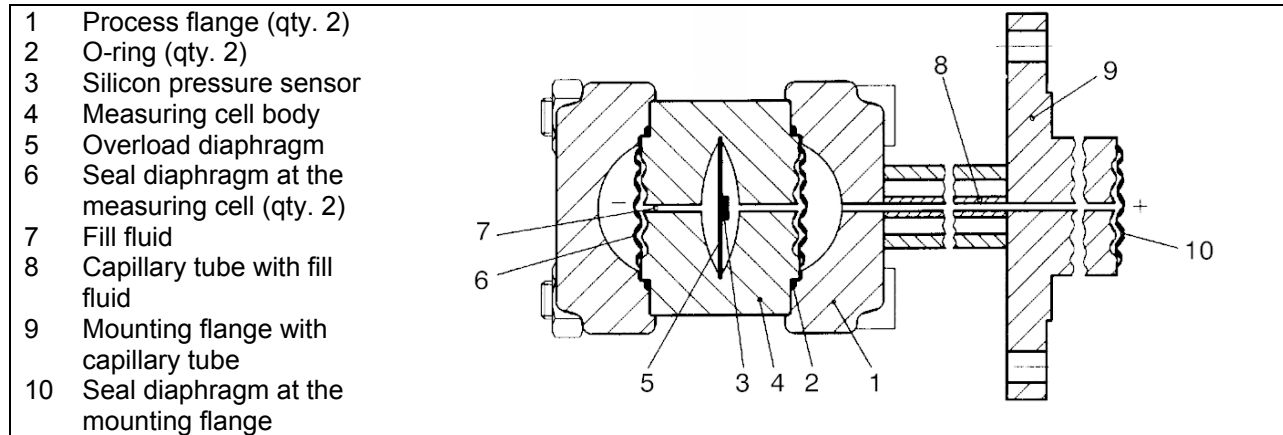

FIGURE 8-4 Flanged Level Measuring Cell

8.5 Absolute Pressure (Differential Construction)

Absolute pressure p_e is transferred via the seal diaphragm (2) and the fill fluid (7) to the silicon pressure sensor (5). The pressure difference between the input pressure (p_e) and the reference pressure (8) on the low pressure side of the measuring cell flexes the measuring diaphragm. Four piezo-resistors in a bridge circuit grown on the measuring diaphragm change their resistances in response to the change in applied pressure. The change in resistance causes a bridge output voltage change that is proportional to the absolute pressure.

If measuring limits are exceeded, the overload diaphragm (5) will deflect until the seal diaphragm comes into contact with the body of the measuring cell (4) protecting the silicon pressure sensor (5) against the overload.

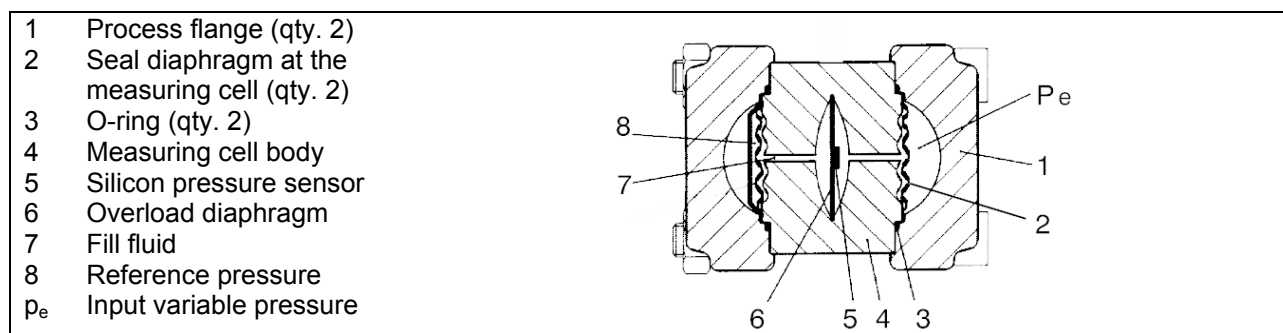

FIGURE 8-5 Absolute Pressure Measuring Cell, Differential Construction

8.6 Absolute Pressure (Gauge Construction)

Pressure p_e is applied via the seal diaphragm (3) and full fluid (4) to the absolute pressure sensor (5). See Figure 8-6. This flexes the measuring diaphragm on which four piezo-resistors in a bridge circuit have been grown. Bridge resistance will vary with the applied pressure to generate a bridge output voltage that is proportional to the input pressure.

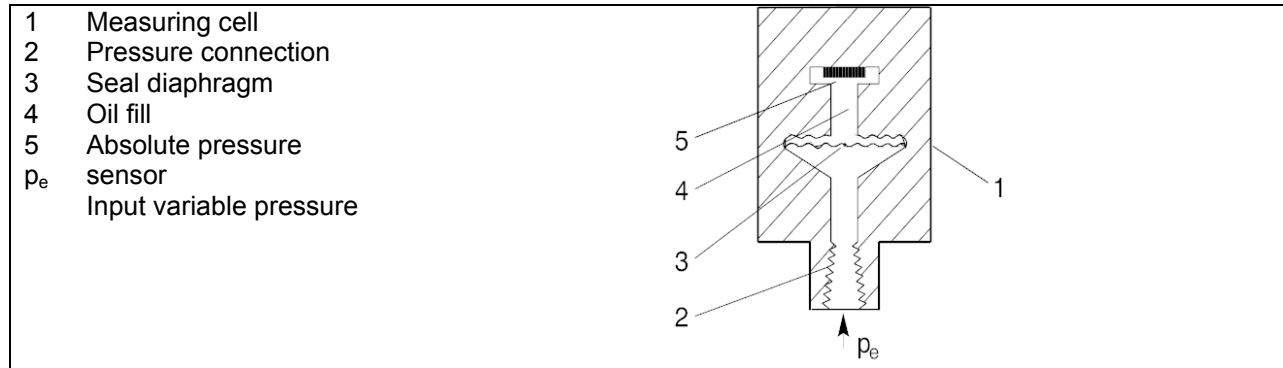

FIGURE 8-6 Absolute Pressure Measuring Cell, Gauge Construction

8.7 Communication Format

The transmitter communicates, via the HART protocol, with a HART Communicator and any HART capable Primary Master controller connected to the network.

HART communication uses phase-continuous frequency-shift-keying (FSK) at 1200 bits/sec and frequencies of 1200 Hz (logic 1) and 2200 Hz (logic 0). HART communication is superimposed (AC coupled) on the analog 4-20 mA signal. Because the digital signaling is high frequency AC, its DC average is zero and does not interfere with analog signaling.

An active filter connected to the loop input receives HART transmissions. The filter effectively rejects low frequency analog signaling and other out-of-band interference, preventing a compromise of the digital reception. The filtered signal is applied to a zero crossing detector, which converts the filtered information into clean pulses of uniform amplitude before introduction to the Bell 202 modem.

The modem receives and processes (e.g., demodulates) the serial FSK signal and outputs a signal to the microcontroller where serial to parallel conversion is performed.

In response to the received signal, the microcontroller outputs a signal to the modem where it is modulated and fed into the feedback circuit of a voltage-to-current converter for transmission over the loop.

■

9.0 MODEL DESIGNATIONS AND SPECIFICATIONS

This section contains the model designation tables, a comprehensive accessory list, functional and performance specifications, and hazardous area classifications for SITRANS P Series DSIII Pressure Transmitters.

Important

Before installing, calibrating, troubleshooting or servicing a transmitter, review this section carefully for applicable specifications and hazardous area classifications.

9.1 MODEL DESIGNATIONS

Tables 9-1 through 9-6 identify each entry on a transmitter's rating and approval plates. These plates carry important transmitter information:

- Model number and serial number (Rating Plate)
- Materials of construction (Rating Plate)
- Span and rated pressure (Rating Plate)
- Certifications (Approval Plate)
- User-supplied Tag (Tag Plate)

Service Parts

Tables 9-7 through 9-13 identify service parts.

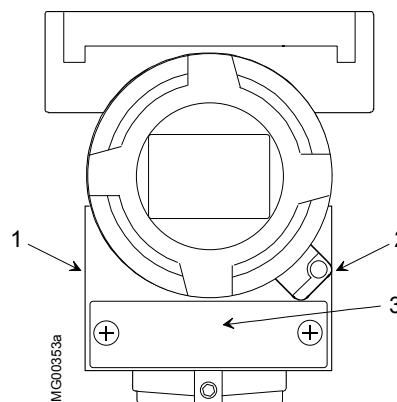

1. Rating Plate
2. Approval Plate
3. Tag Plate

Important

Before installing, applying or removing power, configuring, or servicing, confirm transmitter model by referring to the transmitter's model designation on its rating plate and in Tables 9-1 through 9-6.

The table below is an overview of measurement categories and available models. For details pertaining to a model, see its model designation table and its specification table later in this section.

Measurement	Models	Model Designation	Specifications	Dimensions
Absolute or Gauge Pressure	7MF4033	Table 9-1	Table 9-15	Figure 9-1
	7MF4233	Table 9-2	Table 9-16	Figure 9-1
	7MF4333	Table 9-3	Table 9-16	Figure 9-2
Differential Pressure	7MF4433	Table 9-4	Table 9-15	Figure 9-2 or 9-3
	7MF4533	Table 9-5	Table 9-15	Figure 9-2 or 9-3
Level (Flange)	7MF4633	Table 9-6	Table 9-16	Figure 9-4
	7MF4912	Table 9-6	Table 9-16	Figure 9-4

TABLE 9-1 Model 7MF4033, Model Designation

Pressure transmitter, two-wire, series DSIII, 7MF4033-													
<u>Measuring cell filling</u>		<u>Measuring cell cleaning</u>											
Silicone oil		Normal											
Inert		Grease-free			1								
					3								
<u>Span</u>		<u>PN</u>											
	0.15	To	15 psi	87 psi									
	0.60	To	60 psi	145 psi									
	2.3	To	230 psi	460 psi									
	9.25	To	925 psi	1450 psi									
	23	To	2320 psi	3625 psi									
	58	To	5800 psi	8700 psi									
<u>Material of wetted parts</u>													
<u>Process diaphragm</u>		<u>Connection shank</u>											
Stainless steel		Stainless steel											
Hastelloy		Stainless steel											
Hastelloy		Hastelloy											
Version for diaphragm remote process													
<u>Process connection</u>													
Connection shank G1/2 A													
Female thread 1/2-14 NPT													
Oval flange and connection shank, stainless steel, maximum span: 2320 psi:													
- Mounting thread 7/16-20 UNF													
- Mounting thread M10													
<u>Material of non-wetted parts</u>													
Housing diecast aluminum													
Housing stainless steel precision casting													
<u>Version</u>													
Standard version													
International version (in preparation)													
English plate description and documentation in 5 languages on CD													
<u>Explosion protection</u>													
without explosion protection													
with explosion protection (CENELEC):													
- Degree of protection "Intrinsic safety" (EEx ia) ³⁾													
- Degree of protection "Explosion proof" (EEx d) ¹⁾³⁾													
- Degree of protection "Intrinsic safety and explosion proof" (EEx ia + EEx d) ¹⁾³⁾													
Application in Zone 2 n (TÜV) ³⁾													
with explosion protection (FM intrinsic safety and explosion proof) ¹⁾													
with explosion protection (CSA intrinsic safety and explosion proof) ¹⁾													
with explosion protection (FM + CSA for IS + XP)													
<u>Electrical connection / cable inlet</u>													
Screwed gland PG 13.5 ²⁾³⁾		(Adapter)											
Female thread M 20 x 1.5													
Female thread 1/2-14 NPT													
Han 7D plug ²⁾³⁾													
<u>Housing cover / display</u>													
without window (digital display covered, setting: mA)													
with window (digital display, visible, setting: mA)													
with window (digital display visible, setting: as specified in Y20)													

Notes and "Other versions" on next page.

Other versions

Add "-Z" to order number and add short spec...	7MF4033 - - Z
Transmitter with mounting bracket of:	
- steel	A01
- stainless steel	A02
Han 7D plug (metal, gray) ³⁾	A30
Han 8U plug (instead of Han 7D) ³⁾	A31
Labeling of rating plate (instead of German):	
- English	B11
- French	B12
- Spanish	B13
- Italian	B14
Manufacturer test certificate M acc. to DIN 55 350, part 18, and according to ISO 8402	C11
Acceptance test certificate B acc. to DIN 50 049 / EN 10 204-3.1 B	C12
Works certificate according to DIN 50 049-2.2 / EN 10 204-2.2	C14
Setting upper output signal limit to 22.0 mA	D05
Acid gas version according to NACE; only with Hastelloy process diaphragm	D07
IP 68 (not with Han 7D/Han 8U plug, cable screwed gland Pg13.5 and measuring cells ≤ 914 psi)	D12
Application in zone 0 (basic device EEx ia) ³⁾	E02
Oxygen application (in oxygen measurement and inert filling liquid: 2325 psi maximum)	E10
Range to be set, specify in clear text: Y01: ... to ... mbar, psi, kPa, MPa, ... (27 characters maximum)	Y01
Tag number / description (16 characters maximum) specify in clear text:	Y15
Tag message (27 characters maximum) specify in clear text:	Y16
Setting digital display, specify in clear text: mbar, psi, kPa, MPa, ...	Y20
Factory pre-settings other than "Y01", "Y20" and "D05" are not possible.	

Notes:

¹⁾ Without cable screwed gland

³⁾ Not FM approved

²⁾ Not for "explosion proof" protection

Scope of delivery:

Transmitter as ordered, 1 brief instruction (Leporello)

Ordering example:

Position line: 7MF4033-1EA00-1AA6-Z

B-line: A01+Y01+Y20

C-line: Y01: 145 to 290 psi

C-line: Y20+D100+D36: psi

TABLE 9-2 Model 7MF4233, Model Designation

Absolute pressure, gauge construction, two-wire, series DSIII, 7MF4233-											
<u>Measuring cell filling</u>		<u>Measuring cell cleaning</u>			↑	↑	↑	↑	↑	↑	↑
Silicone oil		Normal			1						
Inert		Grease-free			3						
<u>Span</u>		<u>PN</u>									
	3.3 inH ₂ Oa	To	100 inH ₂ Oa	87 psi							
	20 inH ₂ Oa	To	525 inH ₂ Oa	145 psi							
	2.3 psia	To	72 psia	435 psi							
	14.4 psia	To	435 psia	1450 psi							
<u>Material of the wetted parts</u>											
<u>Process diaphragm</u>		<u>Parts of measuring cell</u>									
Stainless steel		Stainless steel									
Stainless steel		Hastelloy									
Hastelloy		Hastelloy									
Version for diaphragm remote seal ¹⁾											
<u>Process connection</u>											
Connection shank G 1/2 A											
Female thread 1/2-14 NPT											
Oval flange and connection shank stainless steel											
- Mounting thread 7/16-20 UNF											
Oval flange and connection shank stainless steel											
- Mounting thread M10											
<u>Material of the non-wetted parts</u>											
Housing diecast aluminum											0
Housing stainless steel precision casting											3
<u>Version</u>											
Standard version											1
International version (in preparation) plate label in English and documentation in 5 languages on CD											2
<u>Explosion protection</u>											
without explosion protection											A
with explosion protection (CENELEC):											
- Degree of protection "Intrinsic safety" (EEx ia) ⁴⁾											B
- Degree of protection "Explosion proof" (EEx d) ^{1) 4)}											D
- Degree of protection "Intrinsic safety and explosion proof" (EEx ia + EEx d) ^{1) 4)}											P
Application in zone 2 n (TÜV) ⁴⁾											E
with explosion protection (FM intrinsic safety and explosion proof) ¹⁾											H C
with explosion protection (CSA intrinsic safety and explosion proof) ¹⁾											L C
with explosion protection (FM + CSA for IS + XP)											N
<u>Electrical connection / cable inlet</u>											
Screwed gland Pg 13.5 ^{3) 4)}		(Adapter)									A
Female thread M 20 x 1.5											B
Female thread 1/2-14 NPT											C
Han 7D plug ^{3) 4)}											D
<u>Housing cover / display</u>											
without window (digital display covered, setting: mA)											1
with window (digital display visible, setting: mA)											6
with window (digital display visible, setting: as specified in Y20)											7

Notes and "Other versions" on next page.

Other versions

Add "-Z" to order number and add short spec. Transmitter with mounting bracket of: - steel - stainless steel	7MF4233 - - Z A01 A02
Han 7D plug (metal, gray) ⁴⁾	A30
Han 8U plug (instead of Han 7D) ⁴⁾	A31
Labeling of the rating plate (instead of German): - English - French - Spanish - Italian	B11 B12 B13 B14
Manufacturer test certificate M according to DIN 55 350, Part 18, and according to ISO 8402:	C11
Acceptance test certificate B according to DIN 50 049 / EN 10 204-3.1 B	C12
Works certificate according to DIN 50 049-2.2 / EN 10 204-2.2	C14
Setting of upper output signal limit to 22.0 mA	D05
Acid gas version according to NACE Only with Hastelloy process diaphragm	D07
IP 68 (not with Han 7D/Han 8U plug or cable screwed gland Pg 13.5)	D12
Application in zone 0 (basic device EEx ia) ⁴⁾	E02
Oxygen application (for oxygen measurement and inert filling liquid: 2325 psi maximum)	E10
Measuring range to be set, specify in clear text: Y01: 0 to ... mbar, psi, kPa, Mpa, ... (27 characters maximum)	Y01
Tag number / description (16 characters maximum) specify in clear text:	Y15
Tag message (27 characters maximum) specify in clear text:	Y16
Setting digital display, specify in clear text: mbar, psi, kPa, MPa, ...	Y20
Factory pre-settings other than "Y01", "Y20" and "D05" are not possible.	

Notes:

¹⁾ Version 7MF4333-1DY - Only up to a maximum span of 80 inH₂O

²⁾ Without cable screwed gland

³⁾ Not for "explosion proof" degree of protection

⁴⁾ Not FM approved

TABLE 9-3 Model 7MF4333, Model Designation

Absolute pressure, differential pressure construction, two-wire, series DSIII, 7MF4333-				-						
<u>Measuring cell filling</u>		<u>Measuring cell cleaning</u>								
Silicone oil		Normal								
Inert		Grease-free								
<u>Span</u>		<u>PN</u>								
3.3 inH ₂ Oa	To	100 inH ₂ Oa	460 psi							
20 inH ₂ Oa	To	525 inH ₂ Oa	460 psi							
2.3 psia	To	72 psia	460 psi							
14.5 psia	To	435 psia	460 psi							
77 psia	To	2320 psia	3625 psi							
<u>Material of the wetted parts (stainless steel process flanges)</u>										
<u>Process diaphragm</u>		<u>Parts of the measuring cell</u>								
Stainless steel		Stainless steel								
Hastelloy		Stainless steel								
Hastelloy		Hastelloy								
Tantalum		Tantalum								
Monel		Monel								
Gold ¹⁾		Gold								
Version for diaphragm remote seal ²⁾										
<u>Process connection</u>										
Female thread 1/4-18 NPT with flange connection										
DIN 19213 with venting opposite process connection										
- Mounting thread		M 10 ⁷⁾								
		7/16-20 UNF								
Venting on side of process flange ³⁾										
- Mounting thread		M 10								
		7/16-20 UNF								
<u>Material of the non-wetted parts</u>										
<u>Process flange screws</u>		<u>Electronics housing</u>								
Steel		Diecast aluminum								
Stainless steel		Diecast aluminum								
Stainless steel		Stainless steel precision casting								
<u>Version</u>										
Standard version										
International version (in preparation) plate label in English and documentation in 5 languages on CD										
<u>Explosion protection</u>										
without explosion protection										
with explosion protection (CENELEC):										
- Degree of protection "Intrinsic safety" (EEx ia) ⁶⁾										
- Degree of protection "Explosion proof" (EEx d) ^{4) 6)}										
- Degree of protection "Intrinsic safety and explosion proof" (EEx ia + EEx d) ^{3) 4) 6)}										
Application in zone 2 n (TÜV) ⁶⁾										
with explosion protection (FM intrinsic safety and explosion proof) ^{3) 4)}										
with explosion protection (CSA intrinsic safety and explosion proof) ^{3) 4)}										
with explosion protection (FM +CSA for IS + XP)										
<u>Electrical connection / cable inlet</u>										
Screwed gland PG 13.5 ^{5) 6)}		(Adapter)								
Female thread M 20 x 1,5										
Female thread 1/2-14 NPT										
Han 7D plug ^{5) 6)}										
<u>Housing cover / display</u>										
without window (digital display covered, setting: mA)										
with window (digital display visible, setting: mA)										
with window (digital display visible, setting: as specified in Y20)										

Notes and "Other versions" on next page.

Other versions

Add "-Z" to order number and add short specification	7MF4333 - - Z
Transmitter with mounting bracket of:	
- steel	A01
- stainless steel	A02
Process flange O-ring (instead of FPM (Viton)) of:	
- PTFE (Teflon)	A20
- FEP (with silicone core, foodstuff compatible)	A21
- FFPM (Kalrez)	A22
- NBR (buna N)	A23
Han 7D plug (metal, gray) ⁶⁾	A30
Han 8U plug (instead of Han 7D) ⁶⁾	A31
Sealing screw (1/4-18 NPT) with valve in same material as process flange	A40
Labeling of rating plate (instead of German):	
- English	B11
- French	B12
- Spanish	B13
- Italian	B14
Manufacturer test certificate M acc. to DIN 55 350, Part 18, and per ISO 8402	C11
Acceptance test certificate B acc. to DIN 50 049 / EN 10 204-3.1 B	C12
Works certificate acc. to DIN 50 049-2.2 / EN 10 204-2.2	C14
Setting of the upper output signal limit to 22.0 mA	D05
Acid gas version according to NACE: Only with Hastelloy process diaphragm and stainless steel process flange screws	D07
IP 68 (not with Han 7D/Han 8U plug or cable screwed gland Pg 13.5)	D12
Application in zone 0 (basic device EEx ia) ⁴⁾⁶⁾	E02
Side vent for gas measurement ⁴⁾	H02
Process flange:	
- without process flange	K00
- Hastelloy flange ⁷⁾	K01
- Monel flange ⁷⁾	K02
Measuring range to be set, specify in clear text:	
Y01: 0 to ... mbar, psi, kPa, MPa, ... (27 characters maximum)	Y01
Tag number / description (16 characters maximum), specify in clear text:	Y15
Tag message (27 characters maximum) specify in clear text:	Y16
Setting digital display, specify in clear text	
Analog display, specify in clear text: mbar, psi, kPa, MPa, ...	Y20
Factory pre-settings other than "Y01", "Y20" and "D05" are not possible.	

Notes:

¹⁾ Only with stainless steel process flange screws

²⁾ Version 7MF4333-1DY - Only up to a maximum span of 2.9 psi

³⁾ Not for span G, H, or K

⁴⁾ Without cable screwed gland

⁵⁾ Not with explosion proof degree of protection

⁶⁾ Not FM approved

⁷⁾ Maximum PN 2320 psi static

TABLE 9-4 Model 7MF4433, Model Designation

Differential pressure and flow transmitters, two-wire, series DSIII, PN 470/2325, 7MF4433-													
<u>Measuring cell filling</u>			<u>Measuring cell cleaning</u>			1							
Silicone oil			Normal			3							
Inert			Grease-free										
PN 460 psi, static	Span	0.4	To	8	inH ₂ O ¹⁾		B						
PN 2320 psi, static	Span	0.4	To	24	inH ₂ O		C						
		1	To	100	inH ₂ O		D						
		2.4	To	240	inH ₂ O		E						
		6.4	To	640	inH ₂ O		F						
		20	To	2000	inH ₂ O		G						
		4.3	To	435	psi		H						
<u>Material of the wetted parts (stainless steel process flanges)</u>													
<u>Process diaphragm</u>						<u>Parts of the measuring cell</u>							
Stainless steel						Stainless steel						A	
Hastelloy						Stainless steel						B	
Hastelloy						Hastelloy						C	
Tantalum ²⁾						Tantalum						E	
Monel ²⁾						Monel						H	
Gold ^{2), 3)}						Gold						L	
Version for diaphragm remote seal												Y	
<u>Process connection</u>													
Female thread 1/4-18 NPT and flange connection acc. to DIN 19 213													
Venting opposite process connection:													
- Mounting thread M 10													0
- Mounting thread 7/16-20 UNF													2
Venting on side of process flanges:													
- Mounting thread M 10 ⁷⁾													4
- Mounting thread 7/16-20 UNF ⁷⁾													6
<u>Material of the non-wetted parts</u>													
<u>Process flange screws</u>						<u>Electronics housing</u>							
Steel						Diecast aluminum						0	
Stainless steel						Diecast aluminum						2	
Stainless steel						Stainless steel precision casting						3	
<u>Version</u>													
Standard version													1
International version (in preparation) plate label in English and documentation in 5 languages on CD													2
<u>Explosion protection</u>													
without explosion protection													A
with explosion protection (GENELEC):													
- Degree of protection "Intrinsic safety" (EEx ia) ⁶⁾													B
- Degree of protection "Explosion proof" (EEx d) ^{1) 6)}													D
- Degree of protection "Intrinsic safety and explosion proof" (EEx ia + EEx d) ^{1) 6)}													P
Application in zone 2 n (TÜV) ⁶⁾													E
with explosion protection (FM intrinsic safety and explosion proof) ¹⁾													H
with explosion protection (CSA intrinsic safety and explosion proof) ¹⁾													C
with explosion protection (FM + CSA for IS + XP)													L
													C
													N
<u>Electrical connection / cable inlet</u>													
Screwed gland PG 13.5 ^{5) 6)} (Adapter)													A
Female thread M 20 x 1.5													B
Female thread 1/2-14 NPT													C
Han 7D plug ^{5) 6)}													D
<u>Housing cover / display</u>													
without window (digital display covered, setting: mA)													1
with window (digital display visible, setting: mA)													6
with window: digital display visible, setting: as specified in Y20													7

Notes and "Other versions" on next page.

Other versions

Add "-Z" to order number and add short spec.	7MF4433 - - - Z
Transmitter with mounting bracket of:	
- steel	A01
- stainless steel	A02
Process flange O-ring (instead of FPM (Viton)) of:	
- PTFE (Teflon)	A20
- FEP (with silicone core, foodstuff compatible)	A21
- FFKM (Kalrez)	A22
- NBR (buna N)	A23
Han 7D plug ⁶⁾	A30
Han 8U plug (instead of Han 7D) ⁶⁾	A31
Sealing screws (1/4-18 NPT) with valve in same material as process flanges	A40
Labeling of rating plate (instead of German):	
- English	B11
- French	B12
- Spanish	B13
- Italian	B14
Manufacturer test certificate M acc. To DIN 55350, Part 18, and acc. to ISO 8402	C11
Acceptance test certificate B acc. to DIN 50 049 / EN 10 204-3.1 B	C12
Works certificate acc. To DIN 50 049-2.2 / EN 10 204-2.2	C14
Setting the upper output current limit to 22.0 mA	D05
Acid gas version acc. To NACE only with Hastelloy process diaphragm and stainless steel process flange screws	D07
IP 68 (not with Han 7D/Han 8U plug and cable screwed gland Pg 13.5)	D12
Application in zone 0 (basic device EEx ia) ⁶⁾	E02
Overfill protection for combustible and non-combustible liquids (PN 470 psi maximum) (basic device EEx ia)	E08
Oxygen application (for oxygen measurement and inert liquid: 2325 psi maximum)	E10
Switching the process connection side (HP side: left, LP side: right)	H01
Lateral vent for gas measurement	H02
Stainless steel process flanges for vertical active pressure lines (not with supplements K01 or K02)	H03
Process flanges:	
- without process flanges	K00
- Hastelloy flanges	K01
- Monel flanges	K02
Measuring range to be set, specify in clear text,	
For linear characteristic: ... to ... mbar, psi, kPa, MPa, ... (27 characters maximum)	Y01
For square root characteristic: 0 to ... mbar, psi, kPa, MPa, ... (27 characters maximum)	Y02
Tag number / description (16 characters maximum) specify in clear text:	Y15
Tag message (27 characters maximum) specify in clear text:	Y16
Setting digital display specify in clear text: mbar, psi, kPa, MPa, ...	Y20
Factory presettings other than "Y01" or "Y02", "Y20" and "D05" are not possible.	

Notes:

- ¹⁾ Not suitable for remote process mounting
- ²⁾ Only with span D, F, G, or H
- ³⁾ For stainless steel process flange screws
- ⁴⁾ Without cable screwed gland

Scope of delivery:

Transmitter as ordered, 1 brief instruction (Leporello)
2 sealing screws (same material as process flange)

⁵⁾ Not for "explosion proof" degree of protection

⁶⁾ Not FM approved

⁷⁾ Not with K01 or K02

Ordering example:

Position line: 7MF9933-1DA00-1AA1-Z

B-line: A01+B11+C14+Y01+Y15

C-line: Y01: 50...150 inH₂O

C-line: Y15: PIC 1758

TABLE 9-5 Model 7MF4533, Model Designation

Differential pressure and flow transmitter, two-wire, series DSIII, Model 7MF4533-	1								
PN 6090 psi									
<u>Span</u>									
1.0 To 100 InH ₂ O		D							
2.4 To 240 InH ₂ O		E							
6.4 To 640 InH ₂ O		F							
20 To 2000 InH ₂ O		G							
4.3 To 435 psi		H							
<u>Material of the wetted parts (stainless steel process flanges)</u>									
<u>Process diaphragm</u>									
Stainless steel						A			
Hastelloy						B			
Gold ¹⁾						L			
<u>Process connection</u>									
Female thread 1/4-18 NPT and flange connection, DIN 19 213, Venting opposite process connection:									
- Mounting thread M12									
- Mounting thread 7/16-20 UNF									
							1		
							3		
<u>Material of the non-wetted parts</u>									
<u>Process flange screws</u>									
Steel							0		
Stainless steel (≤ PN 4569 psi)							2		
Stainless steel (≤ PN 4569 psi)							3		
<u>Version</u>									
Standard version									
							1		
International version (in preparation) plate label in English and documentation in 5 languages on CD									
							2		
<u>Explosion protection</u>									
without explosion protection									
								A	
with explosion protection (CENELEC)									
Degree of protection "Intrinsic safety" (EEx ia) ⁴⁾									
								B	
Degree of protection "Explosion proof" (EEx d) ²⁾⁴⁾									
								D	
Degree of protection "Intrinsic safety and explosion proof" (EEx ia + EEx d) ²⁾⁴⁾									
								P	
Application in zone 2 n (TÜV) ⁴⁾									
								E	
with explosion protection (FM intrinsic safety and explosion proof) ²⁾									
								H	C
with explosion protection (CSA intrinsic safety and explosion proof) ²⁾									
								L	C
with explosion protection (FM + CSA for IS + XP)									
								N	
<u>Electrical connection / cable inlet</u>									
Screwed gland PG 13.5 ³⁾⁴⁾ (Adapter)									
								A	
Female thread M 20 x 1.5									
								B	
Female thread ½-14 NPT									
								C	
Han 7D plug ³⁾⁴⁾									
								D	
<u>Housing cover / Display</u>									
without window (digital display covered, setting: mA)									
								1	
with window (digital display visible, setting: mA)									
								6	
with window (digital display visible, setting: as specified in Y20)									
								7	

Notes on next page; "Other versions" below and continued on next page.

Other versions

Add "-Z" to order number and add short spec.

7MF4533 - -Z

Transmitter with mounting bracket of:

- steel

A01

- stainless steel

A02

Process flange O-ring (instead of FPM (Viton)) of:

Other versions

- PTFE (Teflon)	A20
- FEP (with silicone core, foodstuff compatible)	A21
- FFPM (Kalrez)	A22
- NBR (buna N)	A23
Han 7D plug (metal, gray) ⁴⁾	A30
Han 8U plug (instead of Han 7D) ⁴⁾	A31
Sealing screw (1/4-18 NPT) with valve in the same material as the process flanges	A40
Labeling of the rating plate (instead of German):	
- English	B11
- French	B12
- Spanish	B13
- Italian	B14
Manufacturer test certificate M according to DIN 55350, Part 18, and according to ISO 8402	C11
Acceptance test certificate B according to DIN 50 049 / EN 10 204-3.1 B	C12
Works certificate according to DIN 50 049-2.2 / EN 10 204-2.2	C14
Setting the upper output signal limit to 22.0 mA	D05
Acid gas version according to NACE, only with Hastelloy process diaphragm and stainless steel process flanges, PN 4569 psi maximum	D07
Stainless steel process flange screws, PN 6090 psi, basic device with machined stainless steel process flange screws	D09
IP 68 (not with Han 7D/Han 8U plug and cable screwed gland Pg 13.5)	D12
Application in zone 0 (basic device EEx ia) ⁴⁾	E02
Switching the process connection side	H01
Lateral vent for gas measurement	H02
Stainless steel process flanges for vertical active pressure lines	H03
Measuring range to be set, specify in clear text, For linear characteristic: ... to ... mbar, psi, kPa, MPa, ... (27 characters maximum)	Y01
For square root characteristic: 0 to ... mbar, psi, kPa, MPa, ..(27 characters maximum)	Y02
Tag number / description (16 characters maximum) specify in clear text:	Y15
Tag message (27 characters maximum) specify in clear text:	Y16
Setting digital display, specify in clear text: mbar, psi, kPa, MPa, ...	Y20
Factory pre-settings other than "Y01" or "Y02", "Y20" or "D05" are not possible.	

Notes:

¹⁾ Only with span D, F, G, or H; maximum PN 4569 psi and only with stainless steel process flange screws

²⁾ Without cable screwed gland

³⁾ Not with "explosion proof" degree of protection

⁴⁾ Not FM approved

Scope of delivery: Transmitter as ordered, 1 brief instruction (Leporello)

2 sealing screws (same material as process flanges)

Ordering example:

Position line: 7MF4533-1DA10-1AA1-Z

B-line: Y01

C-line: Y01: 36.1... 57.4 inH₂O

TABLE 9-6 Models 7MF4633 and 7MF4912, Model Designation

Flanged level transmitter, two-wire, series DSIII, 7MF4633-	1	Y	-
<u>Span</u>	↑	↑	↑
10.0 To 100 inH ₂ O	D		
10.0 To 240 inH ₂ O	E		
20 To 640 inH ₂ O	F		
64 To 2000 inH ₂ O	G		
<u>Process connection of low pressure side</u>			
Female thread 1/4-18 NPT and flange connection DIN 19 213 with mounting thread:			
- M 10		0	
- 7/16-20 UNF		2	
<u>Material of the non-wetted parts</u>			
<u>Process flange screws</u>			
Steel			0
Stainless steel			2
Stainless steel			3
<u>Electronics housing</u>			
Diecast aluminum			0
Diecast aluminum			2
Fine precision stainless steel			3
<u>Version</u>			
Standard version			1
International version (in preparation) plate label in English and documentation in 5 languages on CD			2
<u>Explosion protection</u>			
without explosion protection			A
with explosion protection (CENELEC):			
- Degree of protection "Intrinsic safety" (EEx ia) ³⁾			B
- Degree of protection "Explosion proof" (EEx d) ^{1) 3)}			D
- Degree of protection "Intrinsic safety and explosion proof" (EEx ia + EEx d) ^{1) 3)}			P
Application in zone 2 n (TÜV) ³⁾			E
with explosion protection (FM intrinsic safety and explosion proof) ¹⁾			H
with explosion protection (CSA intrinsic safety and explosion proof) ¹⁾			L
with explosion protection (FM + CSA for IS + XP)			N
<u>Electrical connection / Cable inlet</u>			
Screwed gland PG 13.5 ^{2) 3)} (Adapter)			A
Female thread M 20 x 1,5			B
Female thread 1/2-14 NPT			C
Han 7D plug ^{2) 3)}			D
<u>Housing cover / Display</u>			
without window (digital display covered, setting: mA)			1
with window (digital display, setting: mA)			6
with window (digital display visible, setting: as specified in Y20)			7

Notes, "Other versions," and Model 7MF4912 on next two pages.

Other versions

Add "-Z" to order number and add short spec.	7MF4633 - -Z
Han 7D plug (metal, gray) ³⁾	A30
Han 8U plug (instead of Han 7D) ³⁾	A31
Sealing screw (1/4-18 NPT) with valve in same material as process flanges	A40
Labeling of rating plate (instead of German):	
- English	B11
- French	B12
- Spanish	B13
- Italian	B14
Manufacturer test certificate M acc. To DIN 55350, Part 18, and ISO 8402	C11
Acceptance test certificate B acc. to DIN 50 049 / EN 10 204-3.1 B	C12
Works certificate acc. to DIN 50 049-2.2 / EN 10 204-2.2	C14
Setting the upper limit of the output signal to 22.0 mA	D05
IP 68 (not with Han 7D/Han 8U plug and cable screwed gland Pg 13.5)	D12
Application in zone 0 (basic device EEx ia) ³⁾	E02
Overfill protection for combustible and non-combustible liquids (maximum PN 32 psi) (basic device EEx ia)	E08
Switching the process connection side (HP side: left, LP side: right)	H01
Specify meas. range to be set in clear text, Y01: ... to ... mbar, bar, kPa, Mpa, ... (27 characters maximum)	Y01
Specify tag number / description (16 characters maximum) in clear text:	Y15
Specify tag message (27 characters maximum) in clear text:	Y16
Specify setting digital display in clear text: mbar, bar, kPa, MPa, ...	Y20

Factory presettings other than "Y01", "Y20" and "D05" are not possible.

Notes:

¹⁾ Without cable screwed gland

²⁾ Not with "explosion proof" degree of protection

³⁾ Not FM approved

Scope of delivery:

Transmitter as ordered, 1 brief instruction (Leporello)

1 sealing screw (same material as process flange)

Order example:

Pos. 1 Position line: 7MF4633-1DY10-1AA1-Z
 B-line: Y01
 C-line: Y01: 1.3 to 2.1 inH₂O
 Pos. 2 Position line: 7MF4912-3DA11

Flanged Level Transmitter Accessories			Order number				
Mounting flange, mounted directly on transmitter, two-wire, 7MF4912-			3				
<u>Flange</u>	<u>Nominal diameter</u>	<u>Nominal pressure</u>					
Connection per	DN 80	PN 40 psi					
DIN 2501	DN 100	PN 16 psi					
		PN 40 psi					
Connection per	3 inch	150 lb/sq. in.					
ANSI B 16.5		300 lb/sq. in.					
	4 inch	150 lb/sq. in.					
		300 lb/sq. in.					
Special version according to customer specifications							
<u>Material of wetted parts</u>							
Stainless steel M.-No. 1.4571:							
Without foil, uncoated							
With PTFE foil ¹⁾							
With ECTFE coating ¹⁾							
With PFA coating ¹⁾							
Monel 400, W.-No. 2.4360							
Hastelloy B2, W.-No. 2.4617							
Hastelloy C276, W.-No. 2.4819							
Tantalum							
Hastelloy C4, W.-No. 2.4610							
Special version to customer specifications							
Smooth processing face according to DIN 2526, Form D:							
<u>Tube length</u> ²⁾	Flush mount						
	2" / 50 mm						
	4" / 100 mm						
	6" / 150 mm						
	8" / 200 mm						
<u>Filling liquid</u>							
Silicone oil M5							
Special version to customer specifications							

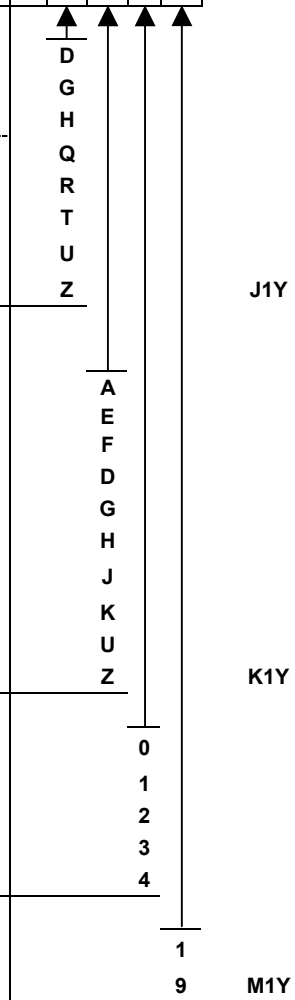

Other versions for mounting flange	
Add "-Z" to the order number and add short spec.	7MF4912 - -Z
With flame barrier for mounting in zone 0 (with documentation)	A01
Manufacturer test certificate M acc. to DIN 55 350, Part 18, and ISO 8402 (not with supplement "P01")	C11
Acceptance test certificate B according to DIN 50 049; see Section 3.1 and EN 10 204	C12
Vacuum-proof version (use in vacuum pressure range)	V04
Calculation of span of the corresponding transmitter, enclose completed questionnaire! (Not with supplement "P01.")	Y05

Notes:

¹⁾ For vacuum on request

²⁾ Prices for the stated tube lengths are based on the material of the wetted part: stainless steel M. No. 1.4571. Prices for other materials are available upon request.

TABLE 9-7 Measuring Cells for Pressure, Service Parts

DS III and DS III PA series, 7MF4990-								0
<u>Measuring cell filling</u>		<u>Measuring cell cleaning</u>		↑	↑	↑	↑	
Silicon oil		Normal		1				
Inert		Grease-free		3				
<u>Nominal measuring range</u>		<u>PN</u>						
	0.15 To	15 psi	87 psi		B			
	0.60 To	60 psi	145 psi		C			
	2.3 To	230 psi	460 psi		D			
	9.25 To	925 psi	1450 psi		E			
	23 To	2320 psi	3625 psi		F			
	58 To	5800 psi	8700 psi		G			
<u>Wetted parts materials</u>								
<u>Seal diaphragm</u>		<u>Connection shank</u>						
Stainless steel		Stainless steel			A			
Hastelloy		Stainless steel			B			
Hastelloy		Hastelloy			C			
<u>Process connection</u>								
Connection shank G1/2 A								0
Female thread 1/2-14 NPT								1
Oval flange and stainless steel connection shank, maximum span: 2320 psi								
- Mounting thread 7/16-20 UNF								2
- Mounting thread M10								3

TABLE 9-8 Measuring Cells for Absolute Pressure, Gauge Construction, Service Parts

DS III and DS III PA series, Gauge Construction, 7MF4992-								0
<u>Measuring cell filling</u>		<u>Measuring cell cleaning</u>		↑	↑	↑	↑	
Silicon oil		Normal		1				
Inert		Grease-free		3				
<u>Nominal measuring range</u>		<u>PN</u>						
	3.3 inH ₂ Oa To	100 inH ₂ Oa	87 psi		D			
	20 inH ₂ Oa To	525 inH ₂ Oa	145 psi		F			
	2.3 psia To	72 psia	435 psi		G			
	14.4 psia To	435 psia	1450 psi		H			
<u>Wetted parts materials</u>								
<u>Seal diaphragm</u>		<u>Connection shank</u>						
Stainless steel		Stainless steel			A			
Hastelloy		Stainless steel			B			
Hastelloy		Hastelloy			C			
<u>Process connection</u>								
Connection shank G1/2 A								0
Female thread 1/2-14 NPT								1
Oval flange and stainless steel connection shank, maximum 2320 psia								
- Mounting thread 7/16-20 UNF								2
- Mounting thread M10								3

TABLE 9-9 Measuring Cells for Absolute Pressure, Differential Const., Service Parts

DS III and DS III PA series, Differential Construction, 7MF4993-							
<u>Measuring cell filling</u>	<u>Measuring cell cleaning</u>		▲	▲	▲	▲	▲
Silicon oil	Normal		1				
Inert	Grease-free		3				
<u>Nominal measuring range</u>		<u>PN</u>					
3.3 inH ₂ Oa To	100 inH ₂ Oa	460 psi		D			
20 inH ₂ Oa To	525 inH ₂ Oa	460 psi		F			
2.3 psia To	72 psia	460 psi		G			
14.4 psia To	435 psia	460 psi		H			
77 psia To	2320 psia	3625 psi		K	E		
<u>Wetted parts materials (stainless steel process flanges)</u>							
<u>Seal diaphragm</u>	<u>Parts of measuring cell</u>						
Stainless steel	Stainless steel				A		
Hastelloy	Stainless steel				B		
Hastelloy	Hastelloy				C		
Tantalum	Tantalum				E		
Monel	Monel				H		
Gold ¹⁾	Gold				L		
<u>Process connection</u>							
Female thread 1/4-18 NPT with flange connection to DIN 19213 with:							
Sealing screw opposite process connection							
- Mounting thread M10 ²⁾						0	
- Mounting thread 7/16-20 UNF						2	
Sealing screw on side of process flange ³⁾							
- Mounting thread M10						4	
- Mounting thread 7/16-20 UNF						6	
<u>Non-wetted parts materials</u>							
<u>Process flange screws</u>							
Steel							0
Stainless steel							2

¹⁾ Only with stainless steel process flange screws
²⁾ Maximum PN 2320 psi static
³⁾ Not for spans G, H, or K

Other versions

Add "Z" to the order number and the specify order code	7MF4993-.....- Z
Process flange O-ring (instead of FPM (Viton)) made of:	
- PTFE (Teflon)	A20
- FEP (with silicone core, approved for foodstuffs)	A21
- FFPM (Kalrez)	A22
- NBR (Buna N)	A23
Remote seals; not with K01, K02 or K04	D20
Vent on side for gas measurements	H02
Without process flange	K00
Process flange made of:	
- Hastelloy	K01
- Monel	K02
- Stainless steel with PVDF insert	K04

TABLE 9-10 Measuring Cells for Pressure and Flow, Differential Const., Service Parts

DS III and DS III PA series, differential construction, 7MF4994-						
<u>Measuring cell filling</u>	<u>Measuring cell cleaning</u>	▲	▲	▲	▲	▲
Silicon oil	Normal	1				
Inert	Grease-free	3				
<u>Nominal measuring range</u>						
PN 460 psi, static	span 0.4 To 8 inH ₂ O ¹⁾		B			
PN 2320 psi, static	span 0.4 To 24 inH ₂ O		C			
	1 To 100 inH ₂ O		D			
	2.4 To 240 inH ₂ O		E			
	6.4 To 640 inH ₂ O		F			
	20 To 2000 inH ₂ O		G			
	4.3 To 435 psi		H			
<u>Wetted parts materials (stainless steel process flanges)</u>						
<u>Seal diaphragm</u>	<u>Parts of measuring cell</u>					
Stainless steel	Stainless steel		A			
Hastelloy	Stainless steel		B			
Hastelloy	Hastelloy		C			
Tantalum ²⁾	Tantalum		E			
Monel ²⁾	Monel		H			
Gold ^{2) 3)}	Gold		L			
<u>Process connection</u>						
Female thread 1/4-18 NPT with flange connection to DIN 19213 with:						
Sealing screw opposite process connection						
- Mounting thread M10					0	
- Mounting thread 7/16-20 UNF					2	
Sealing screw on side of process flange						
- Mounting thread M10 ⁴⁾					4	
- Mounting thread 7/16-20 UNF ⁴⁾					6	
<u>Non-wetted parts materials</u>						
<u>Process flange screws</u>						
Steel						0
Stainless steel						2
¹⁾ Not for remote seal connection						
²⁾ Only with span D, F, G, or H						
³⁾ Only with stainless steel process flange screws						
⁴⁾ Not with K01 or K02						

Other versions

Add "Z" to the order number and the specify order code	7MF4994-.....- Z
Process flange O-ring (instead of FPM (Viton)) made of:	
- PTFE (Teflon)	A20
- FEP (with silicone core, approved for foodstuffs)	A21
- FFPM (Kalrez)	A22
- NBR (Buna N)	A23
Remote seals; not with K01, K02 or K04	D20
Vent on side for gas measurements	H02
Process flanges of stainless steel for vertical differential lines; not with K01, K02 or K04	H03
Process flanges:	
- without process flanges	K00
- Hastelloy flanges	K01
- Monel flanges	K02
- Stainless steel, with PVDF insert, flanges	K04

TABLE 9-11 Measuring Cells for Differential Pressure and Flow, Service Parts

DS III and DS III PA series, differential construction, 7MF4995			1				
<u>Nominal measuring range</u>							
		<u>PN</u>		▲	▲	▲	▲
1.0 To	100 inH ₂ O	6090 psi		D			
2.4 To	240 inH ₂ O	6090 psi		E			
6.4 To	640 inH ₂ O	6090 psi		F			
20 To	2000 inH ₂ O	6090 psi		G			
4.3 To	435 psi	6090 psi		H			
<u>Wetted parts materials</u>							
<u>Seal diaphragm</u>		<u>Parts of measuring cell</u>					
Stainless steel		Stainless steel			A		
Hastelloy		Stainless steel			B		
Gold ¹⁾		Gold			L		
<u>Process connection</u>							
Female thread 1/4-18 NPT with flange connection to DIN 19213 with: Sealing screw opposite process connection							
- Mounting thread M12						1	
- Mounting thread 7/16-20 UNF						3	
<u>Non-wetted parts materials</u>							
<u>Process flange screws</u>							
Steel							0
Stainless steel (<PN 4569 psi)							2

¹⁾ Only with span D, F, G, or H. Maximum PN 4569 psi only with stainless steel process flange screws

Other versions

Add "Z" to the order number and the specify order code	7MF4995-.....- Z
Process flange O-ring (instead of FPM (Viton)) made of:	
- PTFE (Teflon)	A20
- FEP (with silicone core, approved for foodstuffs)	A21
- FFPM (Kalrez)	A22
- NBR (Buna N)	A23
Process flange screws machined from stainless steel for PN 6090 psi	D09
Vent on side for gas measurements	H02
Process flanges of stainless steel for vertical differential lines	H03
Without process flange	K00

TABLE 9-12 Measuring Cells for Filling Level, Service Parts

DS III and DS III PA series, 7MF4996	1				
<u>Nominal measuring range</u>		▲	▲	▲	▲
10.0 To 100 inH ₂ O		D			
10.0 To 240 inH ₂ O		E			
20 To 640 inH ₂ O		F			
64 To 2000 inH ₂ O		G			
<u>Wetted parts materials (stainless steel process flanges)</u>					
<u>Seal diaphragm</u>	Parts of measuring cell				
Stainless steel	Stainless steel		A		
<u>Process connection, minus side</u>					
Female thread 1/4-18 NPT with flange connection to DIN 19213 with:					
- Mounting thread M10				0	
- Mounting thread 7/16-20 UNF				2	
<u>Non-wetted parts materials</u>					
<u>Process flange screws</u>					
Steel					0
Stainless steel					2

Other versions

Add "Z" to order number and specify order code	7MF4996-.....- Z
Process flange O-ring (instead of FPM (Viton)) made of:	
- PTFE (Teflon)	A20
- FEP (with silicone core, approved for foodstuffs)	A21
- FPM (Kalrez)	A22
- NBR (Buna N)	A23

TABLE 9-13 Electronics and Connecting Boards, Service Parts

Product description	Order Number
SITRANS P DS III electronics module	7MF4997-1DK
SITRANS P DS III terminal board (for field terminal connections)	7MF4997-1DN
SITRANS P DS III digital display	7MF4997-1BQ

9.2 ACCESSORIES

The following table lists many of the available accessories. Additional information about many transmitter accessories can be found in PI34-3, XTC Transmitter Accessory Guide.

TABLE 9-14 Accessories

DESCRIPTION	MODEL 7MF			PART NUMBER
	4433, 4533	4033, 4233, 4333	7633, 4912	
Three-Valve Manifold, Steel*	Y	N	N	16275-252
Three-Valve Manifold, 316 SS*	Y	N	N	16275-251
Transient Suppressor*	Y	Y	Y	14999-287
General Purpose Power Supply, 24 Vdc, 2A*	Y	Y	Y	15124-1
Field Mounted Power Supply, 28 Vdc, 125 mA*	Y	Y	Y	16055-299
Model 275 Universal HART Communicator	Y	Y	Y	275D9EI5B0100
Model 375 Field Communicator	Y	Y	Y	375HR1EKL

*Refer to GCMC-1, Measurement & Control Product Catalog, for additional details.

Y = For use with transmitter model in table column head; N = not for use.

9.3 SPECIFICATIONS

The following specifications are for all transmitter models except as noted. Table 9-15 is for Pressure and Differential Pressure models. Table 9-16 is for Absolute Pressure and Filling Level models.

TABLE 9-15 Specifications, Pressure and Differential Pressure Models

Device type:	Pressure 7MF4033	Differential pressure 7MF4433 / 7MF4533
Application range	See Table 9-17	See Table 9-18
Function	Piezoresistive	
Measurement principle	Piezoresistive	
Input	Pressure	Differential pressure and flow
Measurement variable	Pressure	Differential pressure and flow
Measurement range	0.15 to 5800 psi (6 ranges)	0.4 to 8 inH ₂ O (1 range) 0.4 inH ₂ O to 435 psi (6 ranges) 1 inH ₂ O to 435 psi (5 ranges)
<ul style="list-style-type: none"> Span (continuously adjustable) <ul style="list-style-type: none"> Nominal pressure (PN) 470 psi Nominal pressure (PN) 2325 psi Nominal pressure (PN) 6090 psi Lower measurement limit <ul style="list-style-type: none"> - 435 psi measuring cell - Measuring cell with silicone oil filling - Measuring cell with inert filling liquid <ul style="list-style-type: none"> for process temp. -20 °C < ϑ < 60 °C for process temp. +60 °C < ϑ < 100 °C (maximum +85°C for 435 psi meas. cell) Upper measurement limit Start of scale (continuously adjustable) 	12 inH ₂ O (absolute) 12 inH ₂ O (absolute) 12 inH ₂ O (abs) + 8 inH ₂ O (abs) · ((ϑ - 60 °C) / °C)	-100% of maximum span -33 % of maximum span 12 inH ₂ O (absolute)
<ul style="list-style-type: none"> Upper measurement limit Start of scale (continuously adjustable) 	+100 % of maximum span, (maximum 2325 psi in oxygen measurement and inert filling liquid 2325 psi) Between the measuring limits	
Output	4 to 20 mA	
Output signal	3.55 mA, factory set to 3.84 mA	
<ul style="list-style-type: none"> Lower limit (continuously adjustable) Upper limit (continuously adjustable) Ripple (without HART communication) Electric damping <ul style="list-style-type: none"> - adjustable time constants (T₆₆) 	23.0 mA, factory set 20.5 mA or optionally 22.0 mA $I_{pp} \leq 0.5\%$ of maximum output current 0 to 100 s, in steps of 0.1 s, factory set to 0.1 s	
<ul style="list-style-type: none"> Current transmitter Failure signal 	Adjustable 3.55 to 23 mA Adjustable 3.55 to 23 mA	
Load	$R_B \leq (U_H - 10.5 \text{ V}) / 0.023 \text{ A}$ in Ω , U _H : power supply in V $R_B = 230$ to 500Ω (HART-Communicator) or $R_B = 1100\Omega$ (HART-Communicator)	
<ul style="list-style-type: none"> without HART communication with HART communication 		
Characteristic	Linear forward or reverse acting or square root forward	
Measuring accuracy		
Reference conditions	Forward acting, zero based, process diaphragm stainless steel; for flange level flush mount, silicone oil filling and room temperature 25 °C $r = \text{maximum span} / \text{set span} = \text{span ratio}$	

Device type:	Pressure 7MF4033	Differential pressure 7MF4433 / 7MF4533
Measurement error (limit point setting, including hysteresis and repetitive accuracy) ● linear characteristic $r \leq 10$ $10 < r \leq 30$ $30 < r \leq 100$		$\leq 0.1 \%$ $\leq 0.2 \%$ $\leq (0.005 \cdot r + 0.05) \%$
● Square root characteristic Flow > 50% Flow 25 to 50%		$\leq 0.1 \%$ at $r \leq 10$ $\leq 0.2 \%$ at $10 < r \leq 30$ $\leq 0.2 \%$ at $r \leq 10$ $\leq 0.4 \%$ at $10 < r \leq 30$
● Repetitive accuracy ● Hysteresis	Contained in measuring error	
Transient time (T_{63} , without electrical damping)	About 0.2 s	About 0.2 s, about 0.3 s with 8 and 24 inH ₂ O meas. cell
Long-term drift over 12 months 8 inH ₂ O meas. cell:		$\leq (0.1 \cdot r) \%$ $\leq (0.2 \cdot r) \%$
Influence of ambient temperature ● at -10 to +60 °C ● at -40 to -10 °C and +60 to +85 °C		$\leq (0.1 \cdot r + 0.2) \%$ ¹⁾ ¹⁾ double value with 8 inH ₂ O measuring cell $\leq (0.1 \cdot r + 0.15) \%$ / 10 K ¹⁾ ¹⁾ double value with 8 inH ₂ O measuring cell
Influence of static pressure ● on zero 8 inH ₂ O meas. cell ● on the span 8 inH ₂ O meas. cell		$\leq (0.15 \cdot r) \%$ per 1450 psi $\leq (0.15 \cdot r) \%$ per 464 psi $\leq 0.2\%$ per 1450 psi $\leq 0.2\%$ per 464 psi
Influence of installation position	≤ 0.2 inH ₂ O per 10° angle	≤ 0.28 inH ₂ O per 10° angle
Influence of power supply	0.005 % per 1V change in voltage	
Operating conditions		
Installation conditions ● Installation note	Process connection vertically downwards	Any
Ambient conditions ● Ambient temperature (in hazardous zones note temperature class) measuring cell - Measuring cell with silicon oil fill. Span 435 psi at PN 6174 psi - Meas. cell with inert filling liquid - Digital display		-40 to +85 °C (-40 to +185°F) -20 to +85 °C (-4 to +185°F)
● Ambient temperature limit ● Storage temperature ● Climate class - Condensation		see ambient temperature -30 to +85 °C (-22 to +185°F) Permissible
● Degree of protection (EN 60 529) ● EMC - Spurious emission - Interference resistance		IP 65 EN 50 081-1 EN 50 082-2 and NAMUR NE 21

Device type:	Pressure 7MF4033	Differential pressure 7MF4433 / 7MF4533
Process conditions		
<ul style="list-style-type: none"> Process temperature <ul style="list-style-type: none"> - Measuring cell with silicon oil fill. Span 435 psi at PN 6174 psi 	-40 to +100 °C (-40 to +212°F)	-20 to +85 °C (-4 to +185°F)
<ul style="list-style-type: none"> - Measuring cell with inert filling liquid Span 435 psi 	-20 to +100 °C (-4 to +212°F)	-20 to +85°C (-4 to +185°F)
<ul style="list-style-type: none"> Process temperature limit Process pressure limit 	see Table 9-10	see process temperature Nominal pressure (PN); see Table 9-11
Constructional design		
Weight (without options) Transmitter with mounting flange without tube	About 3.3 lbs (1.5 kg)	About 8.8 lbs (4 kg)
Dimensions	see Figure 9-1	see Figures 9-2 and 9-3
Material		
<ul style="list-style-type: none"> Material of wetted parts <ul style="list-style-type: none"> - Connection shank - Oval flange - Process diaphragm 	Stainless steel, M.-No. 1.4401 or Hastelloy C4, M.- No. 2.4610 Stainless steel, M.-No. 1.4401	
<ul style="list-style-type: none"> - Process flanges and sealing screw 	Stainless steel, M.-No. 1.4404 or Hastelloy C276, M.- No. 2.4819	Monel, M.-No. 2.4360 Tantalum or gold
<ul style="list-style-type: none"> - O-ring 		Stainless steel, W.-No. 1.4408, Hastelloy C4, W.-No. 2.4610 or Monel, W.-No. 2.4360
<ul style="list-style-type: none"> Material of non-wetted parts <ul style="list-style-type: none"> - Electronics housing - Process flange screws - Mounting bracket (optional) 	Low copper diecast aluminum GD-ALSi 12, polyester-based varnish or stainless steel precision casting, stainless steel rating plate	Steel, galvanized, yellow- chromed or stainless steel
Meas. cell filling	Silicone oil filling or inert liquid (maximum pressure 2325 psi for oxygen measurement)	
Process connection	Connection shank G $\frac{1}{2}$ A DIN 16 288, female thread $\frac{1}{2}$ -14NPT or oval flange maximum range 2325 psi with mounting thread M10 / M12 or 7/16 -20 UNF	Female thread 1/4 - 18 NPT and Flange connection DIN 19213 with mounting thread M10 (PN 2325 psi) M12 or 7/16 -20 UNF
Electrical connection	Screw terminals, cable inlet or screwed gland Pg 13.5 (adapter), M20 x 1.5 or $\frac{1}{2}$ - 14 NPT, or Han 7D/Han 8U plug	
Display and user interface		
Input keys Digital display	3 pushbuttons on the device for local programming Installed, cover with window (optional)	
Power supply (U_H) Terminal voltage at the transmitter	DC 10.5V to 45V or	

Device type:	Pressure 7MF4033	Differential pressure 7MF4433 / 7MF4533
Ripple Noise	DC 10.5V to 30 V in intrinsically safe operation $U_{pp} \leq 0.2 \text{ V}$ (47 to 125 Hz) $U_{eff} \leq 1.2 \text{ mV}$ (0.5 to 10 kHz)	
<p>Certificates and licenses</p> <p>CENELEC</p> <ul style="list-style-type: none"> ● Intrinsic safety <ul style="list-style-type: none"> - EC test certificate - Max. ambient temperature - Connection to certified intrinsically safe circuits with the maximum values - Active internal inductance - Active internal capacitance ● Explosion proof <ul style="list-style-type: none"> - Certificate of conformity - Max. ambient temperature ● Ex-tested zone 2n <ul style="list-style-type: none"> - Registration number <p>FMRC (Factory Mutual Research Corp.)</p> <ul style="list-style-type: none"> ● Intrinsic safety and explosion proof ● Explosion proof ● Dust-ignition proof ● Intrinsically safe ● Entity parameters <p>CSA (Certificate of Compliance)</p>	<p>The specifications in the official EC test certificate and the applicable supplements are exclusively valid</p> <p>DIN EN 50 014: 1997, EN 50 020: 1994 and EN 50 284: 1999 Ex II 1/2 G EEx ia IIC T4 / T5 / T6 PTB 99 ATEX 2122</p> <p>+85 °C temperature class T4, +70 °C temperature class T5, +60 °C temperature class T6</p> <p>$U_i = 30 \text{ V}$, $I_i = 100 \text{ mA}$, $P_i = 750 \text{ mW}$ $R_i = 300 \Omega$</p> <p>$L_i = 1 \text{ mH}$ $C_i = 6 \text{ nF}$ available available consult factory consult factory consult factory</p> <p>3008490 (3610, 3615) For class I, division 1, groups A, B, C, and D For class II, division 1, groups E, F, and G, indoor and outdoor (NEMA 4X) hazardous (classified) locations With entity, for use in class I, division 1, groups A, B, C, D, E, F, and G, indoor and outdoor (NEMA 4X) hazardous (classified) locations $V_{max} = 30\text{V}$; $I_{max} = 100 \text{ mA}$ $L_i = 0.4 \text{ mH}$; $C_i = 5 \text{ nF}$</p> <p>1153651 (No. LR104225), Class 2258 02 and Class 2258 03</p>	
<p>Communication</p> <p>Load when connecting a</p> <ul style="list-style-type: none"> ● HART Communicators ● HART-Modems 	<p>230 to 1100 Ohm 230 to 500 Ohm</p>	
<p>Twinaxial cable</p> <p>Protocol</p> <p>PC/Laptop requirements</p> <p>Software for PC/Laptop</p>	<p>2-wire shielded: $\leq 3.0 \text{ km}$ (9800 ft); multi-wire shielded: $\leq 1.5 \text{ km}$ (4900 ft); see Section 9.5</p> <p>HART, Version 5.x</p> <p>IBM-compatible, RAM > 32 Mbytes, Hard disk > 70 Mbytes, RS 232 interface, VGA graphics</p> <p>WINDOWS 95 / 98 / NT 4.0 and SIMATIC PDM</p>	

TABLE 9-16 Specifications, Absolute Pressure and Filling Level Models

Device type:	Absolute pressure		Filling level
	Pressure series 7MF4233	Diff. pressure series 7MF4333	7MF4633 / 7MF4912
Application range	See Table 9-17	See Table 9-20	See Table 9-21
Function	Piezoresistive		
Measurement principle	Piezoresistive		
Input	Absolute pressure		Filling level
Measurement variable	Absolute pressure		Filling level
Measurement range	0.12 to 435 psia (4 ranges)		2.9 to 72 psia (4 ranges)
<ul style="list-style-type: none"> Span (continuously adjustable) <ul style="list-style-type: none"> Nominal pressure (PN) 470 psi Nominal pressure (PN) 2325 psi Nominal pressure (PN) 6174 psi 	0.12 to 435 psia (4 ranges)	0.12 to 2325 psia (5 ranges)	2.9 to 72 psia (4 ranges)
<ul style="list-style-type: none"> Lower measurement limit <ul style="list-style-type: none"> - Measuring cell with silicone oil filling - Measuring cell with inert filling liquid for process temp. $-20\text{ }^{\circ}\text{C} < \vartheta < 60\text{ }^{\circ}\text{C}$ for process temp. $+60\text{ }^{\circ}\text{C} < \vartheta < 100\text{ }^{\circ}\text{C}$ (max. $+85\text{ }^{\circ}\text{C}$ for 485 psi meas. cell) 	0 psi (absolute)		-100% of max span or 0.43 psi (abs) depending on remote seal
<ul style="list-style-type: none"> Upper measurement limit 	+100% of maximum span; maximum 2325 psi in oxygen measurement and inert filling liquid 2325 psi		+100% of max span
<ul style="list-style-type: none"> Start of scale (continuously adjustable) 	Between the measuring limits		
Output	4 to 20 mA		
Output signal	3.55 mA, factory set to 3.84 mA		
<ul style="list-style-type: none"> Lower limit (continuously adjustable) Upper limit (continuously adjustable) 	23.0 mA, factory set to 20.5 mA or optionally 22.0 mA		
<ul style="list-style-type: none"> Ripple (without HART communication) 	$I_{pp} \leq 0.5\%$ of maximum output current		
<ul style="list-style-type: none"> Electric damping <ul style="list-style-type: none"> - adjustable time constants (T_{66}) 	0 to 100 seconds in steps of 0.1 seconds, factory set to 0.1 seconds		
<ul style="list-style-type: none"> Current transmitter 	Adjustable 3.55 to 23 mA		
<ul style="list-style-type: none"> Failure signal 	Adjustable 3.55 to 23 mA		
Load	$R_B \leq (U_H - 10.5V) / 0.023A$ in Ω , U_H : power supply in V $R_B = 230$ to 500Ω (HART-Communicator) or $R_B = 1100\Omega$ (HART-Communicator)		
<ul style="list-style-type: none"> without HART communication with HART communication 	$R_B \leq (U_H - 10.5V) / 0.023A$ in Ω , U_H : power supply in V $R_B = 230$ to 500Ω (HART-Communicator) or $R_B = 1100\Omega$ (HART-Communicator)		
Characteristic	Forward acting or reverse acting		
Measuring accuracy	Forward acting, zero based, process diaphragm stainless steel; For flange level flush mount, silicone oil filling and room temperature $25\text{ }^{\circ}\text{C}$		
Reference conditions	$r = \text{maximum span} / \text{set span} = \text{span ratio}$		
Measurement error (limit point setting, including hysteresis and repetitive accuracy)			
<ul style="list-style-type: none"> linear characteristic <ul style="list-style-type: none"> $r \leq 10$ $10 < r \leq 30$ $30 < r \leq 100$ 	$\leq 0.1\%$	$\leq 0.15\%$	$\leq 0.15\%$
	$\leq 0.2\%$	$\leq 0.3\%$	$\leq 0.3\%$
		$\leq (0.0075 \cdot r + 0.075)\%$	$\leq (0.0075 \cdot r + 0.075)\%$
<ul style="list-style-type: none"> Repetitive accuracy Hysteresis 	Contained in measuring error		
Transient time (T_{63} , without electrical damping)	About 0.2 seconds		
Long-term drift over 12 months	$\leq (0.2 \cdot r)\%$		$\leq (0.1 \cdot r)\%$

	Absolute pressure		Filling level
	Pressure series 7MF4233	Diff. pressure series 7MF4333	7MF4633 / 7MF4912
Influence of ambient temperature • at -10 to +60 °C 100 inH ₂ O measuring cell 241 inH ₂ O measuring cell 646 and 2011 inH ₂ O measuring cell • at -40 to -10 °C and +60 to +85 °C 104 inH ₂ O measuring cell 241 inH ₂ O measuring cell 646 and 2011 inH ₂ O measuring cell	$\leq (0.1 \cdot r + 0.2) \% ^1$ $\leq (0.1 \cdot r + 0.15) \% / 10 K ^1$		$\leq (0.5 \cdot r + 0.2 ^2) \%$ $\leq (0.3 \cdot r + 0.2 ^2) \%$ $\leq (0.25 \cdot r + 0.2 ^2) \%$ 2) 0.4 inst. of 0.2 at $10 < r \leq 30$ $\leq (0.25 \cdot r + 0.15 ^3) \% / 10 K$ $\leq (0.15 \cdot r + 0.15 ^3) \% / 10 K$ $\leq (0.12 \cdot r + 0.15 ^3) \% / 10 K$ 3) 0.3 inst. of 0.15 at $10 < r \leq 30$
Influence of static pressure • on start of scale 100 inH ₂ O measuring cell 241 inH ₂ O measuring cell 646 and 2011 inH ₂ O measuring cell • on the span 8 inH ₂ O measuring cell			(0.3 · r) % per nom. pressure (0.15 · r) % per nom. pressure (0.1 · r) % per nom. pressure (0.1 · r) % per nom. pressure
Influence of installation position	≤ 0.02 inH ₂ O per 10° angle	≤ 0.28 inH ₂ O per 10° angle	Depends on the filling liquid in the mounting flange
Influence of power supply	0.005 % per 1 V change in voltage		
Operating conditions Installation conditions • Installation note	Process connection vertically downwards	Any	Determined by flange
Ambient conditions • Ambient temperature (in hazardous zones, note temperature class) Measuring cell - Measuring cell with silicone oil fill - Measuring cell with inert filling liquid Digital display • Ambient temperature limit • Storage temperature • Climate class, condensation • Degree of protection (EN 60 529) • EMC - Spurious emission - Interference resistance	-40 to $+85$ °C (-40 to $+85$ °F) -20 to $+85$ °C (-4 to $+185$ °F) -50 to $+85$ °C (-58 to $+185$ °F) see ambient temperature -30 to $+85$ °C (-22 to $+185$ °F) Permissible IP 65 EN 50 081-1 EN 50 082-2 and NAMUR NE 21		
Process conditions • Process temperature - Measuring cell with silicone oil fill - Measuring cell with inert filling liquid Span 435 psi at PN 6174 psi • Process temperature limit • Process pressure limit	-40 to $+100$ °C (-40 to $+212$ °F) -20 to $+100$ °C (-4 to $+212$ °F) -20 to $+85$ °C (-4 to $+212$ °F) see process temperature see Table 9-12 see Table 9-13 Nominal pressure (PN); see Table 9-14		
Constructional design Weight (without options) Transmitter with mounting flange without tube	about 3.3 lbs (1.5 kg)	about 9.9 lbs (4.5 kg)	DIN: about 24.3 to 28.7 lbs (11

Device type:	Absolute pressure		Filling level
	Pressure series 7MF4233	Diff. pressure series 7MF4333	7MF4633 / 7MF4912
			to 13 kg) ANSI: about 24.3 to 39.7 lbs (11 to 18 kg)
Dimensions	see Figure 9-1	see Figure 9-2	see Figure 9-4
Material			
<ul style="list-style-type: none"> • Material of wetted parts - Connection shank - Oval flange - Process diaphragm - Process flanges and sealing screw - O-ring 	Stainless steel W.-No. 1.4401 or Hastelloy C4, W.-No. 2.4610 Stainless steel, W.-No. 1.4401	Stainless steel, W.-No. 1.4404 or Hastelloy C276, W.- No. 2.4819 Monel, W.-No. 2.4360 Tantalum or gold	
		Stainless Steel, W.-No. 1.4408 Hastelloy C4, W.-No. 2.4610 or Monel, W.-No. 2.4360	
		FPM (Viton) or optionally: PTFE, FEP, FFPM and NBR	
Process material (O-ring) for mounting flange in the process flanges for standard applications for vacuum applications			FPM (Viton) Copper
<ul style="list-style-type: none"> - High pressure side Process diaphragm at mtg. Flange 			Stainless steel, W.-No. 1.4571, Monel 400 W.-No. 2.4360, Hastelloy B2 W.-No. 2.4617, Hastelloy C276, W.-No. 2.4819, Hastelloy C4, W.-No. 2.4610, Tantalum, PTFE, ECTFE
Processing face			Smooth DIN 2526, Form D or ANSI B16.5 RF for stainless steel M.-No. 1.4571, DIN 2526 Form E or ANSI B16.5 RSFS for other materials.
<ul style="list-style-type: none"> - Low pressure side Process diaphragm Process flanges and sealing screw Connection shank O-ring 			Stainless steel W.- No 1.4404 Stainless steel W.- No 1.4408 Stainless steel W.- No 1.4401 FPM (Viton)
<ul style="list-style-type: none"> • Material of non-wetted parts - Electronics housing - Process flange screws - Mounting bracket (optional) 	Low copper diecast aluminum GD-ALSi 12, polyester-based varnish or stainless steel precision casting, stainless steel rating plate Steel, galvanized and yellow-chromed or stainless steel	Steel, galvanized, yellow-chromed or stainless steel	
Measuring cell filling	Silicone oil filling or inert liquid (maximum pressure 2325 psi for oxygen measurement)		Silicone oil
Filling liquid mounting flange			Silicone oil or other version
Process connection	Connection shank G ¹ / ₂ A DIN 16 288, female thread ½-14NPT or oval flange	Female thread 1/4 - 18 NPT and Flange connection DIN 19213 with mounting thread	

Device type:	Absolute pressure		Filling level
	Pressure series 7MF4233	Diff. pressure series 7MF4333	7MF4633 / 7MF4912
	maximum range 2325 inH ₂ O with mounting thread M10 / M12 or 7/16-20 UNF	M10 or 7/16 - 20 UNF	
High pressure side Low pressure side			DIN and ANSI flange Female thread 1/4 - 18 NPT and Flange connection DIN 19213 with mounting thread M10 or 7/16 - 20 UNF
Electrical connection	Screw terminals, cable inlet or screwed gland Pg 13.5 (adapter), M20 x 1.5 or 1/2 - 14 NPT, or Han 7D/Han 8U plug		
Display and user interface Input keys Digital display	3 pushbuttons for local programming at the device Installed, cover with window (optional)		
Power supply (U_H) Terminal voltage at the transmitter Ripple Noise	DC 10.5V to 45V or DC 10.5V to 30V in intrinsically safe operation U _{pp} ≤ 0.2V (47 to 125 Hz) U _{eff} ≤ 1.2 mV (0.5 to 10 kHz)		
Certificates and licenses CENELEC • Intrinsic safety - EC test certificate - Maximum ambient temperature - Connection to certified intrinsically safe circuits with the maximum values - Active internal inductance - Active internal capacitance • Explosion proof - Certificate of conformity - Maximum ambient temperature • Ex-tested zone 2n - Registration number FMRC (Factory Mutual Research Corp.) • Intrinsic safety and explosion proof • Explosion proof • Dust-ignition proof • Intrinsically safe • Entity parameters CSA (Certificate of Compliance)	The specifications in the official EC test certificate and the applicable supplements are exclusively valid DIN EN 50 014: 1997, EN 50 020: 1994 and EN 50 284: 1999 Ex II 1/2 G EEx ia IIC T4 / T5 / T6 TÜV 99 ATEX 1494 +85 °C temperature class T4, +70 °C temperature class T5, +60 °C temperature class T6 U _i = 30 V, I _i = 100 mA, P _i = 750 mW R _i = 300Ω L _i = 1 mH C _i = 6 nF available available consult factory consult factory consult factory 3008490 (3610, 3615) For class I, division 1, groups A, B, C, and D For class II, division 1, groups E, F, and G, indoor and outdoor (NEMA 4X) hazardous (classified) locations With entity, for use in class I, division 1, groups A, B, C, D, E, F, and G, indoor and outdoor (NEMA 4X) hazardous (classified) locations V _{max} = 30V; I _{max} = 100 mA; L _i = 0.4 mH; C _i = 5 nF 1153651 (LR104225), Class 2258 02 and Class 2258 03		
Communication Load when connecting a: • HART Communicator • HART Modem Twinaxial cable Protocol PC/Laptop requirements Software for PC/Laptop	230 to 1100 Ohm 230 to 500 Ohm 2-wire shielded: ≤ 3.0 km (9800 ft); multi-wire shielded: ≤ 1.5 km (4900 ft); see Section 9.5 HART, Version 5.x IBM-compatible, RAM > 32 Mbytes, Hard disk > 70 Mbytes, RS 232 interface, VGA graphics WINDOWS 95 / 98 / NT 4.0 and SIMATIC PDM		

9.4 MEASURING SPANS AND OVERLOAD LIMITS

This section provides tables that contain the measuring spans and overload limits for each series DSIII transmitter.

TABLE 9-17 Pressure Transmitter, 7MF4033

Measuring Span, Continuously Adjustable			Process Pressure Limits	
			Lower	Upper
0.15	To	14.5 psi	-14.5 psi	87 psi
0.58	To	60 psi	-14.5 psi	145 psi
2.3	To	230 psi	-14.5 psi	464 psi
9.1	To	925 psi	-14.5 psi	1450 psi
23	To	2325 psi	-14.5 psi	3625 psi ¹⁾
58	To	5800 psi ¹⁾	-14.5 psi	8700 psi ¹⁾

1) For oxygen measurement, maximum is 2325 psi.

TABLE 9-18 Differential Pressure and Flow Transmitters, 7MF4433 & 7MF4533

Measuring Span, Continuously Adjustable			Maximum Working Pressure	
			7MF4433	7MF4533
0.4	To	8 inH ₂ O	470 psi ⁴⁾	470 psi ⁴⁾
0.4	To	24 inH ₂ O	2300 psi	2300 psi
1	To	100 inH ₂ O	2300 psi	6090 psi
2.4	To	240 inH ₂ O	2300 psi	6090 psi
6.4	To	640 inH ₂ O	2300 psi	6090 psi
4.3	To	435 psi	2300 psi	6090 psi ^{1), 2), 3)}

1) For oxygen measurement, maximum is 2325 psi

2) Silicon measuring cell fill only

3) MWP 4568 psi with stainless steel process flange screw

4) Not suitable for remote process mounting

TABLE 9-19 Absolute Pressure, Gauge Construction, 7MF4233

Measuring Span, Continuously Adjustable			Process Pressure Limit
3.3	To	100 inH ₂ O see Note	87 psi
18	To	525 inH ₂ O	145 psi
64	To	2000 inH ₂ O	435 psi
400	To	12,000 inH ₂ O	1450 psi

Note, 100 inH₂O Cell

This measuring cell is designed for operation within the measuring limits of 0 inH₂O (absolute) to 100 inH₂O (absolute). When stored in the normal ambient pressure of about of about 14.7 psi (absolute), the measuring cell is in the overload state. An overload error of up to 0.8 inH₂O may occur. The overload disappears in normal operation within the measuring limits and the transmitter operates within specifications.

When performing accurate continuous pressure measurements within the measuring limits, a readjustment of the transmitter zero for absolute pressure must be performed after approximately one day (refer to Section 6.2.5).

If pressure measurements exceed the measuring limits repeatedly (e.g. batch processes with transitions between vacuum and ventilation), a measuring cell with a maximum range of 525 inH₂O should be selected to avoid overloading.

TABLE 9-20 Absolute Pressure, Differential Construction, 7MF4333

Measuring Span, Continuously Adjustable			Process Pressure Limits
3.3	To	100 inH ₂ O see Note	464 psi
18	To	525 inH ₂ O	464 psi
64	To	2000 inH ₂ O	464 psi
400	To	12,000 inH ₂ O	2320 psi
77	To	2325 psi	3625 psi

* 2325 psi at M10 process connection.

Note, 100 inH₂O Cell

This measuring cell is designed for operation within the measuring limits of 0 inH₂O (absolute) to 100 inH₂O (absolute). When stored in the normal ambient pressure of about of about 14.7 psi (absolute), the measuring cell is in the overload state. An overload error of up to 0.8 inH₂O may occur. The overload disappears in normal operation within the measuring limits and the transmitter operates within specifications.

When performing accurate continuous pressure measurements within the measuring limits, a readjustment of the transmitter zero for absolute pressure must be performed after approximately one day (refer to Section 6.2.5).

If pressure measurements exceed the measuring limits repeatedly (e.g. batch processes with transitions between vacuum and ventilation), a measuring cell with a maximum range of 525 inH₂O should be selected to avoid overloading.

TABLE 9-21 Flanged Level, 7MF4633 / 7MF4912

Measuring Span, Continuously Adjustable			Maximum Working Pressure
10	To	100 inH ₂ O	consult factory
10	To	240 inH ₂ O	consult factory
20	To	640 inH ₂ O	consult factory
64	To	2000 inH ₂ O	consult factory

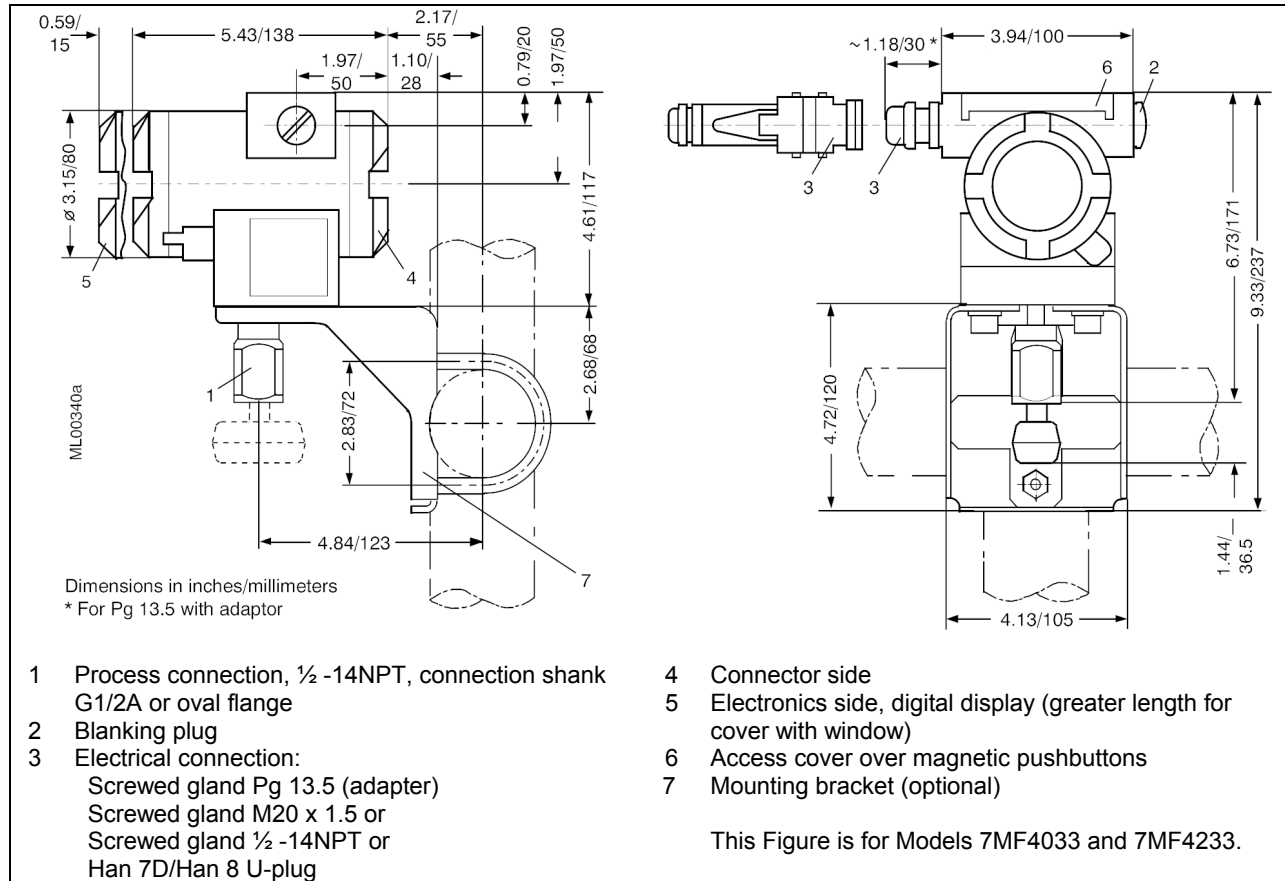

FIGURE 9-1 Dimensions, Gauge Construction, Pressure and Absolute Models

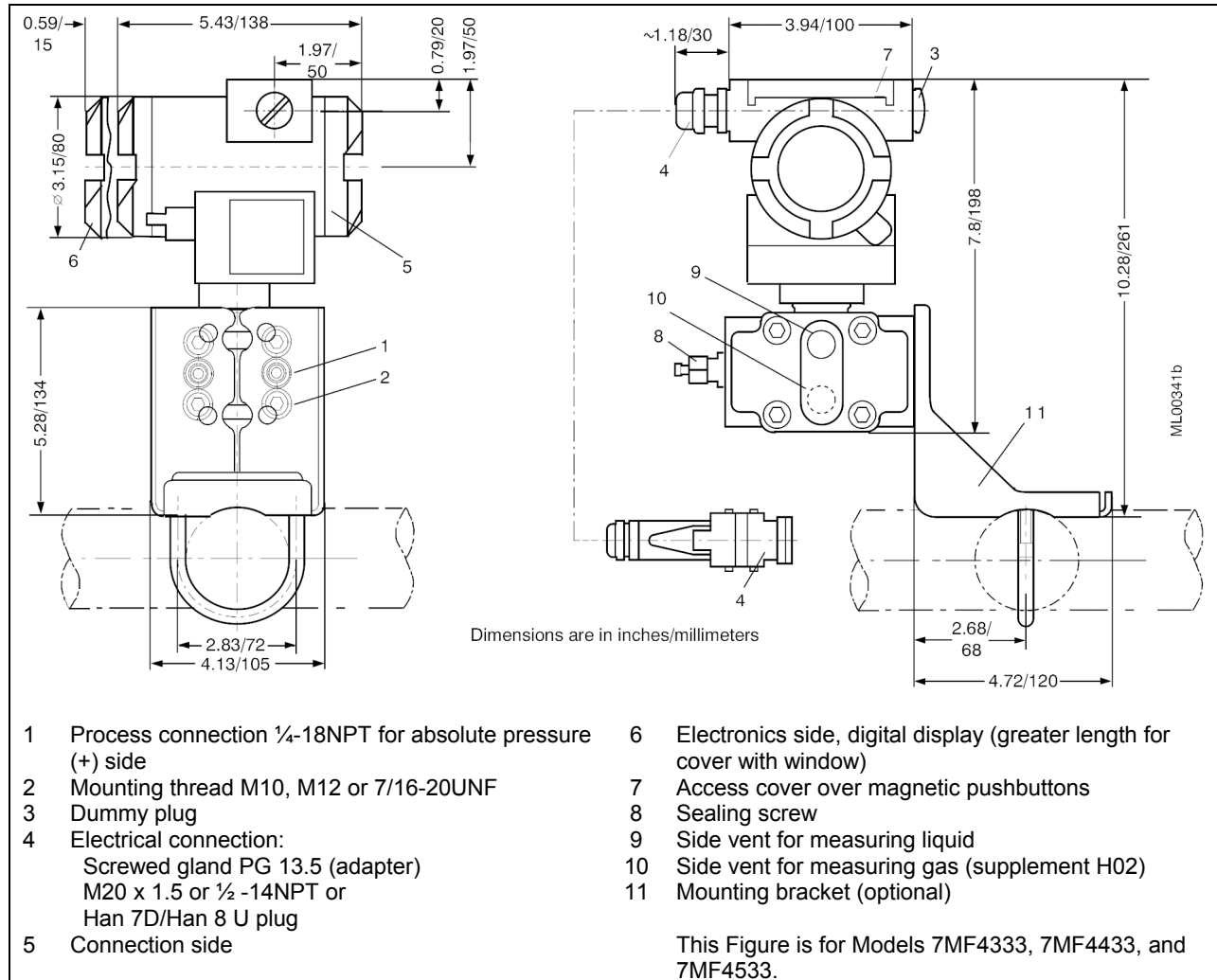

FIGURE 9-2 Dimensions, Differential Construction, Diff., Flow and Absolute Models

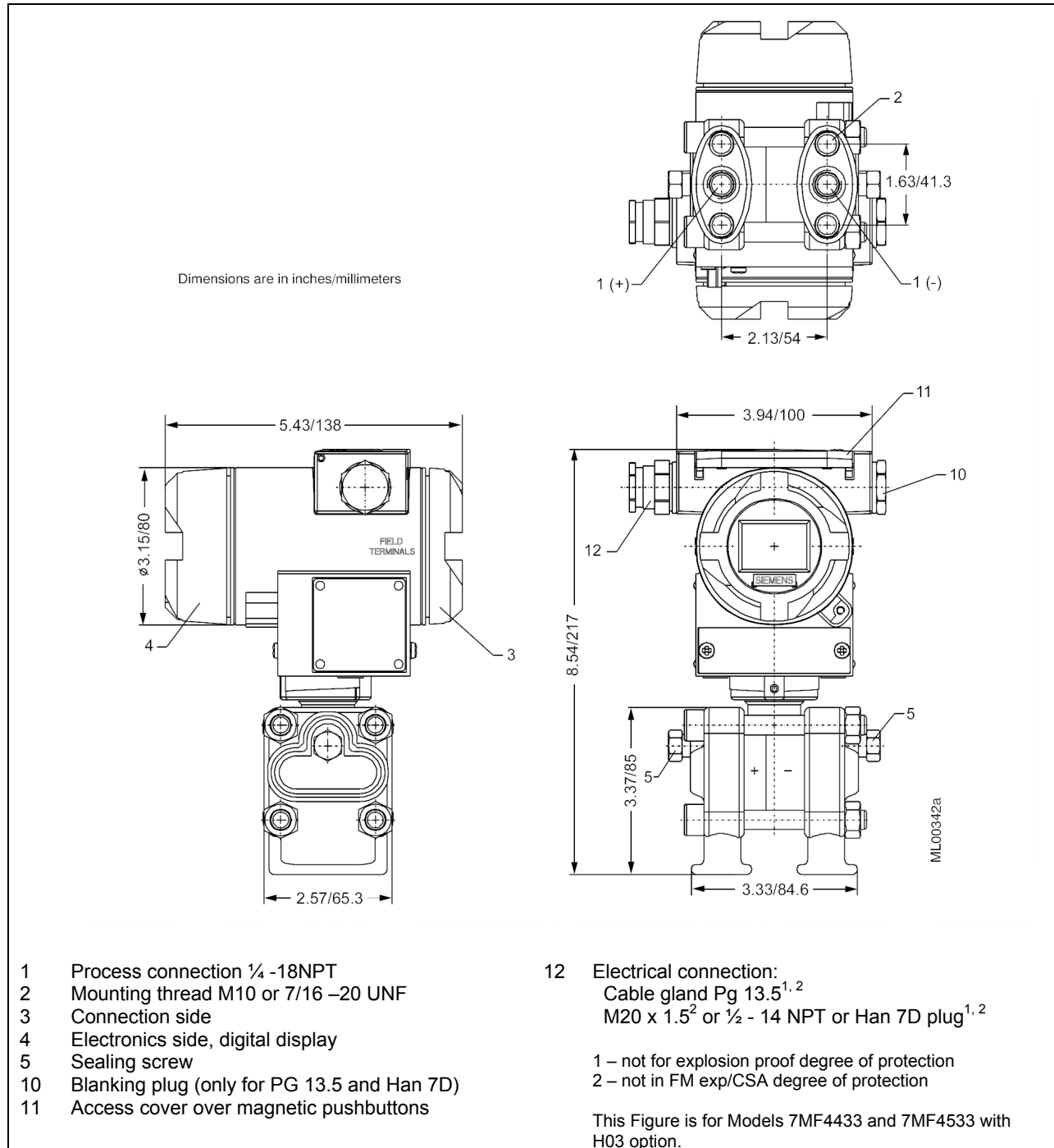

FIGURE 9-3 Dimensions, Differential Pressure and Flow Models with H03 Option

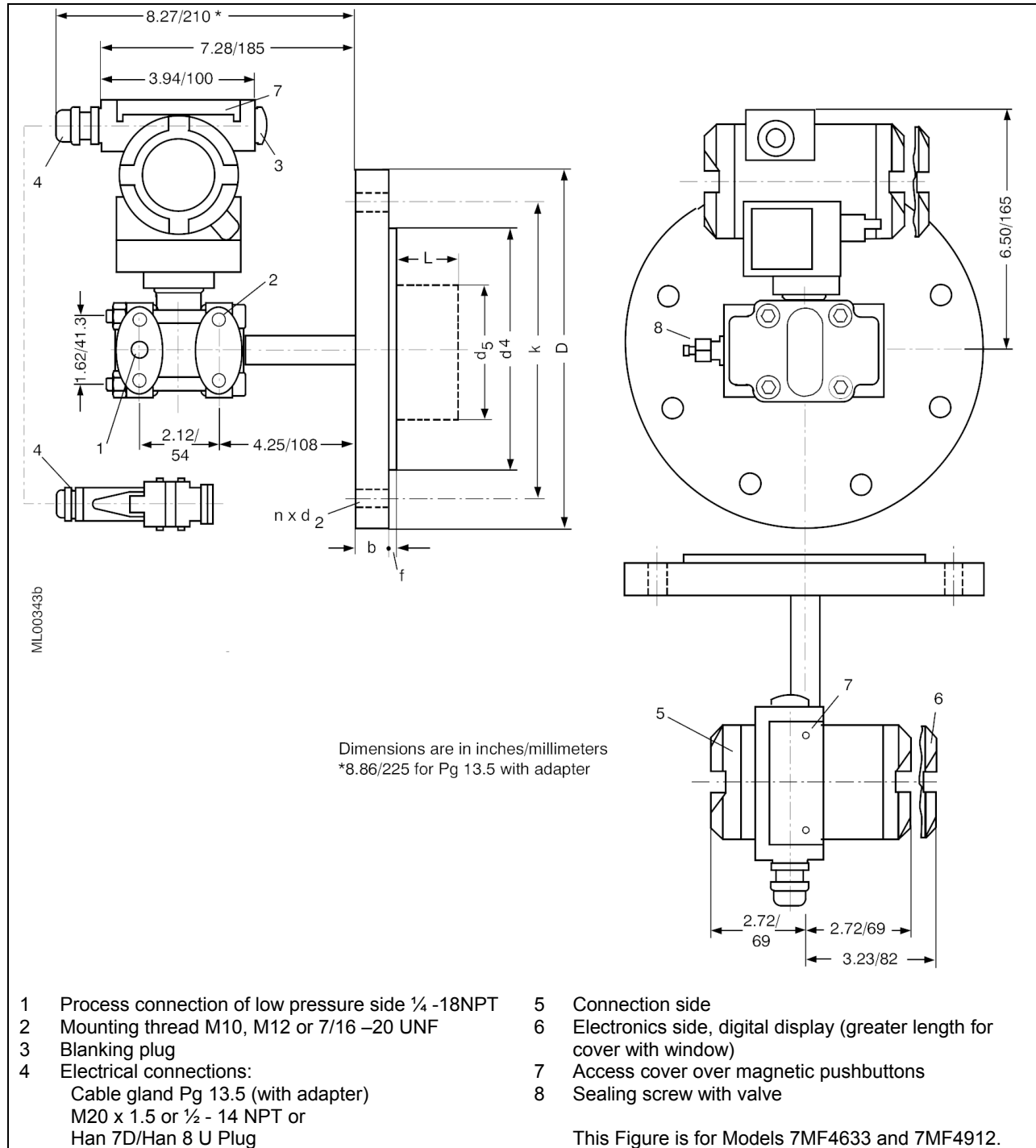

FIGURE 9-4 Dimensions, Flanged Level Models

9.5 NETWORK TOPOLOGY

Point-to-Point

Transmitter Quantity	1
Network Signal and Connection	Analog 4-20 mA, single current loop, see Figures 4-6, 4-7, and 4-8
Network Resistance	See Section 4.3.5

Multi-Drop

Transmitter Quantity	1-15
Network Signal and Connection	Digital, parallel connected, see Figure 4-9
Network Resistance	See Section 4.3.5

9.5.1 Two-Wire Cable

Type	Twisted single-pair, shielded, copper
Conductor Size for Network Length	
Less than 5000 feet (1524 m)	24 AWG (0.23 mm ²) minimum
More than 5000 feet (1524 m)	20 AWG (0.56 mm ²) minimum, 16 AWG (1.3 mm ²) maximum
Cable Capacitance	Refer to Section 4.3.6
Recommendation	Belden 8641, 24 AWG (0.23 mm ²) Belden 8762, 20 AWG (0.56 mm ²)
Length, Maximum	Refer to Section 4.3.6

9.6 HAZARDOUS AREA CLASSIFICATIONS

Tables 9-8 and 9-9 list the hazardous area classifications available at the time this manual was printed. Contact your local Siemens representative or the factory for the latest classifications.

CE Approval - A Declaration of Conformity can be found on a later page in this section.

Intrinsically Safe Operation in a Hazardous Area

Operation is permitted only with circuits that are certified as intrinsically safe. The transmitter complies with Category 1/2 and it may be installed in zone 0.

The EU type examination certificate applies to installation on the walls of containers and pipes that may contain explosive gas/air or vapor/air mixtures only under atmospheric conditions (pressure: 12 psi to 16 psi, temperature: -20°C to +60°C (-4°F to +140°F)). The permissible ambient temperature range is -40°C to +85°C (-40°F to +185°F), in explosion hazard areas (for T4) -40°C to +85°C (-40°F to +185°F).

The user may also apply the device in non-atmospheric conditions outside the limits set in the EC-Type Examination Certificate, according to the conditions for use (explosive mixture) and if the required additional security measures have been met. The limit values stated earlier in this section must be observed in any case.

Installation in Zone 0

The installation must be adequately sealed (IP67 to EN 60 529). An industry standard (e.g. DIN, NPT) threaded joint is suitable, for example.

When operating with intrinsically safe power supply units of the “ia” category, the explosion protection does not depend on the chemical resistance of the seal diaphragm.

When operating with intrinsically safe power supply units of the “ib” category or for units with explosion proof protection “Ex d” and simultaneous use in zone 0, the explosion protection of the transmitter depends on chemical resistance of the diaphragm. Under these operating conditions, the transmitter may be used only for those inflammable gases and liquids to which the diaphragms are adequately chemically resistant to avoid corrosion.

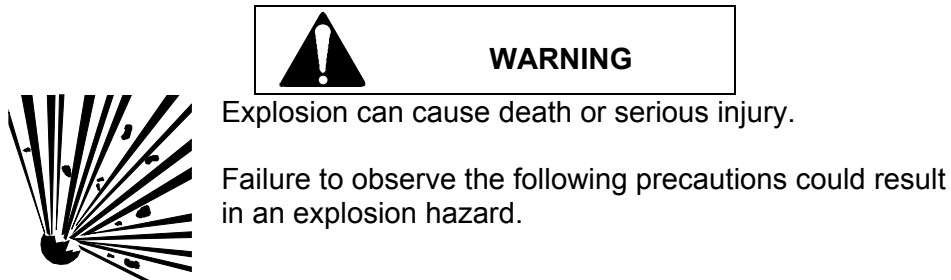

Comply with the specifications of the examination certificate valid in your country.

Comply with your country's laws and regulations that apply to electrical installation in an explosive environment.

Be sure that the available power supply complies with the specifications on the transmitter rating plate and statements in the examination certificate in your country. Dust-proof protection caps in the cable inlets must be replaced by suitable screw-type gland or dummy plugs that must be appropriately certified for transmitters with explosion proof type of protection.

9.6.1 CSA Hazardous Locations Precautions

This section provides CSA hazardous location precautions that should be observed by the user when installing or servicing the equipment described in this manual. These statements supplement those given in the preceding section.

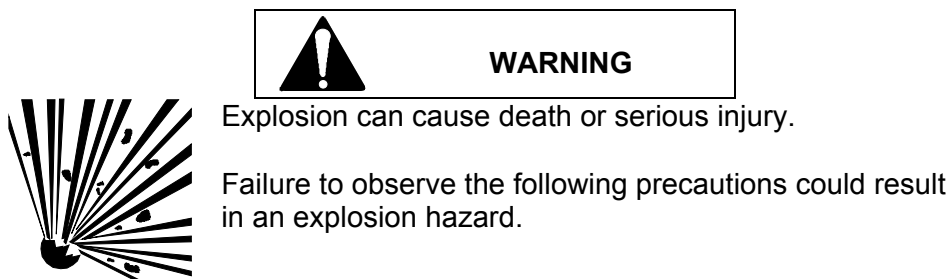

Precautions - English

For Class I, Division 1 and Class I, Division 2 hazardous locations:

- Use only factory-authorized replacement parts. Substitution of components can impair the suitability of this equipment for hazardous locations.

For Division 2 hazardous locations:

When the equipment described in this Instruction is installed without safety barriers, the following precautions should be observed. Switch off electrical power at its source (in non-hazardous location) before connecting or disconnecting power, signal, or other wiring.

Précautions - Français

Emplacements dangereux de classe I, division 1 et classe I, division 2:

- Les pièces de rechange doivent être autorisées par l'usine. Les substitutions peuvent rendre cet appareil impropre à l'utilisation dans les emplacements dangereux.

Emplacement dangereux de division 2:

Lorsque l'appareil décrit dans la notice ci-jointe est installé sans barrières de sécurité, on doit couper l'alimentation électrique à la source (hors de l'emplacement dangereux) avant d'effectuer les opérations suivantes branchement ou débranchement d'un circuit de puissance, de signalisation ou autre.

SIEMENS

**EG-Konformitätserklärung
EC Declaration of Conformity**

No. 880.00 – 12/99

Hersteller: Siemens AG.....
 Manufacturer:
 Anschrift: Östliche Rheinbrückenstr. 50; 76187 Karlsruhe.....
 Address: Bundesrepublik Deutschland.....
 Produkt- bezeichnung: SITRANS P DSIII
 Product description: 7MF4&33-xxxxx-xxxx-Z mit &=0,2,3,4,5,6.....
 Product description:

Das bezeichnete Produkt stimmt in der von uns in Verkehr gebrachten Ausführung mit den Vorschriften folgender Europäischer Richtlinien überein:

The product described above in the form as delivered is in conformity with the provisions of the following European Directives:

89/336/EWG Richtlinie des Rates zur Angleichung der Rechtsvorschriften der Mitgliedstaaten über die elektromagnetische Verträglichkeit (geändert durch 91/263/EWG, 92/31/EWG, 93/68/EWG und 93/97/EWG).

Council Directive on the approximation of the laws of the Member States relating to electromagnetic compatibility (amended by 91/263/EEC, 92/31/EEC, 93/68/EEC and 93/97/EEC)

CE-Kennzeichnung / CE marking : 12/99

Die Konformität mit den Richtlinien wird nachgewiesen durch die Einhaltung folgender Normen:
Conformity to the Directives is assured through the application of the following standards:

Referenznummer Reference number	Ausgabedatum Edition	Referenznummer Reference number	Ausgabedatum Edition
EN 50081-1.....	März `93.....
EN 50082-2.....	März `95.....

Karlsruhe....., den / the 17.12.1999.....

Siemens AG

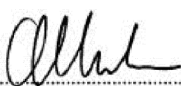
Muhr, Entwicklung..... 

Name, Funktion
Name, function

Unterschrift
signature

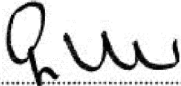
Gittler, Fertigung..... 

Name, Funktion
Name, function

Unterschrift
signature

Diese Erklärung bescheinigt die Übereinstimmung mit den genannten Richtlinien, ist jedoch keine Zusicherung von Eigenschaften. Die Sicherheitshinweise der mitgelieferten Produktdokumentation sind zu beachten.
This declaration certifies the conformity to the specified directives but contains no assurance of properties. The safety documentation accompanying the product shall be considered in detail.

FIGURE 9-5 Declaration of Conformity

CERTIFICATE OF NACE COMPLIANCE

Siemens Energy & Automation, Inc.
1201 Sumneytown Pike
Spring House, PA 19477

certifies under its sole responsibility that a SITRANS DSIII Pressure Transmitter with one of the following factory configured options

Wetted Parts Materials Code B (Hastelloy diaphragm with 316 stainless steel flanges)
DP Non-Wetted Materials Code 2 (stainless steel bolts with aluminum housing)
DP Non-Wetted Materials Code 3 (stainless steel bolts and housing)
Gauge Non-Wetted Materials Code 0 or 3 (aluminum or stainless steel housing)

is in compliance with NACE MR0175-96.



March 16, 2001

Christopher J. O'Brien
Director of Process Instrumentation
Siemens Energy & Automation
Process Industries Division
Spring House, PA 19477

FIGURE 9-6 Certificate of NACE Compliance

10.0 GLOSSARY

Defined below are terms relevant to the SITRANS P DSIII transmitter, this User's Manual, pressure measurement technology, and HART networks.

Absolute (abs) Pressure – A pressure measured against absolute zero or a total vacuum as a reference. The units of measurement are called absolute pressure units. For example: psia = pounds per square inch absolute.

Adjust - Zero and full scale are adjusted using a single reference pressure. See Set.

Analog Signaling – A low-current signal of 4 to 20 mA_{dc} from a field instrument to a primary master or non-signaling hardware.

ANSI – American National Standards Institute

Application Point or Switch Point - The point at which the output current characteristic changes from linear to square root when a square root output characteristic is selected (Modes 11 and 12).

AWG – American Wire Gauge

Barrier – A device designed to limit the voltage and current in a hazardous area even if certain types of faults occur on the non-hazardous side of the barrier.

Barrier Resistance – The maximum end-to-end resistance of a barrier, as specified by the barrier manufacturer. If both supply and return barriers are used in a network, the barrier resistance is the sum of the end-to-end resistance of both barriers. For active barriers that use resistance to limit current, the barrier resistance is the internal resistance between the hazardous area terminal and the barrier internal node where voltage is regulated.

Blind - No reference pressure is applied.

Commissioning – Testing of a transmitter and associated loop to verify transmitter configuration and loop operation (piping, valving, wiring, control algorithm, data logging, etc.).

Configuration – A database (or archive) created using a HART Communicator and downloaded to a transmitter to define transmitter operation.

Configure/Configuring – The entering of specific parameter data into a HART Communicator to be downloaded to a transmitter to define that transmitter's operating characteristics.

Current Sense Resistor – The resistor in a network across which the field instrument (transmitter) signal voltages are developed.

Damping – A user-selectable output characteristic that increases the response time of a transmitter to smooth the output when the input signal contains rapid variations.

Digital Signaling – The high frequency HART signal.

Explosion-Proof Enclosure – An enclosure that can withstand the explosion of gases within it and prevent the explosion of gases surrounding it due to sparks, flashes, or the explosion of the container itself, and maintain an external temperature that will not ignite the surrounding gases.

Field Instrument – A network element that uses current variation for digital signaling or digital plus analog signaling.

Gauge Pressure – A pressure measured against atmospheric or barometric pressure as a reference. The units of measurement are called gauge pressure units. For example: psig = pounds per square inch gauge.

HART – Highway Addressable Remote Transducer – A communication protocol that provides simultaneous analog and digital signaling between master and slave devices. It is supported by the HART Communications Foundation.

HART Network – A single pair of cabled wires and the attached communicating HART elements.

Intrinsically Safe Instrument – An instrument that will not produce any spark or thermal effects under normal or abnormal conditions that will ignite a specified gas mixture.

Keyboard or Magnetic Pushbuttons - Three pushbuttons or keys, located under a cover on the electrical entrance portion of the transmitter enclosure and used for local configuration of the transmitter.

Leporello - The condensed transmitter user's manual found inside the field terminals enclosure cap. A book that unfolds in accordion fashion.

Lower Range Limit (LRL) – The lowest value of the measured variable that a transmitter or other measurement device can be configured to measure.

Lower Range Value (LRV) – Representing the 4 mA point in the transmitter's output, the LRV is the lowest value of the measured value that the transmitter can be configured to measure.

MA or p_{min} - Minimum operating input pressure.

Magnetic Pushbuttons - See Keyboard.

Maximum Overrange – The maximum pressure (static + differential) that can be applied safely to a transmitter.

ME or p_{max} - Maximum operating input pressure.

Measuring Cell - Sensor.

Multi-Drop Network – A HART network having from 1 to 15 field instruments that are parallel connected on a single 2-wire cable. This network uses digital signaling only.

Network – A network includes the following items:

- Transmitter(s)
- Network element (controller, recorder, passive non-signaling element, or other device)
- Cabling interconnecting these devices

- Barriers for intrinsic safety, if installed
- Current sense resistor

Network Element – Any field instrument or primary or secondary master.

Network Resistance – The sum of the current sense resistance, barrier resistance, if any, and any other resistance on the network.

NPT – National Pipe Thread

Point-To-Point Network – A network having a single field instrument and primary master. Analog signaling or analog plus digital signaling is possible.

Polling Address – A unique number assigned during configuration that identifies a transmitter connected to a network. An address between 1 and 15 assigned to a transmitter connected to a Multi-Drop network. A transmitter connected to a Point-to-Point network has 0 as an address.

Primary Master – The single controlling network element that communicates with one or more field instruments, such as a Model 353 Process Automation Controller.

Reranging – Changing a transmitter's 4 and 20 mA settings (i.e., setting LRV and URV); this is a configuration function.

Secondary Master – An occasional user of a network, such as the HART Communicator.

Sediment – Solid material that settles in a liquid or gas and can cause blockage that may affect pressure measurement.

Sensor - Measuring cell

Set - Zero and full scale are set using two reference pressures. See Adjust.

Span – Algebraic difference between the upper and lower range values (URV and LRV).

Switch Point - See Application Point.

Transducer – A device that accepts an input, such as pressure, and converts that input into an output of some other form, such as a voltage.

Upper Range Limit (URL) – The highest value of the measured variable that a transmitter can be configured to measure.

Upper Range Value (URV) – Representing the 20 mA point in a transmitter's output, this is the highest value of the measured variable that the transmitter is currently configured to measure.

■

A.0 APPENDIX A - ONLINE CONFIGURATION MAP

This Appendix contains a detailed configuration map showing the available online configuration options when using the Model 275 HART Communicator – see the Note below.

Note: The Configuration Map for the Model 375 Field Communicator is shown at the back of this manual. Be sure to read the manual supplied with the Model 375 before installing or using the device.

To use the map:

1. Connect the Model 275 HART Communicator to a powered SITRANS P DSIII transmitter. See Section 2 Model 275 HART Communicator and Section 4 Installation.
2. Press the Communicator's I/O key to turn it on. A Communicator self-test routine will be initiated and, upon successful completion, the Communicator will poll the connected transmitter(s).
3. When the Online menu appears, press 3 to access the Device Setup menu, if configuring or servicing the transmitter.

Note that 5 items appear in the Device Setup menu. The first three: 1 Process Variables, 2 Diagnostics/Service, and 3 Basic Setup are mapped in Figure A-1 Part 1. The last two: 4 Detailed Setup and 5 Review are mapped in Figure A-1 Part 2. The figures are on facing pages for ease of use.

1 Pressure +							
2 Type +							
3 Device setup	1 Process variables	1 Pressure +					
		2 % range +					
	3 Analog output +						
	4 Sensor temperature +						
	2 Diagnostics/service	1 Diagnosis	1 Min/max pointer	1 Pressure pointer		1 Pressure maximum	
						2 Pressure minimum	
						3 Reset pointer	
				2 El Temperature pointer		1 El Temperature max	
						2 El Temperature min	
						3 Reset pointer	
				3 Sensor Temperature pointer		1 Sensor Temperature max	
						2 Sensor Temperature min	
						3 Reset pointer	
			2 Operating hours		1 Operating hours E1		
					2 Operating hours S		
			3 Warnings/alarms		1 W/A time unit		
					2 Calibrate interval	1 Calibrate status	
						2 W/A acknowledge	
				3 Calibration timer >			
				4 Calibration warning			
				5 Calibration alarm			
				6 W/A activation			
			3 Service interval	1 Service status			
				2 W/A acknowledge			
			3 Service timer				
			4 Service warning				
			5 Service alarm				
			6 W/A activation				
		4 AO saturation	1 Saturation alarm				
			2 Alarm duration				
			3 Alarm activation				
		4 Status	1 Status summary				
			2 Hardware/Firmware status				
			3 Diagnostic alarm status				
			4 Diagnostic warning status				
			5 Simulation status				
2 Simulation/Test		1 Simulation	1 Loop Test				
			2 Inputs >				
		2 Test	1 Self Test				
			2 Master reset				
3 Control modes		1 Local keys control mode					
		2 Write protect (status)					
		3 Set write protect (enable)					
4 Trim		1 Position correction					
		2 Sensor trim	1 Sensor trim points				
			2 Zero trim				
			3 Lower sensor trim				
			4 Upper sensor trim				
		3 Trim analog output	1 D/A trim				
			2 Scaled D/A trim				
5 Restore manufacturer trims		1 All trims					
		2 DAC trims					
		3 Position correction					
		4 Sensor trim					
6 All measured values		1 Pressure +					
		2 Raw value					
		3 Sensor Temperature +					
		4 El Temperature +					
		5 AO +					
3 Basic setup	1 Tag						
	2 (Engineering) Units						
	3 Position correction						
	4 LRV						
	5 URV						
	6 Damping						
	7 Transfer function						
		Notes:	1. + = Active data displayed				
			2. HART Communicator, Rev 5; firmware Rev 2.2				
			3. > = To additional menu(s)				

Continued in
Figure A-1
Part 2
↓

FIGURE A-1 Online Configuration Map, Part 1 of 2

<p style="text-align: center;">↑</p> <p>3 Device setup, continued in Figure A-1, Part 1</p>	<p>4 Detailed setup See Note 4</p>	<p>1 Sensors</p>	1 Pressure sensor	1 Pressure +		
				2 (Engineering) Units		
			2 Temperature sensor	1 Sensor temperature +		
				2 EI temperature +		
			<p>2 Signal condition</p>	1 Process variables	1 Pressure +	
					2 % range +	
					3 AO +	
					4 Sensor Temperature +	
				2 Position correction		
				3 Zero/span set	1 Keypad input	1 LRV
				2 URV		
				3 Pressure (Eng.) Units		
				4 LSL		
				5 USL		
			2 Apply values			
			4 Damping			
			5 Transfer function			
			6 Measuring speed			
		<p>3 Output condition</p>	1 Analog output	1 AO +		
				2 Pressure		
				3 Alarms >		
				4 Lower AO limit		
				5 Upper AO limit		
			2 HART output	1 Poll address		
				2 Num request preambles		
		3 Num response preambles				
<p>4 Device information</p>	1 Ranges and limits	1 Module range				
		2 Pressure USL				
		3 Pressure LSL				
		4 Pressure minimum span				
	2 Common device information	1 Manufacturer				
		2 Model				
		3 Measurement type				
		4 Device order number				
		5 Explosion protection				
		6 Device ID				
		7 Pressure sensor S/N				
		8 Final assembly number				
		9 Electrical connector				
		Electrical housing material				
		Write protect				
		Tag				
		Date				
		Descriptor				
		Message				
	3 Sensor information	1 Process connection				
		2 Flange type				
		3 Flange material				
		4 Process flange bolt				
		5 Isolator material				
	6 Fill fluid					
	7 O-ring material					
	8 Drain & vent/plug material					
	9 Drain & vent/plug position					
4 Remote seal	1 RS type					
	2 RS isolator material					
	3 RS fill fluid					
	4 Number of remote seal					
	5 Extension length					
5 Local meter	1 Meter type					
	2 Unit tracking					
	3 Local display units					
	4 Bargraph					
6 Revision numbers	1 Universal rev.					
	2 Field device revision					
	3 Software revision					
	4 Hardware revision					
5 Reviews	Step through configuration					

FIGURE A-1 Online Configuration Map, Part 2 of 2



B.0 APPENDIX B - HAZARDOUS AREA INSTALLATION

This Appendix presents wiring and barrier selection information for installation of the transmitter in a hazardous location.

The installer should carefully select barriers based on the required protection, loop wiring, manufacturer's barrier performance data, and the data in the control drawings on the next two pages.

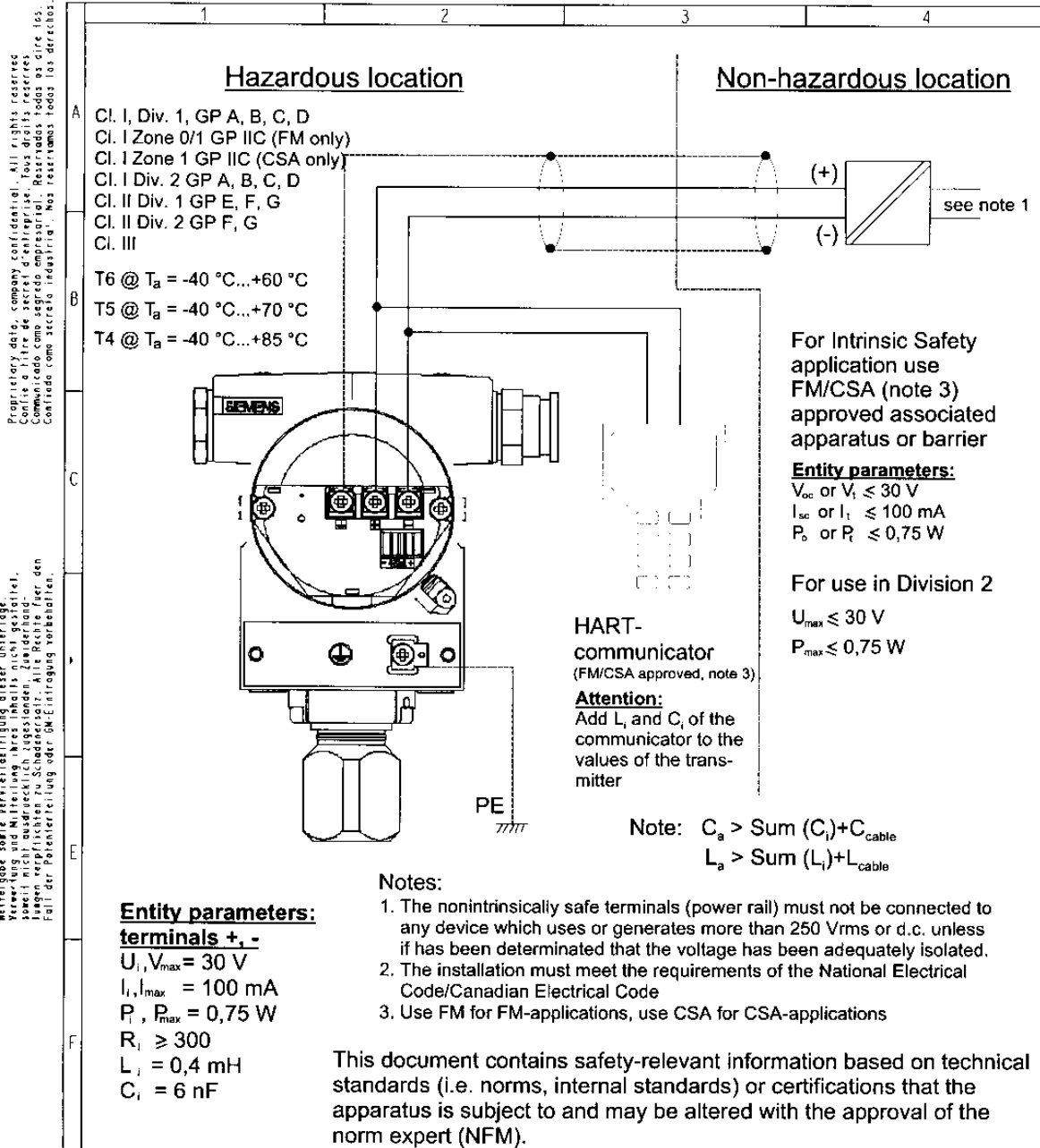

Proprietary data, company confidential. All rights reserved.
 Confidencial e de segredo empresarial. Reservados todos os direitos.
 Confiado como secreto industrial. Nos reservamos todos los derechos.

Weitergabe sowie Vervielfältigung dieser Unterlagen, insbesondere auszugsweise, ist ohne schriftliche Genehmigung der Siemens AG in Deutschland. Alle Rechte fuer den Fall der Patenterteilung oder GM-Eintragung vorbehalten.

Notizen:		Modelltyp:		Zeichnungsname: DSFMCSA5 ds4		FM-Id:	
833		Projektionsschema					
				engineering obligation for delivery			
06	79A15967	30.04.02	SM	Datum	30.05.00	transmitter SITRANS P MS/DSIII type 7MF4**3 control drawing (FM, CSA)	
05	79A15967	22.12.00	H.G.	Name	S. Mueller		
04	79A15967	12.12.00	SM	P-Dat			
03	79A15967	27.10.00	SM	Prüfer			
02	79A12942	24.08.00	SM				
ZS	Mitteilung	Datum	Name	Siemens AG A&D PA11		Blatt 1 von 1 Bl.	
						A5E00072770A	

Proprietary data, company confidential. All rights reserved.
 Confite o título de segredo empresarial. Todos direitos reservados.
 Comunicado como segredo empresarial. Reservados todos los derechos.
 Comunicado como segredo industrial. Reservados todos los derechos.

Weitergabe sowie Vervielfältigung dieser Unterlage,
 Vervielfachung und Mitteilung, ihres Inhalts nicht gestattet.
 Soweit nicht ausdrücklich zugestanden. Zuwiderhandlung
 zuzüglich verpflichten zu Schadensersatz. Alle Rechte über den
 Fall der Patenterteilung oder GEM-Infraktion vorbehalten.

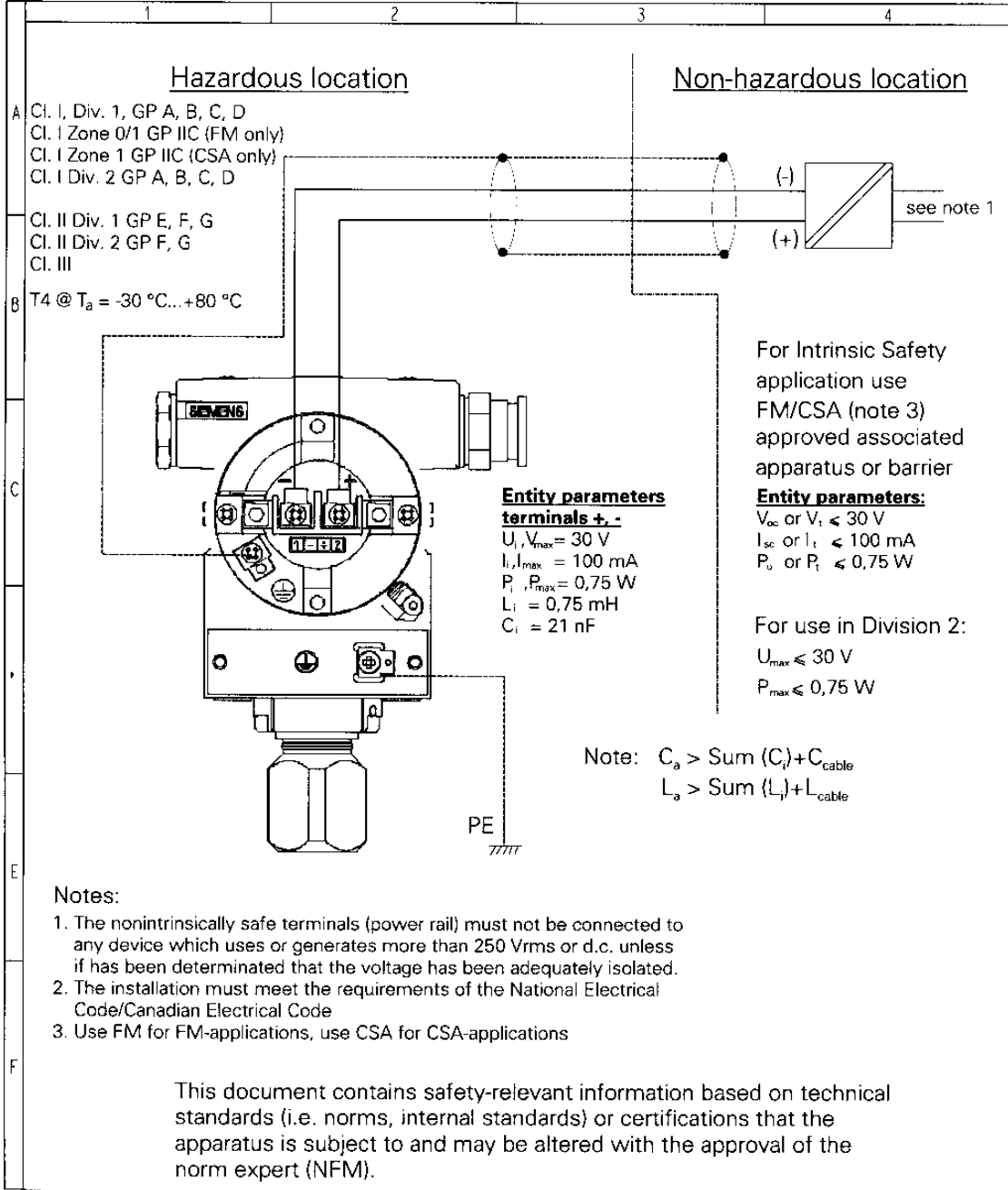

Modellname:		Modelltyp:		Zeichnungsname: MKFMCSA5.ds4		PDM-Obj:	
833		Projektionsschema		engineering obligation for delivery			
05	79A15967	30.04.02	SM	Datum	30.05.00	transmitter SITRANS P MKII type 7MF4010 control drawing (FM, CSA)	PDM-Info:
04	79A15967	12.12.00	SM	Name	S. Mueller		Release Level:
03	79A15967	27.10.00	SM	P-Dat			Revision Code:
02	79A12942	24.08.00	SM	Prüfer			
01	79A12942	18.07.00	VV.S.				
ZS	Mitteilung	Datum	Name	Siemens AG A&D PA11		Blatt 1 von 1 Bl.	
						A5E00072865A	

C.0 APPENDIX C - ELEVATION AND SUPPRESSION CORRECTIONS

When installing a transmitter to measure liquid level, configuration of the Sensor Input Block often must include an adjustment for one of two conditions introduced by the mounting arrangement:

- Elevated Span - The Lower Range Value (LRV) of the transmitter needs to be configured above "0." See Figure C-1.
- Suppressed Span - The LRV of the transmitter needs to be configured below "0." See Figure C-2.

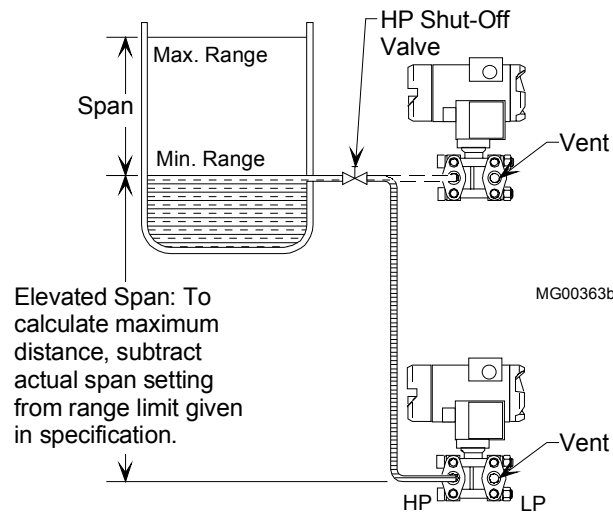

FIGURE C-1 Elevated Span

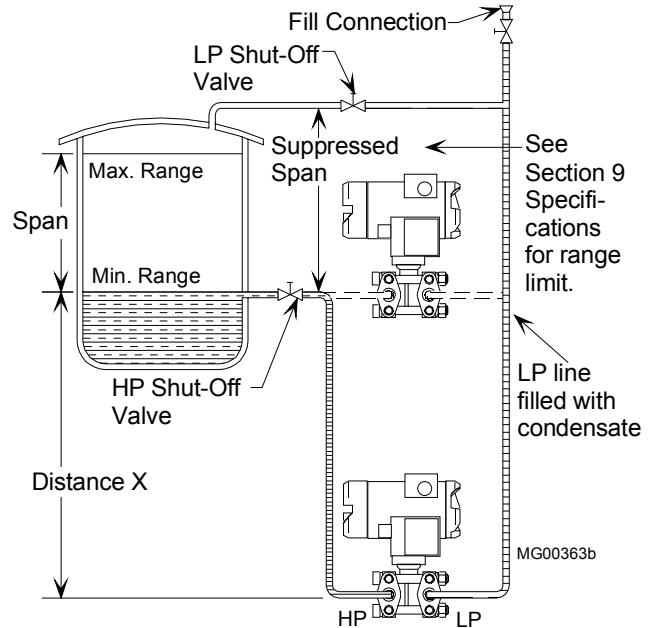

FIGURE C-2 Suppressed Span

A brief discussion of how to make adjustments for elevation and suppression follows. Then two examples of the calculations needed to determine configuration parameters are given. Finally, a brief procedure that does not involve calculations is provided.

C.1 HOW ADJUSTMENT IS MADE

Because the transmitter can handle elevation and suppression simply by setting parameters, it is not necessary to introduce mechanical measures, such as installing piping backwards or adding additional hardware.

The range of the transmitter can be set anywhere, forward or reverse acting, as long as the following criteria are met:

$$\text{LRL} \leq \text{LRV} \leq \text{URL}$$

$$\text{LRL} \leq \text{URV} \leq \text{URL}$$

$$\text{Span} = [\text{URV} - \text{LRV}] \geq \text{Min Span}$$

Note that the URL (Upper Range Limit), LRL (Lower Range Limit), and Min Span are transmitter dependent.

C.2 ELEVATION CALCULATION EXAMPLE

Figure C-3 shows a sample transmitter installation.

1. Calculate the differential pressure as follows.

$$\text{Pressure}_{@DP} = (H \times \text{SpG})_{\text{High Side}} - (H \times \text{SpG})_{\text{Low Side}}$$

where H = Height

2. Calculate the LRV when the tank is empty.

$$\text{LRV} = (120 \times 1.0)_{\text{High Side}} - (0 \times 1.0)_{\text{Low Side}}$$

$$\text{LRV} = +120 \text{ inH}_2\text{O}$$

3. Calculate the URV.

$$\text{URV} = \text{LRV} + \text{Span}$$

$$\text{URV} = +120 + 100$$

$$\text{URV} = 220 \text{ inH}_2\text{O}$$

Therefore, transmitter range should be 120 to 220 inH₂O.

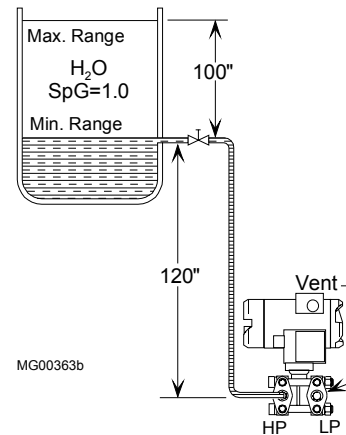

FIGURE C-3 Elevation Calculation

C.3 SUPPRESSION CALCULATION EXAMPLE

Figure C-4 shows a sample transmitter installation.

1. Calculate the differential pressure as follows.

$$\text{Pressure}_{@DP} = (H \times \text{SpG})_{\text{High Side}} - (H \times \text{SpG})_{\text{Low Side}}$$

where H = Height

2. Calculate the LRV when the tank is empty.

$$\text{LRV} = (0 \times 1.0)_{\text{High Side}} - (100 \times 1.0)_{\text{Low Side}}$$

$$\text{LRV} = -100 \text{ inH}_2\text{O}$$

3. Calculate the URV.

$$\text{URV} = \text{LRV} + \text{Span}$$

$$\text{URV} = -100 + 100$$

$$\text{URV} = 0 \text{ inH}_2\text{O}$$

Therefore, transmitter range should be -100 to 0 inH₂O.

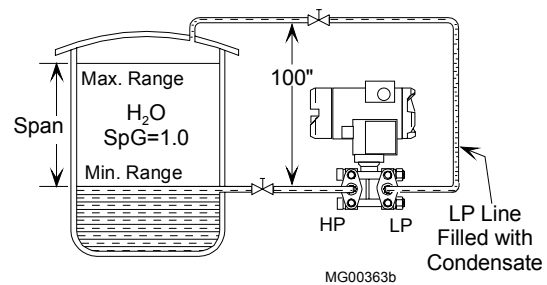



FIGURE C-4 Suppression Calculation

C.4 RECOMMENDED METHOD

An alternative to making the above calculations and entering derived values is to shift the span directly using the HART Communicator while adjusting the process levels.

1. Range the transmitter using the HART Communicator as for a zero-based span (e.g., 0-100 inH₂O).
2. Install the transmitter on the process.
3. Fill the impulse pipe (wet legs) to the transmitter, but maintain the process at 0 (e.g., empty tank).
4. Perform one of the following:
 - HART Communicator - From the Online menu, press 3 Device Setup, 3 Basic Setup, and then 4 LRV. Press ENTER to set the current pressure as the LRV. The configured span will be retained.
 - Local Pushbuttons - Use the M pushbutton to select Mode 7. Set zero by simultaneously pressing the  and  pushbuttons for 2 seconds; the selected current will appear in the display. The configured span will be retained.

This completes the procedure. ■

WARRANTY

- (a) Seller warrants that on the date of shipment the goods are of the kind and quality described herein and are free of non-conformities in workmanship and material. This warranty does not apply to goods delivered by Seller but manufactured by others.
- (b) Buyer's exclusive remedy for a nonconformity in any item of the goods shall be the repair or the replacement (at Seller's option) of the item and any affected part of the goods. Seller's obligation to repair or replace shall be in effect for a period of one (1) year from initial operation of the goods but not more than eighteen (18) months from Seller's shipment of the goods, provided Buyer has sent written notice within that period of time to Seller that the goods do not conform to the above warranty. Repaired and replacement parts shall be warranted for the remainder of the original period of notification set forth above, but in no event less than 12 months from repair or replacement. At its expense, Buyer shall remove and ship to Seller any such nonconforming items and shall reinstall the repaired or replaced parts. Buyer shall grant Seller access to the goods at all reasonable times in order for Seller to determine any nonconformity in the goods. Seller shall have the right of disposal of items replaced by it. If Seller is unable or unwilling to repair or replace, or if repair or replacement does not remedy the nonconformity, Seller and Buyer shall negotiate an equitable adjustment in the contract price, which may include a full refund of the contract price for the nonconforming goods.
- (c) SELLER HEREBY DISCLAIMS ALL OTHER WARRANTIES, EXPRESS OR IMPLIED, EXCEPT THAT OF TITLE. SPECIFICALLY, IT DISCLAIMS THE IMPLIED WARRANTIES OF MERCHANTABILITY, FITNESS FOR A PARTICULAR PURPOSE, COURSE OF DEALING AND USAGE OF TRADE.
- (d) Buyer and successors of Buyer are limited to the remedies specified in this article and shall have no others for a nonconformity in the goods. Buyer agrees that these remedies provide Buyer and its successors with a minimum adequate remedy and are their exclusive remedies, whether Buyer's or its successors' remedies are based on contract, warranty, tort (including negligence), strict liability, indemnity, or any other legal theory, and whether arising out of warranties, representations, instructions, installations, or non-conformities from any cause.
- (e) Note: This article does not apply to any software which may be furnished by Seller. In such cases, the attached Software License Addendum applies.

■

Online Configuration Map for Siemens SITRANS P DSIII Pressure Transmitters (with Model 275 HART COMMUNICATOR)

1 Pressure +											
2 Type +											
3 Device setup	1 Process variables	1 Pressure +									
		2 % range +									
	3 Analog output +										
	4 Sensor temperature +										
	2 Diagnostics/service	1 Diagnosis	1 Min/max pointer	1 Pressure pointer		1 Pressure maximum		2 Pressure minimum			
				3 Reset pointer							
				2 EI Temperature pointer		1 EI Temperature max		2 EI Temperature min		3 Reset pointer	
				3 Sensor temperature pointer		1 Sensor temperature max		2 Sensor temperature min		3 Reset pointer	
				2 Operating hours		1 Operating hours EI					
				2 Operating hours S							
			3 Warnings/alarms	1 W/A time unit							
				2 Calibrate interval		1 Calibrate status		2 W/A acknowledge		3 Calibration timer >	
				4 Calibration warning		5 Calibration alarm		6 W/A activation			
				3 Service interval		1 Service status		2 W/A acknowledge		3 Service timer	
			4 Service warning		5 Service alarm		6 W/A activation				
			4 AO saturation		1 Saturation alarm		2 Alarm duration		3 Alarm activation		
	4 Status	1 Status summary									
		2 Hardware/Firmware status									
		3 Diagnostic alarm status									
		4 Diagnostic warning status									
		5 Simulation status									
	2 Simulation/Test	1 Simulation		1 Loop test		2 Inputs >					
		2 Test		1 Self test		2 Master reset					
	3 Control modes	1 Local keys control mode									
2 Write protect (status)											
3 Set write protect (enable)											
4 Trim	1 Position correction										
	2 Sensor trim		1 Sensor trim points		2 Zero trim		3 Lower sensor trim				
	4 Upper sensor trim		1 D/A trim		2 Scaled D/A trim						
	3 Trim analog output										
5 Restore manufacturer trims	1 All trims										
	2 DAC trims										
	3 Position correction										
	4 Sensor trim										
6 All measured values	1 Pressure +										
	2 Raw value										
	3 Sensor temperature +										
	4 EI Temperature +										
	5 AO +										
3 Basic setup	1 Tag										
	2 (Engineering) units										
	3 Position correction										
	4 LRV										
	5 URV										
	6 Damping										
	7 Transfer function										

Continued in
Figure A-1
Part 2



Notes:

- 1. + = Active data displayed
- 2. HART Communicator, Rev 5; firmware Rev 2.2
- 3. > = To additional menu(s)

Continued on other side.
Siemens Energy & Automation, Inc.
Rev. 1, March 2001

Online Configuration Map for Siemens SITRANS P DSIII, Continued

3 Device setup,
continued in
Figure A-1,
Part 1

4 Detailed setup See Note 4	1 Sensors	1 Pressure sensor	1 Pressure +		
		2 Temperature sensor	2 (Engineering) Units		
	2 Signal condition	1 Process variables	1 Sensor temperature +		
			2 EI temperature +		
			3 AO +		
			4 Sensor Temperature +		
		2 Position correction			
		3 Zero/span set	1 Keypad input		1 LRV
					2 URV
					3 Pressure (Eng.) Units
					4 LSL
					5 USL
		2 Apply values			
		4 Damping			
		5 Transfer function			
		6 Measuring speed			
	3 Output condition	1 Analog output	1 AO +		
			2 Pressure		
			3 Alarms >		
			4 Lower AO limit		
			5 Upper AO limit		
		2 HART output	1 Poll address		
		2 Num request preambles			
		3 Num response preambles			
4 Device information	1 Ranges and limits	1 Module range			
		2 Pressure USL			
		3 Pressure LSL			
		4 Pressure minimum span			
	2 Common device information	1 Manufacturer			
		2 Model			
		3 Measurement type			
		4 Device order number			
		5 Explosion protection			
		6 Device ID			
		7 Pressure sensor S/N			
		8 Final assembly number			
		9 Electrical connector			
		Electrical housing material			
		Write protect			
		Tag			
		Date			
	Descriptor				
	Message				
	3 Sensor information	1 Process connection			
		2 Flange type			
		3 Flange material			
		4 Process flange bolt			
		5 Isolator material			
		6 Fill fluid			
		7 O-ring material			
		8 Drain & vent/plug material			
9 Drain & vent/plug position					
4 Remote seal	1 RS type				
	2 RS isolator material				
	3 RS fill fluid				
	4 Number of remote seal				
	5 Extension length				
5 Local meter	1 Meter type				
	2 Unit tracking				
	3 Local display units				
	4 Bargraph				
6 Revision numbers	1 Universal rev.				
	2 Field device revision				
	3 Software revision				
	4 Hardware revision				
5 Reviews	Step through configuration				

Online Configuration Map for Siemens SITRANS P DSIII Pressure Transmitter with Model 375 Field Communicator

Notes:

1 Model 375 Field Communicator Firmware Rev. F1.6

2 + = active data (measurement) display
M = method (i.e. short procedure)

2 Online	1 Pressure (PV) +			
	2 PV status			
	3 Module type			
	4 Identification	1 Operation Unit	1 Tag	
			2 Ext (Long) Tag --> M	
			3 Descriptor	
			4 Message	
			5 Date	
		2 Device	1 Manufacturer	
			2 Model	
			3 Device identification	
			4 Distributor	
			5 MLFB Order Number	1 MLFB Order No --> M
	3 Basic Parameters	6 Measurement type		
		7 Fabrication-No		
		8 Final assembly number		
		9 Sensor serial number		
		10 Revisions	1 Universal rev.	
			2 Field device rev.	
			3 Software rev.	
4 Hardware rev.				
5 Config Inp/Out	1 Quick-Setup & Meas.	1 PV, Current, Status	1 PV +	
			2 AO (analogue output) +	
			3 PV % range +	
			4 Status see -->	6 Diagnosis/Service
			5 Measurement type	
		2 Meas.Val. & Status	1 Pressure Values	1 Pressure +
				2 Pres status
				3 Untrimmed pressure +
	2 Temperature Values	1 Sens-Temp +		
		2 Sens-Temp status		
	3 Electr-Temp +			
	4 Electr-Temp status			
3 Level, Vol, Mass Values (shown if valid items)	1 Level +			
	2 Level status			
	3 Volume +			
	4 Volume status			
	5 Mass flow +			
	6 Mass status			
4 Vol-, Mass- & Flow Values (shown if valid items)	1 Vol-Flow +			
	2 Vol-Flow status			
	3 Mass-Flow +			
	4 Mass-Flow status			
5 Appl & Stat (shown if valid items)	1 Customer Defined			
	2 Customer Defined Status			
2 Input	1 Config Pres/Temp	1 Pressure sensor	1 Pressure +	
			2 Untrimmed pres +	
			3 Pressure units	1 Pres abs/rel
				2 Pressure unit
				3 Untrimmed pres unit
			2 Temperature sensor	1 Sens-Temp +
				2 Electr-Temp +
				3 Temp units
				2 Electr-Temp unit
3 Pres units see -->	1 Pressure sensor			
4 Temp units see -->	1 Temperature sensor			
2 Display Process Variables	1 Process variables	1 PV measurement +		
		2 PV % range		
		3 AO		
		4 S Temperature +		
		5 EI Temperature +		
		6 Untrimmed pressure +		

Continued on pg 2
↓

**Online Configuration Map for
Siemens SITRANS P DSIII Pressure Transmitter with
Model 375 Field Communicator**

5 Config Inp/Outp,
Continued

2 Input, Continued

3 Meas Switch/Mapper

1 measurement		
2 PV is		
3 SV is		
4 TV is		
5 QV is		
6 (measurement) config e.g. Level	1 Input scaling	1 Pres abs/rel 2 Pressure unit 3 Input LRV 4 Input URV
	2 Level scaling e.g. Level scaling	1 Level unit 2 Level LRV 3 Level URV
	3 Volume scaling	1 Volume unit 2 Vol LRV 3 Vol URV 2 Density unit 3 Density 3 Mass unit
6 (measurement) config e.g. Flow	1 Input scaling	1 Pres abs/rel 2 Pressure unit 3 Input LRV 4 Input URV
	2 Flow scaling	1 Vol flow unit 2 Vol flow LRV 3 Vol flow URV 2 Density unit 3 Density 3 Mass flow unit
6 (measurement) config e.g. Customer	1 Input scaling	1 Pres abs/rel 2 Pressure unit 3 Input LRV 4 Input URV
	3 Customer scaling	1 Cust unit (6 Ch) 2 Cust LRV 3 Cust URV
7 User linearization if Level, Flow or Customer this is valid - otherwise not	1 Special Curve status -->	only if meas not pres
	2 No curve points	
	3 Setup special char --> M	
	4 Display special char --> M	

4 Meas.Limits & Span

1 Module range		
2 Active Device Variables	1 Pressure	1 Pressure unit 2 Pres USL 3 Pres LSL 4 min span 5 Trimpoint sum
	2 Sens-Temp	1 Sens-Temp unit 2 Sens-Temp USL 3 Sens-Temp LSL 4 Sens-Temp min.span
	3 Electr-Temp	1 Electr-Temp unit 2 Electr-Temp USL 3 Electr-Temp LSL 4 Electr-Temp min.span
	4 Untrimmed Pres	1 Untrimmed Pres unit 2 Untrimmed Pres USL 3 Untrimmed Pres LSL 4 Untr Pres min.span
additional if measurement is mapped to level	5 Level	1 Level unit 2 Level USL 3 Level LSL 4 Level min.span
additional if measurement is mapped to level	6 Volume	1 Volume unit 2 Volume USL 3 Volume LSL 4 Volume min.span
additional if measurement is mapped to level	7 Mass	1 Mass unit 2 Mass USL 3 Mass LSL 4 Mass min.span
additional if measurement is mapped to flow	5 Vol-Flow	1 Vol-Flow unit 2 Vol-Flow USL 3 Vol-Flow LSL 4 Vol-Flow min.span
additional if measurement is mapped to flow	6 Mass-Flow	1 Mass-Flow unit 2 Mass-Flow USL 3 Mass-Flow LSL 4 Mass-Flow min.span
additional if measurement is mapped to customer	5 Customer	1 (PV) unit 2 Customer USL 3 Customer LSL 4 Customer min. span

Continued on pg 3



**Online Configuration Map for
Siemens SITRANS P DSIII Pressure Transmitter with
Model 375 Field Communicator**

5 Config inp/out, Continued	3 Output	1 Analog output	1 Analog output +	Linear Sq Rt, lin to Strtpt Sq Rt, 4 mA to Strtpt Sq Rt, 2 steps lin to Startpt					
			2 Percent range +						
			3 Pres xfer function						
			NA/4 Startpoint square root						
			4/5 Zero and Span			1 Zero/Span set	1 Out Scaling PV >1 2 Apply values >2		
			5/6 Current Limits			1 Lower AO Limit 2 Upper AO Limit			
		2 Sensor trim points	6/7 Alarms	1 Lower sensor trim point	1 AO Alarm Type 2 Alarm LRV 3 Alarm URV				
				2 Upper sensor trim point					
				3 HART output		1 Polling address 2 Num request preambles 3 Num response preambles			
		4 Local meter	1 Meter type 2 Unit tracking 3 Local Display unit 4 LCD Settings 5 Bargraph	1 LCD Scaling, if On:	2 LCD Unit 3 LCD LRV 4 LCD URV				
				6 Access Control	1 Local keys control mode 2 Write protect 3 Set write protect --> M				
					5 Mech. Construction Mech = mechanical	1 No of electronic changes 2 Design	1 Sensor	1 Fill fluid 2 Isolation material (diaphr) 3 O ring material 4 Module range	
	2 Remote Seal							1 Number remote seal (RS) 2 RS type 3 RS isolator material 4 RS fill fluid 5 Extension length 6 Extension type 7 Capillary length	
				3 Process Connection		1 Process Connection 2 DrainVent / plug mat 3 DrainVent / plug pos 4 Process flange bolt 5 Flange type 6 Flange material			
	4 Electronic Connection		1 Electr housing material 2 Electr connection						
	6 Diagnosis/Service		1 Status	1 Status summary	OFF = OK ON = Problem				
				2 Extended device status					
		3 Hardw/Firmw status		1 RAM failure 2 ROM failure 3 Electronic EEPROM # List continues					
				4 Diag Alarm Status		1 Calibration Alarm 2 Service Alarm # List continues			
						5 Diag Warn Status	1 Calibration Warning 2 Service warning # List continues		
		6 Simulation status		1 Pressure simulation 2 EI simulation 3 Sensor temp simulation					
				2 Device		1 Selftest/Reset	1 Selftest --> M 2 Display Test --> M 3 Master reset --> M 4 Changes Config	1 Config changed counter mfr = manufacturer	
							2 Sensor trim	1 Restore mfr trims --> M 2 Sensor trim	1 Sensor trim points 2 Sensor trim
		3 Trim analog output						1 D/A trim --> M 2 Scaled D/A trim --> M	
4 Position correction		1 Position corr --> M							
3 Simulation/Test		1 Loop test --> M 2 Inputs --> M				Simulation AO Simulation Fixed / Ramp			
		4 Access Control				1 Local keys control mode 2 Write protect 3 Set write protect --> M			

Continued on pg 4



**Online Configuration Map for
Siemens SITRANS P DSIII Pressure Transmitter with
Model 375 Field Communicator**

6 Diagnosis/Service, Continued	3 Diagnostic settings	1 W/A time unit	W/A = warning/alarm		
		2 Calib interval	1 Calib status		
			2 W/A acknowledge --> M		
			3 Calib timer		1 Calib time
					2 Reset timer --> M
			4 Calib warning		
			5 Calib alarm		
		3 Service interval	6 W/A activation		
			1 Service status		
			2 W/A acknowledge --> M		
			3 Service timer		1 Service time
					2 Reset timer --> M
			4 Service warning		
		4 AO saturation	5 Service alarm		
			6 W/A activation		
			1 AO alarm type		
			2 Saturation alarm		
		5 Limiter setup	3 Alarm duration		
	4 Alarm activation				
	1 Display limiter --> M				
	2 Setup limiter --> M				
	3 Limiter status --> M				
	4 Limiter: Ack W/A --> M				
	4 View	1 Operating hours	5 CmpCnt: Ack W/A --> M		
6 Reset counter. --> M					
7 Certif & Approv Certif=Certification Approv=Approval	1 Explos. Protection Explos = Explosion	1 Operating hours Electr			
		2 Operating hours Sensor			
	3 Min/Max pointer	1 Pressure pointer	1 Pres max		
			2 Pres min		
			3 Reset pointer --> M		
		2 Electr-Temp pointer	1 Electr-Temp max		
			2 Electr- Temp min		
			3 Reset pointer --> M		
	3 Sens-Temp pointer	1 Sens-Temp max			
		2 Sens-Temp min			
3 Reset pointer --> M					

Ack = acknowledge
CmpCnt = Comparison Counter