

# STT 3000 Series STT250

## Smart Temperature Transmitters Specifications

### Models STT25H, STT25S, STT25M, STT25D

#### EN0I-6031 March 2010



### Introduction

Honeywell's STT 3000 family of microprocessor based smart temperature transmitters includes both the Series STT250 described in this specification sheet and the higher performance STT350 described in Product Specification Sheet EN0I-5222. The STT350 offers high performance and advanced functionality. The STT250 units offer competitive performance in a more compact module and with a wider range of smart communications protocols.

- STT25H with HART™ protocol when this popular protocol is preferred. Configuration of the HART unit can be made with any of the listed HART Communication Foundation tools.
- STT25S with HART 6 protocol and TUV SIL 2 approval. Configuration of the HART unit can be made with any of the listed HART tools
- STT25M for 4-20mA operation and local/ remote configuration via Honeywell's digital DE protocol from the Smart Field Communicator (SFC) or Smart Configuration Toolkit PC based software (SCT).
- STT25D with digital DE protocol for either 4-20mA operation or digital integration into the TDC 3000™/ TPS 3000™ control system.

**Note** that the latest addition to the STT250 family is the Dual Input **STT25T**. The two sensor inputs may be used for sensor cross checking or for sensor redundancy. This is described in separate Product Specification Sheet EN0I-6091.

All units support the same wide range of primary sensor types, are 2 wire powered and give an output linearized to temperature over the 2 power wires. Lead wire compensation is provided for RTD (Resistance Temperature Detectors) and internal digital cold junction compensation is provided for Thermocouples. Millivolt and Ohms sensor inputs can also be accepted.

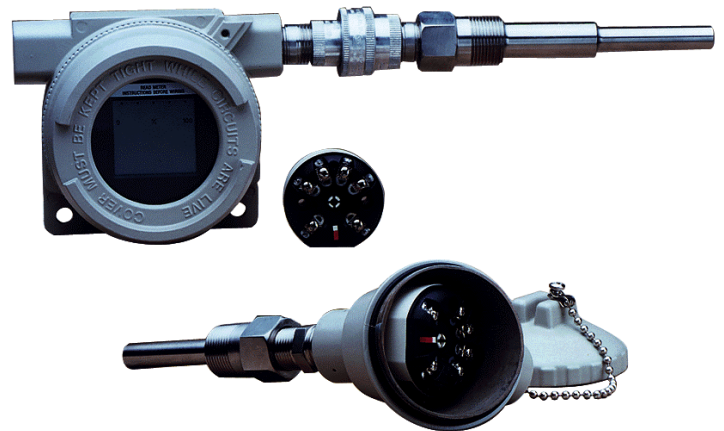

### Features

- Smart communication protocols available include HART or DE Honeywell.
- Direct sensor head mounting in DIN Form A housing. Housing materials available include plastic, aluminum, 316SS and cast iron.
- Mounting options include wall, pipe, DIN rail or direct sensor head mounting with or without a housing.
- Single model accepts input signal from a wide choice of primary sensors to satisfy varying application requirements with minimum transmitter inventory.
- Suitable for 4, 3 or 2 wire Pt100 and Pt200 RTD measurement.
- Hard wired upscale/ downscale failsafe link to ensure secure operation in the event of a failure.
- Open circuit sensor analysis carried out in every measurement cycle.
- Selectable latching/non-latching failsafe operation for open circuit sensor.
- Integral analogue or digital indication meter option.
- Analogue to Digital converter validated frequently

## Description

The STT250 transmitters are suitable as replacements for any conventional or most smart temperature transmitters in use today. The memory contains the characteristics of most commonly used temperature sensors.

You can easily use the hand held communicator or PC tool to configure the transmitter for any of these sensors and it will automatically correct for their associated non-linearity's.

Accuracies stated below are available merely by selecting the sensor type and range (i.e. without user calibration).

Calibration of the LRV/URV end points will typically give accuracy improvements of 2 times. Sensor errors can be calibrated out by calibration to the specific sensor either by having it at the LRV/URV temperatures or by simulation of the known values.

In addition, all units pass through Environmental Stress Screening by fast cycling between -40°C and +85°C to ensure maximum product reliability. During this process the ambient temperature coefficients are determined for each unit and burned into memory to ensure temperature compensation over a wide range of operating conditions.

Configuration adjustments and diagnostics checks can be made either locally or remotely over the signal wires from anywhere along their route. This enables major savings in manpower time during commissioning, start up and maintenance activities.

## Performance Under Rated Conditions

Sensor	Digital Accuracy over Normal Range		D/A Accuracy % of span	Digital Accuracy over Maximum Range		Standards
	°C	(°F)		°C	(°F)	
Pt100	0.15C for -200 to 450	(-328 to 842)	0.025%	0.25C for -200 to 850C	(-328 to 1562)	IEC751(ITS-90)( $\alpha=0.00385$ )
Pt200	0.30C for -200 to 450	(-328 to 842)	0.025%	0.40C for -200 to 850C	(-328 to 1562)	IEC751(ITS-90)( $\alpha=0.00385$ )
Pt100J	0.15C for -200 to 450	(-328 to 842)	0.025%	0.25C for -200 to 640C	(-328 to 1184)	JISC1604-81( $\alpha=0.00392$ )
$\Omega$	0.40 $\Omega$ for 0 to 1000 $\Omega$		0.025%	0.40 $\Omega$ for 0 to 2,000 $\Omega$ *		
mV	15 $\mu$ V for -20 to 120mV		0.025%	15 $\mu$ V for -20 to 120mV		
B	1.0C for 550 to 1820	(1022 to 3308)	0.025%	3.0C for 200 to 1,820C	(392 to 3308)	IEC 584-1(ITS-90)
E	0.30C for 0 to 1000	(32 to 1832)	0.025%	0.60C for -200 to 1,000C	(-328 to 1832)	IEC 584-1(ITS-90)
J	0.30C for 0 to 800	(32 to 1472)	0.025%	0.70C for -200 to 1,200C	(-328 to 2192)	IEC 584-1(ITS-90)
K	0.60C for -120 to 1370	(-191 to 2498)	0.025%	0.90C for -200 to 1370C	(-328 to 2498)	IEC 584-1(ITS-90)
N	0.40C for 0 to 1300	(32 to 2372)	0.025%	1.5C for -200 to 1300C	(-328 to 2372)	IEC 584-1(ITS-90)
R	0.60C for 500 to 1760	(932 to 3200)	0.025%	1.0C for -50 to 1760C	(-58 to 3200)	IEC 584-1(ITS-90)
S	0.60C for 500 to 1760	(932 to 3200)	0.025%	1.0C for -50 to 1760C	(-58 to 3200)	IEC 584-1(ITS-90)
T	0.30C for -100 to 400	(-148 to 752)	0.025%	0.5C for -250 to 400C	(-418 to 752)	IEC 584-1(ITS-90)

\* \* 4 wire ohms input only and limited to 0 to 1,000 Ohms for model STT25D

## Specifications

### Operation Conditions

Parameter	Reference Condition	Rated Condition	Operative Limits	Transportation And Storage
Ambient temperature °C	23 °C ± 2	-40 to +85	-40 to +85	-50 to +100
Humidity				
Rack mounted % RH	10 to 55	5 to 95	5 to 100	5 to 100
In field housing % RH	10 to 55	5 to 100	5 to 100	5 to 100
Supply voltage	Voltage range 10.8 to 35 Vdc at the transmitter terminals			
Output current	Current over range 3.8 to 20.8 mA. Failsafe limits < 3.8 and 21.8 mA			
Load resistance	0 to 1110Ω			
Vibration	Maximum of 4g over 15 to 200Hz (restricted to 3g with indication meter).			
Shock	Maximum of 40g.			

### Performance Specifications

*Output D/A accuracy:* ±0.025% of span

*Cold Junction accuracy:* ±0.5°C

*Total reference accuracy:* Analogue 4-20mA mode = Digital accuracy + Output D/A accuracy + CJ accuracy (T/Cs only)

*Total reference accuracy:* Digital DE mode = Digital accuracy + CJ accuracy (T/Cs only).

(example: transmitter operating in analogue mode with Pt100 sensor and 0 to 200°C range.

*Total reference accuracy =*  
 $0.15 + (200/100) * 0.025 = 0.2\%$

*Digital ambient temperature effect* (per 10°C change from 23°C ref.): RTDs or Ohms : 0.050% of reading in Ohms. : T/Cs or mV : 0.080% of reading in mV.

*Output D/A ambient temp. effect* (per 10°C change from 23°C ref.): ±0.045% of span.

*Cold Junction ambient temperature effect:* 40: 1 rejection for ambient temperature changes from 23°C reference.

*Total Reference Accuracy* (Reference – Includes combined effects of linearity, hysteresis, and repeatability)

*Total output ambient temperature effect :* Analogue 4-20mA mode = Digital effect + Output D/A effect + CJ effect (T/Cs only).

*Total output ambient temperature effect:* Digital DE mA mode = Digital effect + CJ effect (T/Cs only).

*Power supply voltage effect:* 0.005% of Max span per Volt.

*Stability/time drift:* 0.05% of max span per year.

#### Additional Parameters

*Output:* 4-20mA or Honeywell digital DE protocol. HART and DE available with 4-20mA output.

*Adjustment range:* No limits to adjustments within the Maximum Range except minimum span limit of 1 engineering unit e.g. 1°C

*Damping time constant:* Adjustable from 0 to 102 seconds digital damping.

*Output response time:* 1 second to reach 63% of final value with 0 secs damping.

*Output update time* 0.5 secs approximately.

Input/ output galvanic isolation  
 Withstands 500Vac dielectric strength test for 1 minute.

*Sensor open circuit*  
 Open circuit/ burnout detection is user selectable. Upscale or downscale with critical status message. Latching or non-latching sensor burnout action.

*Common mode rejection*  
 120dB (1 million to 1) from 50Hz to 50 kHz.

*Series mode rejection*  
 40dB (100 to 1) for 50 or 60Hz ±0.5Hz. (with internal software filter set to local power line frequency).

*EMC compliance*  
 In compliance with 2004/108/EC, Electromagnetic Compatibility (EMC) Directive.

*Radiated RF Immunity:* ±0.15% of span at 10V/m over 80 to 1,000MHz.

**Physical Mounting and Construction**

The STT250 Temperature Transmitter is designed to be mounted in a DIN Form A housing for direct installation with the temperature sensor or can be provided in a remote pipe or wall mount housing. Details for the various housings available are referenced in the table below. The STT250 Temperature Transmitter module can also be DIN rail mounted to a top hat or “G” rail via a clip. Integral meters available

**Integral Meters**

Honeywell’s Series STT250 Temperature Transmitters can be supplied with local or remote indication. An Analogue, Engineering Units or a Smart meter can be mounted integral to the transmitter inside the field mount housing. Order an integral meter as part of the model number; Table II \_\_ M, \_\_ E and \_\_ S, respectively. Order a remote meter as model RMA300. The analogue meter is a 4-20mA moving coil type and displays the temperature in 0 to 100% span.

The E. U. meter displays temperature in engineering units with the STT25H, STT25T and STT25S HART units. Refer to 34-ST-25-08D for more details. The Smart meter accepts 4-20mA or DE protocol and displays temperature on a LCD in engineering units or 0 to 100% span.

The remote digital meter reads DE protocol and displays temperature on a LCD in 0 to 100% span. Refer to 34-ST-25-07A for details.

**STT250 Module Dimensions (in/mm)**

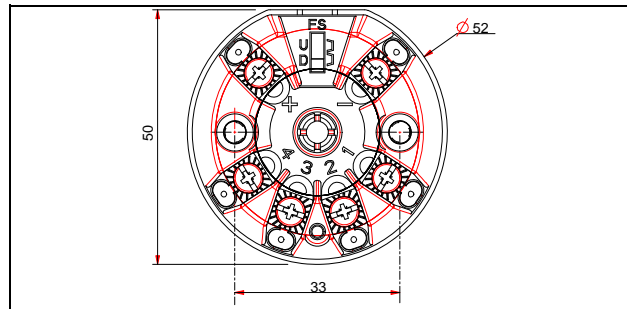
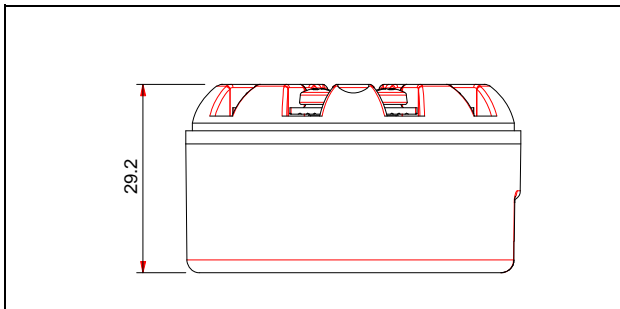

**STT250 Connections**

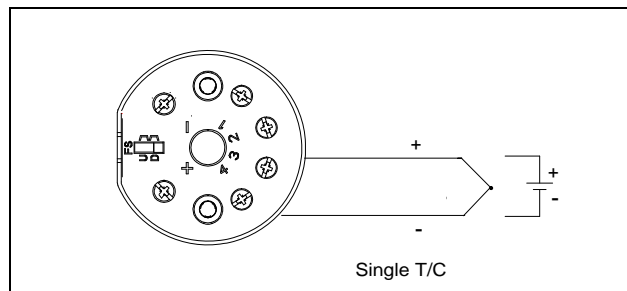
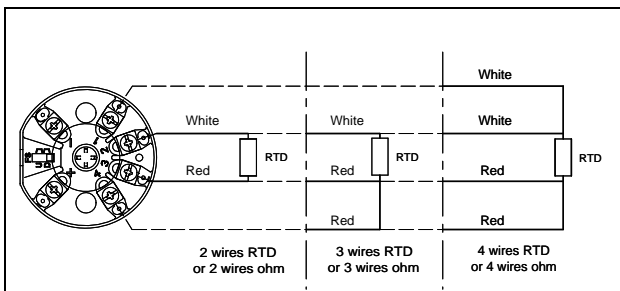

**Materials of Construction**

Terminal Block	Noryl
Connection Screws	M3 Nickel plated brass
Module Housing	Cycloy (PC/ABS) with metallized interior surface
Weight	0.075 kg (0.2 lbs)

## Approvals

The STT250 Temperature Transmitter module is Intrinsically Safe to ATEX, IECEx , SAEx, FM and CSA standards when used with a suitable safety barrier. It is zone 2 and explosion-proof to ATEX, IECEx, SAEx, FM and CSA standards when installed in a suitable housing. See the Model Selection Guide Table VII in this Specification Sheet for detailed safety approvals covering both the STT250 module only or for the STT250 module supplied in a housing

## Probe and Thermo well Availability

STT250 can be supplied complete with a wide range of thermo wells, thermocouples or RTD sensors. See documents listed in the table below.

STT820 Series	34-44-16-08	Rigid Probe Assemblies.
STT830 Series	34-44-16-09	Threaded and Socket Weld Thermo well Assemblies with Transmitter Option.
STT840 Series	34-44-16-10	Drilled Flange Thermo well Assemblies

Model Selection Guides are subject to change and are inserted into the specifications as guidance only. Prior to specifying or ordering a model check for the latest revision Model Selection Guides which are published at: <http://hpsweb.honeywell.com/Cultures/en-US/Products/Instrumentation/ProductModelSelectionGuides/default.htm>

## Model Selection Guide

# Honeywell

## STT 3000 Temperature Transmitter Series STT250



Model Selection Guide  
34-44-16-03 Issue 35

### Instructions

- Choose availability column based on mounting configuration.
- A dot (•) denotes unrestricted availability. A letter denotes restricted availability.
- Blank denotes unavailable - choose alternate mounting. Restrictions follow Table VII.
- Select the desired Key Number based on the desired communications protocol.
- Select options and approvals from Tables.

Key Number    I    II    III    IV    V    VI    VII  
 STT25\_ - \_ - \_ - \_ - \_ - \_ - \_

### HOW WILL THE UNIT BE MOUNTED?

Module only (no housing), to be DIN rail or wall mounted

Module to be "head mounted" directly to the sensor in smaller housing

Module to be "field mounted" in Explosion-Proof housing remotely from or directly to the sensor

### Key Number

Description	Selection	Availability		
Smart Temperature Transmitter Module				
4-20mA Output, SFC/SCT Configurable	STT25M	•	•	•
HART 5, Protocol, 4-20mA Output	STT25H	•	•	•
HART 6, Protocol, 4-20mA Output	STT25S	•	•	•
Digital DE/ 4-20mA Output, for Digital Integration	STT25D	•	•	•
Dual input, HART Protocol, 4-20mA output	STT25T	•	•	•
All modules carry the following approvals: CE Mark for compliance to EN 50081-2 and 50082-2 Russian Certificate of Pattern Approval No. 2064 of Jan. 1998 Choose additional safety approvals required in Table VII				

**TABLE I - Sensor, Probe and Thermowell Accessories**

No Integral Sensor Probe or Thermowell Supplied	0	•	•	•
---	---	---	---	---

**TABLE II - Transmitter Housing and Integral Meters** (Reference EN01-6032 for details)

Housing	No Housing Supplied	0__		•
	Field : Explosion-Proof Aluminum with Beige Epoxy Coating	E__	•	
	Mount (2): Explosion-Proof 316 Stainless Steel	T__	•	
	Head Mt : Type 4X housing - Beige	C__		•
Cable/ Conduit Entry	Not Applicable - No Housing Supplied	_0_		•
	1/2" NPT Cable/ Conduit Entry	_N_	•	•
	M20 x 1.5 Cable/ Conduit Entry	_M_		•
Integral Meter	No Integral Meter Supplied	__0	•	•
	Analog Meter for Field Mount Housing	__M	•	
	E.U. Meter for Field Mount Housing	__E	h	
	Smart Meter for Field Mount Housing (3)	__S	i	

<sup>(2)</sup> With a Field Mount Housing, 20 characters max. of customer information is available on the nameplate at no charge. (See 13:STT-OE pages for ordering instructions.)

<sup>(3)</sup> For the STT25D and STT25M transmitters

**HOW WILL THE UNIT BE MOUNTED?****Availability**

Module only (no housing), to be DIN rail or wall mounted

Module to be "head mounted" directly to the sensor in smaller housing

Module to be "field mounted" in Explosion-Proof housing remotely from or directly to the sensor

**TABLE III - Configuration, Tagging and Manual****Selection**

Configuration	None - Factory Default Configuration Supplied	0 __	•	•	•
	Transmitter Configuration (See 13:STT-OE pages for choice)	T __	•	•	•
Customer Tagging (4)	No Tagging Required	_ 0 _	•	•	•
	316 SS Wired-on Customer I.D. Tag (4 lines, 28 chars. per line, customer specified information)	_ T _	•	•	
	316 SS Wired-on Customer I.D. Tag (blank)	_ B _	•	•	
Operator's Manual (5)	None	__ 0	•	•	•
	English Language Version	__ E	•	•	•
	French Language Version	__ F	•	•	•
	Spanish Language Version	__ S	<b>b</b>	<b>b</b>	<b>b</b>
	Chinese Language Version	__ C	<b>b</b>	<b>b</b>	<b>b</b>

**TABLE IV - Optional Equipment**

Mounting Arrangement	No Mounting Arrangement Supplied	0 __	•	•	•
	Carbon Steel Mounting Bracket for 2" Pipe	M __	•		
	Stainless Steel Mounting Bracket for 2" Pipe	S __	•		
	Spring Loading Mounting set	L __		•	•
	DIN Rail Mounting via Clip (to Top Hat or "G" Rail)	D __			•
316 SS Conduit Adaptor for Wiring Entry	No Adaptor(s) Supplied	_ 0 _	•	•	•
	1/2" NPT to M20 x 1.5 : 1 Adaptor	_ 1 _	•	•	
	(EEx d IIC approved) : 2 Adaptors	_ 2 _	•	•	
	1/2" NPT to 3/4" NPT : 1 Adaptor	_ 3 _	•		
Lightning Protection	No Lightning Protection Supplied	__ 0	•	•	•
	Externally Mountable to Field Mount Housing	__ L	e		
	Internal Surge/ Lightning Protection	__ S	•		

**TABLE V - Optional Extended Warranty Coverage & Certificates**

Optional Extended Warranty	Standard Warranty	0 __	•	•	•
	Additional Warranty - 1 year	1 __	•	•	•
	Additional Warranty - 2 years	2 __	•	•	•
	Additional Warranty - 3 years	3 __	•	•	•
Optional Certificate (5)	No Transmitter Configuration/ Calibration Certificate	_ 0 _	•	•	•
	Transmitter Configuration/ Calibration Certificate	_ D _	•	•	•
	No Certificate of Conformance/ Origin	__ 0	•	•	•
	Certificate of Conformance/ Origin	__ C	•	•	•

**TABLE VI - Additional Features**

SIL2	No SIL2 - TUV Certified Transmitter	00	•	•	•
	SIL2 - TUV Certified Transmitter (requires HART 6)	S2	<b>d</b>	<b>d</b>	<b>d</b>

(4) Full model number does not appear on module or head mount housing.  
If model number is to appear on unit, order wired on tag.











(5) Chosen Operator's Manuals and chosen Certificates are automatically shipped with unit.  
See 13:STT-OE pages for additional manuals and alternate shipping.

**HOW WILL THE UNIT BE MOUNTED?****Availability***Module only (no housing), to be DIN rail or wall mounted**Module to be "head mounted" directly to the sensor in smaller housing**Module to be "field mounted" in Explosion-Proof housing remotely from or directly to the sensor***TABLE VII - Safety Approvals (6)**

Approval Body	Approval Type	Location or Classification	Selection			
None	No approval body certifications included		00	•	•	•
Factory Mutual	Explosion-Proof	Class I, Div. 1, Groups A,B,C,D	1C	f		
	Dust Ignition-Proof	Class II, III Div. 1, Groups E,F,G				
	Intrinsically Safe	Class I, II, III, Div. 1, Groups A,B,C,D,E,F,G				
	Non-Incendive	Class I, Div. 2, Groups A,B,C,D Suitable for Class II, III, Div. 2, Groups F, G				
	Outdoor Location	Enclosure Rated NEMA 4X				
	Explosion-Proof	Class I, Div. 1, Groups B,C,D	1J	•		
	Dust Ignition-Proof	Class II, III, Div. 1 Groups E,F,G				
	Intrinsically Safe	Class I, II, III, Div. 1, Groups A,B,C,D,E,F,G				
	Non-Incendive	Class I, Div. 2, Groups A,B,C,D Suitable for Class II, III, Div. 2, Groups F, G				
	Outdoor Location	Enclosure Rated NEMA 4X				
	Intrinsically Safe	Class I, II, III, Div. 1, Groups A,B,C,D,E,F,G	1G	•		
	Non-Incendive	Class I, Div. 2, Groups A,B,C,D Suitable for Class II, III, Div. 2, Groups F, G				
Outdoor Location	Enclosure Rated NEMA 4X					
Intrinsically Safe	Class I, Div. 1, Groups A,B,C,D	1G		•	•	
Non-Incendive	Class I, Div. 2, Groups A,B,C,D					
CSA	Explosion-Proof	Class I, Div. 1, Groups B,C,D	2J	•		
	Dust Ignition-Proof	Class II, III, Div. 1, Groups E,F,G				
	Intrinsically Safe	Class I, II, III, Div. 1, Groups A,B,C,D,E,F,G				
	Non-Incendive	Class I, Div. 2, Groups A,B,C,D Suitable for Class II, III, Div. 2, Groups F, G				
	Outdoor Location	Enclosure Rated Type 4X	2G	•		
	Intrinsically Safe	Class I, II, III, Div. 1, Groups A,B,C,D,E,F,G				
	Non-Incendive	Class I, Div. 2, Groups A,B,C,D Suitable for Class II, III, Div. 2, Groups F, G				
	Outdoor Location	Enclosure Rated Type 4X				
Intrinsically Safe	Class I, Div. 1, Groups A,B,C,D	2G		•	•	
Non-Incendive	Class I, Div. 2, Groups A,B,C,D					

continued next page

TABLE VII - Safety Approvals (6) Continued

Approval Body	Approval Type	Location or Classification	Selection			
ATEX*	Intrinsically Safe Zone 0/1	 Ex ia IIC T6 (Ta = -50°C to +40°C) T5 (Ta = -50°C to +55°C) T4 (Ta = -50°C to +85°C) (Module)	3S	•	•	•
	Flameproof, Zone 1	 Ex d IIC T6 (Ta = -50°C to +80°C) T5 (Ta = -50°C to +85°C) Ex tD A21 T80°C (Ta = 80°C) T95°C (Ta = 85°C) Enclosure rated IP 66/67	3D	p		
	Non-Sparking Zone 2	 Ex nA, IIC T6*	3N	•	•	•
	Multiple Marking** Int. Safe, Zone 0/1, or Flameproof, Zone 1, or Non-Sparking, Zone 2	 Ex ia IIC T6 (Ta = -50°C to +40°C) T5 (Ta = -50°C to +55°C) T4 (Ta = -50°C to +85°C) <hr/>  Ex d IIC T6 (Ta = -50°C to +80°C) T5 (Ta = -50°C to +85°C) Ex tD A21 T80°C (Ta = 80°C) T95°C (Ta = 85°C) <hr/>  Ex nA, IIC T6 (Ta = -50°C to +85°C) (Honeywell) Enclosure Rated IP 66/67	3H	p		
SAEx (South Africa)	Intrinsically Safe Zone 0/1	SAEx  Ex ia IIC S/08-371X T6 (Ta = -50°C to +40°C) T5 (Ta = -50°C to +55°C) T4 (Ta = -50°C to +85°C)	Z2	•	•	•
	Flameproof, Zone 1	SAEx  Ex d IIC S/08-372X T6 (Ta = -50°C to +80°C) T5 (Ta = -50°C to +85°C) Ex tD A21 T80°C (Ta = 80°C) T95°C (Ta = 85°C) Enclosure rated IP 66/67	ZD	•	•	•
	Intrinsically Safe Zone 0/1 and Flameproof, Zone 1	SAEx  Ex ia IIC S/08-371X T6 (Ta = -50°C to +40°C) T5 (Ta = -50°C to +55°C) T4 (Ta = -50°C to +85°C) <hr/> SAEx  Ex d IIC S/08-372X T6 (Ta = -50°C to +80°C) T5 (Ta = -50°C to +85°C) Ex tD A21 T80°C (Ta = 80°C) T95°C (Ta = 85°C) Enclosure rated IP 66/67	ZA	•	•	•
IECEX	Flameproof, Zone 1 (with IS transmitter)	Ex d IIC; T6 (Ta = -50 to +80°C) T5 (Ta = -50 to +85°C) Ex tD A21 IP6X T80°C (Ta = -50 to +80°C) Ex tD A21 IP6X T95°C (Ta = -50 to +85°C)	CB	•	•	•
	Intrinsically Safe Zone 0/1	Ex ia IIC; T6 (Ta = -50 to +40°C) T5 (Ta = -50 to +55°C) T4 (Ta = -50 to +85°C)	CS	•	•	•
INMETRO (Brazil)	Flameproof, Zone 1	BR Ex d IIC T6, T5, T4 Enclosure rated IP 66/67	6D	p		
	Intrinsically Safe, Zone 0/1	BR Ex ia IIC T6, T5, T4 (Module)	6S	b	b	b

**(6) The module itself is rated intrinsically safe, IP20. An appropriately rated enclosure is required for Outdoor and Dust locations.**

\* Module must be installed in IP54 or better housing for Zone 2 approval validity.

\*\* The user must determine the type of protection required for installation of the equipment. The user shall then check the box (  ) adjacent to the type of protection used on the equipment certification label. Once a type of protection has been checked on the label, the equipment shall not be reinstalled using any of the other certification type.

**RESTRICTIONS**

Restriction Letter	Available Only With		Not Available With	
	Table	Selection	Table	Selection
<b>b</b>			Key No.	STT25T
<b>d</b>	Key No.	STT25S		
<b>e</b>			VII	3D
<b>f</b>	II	ENO, TNO,		
<b>g</b>	Key No.	STT25H, STT25M		See Note 6
<b>h</b>	Key No.	STT25H, STT25T, STT25M, STT25S		
<b>i</b>	Key No.	STT25M, STT25D		
<b>p</b>	II	E __, T __		

**Notes:** (6) The module itself is rated intrinsically safe, IP20. An appropriately rated enclosure is required for Outdoor and Dust locations.

See 13:STT-9 or Operator's Manual EN11-6190 for part numbers.

See 13:STT-OE pages for Order Entry Information including tagging, transmitter configuration, manuals, certificates, drawings and SPINS.

To request a quotation for a non-published "special", fax RFQ to Marketing Applications at (1) 602 313-6155.

**Ordering Example: STT25M-0-000-000-000-000-00-1C**

*This page has been intentionally left blank*

**For More Information**

Learn more about how Honeywell's STT3000 Smart Temperature Transmitters can increase performance, reduce downtime and decrease configuration costs, visit our website [www.honeywell.com/ps](http://www.honeywell.com/ps) or contact your Honeywell account manager.

**Automation & Control Solutions**

Process Solutions

Honeywell

2500 W. Union Hills Dr.

Phoenix, AZ 85027

Tel: 877.466.3993 or 602.313.6665

[www.honeywell.com/ps](http://www.honeywell.com/ps)

The Honeywell logo is displayed in a bold, red, sans-serif font.

EN0I-6031  
March 2010  
© 2008-10 Honeywell International Inc.