

TSXCTY2CC

2 channels measurement and counter module -
1000kHz - 15mA (24VDC), 850mA (5VDC)

Product availability : Stock - Normally stocked in distribution facility

Price* : 4968.00 USD



Main

Range of product	Modicon Premium Automation platform
Product or component type	Measurement and counter module
I/O modularity	2 channels
Electrical circuit type	Auxiliary output

Complementary

Counting frequency	1000000 Hz
Incremental encoder frequency x1	500 kHz
Incremental encoder frequency x 4	250 kHz
Power dissipation in W	7...10 W
Cycle time	1 ms
Discrete input logic	Current sink auxiliary input (preset, enable and read) conforming to IEC 1131 Type 2 Resistive 2/3-wire proximity sensors PNP/NPN conforming to IEC 1131 Type 2 Resistive encoder input
Input logic	Positive
Input compatibility	Absolute encoder SSI serial output Incremental encoder 10...30 V totem pole Incremental encoder 5 V DC RS422 Absolute encoder parallel output ABE7CPA11
Input voltage	24 V 16 mA 2/3-wire proximity sensors PNP/NPN 24 V 8 mA auxiliary input (preset, enable and read) 5 V 18 mA encoder input
Input voltage limits	<= 5.5 V encoder input 19...30 V 2/3-wire proximity sensors PNP/NPN 19...30 V auxiliary input (preset, enable and read)
Voltage state 1 guaranteed	>= 11 V 2/3-wire proximity sensors PNP/NPN >= 11 V auxiliary input (preset, enable and read) >= 2.4 V encoder input
Current state 1 guaranteed	>= 6 mA 2/3-wire proximity sensors PNP/NPN

	>= 6 mA auxiliary input (preset, enable and read) >= 3.6 mA encoder input
Voltage state 0 guaranteed	<= 1.2 V encoder input <= 5 V 2/3-wire proximity sensors PNP/NPN <= 5 V auxiliary input (preset, enable and read)
Current state 0 guaranteed	<= 1 mA encoder input <= 2 mA 2/3-wire proximity sensors PNP/NPN <= 2 mA auxiliary input (preset, enable and read)
Response time	< 10 ms sensor voltage at return of 24 V auxiliary input (preset, enable and read) < 2.5 ms sensor voltage at loss of 24 V auxiliary input (preset, enable and read)
Input impedance	> 270 Ohm at U = 2.4 V encoder input 1500 Ohm at Un 2/3-wire proximity sensors PNP/NPN 3400 Ohm at Un auxiliary input (preset, enable and read) 400 Ohm at Un encoder input
Output voltage	24 V DC
Nominal output current	0.5 A
Output voltage limits	19...30 V
Voltage drop	< 0.5 V at state 1
Output compatibility	Positive logic DC inputs (resistance <= 15 kOhm) auxiliary output
Leakage current	< 0.1 mA
Switching time	< 250 ms
Switching frequency	< 0.6/LI ² Hz on inductive load
Output overload protection	Current limiter Thermal tripping via program or automatically
Output short-circuit protection	Current limiter Thermal tripping via program or automatically
Output overvoltage protection	Zener diode
Reverse polarity protection	Reverse diode on supply
Checks	Sensor power supply
Current consumption	15 mA 24 V DC 850 mA 5 V DC
Module format	Standard
Local signalling	2 LEDs green axis diagnostics available (CH.) 1 LED green module operating (RUN) 1 LED red external fault (I/O) 1 LED red internal fault, module failure (ERR)
Electrical connection	1 connector HE-10 20 pins 2 connectors SUB-D 15
Product weight	0.75 lb(US) (0.34 kg)

Environment

Protective treatment	TC Conformal coating Humiseal 1A33
Ambient air temperature for operation	32...140 °F (0...60 °C)
Ambient air temperature for storage	-13...158 °F (-25...70 °C)
Relative humidity	5...95 % without condensation
Operating altitude	<= 6561.68 ft (2000 m)

Ordering and shipping details

Category	22558 - TSX PREMIUM, ATRIUM & PL7 PRO
Discount Schedule	PC22
Nbr. of units in pkg.	1
Package weight(Lbs)	2.2000000000000002
Returnability	N
Country of origin	FR

Offer Sustainability

Sustainable offer status	Not Green Premium product
RoHS (date code: YYWW)	Compliant - since 0849 - Schneider Electric declaration of conformity Schneider Electric declaration of conformity
REACH	Reference not containing SVHC above the threshold Reference not containing SVHC above the threshold
Product end of life instructions	Need no specific recycling operations

Contractual warranty

Warranty period	18 months
-----------------	-----------

Standard and Extendable Racks for Modules Mounting

Dimensions of Modules and Racks

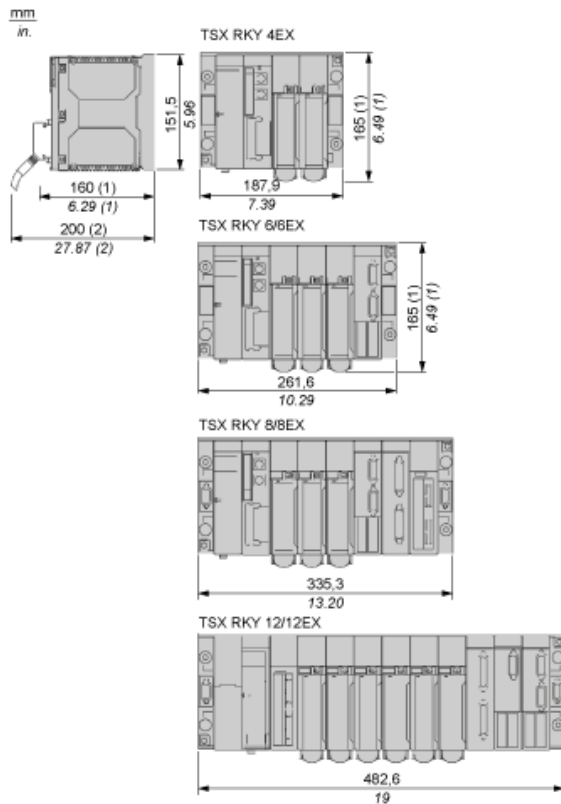

(1) With screw terminal block modules.

(2) Maximum depth for all types of modules and their associated connectors.

15-pin SUB-D Connectors of the Measurement and Counting Module

Pinout Configuration

Standard 15-pin SUB-D connector for connecting the counting sensor to channels 0, 1, 2 or 3

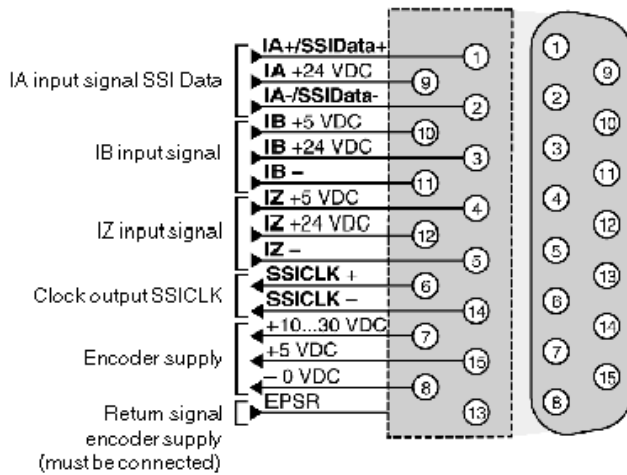

5 Vdc signal	Pins
+ IA input	1
- IA input	2
+ IB input	10
- IB input	11
+ IZ input	4
- IZ input	5
Encoder power supply:	
+5 Vdc	15
-0 Vdc	8
Encoder power supply feedback	13
10...30 Vdc signals	Pins
+ IA input	9
- IA input	2
+ IB input	3
- IB input	11
+ IZ input	12
- IZ input	5
Encoder power supply:	
+10...30 Vdc	7
-0 Vdc	8
Encoder power supply feedback	13

Serial signals (absolute encoder with serial or parallel outputs, using a TELEFAST ABE7CPA11 adapter)	Pins
+ SSI Data	1
- SSI Data	2
+ SSI CLK input	6
- SSI CLK input	14
Encoder power supply:	
+5 Vdc	15
-0 Vdc	8
Encoder power supply feedback	13

20-pin HE10 Connector of the Measurement and Counting Module

Wiring Diagram

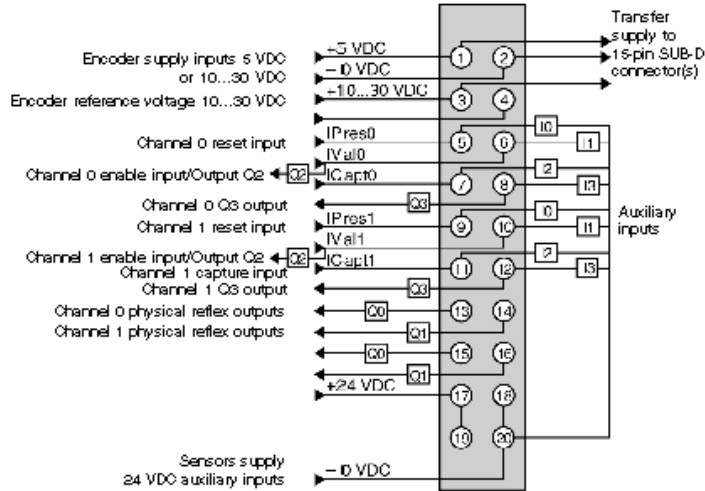

24 Vdc signals	Pins
Channel 0 auxiliary input:	
Preset IPres0	5
Confirmation IVal0/Output Q2	6
Capture ICapt0	7
Output Q3	8
Channel 1 auxiliary input:	
Preset IPres1	9
Confirmation IVal1/Output Q2	10
Capture ICapt1	11
Output Q3	12
Channel 0 reflex output:	
Output Q0	13
Output Q1	14
Channel 1 reflex output:	
Output Q0	15
Output Q1	16
Power Supplies	
Encoder power supply:	
+5 Vdc	1
- 0 Vdc	2
+10...30 Vdc	3
Encoder reference voltage +10...30 Vdc	4

Power Supplies	Pins
Sensor power supply:	
+24 Vdc	17 or 19
-0 Vdc	18 or 20