

# Technical Information

## Prosonic S FMU90

### Ultrasonic measurement

A universal device for level/flow measurement and pump control

### Transmitter for up to 2 sensors FDU90/91/91F/92/93/95



#### Field of application

Level measurement of fluids and bulk materials with 1 or 2 sensors for measuring of up to 45 m (148 ft) and level limit detection. Pump control, rake control and as option: additional pump control function.

- Calculations: average, difference, sum
- Application flow: Flow measurement in open channels and weirs with 1 or 2 sensors
- Flow measurement with back water or sludge detection
- Up to 3 totalizers and 3 counters
- Counting or time pulse output for control of external units
- Transmitter available with field housing or top hat rail housing for control cabinet instrumentation





#### Benefits



- Simple, menu-guided operation with 6-line plain text display, 15 languages selectable
- Envelope curves on the display for quick and simple diagnosis
- Easy operation, diagnosis and measuring point documentation with the supplied "FieldCare" operating program
- Time-of-flight correction via integrated or external temperature sensors
- Linearisation (up to 32 points, freely configurable) for the most common flumes and weirs pre-programmed and selectable
- Online calculation of the flume-/weir-flows via integrated flow curves

# Table of Contents

<b>Safety symbols</b> .....	<b>3</b>	Ingress protection .....	22
<b>Function and system design</b> .....	<b>4</b>	Electromagnetic compatibility (EMC) .....	22
Measuring principle .....	4	<b>Mechanical construction</b> .....	<b>22</b>
Blocking distance .....	4	Housing versions .....	22
Time-of-flight correction .....	4	Dimensions of the field housing .....	22
Interference echo suppression .....	4	Dimensions of the DIN-rail housing .....	23
Pump control .....	4	Dimensions of the separate display and operating module ..	24
Linearization .....	5	Weight .....	24
Special functions .....	5	Materials .....	25
Datalog functions .....	5	<b>Operability</b> .....	<b>25</b>
Application examples for level measurements .....	6	Display and operating module .....	25
Application examples for flow measurements .....	7	Operating menu .....	26
System integration HART .....	8	Basic setup .....	26
System integration PROFIBUS DP .....	8	Locking of the instrument .....	26
<b>Input</b> .....	<b>9</b>	<b>Certificates and Approvals</b> .....	<b>27</b>
Sensor inputs .....	9	CE mark .....	27
External limit switches (option) .....	9	Ex approval .....	27
External temperature sensor .....	9	External standards and guidelines .....	27
<b>Output</b> .....	<b>10</b>	<b>Ordering information</b> .....	<b>28</b>
Analog outputs .....	10	Product structure .....	28
Relay outputs .....	10	Scope of delivery .....	29
PROFIBUS DP interface .....	11	<b>Accessories</b> .....	<b>29</b>
<b>Power supply</b> .....	<b>11</b>	Commubox FXA195 HART .....	29
Supply voltage / Power consumption / Current consumption ..	11	Commubox FXA291 .....	29
Galvanic isolation .....	11	Protection cover for the field housing .....	29
Fuse .....	11	Mounting plate for the field housing .....	29
<b>Electrical connection</b> .....	<b>12</b>	Mounting bracket .....	30
Terminal compartment of the field housing .....	12	Adaption plate for remote display .....	30
Cable entries of the field housing .....	12	Overvoltage protection HAW562 .....	31
Terminal compartment of the DIN-rail housing .....	12	Temperature sensor FMT131 .....	34
Terminal assignment .....	14	<b>Documentation</b> .....	<b>35</b>
Connection of the sensors FDU9x .....	17	Technical Information .....	35
Synchronization line .....	18	Operating instructions	
Connection of the separate display and operating module ..	18	(for transmitter FMU90) .....	35
Connection of external switches		Description of Instrument Functions .....	35
(for FMU90-*****B***) .....	19	Safety Instructions .....	35
Connection of a temperature sensor .....	19		
<b>Performance characteristics</b> .....	<b>21</b>		
Reference operating conditions .....	21		
Maximum measuring error .....	21		
Typical measuring error <sup>9)</sup> .....	21		
Measured value resolution .....	21		
Measuring frequency .....	21		
Influence of the vapor pressure .....	21		
<b>Environment</b> .....	<b>21</b>		
Ambient temperature .....	21		
Storage temperature .....	21		
Climate class .....	21		
Vibration resistance .....	21		

## Safety symbols

Symbol	Meaning
 <small>A0011189-DE</small>	<p><b>DANGER!</b></p> <p>This symbol alerts you to a dangerous situation. Failure to avoid this situation will result in serious or fatal injury.</p>
 <small>A0011190-DE</small>	<p><b>WARNING!</b></p> <p>This symbol alerts you to a dangerous situation. Failure to avoid this situation can result in serious or fatal injury.</p>
 <small>A0011191-DE</small>	<p><b>CAUTION!</b></p> <p>This symbol alerts you to a dangerous situation. Failure to avoid this situation can result in minor or medium injury.</p>
 <small>A0011192-DE</small>	<p><b>NOTICE!</b></p> <p>This symbol contains information on procedures and other facts which do not result in personal injury.</p>

Explosion protection	Meaning
	<p><b>Device certified for use in explosion hazardous area</b></p> <p>If the device has this symbol embossed on its name plate it can be installed in an explosion hazardous area</p>
	<p><b>Explosion hazardous area</b></p> <p>Symbol used in drawings to indicate explosion hazardous areas. Devices located in and wiring entering areas with the designation "explosion hazardous areas" must conform with the stated type of protection.</p>
	<p><b>Safe area (non-explosion hazardous area)</b></p> <p>Symbol used in drawings to indicate, if necessary, non-explosion hazardous areas. Devices located in safe areas still require a certificate if their outputs run into explosion hazardous areas</p>

## Function and system design

### Measuring principle

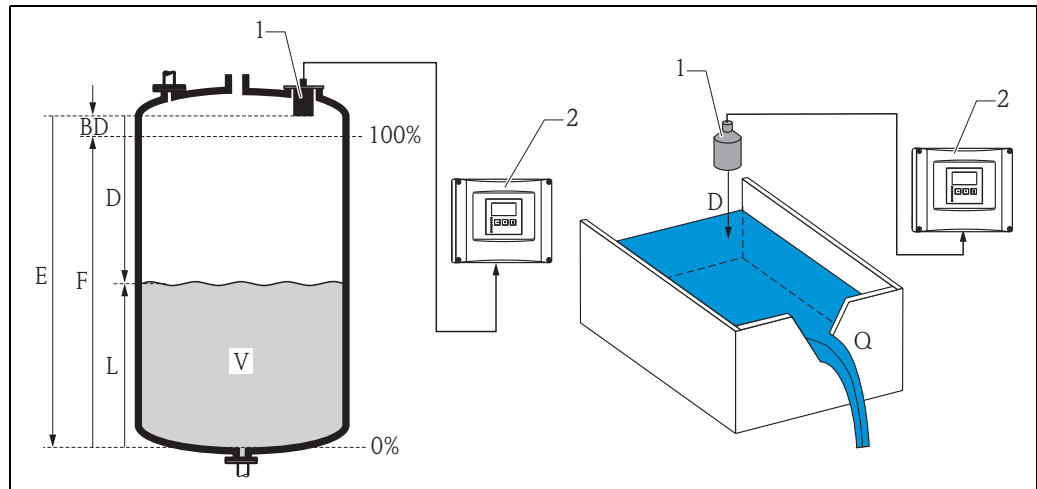

1 FDU9x

2 Prosonic S FMU90

**BD:** blocking distance, **D:** distance from sensor membrane to fluid surface, **E:** empty distance **F:** span (full distance), **L:** level, **V:** volume (or mass), **Q:** flow

L00-FMU90xxx-15-00-08-xx-900

The sensor transmits ultrasonic pulses in the direction of the product surface. There, they are reflected back and received by the sensor. The transmitter Prosonic S measures the time  $t$  between pulse transmission and reception. From  $t$  (and the velocity of sound  $c$ ) it calculates the distance  $D$  from the sensor membrane to the product surface:

$$D = c \cdot t / 2$$

From  $D$  results the desired measuring value:

- Level  $L$
- Volume  $V$
- Flow  $Q$  across measuring weirs or open channels

### Blocking distance

The span  $F$  may not extend into the blocking distance  $BD$ . Level echoes within the blocking distance range can not be evaluated due to the transient characteristics of the sensor. The blocking distances of the individual sensors are given in the following documents:

The blocking distances of the individual sensors are given in the following documents:

- TI00396F for the sensors FDU90/91/91F/92/93/95<sup>1)</sup>

### Time-of-flight correction

In order to compensate for temperature dependent time-of-flight changes, a temperature sensor (NTC) is integrated in the ultrasonic sensors.

Optionally, the Prosonic S FMU90 has an input for an external temperature sensor (FMU90-\*\*\*\*\*B\*\*\*). The following sensor can be connected:

- Pt100
- FMT131 from Endress+Hauser

The external sensor must be used for the heated version of the ultrasonic sensors FDU90 and FDU91.

### Interference echo suppression

The interference echo suppression feature of the Prosonic S ensures that interference echoes (e.g. from edges, welded joints and installations) are not interpreted as a level echo.

### Pump control

Individually configurable for each pump:

- Pump switching delay, e.g. to prevent overload of the power supply system
- Backlash time and backlash interval, e.g. for complete draining of shafts or channels
- Crust reduction at pump shaft walls by fine adjustment of the switch point

1) The sensors FDU80/80F/81/81F/82/83/84/85/86/96 are not available anymore.  
Use the serial number of your device to access the documentation for your device via [www.endress.com](http://www.endress.com).

**Linearization****Pre-programmed linearization curves***Types of vessels*

- Horizontal, cylindrical tank
- Spherical tank
- Tank with pyramidal bottom
- Tank with conical bottom
- Tank with flat, inclined bottom

*Flow curves for flumes and weirs<sup>2)</sup>*

- Khafagi-Venturi flume
- ISO-Venturi flume
- BST<sup>3)</sup>-Venturi flume
- Parshall flume
- Palmer-Bowlus flume
- Rectangular weir
- Rectangular constricted weir
- NFX<sup>4)</sup> rectangular weir
- NFX<sup>4)</sup> rectangular constricted weir
- Trapezoidal weir
- V-notch weir
- BST<sup>3)</sup> V-notch weir
- NFX<sup>4)</sup> V-notch weir

The pre-programmed linearization curves are calculated on-line.

**Linearization formula for flow measurements<sup>2</sup>**

$$Q = C (h^\alpha + \gamma h^\beta)$$

"h" is the upstream level. The parameters  $\alpha$ ,  $\beta$ ,  $\gamma$  and C can be freely programmed.

**Linearization table**

consisting of up to 32 linearization points; to be entered manually or half-automatically.

**Special functions**

- limit detection
- rake control
- alternating pump control or control according to pump rate (standard)
- option: additional pump control functions<sup>5)</sup>:
  - Alternation according to runtime or starts
  - pump feedback via the optional digital inputs; stand-by pump configurable
  - pump function test after resting time
  - storm function to prevent unnecessary pump running times
  - flush control for regular pump shaft cleaning
  - pump control according to tariff times via digital input
  - output of operating hours alarm or pump alarm
  - recording of pump data (operating hours, number of starts, last running time)
- totalising of the flow volume with (resettable) counters and (non-resettable) totalisers<sup>2</sup>
- triggering of a sampler by time or quantity pulses<sup>2</sup>
- low flow cut off<sup>2</sup>
- backwater detection in flumes<sup>2</sup>
- sludge detection in flumes<sup>2</sup>
- trend detection

**Datalog functions**

- Peak hold indicator of the min./max. levels or flows and the min./max. temperatures at the sensors
- Recording of the last 10 alarms
- Indication of the operating status
- Trend indication of the outputs on the on-site display
- Indication of the operating hours

2) for instrument versions with flow software (FMU90 - \*2\*\*\*\*\* or FMU90-\*4\*\*\*\*\*)

3) BST: British Standard

4) French standard NFX 10-311

5) for instruments with software for additional pump control (FMU90-\*3\*\*\*\*\* or FMU90-\*4\*\*\*\*\*)

Application examples for level measurements

Level measurement with limit detection and alarm output

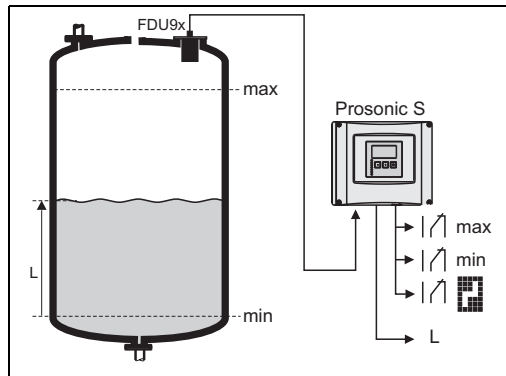

L00-FMU90xxx-15-00-00-xx-010

Order code e.g.: FMU90 - \*1\*\*\*131\*\*\*\*  
(1 input, 3 relays, 1 outputs)

Average level measurement

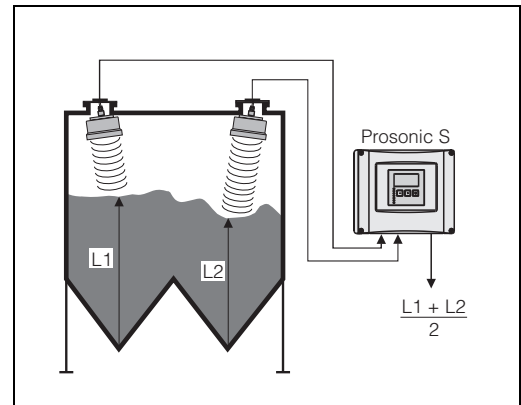

L00-FMU90xxx-15-00-00-xx-003

Order code e.g.: FMU90 - \*1\*\*\*212\*\*\*\*  
(2 inputs, 2 outputs)

Rake control (differential measurement)

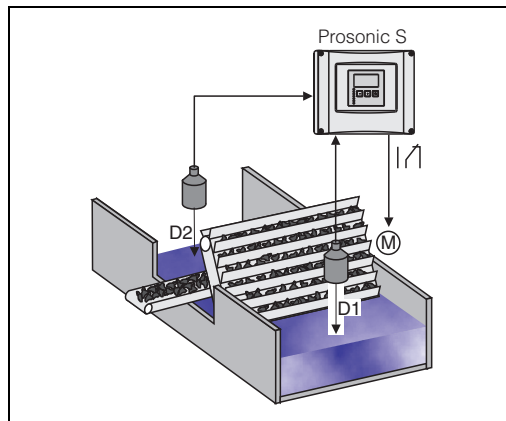

L00-FMU90xxx-15-00-00-xx-004

Order code e.g.: FMU90 - \*1\*\*\*212\*\*\*\*  
(2 inputs, 1 relay, 2 outputs)

Alternating pump control (up to 6 pumps)

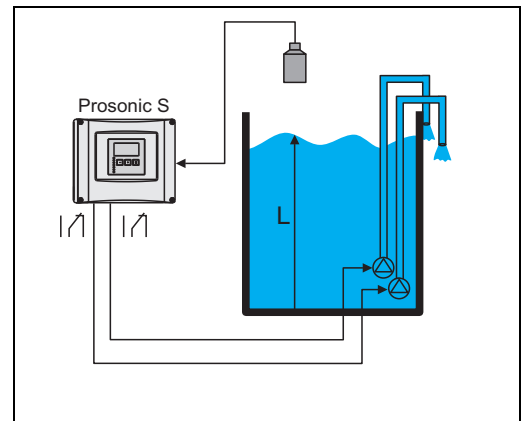

L00-FMU90xxx-15-00-00-xx-007

Order code e.g.: FMU90 - \*1\*\*\*131\*\*\*\*  
(1 input, 3 relays)

Conveyor belt

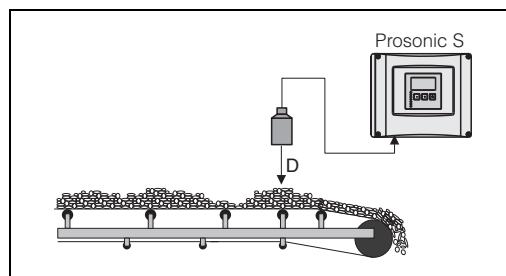

L00-FMU90xxx-15-00-00-xx-005

Order code e.g.: FMU90 - \*1\*\*\*111\*\*\*\*  
(1 input, 1 output)

**Application examples for flow measurements**

**Pulses for volume counter + time pulses (e.g. for sampler)**

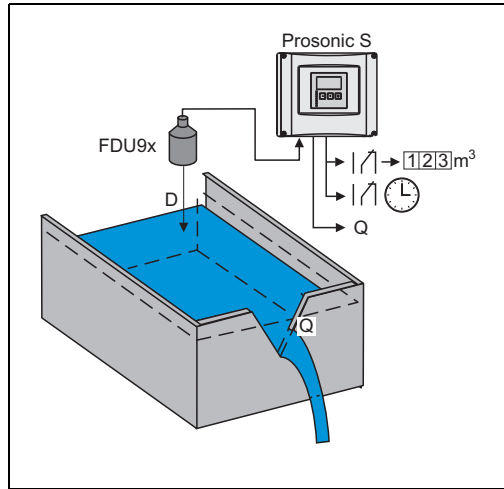

Order code e.g.: FMU90 - \*2\*\*\*131\*\*\*\*  
(1 input, 3 relays, 1 output)

**Flow measurement with backwater alarm or sludge detection**

If the ratio "downstream level:upstream level" rises above or falls below a critical value, an alarm will be generated.

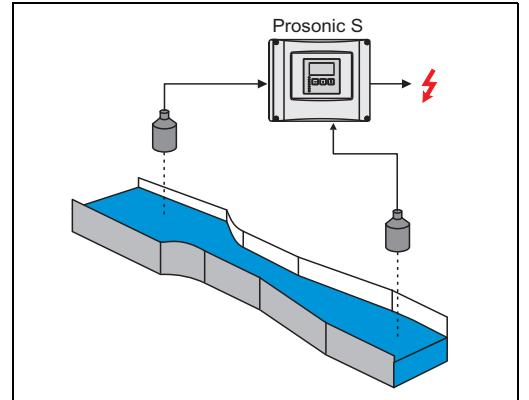

Order code e.g.: FMU90 - \*2\*\*\*212\*\*\*\*  
(2 inputs, 1 relay, 2 outputs)

**Stormwater overflow bassin**

Simultaneous measurement of level L and flow Q with 1 sensor.

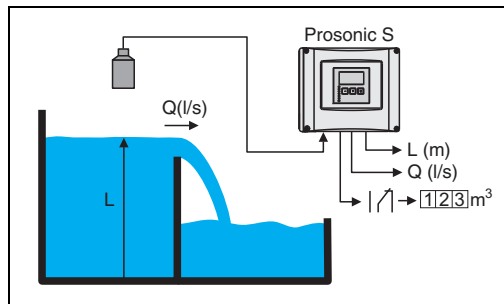

Order code e.g.: FMU90 - \*2\*\*\*112\*\*\*\*  
(1 input, 2 outputs)

**System integration HART**

**Operating options**

In the standard version a HART signal is superimposed onto the first output current. In order to use the HART communication, the circuit must contain a communication resistor of 250 Ω.

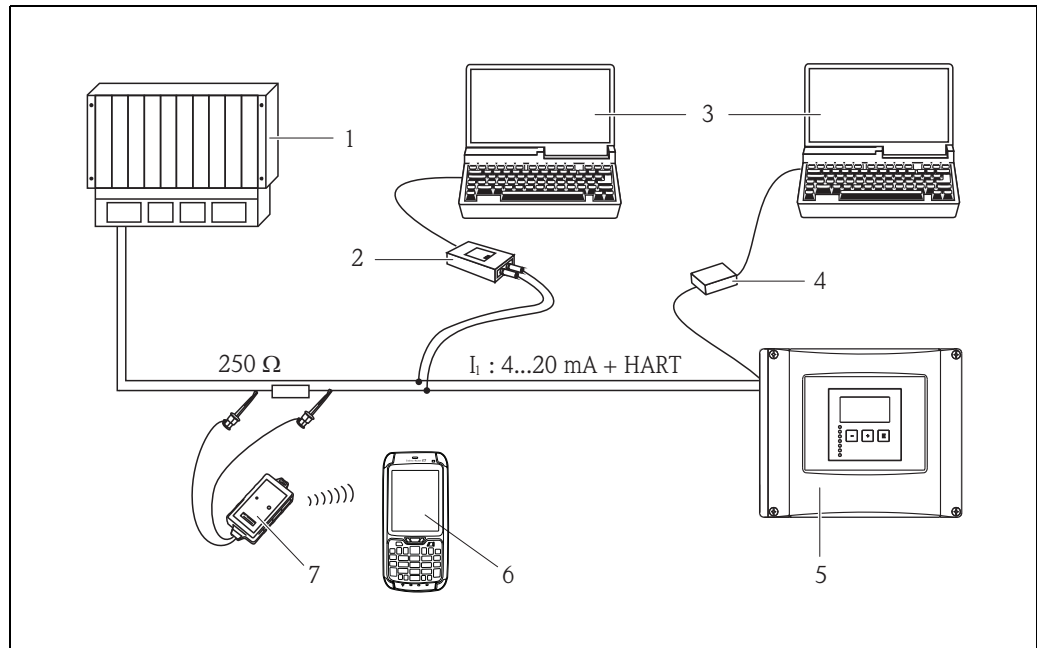

- 1 SPS, PLC, API
- 2 Commubox FXA195 (USB), HART-Protocol
- 3 FieldCare
- 4 Commubox FXA291 (service interface)
- 5 Operating and display module at the Prosonic S (if present)
- 6 Field Xpert SFX350/SFX370
- 7 VIATOR Bluetooth-Modem with connection cable

L00-FMU90xxxx-14-00-00-xx-020

**System integration PROFIBUS DP**

**Operating options**

- Via the display and operating module at the Prosonic S
- Via the service interface with the Commubox FXA291 and the operating program FieldCare
- Via PROFIBUS DP with PROFIBoard, PROFICard or PROFibus and the operating program FieldCare

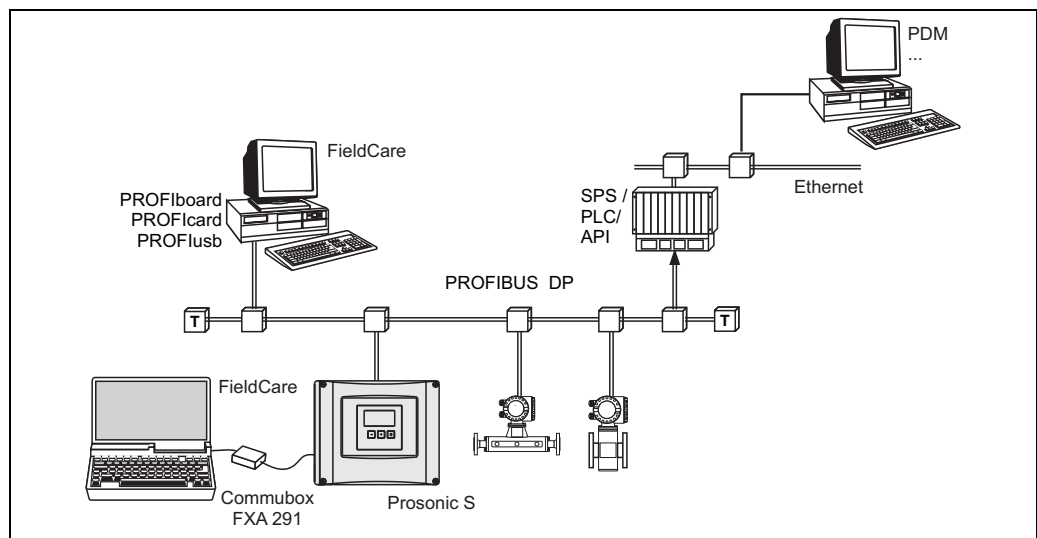

L00-FMU90xxxx-14-00-00-xx-021

## Input

### Sensor inputs

Depending on the instrument version, 1 or 2 of the sensors FDU90, FDU91, FDU91F, FDU92, FDU93, FDU95 can be connected. The Prosonic S identifies these sensors automatically.

Sensor	FDU90	FDU91 FDU91F	FDU92	FDU93	FDU95
Max. range <sup>1)</sup> in liquids	3 (9.8)	10 (33)	20 (66)	25 (82)	-
Max. range <sup>1)</sup> in solids	1.2 (3.9)	5 (16)	10 (33)	15 (49)	45 (148)

m (ft)

- 1) This table gives the maximum range. The range depends on the measuring conditions. For an estimation see Technical Information TI00396F, Chapter "Input".

In order to support existing installations, the following sensors can be connected as well.<sup>6)</sup> The type of sensor must be entered manually (except FDU96).

Sensor	FDU80 FDU80F	FDU81 FDU81F	FDU82	FDU83	FDU84	FDU85	FDU86	FDU96
Max. range <sup>1)</sup> in liquids	5 (16)	10 (33)	20 (66)	25 (82)	-	-	-	-
Max. range <sup>1)</sup> in solids	2 (6.6)	5 (16)	10 (33)	15 (49)	25 (82)	45 (148)	70 (230)	70 (230)

m (ft)

- 1) This table gives the maximum range. The range depends on the measuring conditions. For an estimation see Technical Information TI00189F, Chapter "Planning Recommendations".



The sensors FDU83, FDU84, FDU85 and FDU86 with an ATEX, FM or CSA certificate are not certified for connection to the FMU90 transmitter.

### External limit switches (option)

Optionally, the Prosonic S FMU90 has 4 inputs for external limit switches (FMU90-\*\*\*\*\*B\*\*\*).

#### Switching options

- External passive limit switch (NC/NO switch)
- 0: < 8 V; 1: > 16 V

#### Usage (examples)

- Pump feedback (for FMU90-\*3\*\*\*\*\*B\*\*\* and FMU90-\*4\*\*\*\*\*B\*\*\*)
- Pump tariff control (for FMU90-\*3\*\*\*\*\*B\*\*\* and FMU90-\*4\*\*\*\*\*B\*\*\*)
- Start/stop/reset of daily counters for flow measurements (for FMU90-\*2\*\*\*\*\*B\*\*\* and FMU90-\*4\*\*\*\*\*B\*\*\*)
- Min/max level detection, e.g. by Liquiphant

### External temperature sensor

Optionally, the Prosonic S FMU90 has an input for an external temperature sensor (FMU90-\*\*\*\*\*B\*\*\*).

#### Connectable sensors

- Pt100 (3-wire or 4-wire connection)  
A Pt100 with 2-wire connection may not be used due to its insufficient accuracy.
- FMT131 (from Endress+Hauser) → 29, "Accessories"

#### Usage (example)

- Time-of-flight correction for a heated sensor (FDU90-\*\*\*B\*, FDU91-\*\*\*B\*).

6) The sensors FDU80/80F/81/81F/82/83/84/85/86/96 are not available anymore.  
Use the serial number of your device to access the documentation for your device via [www.endress.com](http://www.endress.com).

## Output

### Analog outputs

Number	1 or 2, depending on instrument version
Output signal	Active current output output values configurable at the instrument: <ul style="list-style-type: none"> <li>▪ 4 to 20 mA with HART<sup>1)</sup></li> <li>▪ 0 to 20 mA without HART</li> </ul>
Signal on alarm	<ul style="list-style-type: none"> <li>▪ For setting 4 to 20 mA, selectable: <ul style="list-style-type: none"> <li>- MIN: -10 % (3,6 mA)</li> <li>- MAX: 110 % (22 mA)</li> <li>- HOLD (last current value is held)</li> <li>- User specific</li> </ul> </li> <li>▪ For setting 0 to 20 mA: <ul style="list-style-type: none"> <li>- MIN: 110 % (21,6 mA)</li> <li>- HOLD (last current value is held)</li> <li>- User specific</li> </ul> </li> </ul>
Output damping	Freely selectable, 0 to 1000 s
Load	Max. 600 $\Omega$ , influence negligible
Max. ripple	$U_{SS} = 200$ mV at 47 to 125 Hz (measured at 500 $\Omega$ )
Max. noise	$U_{eff} = 2,2$ mV at 500 Hz to 10 kHz (measured at 500 $\Omega$ )

- 1) The HART signal is assigned to the first analog output. The second analog output does not carry a HART signal.

### Relay outputs

Number	1, 3 or 6; depending on the instrument version
Type	Potential-free relay, SPDT, can be inverted
Assignable functions	<ul style="list-style-type: none"> <li>▪ Limit (inband, out-of-band, trend, level limit)</li> <li>▪ Counting pulse<sup>1</sup> for flow counting (max. frequency 2 Hz; pulse width adjustable)</li> <li>▪ Time pulse<sup>1</sup> (max. frequency 2 Hz; pulse width adjustable)</li> <li>▪ Alarm/diagnosis (e.g. indication of backwater<sup>1)</sup>, sludge<sup>1</sup>, echo loss etc.)</li> <li>▪ Pump control (alternating/fixed limit/pump rate)</li> <li>▪ For FMU90-*3***** and FMU90-*4*****): additional pump control (standby pump, storm function to avoid unnecessary run times of the pumps, pump function test, flush control to clean pump shafts, operating hours alarm, pump alarm)</li> <li>▪ Rake control (difference or relative measurement)</li> <li>▪ Fieldbus relay (to be switched directly from the PROFIBUS DP-bus)</li> </ul>
Switching power	<ul style="list-style-type: none"> <li>▪ DC voltage: 35 <math>V_{DC}</math>, 100 W</li> <li>▪ AC voltage: 4 A, 250 V, 1000 VA at <math>\cos\phi = 0,7</math></li> </ul>
State on error	Selectable: <ul style="list-style-type: none"> <li>▪ HOLD (last value is held)</li> <li>▪ Energized</li> <li>▪ Ee-energized</li> <li>▪ Present value is used</li> </ul>
Behaviour after power failure	Switch-on delay selectable
LEDs <sup>2)</sup>	A yellow LED on the front panel is allocated to each relay, which lights if the relay is energized. The LED of an alarm relay lights during normal operation. The LED for a pulse relay briefly flashes at every pulse.

- 1) For instrument versions with flow software (FMU90 - \*2\*\*\*\*\*)
- 2) For instrument versions with display and operating module

**PROFIBUS DP interface**

Profile	3.0
Transmittable values	<ul style="list-style-type: none"> <li>■ Main value (level or flow, depending on the instrument version)</li> <li>■ Distances</li> <li>■ Counters</li> <li>■ Temperatures</li> <li>■ Average/difference/sum</li> <li>■ Relay states</li> <li>■ Rake control</li> <li>■ Pump control</li> </ul>
Function blocks	<ul style="list-style-type: none"> <li>■ 10 Analog Input Blocks (AI)</li> <li>■ 10 Digital Input Blocks (DI)</li> <li>■ 10 Digital Output Blocks (DO)</li> </ul>
Supported baud rates	<ul style="list-style-type: none"> <li>■ 9.6 kbaud</li> <li>■ 19.2 kbaud</li> <li>■ 45,45 kbaud</li> <li>■ 93.75 kbaud</li> <li>■ 187.5 kbaud</li> <li>■ 500 kbaud</li> <li>■ 1.5 Mbaud</li> <li>■ 3 Mbaud</li> <li>■ 6 Mbaud</li> <li>■ 12 Mbaud</li> </ul>
Service Access Points (SAPs)	1
ID number 1540 (hex)	1540 (hex) = 5440 (dec)
GSD file	EH3x1540.gsd
Addressing	Via dip switches at the instrument or via software (e.g. FieldCare). Default address: 126 per software
Termination	Can be activated/deactivated in the instrument.
Locking	The device can be locked by hardware or software.

## Power supply

**Supply voltage /  
Power consumption /  
Current consumption**

Instrument version	Supply voltage	Power consumption	Current consumption
AC voltage (FMU90 - ****A****)	90 to 253 V <sub>AC</sub> (50/60 Hz)	Max. 23 VA	Max. 100 mA at 230 V <sub>AC</sub>
DC voltage (FMU90 - ****B****)	10,5 to 32 V <sub>DC</sub>	Max. 14 W (typically 8 W)	Max. 580 mA at 24 V <sub>DC</sub>

**Galvanic isolation**

The following terminals are galvanically isolated from each other:

- Auxiliary energy
- Sensor inputs
- Analog output 1
- Analog output 2
- Relay outputs
- Bus connection (PROFIBUS DP)

**Fuse**

- 2 A T /DC
- 400 mA T /AC

Accessible in the terminal compartment

## Electrical connection

### Terminal compartment of the field housing

The field housing has a separate terminal compartment. It can be opened after loosening the 4 screws of the lid.

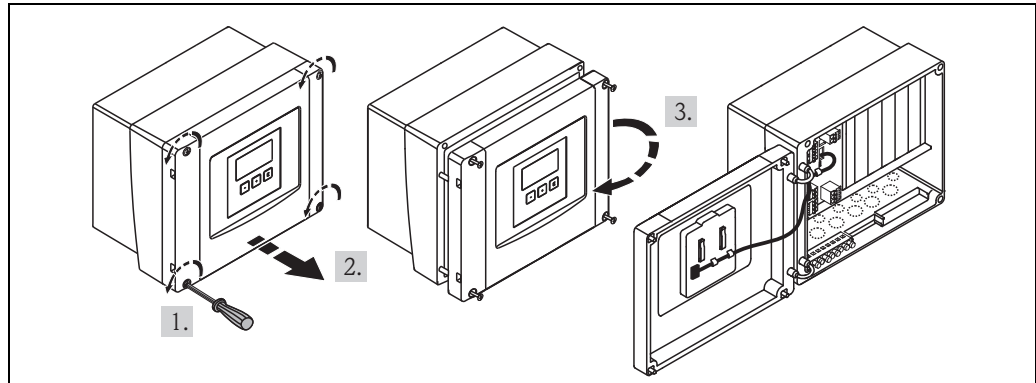

L00-FMU90xxx-04-00-00-xx-002

For easier wiring, the lid can be completely removed by unplugging the display plug and loosening the hinges:

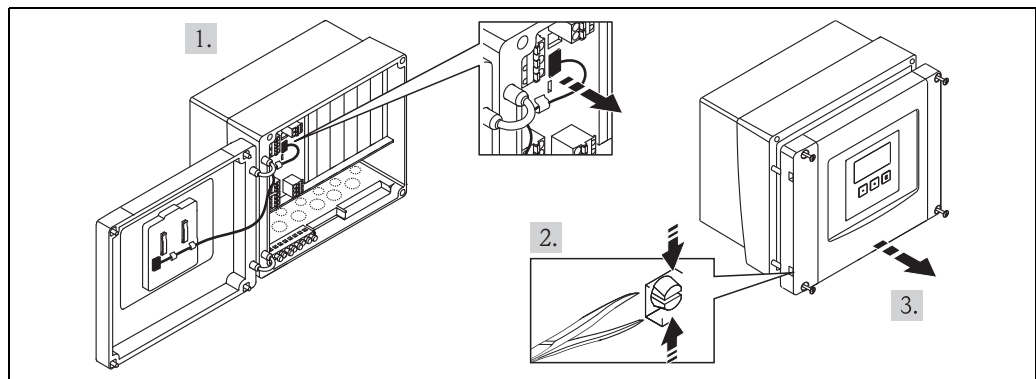

L00-FMU90Kxx-04-00-00-xx-009

### Cable entries of the field housing

On the bottom of the housing the following openings for cable entries are pre-stamped:

- M20x1.5 (10 openings)
- M16x1.5 (5 openings)
- M25x1.5 (1 opening)

A suitable cutting device must be used for cutting out the openings.

### Terminal compartment of the DIN-rail housing

#### Single instrument

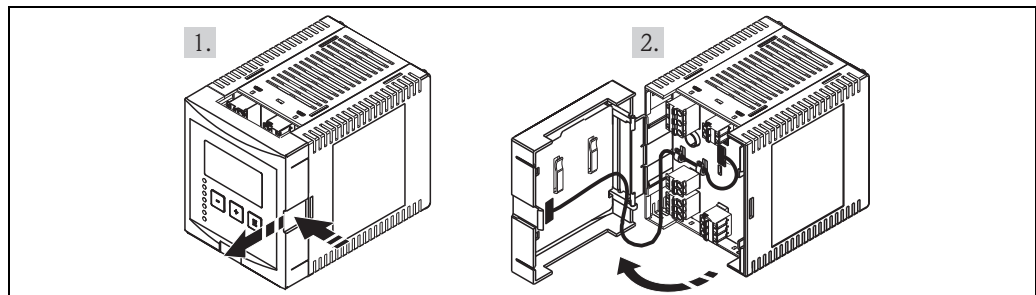

L00-FMU90xxx-04-00-00-xx-003

The catch can be unlocked by slightly pressing onto the clip. Then, the cover of the terminal compartment can be opened.

## Several instruments mounted side by side

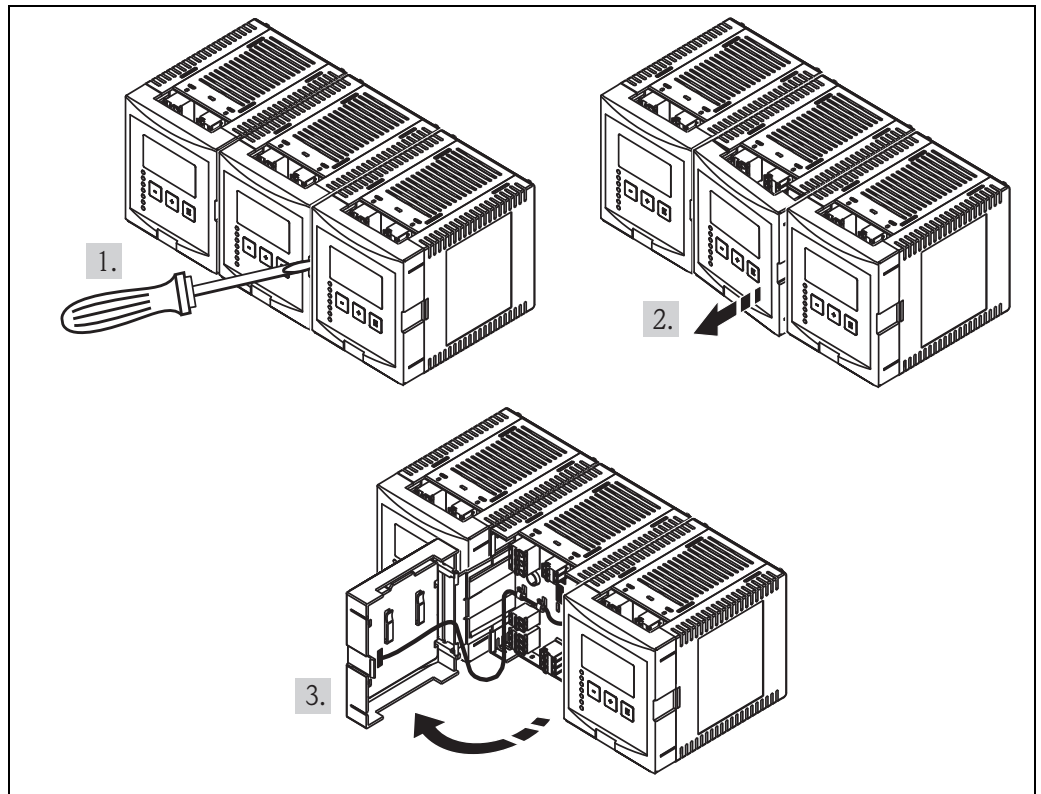

L00-FMU90xxx-04-00-00-xx-012

Open the catch of the cover (e.g. by a screwdriver).

Pull the cover out by approx. 20 mm (0.79 in).

The cover can now be opened.

- The cables can be inserted into the housing from above or from below.
- The pictures show the smallest housing version but are valid for the larger versions as well.
- If the instruments are mounted next to each other and if the sensor cables run in parallel, the synchronization terminals (39 and 40) must be interconnected (see sections → [14 "Terminal assignment"](#) and → [18 "Synchronization line"](#)).

**Terminal assignment**

Pluggable spring-force terminals for connection of the cables are supplied in the terminal compartment. Rigid conductors or flexible conductors with cable sleeve can directly be inserted and are contacted automatically.

Feature	Value
Conductor cross section	0,2 mm <sup>2</sup> to 2,5 mm <sup>2</sup> (26 to 14 AWG)
Cable and sleeve cross section	0,25 mm <sup>2</sup> to 2,5 mm <sup>2</sup> (24 to 14 AWG)
Min. stripping length	10 mm (0.39 in)

The terminal configuration depends on the instrument version ordered. There is a basic terminal area, which is present in every instrument version. Additional optional terminal areas are only present if the respective option has been selected in the product structure.

Terminal area	Present for the following instrument versions
Basic area	A For all versions
Optional areas	B For instrument versions with 2 sensor inputs and/or 2 analog outputs (FMU90 - *****2***** and/or FMU90 - *****2*****)
	C For instrument versions with 3 or 6 relays (FMU90 - *****3***** oder FMU90 - *****6*****)
	D For instruments with external switch inputs and external temperature input (FMU90 - *****B*****)
	E For instrument versions with PROFIBUS DP interface (FMU90 - *****3*****)

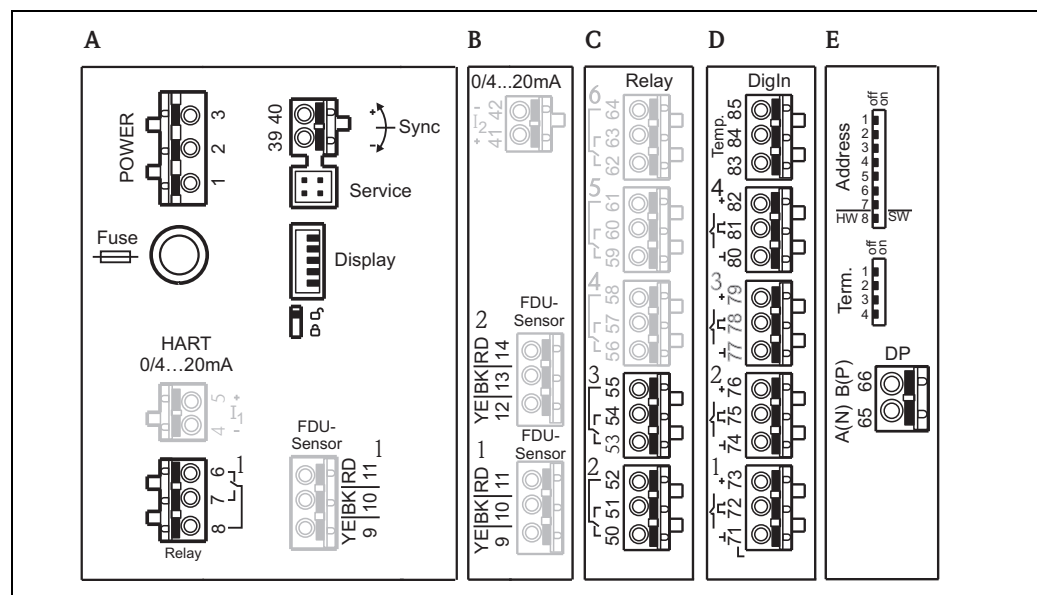

Terminals of the Prosonic S (the terminals depicted in grey are not present in every instrument version)

- A Basic terminal area
- B – E Optional terminal areas (present if the respective option has been selected in the product structure)

**i** The depicted switching states of the relays refer to the de-energized state.

Terminals	Meaning	Terminal area	Remarks
<b>Auxiliary energy</b>			
1, 2	<ul style="list-style-type: none"> <li>▪ L (für AC version)</li> <li>▪ L+ (for DC version)</li> </ul>	A	Depending on instrument version: <ul style="list-style-type: none"> <li>▪ 90 to 253 V<sub>AC</sub></li> <li>▪ 10,5 to 32 V<sub>DC</sub></li> </ul>
2	<ul style="list-style-type: none"> <li>▪ N (for AC version)</li> <li>▪ L- (for DC version)</li> </ul>	A	
3	Potential equalization	A	
Fuse		A	Depending on instrument version: <ul style="list-style-type: none"> <li>▪ 400 mA T (for AC)</li> <li>▪ 2 A T (for DC)</li> </ul>
<b>Analog outputs (not available for PROFIBUS DP instruments)</b>			
4, 5	Analog output 1; 4 to 20 mA with HART/ 0 to 20 mA w/o HART	A	<b>Not present for the PROFIBUS DP version</b>
41, 42	Analog output 2 (optional); 4 to 20 mA/ 0 to 20 mA	B	Only for the version with two analog outputs; no HART signal at this output
<b>Relay outputs</b>			
6, 7, 8	Relay 1	A	
50, 51, 52	Relay 2 (optional)	C	Only for the versions with 3 or 6 relays
53, 54, 55	Relay 3 (optional)	C	Only for the versions with 3 or 6 relays
56, 57, 58	Relay 4 (optional)	C	Only for the version with 6 relays
59, 60, 61	Relay 5 (optional)	C	Only for the version with 6 relays
62, 63, 64	Relay 6 (optional)	C	Only for the version with 6 relays
<b>Bus communication (only available for PROFIBUS DP instruments)</b>			
65	PROFIBUS A (RxT/TxD - N)	D	Only for the PROFIBUS DP version
66	PROFIBUS B (RxT/TxD - P)	D	
<b>Synchronization</b>			
39, 40	Synchronization	A	See section 4.6, "Synchronization line"
<b>Level inputs</b>			
9 (YE), 10 (BK), 11 (RD)	Sensor 1 (FDU8x/9x) YE: yellow strand BK: black strand RD: red strand		<ul style="list-style-type: none"> <li>▪ A: for versions with 1 sensor input</li> <li>▪ B: for versions with 2 sensor inputs<sup>1)</sup></li> </ul>
12 (YE), 13 (BK), 14 (RD)	Sensor 2 (FDU8x/9x) (optional) YE: yellow strand BK: black strand RD: red strand	B	Only for the version with 2 sensor inputs
<b>External switch inputs</b>			
71, 72, 73	External switch input 1	D	0: < 8 V or 72 and 73 interconnected 1: > 16 V or 72 and 73 not interconnected
74, 75, 76	External switch input 2	D	0: < 8 V or 75 and 76 interconnected 1: > 16 V or 75 and 76 not interconnected
77, 78, 79	External switch input 3	D	0: < 8 V or 78 and 79 interconnected 1: > 16 V or 78 and 79 not interconnected
80, 81, 82	External switch input 4	D	0: < 8 V or 81 and 82 interconnected 1: > 16 V or 81 and 82 not interconnected

Terminals	Meaning	Terminal area	Remarks
<b>Temperature input</b>			
83, 84, 85	Temperature input: <ul style="list-style-type: none"> <li>■ PT100</li> <li>■ FMT131 (Endress+Hauser)</li> </ul>	D	See section "Connection of a temperature sensor"

1) In this case, terminals 9/10/11 are not present on terminal area A.

**⚠ CAUTION**

**Limitation of electrical safety.**

- ▶ When using the public supply mains, an easily accessible power switch must be installed in the proximity of the device. The power switch must be marked as a disconnect for the device (IEC/EN 61010).



In order to avoid interference, do not route the sensor cables parallel to high-voltage or electric power lines and not close to frequency converters.

**Additional elements on the terminal areas**

Designation	Meaning/Remarks
Fuse	Fuse: 2 A T /DC or 400 mA T/AC
Display	Connection of the display or the remote display and operating module
Service	Service interface for connection of a PC/Notebook via Commubox FXA291
	Locking switch
Term.	Bus termination (only applicable for instruments with PROFIBUS interface)
Address	Bus address (only applicable for instruments with PROFIBUS interface)

**Connection of the sensors  
FDU9x**

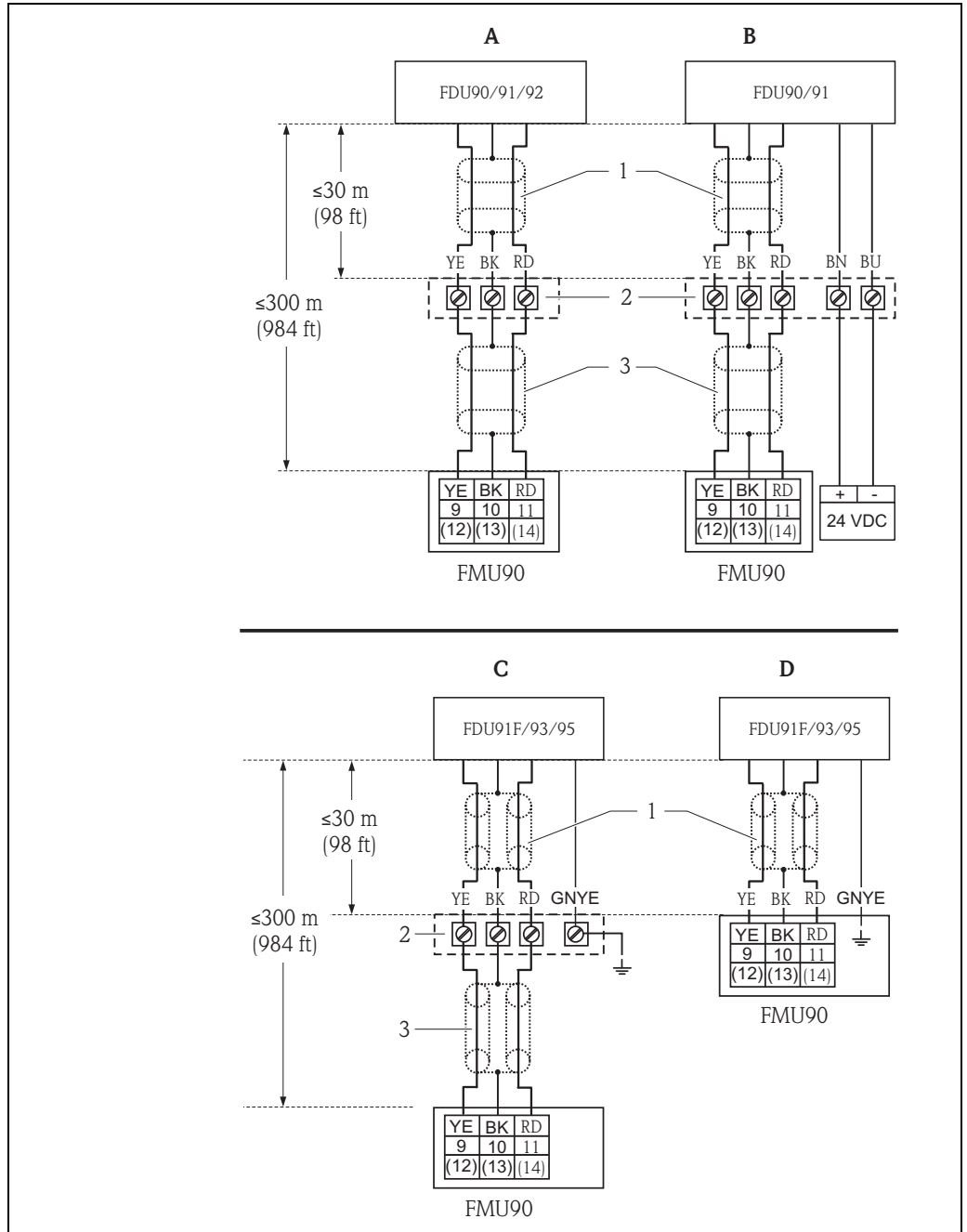

L00-FDU9xxx-04-00-00-xx-002

- A Without sensor heater
- B With sensor heater
- C Grounding at the terminal box
- D Grounding at the transmitter FMU90

- 1 Screen of the sensor cable
- 2 Terminal box
- 3 Screen of the extension cable

Colours of the strands: YE = yellow; BK = black; RD = red; BU = blue; BN = brown; GNYE = green-yellow

For details refer to Technical Information TI00396F<sup>7)</sup>.

7) The sensors FDU80/80F/81/81F/82/83/84/85/86/96 are not available anymore.  
Use the serial number of your device to access the documentation for your device via [www.endress.com](http://www.endress.com).

## Synchronization line

- If wiring several Prosonic S (FMU90/FMU95) which are mounted in a common cabinet and if the sensor cables run in parallel, the synchronization terminals (39 and 40) must be interconnected.
- Up to 20 instruments can be synchronized in this way.
- The synchronization prevents an evaluation unit from receiving a signal while a different evaluation unit is emitting a signal. This prevents pulses in the sensor cable of one sensor from influencing the received signal on the cable of a different sensor.
- If there are more than 20 instruments, groups must be formed, each containing a maximum of 20 instruments. For the instruments within each group, the sensor cables may run in parallel. The sensor cables of different groups must be separated from each other.
- Usual commercial screened cable can be used for synchronization
  - Max. length: 10 m (33 ft) between the individual instruments
  - cross section:  $2 \times (0.75 \text{ to } 2.5 \text{ mm}^2)$  (18 to 14 AWG)
  - for lengths up to 1 m (3.3 ft), an unscreened cable can be used; for lengths exceeding 1 m (3.3 ft), screening is required. The screen must be connected to ground
- Instruments of the Prosonic FMU86x family can be connected to the synchronization line as well. In this case a maximum of 10 instruments can be connected to each synchronisation line.

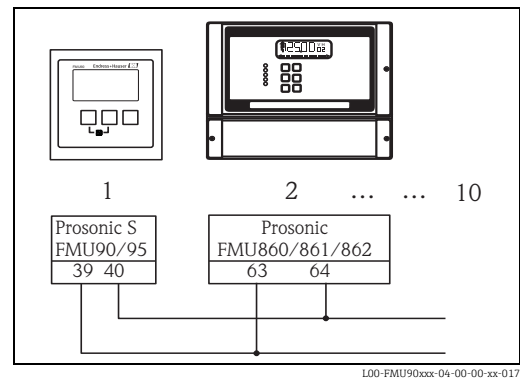
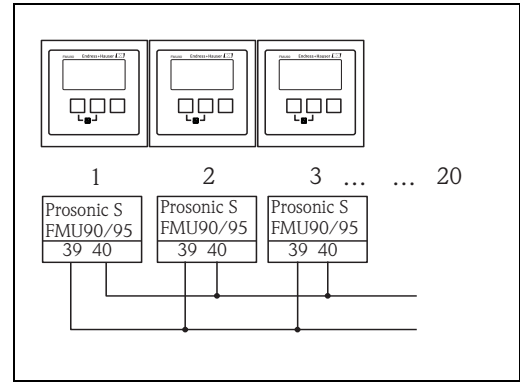

## Connection of the separate display and operating module

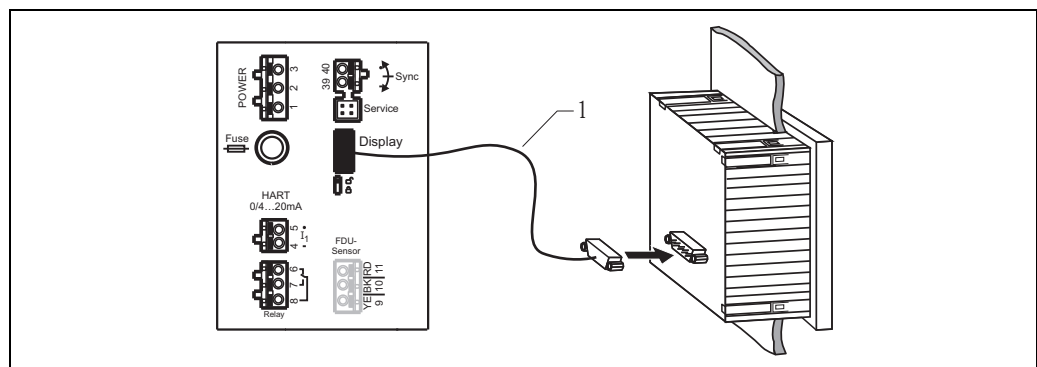

1 Connection of the display plug with the cable (3 m (9.8 ft))

For the version of the Prosonic S with a separate display for panel mounting, a pre-assembled connecting cable (3 m (9.8 ft)) is supplied. The cable must be connected to the display plug of the Prosonic S.

 Minimum diameter for cable bushing: 20 mm (0.79 in)

**Connection of external switches  
(for FMU90-\*\*\*\*\*B\*\*\*)**

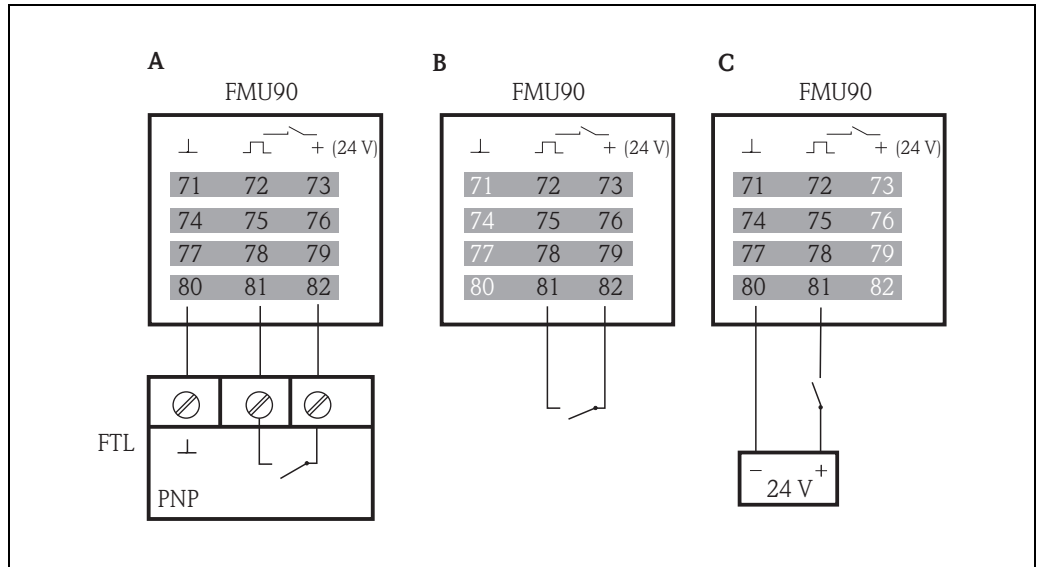

- A *Liquiphant*
- B *External switch*
- C *External switch with external supply voltage*

The maximum short-circuit current at 24 V is 20 mA.

**Connection of a temperature sensor**

The Prosonic S FMU90 transmitter has an optional input for an external temperature probe (in the product structure: feature 90 "Additional input", option B, → 28). The following probes can be connected:

- a FMT131 temperature probe from Endress+Hauser
  - a Pt100 temperature probe
- i** After connecting an external temperature sensor, the following is required:
1. The type of the connected sensor (Pt100 or FMT131) must be selected in "sensor management/ext. temp. sensor" in the "sensor type" parameter.
  2. The external temperature sensor must be assigned to an ultrasonic sensor in "sensor management/FDU sensor/US sensor N" in the "temp. measurement" parameter.

If the option "alarm" has been selected for the case of an error in external temperature sensor, this alarm is indicated by the alarm relay.

**FMT131 (Endress+Hauser) (connectable to FMU90-\*\*\*\*\*B\*\*\*)**

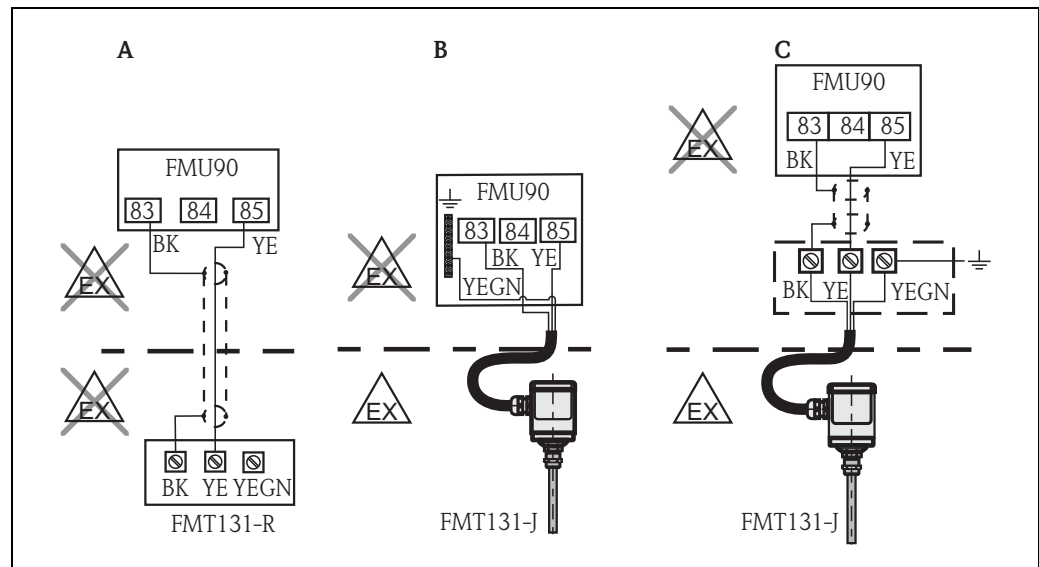

A Non-Ex area (FMT131-R) BK black  
 B Ex area (FMT131-j) with grounding in the FMU90 YE yellow  
 C Ex area (FMT131-j) with grounding at a terminal box YEGN yellow-green

**i** Further information: Operating Instructions for Temperature sensor FMT131, document number KA00019F.

**Pt100 (connectable to FMU90-\*\*\*\*\*B\*\*\*)**

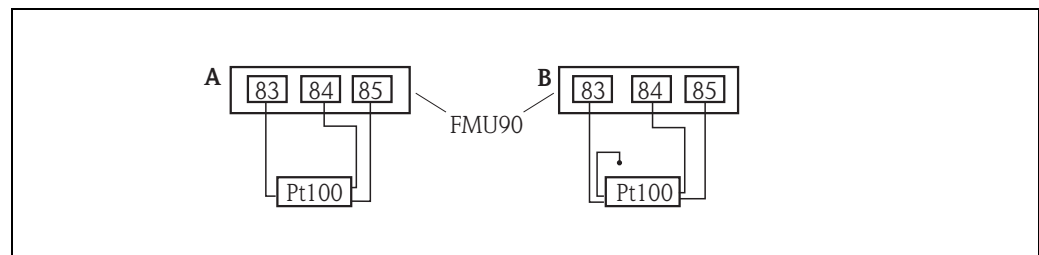

A Pt100 with 3-wire connection  
 B Pt100 with 4-wire connection (one connector remains unused)

**i** A Pt100 with 2-wire-connection may not be used due to its insufficient measuring accuracy.

**⚠ WARNING**

**Explosion hazard!**

**A Pt100 must not be connected in explosion hazardous areas.**

- ▶ In explosion hazardous areas, use an FMT131.

## Performance characteristics

<b>Reference operating conditions</b>	<ul style="list-style-type: none"> <li>■ Temperature = 24±5 °C (75±9 °F)</li> <li>■ Pressure = 960±100 mbar (14±1.45 psi)</li> <li>■ Relative humidity = 60±15 %</li> <li>■ Ideally reflecting surface, sensor vertically aligned (e.g. calm, plane liquid surface of 1 m<sup>2</sup> (10.76 ft<sup>2</sup>))</li> <li>■ No interference echoes within the signal beam</li> <li>■ Settings of the application parameters: <ul style="list-style-type: none"> <li>- Tank shape = flat ceiling</li> <li>- Medium property = liquid</li> <li>- Process condition = calm surface</li> </ul> </li> </ul>
<b>Maximum measuring error<sup>8) 9)</sup></b>	±0.2 % of the maximum span of the sensor
<b>Typical measuring error<sup>9)</sup></b>	Includes linearity, repeatability, and hysteresis Better than ±2 mm (0.08 in) + 0.17 % of the measured distance
<b>Measured value resolution</b>	1 mm (0.04 in) with FDU90/FDU91
<b>Measuring frequency</b>	Max. 3 Hz The exact value depends on the settings of the application parameters and the instrument version.
	 The maximum measuring frequency is obtained for "empty E" ≤ 2 m (≤ 6.6 ft) and "process condition" = "test: no filter".
<b>Influence of the vapor pressure</b>	The vapor pressure at 20 °C (68 °F) gives a hint on the accuracy of the ultrasonic level measurement. If the vapor pressure at 20 °C (68 °F) is below 50 mbar (1 psi), ultrasonic level measurement is possible with a very high accuracy. This is valid for water, aqueous solutions, water-solid-solutions, dilute acids (hydrochloric acid, sulfuric acid, ...), dilute bases (caustic soda, ...), oils, greases, slurries, pastes, ... High vapor pressures or outgassing media (ethanol, acetone, ammonia, ...) can influence the accuracy. If conditions like these are present, please contact Endress+Hauser: <a href="http://www.endress.com/contact">http://www.endress.com/contact</a>

## Environment

<b>Ambient temperature</b>	-40 to 60 °C (-40 to 140 °F) The functionality of the LC display becomes restricted at T <sub>U</sub> < -20 °C ( T <sub>U</sub> < -4 °F). If the device is operated outdoors in strong sunlight, a protective cover should be used (→  29).
<b>Storage temperature</b>	-40 to 60 °C (-40 to 140 °F)
<b>Climate class</b>	<ul style="list-style-type: none"> <li>■ <b>Field housing:</b> according to DIN EN 60721-3 4K2/4K5/4K6/4Z2/4Z5/4C3/4S4/4M2 (DIN 60721-3 4K2 corresponds to DIN 60654-1 D1)</li> <li>■ <b>Housing for DIN rail mounting:</b> according to DIN EN 60721-3 3K3/3Z2/3Z5/3B1/3C2/3S3/3M1 (DIN 60721-3 3K3 corresponds to DIN 60654-1 B2)</li> </ul>
<b>Vibration resistance</b>	<ul style="list-style-type: none"> <li>■ Housing for DIN rail: DIN EN 60068-2-64 / IEC 68-2-64; 20 to 2000 Hz; 0,5 (m/s<sup>2</sup>)<sup>2</sup>/Hz</li> <li>■ Field housing: DIN EN 60068-2-64 / IEC 68-2-64; 20 to 2000 Hz; 1,0 (m/s<sup>2</sup>)<sup>2</sup>/Hz</li> </ul>

8) according to EN 61298-2

9) with reference operating conditions

**Ingress protection**

- Field housing: IP66 / NEMA 4x
- Housing for DIN rail: IP20
- Separate display:
  - IP65 / NEMA 4 (front panel, if mounted in cabinet door)
  - IP20 (rear panel, if mounted in cabinet door)

**Electromagnetic compatibility (EMC)**

Electromagnetic compatibility according to all relevant requirements of the EN 61326- series and NAMUR recommendation EMC (NE21). For details see declaration of conformity.  
With respect to interference emission the devices meet the requirements of class A and are only provided for use in an "industrial environment"!

## Mechanical construction

**Housing versions**

- Field housing; optionally with integrated display and operating module
- Housing for top-hat rail mounting; optionally with integrated display and operating module
- Housing for top-hat rail mounting with separated display and operating module for cabinet door mounting

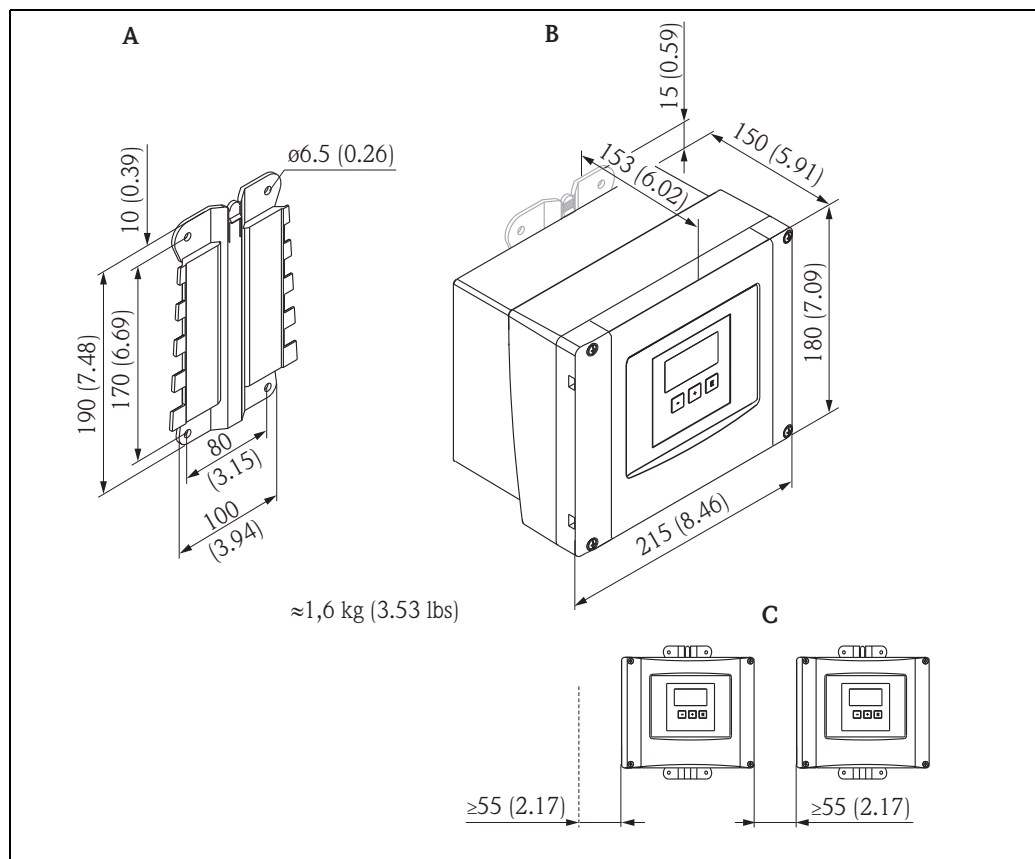
**Dimensions of the field housing**

Dimensions in mm (in)

- A Mounting help (supplied); can also be used as drilling template  
 B Field housing  
 C Minimum mounting distance

The dimensions of the field housing are the same for all instrument versions.  
To open the housing, a minimum mounting distance of 55 mm (2.17 in) is required on the left.



The mounting help must be mounted on a plane surface and must not become bent. Otherwise the mounting of the field housing may be difficult or impossible.

**Dimensions of the DIN-rail housing**

The dimensions of the DIN-rail housing depend on the instrument version. The version determines, which terminal areas the Prosonic S contains. The dimensions are influenced by the following features of the product structure:

- 60: Level Input
- 70: Switch Output
- 80: Output

In order to determine the dimensions of a specific version, perform the following steps (see the example → 24):

1. Using the product structure, determine the options of the features 60, 70 and 80 of the instrument version in question.

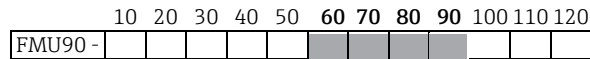

2. Using the following table, determine how many optional terminal areas this instrument version contains.

Feature and option of the product structure	Corresponds to the following terminal area	Present? yes = 1 no = 0
Feature 60; option 2 and/or feature 80, option 2	2 sensor inputs and/or 2 analog outputs	
Feature 70, option 3 or 6	3 or 6 relays	
Feature 80, option 3	PROFIBUS DP interface	
Feature 90, option B	Inputs for external switches and external temperature sensor	
Sum =		

3. The appropriate dimensions are given in the following diagram:

**Sum = 0  
(only basic terminal area)**

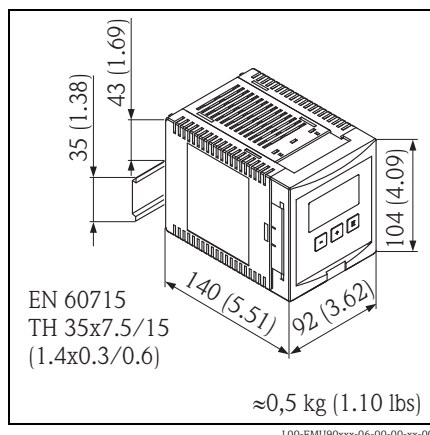

**Sum = 1, 2 or 3  
(1-3 optional terminal areas)**

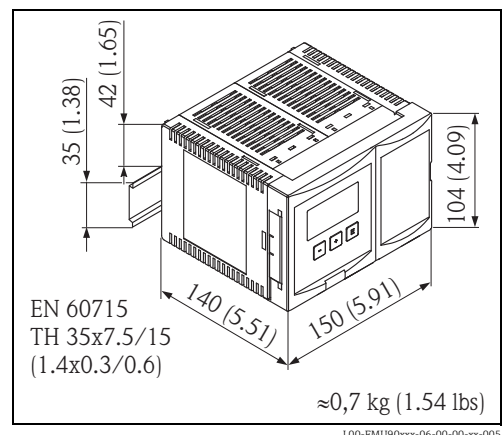

Dimensions in mm (in)

Sum = 4  
(4 optional terminal areas)

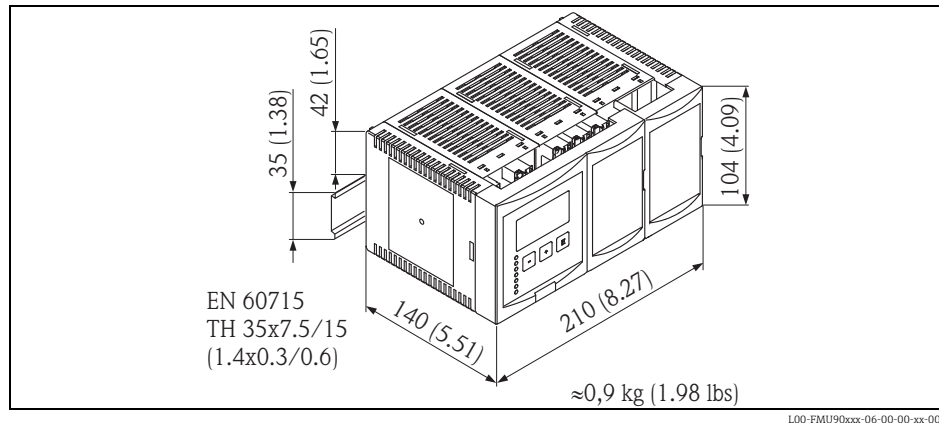

Dimensions in mm (in)

Example

		10	20	30	40	50	60	70	80	90	100	110	120
FMU90 -	R	1	2	A	A	2	3	2	A	A	1	A	

Feature and option of the product structure	Corresponds to the following terminal area	Present?
Feature 60; option 2 and/or Feature 80, option 2	2 sensor inputs and/or 2 analog outputs	1 (yes)
Feature 70, option 3 or 6	3 or 6 relays	1 (yes)
Feature 80, option 3	PROFIBUS DP interface	0 (no)
Feature 90, option B	Inputs for external switches and external temperature sensor	0 (no)
Sum =		2

Sum = 2  
=> 104 mm x 150 mm x 140 mm (4.09 x 5.91 x 5.51 in)

Dimensions of the separate display and operating module

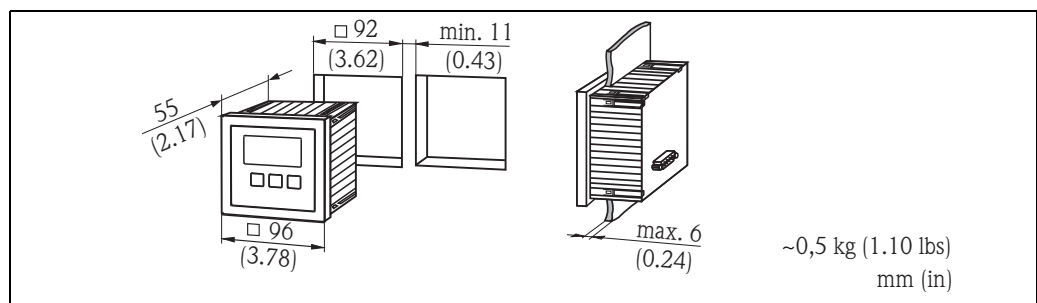

Weight

Housing version	Weight
Field housing	Approx. 1.6 to 1.8 kg (3.53 to 3.97 lbs); depending on instrument version
Housing for DIN rail	Approx. 0.5 to 0.7 kg (1.10 to 1.54 lbs); depending on instrument version (→ 23 "Dimensions of the DIN-rail housing")
Separate display and operating module	Approx. 0.5 kg (1.10 lbs)

**Materials**

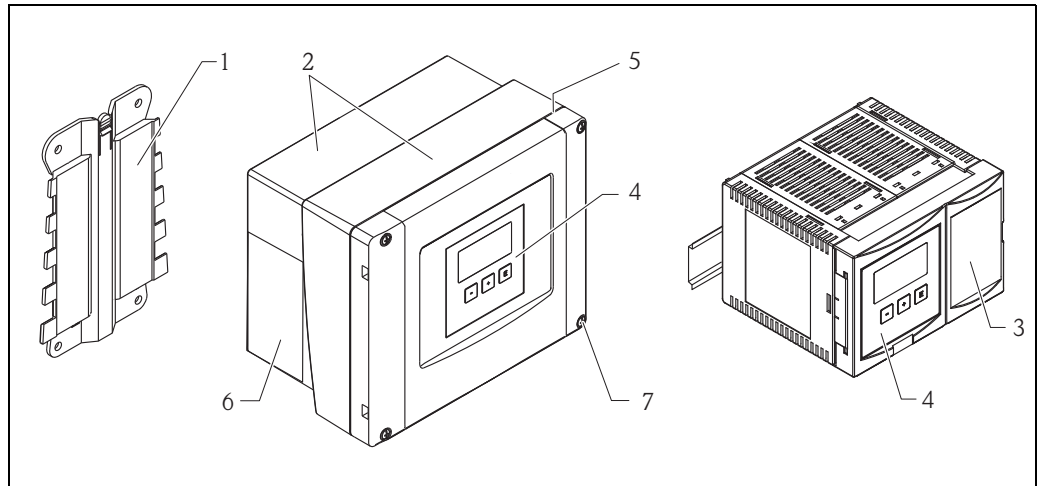

L00-FMU90xxx-06-00-00-xx-001

Pos.	Part	Material
1	Housing bracket	PC-FR
2	Field housing	PC-FR
3	Housing for DIN rail	PBT-GF
4	Separate display and operating module	PC
5	Sealing	PUR foam
6	Nameplate	Polyester
7	Screws	A4 (1.4578)

**Operability**

**Display and operating module**

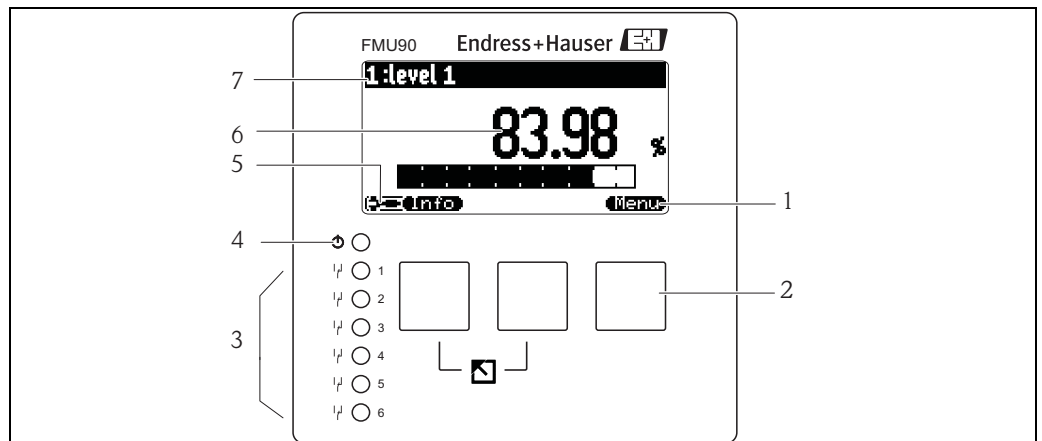

L00-FMU90xxx-07-00-00-xx-002

- 1 Softkey symbol
- 2 Key
- 3 LEDs indicating the switching states of the relays
- 4 LED indicating the operating state
- 5 Display symbols
- 6 Value of the parameter, including unit
- 7 Name of the parameter

## Display (Examples)

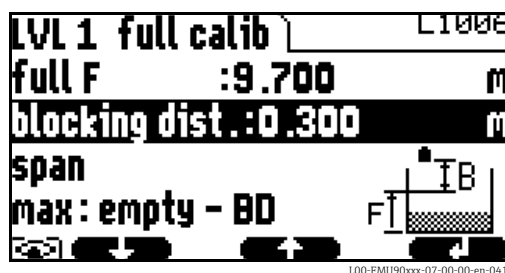

Display of a function including help text and descriptive graphic

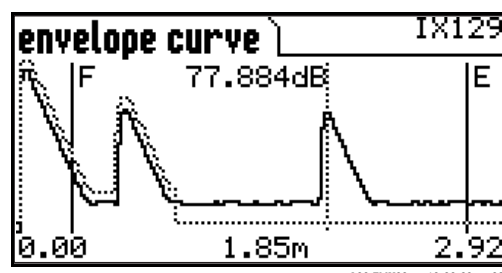

Display of the envelope curve including the mapping. The level echo and the empty distance are marked.

## Keys (softkey operation)

The function of the keys depends on the current position within the operating menu (softkey functionality). The key functions are indicated by softkey symbols in the bottom line of the display.

## LEDs

- 1 LED indicates the operating state ("normal operation", "alarm" or "warning")
- 6 LEDs indicate the switching state of the relays (LED glows if the respective relay is energised)

## Display

An illuminated display is available as an option (s. feature 40 of the product structure → 28)

## Operating menu

The Prosonic S has got a dynamical operating menu. Only those functions are visible which are relevant for the instrument version and installation environment at hand.

## Basic setup

The operating menu contains basic setups for easy commissioning of level and flow measurements. The basic setups guide the user through the complete commissioning procedure.

## Locking of the instrument

The instrument can be locked against parameter changes in the following ways:

- Locking switch in the terminal compartment
- Key combination at the operating module
- Input of a locking code via software (e.g. "FieldCare")

---

## Certificates and Approvals

---

<b>CE mark</b>	The measuring system meets the legal requirements of the EC-guidelines. Endress+Hauser confirms the instrument passing the required tests by attaching the CE-mark.
<b>Ex approval</b>	<p>The available certificates are listed in the ordering information. Note the associated safety instructions (XA) and control or installation drawings (ZD).</p> <p><b>Warning!</b></p> <ul style="list-style-type: none"> <li>■ Measuring systems for use in hazardous environments are accompanied by separate "Ex documentation", which is an integral part of this Operating Manual. Strict compliance with the installation instructions and ratings as stated in this supplementary documentation is mandatory. <ul style="list-style-type: none"> <li>– Ensure that all personnel are suitably qualified.</li> <li>– Observe the specifications in the certificate as well as national and local standards and regulations.</li> </ul> </li> <li>■ The transmitter may only be installed in suitable areas.</li> <li>■ Sensors with a certificate for hazardous areas may be connected to a transmitter without a certificate.</li> <li>■ For FM approvals: <ul style="list-style-type: none"> <li>Unauthorized substitution of components may impair the suitability for Division 1 or Division 2.</li> </ul> </li> <li>■ Do not disconnect equipment unless the area is known to be non-hazardous.</li> </ul> <p><b>Note!</b></p> <ul style="list-style-type: none"> <li>■ The sensor must be installed and used in a way that eliminates any danger. Possible installation positions: in tanks, vessels, silos, over stockpiles, open channels, weirs or other bins.</li> <li>■ Sensors FDU9x with Ex-approval can be connected to the transmitter FMU90 without Ex-approval.</li> </ul>
<b>External standards and guidelines</b>	<p><b>EN 60529</b> Protection class of housing (IP code)</p> <p><b>EN 61326 series</b> EMC product family standard for electrical equipment for measurement, control and laboratory use</p> <p><b>NAMUR</b> User association for automation technology in process industries</p> <p><b>US Standard UL 61010-1</b> CSA General Purpose Units FMU9x-N***** are tested according to US standard UL 61010-1, 2nd edition</p>

## Ordering information

### Product structure

<b>010</b>	<b>Approval</b>	
	R	Non-hazardous area
	J	ATEX II 3D
	N	CSA General Purpose
<b>020</b>	<b>Application</b>	
	1	Level + pump control, alternating
	2	Flow + totalizer + level + sample control + preprogrammed OCM flow curves
	3	Level + additional pump control
	4	Universal instrument (Level + Flow + Additional pump control)
<b>030</b>	<b>Housing, material</b>	
	1	Field mounting PC, IP66 NEMA 4x
	2	DIN rail mounting PBT, IP20
<b>040</b>	<b>Operation</b>	
	C	Illuminated display + keypad
	E	Illuminated display + keypad, 96x96, panel mounting, front IP65
	K	w/o display, via communication
<b>050</b>	<b>Power supply</b>	
	A	90-253 VAC
	B	10.5-32 VDC
<b>060</b>	<b>Level input</b>	
	1	1x sensor FDU9x/8x
	2	2x sensor FDU9x/8x
<b>070</b>	<b>Switch output</b>	
	1	1x relay, SPDT
	3	3x relay, SPDT
	6	6x relay, SPDT
<b>080</b>	<b>Output</b>	
	1	1x 0/4-20mA HART
	2	2x 0/4-20mA HART
	3	PROFIBUS DP
<b>090</b>	<b>Additional input</b>	
	A	w/o additional input
	B	4x limit switch + 1x temperature PT100/FMT131
<b>100</b>	<b>Datalog function</b>	
	A	Basic version
<b>110</b>	<b>Languages</b>	
	1	de, en, nl, fr, es, it, pt
	2	de, en, ru, pl, cs
	3	en, zh, ja, ko, th, id
<b>120</b>	<b>Additional option</b>	
	A	Basic version
	L	5-point linearity protocol only to order with FDU9x sensor + 5-point linearity protocol
<b>995</b>	<b>Marking</b>	
	1	Tagging (TAG)
	2	Bus address
FMU90 -		complete product designation

(\*): meaning of the language code:

cs: Czech; de: German; en: English; es: Spanish; fr: French; id: Bahasa (Indonesia, Malaysia); it: Italian; ja: Japanese; ko: korean; nl: Dutch; pl: Polish; pt: Portuguese; ru: Russian; th: Thai; zh: Chinese

**Scope of delivery**

- Instrument according to the version ordered
- Operating program: FieldCare
- Operating Instructions (depending on communication version → 35, "Documentation")
- For certified instrument versions: Safety Instructions (XAs) or Control Drawings (ZDs)→ 35, "Documentation"
- Field housing units for flow measurement FMU90-\*21\*\*\*\*\* are delivered with 2 screws for plombing the device

## Accessories

**Commubox FXA195 HART**

For intrinsically safe communication with FieldCare via the USB interface. For details refer to TI00404F/00/EN.

**Commubox FXA291**

The Commubox FXA291 connects Endress+Hauser field instruments with service interface to the USB interface of a personal computer or a notebook. For details refer to TI00405C/07/EN.

**Protection cover for the field housing**

- Material: 316Ti (1.4571)
- is mounted by the mounting help of the Prosonic S
- Order-Code: 52024477

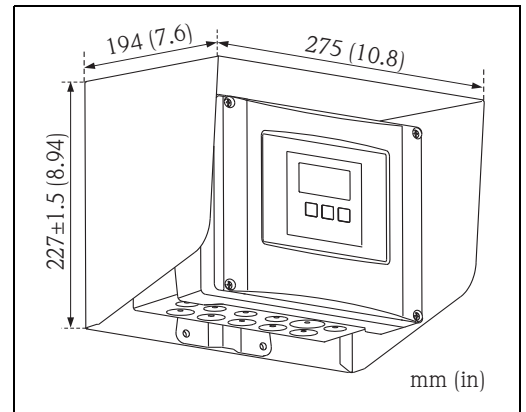

L00-FMU90xxx-06-00-00-xx-003

**Mounting plate for the field housing**

- suited for the mounting help of the Prosonic S
- for 1" - 2" tubes
- Dimensions: 210 mm x 110 mm (8.27 x 4.33 in)
- Material: 316Ti (1.4571)
- fixing clips, screws and nuts are supplied
- Order code: 52024478

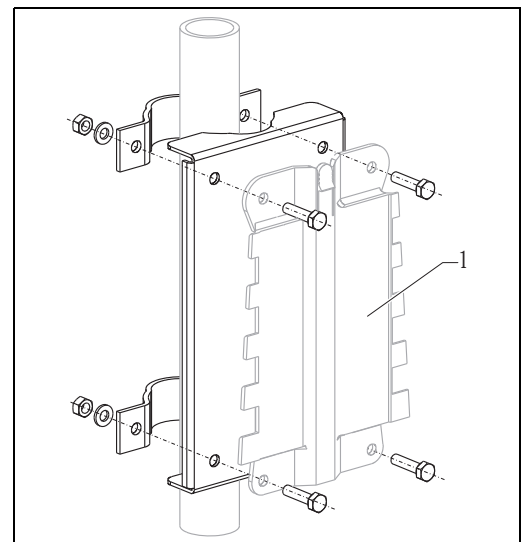

L00-FMU90xxx-00-00-00-xx-001

1 Mounting help of the field housing

## Mounting bracket

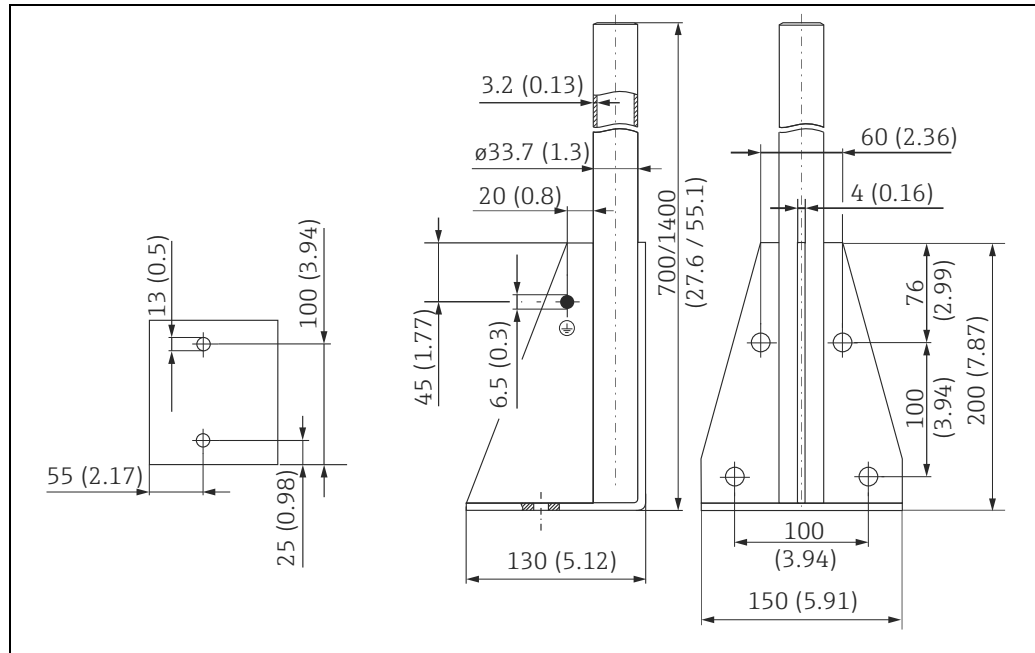

A0019279

Dimensions in mm (in)

Height	Material	Weight	Order Code
700 (27.6)	Galvanized steel	3.2 kg (7.06 lbs)	919791-0000
700 (27.6)	316Ti (1.4571)		919791-0001
1400 (55.1)	Galvanized steel	4.9 kg (10,08 lbs)	919791-0002
1400 (55.1)	316Ti (1.4571)		919791-0003

mm (in)

## Adaption plate for remote display

Used to mount the remote display into the opening 138 x 138 mm (5.43 x 5.43 in) of the remote display module of the Prosonic FMU860/861/862 (Display size: 144 x 44 mm (5.67 x 5.67 in)).

Order-Code: 52027441

## Note!

The adapter plate can be mounted directly in the housing of the old remote display of the FMU86x series. The housing of the remote display of FMU860/861/862 is the holder for the adapter plate and the new remote display of the FMU90/95 in the format 96 x 96 mm (3.78 x 3.78 in).

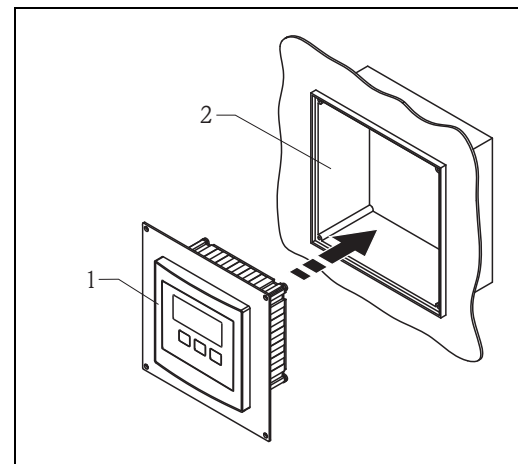

L00-FMU90xxxx-00-00-00-xx-001

- 1 Remote display of the Prosonic S with adaption plate
- 2 Opening of the remote display FMU860/861/862

## Option:

- Adaption plate 160 x 160 mm (6.3 x 6.3 in), thickness 3 mm (0.12 in), aluminum, opening 92 x 92 mm (3.62 x 3.62 in) for remote display of the FMU90 (size of the display: 96 x 96 mm (3.78 x 3.78 in)).
- Can be used to replace the FMU86x remote display or DMU2160/2260.
- Order Code: TSPFU 0390
- Contact Endress+Hauser: <http://www.endress.com/contact>



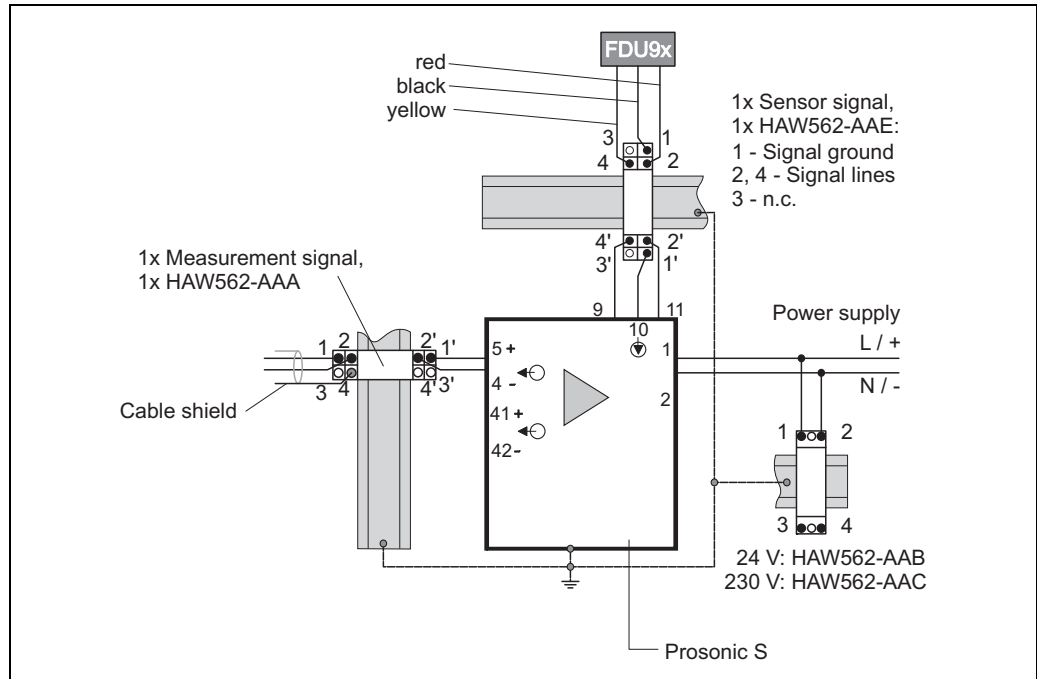

G09-HAW562xx-04-10-01-en-002

Level measurement with 1 Prosonic FDU9x level sensor, version 4 to 20 mA HART

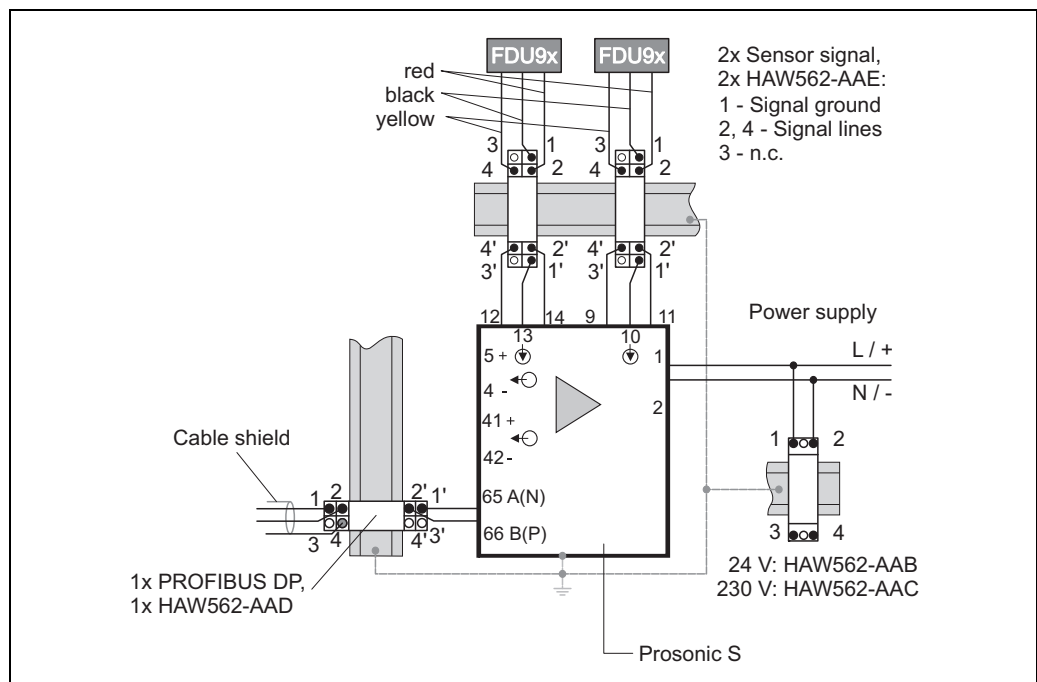

G09-HAW562xx-04-10-01-en-003

Level measurement with 2 Prosonic FDU9x level sensors, version PROFIBUS DP

**Ordering information**

Surge Arrester HAW562, compact device for DINrail installation in signal and power supply lines and communication lines protecting field devices and systems against overvoltage and magnetic induction.

Approval				
AA				Non-hazardous area
8D				ATEX II 2 (1)G Ex ia IIC T6
Application				
A				Measuring signal 0/4-20 mA, PFM, PA, FF
B				Supply voltage 10-55 V (+/-20 %)
C				Supply voltage 90-230 V (+/-10 %)
D				Communication RS485/MOD-Bus/PROFIBUS DP
E				Protection module Prosonic FMU90
+ Additional selection (option)				
Additional approvals				
LA				SIL
Accessory enclosed				
PA				Screen grounding terminal
PB				Field housing
PC				Mounting bracket, wall/pipe
Marking				
Z1				Tagging (TAG), metal
Z3				Commissioning label, paper
Z6				Tagging (TAG), by customer
HAW562			+	complete product designation
-				

For details see Technical Informations TI01012K and TI01013K and the Operating Instruction BA00306K.

Temperature sensor FMT131

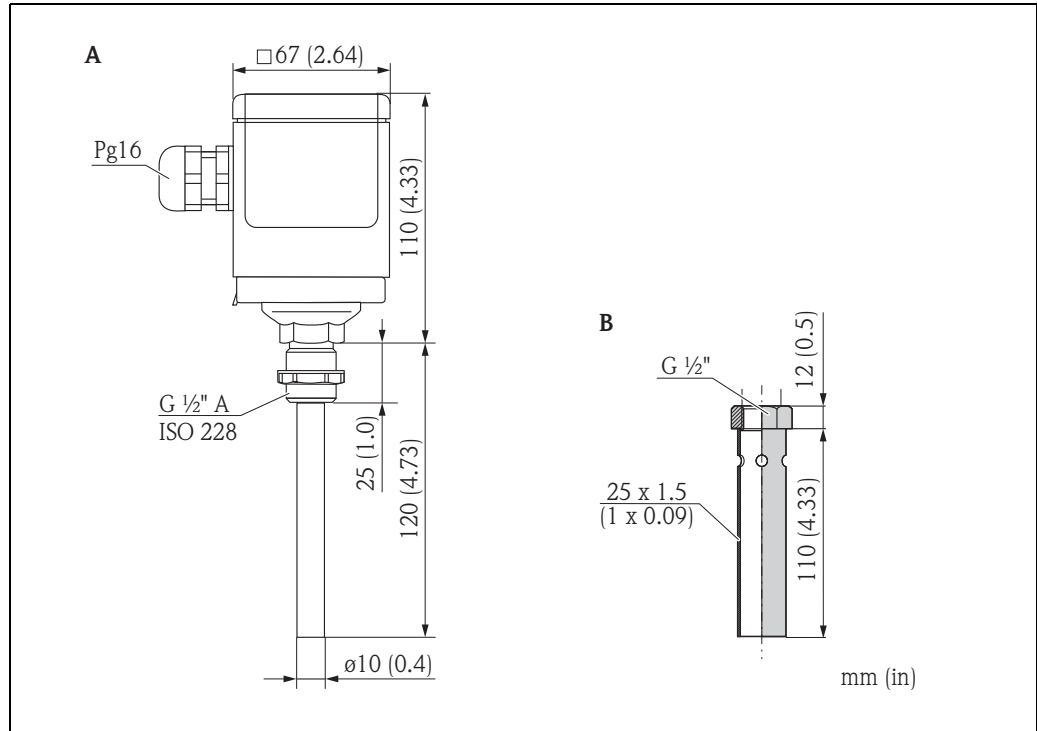

L00-FMU90xxx-00-00-00-xx-002

A Temperature sensor FMT131  
 B Weather protector

Product structure

<b>010</b>	<b>Approval</b>
	R Non-hazardous area J ATEX II 2G EEx m II T6/T5 Q FM Cl.I Div. 1 Gr. A-D, zone 1, 2 U CSA General Purpose (in preparation) S CSA Class I Div. 1
<b>020</b>	<b>Cable length</b>
	1 5 m/16 ft 2 10 m/ 32 ft 3 15 m/49 ft 4 20 m/65 ft 5 25 m/82 ft 6 30 m/98 ft 7 w/o cable, gland Pg16, IP66 8 ... m A ... ft
<b>995</b>	<b>Marking</b>
	1 Tagging (TAG)
FMT131 -	complete product designation

Weather protection cover for FMT131

Order code: 942046-0000



The FMT131 for use in hazardous areas is completely plotted and is always supplied with cable. The FMT131 version for non-hazardous areas (FMT131-R\*) is supplied without cable.

## Documentation

### Technical Information

#### TI00396F

Technical Information for the ultrasonic sensors FDU90/FDU91/FDU91F/FDU92/FDU93/FDU95<sup>10)</sup>

### Operating instructions (for transmitter FMU90)

Depending on the instrument version, the following operating instructions are supplied with the Prosonic S FMU90:

Operating instructions	Output	Application	Instrument version
BA00288F	HART	<ul style="list-style-type: none"> <li>■ level measurement</li> <li>■ alternating pump control</li> <li>■ screen and rake control</li> </ul>	FMU90 - *1***** FMU90 - *2*****
BA00289F		<ul style="list-style-type: none"> <li>■ flow measurement</li> <li>■ backwater and dirt detection</li> <li>■ totalizers and counters</li> </ul>	FMU90 - *1***** FMU90 - *1***** FMU90 - *2***** FMU90 - *2*****
BA00292F	PROFIBUS DP	<ul style="list-style-type: none"> <li>■ level measurement</li> <li>■ alternating pump control</li> <li>■ screen and rake control</li> </ul>	FMU90 - *3*****
BA00293F		<ul style="list-style-type: none"> <li>■ flow measurement</li> <li>■ backwater and dirt detection</li> <li>■ totalizers and counters</li> </ul>	FMU90 - *3***** FMU90 - *3*****

These operating instructions describe installation and commissioning of the respective version of the Prosonic S. It contains those functions from the operating menu, which are required for a standard measuring task. Additional functions are described in this document: Description of Instrument Functions for Prosonic S FMU90, document number BA00290F.

### Description of Instrument Functions

#### BA00290F

The document BA00290F contains a detailed description of **all** functions of the Prosonic S and is valid for all instrument versions.

You will find this document in the Download Area of the Endress+Hauser Internet site:  
[www.endress.com](http://www.endress.com) → Download

### Safety Instructions

#### XA00326F

Safety Instructions for ATEX II 3D

10) The sensors FDU80/80F/81/81F/82/83/84/85/86/96 are not available anymore.  
 Use the serial number of your device to access the documentation for your device via [www.endress.com](http://www.endress.com).



[www.addresses.endress.com](http://www.addresses.endress.com)

---