

UMG 509-PRO

Multifunction power analyser with RCM

Power quality



Ethernet connection



Graphic programming

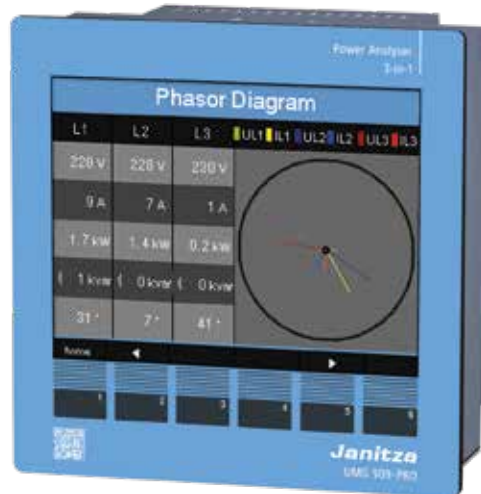

Residual current monitoring



Ethernet-Modbus gateway



Alarm management

Communication

- Profibus (DP/V0)
- Modbus (RTU, TCP, Gateway)
- TCP/IP
- BACnet (optional)
- HTTP (Homepage)
- FTP (File transfer)
- SNMP
- TFTP
- NTP (time synchronisation)
- SMTP (email function)
- DHCP

Interfaces

- Ethernet
- Profibus (DSUB-9)
- RS485 Modbus (terminal strip)

Accuracy of measurement

- Energy: Class 0.2S (... / 5 A)
- Current: 0.2 %
- Voltage: 0.1 %

Power quality

- Harmonics up to 63th harmonic
- Short-term interruptions (> 20 ms)
- Transient recorder (> 50 µs)
- Starting currents (> 20 ms)
- Unbalance

Networks

- IT, TN, TT networks
- 3 and 4-phase networks
- Up to 4 single-phase networks

Measured data memory

- 256 MByte Flash
- 32 MB SDRAM

PLC functionality

- Graphical programming
- Jasic® programming language
- Programming of threshold values etc.

2 digital inputs

- Pulse input
- Logic input
- State monitoring
- HT / LT switching

2 digital outputs

- Pulse output kWh / kvarh
- Switch output
- Threshold value output
- Logic output

Network visualisation software

- Free GridVis®-Basic

Thermistor input

- PT100, PT1000, KTY83, KTY84

RCM – Residual Current Monitoring

- 2 residual current inputs



Areas of application



- Continuous monitoring of the power quality
- Energy management systems (ISO 50001)
- Master device with Ethernet gateway for subordinate measurement points
- Visualisation of the energy supply in the LVDB
- Analysis of electrical disturbances in the event of power quality problems
- Cost centre analysis
- Remote monitoring in the property operation
- Use in test fields (e.g. in universities)

Main features

High quality measurement with high sampling rate (20 kHz per channel)



Power quality

- Harmonics analysis up to 63rd harmonic
- Acquisition of short-term interruptions
- Acquisition of transients
- Display of waveforms (current and voltage)
- Unbalance
- Vector diagram

RCM (Residual Current Monitoring)



- Continuous monitoring of residual currents (Residual Current Monitor, RCM)
- Alarming in case a preset threshold fault current reached
- Near-realtime reactions for triggering countermeasures
- Permanent RCM measurement for systems in permanent operation without the opportunity to switch off
- Ideal for the central earthing point in TN-S systems

Modern communications architecture via Ethernet



- Ethernet interface and web server
- Faster, better cost-optimised and more reliable communication system
- High flexibility due to the use of open standards
- Integration in PLC systems and BMS through additional interfaces
- BACnet optionally available
- Up to 4 ports simultaneous
- Versatile IP protocols

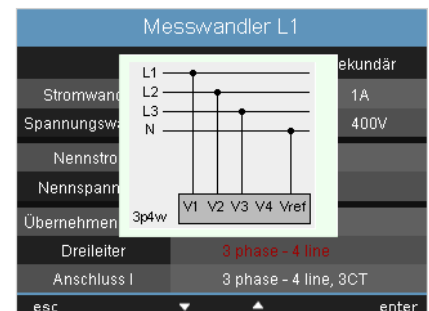

Fig.: Example for the configuration of current measurement via 3 current transformers in a three-phase 4-wire network on the UMG 509-PRO display

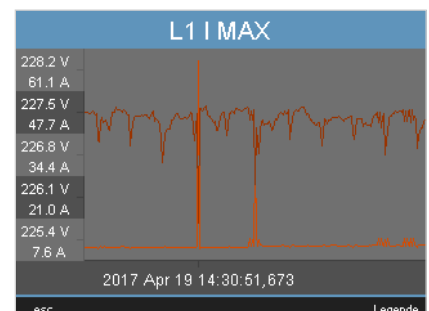

Fig.: Illustration of the full wave effective values for an event (voltage drop)



Modbus Gateway function

- Economical connection of devices without Ethernet interface
- Integration of devices with Modbus-RTU interface possible
- Data can be scaled and described
- Minimised number of IP addresses required



Graphical programming

- Comprehensive programming options (PLC functionality)
- Jasic® source code programming
- Sustainable functional expansions far beyond pure measurement
- Complete APPs from the Janitza library



Powerful alarm management

- Can be programmed via the graphic programming or Jasic® source code
- All measured values can be used
- Can be arbitrarily, mathematically processed
- Individual forwarding via email sending, switching of digital outputs, writing to Modbus addresses etc.
- Watchdog APPs
- Further alarm management functions via GridVis®-Service alarm management

Timestamp	Alarmtext	Typ	Bestandigkeit
27.03.14 15:22:20937	27.03.14 15:45:07763	Spannungserhöhung	1
27.03.14 15:22:46139	27.03.14 15:45:28444	Spannungserhöhung	1
27.03.14 15:22:46139	27.03.14 15:45:46139	Spannungserhöhung	1
27.03.14 15:22:46139	27.03.14 15:45:46139	Spannungserhöhung	1
27.03.14 15:22:46139	27.03.14 15:45:46139	Spannungserhöhung	1
27.03.14 15:22:46139	27.03.14 15:45:46139	Spannungserhöhung	1
27.03.14 15:22:46139	27.03.14 15:45:46139	Spannungserhöhung	1
27.03.14 15:22:46139	27.03.14 15:45:46139	Spannungserhöhung	1
27.03.14 15:22:46139	27.03.14 15:45:46139	Spannungserhöhung	1
27.03.14 15:22:46139	27.03.14 15:45:46139	Spannungserhöhung	1

Fig.: GridVis® – Alarmmanagement

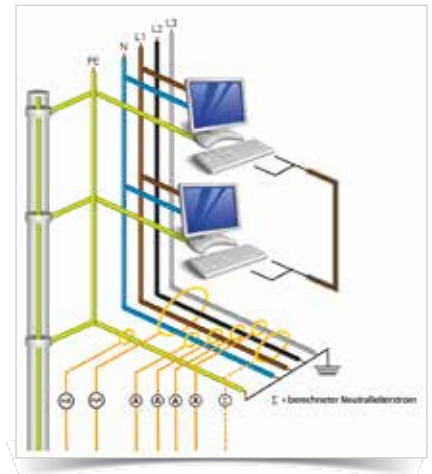

Fig.: Example RCM measurement



↑
Ethernet connection



Dimension diagrams

All dimensions in mm

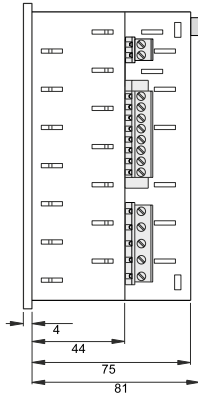

Side view

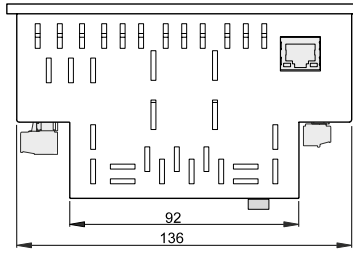

View from below

Cut out: $138^{+0,8} \times 138^{+0,8}$ mm



Typical connection

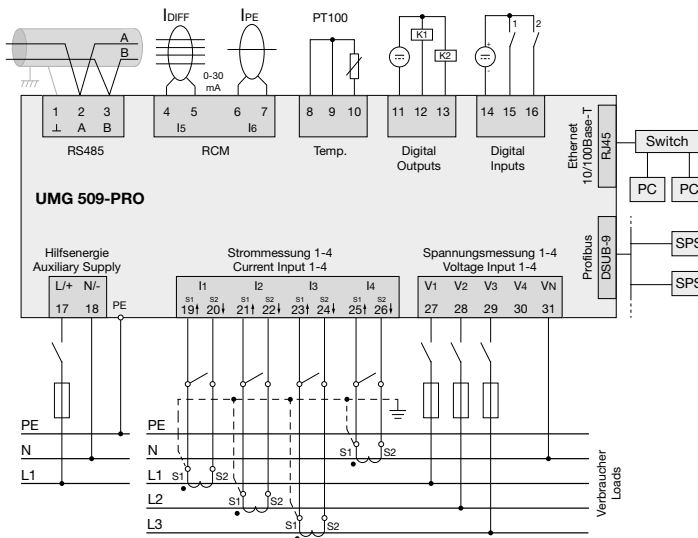



Device overview and technical data

Item number	UMG 509-PRO	
	52.26.001	52.26.003
AC supply voltage	95 to 240 V AC	48 to 110 V AC
Supply voltage DC	80 to 300 V DC	24 to 150 V DC
Device options		
BACnet communication	52.26.081	52.26.081

General	
Net weight (with attached connectors)	approx. 1080 g
Device dimensions	approx. l = 144 mm, w = 144 mm, h = 75 mm
Battery	type Li-Mn CR2450, 3V (approval i.a.w. UL 1642)
Clock (in temperature range -40°C to 85°C)	+5 ppm (corresponding to approx. 3 minutes per year)

Transport and storage	
The following information applies to devices which are transported or stored in the original packaging.	
Free fall	1 m
Temperature	-25° C to +70° C

Ambient conditions during operation	
The device is intended for weather-protected, stationary use. The device must be connected to the ground wire connection! Protection class I in acc. with IEC 60536 (VDE 0106, Part 1).	
Working temperature range	-10° C to +55° C
Relative humidity	5 to 95% (at 25° C) without condensation
Operating altitude	0 to 2000 m above sea level
Pollution degree	2
Installation position	upright
Ventilation	forced ventilation is not required.
Protection against ingress of solid foreign bodies and water	IP40 in acc. with EN60529 IP20 in acc. with EN60529

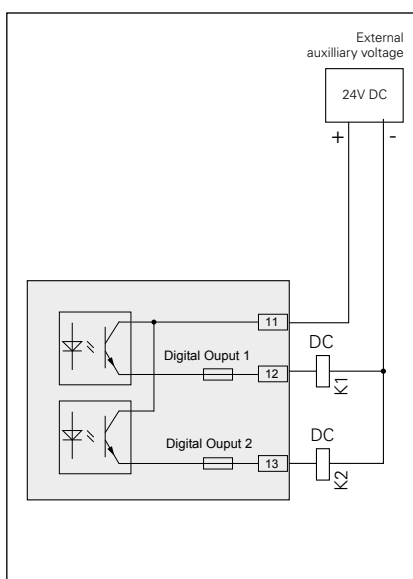

Fig. Example for two electronic relays connected to the digital outputs

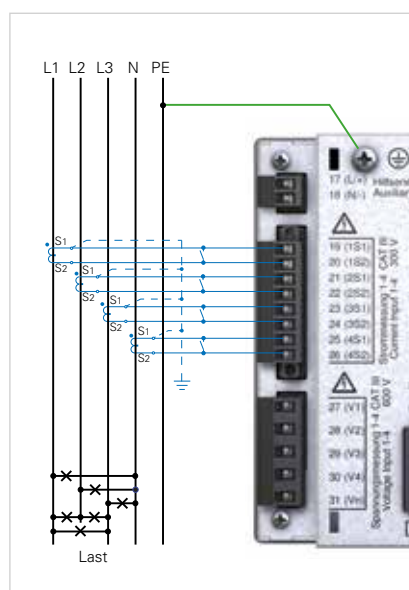

Fig.: Example current measurement

Chapter 02

UMG 509-PRO

Supply voltage	
Installations of overvoltage category	300 V CAT III
Protection of the supply voltage (fuse)	6 A, type B (approved as per UL/IEC)
230 V option: - Nominal range - Operating range - Power consumption	95 V to 240 V (50/60 Hz) / DC 80 V to 300 V ± 10% of nominal range max. 7 W / 14 VA
24V option: • Nominal range • Operating range • Power consumption	48 V to 110 V (50/60 Hz) or DC 24 to 150 V ± 10% of nominal range max. 9 W / 13 VA

Terminal connection capacity (supply voltage)	
Connectable conductors. Only one conductor can be connected per terminal!	
Single core, multi-core, fine-stranded	0.2 – 2.5 mm ² , AWG 24 - 12
Terminal pins, core end sheath	0.25 – 2.5 mm ²
Tightening torque	0.5 – 0.6 Nm
Stripping length	7 mm

Current measurement	
Rated current	5 A
Resolution	0.1 mA
Metering range	0.005 to 7 A _{rms}
Measurement range exceeded (overload)	from 7.5 A _{rms}
Crest factor	2.4
Overvoltage category	230 V option: 300 V CAT III 24 V option: 300 V CAT II
Measurement voltage surge	4 kV
Power consumption	approx. 0.2 VA (Ri = 5 mOhm)
Overload for 1 sec.	120 A (sinusoidal)
Sampling rate	20 kHz / phase

Voltage measurement	
The voltage measurement inputs are suitable for measurements in the following power supply systems:	
Three-phase 4-conductor systems with rated voltages up to	417 V / 720 V 347 V / 600 V UL listed
Three-phase 3-conductor systems with rated voltages up to	600 V
From a safety and reliability perspective, the voltage measurement inputs are designed as follows:	
Overvoltage category	600 V CAT III
Measurement voltage surge	6 kV
Protection of voltage measurement	1 – 10 A
Metering range L-N	0 ¹⁾ to 600 V _{rms}
Metering range L-L	0 ¹⁾ to 1000 V _{rms}
Resolution	0.01 V
Crest factor	1.6 (related to 600 V _{rms})
Impedance	4 MOhm / phase
Power consumption	approx. 0.1 VA
Sampling rate	20 kHz / phase
Transients	> 50 µs
Frequency of the fundamental oscillation - Resolution	40 Hz to 70 Hz 0.001 Hz

1) The device can only determine measured values, if an L-N voltage of greater than 10 Veff or an L-L voltage of greater than 18 Veff is applied to at least one voltage measurement input.

Phase angle accuracy of measurement	0.075°
-------------------------------------	--------

Terminal connection capacity (voltage and current measurement)	
Connectable conductors. Only one conductor can be connected per terminal!	
Single core, multi-core, fine-stranded	0.2 – 2.5 mm ² , AWG 24-12
Terminal pins, core end sheath	0.25 – 2.5 mm ²
Tightening torque	0.5 – 0.6 Nm
Stripping length	7 mm

Residual current monitoring (RCM)	
Rated current	30 mA _{rms}
Metering range	0 to 40 mA _{rms}
Triggering current	100 µA
Resolution	1 µA
Crest factor	1.414 (related to 40 mA)
Burden	4 Ohm
Overload for 1 sec.	5 A
Sustained overload	1 A
Overload for 20 ms	50 A
Residual current monitoring	as per IEC/TR 60755 (2008-01), Type A
Maximum external burden	300 Ohm (for cable break detection)

Terminal connection capacity (residual current monitoring)	
Connectable conductors. Only one conductor can be connected per terminal!	
Rigid/flexible	0.14 – 1.5 mm ² , AWG 28-16
Flexible with core end sheath without plastic sleeve	0.20 – 1.5 mm ²
Flexible with core end sheath with plastic sleeve	0.20 – 1.5 mm ²
Stripping length	7 mm
Tightening torque	0.20 – 0.25 Nm
Cable length	up to 30 m unshielded, from 30 m shielded

Temperature measurement input	
3-wire measurement	
Update time	1 second
Connectable sensors	PT100, PT1000, KTY83, KTY84
Total burden (sensor + cable)	max. 4 kOhm
Cable length	up to 30 m unshielded, from 30 m shielded

Sensor type	Temperature range	Resistor range	Measurement uncertainty
KTY83	-55° C to +175° C	500 Ohm to 2.6 kOhm	± 1.5% rng
KTY84	-40° C to +300° C	350 Ohm to 2.6 kOhm	± 1.5% rng
PT100	-99° C to +500° C	60 Ohm to 180 Ohm	± 1.5% rng
PT1000	-99° C to +500° C	600 Ohm to 1.8 kOhm	± 1.5% rng

Terminal connection capacity (temperature measurement input)	
Connectable conductors. Only one conductor can be connected per terminal!	
Single core, multi-core, fine-stranded	0.08 – 1.5 mm ²
Terminal pins, core end sheath	1 mm ²

Chapter 02

UMG 509-PRO

Digital inputs	
2 Digital inputs with a joint earth	
Maximum counter frequency	20 Hz
Response time (Jasic program)	200 ms
Input signal present	18 V to 28 V DC (typical 4 mA)
Input signal not present	0 to 5 V DC, current less than 0.5 mA
Cable length	up to 30 m unshielded, from 30 m shielded

Digital outputs	
2 digital outputs with a joint earth; opto coupler, not short-circuit proof	
Supply voltage	20 V - 30 V DC (SELV or PELV supply)
Switching voltage	max. 60 V DC, 30 V AC
Switching current	max. 50 mA _{eff} AC/DC
Response time (Jasic program)	200 ms
Output of voltage dips	20 ms
Output of voltage exceedance events	20 ms
Switching frequency	max. 20 Hz
Cable length	up to 30 m unshielded, from 30 m shielded

Terminal connection capacity (digital inputs and outputs)	
Rigid/flexible	0.14 - 1.5 mm ² , AWG 28-16
Flexible with core end sheath without plastic sleeve	0.25 - 1.5 mm ²
Flexible with core end sheath with plastic sleeve	0.25 - 0.5 mm ²
Tightening torque	0.22 - 0.25 Nm
Stripping length	7 mm

RS485 interface	
3-wire connection with GND, A, B	
Protocol	Modbus RTU/slave, Modbus RTU/master, Modbus RTU /gateway
Transmission rate	9.6 kbps, 19.2 kbps, 38.4 kbps, 57.6 kbps, 115.2 kbps, 921.6 kbps
Termination resistor	can be activated by micro switch

Profibus interface	
Connection	SUB D 9-pole
Protocol	Profibus DP/V0 per EN 50170
Transmission rate	9.6 kBaud to 12 MBaud

Ethernet interface	
Connection	RJ45
Function	Modbus gateway, embedded web server (HTTP)
Protocols	CP/IP, EMAIL (SMTP), DHCP client (BootP), Modbus/TCP, Modbus RTU over Ethernet, FTP, ICMP (Ping), NTP, TFTP, BACnet (optional), SNMP

Firmware	
Firmware update	Update via GridVis [®] software. Firmware download (free of charge) from the website: http://www.janitza.com

Comment: For detailed technical information please refer to the operation manual and the Modbus address list.