**User's
Manual**

YS1000 Series

**YS1310 Indicator with Alarm
User's Manual**

**Functional
Enhancement**

IM 01B08D02-02EN

Introduction

Thank you for purchasing the YS1000 series single-loop controller (hereinafter referred to as "YS1000").

This manual describes how to use YS1310 functions other than communication function. Please read through this user's manual carefully before using the product.

Note that the manuals for the YS1310 comprise the following five documents:

- **Printed manual**

Manual Name	Manual Number	Description
YS1310 Operation Guide	IM 01B08D02-01EN	This manual describes the basic operation method.

- **Electronic manuals**

Manual Name	Manual Number	Description
YS1310 Operation Guide	IM 01B08D02-01EN	This is identical to the printed manual.
YS1310 User's Manual	IM 01B08D02-02EN	This manual. It describes the usage of all functions except the communication functions.
YS1000 Series Communication Interface User's Manual	IM 01B08J02-01EN	This manual describes how to use YS1000 in Ethernet, and serial communications. For communication wiring, see the Operation Guide.
YSS1000 Setting Software/YS1700 Programmable Function User's Manual	IM 01B08K02-02EN	This manual describes how to use YSS1000 and YS1700's programmable function and peer-to-peer communication function.
YS1000 Series Replacement Manual	IM 01B08H02-01EN	This manual describes the compatibility of installation and wiring with YS100, YS80, EBS, I, EK, HOMAC, and 100 line.

User's manuals for YS1000 are available on the following web site: www.yokogawa.com/ns/ys/im/

You need Adobe Reader 7.0 or later (but the latest version is recommended) installed on the computer in order to open and read the manuals.

Notice

- The contents of this manual are subject to change without notice as a result of continuing improvements to the instrument's performance and functions.
- Every effort has been made to ensure accuracy in the preparation of this manual. Should any errors or omissions come to your attention, however, please inform YOKOGAWA Electric's sales office or sales representative.
- Under no circumstances may the contents of this manual, in part or in whole, be transcribed or copied without our permission.

Trademarks

- Our product names or brand names mentioned in this manual are the trademarks or registered trademarks of YOKOGAWA Electric Corporation (hereinafter referred to as YOKOGAWA).
- Microsoft, MS-DOS, Windows are either registered trademarks or trademarks of Microsoft Corporation in the United States and/or other countries.
- Adobe, Acrobat, and Postscript are either registered trademarks or trademarks of Adobe Systems Incorporated.
- Ethernet is a registered trademark of XEROX Corporation.
- We do not use the TM or ® mark to indicate these trademarks or registered trademarks in this user's manual.
- All other product names mentioned in this user's manual are trademarks or registered trademarks of their respective companies.

How to Use This Manual

Usage

First read through the Operation Guide to understand the basic operations and then read this manual. For the communication functions, and replacements, see the respective manuals.

This User's Manual is organized into Chapters 1 to 6 as shown below:

Chapter	Title and Description
1	Input/output and Auxiliary Function Describes the input/output function, operation, and setting items.
2	Display Function/Security Function Provides the LCD display functions, adjustments, and setting items.
3	Adjustment of Direct Inputs (Temperature, Resistance, and Frequency) Describes the settings and adjustments for the direct input converter built into the YS1310.
4	Power Failure Recovery Processing Describes operations performed after momentary power interruption and power failures.
5	Maintenance Describes ordinary inspections, indicating accuracy inspections, and part replacement cycles.
6	Specifications Provides the YS1310 specifications.

Symbols Used in This Manual



This symbol is used on the instrument. It indicates the possibility of injury to the user or damage to the instrument, and signifies that the user must refer to the user's manual for special instructions. The same symbol is used in the user's manual on pages that the user needs to refer to, together with the term "WARNING" or "CAUTION."

WARNING

Calls attention to actions or conditions that could cause serious or fatal injury to the user, and indicates precautions that should be taken to prevent such occurrences.

CAUTION

Calls attention to actions or conditions that could cause injury to the user or damage to the instrument or property and indicates precautions that should be taken to prevent such occurrences.

Note

Identifies important information required to operate the instrument.



Indicates related operations or explanations for the user's reference.



Indicates a character string displayed on the display.

Setting Display

Indicates a setting display and describes the keystrokes required to display the relevant setting display.

Setting Details

Provides the descriptions of settings.

Description

Describes restrictions, etc. regarding a relevant operation.

Contents

Introduction	i
How to Use This Manual	ii
Symbols Used in This Manual	iii
Chapter 1 Input/output and Auxiliary Function	
1.1 Function Block Diagram	1-1
1.2 Compensating or Computing Process Variables	1-2
1.2.1 Input Filter (First-order Lag Operation)	1-2
1.2.2 Square Root Extraction (Low Cutoff Adjustable)	1-2
1.3 Setting Alarm Function	1-3
1.4 Setting Alarm Output Hysteresis	1-5
1.5 Using Alarm Output 6 as Digital Input (LCD Backlight OFF Input, All Event OFF)	1-6
1.6 Using the Event Function	1-7
1.6.1 Displaying Messages (Event Display Function (Settable Only in YSS1000))	1-7
1.6.2 Changing the PV Bar Display Color in the Event of a Process Alarm (Active Display Function) ..	1-9
1.6.3 Operator Notification Using Tag Number Display (Alternate Tag Number Color Display Function)	1-10
Chapter 2 Display and Security Functions	
2.1 Display Function	2-1
2.1.1 Setting Visible/Invisible Status of the Operation Display	2-1
2.1.2 Setting Visible/Invisible Status of TREND Display Data	2-4
2.1.3 Changing the Time Span of TREND Displays	2-5
2.1.4 Setting Display Data on the TREND 3 Display	2-6
2.1.5 Changing Scale Divisions on the LOOP, TREND, and DUAL Displays	2-7
2.1.6 Automatic Scale Divisions/Making Scale Values More Legible on the METER Display	2-8
2.1.7 Selecting the Operation Display to be Displayed First at Power ON	2-9
2.1.8 Turning the LCD Backlight ON/OFF	2-10
2.1.9 Changing the Background and Loop Colors	2-11
2.1.10 Adjusting LCD Brightness	2-12
2.2 Security Function	2-13
2.2.1 Inhibiting/Enabling Parameter Change	2-13
Chapter 3 Adjusting Direct Inputs (Temperature/Resistance/Frequency)	
3.1 List of Direct Input Specifications and Basic Operations	3-1
3.2 Setting Sensor Type	3-4
3.3 Setting Burnout	3-5
3.4 Making Zero and Span Adjustments of Input	3-6
Chapter 4 Processing during Power Failures	
4.1 Processing during Power Failures	4-1
Chapter 5 Maintenance	
5.1 Inspecting Indication Accuracy	5-1
5.1.1 Calibration Instruments	5-1
5.1.2 Inspecting Input Indication Accuracy	5-1
5.2 Recommended Part Replacement Period	5-2
5.3 Packaging when Shipping the Product for Repair	5-3

Chapter 6 Specifications

6.1 General Specifications 6-1

Index

Revision Information

1.1 Function Block Diagram

The following figure shows the function configuration.

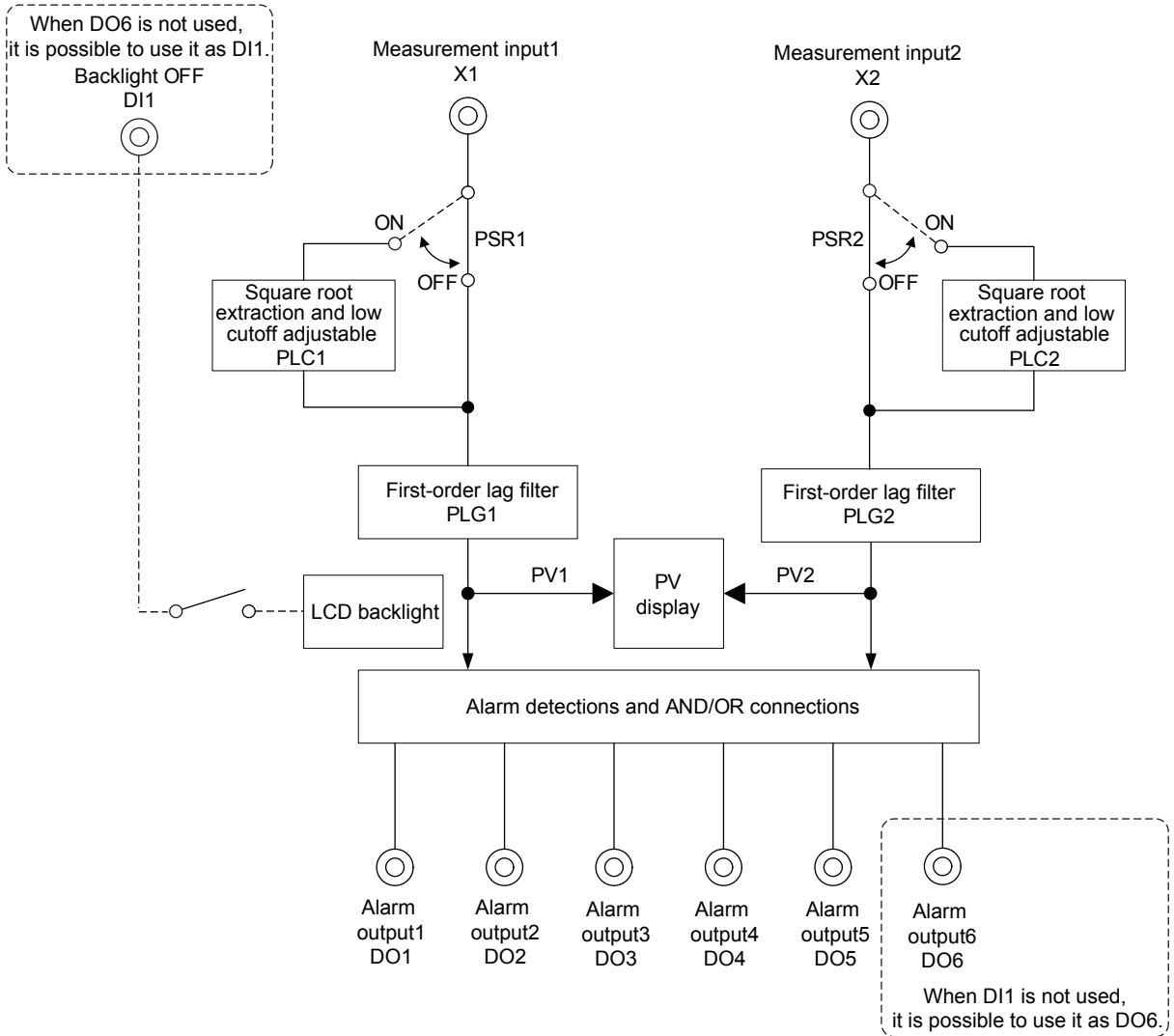

Function Block Diagram

0101E.ai

Main parameter Functions

Main Functions	Reference Destination
Filter function	1.2.1 Input Filter (First-order Lag Computation)
Square root extraction	1.2.2 Square Root Extraction (Low Cut off Adjustable)
Alarm function	1.3 Setting Alarm Function

Other Functions

Main Functions	Reference Destination
Display function	Chapter 2, Display/Security Functions.
Communication function	YS1000 Series Communication Interface User's Manual

1.2 Compensating or Computing Process Variables

1.2.1 Input Filter (First-order Lag Operation)

Description

First-order lag operation is performed on each analog input. This function is used if there are significant variations in the display value such as the presence of noise. The greater the time constant, the stronger the filtering function.

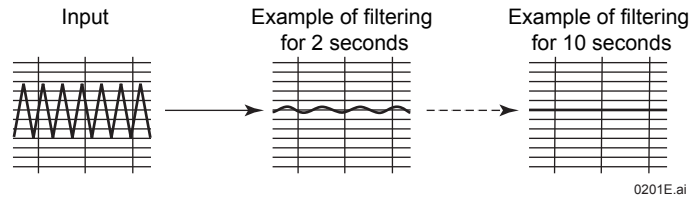

Setting Details

Parameter	Name	Setting Range	Display Transition and Display Title
PLG1, PLG2	First-order lag time constant for PV	0.0 to 800.0 sec	Tuning Display > [SETTING1] (Setting Display 1) or [SETTING2] (Setting Display 2)

The PLG2 parameter is used for the loop 2.

1.2.2 Square Root Extraction (Low Cutoff Adjustable)

Description

Square root extraction is performed on a process variable (PV). The input and output characteristics are that input = output at the low cutoff point or below. There is no hysteresis.

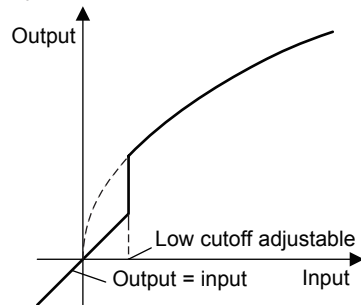

Square Root Extraction Characteristics

Setting Details

Parameter	Name	Setting Range	Display Transition and Display Title
PSR1, PSR2	Square root extraction for PV	OFF: Without square root extraction ON: With square root extraction	Tuning Display > Engineering Display > [CONFIG3] (Configuration Display 3)
PLC1, PLC2	Square root extraction low cutoff setpoint for PV	0.0 to 100.0%	Tuning Display > [SETTING1] (Setting Display 1) or [SETTING2] (Setting Display 2)

The PSR2, and PLC2 parameters are used for the loop 2.

1.3 Setting Alarm Function

Description

Alarm output function

Six alarm outputs are available (if DIO1 is not used). Each of these six output points can be assigned alarm detection (high limit, low limit, high-high limit, and low-low limit). If multiple alarm detections are assigned to one alarm output, AND or OR connection can be set. The direction of contact action at occurrence of alarm can be set as open or closed in the event of an alarm.

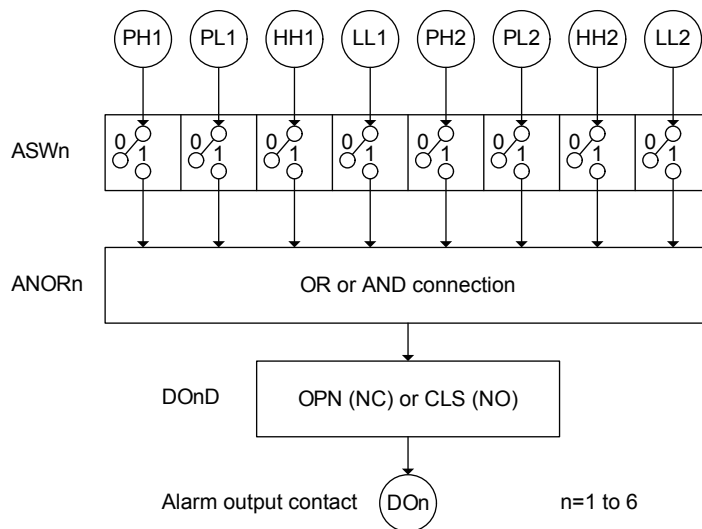

- ASWn:** There are eight digits where “0” or “1” is set, which correspond to PH1, PL1, HH1, LL1, PH2, PL2, HH2, and LL2 from the left. “0” means no alarm output, while “1” denotes that alarm output is provided. To output PL1, set these digits to “01000000”. To output PH1 and PL1, set them to “11000000”. If multiple alarm detections are assigned to one alarm output, connect these contacts in AND or OR connection.
- ANORn:** If multiple alarm detections have been set to ASWn, set AND or OR connection using this parameter. (If only one alarm detection is set to ASWn, it is not necessary to set ANORn.)
- DOnD:** Sets the direction of contact action in the event of alarm output.
 OPN: Open if an alarm occurs (NC: Normally closed)
 CLS: Closed if an alarm occurs (NO: Normally open)

1.3 Setting Alarm Function

Alarm Detecting Function

This function can detect the high limit alarm (PH), low limit alarm (PL), high-high limit alarm (HH), and low-low limit alarm (LL) with respect to process variables 1 and 2. Alarm hysteresis can also be set for both process variables 1 and 2. The alarm detecting action is shown in the figure below.

(If the high limit alarm and high-high limit alarm are set to the maximum values and the low limit alarm and low-low limit alarm are set to the minimum values, no alarm is detected.)

The following shows the relationship of alarm detection in parameters.

High limit alarm for PV1 (PH1) and high limit alarm for PV2 (PH2): Engineering units equivalent to -6.3 to 106.3%

Low limit alarm for PV1 (PL1) and low limit alarm for PV2 (PL2): Engineering units equivalent to -6.3 to 106.3%

High-high limit alarm for PV1 (HH1) and high-high limit alarm for PV2 (HH2): Engineering units equivalent to -6.3 to 106.3%

Low-low limit alarm for PV1 (LL1) and low-low limit alarm for PV2 (LL2): Engineering units equivalent to -6.3 to 106.3%

Alarm hysteresis 1 and alarm hysteresis 2: Engineering unit span equivalent to 0.1 to 20.0%

The following figure shows an example of actions of the high limit alarm for PV, high-high limit alarm for PV, low limit alarm for PV, low-low limit alarm for PV, and alarm hysteresis.

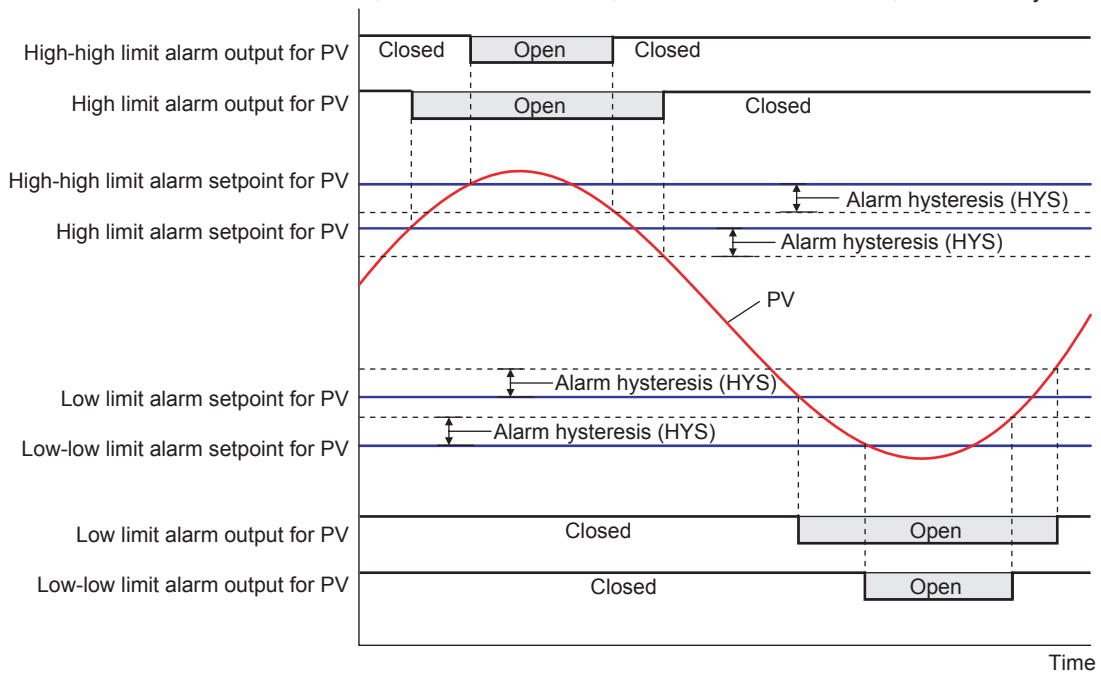

For an example in the figure above, the contact type is such that the contact opens if an event occurs (factory default).

0604E.ai

Setting Details

Parameter	Name	Setting Range	Display Transition and Display Title
ASW1 to ASW6	Alarm output connection	00000000 to 11111111	Tuning Display > Engineering Display > [CONFIG3] (Configuration Display 3)
ANOR1 to ANOR6	Alarm AND/OR selection	AND, OR	
DO1D to DO6D	Alarm contact type	OPN: When the alarm occurs, the contact is opened. CLS: When the alarm occurs, the contact is closed.	

1.4 Setting Alarm Output Hysteresis

Description

Setting hysteresis (differential gap) to alarm action prevents chattering in digital output.

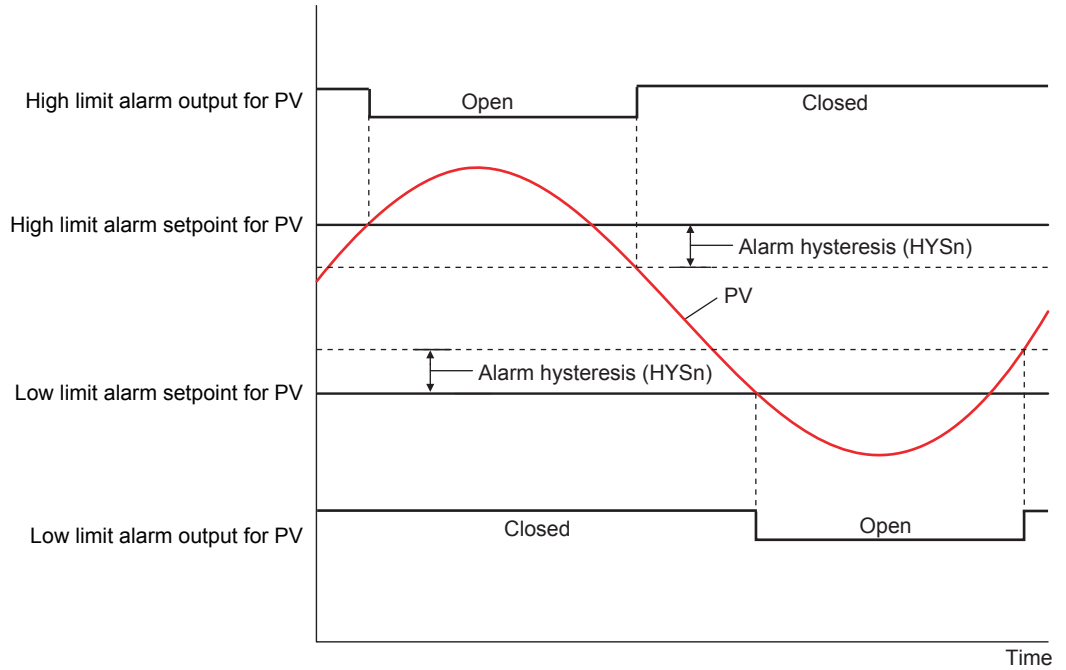

For an example in the figure above, the contact type is such that the contact opens if an event occurs (factory default).

0213E.ai

Setting Details

Parameter	Name	Setting Range	Display Transition and Display Title
HYS1, HYS2	Alarm hysteresis	Equivalent to 0.0 to 20.0% in the engineering unit	Tuning Display > [SETTING1] (Setting Display 1) or [SETTING2] (Setting Display 2)

The HYS2 parameter is used for the loop 2.

1.5 Using Alarm Output 6 as Digital Input (LCD Backlight OFF Input, All Event OFF)

Description

The table below shows the YS1310 digital input/output terminal number and the target parameter.

Terminal Number	Application	Parameter
38 – 39	To be used as DI1 or DO6	DIO16 (DI1/DO6 specification)

If any front panel key is pressed once while the LCD backlight is OFF, it will be turned ON again.

When a digital input signal (DI) is switched from "Close" to "Open", all the displayed events are cleared. For all other cases, events are displayed when the display conditions are met.

After the event display is cleared, if the digital input signal (DI) remains "Open", when an event display condition is met, the corresponding event (1 to 5) is displayed.

(When the contact type is OPN)

Setting Details

Parameter	Name	Setting Range	Display Transition and Display Title
DIO16	DI1/DO6 specification	DI: Used as LCD backlight OFF input DO: Used as alarm output 6	Tuning Display > Engineering Display > [CONFIG3] (Configuration Display 3)
DI1F	DI function selection	NONE: No function assigned LCD-OFF: LCD backlight OFF TR-EVT.C: All event OFF	
DI1D	DI1 contact type	OPN: Function is enabled when the contact is open. CLS: Function is enabled when the contact is closed.	

1.6 Using the Event Function

1.6.1 Displaying Messages (Event Display Function (Settable Only in YSS1000))

Description

The event display function displays a message (in Japanese, English, or Chinese) on the Operation Display if an event such as an abnormality occurs, providing guidance for the operator. A maximum of five events can be set using the YSS1000 Setting Software (sold separately). Events will be displayed on all Operation Displays. The display area is 200 × 80 dots, with 50 × 80 dots of that used to display a clearing guide.

If multiple events occur simultaneously, they are displayed in an overlaid condition. The order of priority is (high) event 1 > 2 > 3 > 4 > 5 (low), and the event with the highest priority is displayed on top. The event being displayed can be cleared by pressing and holding the SHIFT key for three seconds. Moreover, events can be redisplayed on Alarm Display.

- ▶ For how to redisplay events: see "Monitoring and Operating the Alarm Display" in the YS1310 Indicator with Alarm Operation Guide.

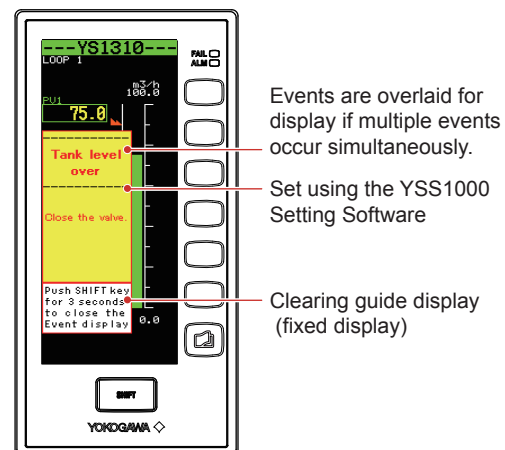

Only foreground event is cleared.

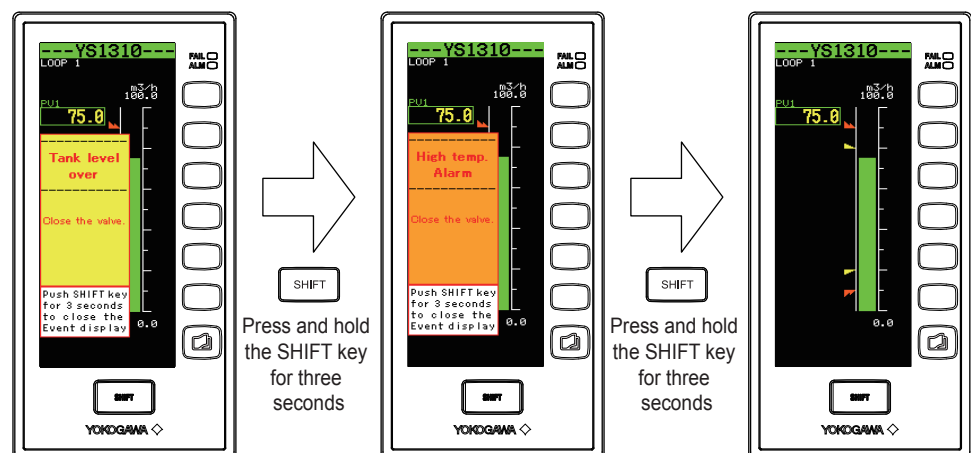

0102E.ai

1.6 Using the Event Function

Event flag

The status register is the flag to indicate an event. An event is displayed if the status register changes from 0 to 1 or from 1 to 0.

Process alarm such as a high limit alarm, operation mode, etc. can be registered as a flag.

Simulation Display

After downloading the event display data from YSS1000, the event can be displayed forcibly. Simulation display can be set when operation is stopped.

To cancel simulation display:

- (1) Turn OFF simulation display on YSS1000.
- (2) Change the operation stop status from stopped to operating.
- (3) Turn the power supply OFF and then ON.

Deletion Guide Display Language

English

Push SHIFT key
for 3 seconds
to close the
Event display

0103E.ai

1.6.2 Changing the PV Bar Display Color in the Event of a Process Alarm (Active Display Function)

Description

The active color display function changes the colors of the PV bar on the LOOP Display to red to inform the operator of instrument abnormality. Active color display can be set on a loop basis and items can be selected from each loop's process alarms (see the table below).

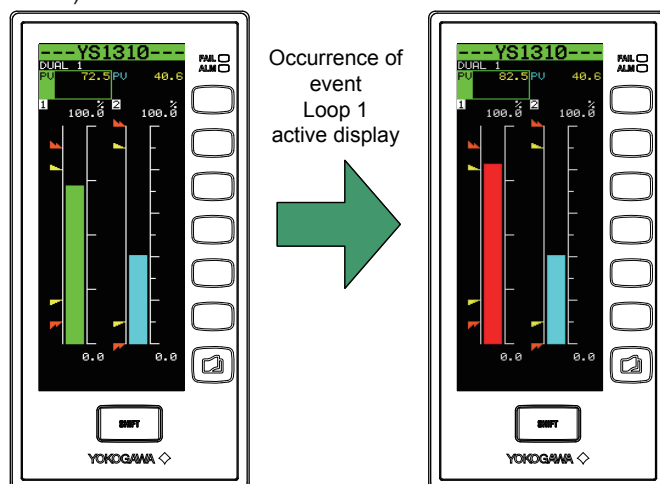

0211E.ai

Setting Details

Parameter	Name	Setting Range	Display Transition and Display Title
ACTD1	Active color display selection 1	OFF: Without active display function (factory default) PH1: High limit alarm setpoint for PV 1 PL1: Low limit alarm setpoint for PV 1 HH1: High-high limit alarm setpoint for PV 1 LL1: Low-low limit alarm setpoint for PV 1 1-ALM: Logical OR of all loop 1 alarms	Tuning Display > Engineering Display > [DISPLAY] (Setting Display for Operation Display)
ACTD2	Active color display selection 2	OFF: Without active display function (factory default) PH2: High limit alarm setpoint for PV 2 PL2: Low limit alarm setpoint for PV 2 HH2: High-high limit alarm setpoint for PV 2 LL2: Low-low limit alarm setpoint for PV 2 2-ALM: Logical OR of all loop 2 alarms	

The ACTD2 parameter is used for the loop 2.

1.6.3 Operator Notification Using Tag Number Display (Alternate Tag Number Color Display Function)

Description

In the event of an ALM lamp lighting, the alternate tag number color display function notifies the operator of instrument abnormality by alternating the color of the tag number background and red.

- ▶ For lighting of ALM lamp: see "How to Take Actions if the ALM Lamp or FAIL Lamp Lights up" in the YS1310 Indicator with Alarm Operation Guide.

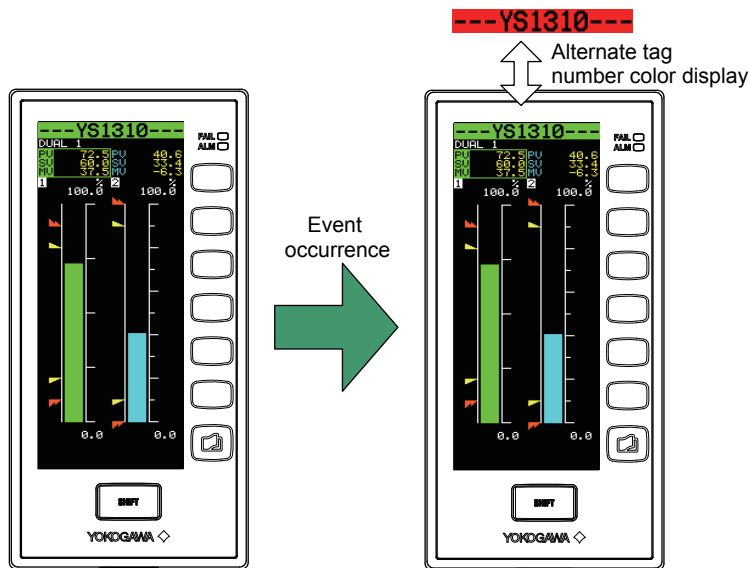

0212E.ai

Setting Details

Parameter	Name	Setting Range	Display Transition and Display Title
TAGAL	Color inversion of tag number	OFF: Disabled (factory default) ON: Enabled	Tuning Display > Engineering Display > [DISPLAY] (Setting Display for Operation Display)

2.1 Display Function

2.1.1 Setting Visible/Invisible Status of the Operation Display

Description

There are nine types of Operation Displays. Displays you chose not to display can be made invisible.

LOOP1 Display is always displayed even if you set "OFF" for all lines.

Operation Display Name	YS1310
LOOP1 (LOOP 1 Display)	✓
LOOP2 (LOOP 2 Display)	✓
MTR1 (METER 1 Display)	✓
MTR2 (METER 2 Display)	✓
TRND1 (TREND 1 Display)	✓
TRND2 (TREND 2 Display)	✓
TRND3 (TREND 3 Display)	✓
ALRM (Alarm Display)	✓
DUAL (DUAL Display)	✓

Legend ✓: Visible

2.1 Display Function

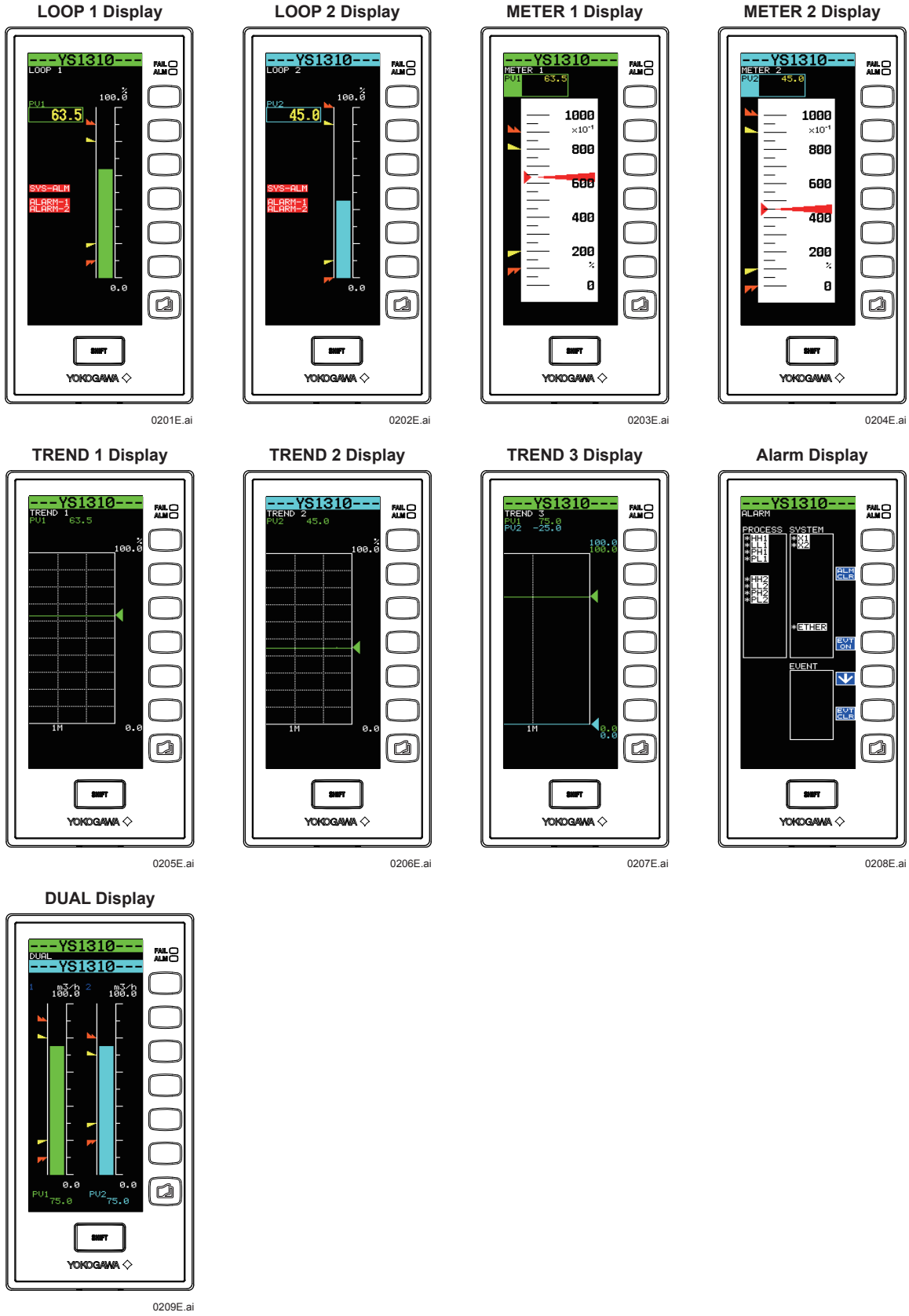

Setting Details

Parameter	Name	Setting Range	Display Transition and Display Title
LOOP1	LOOP 1 Display ON/OFF	OFF: Invisible ON: Visible	Tuning Display > Engineering Display > [CONFIG1] (Configuration Display 1)
LOOP2	LOOP 2 Display ON/OFF		
MTR1	METER 1 Display ON/OFF		
MTR2	METER 2 Display ON/OFF		
TRND1	TREND 1 Display ON/OFF		
TRND2	TREND 2 Display ON/OFF		
TRND3	TREND 3 Display ON/OFF		
ALARM	Alarm Display ON/OFF		
DUAL	DUAL Display ON/OFF		

2.1 Display Function

2.1.2 Setting Visible/Invisible Status of TREND Display Data

Description

PV trend displayed on TREND 1 and TREND 2 Displays can be set to be visible or invisible. It is possible to select the trends that are to be displayed, making only the data necessary to be monitored visible on the Operation Display.

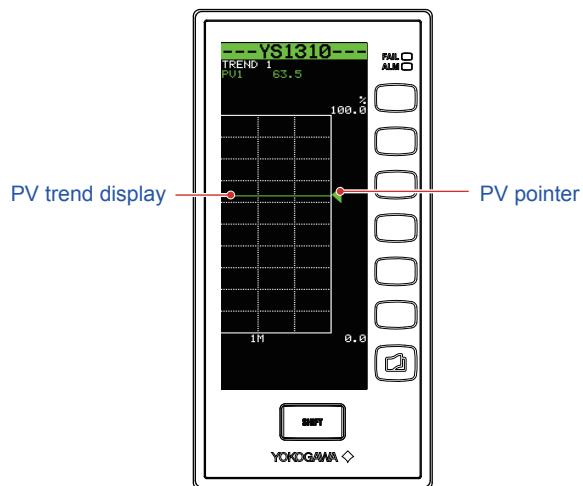

0212E.ai

Setting Details

Parameter	Name	Setting Range	Display Transition and Display Title
TR1PV	PV1 trend ON/OFF for TREND 1 Display	OFF: Invisible ON: Visible	Tuning Display > Engineering Display > [DISPLAY] (Setting Display for Operation Display)
TR2PV	PV2 trend ON/OFF for TREND 2 Display		

The TR2PV parameter is used for loop 2.

2.1.3 Changing the Time Span of TREND Displays

Description

The time span of trends displayed on the TREND 1, TREND 2, and TREND 3 Displays can be set.

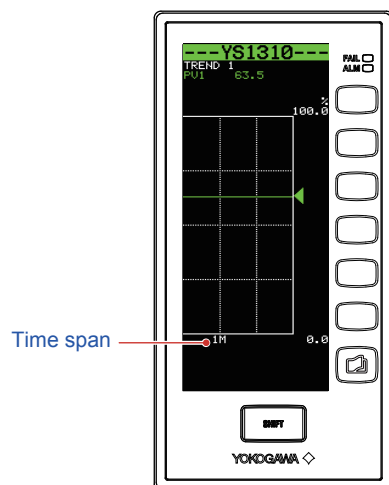

0216E.ai

Setting Details

Parameter	Name	Setting Range	Display Transition and Display Title
TRDT1	TREND 1 Display time span	1M: 1 minute 5M: 5 minutes 10M: 10 minutes	Tuning Display > Engineering Display > [DISPLAY] (Setting Display for Operation Display)
TRDT2	TREND 2 Display time span	30M: 30 minutes 1H: 1 hour	
TRDT3	TREND 3 Display time span	5H: 5 hours 10H: 10 hours 30H: 30 hours	

The TRDT2 parameter is used for loop 2.

2.1 Display Function

2.1.4 Setting Display Data on the TREND 3 Display

Description

Display data shown on the TREND 3 Display can be set arbitrarily. A maximum of four data items can be set. This enables the necessary data to be monitored on the Operation Display.

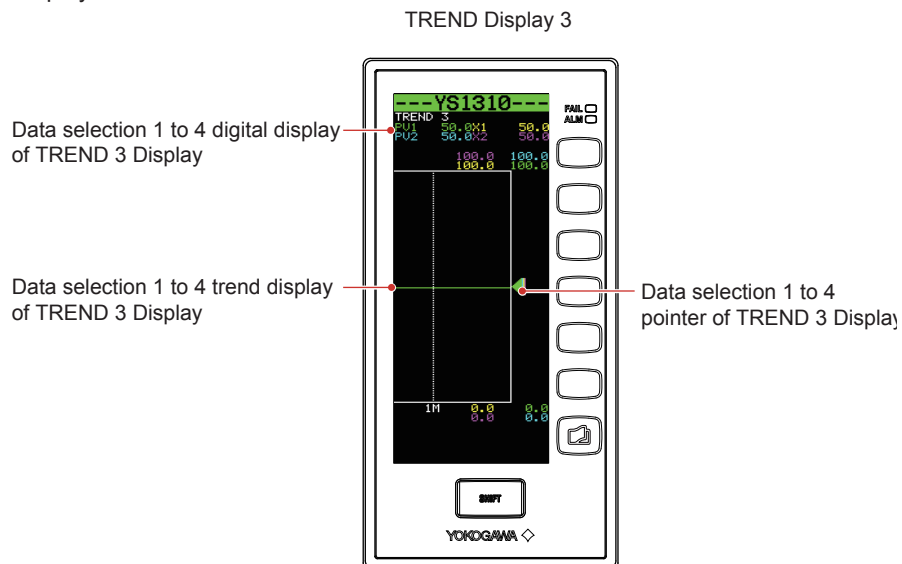

Setting Details

Parameter	Name	Setting Range (*1)	Display Transition and Display Title
TRDS1	Data selection 1 for TREND 3 Display	OFF: No display PV1: Process variable 1 PV2: Process variable 2 X1: Input 1 X2: Input 2	Tuning Display > Engineering Display > [DISPLAY] (Setting Display for Operation Display)
TRDS2	Data selection 2 for TREND 3 Display		
TRDS3	Data selection 3 for TREND 3 Display		
TRDS4	Data selection 4 for TREND 3 Display		

X1 to X2 are values input to or output from the YS1310 terminal block.

2.1.5 Changing Scale Divisions on the LOOP, TREND, and DUAL Displays

Description

The provision of scale divisions is relevant to the LOOP, TREND, and DUAL Displays. For scale divisions on the METER Displays, see [2.1.6 Automatic Scale Divisions/Making Scale Values More Legible on the METER Displays](#)

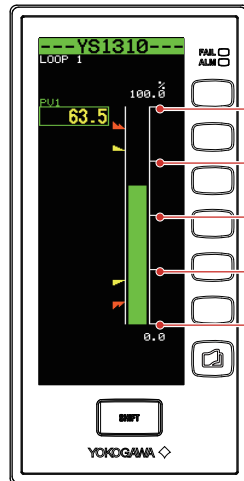

Scale division
The figure on the left is an example of four scale divisions.

0214E.ai

Setting Details

Parameter	Name	Setting Range	Display Transition and Display Title
SCDV1	Scale division 1	1, 2, 4, 5, 7, 10, 14, 20	Tuning Display > Engineering Display >
SCDV2	Scale division 2		[CONFIG2] (Configuration Display 2)

The SCDV2 parameter is used for loop 2.

2.1 Display Function

2.1.6 Automatic Scale Divisions/Making Scale Values More Legible on the METER Display

Description

For scales on the METER Displays, scale divisions are automatically provided based on the values set to the scale between 0% and 100% values.

The number of scale divisions is from a minimum of 11 divisions to a maximum of 20 divisions.

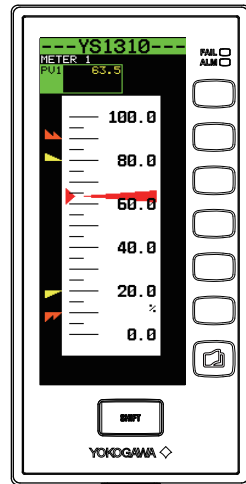

0215E.ai

Scale numbers displayed on the METER Display are also automatically determined from the scale's 0% to 100% values in the same way as the scale divisions. To improve the legibility of the scale numbers, they can be displayed to the power of 10.

Setting Details

Parameter	Name	Setting Range	Display Transition and Display Title
MTMG1	10-exponential scale factor for METER 1 Display	AUTO, 10 ⁻⁵ , 10 ⁻⁴ , 10 ⁻³ , 10 ⁻² , 10 ⁻¹ , 10 ⁰ ,	Tuning Display > Engineering Display >
MTMG2	10-exponential scale factor for METER 2 Display	10 ¹ , 10 ² , 10 ³ , 10 ⁴ , 10 ⁵ ,	[DISPLAY] (Setting Display for Operation Display)

The MTMG2 parameter is used for loop 2.

2.1.7 Selecting the Operation Display to be Displayed First at Power ON

Description

The Operation Display to be displayed first when the power is turned ON can be set. The figure below shows an example of displaying the TREND 1 Display first.

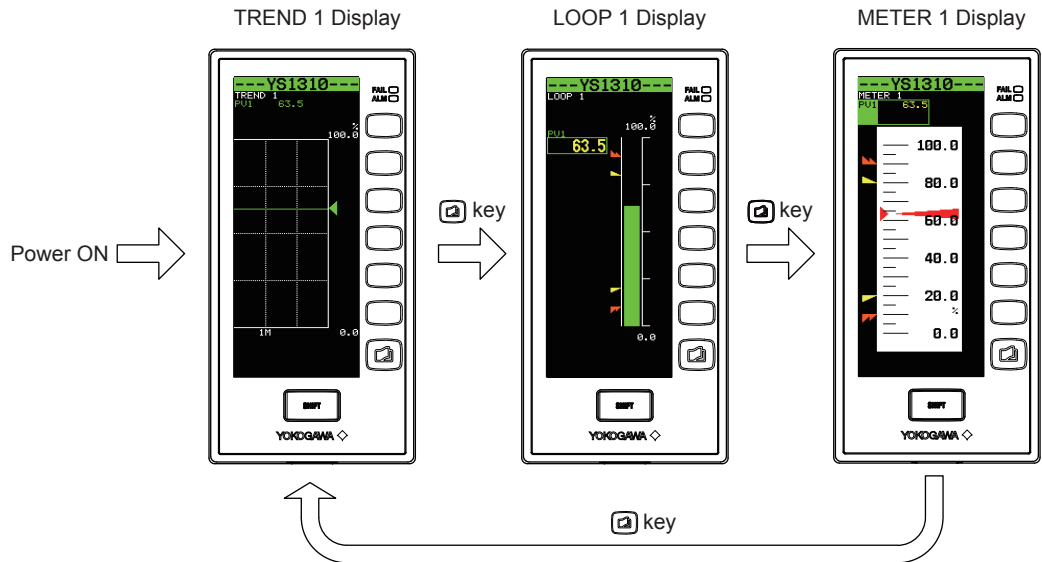

0416E.ai

Setting Details

Parameter	Name	Setting Range	Display Transition and Display Title
FDSP	Power-on initial display	LOOP1: LOOP 1 Display LOOP2: LOOP 2 Display MTR1: METER 1 Display MTR2: METER 2 Display TRND1: TREND 1 Display TRND2: TREND 2 Display TRND3: TREND 3 Display ALARM: ALARM Display DUAL: DUAL Display	Tuning Display > Engineering Display > [CONFIG1] (Configuration Display 1)

2.1.8 Turning the LCD Backlight ON/OFF

Description

The backlight auto-off function makes it possible to turn off the LCD backlight in cases where the YS1000 is installed in locations where the display is not usually seen or if it desired to turn it off at night. This is an energy-saving feature that extends the life of the display unit.

The LCD backlight can be turned ON/OFF using the following means:

- (1)Front panel keys
- (2)OFF timer setting
- (3)Digital input
- (4)Communication

There is no priority order to the methods (1) to (4). The backlight OFF function retains the status effected when the LCD was operated last.

Note that if the FAIL or ALM lamps are lit, or if an event is displayed, the backlight will light up even if the backlight has been set to OFF.

- (1)Front panel key

If any key is pressed once while the LCD backlight is OFF, it will be turned ON.

However, it cannot be turned OFF by keystrokes. To set the backlight condition to OFF using keystrokes, employ method (2).

- (2)OFF timer setting

With the LCD backlight auto-off timer turned ON, the LCD backlight will be turned OFF when there has been no keystroke operation for 30 minutes.

- (3)Digital input

If digital input to which the backlight OFF function has been assigned changes from open to close status, the backlight is turned OFF. If it changes from close to open status, the backlight is turned ON.

► For assigning the backlight OFF function to digital input: see Chapter 1, Input/output and Auxiliary Functions, in this manual.

- (4)Communication

The LCD backlight ON/OFF condition can be checked and set using a CFL flag (communication register). Write "0" or "1" to the CFL flag through communication to (0) to turn the backlight ON or to (1) to turn it OFF.

► For backlight OFF function through communication: see YS1000 Series Communication Interface User's Manual.

Setting Details

Parameter	Name	Setting Range	Display Transition and Display Title
ECO	LCD backlight auto-off timer	OFF: Timer function OFF ON : Timer function ON (Off timer: 30 min)	Tuning Display > Engineering Display > [LCD] (LCD Setting Display)

2.1.9 Changing the Background and Loop Colors

Description

The background color of the Operation Display, and the color of the PV bars of the LOOP Displays and the DUAL Display can be changed. Setting the Operation Display's background color to black causes the color of the lettering to be white; setting the background color to white causes the color of the lettering to be black.

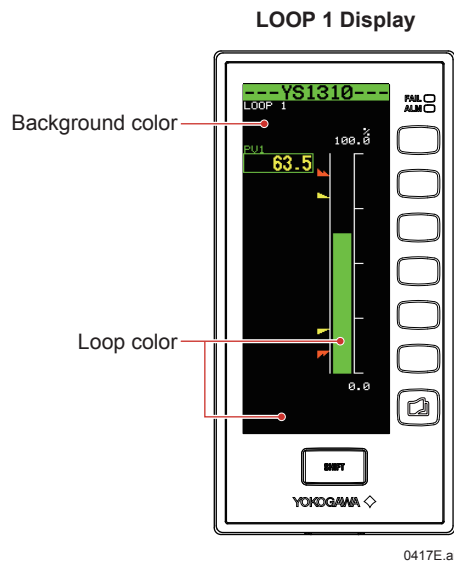

0417E.ai

Setting Details

Parameter	Name	Setting Range	Display Transition and Display Title
BKCL	Background color selection	BLACK WHITE BLUE	Tuning Display > Engineering Display > [DISPLAY] (Setting Display for Operation Display)
LP1C	LOOP 1 color selection	GREEN AQUA PINK ORANGE	
LP2C	LOOP 2 color selection		

The LP2C parameter is used for loop 2.

2.1.10 Adjusting LCD Brightness

Description

The brightness of the LCD can be adjusted.
 The adjustment bar display shows brightness adjustment values in bar format to indicate the current value with respect to the settable range.

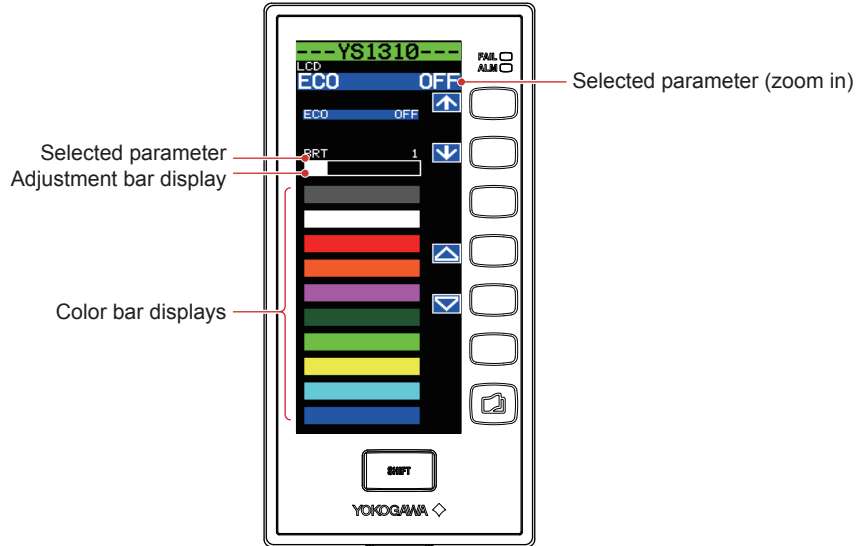

0227E.ai

Setting Details

Parameter	Name	Setting Range	Display Transition and Display Title
BRT	LCD brightness adjustment	0 to 5	Tuning Display > Engineering Display > [LCD] (LCD Setting Display)

2.2 Security Function

2.2.1 Inhibiting/Enabling Parameter Change

Description

Setpoints for the tuning parameters or engineering parameters can be locked to prevent them from being inadvertently changed. When they are locked, the parameter setting increase key Δ and decrease key ∇ displays are erased from each setting display. The password for locking them is a 4-digit numeral, which is not set at factory shipment. When the password is not set or is cleared, [SET PASSWORD] and [UNLOCK] are displayed. When the password is set, [ENT PASSWORD] and [LOCK] are displayed.

Software key function

The software key function enables the front panel's operation keys to function as keys displayed on the LCD display.

- [SET] software key: Password setting key
Press this key to set a password.
- [ENT] software key: Password entry/cancellation key
Press this key to cancel the password setting.
- [→] key: Cursor movement key
Moves the cursor position to the right when setting or entering a password.
- Δ software key: Number increase key
Increases numbers. Numbers change from 0 to 9 cyclically.
- ∇ software key: Number decrease key
Decreases numbers. Numbers change from 0 to 9 cyclically.

Operating the Password Setting Display

1. Setting a password (setting a password to prevent parameter changes)
 - (1) Open the Password Setting Display. [SET PASSWORD] and [UNLOCK] are displayed.
 - (2) Press the [SET] software key. This causes the password [0000] to appear.
 - (3) Using the [→] software key (digit movement) and the Δ (increase) or ∇ (decrease) software keys, set the password.
 - (4) Press the [SET] software key. This changes the password background color.
 - (5) Press the [SET] software key again. This erases the password, causing [ENT PASSWORD] and [LOCK] to appear. At the instant the password is set, the [SET] software key display is erased, replaced by the [ENT] software key instead.
2. Entering/canceling a password (entering a password to the instrument to which the password has been set, to enable parameter changes)
 - (1) Open the Password Setting Display. [ENT PASSWORD] and [LOCK] are displayed.
 - (2) Press the [ENT] software key. This causes the password [0000] to appear.
 - (3) Using the [→] software key (digit movement) and the Δ (increase) or ∇ (decrease) software keys, enter the password that has been set.
 - (4) Press the [ENT] software key. This changes the password background color.
 - (5) Press the [ENT] software key again. This erases the password if the password entered agrees with the one that was set, causing [SET PASSWORD] and [UNLOCK] to appear. This brings about a status allowing parameters to be changed. If the password entered does not agree with the one that has been set, return to step (3).

2.2 Security Function

Setting/Entry Display

Operation Display > [SHIFT] + [] keys (to the Tuning Menu Display) > [SHIFT] + [] keys (to the Engineering Menu Display) > [PASSWORD] software key (Password Setting Display)

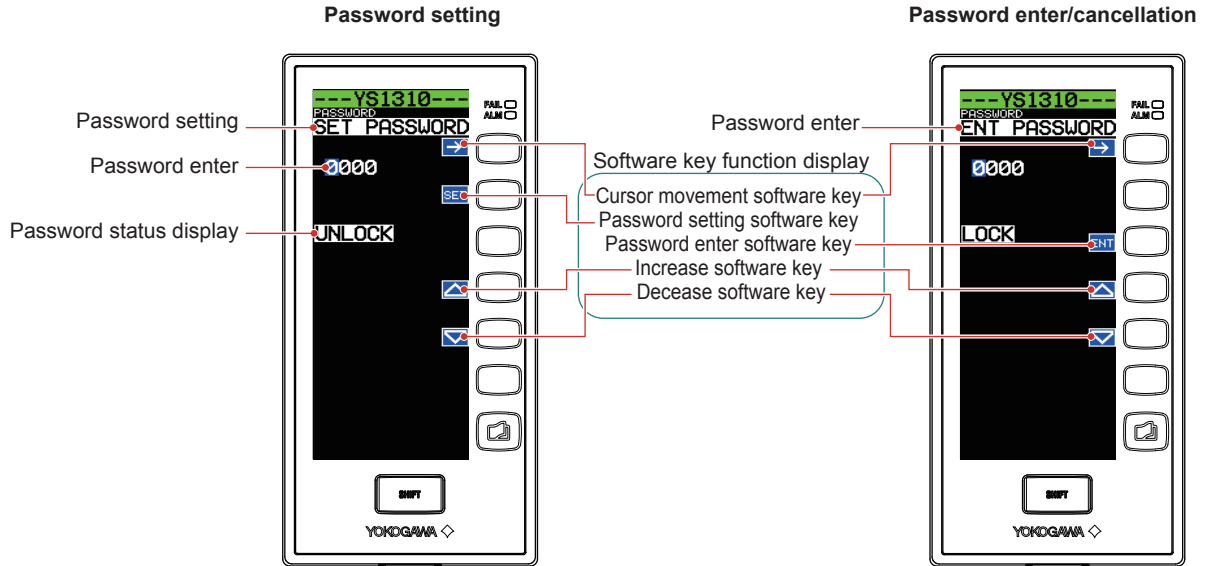

0420E.ai

3.1 List of Direct Input Specifications and Basic Operations

In the SC Setting Display, communication with the direct input cards, optional specifications, is made to set or adjust the input specifications.

Examples of sensor type setting, burnout setting, input zero adjustment, and span adjustment procedures are described in sections 3.2 to 3.4. Other items are also set in the same way. The table below shows a list of setting items.

No.	Name Display	Description	Model-basis Data Display				
			/A01	/A02	/A03	/A04	/A08
01	MODEL	Model	EM1°C	ET5°C	ER5°C	ES1°C	EP3*A
02	TAG NO.	Tag number	16 alphanumeric characters				
03	SELF CHK	Self-check results	GOOD or ERROR				
A00	DISPLAY	Display item	--	--	--	--	--
A01	INPUT	Input value	[][]-[][]mV	[][][]-[][]degC	[][][]-[][]degC	[][][][][]-[][] OHM	[][][][]Hz
A02	OUTPUT	Output value	[][][]-[][]%				
A03	STATUS	Status	FF				
A04	REV NO.	Revision number	n.000 (n: Revision number)				
B00	SET	Setting item	--	--	--	--	--
B01	TAG NO1	Tag number 1	8 alphanumeric characters (8 first-half characters of a tag number)				
B02	TAG NO2	Tag number 2	8 alphanumeric characters (8 latter half characters of a tag number)				
B03	COMMENT1	Comment 1	8 alphanumeric characters (8 first-half characters of comment)				
B04	COMMENT2	Comment 2	8 alphanumeric characters (8 latter half characters of comment)				
B05	INP TYPE	ER5 input type	--	--	PT/JPT/ PT100-90/ PT50 (Note 1)	--	--
B06	INP TYPE	ET5 input type	--	B/E/J/K/T/R/S/N	--	--	--
B07	LOW CUT	Low cutoff	--	--	--	--	[][][][]Hz (Note 5)
B08	RESIST	ES1 total resistance	--	--	--	[][][][][]-[][] OHM	--
B09	UNIT	Temperature unit (Note 8)	--	degC/degF/K	degC/degF/K	--	--
B10	ZERO	Zero point	[][][]-[][][]mV	[][][][]-[][][]degC	[][][][]-[][][]degC	[][][][][][]-[][][] OHM	[][][][][]Hz (Note 5)
B11	SPAN	Span (Note 2)	[][][][]-[][][][]mV	[][][][][]-[][][][]degC	[][][][][]-[][][][]degC	[][][][][][][]-[][][][] OHM (Note 4)	[][][][][][]Hz (Note 5)
B12	BURN OUT	Burnout	OFF/UP/DOWN	OFF/UP/DOWN	OFF/UP/DOWN	OFF/UP/DOWN	--
C00	ADJUST	Adjustment item	--	--	--	--	--
C01	OUT 0%	0% output correction (Note 7)	±10.00				
C02	OUT 100%	100% output correction (Note 7)	±10.00				
C03	WIRING R	Burnout correction (Note 3)	EXECUTE/RESET	EXECUTE/RESET	--	--	--
C04	ZERO ADJ	Input zero adjustment (Note 6)	[][][][]-[][][][]mV RST/INC/DEC	[][][][][]-[][][][][]mV RST/INC/DEC	[][][][][][]-[][][][][] OHM RST/INC/DEC	--	--
C05	SPAN ADJ	Input span adjustment (Note 6)	[][][][][]-[][][][][]mV RST/INC/DEC	[][][][][][]-[][][][][][]mV RST/INC/DEC	[][][][][][][]-[][][][][][] OHM RST/INC/DEC	--	--
C06	ZERO ADJ	Input zero adjustment (Note 6)	--	--	--	[][][][][]-[][][][] OHM	--
C07	SPAN ADJ	Input span adjustment (Note 6)	--	--	--	[][][][][][]-[][][][][] OHM	--

3.1 List of Direct Input Specifications and Basic Operations

- Note 1: PT=Pt100 (IPtS-68: JIS'89), JPT=JPt100 (JIS'89), PT100-90=Pt100 (ITS-90: JIS'97), PT50=Pt50 (JIS'81)
- Note 2: Measurable data is within the range stated in the standard specifications.
- Note 3: Burnout correction is the function of correcting an error caused by the burnout current produced if an external conductor resistance is large.
- Note 4: Up to 30 k Ω is possible, but the standard specifications indicate 100 to 2000 Ω in.
- Note 5: Set in four significant digits or less. However, 10000 Hz can be set for span.
- Note 6: Input zero adjustment and input span adjustment are to make input adjustments of each direct input card. /A01, /A02, and /A03 enable the adjustment of the offset and gain of the A/D converter. Select [INC] or [DEC] using the Δ or ∇ software keys and press the [ENT] software key twice to make an adjustment for each selection. Also, to reset adjustments select [RST] and press the [ENT] software key twice. Zero and span are re-set in /A04. In other words, making a zero adjustment with an input set to 0% and a span adjustment with the input set to 100% (pressing the [ENT] software key twice) causes the zero (B10) and span (B11) values to be re-set automatically.
- Note 7: Output correction is for adjusting the D/A converter (1 to 5 V output) of each direct input card. 0% output correction and 100% output correction enable offset and gain to be adjusted respectively. Set a value in the range of $\pm 10.00\%$ and press the [ENT] software key twice. This causes the D/A converter to enter a status in which the set value-added 0% output value or the 100% output value is continuously output. To exit this status, display another parameter once on the SC Setting Display, or turn the power supply OFF and then ON.
- Note 8: If optional code /DF is specified, Fahrenheit temperature range can be used for direct input range in addition to centigrade temperature range.

Basic Operations

- 1) Erroneous setting prevention function
To prevent inadvertent operation, no parameter is selected (highlight displayed) immediately after switching to the SC Setting Display. Press the \rightarrow software key to select parameter [SET] (parameter setting enable/disable) from the top line of the display.
- 2) Setting-enable parameter operation
[SET] on the top line is the parameter for enabling SC maintenance communication. This parameter is in [INHB] (setting inhibited) immediately after switching to the SC Setting Display. SC maintenance communication cannot be accomplished unless this parameter is set to [ENBL] (setting enabled). To do so, select the [SET] parameter and then press the Δ software key to change the setting from [INHB] to [ENBL]. At the same time, [STOP] appears at the upper right of the display. Moreover, switching to another display causes this parameter to return to [INHB] automatically.
- 3) Software keys
 - [MNU] software key: Menu change key
Each time this key is pressed, YS1310 communicates with the SC to read out and display the SC menus.
 - [PRM] software key: Setting item change key
Each time this key is pressed, YS1310 communicates with the SC to read out and display the SC setting items.
 - \rightarrow software key: Cursor movement key
When the data type is alphanumeric characters, this key moves an highlight displayed digit to the right. In this case, should the highlight display be at the rightmost digit, it then moves to the leftmost digit.
 - Δ software key: Data increase key
Increases data. Data changes cyclically.
 - ∇ software key: Data decrease key
Decreases data. Data changes cyclically.
 - [ENT] software key: Enter key
Writes data to the SC. Writing is done in the following two steps:
(1) Press the [ENT] software key. This causes the background color of all communication data to be highlight displayed.

3.1 List of Direct Input Specifications and Basic Operations

(2) Press the [ENT] software key again. This writes the data to the SC card, causing the display to return to normal display. If any key other than the [ENT] software key is pressed, the communication data returns to normal display without being written to the SC.

4) SC setting operation

- SC setting is made as follows:

(1) Selecting the SC menu

Press the [MNU] software key to read out and display the SC menus. Each time the [MNU] software key is pressed, the model, tag number, and self-check results are displayed in turn. Further pressing the [MNU] key causes the display item, setting item, and adjustment items to be changed and displayed cyclically.

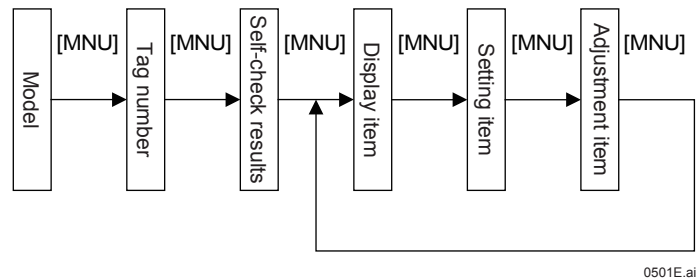

(2) To select the display item, setting item, or adjustment item, further select a setting item.

Press the [PRM] software key to read out and display the SC setting item. Each time the [PRM] software key is pressed, the setting items are displayed in turn. The parameters to be displayed change depending on the SC card; see the items in the list of displayed items. Press the [PRM] software key until the setting item you wish to set appears.

- (3) Using the [→] software key (cursor movement) and the [△] (data increase) or [▽] (data decrease) software keys, set the setting item.
- (4) Press the [ENT] software key. This causes the setting item to be highlight displayed.
- (5) Press the [ENT] software key again. This writes data to the SC card, causing the display to return to the normal display. Pressing any key other than the [ENT] software key causes the display to return to the normal display without writing data.

Communication Status Display

Comment Display	Status
COMMUNICATING	Communicating with an SC card (normal communication)
COMMUN. ERR	Communications error
OPERATION ERR	Incorrect data sending
COMMAND ERR	Incorrect command reception

3.2 Setting Sensor Type

Description

The sensor type can be set as for thermocouple and RTD cards.

Setting Details

Operation Display > [SHIFT] + [] keys (to the Tuning Menu Display) > [SHIFT] + [] keys (to the Engineering Menu Display) > [SC MAINT] software key (Input Specification Setting Display)

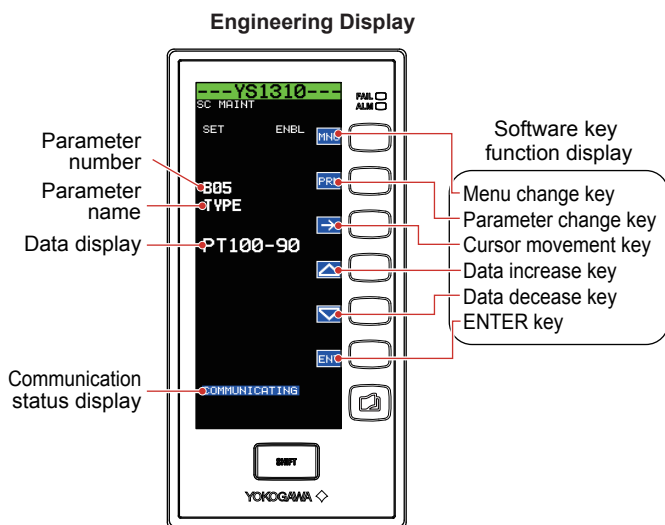

Setting Procedure

(example of setting an RTD type)

- (1) Press the [→] software key to display [SET INHB] in highlight.
- (2) Press the [△] software key to display [SET ENBL].
- (3) Press the [MNU] software key to display
01
MODEL
Directly input the card model (e.g., ER5°C)
- (4) Press the [MNU] key several times to display
B00
SET
- (5) Press the [PRM] software key several times to display the left display.
- (6) Press the [△] or [▽] software keys to change the data display section.
- (7) Press the [ENT] software key to display the data display section in highlight.
- (8) Press the [ENT] software key again to accept the setting.

Setting completed.

0502E.ai

3.3 Setting Burnout

Description

A burnout can be set as for mV input, thermocouple, RTD, and potentiometer input cards.

Setting Details

Operation Display > **[SHIFT]**+**[F1]** keys (to the Tuning Menu Display) > **[SHIFT]**+**[F1]** keys (to the Engineering Menu Display) > **[SC MAINT]** software key (Input Specification Setting Display)

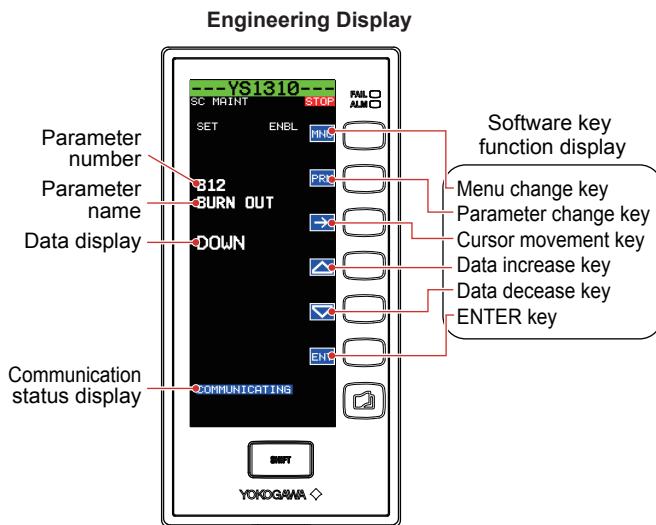

Setting Procedure

(example of setting to RTD inputs)

- (1) Press the [→] software key to display [SET INHB] in highlight.
- (2) Press the [△] software key to display [SET ENBL].
- (3) Press the [MNU] software key to display
 01
 MODEL
 Directly input the card model (e.g., ER5°C)
- (4) Press the [MNU] software key several times to display
 B00
 SET
- (5) Press the [PRM] software key several times to display the left display.
- (6) Press the [△] or [▽] software key to change the data display section.
- (7) Press the [ENT] software key to display the data display section in highlight.
- (8) Press the [ENT] software key again to accept the setting.

Setting completed.

3.4 Making Zero and Span Adjustments of Input

Description

Zero and span adjustments of inputs can be set as for mV input, thermocouple, and RTD cards.

Setting Details

Operation Display > [SHIFT] + [ENT] keys (to the Tuning Menu Display) > [SHIFT] + [ENT] keys (to the Engineering Menu Display) > [SC MAINT] software key (Input Specification Setting Display)

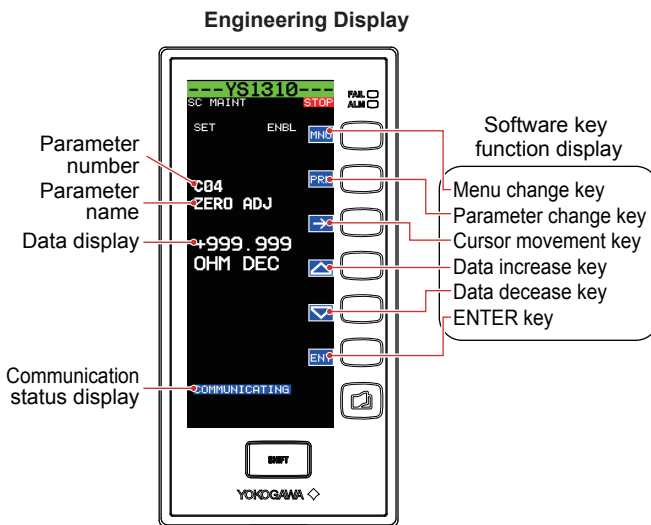

Setting Procedure

- (1) Press the [→] software key to display [SET INHB] in highlight.
- (2) Press the [△] software key to display [SET ENBL].
- (3) Press the [MNU] software key to display
01
MODEL
Directly input the card model (e.g., ER5°C)
- (4) Press the [MNU] key several times to display
C00
ADJUST
- (5) Press the [PRM] software key several times to display the left display.
- (6) Press the [△] or [▽] software keys to change the data display section.
- (7) Press the [ENT] software key to display the data display section in highlight.
- (8) Press the [ENT] software key again to accept the setting.

Setting completed.

0504E.ai

4.1 Processing during Power Failures

Description

YS1310 enters a power failure status if a momentary power interruption of about 20 ms occurs in the case of 100 V AC supply voltage, or if that of 1 ms or more occurs in the case of 24 V DC. The operation to be taken after power is restored can be set.

Data storage

YS1310 data can be stored by making a setting with keystrokes or by making a setting using communication through YSS1000 Setting Software. Data to be stored are the setting parameters, event display data. Trend data displayed on a TREND Display will be lost in the event of a power failure.

Operation after power restoration

The operation to be taken after power restoration depends on the duration of the power failure and the operation mode that the YS1310 is in after power restoration (Start mode (START), engineering parameter).

Start Mode (START)	Power Failure Duration	
	Less than about 2 seconds	About 2 seconds or more
AUT	HOT start	
COLD	HOT start	COLD start

Operation in Each Start Mode

	Start Mode (START)	
	HOT Start	COLD Start
First-order lag dead time	Continued as is	Initialization
Process alarms, and system alarms	Continued as is	OFF
DO1 to DO6	Continued as is	OFF

4.1 Processing during Power Failures

Power Failure Duration and Operation in Each Start Mode

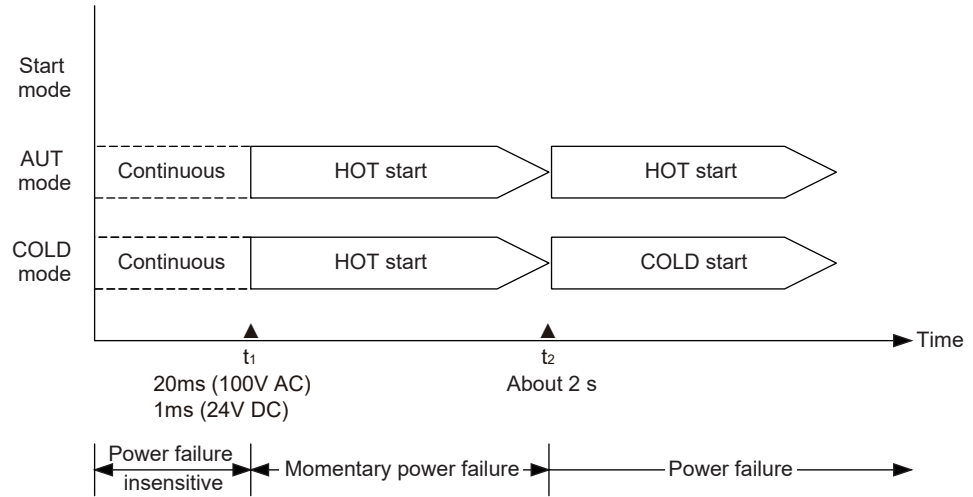

- [Failure insensitive region (power failure duration < t_1)] : t_1 = about 1 ms (for 24 V DC type)
: t_1 = about 20 ms (for 100 V AC type)
YS1000 performs the same operation as that of continuity status.
- [Momentary failure region (t_1 < power failure duration < t_2)] : t_2 = about 2 s
The instrument stops operation during power failure.
- [Power failure region (t_2 < power failure duration)]:
The instrument stops operation during power failure.

0401E.ai

Setting Details

Parameter	Name	Setting Range	Display Transition and Display Title
START	Start mode	AUT: HOT start COLD: Power failure duration < 2 sec. ; HOT start, Power failure duration \geq 2 sec. ; COLD start	Tuning Display > Engineering Display > [CONFIG1] (Configuration Display 1)



WARNING

For products with optional code /FM or /CSA:

- (1) Devices must be maintained by professionally trained personnel or ask YOKOGAWA's sales office or sales representative.
- (2) In case of option code /FM, install devices according to NEC (National Electrical Code: ANSI/NFPA-70).
In case of option code /CSA, all wiring shall comply with Canadian Electrical Code Part I and local electrical codes.

CAUTION

If the instrument's front panel becomes soiled or dusty, wipe it gently using a dry, soft cloth. Do not use organic solvents, chemicals, or chemically treated dust cloths. Doing so may result in the instrument case becoming deformed or discolored.

5.1 Inspecting Indication Accuracy

As a guideline, indication accuracy should be inspected on an annual basis.

5.1.1 Calibration Instruments

Name	Description	Number of Units
DC voltage standard	Yokogawa 7651 or equivalent	1
Digital multimeter	Yokogawa 7561 or equivalent	1

5.1.2 Inspecting Input Indication Accuracy

Follow the procedure below to specifically check input indication accuracy.

- (1) Apply a voltage of 1.0 V DC to the analog input terminals using the voltage standard.
- (2) On the Input and Output Data Display of the Tuning Display, check that the analog input signal concerned is equivalent to $0 \pm 0.1\%$ in the engineering unit.
- (3) Similarly, apply a voltage of 5.0 V DC to check that the analog input signal concerned is equivalent to $100 \pm 0.1\%$ in the engineering unit.

Parameter	Name	Display Range	Display Transition and Display Title
X1	Analog input 1	-25.0 to 125.0	Tuning Display > [I/O DATA]
X2	Analog input 2	-25.0 to 125.0	(Input and Output Data Display)

5.2 Recommended Part Replacement Period

The following shows the replaceable part of the YS1310 and the recommended replacement period.

Replaceable Part	Recommended Replacement Period
LCD Display Assembly	About 8 years

WARNING

Part replacement should be carried out by a YOKOGAWA engineer or by YOKOGAWA-approved personnel, as safety standard inspection is required. Contact YOKOGAWA's sales office or sales representative when replacing the parts.

CAUTION

Notes regarding parts with finite life spans

- (1) Parts with finite life spans refer to those in which the abrasion or failure period is expected to be reached within 10 years under normal operating or storage conditions. Therefore, parts with life spans of more than 10 years in terms of design are not mentioned here.
 - (2) The recommended replacement period establishes the period at which preventive maintenance is to be conducted on parts with finite life spans. It does not constitute assurance against incidental failure.
 - (3) The recommended replacement period is only a guideline and differs depending on operating conditions.
 - (4) The recommended replacement period may be changed according to field records, etc.
-

5.3 Packaging when Shipping the Product for Repair

Should the instrument break down and need to be shipped to our sales representative for repair, handle it as noted below:

WARNING

Prior to shipping the instrument, put it into an antistatic bag and repackage it using the original internal packaging materials and packaging container.

6.1 General Specifications



WARNING

This instrument is for Measurement Category O (other). Do not use it for measurements in locations falling under Measurement Categories II, III, and IV.

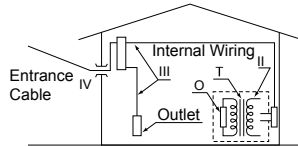

Measurement Category	Description	Remarks
O (other)	For measurements performed on circuits not directly connected to MAINS.	
II CAT.II	For measurements performed on circuits directly connected to the low voltage installation.	Appliances, portable equipments, etc.
III CAT.III	For measurements performed in the building installation.	Distribution board, circuit breaker, etc.
IV CAT.IV	For measurements performed at the source of the low-voltage installation.	Overhead wire, cable systems, etc.

Input and Output Signals

Analog input signals (Measurement Category O (other))

Rated voltage to earth of measuring circuit terminal: 33 VACrms (50/60 Hz) or 70 V DC

Item	YS1310
1 to 5 V DC (basic type)	5 points
Direct input (*1) (optional specifications)	One out of the above number of points can be used.
Input Resistance	1 MΩ

*1: One of mV, thermocouple, RTD, potentiometers, two-wire transmitters, input isolators, or frequency inputs
For the details of direct input, refer to "Direct Input Specification."

Digital inputs

Item	YS1310
Digital input	1 point (shared by alarm output 6)

Input Signal	ON	OFF
For no-voltage contact (*1) (*2)	Closed Resistance: 200 Ω or less	Open Resistance: 100 kΩ or more
For voltage contact (*2)	LOW Input voltage: -0.5 to 1 V DC	HIGH Input voltage: 4.5 to 30 V DC

*1: Input contact rating: 5 V DC, 20 mA or more
Minimum pulse width: 120 ms
*2: No-voltage contacts and voltage contacts may be received at the same terminals.

6.1 General Specifications

Digital outputs

Item	YS1310
Alarm output	6 points (shared by digital input)
Transistor contact	Rating 30 V DC, 200 mA or less (resistive load)
FAIL output (*1)	1 point
Transistor contact	Rating 30 V DC, 200 mA or less (resistive load)

*1: FAIL contact output enters the OFF status at power OFF or failure.
For contact action (ON in normal condition), it is normally closed.

Isolation of Signals from Each Other

Item	YS1310
Analog input signal	Not isolated from the computation control circuit. Signals are not isolated from each other. The negative line is shared. Isolated from other input and output signals.
Direct input	With the exception of 2-wire transmitters (not isolated), input signals are isolated from the computation control circuit. Isolated from the power supply circuit, and other input and output signals.
Digital input and output signal	Isolated from the computation control circuit, between the signals, and from other input and output signals
FAIL signal	Isolated from the computation control circuit and from other input and output signals
Communication	Isolated from the computation control circuit and from other input and output signals
Power supply	Isolated from the computation control circuit and from other input and output signals
Grounding	Isolated from the computation control circuit and from other input and output signals

Transmitter Power Supply

Item	Specifications
Output voltage	25 to 25.5 V DC
Load	60 mA or less (30 mA or less if there is direct input)
Short-circuit protection	80 mA \pm 10 mA
Others	No effect on the computation control circuit if a short circuit occurs. Not isolated from the computation circuit. An external resistor for 1–5 V conversion (250 Ω) should be provided.

Communication Signal Specifications

Item	Programmer Communication (Used for YSS1000)	RS-485 Communication	Ethernet Communication
Electrical Specifications	Complies with RS-232C	Complies with EIA RS-485	Complies with IEEE 802.3 10BASE-T/100BASE-TX
Connection	Dedicated front panel connector	Rear panel screw terminals (Five terminals and the grounding terminal)	Back panel RJ45 connector
Number connectable instruments	1 unit	Maximum of 31 units/port	Up to 4-tier cascade stack (10BASE-T) Up to 2-tier stack (100BASE-TX) (*1) Number of connection: 2 Maximum number of transactions: 1 (*3)
Applicable cable	Dedicated cable A1053UR (USB/RS-232C conversion cable)	Shielded twisted-pair cable Wire size: 0.5 to 1.25 mm ² (AWG No. 20 to 16)	10BASE-T/100BASE-TX cable
Cable length	About 2.7 m	Up to 1200m (1.25 mm ²)	100 m (*2)

*1: Number of cascade connected hubs

*2: Maximum segment length (length between hub and YS1310)

*3: Per a connection

6.1 General Specifications

Operating Conditions

● Normal operating conditions, transport and storage conditions

Item	Normal Operation	Transport and Storage
Ambient temperature	0 to 50°C	-20 to 60°C
Ambient humidity	5 to 90% RH (No condensation)	5 to 95% RH (No condensation)
Power Supply voltage (AC) (*1)	80 to 138 V AC (100 V AC and 24 V AC common power supply) 138 to 264 V AC (220 V AC power supply)	-
Power supply frequency (AC)	50/60 Hz ±3Hz	-
Power Supply voltage (DC) (*1)	20 to 132 V DC (100 V AC and 24 V DC common power supply) 120 to 340 V DC (220 V AC power supply)	-
Continuous vibration	5 to 14 Hz, amplitude : 0.625 mm or less 14 to 150 Hz, 4.9 m/s ² or less, orthogonal three-directional, with 2 hours each	
Short-time vibration	14.7 m/s ² , 15 s or less	
Shock	49 m/s ² (5 G) or less 11 ms or less	
Package drop	Within 1 m	
Magnetic field	400 A/m or less	
Hazardous gas	There shall be no corrosive gas in the location.	
Installation altitude	2000 m above the sea or less	
Atmospheric pressure	86 k to 106 kPa	

*1: Safety standards, FM and CSA non-incendive standard compliant conditions apply at the following rated power supply.

Rated power supply: use of both AC and DC

100 V AC and 24 V DC common power supply

DC drive: 24 - 120 V DC (±10%), no polarity, 750 mA MAX.

AC drive: 100 - 120 V AC (±10%), 50/60 Hz (±3 Hz), 30 VA MAX.

220 V AC power supply

DC drive: 135 - 190 V DC (±10%), no polarity, 110 mA MAX.

AC drive: 220 - 240 V AC (±10%), 50/60 Hz (±3 Hz), 30 VA MAX.

Reference Operating Conditions

Ambient temperature: 23°C ±2°C, relative humidity: 50% ±10% RH

Note that the power supply voltage is as specified below:

100 V AC and 24 V DC common power supply: 24 V DC or 100 V AC, 50/60 Hz

220 V AC power supply: 135 V DC or 220 V AC, 50/60 Hz

Reference Performance

Item	Specifications
Input and output conversion accuracy rating	
1 to 5 V input signal	±0.1% of span
Direct input	±0.5% or ±(2 × direct input card's accuracy + 0.1%)
Allowable input voltage/current (*1)	
1 to 5 V signal	±30 V DC
Direct input signal (mV, TC)	-0.5 to 4 V DC
Direct input signal (distributor)	+40 mA DC
Warm-up time	1 minute (time taken by the instrument to reach accuracy after power on), but 3 minutes in the case of direct input
Current consumption and power consumption	100 V AC and 24 V DC common power supply 750 mA (20 to 132 V DC) 30 VA (80 to 138 V AC) 220 V AC power supply 110 mA (120 to 340 V DC) 30 VA (138 to 264 V AC)
Insulation resistance	100 MΩ Test voltage = 500 V DC Input or output terminal to grounding terminal, power supply terminal to grounding terminal
Withstand voltage	Between input/output terminal and ground terminal 1000 VAC for one minute (In the case of suffix codes -10□, -12□)
	Between power supply terminal (L, N) and (all I/O terminal and ground terminal) 500 VAC for one minute (In the case of suffix codes -13□, -14□, or -15□)
	Between power supply terminal (L, N) and ground terminal 3000 VAC for one minute (In the case of suffix codes -10□, -12□)
LCD replacement period	8 years

*1: Measurement category according to IEC/EN 61010-1, IEC/EN 61010-2-201, IEC/EN 61010-2-030: O (other)

Regarding the LCD

A small number of missing or steady-on LCD pixels and minor variations in brightness uniformity is a normal display characteristic and not a malfunction.

Influence of Operating Conditions

Item	Specifications
Influence of power supply voltage variations	Accuracy
Influence of input lead resistance	0.13% (per 1 kΩ)
Influence of load resistance	Accuracy /5 2 kΩ to ∞ 1 to 5 V output, 0 to 750 Ω 4 to 20 mA
Common mode noise rejection ratio	83 dB (1 to 5 V input) 50/60 Hz
Series mode noise rejection ratio	46 dB (1 to 5 V input) 50/60 Hz
Influence of magnetic field	Accuracy /5 (400 A/m, 50/60 Hz or DC)
Influence of ambient temperature	Accuracy (per 10°C in the range of 0 to 50°C)
Influence of ambient humidity	Accuracy (50 to 93% RH, 40°C)

6.1 General Specifications

Direct Input Specifications

Item	mV Input	Thermocouple Input
Optional code	/A01	/A02
Input signal	DC potential difference: -50 to +150 mV	JIS, ANSI standards Thermocouple types K, T, J, E, B, R, and S IEC and ANSI standards Type N
Measuring range span	10 to 100 mV DC	10 to 63 mV (thermoelectric power equivalent)
Measuring range zero elevation	Within whichever is smaller, three times the span or ± 50 mV	Within whichever is smaller, three times the span or ± 25 mV
Measuring range	Changeable on Engineering Display	
Input resistor	1 M Ω (3 k Ω at power failure)	
External input resistor	500 Ω or less	
Allowable input voltage and current	-0.5 to 4 V DC	
Input I linearization	Not provided	Provided
1 to 5 V output conversion accuracy rating	Within $\pm 0.2\%$ of span	Whichever is greater, $\pm 0.2\%$ of span or input equivalent ± 20 μ V
Reference junction compensation error	-	Within $\pm 1^\circ\text{C}$ (*1)

*1: Type B does not conduct reference junction temperature compensation.
For types other than type B, the value obtained by multiplying the noted value by the following coefficient (K) applies if the measurement temperature is 0°C or less.

$$K = (\text{thermoelectric power for } 1^\circ\text{C near } 0^\circ\text{C}) / (\text{thermoelectric power for } 1^\circ\text{C at measurement temperature})$$

Item	Resistance Temperature Detector Input	Potentiometer Input
Optional code	/A03	/A04
Input signal	RTD Pt100(IPTS-68: JIS'89), JPt100(JIS'89), Pt100(ITS-90: JIS'97), Pt50(JIS'81), three-wire type Measurement current: 1 mA	Potentiometer three-wire type
Measuring range span	10 to 650°C (Pt 100) 10 to 500°C (JPt 100)	Total resistance: 100 to 2000 Ω Span: 80 to 2000 Ω
Measuring range zero elevation	Within five times the span	50% or less of total resistance
Measuring range	Changeable on Engineering Display	
External input resistance	10 Ω or less per wire (*1)	10 Ω or less per wire
Input linearization	Provided	Not provided
1 to 5 V output conversion accuracy rating	Whichever is greater, $\pm 0.2\%$ of span or $\pm 0.2^\circ\text{C}$	Within $\pm 0.2\%$ of span

*1: The value shall be equal or less than the smaller value out of 10 Ω per wire or (measurement temperature span) \times 0.4 Ω .

Note: There is no difference between the latest and the previous temperature tables as far as applying them to the YS1000.

- TC: Latest version; IEC60584-1: 2013/JIS C1602:2015
Previous version; IEC60584-1: 1995/JIS C1602:1995
- RTD Latest version; IEC60751- 2008/JIS C1604:2013
Previous version; IEC751- 1995/JIS C1604:1997

6.1 General Specifications

Item	Isolator	2-wire Transmitter Input (Isolated), 2-wire Transmitter Input (Non-isolated)
Optional code	/A05	/A06, /A07
Input signal	1 to 5 V DC	4 to 20 mA DC signal from 2-wire transmitter (Power is supplied to a transmitter.)
Input resistance	1 M Ω (100 k Ω at power failure)	250 Ω
External input resistance	-	RL = (20 - transmitter's minimum operating voltage)/0.02 A (Ω) or less
Allowable input voltage and current	\pm 30VDC	40mADC
Input linearization	Not provided	Not provided
1 to 5 V output conversion accuracy rating	Within \pm 0.2% of span	

Item	Frequency Input
Optional code	/A08
Input signal	2-wire type: Contact, voltage pulse, current pulse (power supply to transmitter is also possible) 3-wire type: Power supply type voltage pulse
Input frequency	0 to 10 kHz
100% frequency	0.1 to 10 kHz
Zero elevation	0 to 50% can be set for 100% input frequency.
Measuring range	Changeable on Engineering Display
Low level input cutoff point	Setting range: 0.01 Hz (and 1% of maximum frequency) to 100% input frequency.
Minimum input pulse width	ON: 60 μ s, OFF: 60 μ s (input frequency: 0 to 6 kHz) ON: 30 μ s, OFF: 30 μ s (input frequency: 6 to 10 kHz)
Input signal level	Contact input: relay contact, transistor contact Open/close detection level: Open: 100 k Ω or more, Close: 200 Ω or less Contact capacity: 15 V DC, 15 mA or more Voltage/current pulse input: Low level: -1 to +8 V, High level: +3 to +24 V Pulse peak value: 3 V or more (input frequency: 0 to 6 kHz) 5 V or more (input frequency: 6 to 10 kHz)
Internal load resistance (for current pulse input)	Selectable from 200 Ω , 500 Ω , and 1 k Ω ; to be specified when ordering
Input filter	Selectable whether to add a 10 ms filter (for no-voltage contact); to be specified when ordering
Power supply for transmitter	Selectable from 12 V DC at 30 mA, and 24 V DC at 30 mA; to be specified when ordering
1 to 5 V output conversion accuracy rating	Within \pm 0.2% of span

6.1 General Specifications

Structure, Mounting (Main Unit of Standard Type)

Item		Specifications
Structure		Front panel drip and dust proof structure (compliant with IP54). Not applicable for side-by-side mounting instrumentation, and replacement types.
Mounting type		Indoor panel mounting
Panel mounting device		Mounting brackets to be used (at the top and bottom))
Panel cutout		137 ⁺² × 68 ^{+0.7} (mm)
Connection method	External signal connection	M4-screw terminal connection
	Power supply and grounding connection	M4-screw terminal connection
External Dimensions		144 × 72 × 250 mm (height × width × depth from the panel)
Weight		1.6kg

Safety Standards

- **General safety standards (suffix codes -10□, or -12□ only)**

IEC/EN 61010-1, IEC/EN 61010-2-201, IEC/EN 61010-2-030 compliant

Overvoltage category: II, Pollution degree: 2

Measurement category: O (other)

When option code /A08 is specified, the conformity to CE marking is excluded.

Compliant with CAN/CSA-C22.2 for suffix codes -10□ or -12□ and option code /CSA

CSA: CAN/CSA-C22.2 NO. 61010-1 and CAN/CSA-C22.2, NO. 61010-2-030

Overvoltage category: II Pollution

Degree: 2

Measurement category: O (other)



Notes regarding safety standards

1) The internal unit alone is not covered by the safety standards.

The products comply with the safety standards when configured in combination with the internal unit and the safety standard-compliant case or safety standard-compliant housing.

2) The following work involving removing the internal unit from the case and reinstalling it in the case requires safety verification, as specified by the safety standards (IEC/EN 61010-1).

Such work must be carried out by a YOKOGAWA engineer or by YOKOGAWA-approved personnel and must be subjected to inspection (such as withstand tests) to verify safety. If the work is carried out at the customer's own risk, the instrument concerned cannot be regarded as being compatible with the safety standards.

[1] Removal of the internal unit from the case, replacing the internal unit with a new one, and subsequently installing it to the case/housing

[2] Replacement and installation of the power supply unit, or optional board

[3] Maintenance or repair requiring removal of the internal unit from the case

- **EMC standards (suffix codes -10□, or -12□ only)**

Use a ferrite core and an arrester to comply with the standards.

EN61326-1 Class A, Table 2 (For use in industrial locations)

EN61326-2-3

EN55011 Class A Group 1

EN61000-3-2 Class A

EN61000-3-3

Note: The instrument continues operating at a measuring accuracy of within $\pm 20\%$ of the range during testing.

KC marking: Electromagnetic wave interference prevention standard, electromagnetic wave protection standard compliance.

The suffix codes -x0x, -x1x, -x2x -x3x, and -x4x for YS1000 series and YSS1000 comply with KC marking.

EMC Regulatory Arrangement in Australia and New Zealand

EN 55011 Class A, Group 1



CAUTION

This instrument is a class A product (use in commercial and industrial areas). In a domestic environment this product may cause radio interference in which case the user needs to take adequate measures.

When option code /A08 is specified, the conformity to CE marking is excluded.

6.1 General Specifications

- **Hazardous location usage certification: Non-incendive electric equipment that is used in hazardous locations (optional code /FM, /CSA only)**

FM nonincendive: Class 3600:2011
 Class 3611:2004
 Class 3810:2005
 Locations: Class I, Division 2, Groups A,B,C and D
 Class I, Zone 2, Groups II C
 Temperature Code: T4
 CSA nonincendive: C22. 2 No. 213-M1987
 CAN/CSA-C22.2 No. 0-10
 CAN/CSA-C22.2 No. 0.4-04
 Locations: Class I, Division 2, Groups A,B,C and D
 Temperature Code: T4

Hazardous location usage conditions: (Note 2), (Note 6)

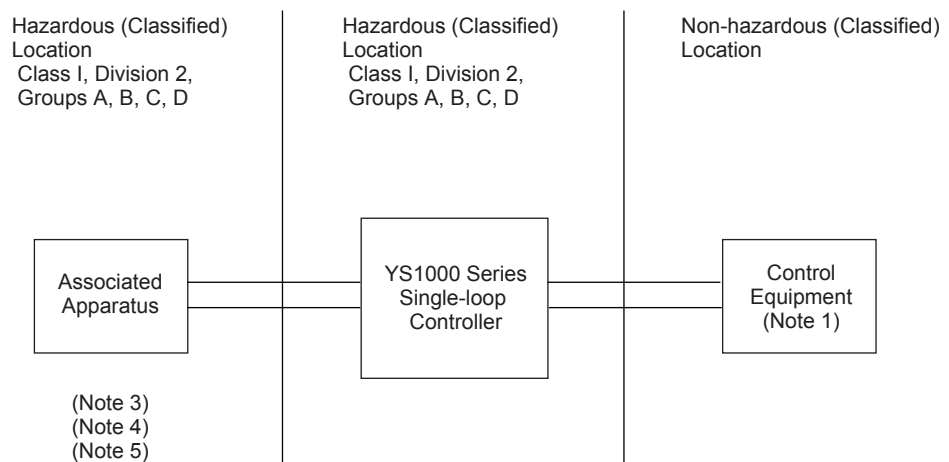

0601E.ai

Non-incendive Field Wiring Parameter:

Output signal	Signal name	Voc (V)	Isc (mA)	Ca (uF)	La (mH)	Remark
Loop power supply for transmitter (LPS)	Power supply	25.5	90	0.2	1	*1
Digital Input (DI1)	Non-voltage contact	7.25	20	0.9	50	
RS-485		4.4	250	0.9	1	

The Non-incendive field wiring concept allows interconnection of two FM Approved Non-incendive Apparatuses with Non-incendive field wiring parameters not specifically examined in combination as a system when:

$$Voc \leq V_{max}, I_{sc} \leq I_{max}, C_a \geq C_i + C_{\text{cable}}, L_a \geq L_i + L_{\text{cable}}$$

*1: Upon condition that a shunt resistor YS021 (250 Ω \pm 0.1%, 3W) is attached.

Input signal	Signal name	Vmax (V)	Imax (mA)	Ci (uF)	Li (mH)	Remark
Analog Input (X1 to X2)	Voltage input	30	0.034	0.001	0	
Digital Output (DO1 to DO6)	Transistor output	30	200	0	0	*2

The Non-incendive field wiring concept allows interconnection of two FM Approved Non-incendive Apparatuses with Non-incendive field wiring parameters not specifically examined in combination as a system when:

$$V_{oc} \text{ or } V_t \leq V_{max}, I_{sc} \text{ or } I_t \leq I_{max}, C_a \geq C_i + C_{\text{cable}}, L_a \geq L_i + L_{\text{cable}}$$

*2: Class I, Division 2 Wiring required.

Notes:

1. Control equipment connected to the YS1000 series single-loop controller must not use or generate more than 250 Vrms or VDC.
2. In case of option code /FM, install devices according to NEC (National Electrical Code: ANSI/NFPA-70). In case of option code /CSA, all wiring shall comply with Canadian Electrical Code Part I and local electrical codes.
3. For the YS1000 with FM option, be sure to use the associated apparatus that must be FM Approval under Non-incendive Field Wiring Concept, or to use a simple apparatus (a device which can neither generate nor store more than 1.2 V, 0.1 A, 25 mW, or 20 μ J, e.g. Switches, thermocouples, LED's and RTD's).
4. Associated Apparatus manufacture's installation drawing must be followed when installing this equipment.
5. Associated Apparatus connection is representative of each input and output signal connection. Each signal shall be wired in a separate shielded cable.
6. No revision to drawing without prior FM and CSA Approval.

Parameter of the Device which Gives Energy

- Voc: maximum open-circuit output voltage
Maximum voltage that occurs at the open terminal (part) when the Non-incendive (NI) circuit is open
- Isc: maximum short-circuit output current
Maximum current which currents when the NI circuit is short and earth fault
- Ca: maximum allowable capacitance
Maximum capacitance that can be connected to the NI circuit
- La: maximum allowable inductance
Maximum inductance that can be connected to the NI circuit

Parameter of the Device which Receives Energy

- Vmax: maximum input voltage
Maximum voltage that maintains the NI properties of the device
- Imax: maximum input current
Maximum current that maintains the properties of the device
- Ci: maximum internal capacitance
Maximum internal capacitance of the device that can be considered to conduct to the NI circuit (the external wiring) when the device is connected to the NI circuit (the external wiring)
- Li: maximum internal inductance
Maximum internal inductance of the device that can be considered to conduct to the NI circuit (the external wiring) when the device is connected to the NI circuit (the external wiring)

Index

A

Active Display	1-9
Alarm Detecting Function	1-4
Alarm Function	1-3
Alarm output function.....	1-3
Alternate Tag Number Color Display	1-10

B

Background color.....	2-11
Brightness.....	2-12
Burnout.....	3-5

C

Calibration Instruments.....	5-1
------------------------------	-----

D

Deletion Guide Display Language	1-8
Digital input.....	2-10
Digital Input.....	1-6
Direct Input	3-1
Display Data on the TREND 3 Display	2-6
Display Function	2-1
During Power Failures	4-1

E

EMC standards.....	6-8
Event Display.....	1-7
Event flag.....	1-8

F

First-order Lag Operation	1-2
Function Block Diagram	1-1

H

Hazardous location usage certification.....	6-9
Hysteresis.....	1-5

I

Indication Accuracy.....	5-1
Input Filter.....	1-2

L

LCD backlight is OFF	2-10
LCD Backlight OFF Input.....	1-6
Loop Colors	2-11
Low Cutoff Adjustable.....	1-2

M

Messages	1-7
----------------	-----

O

OFF timer	2-10
Operation Display.....	2-1,2-9

P

Part Replacement.....	5-2
Parts with finite life spans.....	5-2
Password.....	2-13
Power-on initial display.....	2-9

R

Repair.....	5-3
-------------	-----

S

Safety Standard.....	6-8
Scale Divisions	2-7,2-8
Scale Values.....	2-8
Security Function.....	2-13
Sensor Type	3-4
Simulation Display	1-8
Span Adjustment	3-6
Specifications	6-1
Square Root Extraction	1-2

T

Time Span	2-5
TREND Display	2-4,2-5

Z

Zero Adjustment	3-6
-----------------------	-----

Revision Information

- Title : YS1310 Indicator with Alarm User's Manual
- Manual No. : IM 01B08D02-02EN

June 2014/1st Edition

Newly published

May 2015/2nd Edition

FM, CSA nonincendive (optional) approvals. (excluding the compatible type for YS100)

Mar. 2016/3rd Edition

Safety standard IEC/EN 61010-2-201 conformity.

Dec. 2019/4th Edition

Page 6-3, Description of maximum number of transactions

Page 6-9, Description of the notice of alteration contents (standards related)

■ Written by Yokogawa Electric Corporation
■ Published by Yokogawa Electric Corporation
2-9-32 Nakacho, Musashino-shi, Tokyo 180-8750, JAPAN



YOKOGAWA ELECTRIC CORPORATION**Headquarters**

9-32, Nakacho, 2-chome, Musashino-shi, Tokyo, 180-8750 JAPAN
Phone : 81-422-52-5555

Branch Sales Offices

Osaka, Nagoya, Kurashiki, Hiroshima, Fukuoka, Kitakyusyu

YOKOGAWA CORPORATION OF AMERICA**Head Office**

12530 West Airport Blvd, Sugar Land, Texas 77478, USA
Phone : 1-281-340-3800 Fax : 1-281-340-3838

Georgia Office

2 Dart Road, Newnan, Georgia 30265, USA
Phone : 1-800-888-6400 Fax : 1-770-254-0928

YOKOGAWA AMERICA DO SUL LTDA.

Praca Acapulco, 31 - Santo Amaro, São Paulo/SP, BRAZIL, CEP-04675-190
Phone : 55-11-5681-2400 Fax : 55-11-5681-4434

YOKOGAWA EUROPE B. V.

Euroweg 2, 3825 HD Amersfoort, THE NETHERLANDS
Phone : 31-88-4641000 Fax : 31-88-4641111

YOKOGAWA ELECTRIC CIS LTD.

Grokholsky per 13 Building 2, 4th Floor 129090, Moscow, RUSSIA
Phone : 7-495-737-7868 Fax : 7-495-737-7869

YOKOGAWA CHINA CO., LTD.

3F Tower D Cartelo Crocodile Building, No.568 West Tianshan Road,
Shanghai 200335, CHINA
Phone : 86-21-62396262 Fax : 86-21-62387866

YOKOGAWA ELECTRIC KOREA CO., LTD.

(Yokogawa B/D, Yangpyeong-dong 4-Ga), 21, Seonyu-ro 45-gil, Yeongdeungpo-gu,
Seoul, 07209, KOREA
Phone : 82-2-2628-6000 Fax : 82-2-2628-6400

YOKOGAWA ENGINEERING ASIA PTE. LTD.

5 Bedok South Road, Singapore 469270, SINGAPORE
Phone : 65-6241-9933 Fax : 65-6241-2606

YOKOGAWA INDIA LTD.

Plot No.96, Electronic City Complex, Hosur Road, Bangalore - 560 100, INDIA
Phone : 91-80-4158-6000 Fax : 91-80-2852-0625

YOKOGAWA AUSTRALIA PTY. LTD.

Tower A, 112-118 Talavera Road, Macquarie Park NSW 2113, AUSTRALIA
Phone : 61-2-8870-1100 Fax : 61-2-8870-1111

YOKOGAWA MIDDLE EAST & AFRICA B.S.C.(C)

P.O. Box 10070, Manama, Building 577, Road 2516, Busaiteen 225, Muharraq,
BAHRAIN
Phone : 973-17-358100 Fax : 973-17-336100