

HIMax[®]

Analog Output Module Manual

SAFETY
NONSTOP



X-AO 16 51

All HIMA products mentioned in this manual are protected by the HIMA trade-mark. Unless noted otherwise, this also applies to other manufacturers and their respective products referred to herein.

All of the instructions and technical specifications in this manual have been written with great care and effective quality assurance measures have been implemented to ensure their validity. For questions, please contact HIMA directly. HIMA appreciates any suggestion on which information should be included in the manual.

Equipment subject to change without notice. HIMA also reserves the right to modify the written material without prior notice.

For further information, refer to the CD-ROM and our website <http://www.hima.de> and <http://www.hima.com>.

© Copyright 2011, HIMA Paul Hildebrandt GmbH + Co KG

All rights reserved

Contact

HIMA Address

HIMA Paul Hildebrandt GmbH + Co KG

P.O. Box 1261

68777 Brühl, Germany

Phone: +49 6202 709-0

Fax: +49 6202 709-107

E-mail: info@hima.com

Revision index	Revisions	Type of Change	
		technical	editorial
4.00	First Edition of the Manual		

Table of Contents

1	Introduction	5
1.1	Structure and Use of this Manual	5
1.2	Target Audience	5
1.3	Formatting Conventions	6
1.3.1	Safety Notes	6
1.3.2	Operating Tips	7
2	Safety	8
2.1	Intended Use	8
2.1.1	Environmental Requirements	8
2.1.2	ESD Protective Measures	8
2.2	Residual Risk	9
2.3	Safety Precautions	9
2.4	Emergency Information	9
3	Product Description	10
3.1	Safety Function	10
3.1.1	Reaction in the Event of a Fault	10
3.2	Scope of Delivery	10
3.3	Type Label	11
3.4	Structure	12
3.4.1	Block Diagram	12
3.4.2	Indicators	13
3.4.3	Module Status Indicators	14
3.4.4	System Bus Indicators	15
3.4.5	I/O Indicators	15
3.5	Product Data	16
3.6	Connector Boards	18
3.6.1	Mechanical Coding of Connector Boards	18
3.6.2	Coding of X-CB 014 5X Connector Boards	19
3.6.3	Pin Assignment for Connector Boards with Screw Terminals	20
3.6.4	Terminal Assignment for Mono Connector Boards with Screw Terminals	21
3.6.5	Pin Assignment for Connector Boards with Cable Plug	22
3.6.6	Pin Assignment for Mono Connector Boards with Cable Plug	23
3.7	System Cable X-CA 011	24
3.7.1	Cable Plug Coding	25

4	Start-up	26
4.1	Mounting	26
4.1.1	Wiring Outputs not in Use	26
4.2	Mounting and Removing the Module.....	27
4.2.1	Mounting a Connector Board	27
4.2.2	Mounting and Removing the Module.....	29
4.3	Configuring the Module in SILworX.....	31
4.3.1	Tab: Module	32
4.3.2	Tab: I/O Submodule AO16_01	33
4.3.3	Tab: I/O Submodule AO16_01: Channels.....	34
4.3.4	Submodule Status [DWORD]	35
4.3.5	Diagnostic Status [DWORD].....	35
4.4	Connection Variants.....	36
4.4.1	Single-Channel Output Wiring	36
4.4.2	Closed-Loop Control	37
4.4.3	Connection via Field Termination Assembly	38
4.4.4	Characteristics of HART Communication	38
5	Operation	39
5.1	Handling	39
5.2	Diagnosis	39
6	Maintenance	40
6.1	Maintenance Measures	40
6.1.1	Loading the Operating System	40
6.1.2	Proof Test.....	40
7	Decommissioning.....	41
8	Transport	42
9	Disposal	43
	Appendix	45
	Glossary	45
	Index of Figures.....	46
	Index of Tables	47
	Index	48

1 Introduction

The present manual describes the technical characteristics of the module and its use. It provides information on how to install, start up and configure the module in SILworX.

1.1 Structure and Use of this Manual

The content of this manual is part of the hardware description of the HIMax programmable electronic system.

This manual is organized in the following main chapters:

- Introduction
- Safety
- Product Description
- Start-up
- Operation
- Maintenance
- Decommissioning
- Transport
- Disposal

Additionally, the following documents must be taken into account:

Name	Content	Document no.
HIMax System manual	Hardware description of the HIMax system	HI 801 001 E
HIMax Safety manual	Safety functions of the HIMax system	HI 801 003 E
HIMax Communication manual	Description of communication and protocols	HI 801 101 E
SILworX Online Help (OLH)	Instructions on how to use SILworX	-
First Steps	Introduction to SILworX	HI 801 103 E

Table 1: Additional Relevant Manuals

The latest manuals can be downloaded from the HIMA website at www.hima.com. The revision index on the footer can be used to compare the current version of existing manuals with the Internet edition.

1.2 Target Audience

This document addresses system planners, configuration engineers, programmers of automation devices and personnel authorized to implement, operate and maintain the devices and systems. Specialized knowledge of safety-related automation systems is required.

1.3 Formatting Conventions

To ensure improved readability and comprehensibility, the following fonts are used in this document:

Bold:	To highlight important parts Names of buttons, menu functions and tabs that can be clicked and used in SILworX.
<i>Italics:</i>	System parameter and variables
Courier	Literal user inputs
RUN	Operating state are designated by capitals
Chapter 1.2.3	Cross references are hyperlinks even though they are not particularly marked. When the cursor hovers over a hyperlink, it changes its shape. Click the hyperlink to jump to the corresponding position.

Safety notes and operating tips are particularly marked.

1.3.1 Safety Notes

The safety notes are represented as described below.

These notes must absolutely be observed to reduce the risk to a minimum. The content is structured as follows:

- Signal word: danger, warning, caution, notice
- Type and source of danger
- Consequences arising from the danger
- Danger prevention

SIGNAL WORD



Type and source of danger!
Consequences arising from the danger
Danger prevention

The signal words have the following meanings:

- Danger indicates hazardous situation which, if not avoided, will result in death or serious injury.
- Warning indicates hazardous situation which, if not avoided, could result in death or serious injury.
- Caution indicates hazardous situation which, if not avoided, could result in minor or modest injury.
- Notice indicates a hazardous situation which, if not avoided, could result in property damage.

NOTICE



Type and source of damage!
Damage prevention

1.3.2 Operating Tips

Additional information is structured as presented in the following example:

i

The text corresponding to the additional information is located here.

Useful tips and tricks appear as follows:

TIP

The tip text is located here.

2 Safety

All safety information, notes and instructions specified in this manual must be strictly observed. The product may only be used if all guidelines and safety instructions are adhered to.

This product is operated in accordance with SELV or PELV. No imminent danger results from the module itself. The use in Ex-Zone is permitted if additional measures are taken.

2.1 Intended Use

HIMax components are designed for assembling safety-related controller systems.

When using the components in the HIMax system, comply with the following general requirements

2.1.1 Environmental Requirements

Requirement type	Range of values
Protection class	Protection class III in accordance with IEC/EN 61131-2
Ambient temperature	0...+60 °C
Storage temperature	-40...+85 °C
Pollution	Pollution degree II in accordance with IEC/EN 61131-2
Altitude	< 2000 m
Housing	Standard: IP20
Supply voltage	24 VDC

Table 2: Environmental Requirements

Exposing the HIMax system to environmental conditions other than those specified in this manual can cause the HIMax system to malfunction.

2.1.2 ESD Protective Measures

Only personnel with knowledge of ESD protective measures may modify or extend the system or replace modules.

NOTE



Device damage due to electrostatic discharge!

- When performing the work, make sure that the working area is free of static and wear an ESD wrist strap.
- If not used, ensure that the device is protected from electrostatic discharge, e.g., by storing it in its packaging.

2.2 Residual Risk

No imminent danger results from a HIMax module itself.

Residual risk may result from:

- Faults in the engineering
- Faults in the user program
- Faults in the wiring

2.3 Safety Precautions

Observe all local safety requirements and use the protective equipment required on site.

2.4 Emergency Information

A HIMax controller is a part of the safety equipment of a system. If the controller fails, the system adopts the safe state.

In case of emergency, no action that may prevent the HIMax systems from operating safely is permitted.

3 Product Description

The X-AO 16 51 standard module is an analog output module and it is intended for use in the programmable electronic system (PES) HIMax.

The analog input module is inserted in any of the base plate slots with the exception of the slots reserved for system bus modules. For more information, refer to the System Manual (HI 801 001 E).

The module is equipped with 16 analog outputs with a nominal range from 4 mA to 20 mA.

The analog outputs are suitable for connecting ohmic, inductive and capacitive loads and lamps in accordance with EN 61131-2.

The outputs of the X-AO 16 51 output module are non-galvanically isolated and cannot therefore be redundantly connected. Use the safe X-AO 16 01 output module to connect analog outputs redundantly.

The standard module can be operated with safety-related modules within one base plate.

The standard module is non-reactive to the safety-related modules. In particular, this includes EMC, electrical safety, communication to the X-SB and X-CPU modules and the user program.

Module and connector boards are mechanically coded, see Chapter 3.6.1. This measure ensures that a safety-related module cannot be replaced by a standard module.

Refer to the HIMax Safety Manual (HI 801 003 E) for more information on the standards used to test and certify the modules and the HIMax system.

3.1 Safety Function

The module does not perform any safety-related functions.

The parameters and status for this module must not be used for safety functions.

3.1.1 Reaction in the Event of a Fault

The module activates the *Error* LED on the front plate.

3.2 Scope of Delivery

The module must be installed on a suitable connector board to be able to operate. If a FTA is used, a system cable is required to connect the connector board to the FTA. Connector boards, system cables and FTAs are not included within the scope of delivery.

The connector boards are described in Chapter 3.6, the system cables are described in Chapter 3.7. The FTAs are described in own manuals.

3.3 Type Label

The type label specifies the following important details:

- Product name
- Mark of conformity
- Bar code (2D or 1D code)
- Part number (Part-No.)
- Hardware revision index (HW Rev.)
- Software revision index (SW Rev.)
- Operating voltage (Power)
- Ex specifications (if applicable)
- Production year (Prod-Year:)

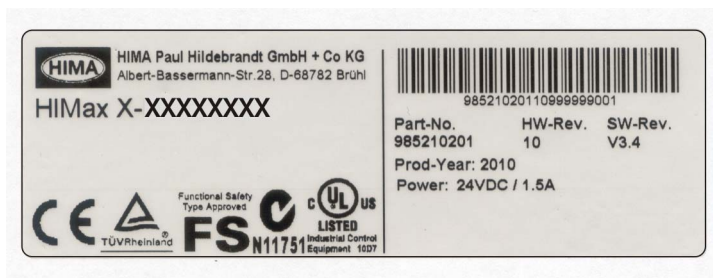

Figure 1: Sample Type Label

3.4 Structure

The module is equipped with 16 analog current outputs (0/4...20 mA) that are not galvanically isolated from the supply voltage and the remaining channel pairs. The analog current value is configured through a D/A converted.

The processor system for the I/O module controls and monitors the I/O level. The data and states of the I/O module are made available to the processor modules via the redundant system bus. The system bus has a redundant structure for reasons of availability. Redundancy is only ensured if both system bus modules are inserted in the base plates and configured in SILworX.

3.4.1 Block Diagram

The following block diagram illustrates the structure of the module.

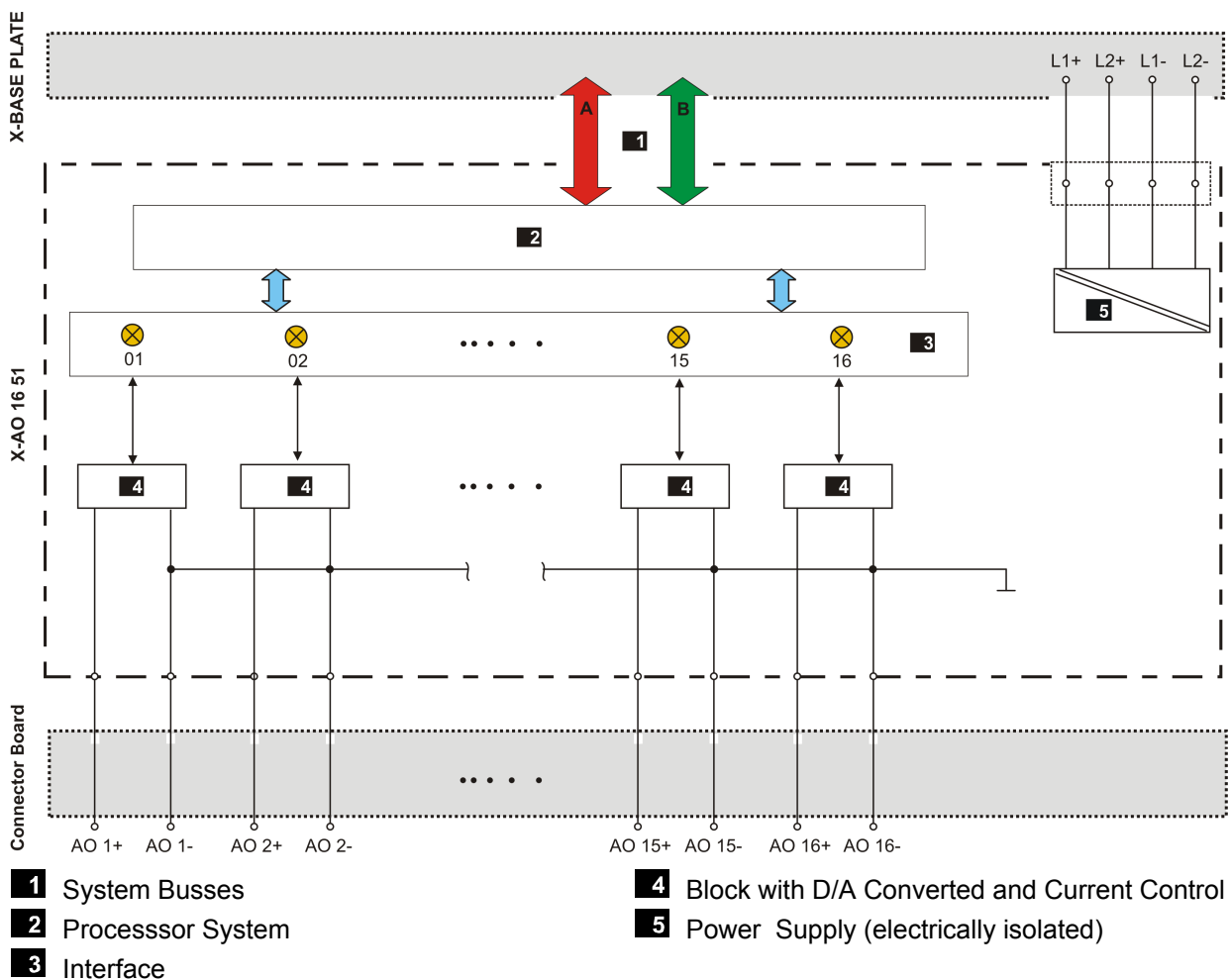

Figure 2: Block Diagram

3.4.2 Indicators

The following figure shows the LED indicators for the module.

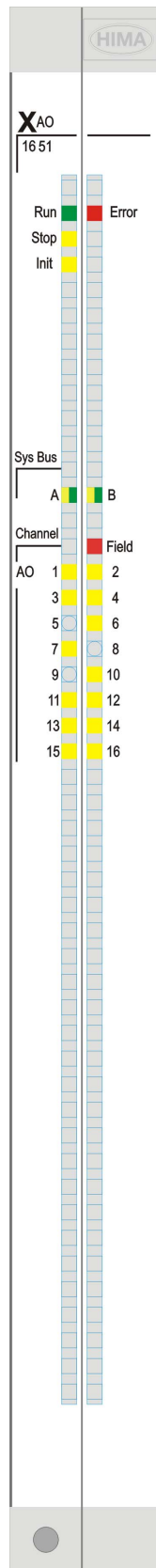

Figure 3: Indicators

The LEDs indicate the operating state of the module.

The LEDs on the module are divided into three groups:

- Module status indicators (Run, Error, Stop, Init)
- System bus indicators (A, B)
- I/O indicators (AO 1...16, Field)

When the supply voltage is switched on, a LED test is performed and all LEDs briefly flash simultaneously.

Definition of Blinking Frequencies

The following table defines the blinking frequencies of the LEDs:

Name	Blinking Frequencies
Blinking1	Long (approx. 600 ms) on, long (approx. 600 ms) off
Blinking2	Short (approx. 200 ms) on, short (approx. 200 ms) off, short (approx. 200 ms) on, long (approx. 600 ms) off
Blinking-x	Ethernet communication: Flashing in sync with data transfer

Table 3: Blinking Frequencies of LEDs

3.4.3 Module Status Indicators

These LEDs are located on the front plate, on the upper part of the module.

LED	Color	Status	Description
Run	Green	On	Module in RUN, normal operation
		Blinking1	Module state: STOP/OS_DOWNLOAD or OPERATE (only with processor modules)
		Off	Module not in RUN, observe the other status LEDs
Error	Red	On/Blinking1	Internal module faults detected by self-tests, e.g., hardware, software or voltage supply. Fault while loading the operating system
		Off	Normal operation
Stop	Yellow	On	Module state: STOP / VALID CONFIGURATION
		Blinking1	Module state: STOP / INVALID CONFIGURATION or STOP / OS_DOWNLOAD
		Off	Module not in STOP, observe the other status LEDs
Init	Yellow	On	Module state: INIT, observe the other status LEDs
		Blinking1	Module state: LOCKED, observe to the other status LEDs
		Off	Module state: neither INIT nor LOCKED, observe the other status LEDs

Table 4: Module Status Indicators

3.4.4 System Bus Indicators

The system bus LEDs are labeled *Sys Bus*.

LED	Color	Status	Description
A	Green	On	Physical and logical connection to the system bus module in slot 1.
		Blinking1	No physical connection to the system bus module in slot 1.
	Yellow	Blinking1	The physical connection to the system bus module in slot 1 has been established. No connection to a (redundant) processor module running in system operation.
B	Green	On	Physical and logical connection to the system bus module in slot 2.
		Blinking1	No physical connection to the system bus module in slot 2.
	Yellow	Blinking1	The physical connection to the system bus module in slot 2 has been established. No connection to a (redundant) processor module running in system operation.
A+B	Off	Off	Neither physical nor logical connection to the system bus modules in slot 1 and slot 2.

Table 5: System Bus Indicators

3.4.5 I/O Indicators

The LEDs of the I/O indicators are labeled *Channel*.

LED	Color	Status	Description
Channel 1...16	Yellow	On	The related channel is active (energized), current ≥ 4 mA.
		Blinking2	Channel fault, current not equal to set value
		Off	The related channel is inactive (de-energized), current < 4 mA.
Field	Red	Blinking2	Field fault on at least one channel or supply (e.g., overcurrent, etc.)
		Off	No field fault displayed!

Table 6: I/O LEDs

3.5 Product Data

General	
Supply voltage	24 VDC, -15 %...+20 %, $r_p \leq 5\%$, SELV, PELV
Current input	max. 1.3 A
Current input, all outputs are switched off.	min. 0.6 A
Current input per channel	80 mA
Operating temperature	0...+60 °C
Storage temperature	-40...+85 °C
Humidity	max. 95 % relative humidity, non-condensing
Type of protection	IP20
Dimensions (H x W x D) in mm	310 x 29.2 x 230
Weight	approx. 1.2 kg

Table 7: Product Data

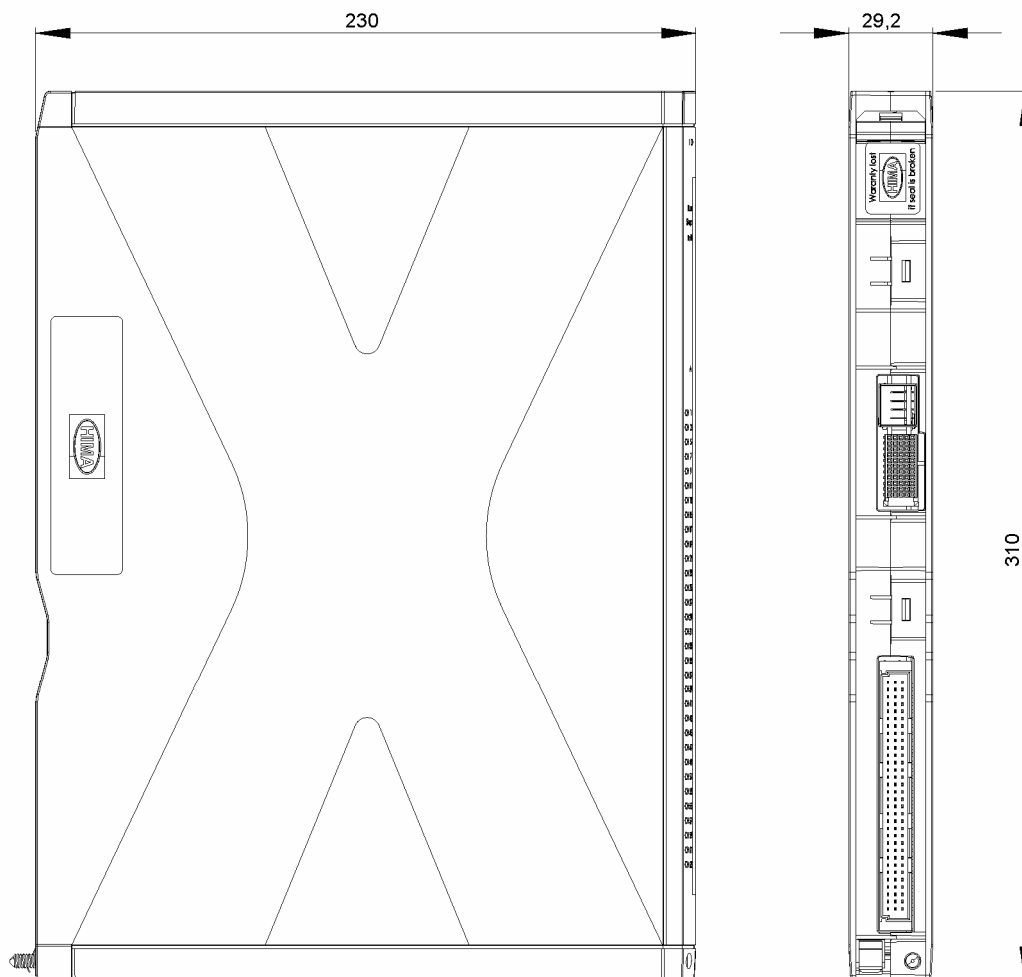

Figure 4: Views

Analog outputs	
Number of analog outputs	16 The analog outputs are not electrically isolated from one another and from the voltage supply.
Nominal range	4...20 mA
Operating range	0...22.5 mA
Digital resolution	16-bit (10 000 digits in SILworX)
Value of LSB	≤ 2 µA
Ohmic load	max. 600 Ω
Inductive load	max. 1 mH
Capacitive load	max. 100 µF in parallel to the ohmic load
Settling time	5 ms
Shutdown time if a fault occurs (transition to the safe state)	16 ms
Metrological accuracy	
Metrological accuracy at 25 °C, max.	≤ ± 0.2 % of final value
Metrological accuracy on full temperature, max.	≤ ± 0.5 % of final value
Temperature coefficient, max.	≤ ± 0.05 %/ K of final value
Metrological accuracy with HART communication, max.	≤ ± 2 % of final value
Linearity error, max.	≤ ± 0.1 %
Safety-related accuracy	≤ ± 2 % of final value

Table 8: Specifications for the Analog Outputs

3.6 Connector Boards

A connector board connects the module to the field zone. Module and connector board form together a functional unit. Insert the connector board into the appropriate slot prior to mounting the module on the base plate.

The following connector boards are available for the module:

Connector board	Description
X-CB 014 51	Connector board with screw terminals
X-CB 014 53	Connector board with cable plug

Table 9: Available Connector Boards

3.6.1 Mechanical Coding of Connector Boards

I/O modules and connector boards are mechanically coded starting from hardware revision AS00 to prevent them from being equipped with improper I/O modules. Coding avoids incorrect installation of improper I/O modules thus preventing negative effects on field zone. A part from that, improper equipment has no effect on the HIMax system since only I/O modules that are correctly configured in SILworX enter the RUN state.

I/O modules and the corresponding connector boards have a mechanical coding in form of wedges. The coding wedges in the female connector of the connector board match with the male connector recesses of the I/O module plug, see Figure 5.

Coded I/O modules can only be plugged in to the corresponding connector boards.

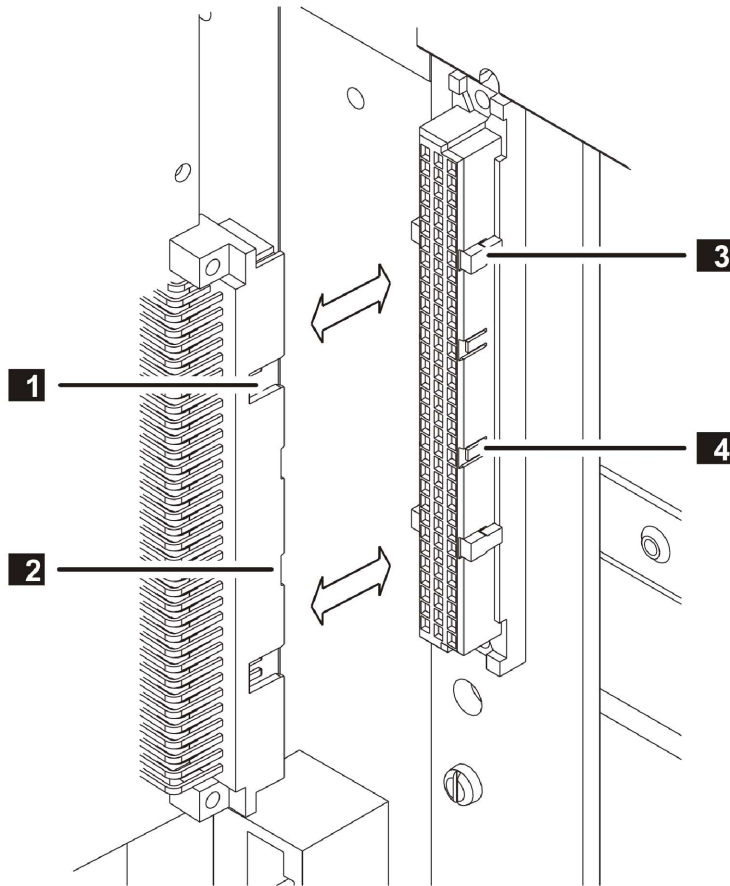

- 1** Male Connector Recess
- 2** Prepared Male Connector Recess
- 3** Coding Wedge
- 4** Guideway for Coding Wedge

Figure 5: Coding Example

Coded I/O modules can be plugged in to uncoded connector boards. Uncoded I/O modules cannot be plugged in to coded connector boards.

3.6.2 Coding of X-CB 014 5X Connector Boards

a7	a13	a20	a26	c7	c13	c20	c26
X	X		X			X	

Table 10: Position of Coding Wedges

3.6.3 Pin Assignment for Connector Boards with Screw Terminals

Mono

X-CB 014 51

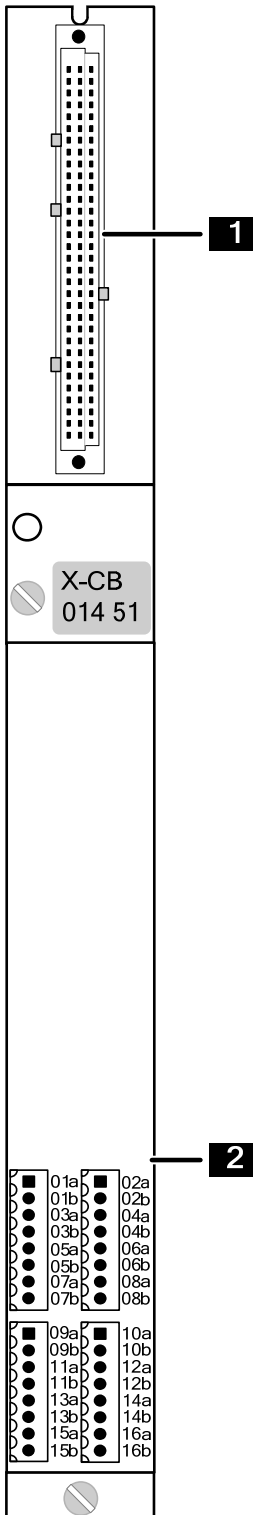

1 I/O Module Plug

2 Connection to the Field Zone (Screw Terminal Connector Block)

Figure 6: Connector Boards with Screw Terminals

3.6.4 Terminal Assignment for Mono Connector Boards with Screw Terminals

Pin no.	Designation	Signal	Pin no.	Designation	Signal
1	01a	AO1+	1	02a	AO2+
2	01b	AO1-	2	02b	AO2-
3	03a	AO3+	3	04a	AO4+
4	03b	AO3-	4	04b	AO4-
5	05a	AO5+	5	06a	AO6+
6	05b	AO5-	6	06b	AO6-
7	07a	AO7+	7	08a	AO8+
8	07b	AO7-	8	08b	AO8-
Pin no.	Designation	Signal	Pin no.	Designation	Signal
1	09a	AO9+	1	10a	AO10+
2	09b	AO9-	2	10b	AO10-
3	11a	AO11+	3	12a	AO12+
4	11b	AO11-	4	12b	AO12-
5	13a	AO13+	5	14a	AO14+
6	13b	AO13-	6	14b	AO14-
7	15a	AO15+	7	16a	AO16+
8	15b	AO15-	8	16b	AO16-

Table 11: Terminal Assignment for Mono Connector Boards with Screw Terminals

Cable plugs attached to the connector board pin headers are used to connect to the field zone.

The cable plugs feature the following properties:

Connection to the field zone	
Cable plugs	4 pieces, with 8 poles
Wire cross-section	0.2...1.5 mm ² (single-wire) 0.2...1.5 mm ² (finely stranded) 0.2...1.5 mm ² (with wire end ferrule)
Stripping length	6 mm
Screwdriver	Slotted 0.4 x 2.5 mm
Tightening torque	0.2...0.25 Nm

Table 12: Cable Plug Properties

3.6.5 Pin Assignment for Connector Boards with Cable Plug

Mono

X-CB 014 53

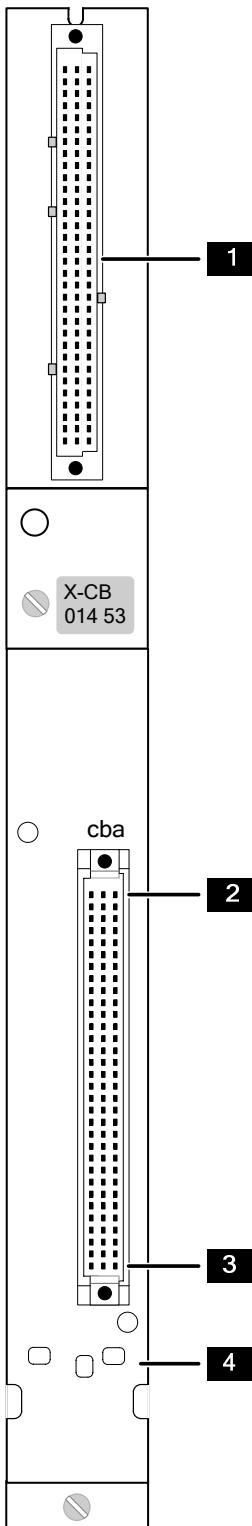

1 I/O Module Plug

2 Connection to the Field Zone (Cable Plug in Row 1)

3 Connection to the Field Zone (Cable Plug in Row 32)

4 Coding for Cable Plugs

Figure 7: Connector Boards with Cable Plug

3.6.6 Pin Assignment for Mono Connector Boards with Cable Plug

HIMA provides ready-made system cables for use with this connector board, see Chapter 3.7.

The cable plug and the connector boards are coded.

i

Connector pin assignment!

The following table describes the connector pin assignment of the system cable plug.

Lead marking based on DIN 47100:

Row	C		b		a	
	Signal	Color	Signal	Color	Signal	Color
1	n.c.		n.c.		U1-D1A	YE-BK
2	n.c.		n.c.		U1-D1B	GN-BK
3	n.c.		n.c.		U1-D2A	YE-RD
4	n.c.		n.c.		U1-D2B	GN-RD
5	n.c.		n.c.			
6	n.c.		n.c.			
7	n.c.		n.c.			
8	n.c.		n.c.			
9	n.c.		n.c.			
10	n.c.		n.c.			
11	n.c.		n.c.			
12	n.c.		n.c.			
13	n.c.		n.c.			
14	n.c.		n.c.			
15	n.c.		n.c.			
16	n.c.		n.c.			
17	AO16+	YE-BU	AO16-	GN-BU		
18	AO15+	YE-PK	AO15-	PK-GN		
19	AO14+	YE-GY	AO14-	GY-GN		
20	AO13+	BN-BK	AO13-	WH-BK		
21	AO12+	BN-RD	AO12-	WH-RD		
22	AO11+	BN-BU	AO11-	WH-BU		
23	AO10+	PK-BN	AO10-	WH-PK		
24	AO9+	GY-BN	AO9-	WH-GY		
25	AO8+	YE-BN	AO8-	WH-YE		
26	AO7+	BN-GN	AO7-	WH-GN		
27	AO6+	RD-BU	AO6-	GY-PK		
28	AO5+	VT	AO5-	BK		
29	AO4+	RD	AO4-	BU		
30	AO3+	PK	AO3-	GY		
31	AO2+	YE	AO2-	GN		
32	AO1+	BN	AO1-	WH		

Table 13: Pin Assignment for Mono Connector Boards with Cable Plug

3.7 System Cable X-CA 011

The X-CA 011 system cable is used to wire the X-CB 014 53 connector board with the field zone via field termination assemblies.

General	
Cable	LIYCY-TP 18 x 2 x 0.25 mm ²
Wire	Finely stranded
Average outer diameter (d)	approx. 12.7 mm
Minimum bending radius	
Fixed laying	5 x d
Flexible application	10 x d
Combustion behavior	Flame resistant and self-extinguishing in accordance with IEC 60332-1-2, -2-2
Length	8...30 m
Color coding	Based on DIN 47100, see Table 13.

Table 14: Cable Data

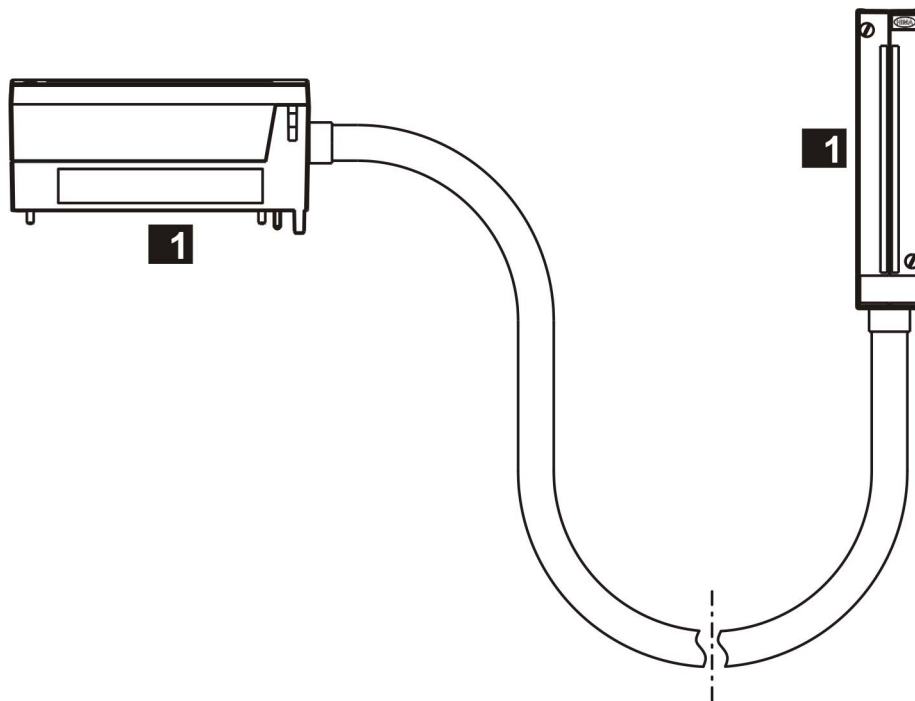

1 Identical Cable Plugs

Figure 8: System Cable X-CA 011 01 n

The system cable is available in four variants, see table:

System Cable	Description	Length
X-CA 011 01 8	Coded cable plugs on both sides	8 m
X-CA 011 01 15		15 m
X-CA 011 01 30		30 m

Table 15: Available System Cables

3.7.1 Cable Plug Coding

The cable plugs are equipped with three coding pins. Cable plugs only match connector boards and FTAs with the corresponding recesses.

4 Start-up

This chapter describes how to install, configure and connect the module. For more information, refer to the Safety Manual (HI 801 003 E).

4.1 Mounting

Observe the following points when mounting the module:

- Only operate the module with the appropriate fan components. For more information, see the System Manual (HI 801 001 E).
- Only operate the module with the suitable connector board. For more information, see Chapter 3.6.
- The module and its connected components must be mounted to provide protection of at least IP20 in accordance with EN 60529: 1991 + A1: 2000.

NOTE



Damage due to incorrect wiring!

Failure to comply with these instructions can damage the electronic components.

Observe the following points:

- Plugs and terminals connected to the field zone.
 - Take the appropriate earthing measures when connecting the plugs and terminals to the field zone.
 - Use shielded cables with twisted pairs.
 - Connect one twisted pair of the shielded cable to each of the analog measurement inputs.
 - On the module side, the shielding must be connected to the cable shield rail (use SK 20 shield connection terminal block or similar).
 - When using stranded wires, HIMA recommends fastening ferrules to the wire ends. The terminals must be suitable for fastening the cross-sections of the cables in use.

4.1.1 Wiring Outputs not in Use

Outputs that are not being used may stay open and need not be terminated. To prevent short-circuits in the field zone, never connect a wire to a connector board if it is open on the field side.

4.2 Mounting and Removing the Module

When replacing an existing module or mounting a new one, follow the instructions given in this chapter.

When removing the module, the connector board remains in the HIMax base plate. This saves additional wiring effort since all field terminals are connected via the connector board of the module.

4.2.1 Mounting a Connector Board

Tools and utilities

- Screwdriver, slotted 0.8 x 4.0 mm
- Matching connector board

To install the connector board

1. Insert the connector board into the guiding rail with the groove facing upwards (see following figure). Fit the groove into the guiding rail pin.
2. Place the connector board on the cable shield rail.
3. Secure the two captive screws to the base plate. First screw in the lower than the upper screw.

To remove the connector board

1. Release the captive screws from the base plate.
2. Lift the lower section of the connector board from the cable shield rail.
3. Remove the connector board from the guiding rail.

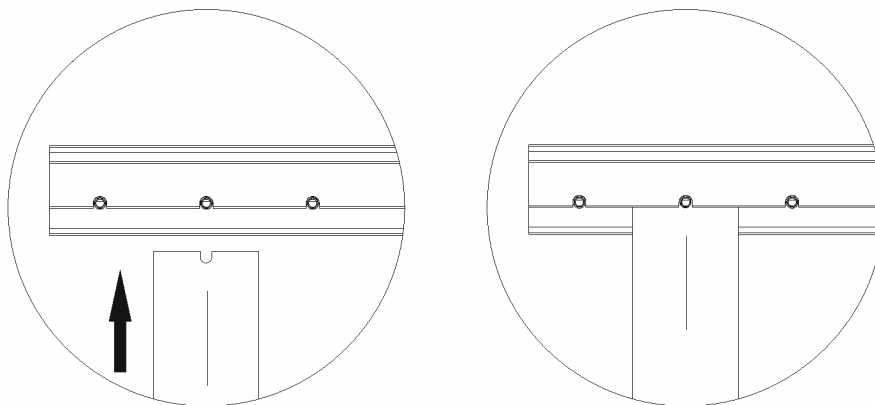

Figure 9: Inserting the Connector Board

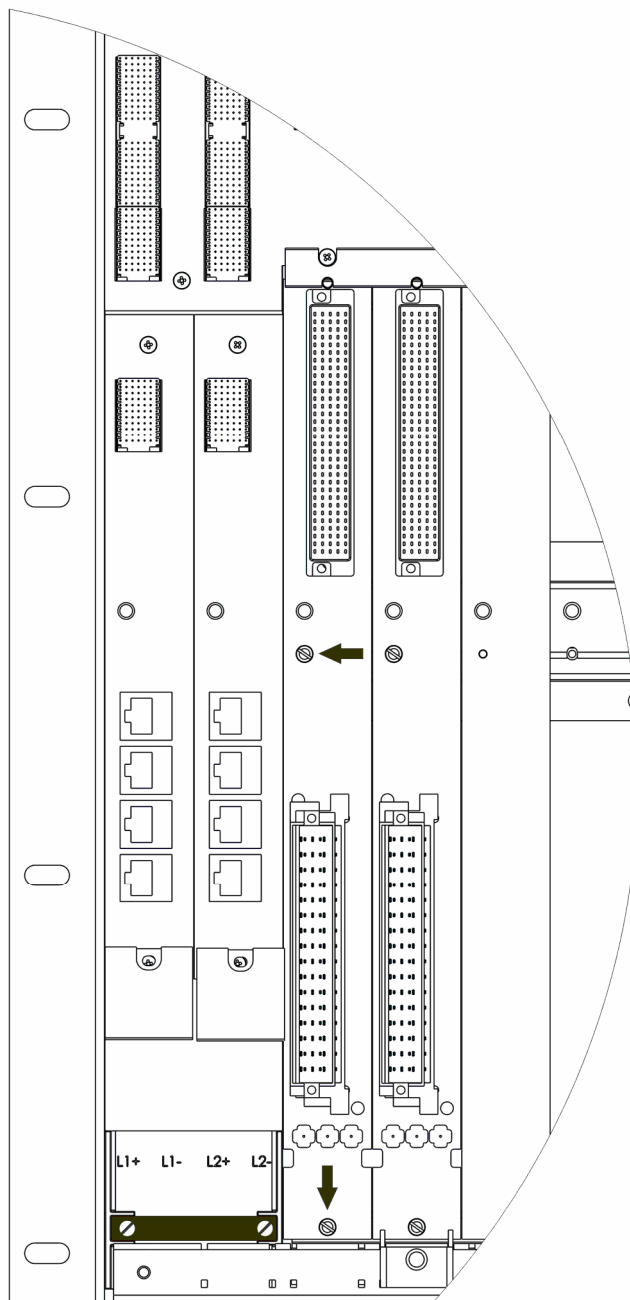

Figure 10: Securing the Connector Board with Captive Screws

4.2.2 Mounting and Removing the Module

This chapter describes how to mount and remove the HIMax module. A module can be mounted and removed while the HIMax system is operating.

NOTICE



Damage to bus and power sockets due to module jamming!
Failure to observe this can damage the controller.
Always take care when inserting the module in the base plate.

Tools and utilities

- Screwdriver, slotted 0.8 x 4.0 mm
- Screwdriver, slotted 1.2 x 8.0 mm

Installation

1. Open the cover plate on the fan rack:
 - Move the locks to the *open* position.
 - Lift the cover plate and insert into the fan rack
2. Insert the top of the module into the hook-in rail, see **1**.
3. Swivel the lower edge of the module towards the base plate and apply light pressure to snap it into place, see **2**.
4. Tighten the screws, see **3**.
5. Pull the cover plate out of the fan rack and close it.
6. Lock the cover plate.

Removal

1. Open the cover plate on the fan rack:
 - Move the locks to the *open* position.
 - Lift the cover plate and insert into the fan rack
2. Release the screw **3**.
3. Swivel the lower edge of the module away from the base plate. Lift and apply light pressure to remove the module from the hook-in rail, see **2** and **1**.
4. Pull the cover plate out of the fan rack and close it.
5. Lock the cover plate.

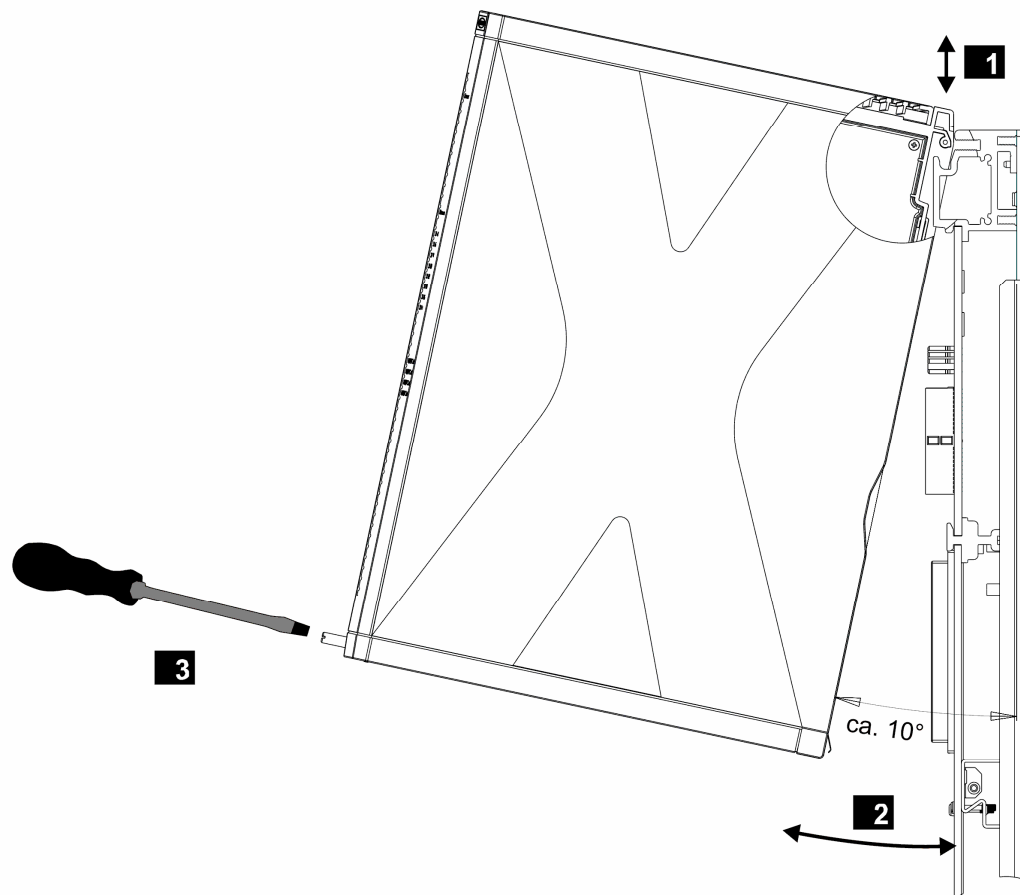

- 1** Inserting and Removing a Module **3** Securing and Releasing a Module
2 Swiveling a Module in and out

Figure 11: Mounting and Removing a Module

i If the HIMax system is operating, do not open the cover plate of the fan rack for more than a few minutes (< 10 min) since this affects the forced cooling.

4.3 Configuring the Module in SILworX

The module is configured in the Hardware Editor of the SILworX programming tool.

Observe the following points when configuring the module:

- To diagnose the module and channels, both the statuses and the measured value can be evaluated within the user program. For more information on the statuses and parameters, refer to the tables starting with Chapter 4.3.

To evaluate the system parameters from within the user program, assign the module's system parameters global variables. Perform this step in the Hardware Editor using the detail view of the module.

The following tables present the statuses and parameters for the module in the same order given in the SILworX Hardware Editor.

TIP To convert hexadecimal values to bit strings a scientific calculator such as the Windows[®] calculator with the corresponding view can be used.

4.3.1 Tab: Module

The **Module** tab contains the system parameters for the module:

Name	R/W	Description																															
Enter these statuses and parameters directly in the Hardware Editor.																																	
Name	W	Module name																															
Noise Blanking	W	Noise blanking performed by processor module allowed (activated/deactivated). Default setting: Activated Status acknowledgments are suppressed until the safety time. The user program retains its last valid process value.																															
Name	Data type	R/W	Description																														
The following statuses and parameters can be assigned global variables and used in the user program.																																	
Module OK	BOOL	R	TRUE: Mono operation: No module faults. FALSE: Module fault Channel fault (external faults included) The module is not plugged in. Observe the <i>Module Status</i> parameter!																														
Module Status	DWORD	R	Status of the module																														
			<table border="1"> <thead> <tr> <th>Coding</th> <th>Description</th> </tr> </thead> <tbody> <tr> <td>0x00000001</td> <td>Module fault</td> </tr> <tr> <td>0x00000002</td> <td>Temperature threshold 1 exceeded</td> </tr> <tr> <td>0x00000004</td> <td>Temperature threshold 2 exceeded</td> </tr> <tr> <td>0x00000008</td> <td>Incorrect temperature value</td> </tr> <tr> <td>0x00000010</td> <td>Voltage on L1+ is defective</td> </tr> <tr> <td>0x00000020</td> <td>Voltage on L2+ is defective</td> </tr> <tr> <td>0x00000040</td> <td>Internal voltage defective</td> </tr> <tr> <td>0x02000000</td> <td>Fault in an FPGA header</td> </tr> <tr> <td>0x04000000</td> <td>Error during monitoring of 2.5 V.</td> </tr> <tr> <td>0x08000000</td> <td>Error during monitoring of 3.3 V.</td> </tr> <tr> <td>0x10000000</td> <td>Error during monitoring of 1.2 V.</td> </tr> <tr> <td>0x20000000</td> <td>Error during monitoring of 15 V.</td> </tr> <tr> <td>0x40000000</td> <td>Error during monitoring of 24 V.</td> </tr> <tr> <td>0x80000000</td> <td>No connection to the module.</td> </tr> </tbody> </table>	Coding	Description	0x00000001	Module fault	0x00000002	Temperature threshold 1 exceeded	0x00000004	Temperature threshold 2 exceeded	0x00000008	Incorrect temperature value	0x00000010	Voltage on L1+ is defective	0x00000020	Voltage on L2+ is defective	0x00000040	Internal voltage defective	0x02000000	Fault in an FPGA header	0x04000000	Error during monitoring of 2.5 V.	0x08000000	Error during monitoring of 3.3 V.	0x10000000	Error during monitoring of 1.2 V.	0x20000000	Error during monitoring of 15 V.	0x40000000	Error during monitoring of 24 V.	0x80000000	No connection to the module.
			Coding	Description																													
			0x00000001	Module fault																													
			0x00000002	Temperature threshold 1 exceeded																													
			0x00000004	Temperature threshold 2 exceeded																													
			0x00000008	Incorrect temperature value																													
			0x00000010	Voltage on L1+ is defective																													
			0x00000020	Voltage on L2+ is defective																													
			0x00000040	Internal voltage defective																													
			0x02000000	Fault in an FPGA header																													
			0x04000000	Error during monitoring of 2.5 V.																													
			0x08000000	Error during monitoring of 3.3 V.																													
			0x10000000	Error during monitoring of 1.2 V.																													
			0x20000000	Error during monitoring of 15 V.																													
0x40000000	Error during monitoring of 24 V.																																
0x80000000	No connection to the module.																																
¹⁾ These faults affect the <i>Module OK</i> status and need not be separately evaluated in the user program.																																	
Timestamp [µs]	DWORD	R	Microsecond fraction of the timestamp. Point in time at which the analog outputs were measured.																														
Timestamp [s]	DWORD	R	Second fraction of the timestamp. Point in time at which the analog outputs were measured.																														

Table 16: Module Tab in the Hardware Editor

4.3.2 Tab: I/O Submodule AO16_01

The I/O Submodule AO16 01 tab contains the following system parameters:

Name		R/W	Description
Enter these statuses and parameters directly in the Hardware Editor.			
Name		R	Module name
Name	Data type	R/W	Description
The following statuses and parameters can be assigned global variables and used in the user program.			
Background Test Error	BOOL	R	TRUE: Background test is faulty, monitor the module, if required, prepare replacement FALSE: Background test is free of faults
Diagnostic Request	DINT	W	To request a diagnostic value, the appropriate ID must be sent to the module using the parameter <i>Diagnostic Request</i> (see Chapter 4.3.5 for coding details).
Diagnostic Response	DINT	R	As soon as <i>Diagnostic Response</i> returns the ID of <i>Diagnostic Request</i> (see 4.3.5 for coding details), <i>Diagnostic Status</i> contains the diagnostic value requested.
Diagnostic Status	DWORD	R	Requested diagnostic value in accordance with <i>Diagnostic Response</i> . The IDs of <i>Diagnostic Request</i> and <i>Diagnostic Response</i> can be evaluated in the user program. <i>Diagnostic Status</i> only contains the requested diagnostic value when both <i>Diagnostic Request</i> and <i>Diagnostic Response</i> have the same ID.
Restart on Error	BOOL	W	Using the parameter <i>Restart on Error</i> , each I/O module that has switched off permanently due to faults can be forced to re-adopt the RUN state. To do this, set the <i>Restart on Error</i> parameter FALSE to TRUE. The I/O module performs a complete self-test and only enters the RUN state if no faults are detected. Default setting: FALSE
Submodule OK	BOOL	R	TRUE: No submodule fault. No channel faults. FALSE: Submodule fault. Channel fault (external faults included)
Submodule Status	DWORD	R	Bit-coded submodule status (For coding details, see Chapter 4.3.4)

Table 17: Tab: I/O Submodule AO16_01 in the Hardware Editor

4.3.3 Tab: I/O Submodule AO16_01: Channels

The **I/O Submodule AO16_01: Channels** tab contains the following system parameters for each analog output.

Global variables can be assigned to the system parameters with -> and used in the user program. The value without -> must be directly entered.

Name	Data type	R/W	Description
Channel no.	---	R	Channel number, defined by default
Process Value [REAL] ->	REAL	R	<p>Process value converted to a current value using the intermediate data points 4 mA and 20 mA.</p> <hr/> <p>i The process value 0.0 results in an output current, if it is contained between the two intermediate data points (e.g., 4 mA = -60.0 and 20 mA = +60.0). This also applies if no global variable is connected to the <i>Process Value</i> -> parameter.</p> <hr/>
4 mA	REAL	W	<p>Intermediate data point on the lowest scale final value (4 mA) of the channel. Enter the process value for which 4 mA should be output to the output. Default setting: 4.0</p> <hr/> <p>i If the channel is not used, maintain the default setting 4.0.</p> <hr/>
20 mA	REAL	W	<p>Intermediate data point on the highest scale final value (20 mA) of the channel. Enter the process value for which 20 mA should be output to the output. Default setting: 20.0</p> <hr/> <p>i If the channel is not used, maintain the default setting 20.0.</p> <hr/>
-> Channel OK	BOOL	R	<p>TRUE: Faultless channel The output value is valid. FALSE: Faulty channel The output value is set to 0.</p>

Table 18: Tab: I/O Submodule AO16_01:Channels in the Hardware Editor

4.3.4 Submodule Status [DWORD]

Coding of the **Submodule Status**

Coding	Description
0x00000001	Fault in hardware unit (submodule).
0x00000002	Reset of an I/O bus
0x00000004	Faults detected while configuring the hardware
0x00000008	Fault detected while verifying the coefficients
0x00000010	First temperature threshold exceeded (warning temperature)
0x00000020	Second temperature threshold exceeded (limit temperature)
0x00000040	Module shutdown due to overcurrent
0x00000080	Reset of the chip select monitoring

Table 19: Submodule Status [DWORD]

4.3.5 Diagnostic Status [DWORD]

Coding of **Diagnostic Status**

ID	Description										
0	Diagnostic values (100...1016) are displayed consecutively.										
100	Bit-coded temperature status 0 = normal Bit0 = 1 : Temperature threshold 1 has been exceeded Bit1 = 1 : Temperature threshold 2 has been exceeded Bit2 = 1 : Fault in temperature measurement										
101	Measured temperature (10 000 Digit/ °C)										
200	Bit-coded voltage status 0 = normal Bit0 = 1 : L1+ (24 V) is faulty Bit1 = 1 : L2+ (24 V) is faulty										
201	Not used!										
202											
203											
300	Comparator 24 V low voltage (BOOL)										
1001...1016	Status of the channels 1...16 <table border="1" style="margin-left: 20px;"> <thead> <tr> <th>Coding</th> <th>Description</th> </tr> </thead> <tbody> <tr> <td>0x0001</td> <td>Fault in hardware unit</td> </tr> <tr> <td>0x0002</td> <td>Channel fault due to internal fault</td> </tr> <tr> <td>0x0100</td> <td>The measured values are out of the safety-related accuracy range.</td> </tr> <tr> <td>0x0200</td> <td>Limit values are exceeded.</td> </tr> </tbody> </table>	Coding	Description	0x0001	Fault in hardware unit	0x0002	Channel fault due to internal fault	0x0100	The measured values are out of the safety-related accuracy range.	0x0200	Limit values are exceeded.
Coding	Description										
0x0001	Fault in hardware unit										
0x0002	Channel fault due to internal fault										
0x0100	The measured values are out of the safety-related accuracy range.										
0x0200	Limit values are exceeded.										

Table 20: Diagnostic Status [DWORD]

4.4 Connection Variants

This chapter describes the correct wiring of the module in safety-related applications. The connection variants specified here are permitted.

The outputs are wired via connector boards.

4.4.1 Single-Channel Output Wiring

Connector boards X-CB 014 51 (with screw terminals) or X-CB 014 53 (with cable plug) can be used to perform the wiring such as described in Figure 12.

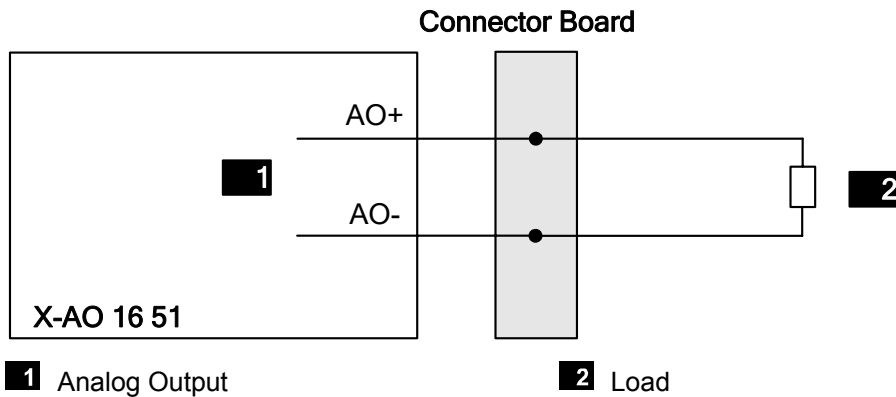

Figure 12: Single-Channel Wiring

4.4.2 Closed-Loop Control

A physical coupling exists between the actuator of the analog output AO and the readings recorder of the analog input AI. The data measured for the analog input are processed in the processor module and become the new data for the analog output.

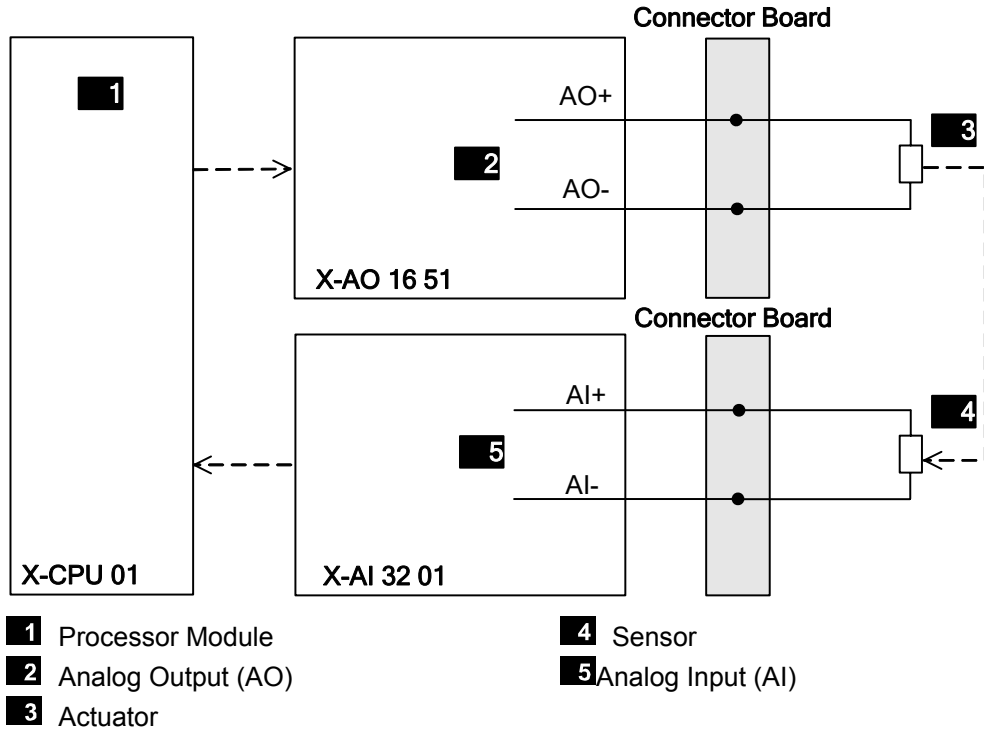

Figure 13: Closed Loop Connection

i

Potential delays due to process data processing of the HIMax controller must be taken into account.

4.4.3 Connection via Field Termination Assembly

The connection via the X-FTA 002 01 is performed as described in Figure 14:.. For further information, refer to the manuals specific to the X-FTA 002 01 and X-FTA 009 02L.

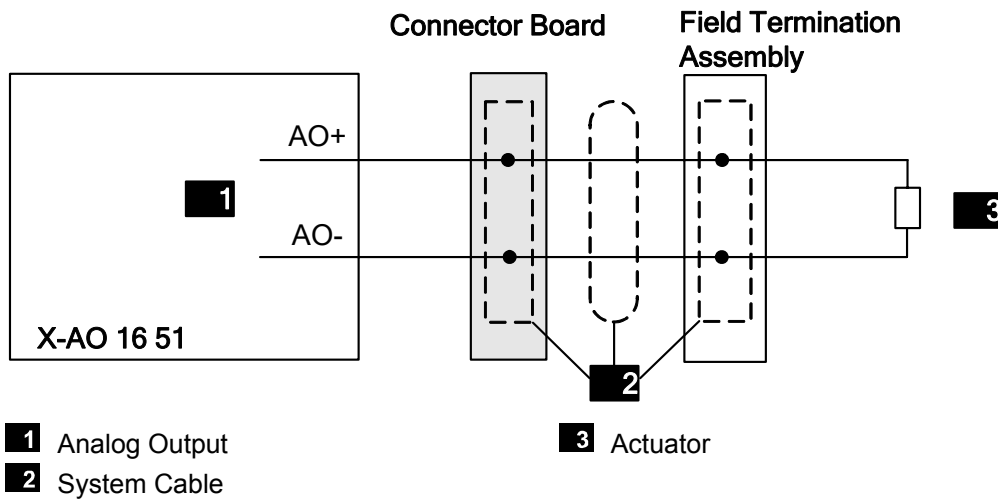

Figure 14: Connection via Field Termination Assembly

4.4.4 Characteristics of HART Communication

To ensure HART communication, a HART handheld can be connected in parallel to the actuator. The current fluctuation caused by the HART communications is extensively compensated by the analog output so that the maximum residual error of the preset current is 2 % of the final value.

i Higher residual error with HART communication. Remove the HART terminal directly after the diagnosis!

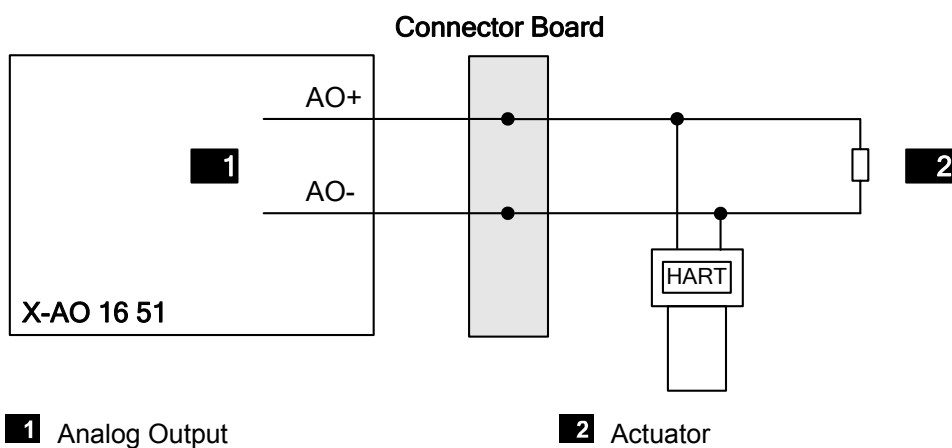

Figure 15: HART Handheld in Parallel to the Transmitter and Output Module

5 Operation

The module runs within a HIMax base plate and does not require any specific monitoring.

5.1 Handling

Direct handling of the module is not foreseen.

The module is operated from within the PADT, e.g., for forcing the analog outputs. For more details, refer to the SILworX documentation.

5.2 Diagnosis

LEDs on the front side of the module indicate the module state, see Chapter 3.4.2.

The diagnostic history of the module can also be read using SILworX. Chapter 4.3.4 and Chapter 4.3.5 describe the most important diagnostic statuses.

i

If a module is plugged in to a base plate, it generates diagnostic messages during its initialization phase indicating faults such as incorrect voltage values.

If these messages only occur before the entire system is operated, they do not indicate a module fault.

6 Maintenance

Defective modules must be replaced with a faultless module of the same type or with an approved replacement model.

Only the manufacturer is authorized to repair the module.

When replacing modules, observe the instructions specified in the System Manual (HI 801 001 E) and Safety Manual (HI 801 003 E).

6.1 Maintenance Measures

6.1.1 Loading the Operating System

HIMA is continuously improving the operating system of the module. HIMA recommends to use system downtimes to load the current version of the operating system into the module.

For detailed instructions on how to load the operating system, see the system manual and the online help. The module must be in STOP to be able to load an operating system.

i

The current version of the module in use is displayed in the SILworX Control Panel! The type label specifies the version when the module is delivered, see Chapter 3.3.

6.1.2 Proof Test

HIMax modules must be subjected to a proof test in intervals of 10 years. For more information, refer to the Safety Manual HI 801 003 E.

7 Decommissioning

To decommission the module, remove it from the base plate. For more information, see *Mounting and Removing the Module*.

8 Transport

To avoid mechanical damage, HIMax components must be transported in packaging.

Always store HIMax components in their original product packaging. This packaging also provides protection against electrostatic discharge. Note that the product packaging alone is not suitable for transport.

9 Disposal

Industrial customers are responsible for correctly disposing of decommissioned HIMax hardware. Upon request, a disposal agreement can be arranged with HIMA.

All materials must be disposed of in an ecologically sound manner.

Appendix

Glossary

Term	Description
ARP	Address Resolution Protocol: Network protocol for assigning the network addresses to hardware addresses
AI	Analog Input
Connector Board	Connector board for the HIMax module
COM	Communication module
CRC	Cyclic Redundancy Check
DI	Digital Input
DO	Digital Output
EMC	Electromagnetic Compatibility
EN	European Norm
ESD	ElectroStatic Discharge
FB	Fieldbus
FBD	Function Block Diagram
FTT	Fault Tolerance Time
ICMP	Internet Control Message Protocol: Network protocol for status or error messages
IEC	International Electrotechnical Commission
MAC address	Hardware address of one network connection (Media Access Control)
PADT	Programming And Debugging Tool (in accordance with IEC 61131-3), PC with SILworX
PE	Protective Earth
PELV	Protective Extra Low Voltage
PES	Programmable Electronic System
PFD	Probability of Failure on Demand, probability of failure on demand of a safety function
PFH	Probability of Failure per Hour, probability of a dangerous failure per hour
R	Read
Rack ID	Base plate identification (number)
Non-reactive	Supposing that two input circuits are connected to the same source (e.g., a transmitter). An input circuit is termed "non-reactive" if it does not distort the signals of the other input circuit.
R/W	Read/Write
SB	System Bus (Module)
SELV	Safety Extra Low Voltage
SFF	Safe Failure Fraction, portion of safely manageable faults
SIL	Safety Integrity Level (in accordance with IEC 61508)
SILworX	Programming tool for HIMax
SNTP	Simple Network Time Protocol (RFC 1769)
SRS	System.Rack.Slot addressing of a module
SW	Software
TMO	TiMeOut
TMR	Triple Module Redundancy
W	Write
r_p	Peak value of a total AC component
Watchdog (WD)	Time monitoring for modules or programs. If the watchdog time is exceeded, the module or program enters the ERROR STOP state.
WDT	WatchDog Time

Index of Figures

Figure 1: Sample Type Label	11
Figure 2: Block Diagram	12
Figure 3: Indicators	13
Figure 4: Views	16
Figure 5: Coding Example	19
Figure 6: Connector Boards with Screw Terminals	20
Figure 7: Connector Boards with Cable Plug	22
Figure 8: System Cable X-CA 011 01 n	24
Figure 9: Inserting the Connector Board	27
Figure 10: Securing the Connector Board with Captive Screws	28
Figure 11: Mounting and Removing a Module	30
Figure 12: Single-Channel Wiring	36
Figure 13: Closed Loop Connection	37
Figure 14: Connection via Field Termination Assembly	38
Figure 15: HART Handheld in Parallel to the Transmitter and Output Module	38

Index of Tables

Table 1:	Additional Relevant Manuals	5
Table 2:	Environmental Requirements	8
Table 3:	Blinking Frequencies of LEDs	14
Table 4:	Module Status Indicators	14
Table 5:	System Bus Indicators	15
Table 6:	I/O LEDs	15
Table 7:	Product Data	16
Table 8:	Specifications for the Analog Outputs	17
Table 9:	Available Connector Boards	18
Table 10:	Position of Coding Wedges	19
Table 11:	Terminal Assignment for Mono Connector Boards with Screw Terminals	21
Table 12:	Cable Plug Properties	21
Table 13:	Pin Assignment for Mono Connector Boards with Cable Plug	23
Table 14:	Cable Data	24
Table 15:	Available System Cables	24
Table 16:	Module Tab in the Hardware Editor	32
Table 17:	Tab: I/O Submodule AO16_01 in the Hardware Editor	33
Table 18:	Tab: I/O Submodule AO16_01:Channels in the Hardware Editor	34
Table 19:	Submodule Status [DWORD]	35
Table 20:	Diagnostic Status [DWORD]	35

Index

block diagram.....	12	HART communication.....	38
Connector Board		module status indicators.....	14
with Screw Terminals	20	product data	
connector boards		module	16
with cable plug.....	22	safety function	10
diagnosis.....	39	specifications	
I/O indicators	15	outputs	17
system bus indicators.....	15		

HI 801 187 E

© 2011 HIMA Paul Hildebrandt GmbH + Co KG
HIMax and SILworX are registered trademark of:
HIMA Paul Hildebrandt GmbH + Co KG

Albert-Bassermann-Str. 28
68782 Brühl, Germany
Phone +49 6202 709-0
Fax +49 6202 709-107
HIMax-info@hima.com
www.hima.com



SAFETY
NONSTOP