



WSE27-3R2631

W27-3

COMPACT PHOTOELECTRIC SENSORS

SICK
Sensor Intelligence.



Illustration may differ

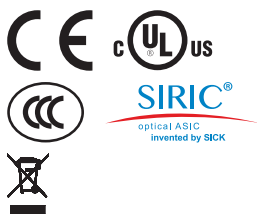

Ordering information

Type	Part no.
WSE27-3R2631	1027795

Other models and accessories → www.sick.com/W27-3

Detailed technical data

Features

Sensor/ detection principle	Through-beam photoelectric sensor
Dimensions (W x H x D)	24.6 mm x 80.6 mm x 54 mm
Housing design (light emission)	Rectangular
Sensing range max.	0 m ... 35 m
Sensing range	0 m ... 25 m
Type of light	Visible red light
Light source	LED ¹⁾
Light spot size (distance)	Ø 600 mm (25 m)
Angle of dispersion	Approx. 1.5°
Wave length	645 nm
Adjustment	Potentiometer

¹⁾ Average service life: 100,000 h at T_J = +25 °C.

Mechanics/electronics

Supply voltage	20 V AC/DC ... 250 V AC/DC ¹⁾
Power consumption	≤ 5.5 VA

¹⁾ Limit values.

²⁾ Provide suitable arc suppression for inductive or capacitive loads. Relay contacts are separated from the supply voltage by a basic isolation of 3 mm. Depending on the application, additional isolation might have to be applied in the user's circuit.

³⁾ With light/dark ratio 1:1.

⁴⁾ A = V_S connections reverse-polarity protected.

⁵⁾ C = interference suppression.

⁶⁾ Reference voltage: 250 V AC, overvoltage category 2.

⁷⁾ UL: 0 °C ... +60 °C.

Switching output	Relay, electrically isolated ²⁾
Output function	Change-over contacts
Switching mode	Light/dark switching
Switching mode selector	Selectable via time delay selector switch
Switching current (switching voltage)	4 A @ 250 V AC, 4 A @ 24 V DC, 0.125 A @ 250 V DC UL: 4 A @ 250 V AC, general use / 4 A @ 250 V AC, resistive (NO) / 3 A @ 250 V AC, resistive (NC) / 4 A @ 24 V DC, NO, general use / 3 A @ 24 V DC, NC, general use / R300 / B300 (NO contacts only) / 0 °C ... +60 °C
Response time	≤ 10 ms
Switching frequency	10 Hz ³⁾
Angle of reception	Approx. 3°
Time functions	On delay Off delay Switch on delay and time delay off
Delay time	Adjustable via time delay selector switch, 0.5 s ... 10 s
Connection type	Connector Q6, 6-pin, AC/UC-coding
Circuit protection	A ⁴⁾ C ⁵⁾
Protection class	II ⁶⁾
Weight	240 g
Housing material	Plastic, ABS
Optics material	Plastic, PMMA
Enclosure rating	IP65
Usage category	AC-15, DC-13, according to EN 60947-1
Ambient operating temperature	-40 °C ... +60 °C ⁷⁾
Ambient storage temperature	-40 °C ... +75 °C
UL File No.	NRKH.E181493 & NRKH7.E181493
Part number of individual components	2033597 WS27-3U2630 2038939 WE27-3R2631

¹⁾ Limit values.

²⁾ Provide suitable arc suppression for inductive or capacitive loads. Relay contacts are separated from the supply voltage by a basic isolation of 3 mm. Depending on the application, additional isolation might have to be applied in the user's circuit.

³⁾ With light/dark ratio 1:1.

⁴⁾ A = V_S connections reverse-polarity protected.

⁵⁾ C = interference suppression.

⁶⁾ Reference voltage: 250 V AC, overvoltage category 2.

⁷⁾ UL: 0 °C ... +60 °C.

Safety-related parameters

MTTF_D	443 years
DC_{avg}	0%

Classifications

ECl@ss 5.0	27270901
ECl@ss 5.1.4	27270901
ECl@ss 6.0	27270901
ECl@ss 6.2	27270901

ECl@ss 7.0	27270901
ECl@ss 8.0	27270901
ECl@ss 8.1	27270901
ECl@ss 9.0	27270901
ECl@ss 10.0	27270901
ECl@ss 11.0	27270901
ETIM 5.0	EC002716
ETIM 6.0	EC002716
ETIM 7.0	EC002716
UNSPSC 16.0901	39121528

Connection diagram

Cd-159

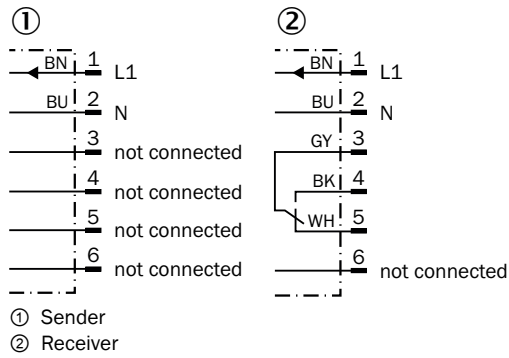

Characteristic curve

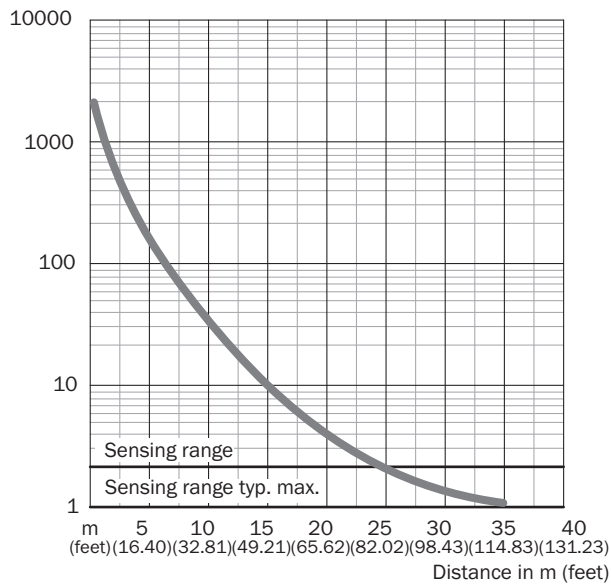

Sensing range diagram

WSE27-3

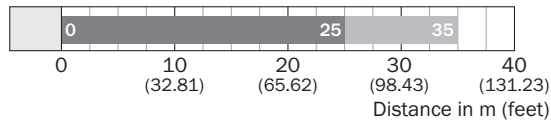

■ Sensing range ■ Sensing range typ. max.

Adjustments possible

Potentiometer, time functions, light-/dark-switch

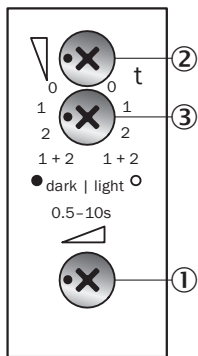

- ① Potentiometer
- ② Time control
- ③ Time delay selector switch

Dimensional drawing (Dimensions in mm (inch))

WL27-3, WSE27-3, potentiometer, time functions

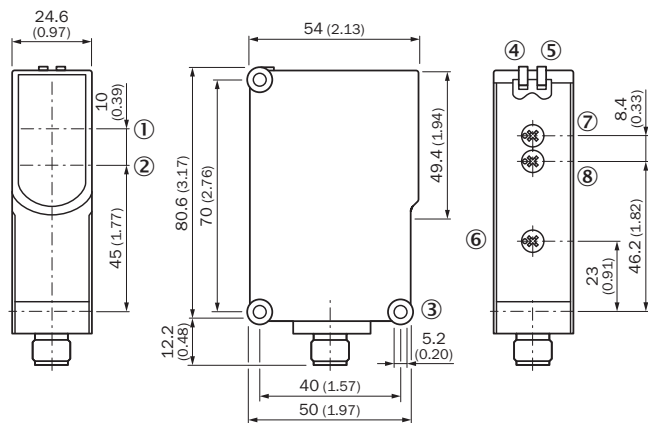

- ① Optical axis, sender
- ② Optical axis, receiver
- ③ Mounting hole \varnothing 5.2 mm
- ④ LED indicator green: Supply voltage active
- ⑤ LED indicator yellow: Status of received light beam
- ⑥ Sensitivity control (10 revolutions)
- ⑦ Time control
- ⑧ Time delay selector switch

SICK AT A GLANCE

SICK is one of the leading manufacturers of intelligent sensors and sensor solutions for industrial applications. A unique range of products and services creates the perfect basis for controlling processes securely and efficiently, protecting individuals from accidents and preventing damage to the environment.

We have extensive experience in a wide range of industries and understand their processes and requirements. With intelligent sensors, we can deliver exactly what our customers need. In application centers in Europe, Asia and North America, system solutions are tested and optimized in accordance with customer specifications. All this makes us a reliable supplier and development partner.

Comprehensive services complete our offering: SICK LifeTime Services provide support throughout the machine life cycle and ensure safety and productivity.

For us, that is “Sensor Intelligence.”

WORLDWIDE PRESENCE:

Contacts and other locations –www.sick.com