

# AC2916

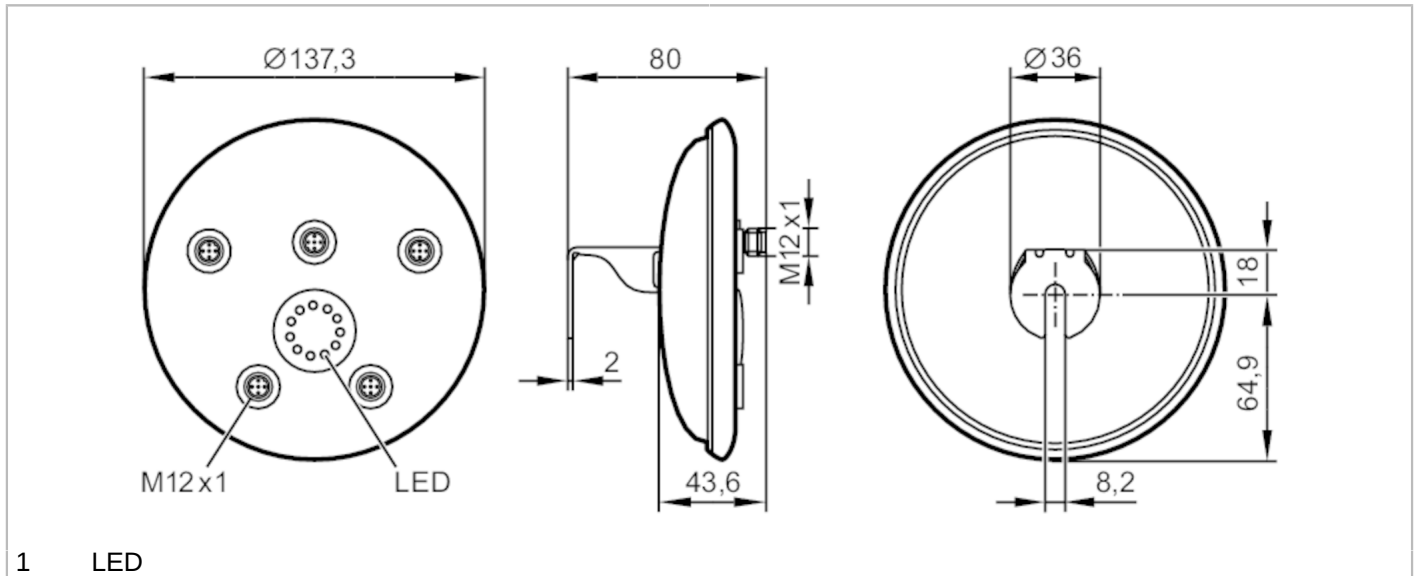

## AS-Interface ProcessLine module

ProcessLine 4AI C IP69K



Application	
Application	for hygienic and wet areas in the food industry
Electrical data	
Operating voltage [V]	26.5...31.6 DC
Max. current consumption from AS-i [mA]	450
Reverse polarity protection	yes
Inputs / outputs	
Number of inputs and outputs	Number of analogue inputs: 4
Inputs	
Sensor supply of the inputs	AS-i
Digital inputs protected against short circuits	yes
Number of analogue inputs	4; (connection of 2- and 3-wire sensors)
Analogue input (current) [mA]	4...20
Max. voltage drop across load for nominal voltage [V]	10
Resolution of analogue input	1 bit = 1 µA
Precision analogue input [%]	0,5
Outputs	
Precision analogue output [%]	MEW
Operating conditions	
Ambient temperature [°C]	-5...70
Protection	IP 68; IP 69K
Tests / approvals	
EMC	EN 62026-2
	EN 61000-6-2
MTTF [years]	98

# AC2916



## AS-Interface ProcessLine module

ProcessLine 4AI C IP69K

AS-i classification	
AS-i version	2.11; 3.0
Extended addressing mode	no
AS-i profile	S-7.3.E
AS-i I/O configuration [hex]	7
AS-i ID code [hex]	3.E
AS-i certificate	101108

Mechanical data	
Weight [g]	607
Dimensions [mm]	Ø 137.3 / L = 80
Materials	threaded bush: stainless steel (1.4404 / 316L); PC; O-ring: EPDM

Displays / operating elements		
Display	operation	LED, green Voltage AS-i
	errors	LED, red
	function	LED, yellow channels AI1...AI4

Electrical connection	
AS-i bus connection	M12

Accessories	
Accessories (optional)	Protective cap: M12, E70297
	Flat cable insulation displacement connector:, E70454
	Torque wrench:, E70390
	Flat cable insulation displacement connector:, E70453

Remarks	
Remarks	When the sensors and actuators are supplied from AS-i the load must not exceed a maximum of 380 mA.
	The load for an individual sensor connection must not exceed 200 mA.
	There is an electrical connection between the sensor and AS-i.
Pack quantity	MEW = % of the final value of the measuring range 1 pcs.

### Electrical connection - AS-i

Connector: 1 x M12

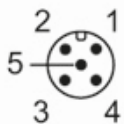

- 1: AS-i +
- 2: n.c.
- 3: AS-i -
- 4: n.c.
- 5: functional earth (FE)

# AC2916



## AS-Interface ProcessLine module

ProcessLine 4AI C IP69K

### Electrical connection - Process connection

Connector: 4 x M12



	Inputs
1	Sensor supply + 24 V
2	AI+
3	Sensor supply 0 V / AI-
4	n.c.
5	functional earth (FE)