

AL1121

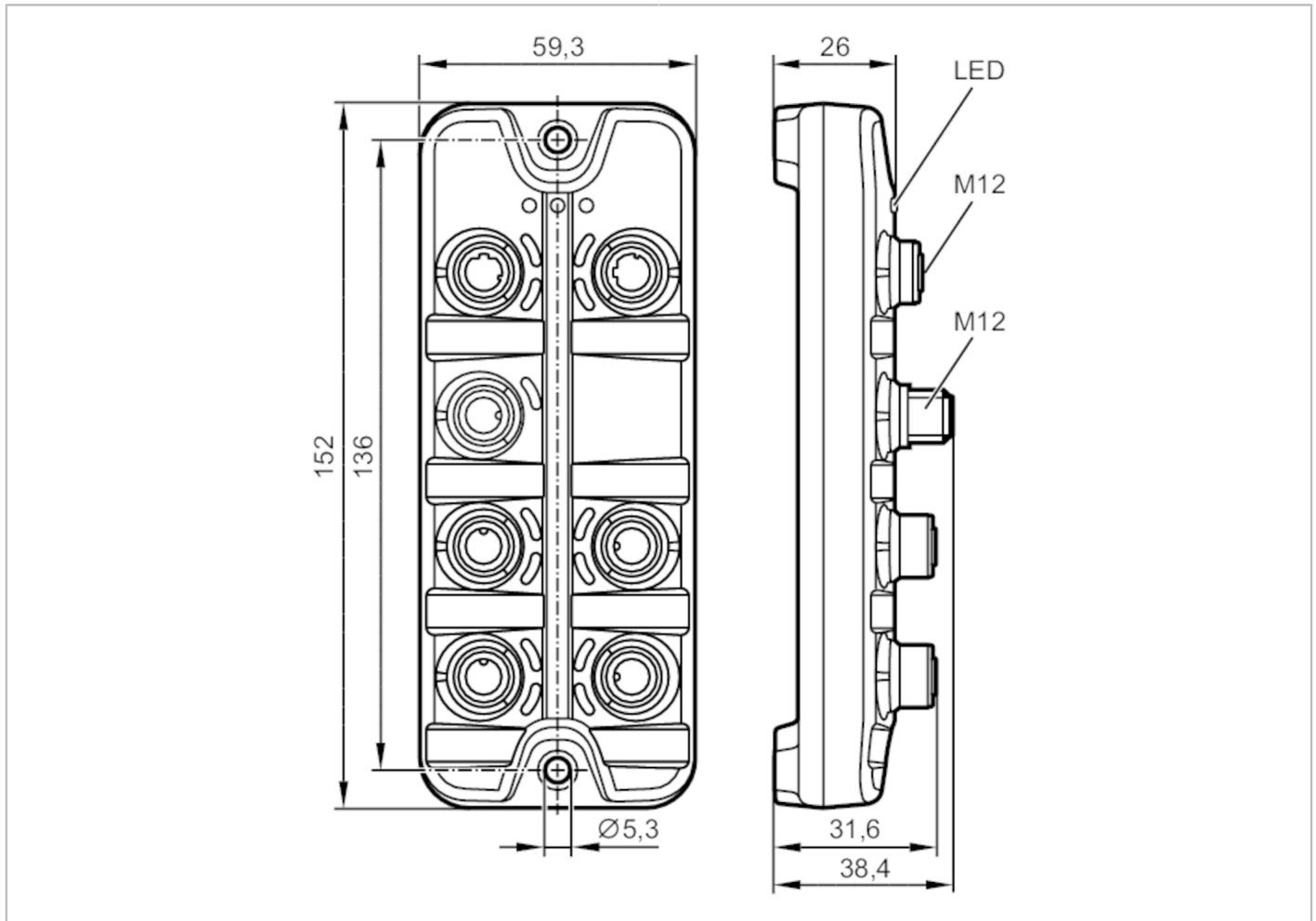

IO-Link master with EtherNet/IP interface

IO-Link Master SL EIP 4P IP69K



Application	
Application	hygienic systems; I/O modules for field applications
Daisy-chain function	fieldbus interface
Electrical data	
Operating voltage [V]	20...30 DC; (US; to SELV/PELV)
Current consumption [mA]	300...3900; (US)
Protection class	III
Sensor supply US	
Max. current load total [A]	3.6
Inputs / outputs	
Total number of inputs and outputs	8; (configurable)
Number of inputs and outputs	Number of digital inputs: 8; Number of digital outputs: 4



IO-Link master with EtherNet/IP interface

IO-Link Master SL EIP 4P IP69K

Inputs	
Number of digital inputs	8; (IO-Link Port Class A: 4 x 2)
Switching level high [V]	11...30
Switching level low [V]	0...5
Digital inputs protected against short circuits	yes
Outputs	
Number of digital outputs	4; (IO-Link Port Class A: 4 x 1)
Max. current load per output [mA]	300
Short-circuit proof	yes
Interfaces	
Communication interface	Ethernet; IO-Link
Note on interfaces	DHCP
	BOOTP static
	DLR (Device Level Ring)
	Supported network topologies: line
	ring
Ethernet	
Transmission standard	10Base-T; 100Base-TX
Transmission rate	10; 100
Protocol	EtherNet/IP
Factory settings	IP address: 192.168.1.250
	subnet mask: 255.255.255.0
	gateway IP address: 0.0.0.0
	MAC address: see type label
IO-Link Master	
Transmission type	COM1 (4,8 kBaud); COM2 (38,4 kBaud); COM3 (230,4 kBaud)
IO-Link revision	1.1
Number of ports class A	4
Operating conditions	
Ambient temperature [°C]	-25...60
Storage temperature [°C]	-25...85
Max. relative air humidity [%]	90
Protection	IP 65; IP 66; IP 67; IP 69K; (operation with stainless steel protective caps: IP 69K)
Degree of soiling	2
Tests / approvals	
EMC	EN 61000-6-2
	EN 61000-6-4
Shock resistance	DIN EN 60068-2-27
Vibration resistance	DIN EN 60068-2-64 2009-04
	DIN EN 60068-2-6 2008-10
MTTF [years]	96

AL1121



IO-Link master with EtherNet/IP interface

IO-Link Master SL EIP 4P IP69K

Mechanical data

Weight	[g]	273
Materials	housing: PA grey; socket: stainless steel (1.4404 / 316L)	
Sealing material	EPDM / EPDM	

Accessories

Items supplied	Protective cap: 1 x M12, stainless steel, E12542
----------------	--

Remarks

Remarks	For further information please see the operating instructions.
Pack quantity	1 pcs.

Electrical connection - Ethernet

Connector: M12; Sealing: EPDM



IN / OUT X21, X22

1	TX +
2	RX +
3	TX -
4	RX -
5	not used

Electrical connection - Process connection

Connector: M12; Sealing: EPDM

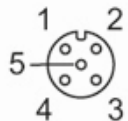

IO-Link Port Class A X01...X04

1	Sensor supply (US) L+
2	digital input
3	Sensor supply (US) L-
4	C/Q IO-Link
5	not used

Electrical connection - voltage supply

Connector: M12

AL1121



IO-Link master with EtherNet/IP interface

IO-Link Master SL EIP 4P IP69K



X31

1	+ 24 V DC (US)
2	not used
3	GND (US)
4	not used