

DI0101

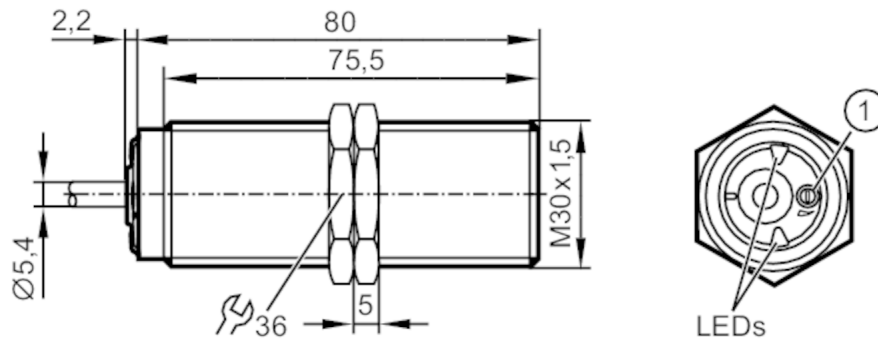

Compact evaluation unit for speed monitoring

DIA2010-ZROA/5-3600 I/MIN



1 potentiometer



Product characteristics

Output function		normally open
Sensing range	[mm]	10
Housing		threaded type
Dimensions	[mm]	M30 x 1.5 / L = 80

Application

Application	simple evaluation of rotating and linear movement with regard to underspeed; blocking
-------------	---

Electrical data

Nominal voltage AC	[V]	20...250
Nominal voltage DC	[V]	20...250
Nominal frequency AC	[Hz]	45...65
Protection class		II
Reverse polarity protection		yes

Outputs

Total number of outputs		1
Output function		normally open
Max. voltage drop switching output DC	[V]	7.5
Minimum load current	[mA]	6
Max. leakage current	[mA]	1.5
Permanent current rating of switching output AC	[mA]	350
Permanent current rating of switching output DC	[mA]	100
Short-time current rating of switching output	[mA]	2200; ((20 ms / 0,5 Hz))
Short-circuit proof		no
Overload protection		no

DI0101



Compact evaluation unit for speed monitoring

DIA2010-ZROA/5-3600 I/MIN

Detection zone		
Sensing range	[mm]	10
Sensing range adjustable		no
Real sensing range Sr	[mm]	10 ± 10 %
Operating distance	[mm]	0...8.1
Measuring/setting range		
Setting range	[Imp/min]	5...3600
Accuracy / deviations		
Correction factor		steel: 1 / stainless steel: 0.8 / brass: 0.5 / aluminium: 0.5 / copper: 0.4
Hysteresis	[% of Sr]	10
Response times		
Start-up delay	[s]	12
Max. damping frequency	[Imp/min]	4800
Software / programming		
Adjustment of the switch point		multiturn potentiometer
Operating conditions		
Ambient temperature	[°C]	-25...80
Storage temperature	[°C]	-25...80
Protection		IP 65; IP 67
Tests / approvals		
EMC		EN 60947-5-2
MTTF	[years]	461
Mechanical data		
Weight	[g]	297.5
Housing		threaded type
Mounting		flush mountable
Dimensions	[mm]	M30 x 1.5 / L = 80
Thread designation		M30 x 1.5
Materials		brass special coating; PA; TPE-U
Tightening torque	[Nm]	50
Displays / operating elements		
Display	switching status	2 x LED, yellow
Electrical connection		
Required protection		miniature fuse to IEC60127-2 sheet 1; ≤ 2 A; fast acting
Accessories		
Items supplied		lock nuts: 2
Remarks		
Remarks		Recommendation Check the safe functioning of the unit after a short circuit.

DI0101



Compact evaluation unit for speed monitoring

DIA2010-ZROA/5-3600 I/MIN

Electrical connection

Cable: 2 m, PUR; 2 x 0.5 mm²

Connection

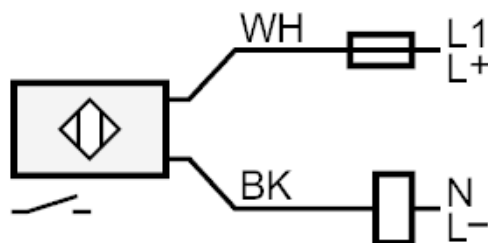

Note miniature fuse to IEC60127-2 sheet 1 \leq 2 A (fast acting)

Core colours :

BK = black

WH = white