

E12502

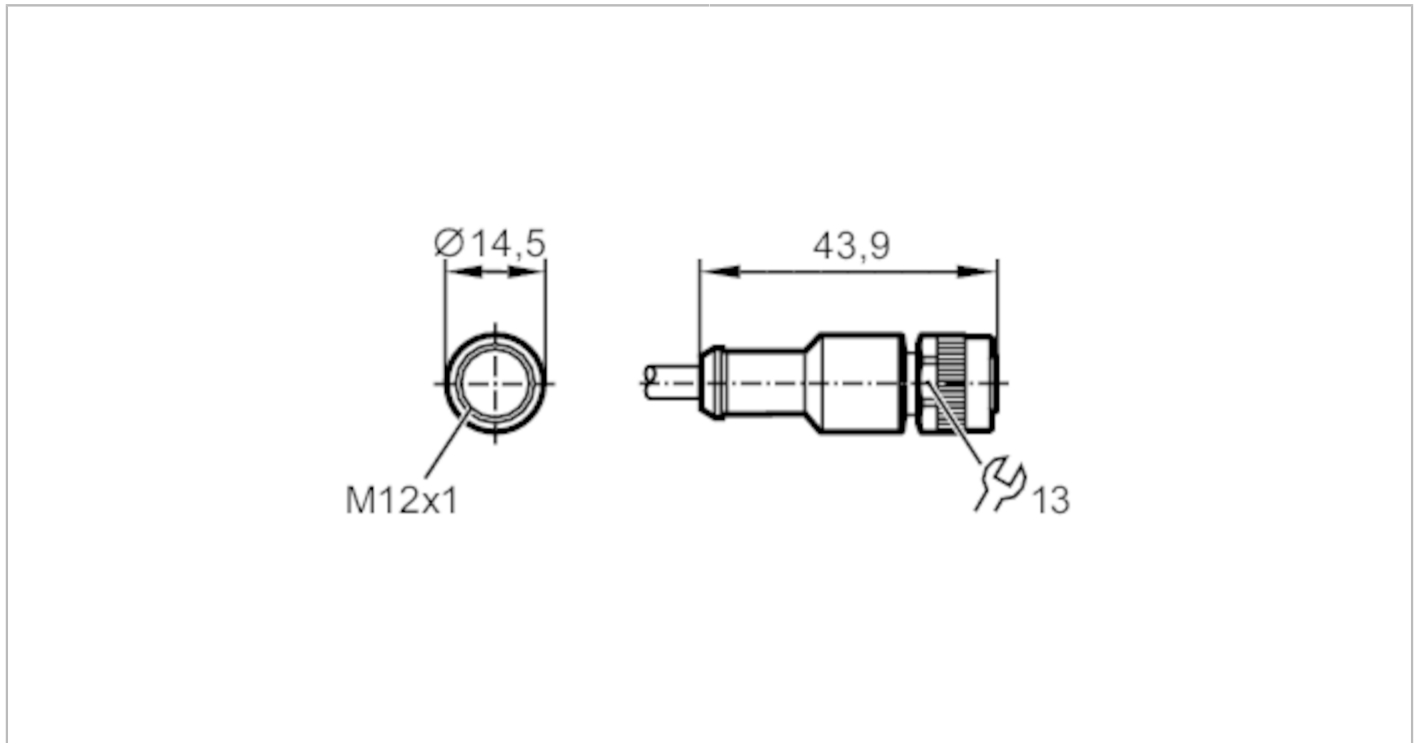

Connecting cable with socket

ADOGH120ZDS0005H12



Application		
Special feature	Free from silicone; Halogen-free; Gold-plated contacts; Drag chain suitability	
Free from silicone	yes	
Electrical data		
Operating voltage [V]	< 30 AC/DC	
Protection class	II	
Max. current load total [A]	1.5	
Operating conditions		
Ambient temperature [°C]	-25...90	
Protection	IP 67	
Mechanical data		
Weight [g]	326	
Materials	PUR	
Moulded-body material	PUR	
Material nut	diecast zinc	
Drag chain suitability	yes	
Drag chain suitability	bending radius for flexible use	min. 10 x cable diameter
	travel speed	max. 3.3 m/s for a horizontal travel length of 5 m and max. acceleration of 5 m/s ²
	bending cycles	> 5 Mio.
Remarks		
Pack quantity	1 pcs.	

E12502



Connecting cable with socket

ADOGH120ZDS0005H12

Electrical connection

Cable: 5 m, PUR, Halogen-free, black, \varnothing 6.6 mm; 12 x 0.25 mm²

Electrical connection - socket

Connector: 1 x M12, straight; Moulded body: PUR; Locking: diecast zinc; Contacts: gold-plated; Tightening torque: 0.7...0.9 Nm

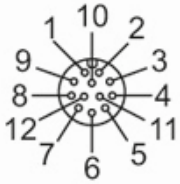

E12502



Connecting cable with socket

ADOGH120ZDS0005H12

Connection

1	BN
2	BU
3	WH
4	GN
5	PK
6	YE
7	BK
8	GY
9	RD
10	VT
11	GY/PK
12	RD/BU

Core colours :

BK =	black
BN =	brown
BU =	blue
GN =	green
GY =	grey
GY/PK =	grey/pink
PK =	pink
RD =	red
VT =	lilac
WH =	white
YE =	yellow
RD/BU =	red/blue