

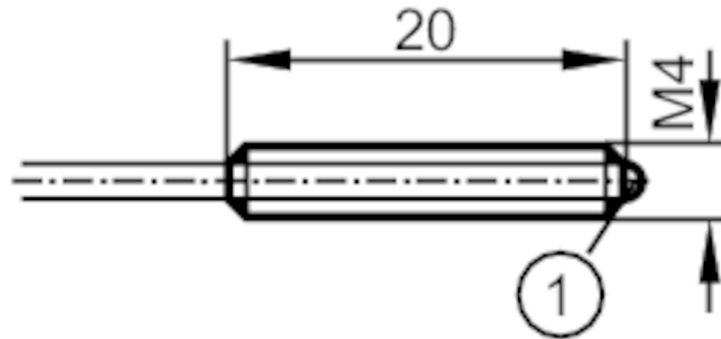

Fibre optic through-beam sensor

FE-11-EPA-M4/F1x1/2M



1 glass lens

Application

Function principle Through-beam sensor

Detection zone

Range with fibre optic amplifier type OB50; OBF; OO50

OB50

Range of fibre optics [mm] 400

OBF

Range of fibre optics [mm] 900

OO50

Range of fibre optics [mm] 1600

Operating conditions

Ambient temperature [°C] -40...70

E20753



Fibre optic through-beam sensor

FE-11-EPA-M4/F1x1/2M

Mechanical data	
Weight [g]	47.5
Version of sensing head	straight
Sensing head thread	M4
Total length [mm]	2000
Min. bending radius [mm]	30
Fibre arrangement	●
Core diameter [mm]	1
Fibre material	PMMA
Fibre head material	aluminium
Fibre sheath material	PE
Accessories	
Items supplied	hexagon nuts: 4 x M4 tooth lock washers: 4
Accessories (optional)	Cutter for fibre optics:, E20600
Remarks	
Pack quantity	1 pcs.