

# E21126

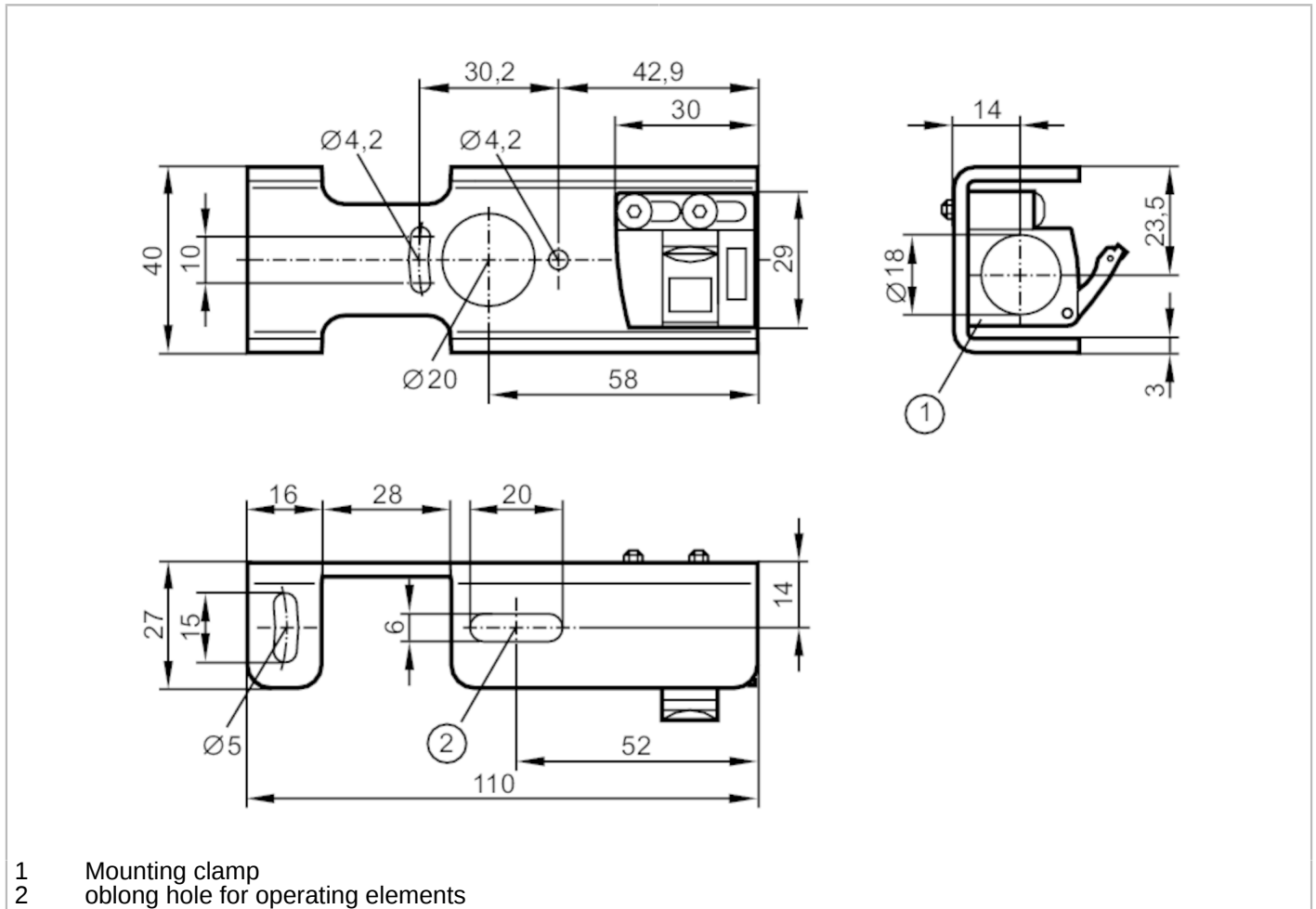

## Protective cover

OG PROTECTIVE BRACKET ROD



Application	
Design	clamp mounting, with end stop
Mechanical data	
Weight	[g] 192.5
Dimensions	[mm] 27 x 40 x 110
Inside diameter	[mm] 18
Materials	PC black; Angle brackets: stainless steel (1.4404 / 316L)
Remarks	
Pack quantity	1 pcs.