

E2M211

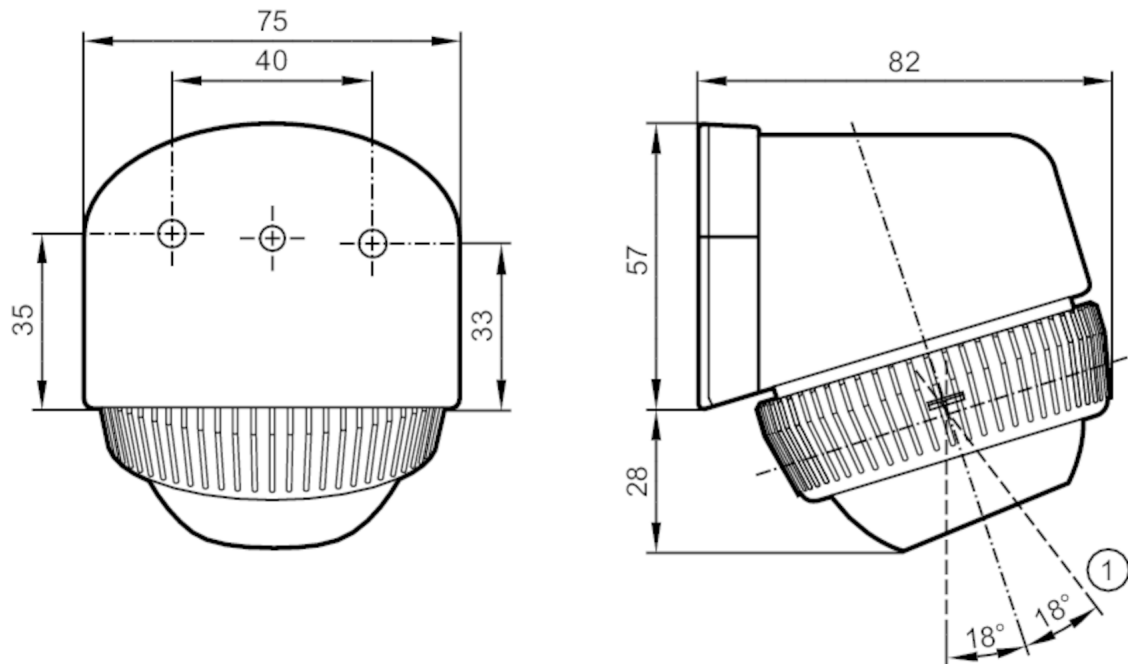

Mounting bracket for analogue cameras

DOME ADAPTER CCC



1: pivoting range

Operating conditions

Ambient temperature [°C] -40...85

Mechanical data

Weight [g] 143

Dimensions [mm] 85 x 75 x 82

Materials housing: ABS glass fibre reinforced; PC; PA

Accessories

Items supplied screws: 2 x M5
washers: 2
hexagon nuts: 2

Remarks

Pack quantity 1 pcs.