

E30149

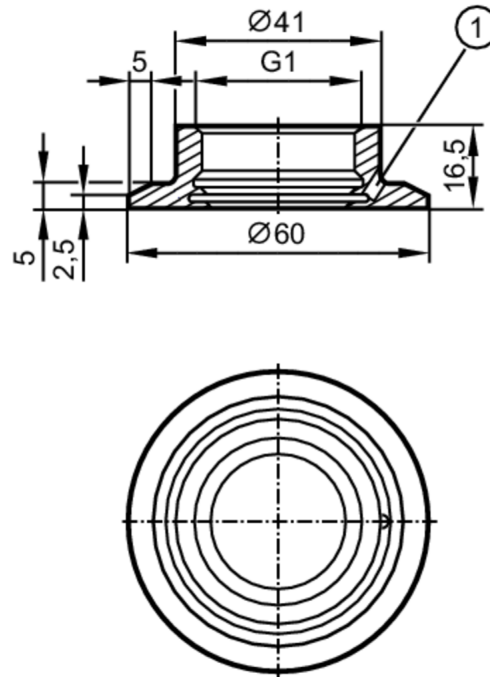

Welding adapter for process sensors

WELDING ADAPT D60/G1 LEAK PORT



1 Leakage port



EHEDG Certified

Application	
Design	with leakage port
Pressure rating [bar]	25
Note on pressure rating	for the connection sensor - adapter
Tests / approvals	
Pressure Equipment Directive	A possible classification to PED depends on the application and has to be carried out by the user / operator.
Safety instructions	The compatibility between medium and product material has to be checked in all applications.
Mechanical data	
Weight [g]	158
Materials (wetted parts)	stainless steel (1.4435 / 316L) ; surface characteristics : Ra<0,4 / Rz 4
Sensor connection	G 1 Aseptoflex Vario
Process connection	welding adapter Ø 60 mm
Sealing	Gasket
Accessories	
Items supplied	O-ring: 1 x 24 x 2, EPDM, FDA compliant, E30054
Accessories (optional)	O-ring: 1 x 24 x 2, FKM, FDA compliant, E30123
Remarks	
Pack quantity	1 pcs.