

E30151

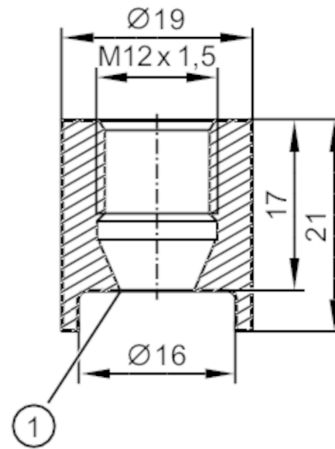

Welding adapter for process sensors

ADAPT M12-WELDING ACCESSORY



1 sealing edge

EC 1935/2004 

Application		
Medium temperature	[°C]	< 250
Pressure rating	[bar]	50
Mechanical data		
Weight	[g]	32.9
Materials		stainless steel (1.4404 / 316L)
Tightening torque	[Nm]	5...20
Sensor connection		M12 x 1,5 sealing cone
Process connection		welding adapter Ø 19 mm
Remarks		
Pack quantity		1 pcs.