

E3M161

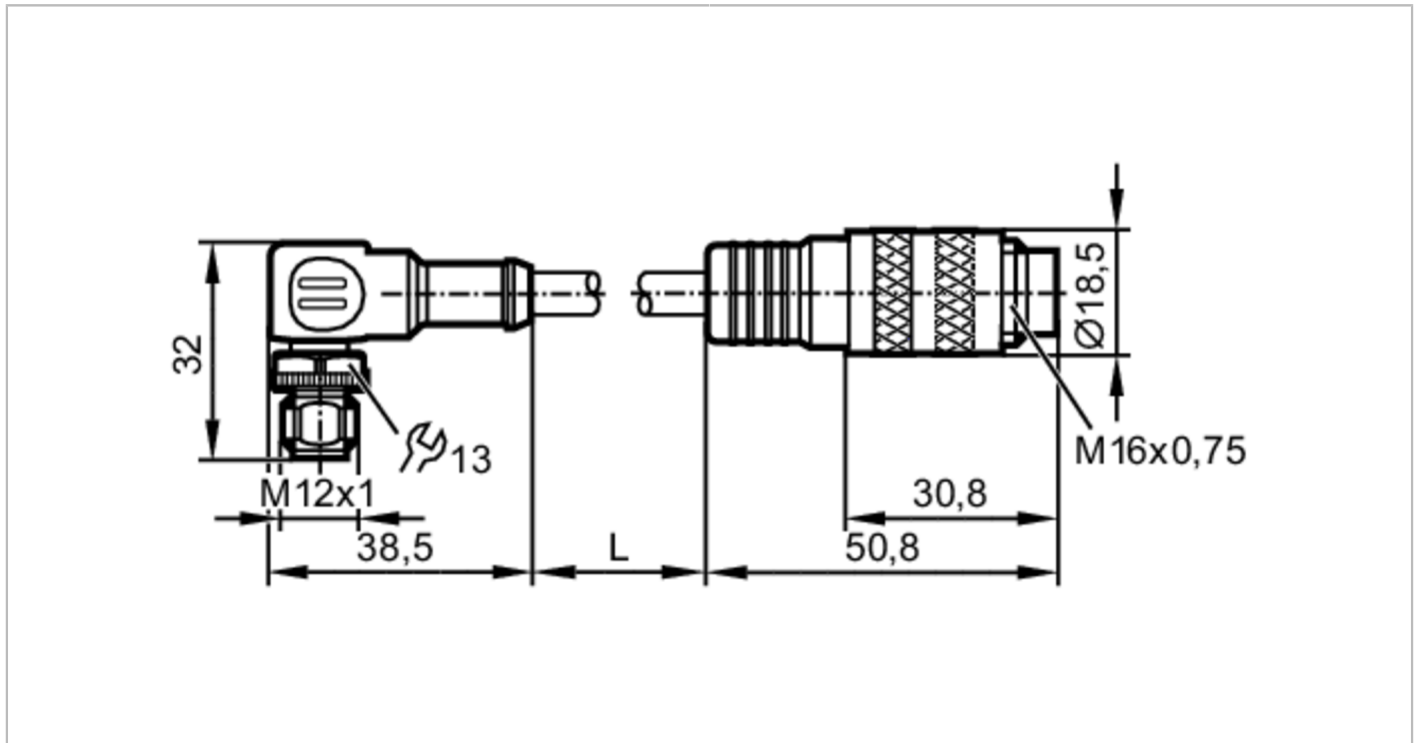

Connection cable

VIDEO ADAPTER CABLE M12 M16



Application	
Special feature	Screened cable; Drag chain suitability
Design	for 3D Smart sensor mobile with analogue video output PAL
Operating conditions	
Ambient temperature	[°C] -40...80
Ambient temperature (moving)	[°C] -10...70
Protection	IP 67; IP 69K
Mechanical data	
Weight	[g] 93.8
Materials	PUR black; sealing ring: FKM; contact pins: CuSn6 nickel-plated and tin-plated
Moulded-body material	PUR / PUR
Material nut	stainless steel (1.4305 / 303) / stainless steel (1.4305 / 303)
Drag chain suitability	yes
Drag chain suitability	bending radius for fixed installation ≥ 60 mm
Remarks	
Pack quantity	1 pcs.
Electrical connection - plug	

Connector: 1 x M12, angled; Moulded body: PUR; Locking: stainless steel (1.4305 / 303); Shielded connection cable: screen connected

E3M161



Connection cable

VIDEO ADAPTER CABLE M12 M16

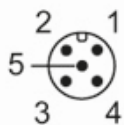

Electrical connection

Cable: 1 m, PUR, black, Ø 6 mm, shielded; 2 x 0.25 mm²

Connection

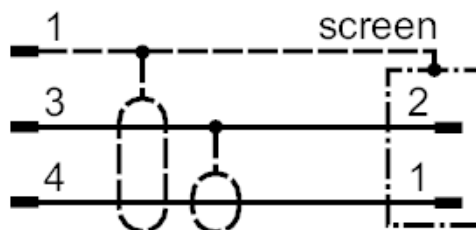

Electrical connection - plug

Connector: 1 x M16, straight; Moulded body: PUR; Locking: stainless steel (1.4305 / 303); Shielded connection cable: screen connected

