

E43230

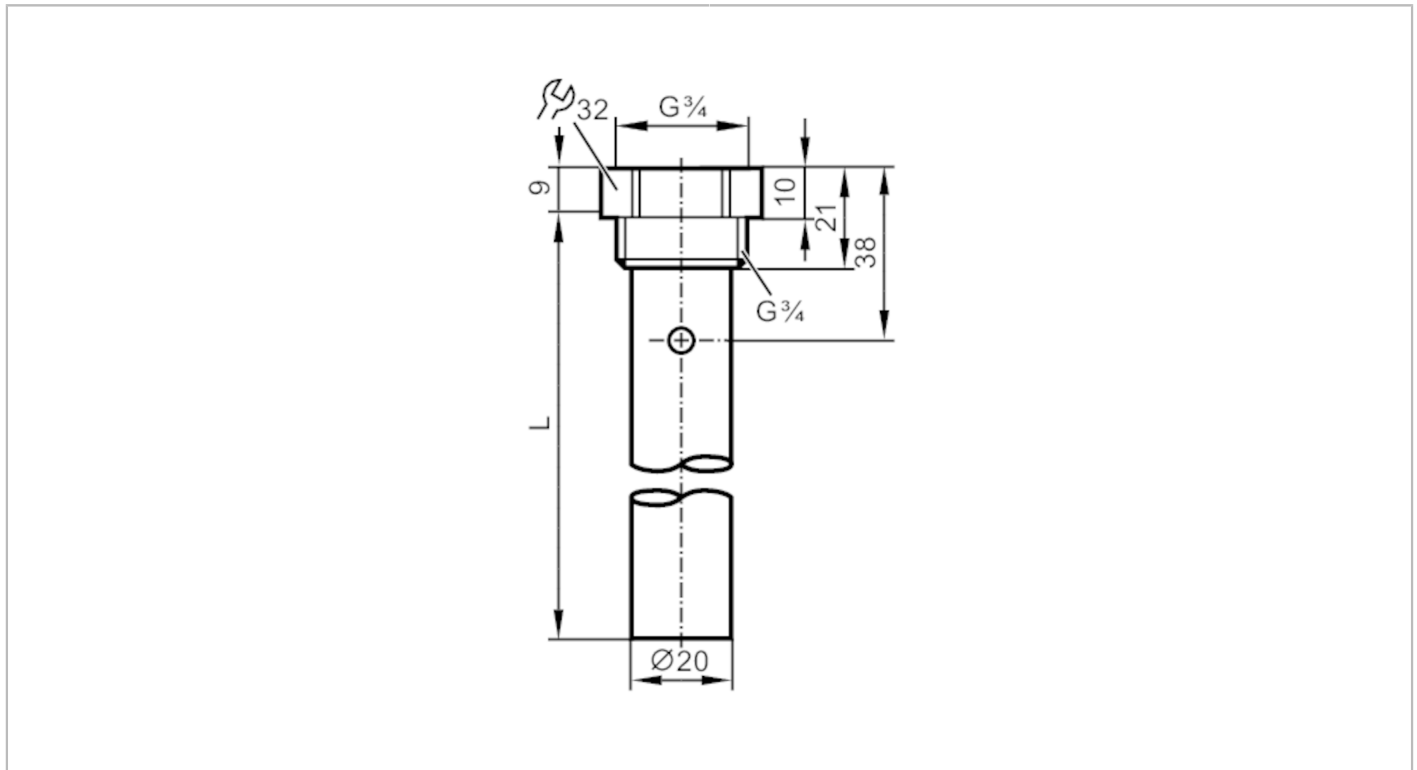

Coaxial pipe for level sensors

LR COAX TUBE G3/4 L150



CRN

Application	
Design	for level sensors LR
Medium temperature [°C]	-20...200
Pressure rating [bar]	16
Vacuum resistance [mbar]	-1000
MAWP (for applications according to CRN) [bar]	16
Mechanical data	
Weight [g]	135
Materials	Coaxial pipe: stainless steel (1.4301 / 304); Sealing: NBR reinforced fibre; Centring piece: PPS reinforced fibre; Fixing strap: stainless steel (1.4310 / 301)
Sensor connection	G 3/4
Process connection	G 3/4
Length [mm]	150
Accessories	
Items supplied	sealings: 1
Remarks	
Pack quantity	1 pcs.